

AD-A189 523

ACCESS TO MICROGRAVITY: A TECHNICAL DESCRIPTION OF THE  
NAE (NATIONAL AERO. (U) NATIONAL AERONAUTICAL  
ESTABLISHMENT OTTAWA (ONTARIO) J F RITKEN OCT 87

1/1

UNCLASSIFIED

NAE-AN-47 NRC-28342

F/G 14/2

NL



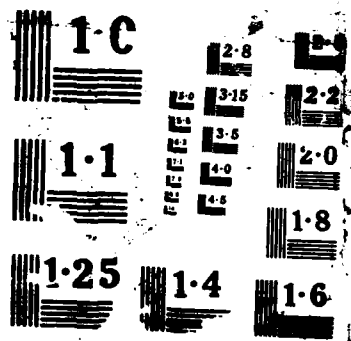

Canada (4)

UNCLASSIFIED  
UNCLASSIFIED

AD-A189 523

# ACCESS TO MICROGRAVITY: A TECHNICAL DESCRIPTION OF THE NAE T-38 MICROGRAVITY FACILITY

DTIC  
ELECTE  
DEC 28 1987  
S E D

by

**J. F. Aitken**

**National Aeronautical Establishment**

**DISTRIBUTION STATEMENT A**  
Approved for public release  
Distribution Unlimited

OTTAWA  
OCTOBER 1987

AERONAUTICAL NOTE  
NAE-AN-47  
NRC NO. 28342



National Research  
Council Canada

Conseil national  
de recherches Canada

**NATIONAL AERONAUTICAL ESTABLISHMENT  
SCIENTIFIC AND TECHNICAL PUBLICATIONS**

**AERONAUTICAL REPORTS:**

**Aeronautical Reports (LR):** Scientific and technical information pertaining to aeronautics considered important, complete, and a lasting contribution to existing knowledge.

**Mechanical Engineering Reports (MS):** Scientific and technical information pertaining to investigations outside aeronautics considered important, complete, and a lasting contribution to existing knowledge.

**AERONAUTICAL NOTES (AN):** Information less broad in scope but nevertheless of importance as a contribution to existing knowledge.

**LABORATORY TECHNICAL REPORTS (LTR):** Information receiving limited distribution because of preliminary data, security classification, proprietary, or other reasons.

Details on the availability of these publications may be obtained from:

Publications Section,  
National Research Council Canada,  
National Aeronautical Establishment,  
Bldg. M-16, Room 204,  
Montreal Road,  
Ottawa, Ontario  
K1A 0R6

**ÉTABLISSEMENT AÉRONAUTIQUE NATIONAL  
PUBLICATIONS SCIENTIFIQUES ET TECHNIQUES**

**RAPPORTS D'AÉRONAUTIQUE**

**Rapports d'aéronautique (LR):** Informations scientifiques et techniques touchant l'aéronautique jugées importantes, complètes et durables en termes de contribution aux connaissances actuelles.

**Rapports de génie mécanique (MS):** Informations scientifiques et techniques sur la recherche externe à l'aéronautique jugées importantes, complètes et durables en termes de contribution aux connaissances actuelles.

**CAHIERS D'AÉRONAUTIQUE (AN):** Informations de moindre portée mais importantes en termes d'accroissement des connaissances.

**RAPPORTS TECHNIQUES DE LABORATOIRE (LTR):** Informations peu disséminées pour des raisons d'usage secret, de droit de propriété ou autres ou parce qu'elles constituent des données préliminaires.

Les publications ci-dessus peuvent être obtenues à l'adresse suivante:

Section des publications  
Conseil national de recherches Canada  
Établissement aéronautique national  
Im. M-16, pièce 204  
Chemin de Montréal  
Ottawa (Ontario)  
K1A 0R6

UNLIMITED  
UNCLASSIFIED

4

**ACCESS TO MICROGRAVITY:  
A TECHNICAL DESCRIPTION OF  
THE NAE T-33 MICROGRAVITY FACILITY**

**ACCÈS À LA MICROGRAVITÉ:  
DESCRIPTION TECHNIQUE DES INSTALLATIONS  
POUR LES EXPÉRIENCES EN MICROGRAVITÉ  
À BORD DU T-33 DE L'ÉAN**

by/par

**J.F. Aitken**

**National Aeronautical Establishment**

**SDTIC  
ELECTE  
DEC 28 1987  
E**

**OTTAWA  
OCTOBER 1987**

**AERONAUTICAL NOTE  
NAE-AN-47  
NRC NO. 28342**

**87 12 14 102**

**S.R.M. Sinclair, Head/Chef  
Flight Research Laboratory/  
Laboratoire de recherche en vol**

**G.F. Marsters  
Director/Directeur**

## ABSTRACT

The National Aeronautical Establishment operates a T-33 aircraft as a facility for short duration microgravity experiments. Details covering sensors available, experiment electrical and mechanical requirements, package size constraints, power available, and requirements for interfacing experiments with the aircraft instrumentation system are provided for the microgravity experimenter.

## RÉSUMÉ

L'Établissement aéronautique national utilise un appareil T-33 comme installation pour effectuer des expériences de courte durée en microgravité. Des détails sur les capteurs disponibles, les exigences au point de vue électrique et mécanique pour les expériences, la puissance disponible et les exigences concernant l'interface entre les expériences et l'instrumentation de l'aéronef sont fournies aux expérimentateurs.



|                    |                                     |
|--------------------|-------------------------------------|
| Accession For      |                                     |
| NTIS GRA&I         | <input checked="" type="checkbox"/> |
| DTIC TAB           | <input type="checkbox"/>            |
| Unannounced        | <input type="checkbox"/>            |
| Justification      |                                     |
| By _____           |                                     |
| Distribution/      |                                     |
| Availability Codes |                                     |
| Dist               | Avail and/or<br>Special             |
| A-1                |                                     |

## TABLE OF CONTENTS

|  | Page  |
|--|-------|
| SUMMARY . . . . .  | (iii) |
| 1.0 INTRODUCTION . . . . .                                   | 1     |
| 2.0 TEST CONDITIONS . . . . .                                | 1     |
| 3.0 TEST AIRCRAFT AND EQUIPMENT - GENERAL . .                | 1     |
| 3.1 Rack and Mounting Plates for<br>Experiments . . . . .    | 4     |
| 3.2 Cockpit Environment . . . . .                            | 6     |
| 3.3 Electric Power . . . . .                                 | 6     |
| 3.4 Instrumentation System . . . . .                         | 10    |
| 4.0 MICROGRAVITY EXPERIMENT INTERFACING . . .                | 14    |
| 5.0 POST FLIGHT DOCUMENTATION . . . . .                      | 20    |
| 6.0 MECHANICAL & ELECTRICAL DESIGN<br>REQUIREMENTS . . . . . | 20    |
| 7.0 TOXIC MATERIALS . . . . .                                | 20    |
| 8.0 SAFETY REVIEW . . . . .                                  | 21    |
| 9.0 CONCLUDING REMARKS . . . . .                             | 22    |

## TABLES

| Table |   | Page |
|-------|---|------|
| 1     | T-33 Dimensions & Performance . . . . . | 4    |
| 2     | Power Available . . . . .               | 10   |
| 3     | C-FSKH Sensor List . . . . .            | 12   |
| 4     | Accelerometer Characteristics . . . . . | 14   |

**TABLE OF CONTENTS (cont'd)**

| <b>Figure</b> |  | <b>Page</b> |
|---------------|--|-------------|
| 1             | Zero 'G' Flight Profile . . . . .                            | 2           |
| 2             | The NAE T-33 C-FSKH . . . . .                                | 3           |
| 3             | Rear Cockpit Experiment Rack . . . . .                       | 5           |
| 4             | Test Equipment Mounting Plate . . . . .                      | 7           |
| 5             | Cabin Pressure vs Aircraft Altitude. . . . .                 | 8           |
| 6             | Micro-G Power Source Map . . . . .                           | 9           |
| 7             | C-FSKH Instrumentation System. . . . .                       | 11          |
| 8             | Analog Signal Conditioning Circuit . . . . .                 | 13          |
| 9             | Micro-G Rack/Instrumentation System<br>Interconnect. . . . . | 15          |
| 10            | Micro-G Control Relays . . . . .                             | 16          |
| 11            | Micro-G User Experiment Electrical<br>Connection. . . . .    | 18          |
| 12            | NAE D-Bus Interface Prototyping<br>Board . . . . .           | 19          |

**APPENDICES**

| <b>Appendix</b> |  | <b>Page</b> |
|-----------------|--|-------------|
| I               | FRL Laboratory Memorandum FR-63(c) . . . . . | 23          |
| II              | FRL Laboratory Memorandum FR-63(e) . . . . . | 28          |

## 1.0 INTRODUCTION

The Flight Research Laboratory (FRL) of the National Aeronautical Establishment (NAE) operates a T-33 aircraft which can be used as a microgravity facility. The aircraft is based at Ottawa, Ontario and will be made available to parties interested in performing short duration experiments under near zero gravity conditions. This report gives a description of the aircraft facilities available to the user as well as requirements with which the user will have to comply.

## 2.0 TEST CONDITIONS

Short periods of near zero gravity conditions can be achieved in an aircraft by approximating a parabolic arc flight path. Duration of the microgravity condition depends upon aircraft speed and pitch angle at the beginning of the arc. With an entry speed of 400 to 420 knots and an initial pitch angle of approximately  $45^\circ$ , a period of 20 to 25 seconds of near zero gravity conditions is possible (Figure 1). Turbulence, aircraft pitch rate, vibrations, control system limitations and limits to the pilot's capabilities in flying a precise parabolic arc all combine to detract from the ideal zero gravity condition, however load factors of  $\pm 0.02$  'g' or less, all axes, should be achievable in the NAE T-33. Depending upon user requirements, the parabolic arc manoeuvre can be repeated up to 12 times per flight, each flight lasting about an hour and 15 minutes.

## 3.0 TEST AIRCRAFT AND EQUIPMENT - GENERAL

The test aircraft is the NAE T-33 C-FSKH (Figure 2). Aircraft dimensions and some performance capabilities are

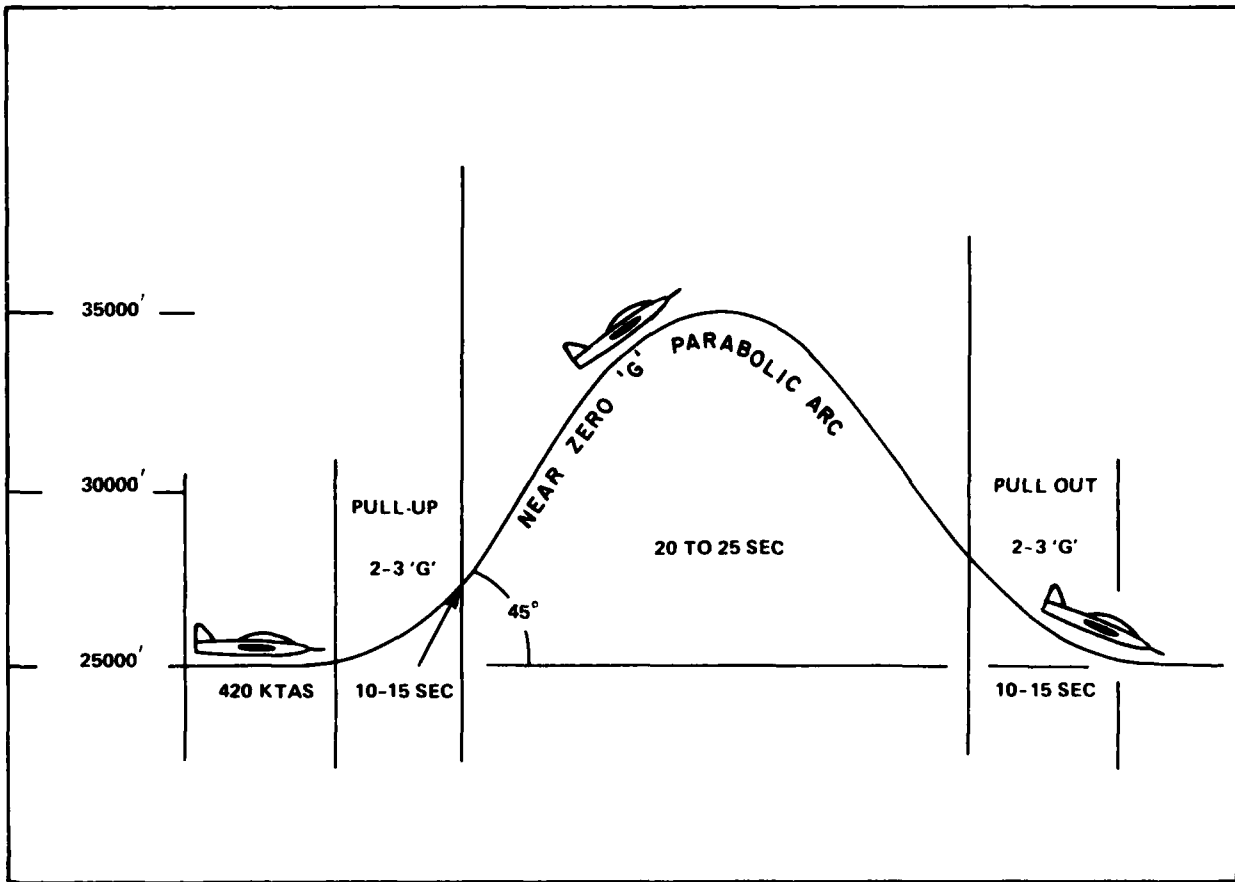

FIG. 1: ZERO "G" FLIGHT PROFILE



FIG. 2: THE NAE T33, C-FSKH

given in Table 1. The aircraft is used for various airborne research applications and is equipped with an instrumentation and recording system. Normally a two seat aircraft, for microgravity flight, the aircraft is converted to a single seat configuration. The rear seat is removed and replaced by a variable height rack (Figure 3) designed to hold standard sized experiment mounting plates.

**Table 1**  
**T-33 Dimensions and Performance**

**Dimensions**

|             |            |
|-------------|------------|
| Wingspan    | 42 ft 5 in |
| Length      | 27 ft 9 in |
| Height      | 11 ft 8 in |
| Weight max. | 16,800 lb  |

**Performance**

|                             |                         |
|-----------------------------|-------------------------|
| Cruising Speed              | .72 MN/415 KTAS @ 35000 |
| Max Allowable Speed         | .8 MN/505 KIAS          |
| Vertical Load Factor Limits | + 7.33 G - 3.0 G        |

**3.1 Rack and Mounting Plates for Experiments**

The rear cockpit experiment rack can accommodate up to 4 experiment plates, depending upon equipment height. Mounted on the bottom layer of the rack are relays to control user experiments and a precision 3-axis accelerometer package for accurate measurement of the microgravity environment. Vibration mounts are used to isolate the entire rack from the aircraft. The rack system can support experimental packages weighing up to a total of 200 lb. Total height of the equipment in the experiment rack is limited to 33 inches.

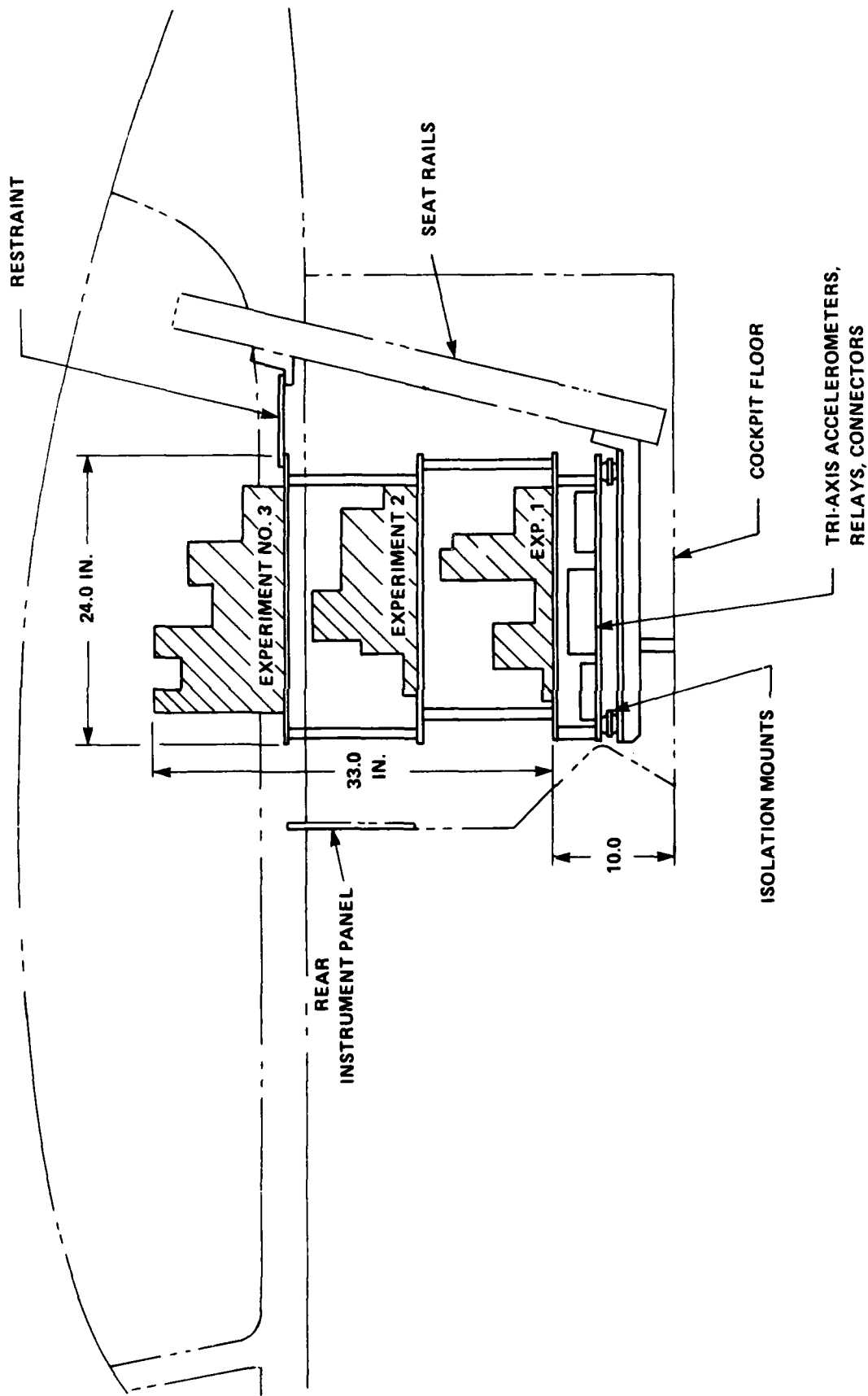

FIG. 3: REAR COCKPIT EXPERIMENT RACK, SHOWING 3-EXPERIMENT OPTION

User experiments are mounted in layers on NAE supplied 18 inch by 24 inch plates (Figure 4). The area at the corners and along the edges of the plates is reserved for securing the plates in the rack. Equipment should not extend beyond the area shown.

### 3.2 Cockpit Environment

Experimental packages are located in the cockpit and are thus subject to cockpit temperature and pressure variations. Temperature is normally regulated in the 15 to 25°C range, however "greenhouse" effect and winter temperatures can increase this range significantly. Variation of cockpit pressure with aircraft altitude is shown in Figure 5. Aircraft altitude ranges planned for the microgravity parabolas are 6000 to 16000 feet and 25000 to 35000 feet.

### 3.3 Electrical Power

All aircraft electrical power originates from a 28 volt DC generator. This power is routed directly and through inverters and regulators (Figure 6) to provide the microgravity experimenter with several power options. Power available is given in Table 2.

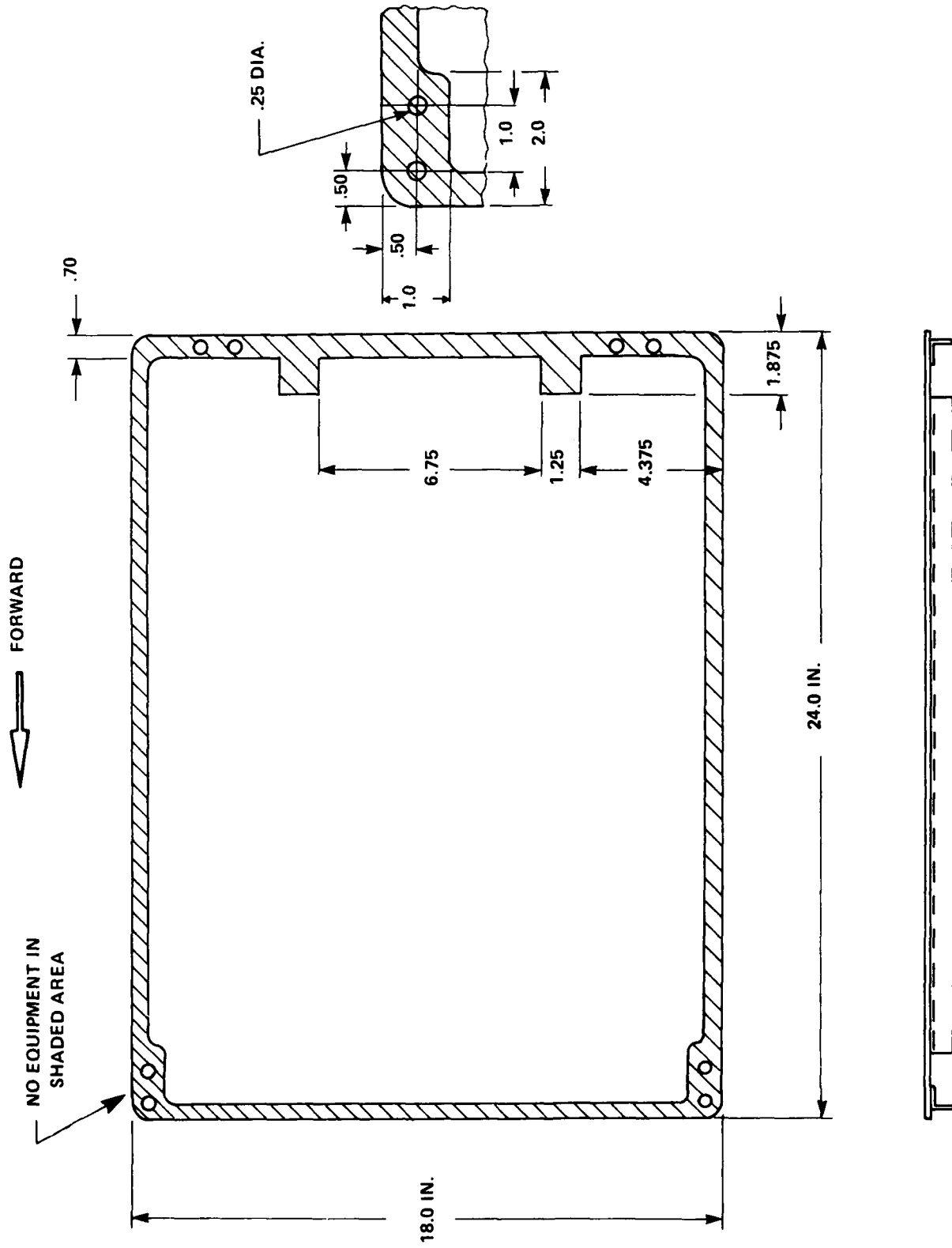

FIG. 4: TEST EQUIPMENT MOUNTING PLATE

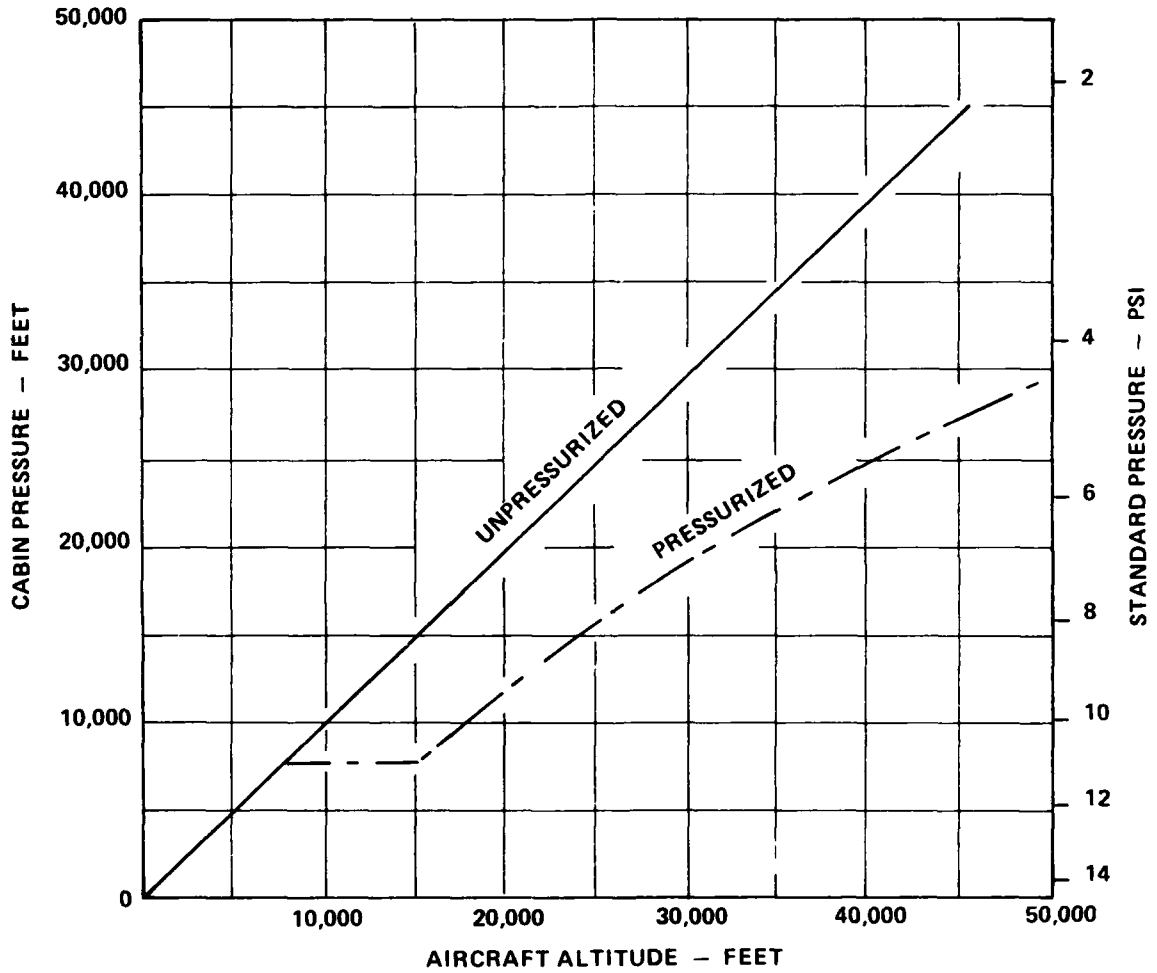

FIG. 5: CABIN PRESSURE VS AIRCRAFT ALTITUDE

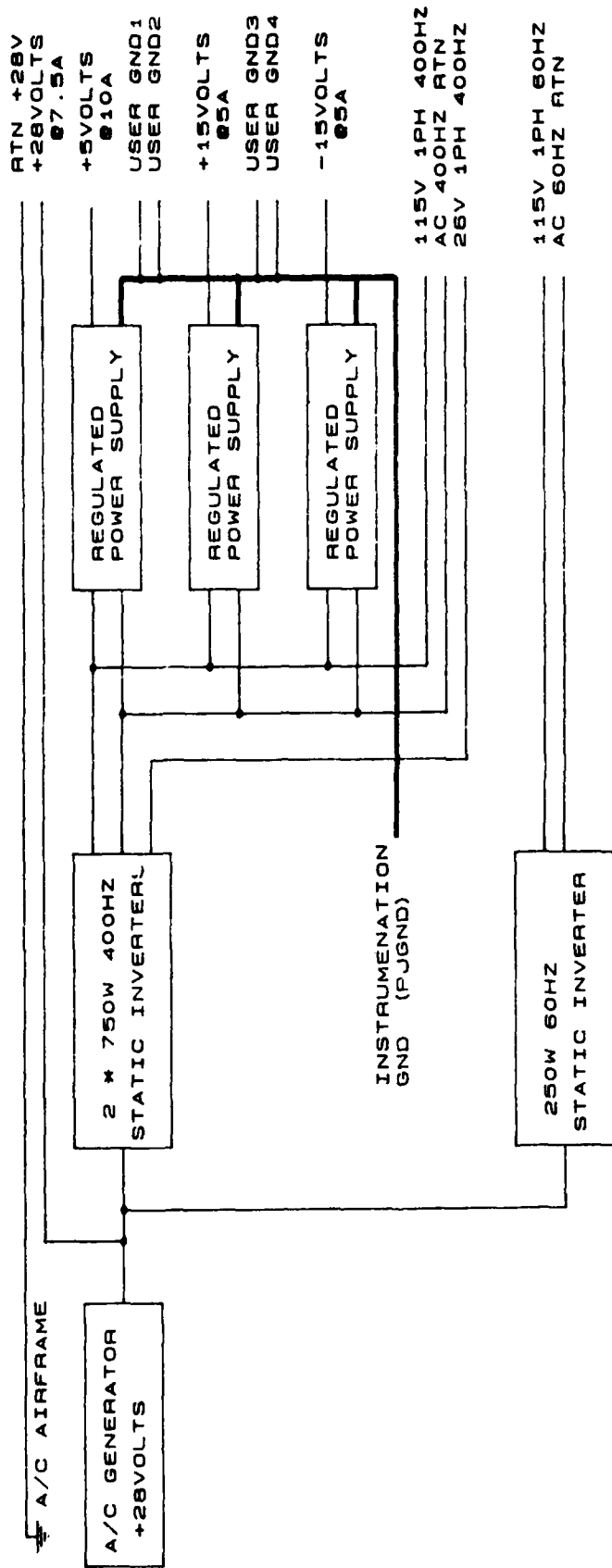

FIG. 6: MICRO-G POWER SOURCE MAP

**Table 2**  
**Power Available**

| <b>Source</b>                 | <b>Voltage</b>   | <b>Frequency</b>             | <b>Power</b>     |
|-------------------------------|------------------|------------------------------|------------------|
| aircraft generator            | 28               | DC                           | 7.5 amps*        |
| 400 Hz single phase inverters | 115<br>26        | 400 Hz}<br>400 Hz}           | 900 va           |
| regulated DC power supplies   | +5<br><u>+15</u> | regulated DC<br>regulated DC | 5 amps<br>5 amps |
| 60 Hz single phase inverter   | 115              | 60 Hz                        | 250 va           |

\* an additional 45 amps of 28 volt DC is also possible

### **3.4 Instrumentation System**

The aircraft instrumentation system (Figure 7) is based upon a Digital Equipment PDP 11/73 computer, processing and recording 16 bit data words onto a 1/4 inch streaming tape system. Although the system is primarily intended to be operated from the rear cockpit, for the purposes of microgravity experiments, it can be controlled from the front. Front cockpit space constraints limit control and display capability to a computer initialize switch, data record switch, three event level switches, and an LCD 2 line by 16 character alpha numeric display. The display can be used to provide the pilot with limited test parameter information. Pilot interaction with test packages is accomplished through the computer via three event switches. Packages with complex control requirements can be accommodated via software control.

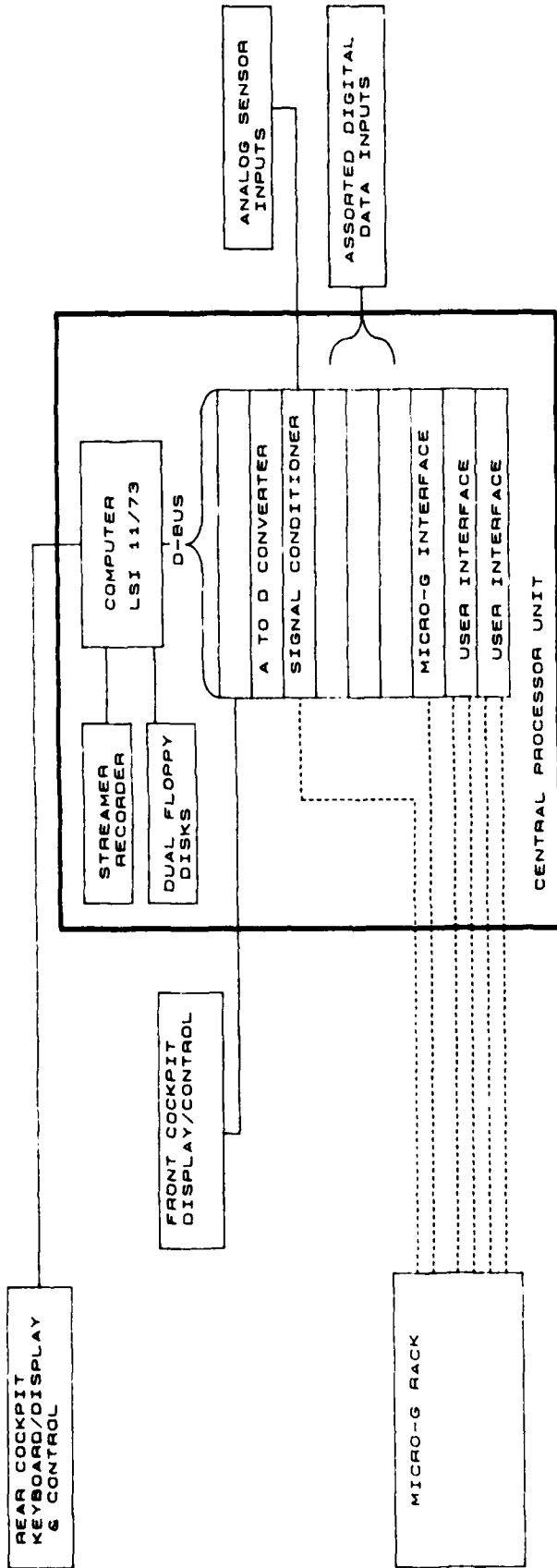

FIG. 7: C-FSKH INSTRUMENTATION SYSTEM

In its standard configuration the instrumentation system can provide a 3 hour (60 Mbyte) digital recording of up to 32 variables at 32 Hz. Analog signals are conditioned (Figure 8) and resolved to 12 bits before recording.

Table 3 lists onboard sensors available for recording. A suggested recording configuration list for microgravity flights would include the first 16 variables plus several user specified status and control variables.

**TABLE 3**  
**C-PSKH Sensor List**

|                     |                           |
|---------------------|---------------------------|
| 1. dynamic pressure | 17. radio altitude        |
| 2. static pressure  | 18. Inertial Vx           |
| 3. heading          | 19. Inertial Vy           |
| 4. pitch angle      | 20. Inertial Vz           |
| 5. roll angle       | 21. GNS latitude          |
| 6. pitch rate       | 22. GNS longitude         |
| 7. roll rate        | 23. throttle position     |
| 8. yaw rate         | 24. engine RPM            |
| 9. airframe ax      | 25. elevator position     |
| 10. airframe ay     | 26. aileron position      |
| 11. airframe az     | 27. rudder position       |
| 12. micro 'g' ax    | 28. angle of attack       |
| 13. micro 'g' ay    | 29. angle of sideslip     |
| 14. micro 'g' az    | 30. localizer deviation   |
| 15. time            | 31. glide slope deviation |
| 16. event           | 32. total temperature     |

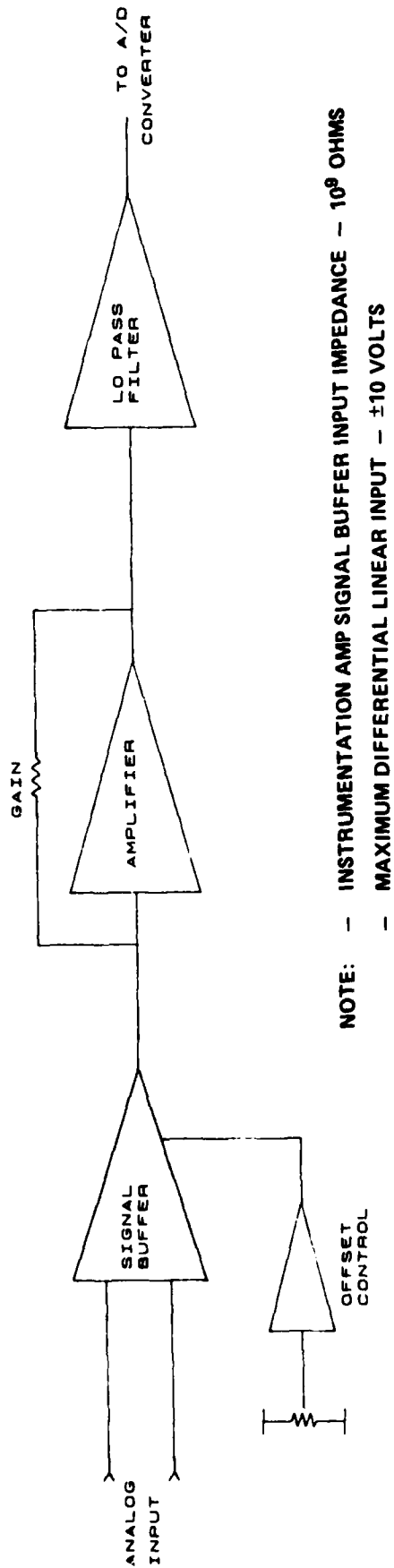

FIG. 8: ANALOG SIGNAL CONDITIONING CIRCUIT

Airframe and microgravity (experiment rack) accelerometers, sensors numbered 9 to 14 in Table 3, have the ranges, accuracies and resolutions shown in Table 4.

**Table 4**  
**Accelerometer Characteristics**

|              | <b>Recorded</b> |                 |                   |
|--------------|-----------------|-----------------|-------------------|
|              | <b>Range</b>    | <b>Accuracy</b> | <b>Resolution</b> |
|              | (g)             | (g)             | (g)               |
| airframe ax  | <u>+2</u>       | <u>+.002</u>    | .001              |
| airframe ay  | <u>+2</u>       | <u>+.002</u>    | .001              |
| airframe az  | <u>+6</u>       | <u>+.006</u>    | .003              |
| micro 'g' ax | <u>+1</u>       | <u>+.001</u>    | .0005             |
| micro 'g' ay | <u>+1</u>       | <u>+.001</u>    | .0005             |
| micro 'g' az | <u>+1</u>       | <u>+.001</u>    | .0005             |

#### **4.0 MICROGRAVITY EXPERIMENT INTERFACING**

Electrical connections from the central processor unit (CPU) to the base of the experiment rack are made via a 60 conductor cable. As shown in Figure 9, 24 lines are assigned for control, power supply and rack acceleration signals. The remaining 36 lines are available for experiments. These lines may be used for recording experiment variables, supplying extra electrical power, or for providing extra control capability.

Up to 4 user experiments can be controlled using 4 double pole double throw 10 amp relays mounted at the base of the rack. Wired as shown in Figure 10, these relays can provide on-off control for two functions (for example: warm-up and activate) for each of 4 experiments. Relays are controlled through system software by selecting event

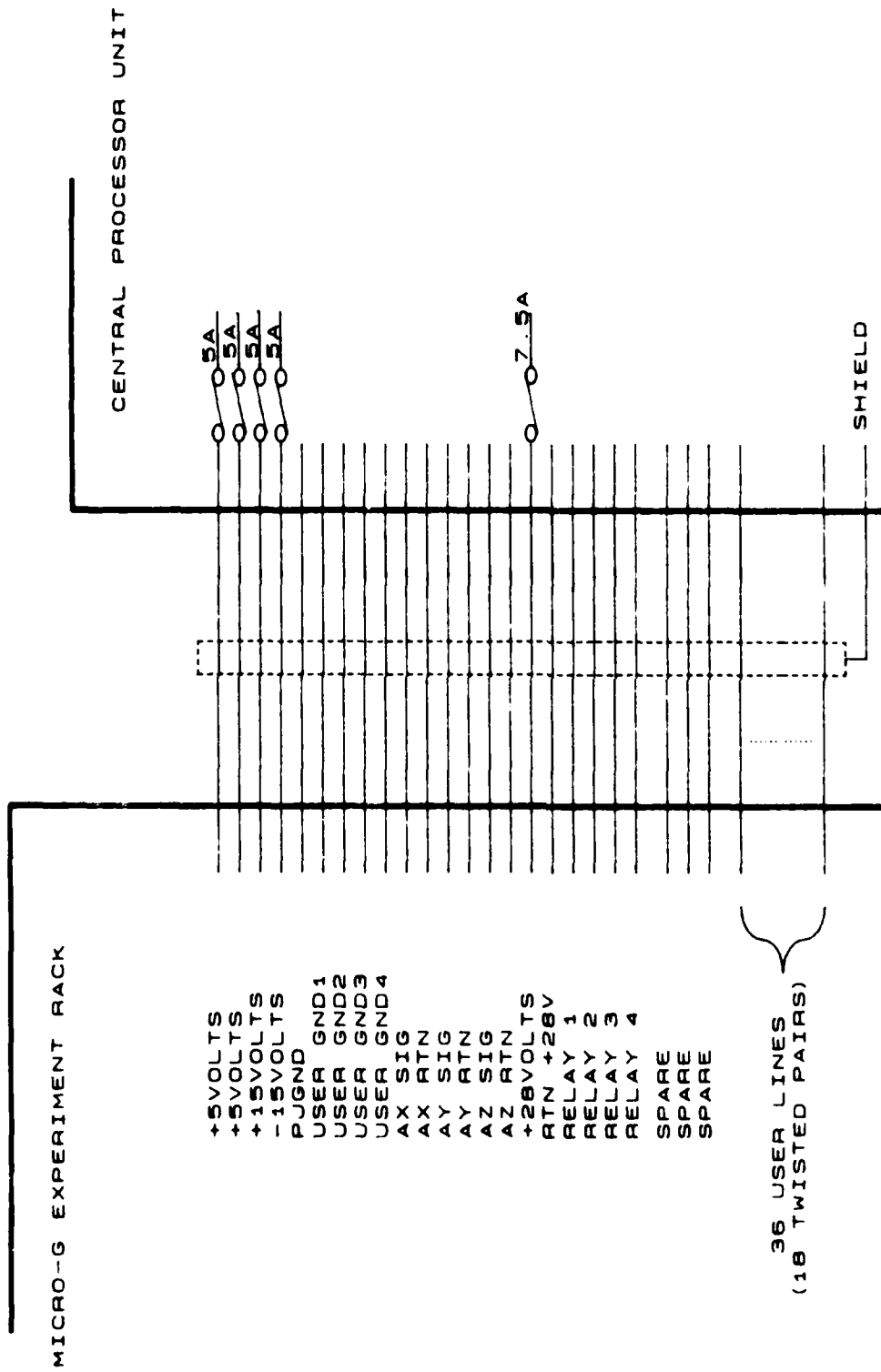

FIG. 9: MICRO-G RACK/INSTRUMENTATION SYSTEM INTERCONNECT

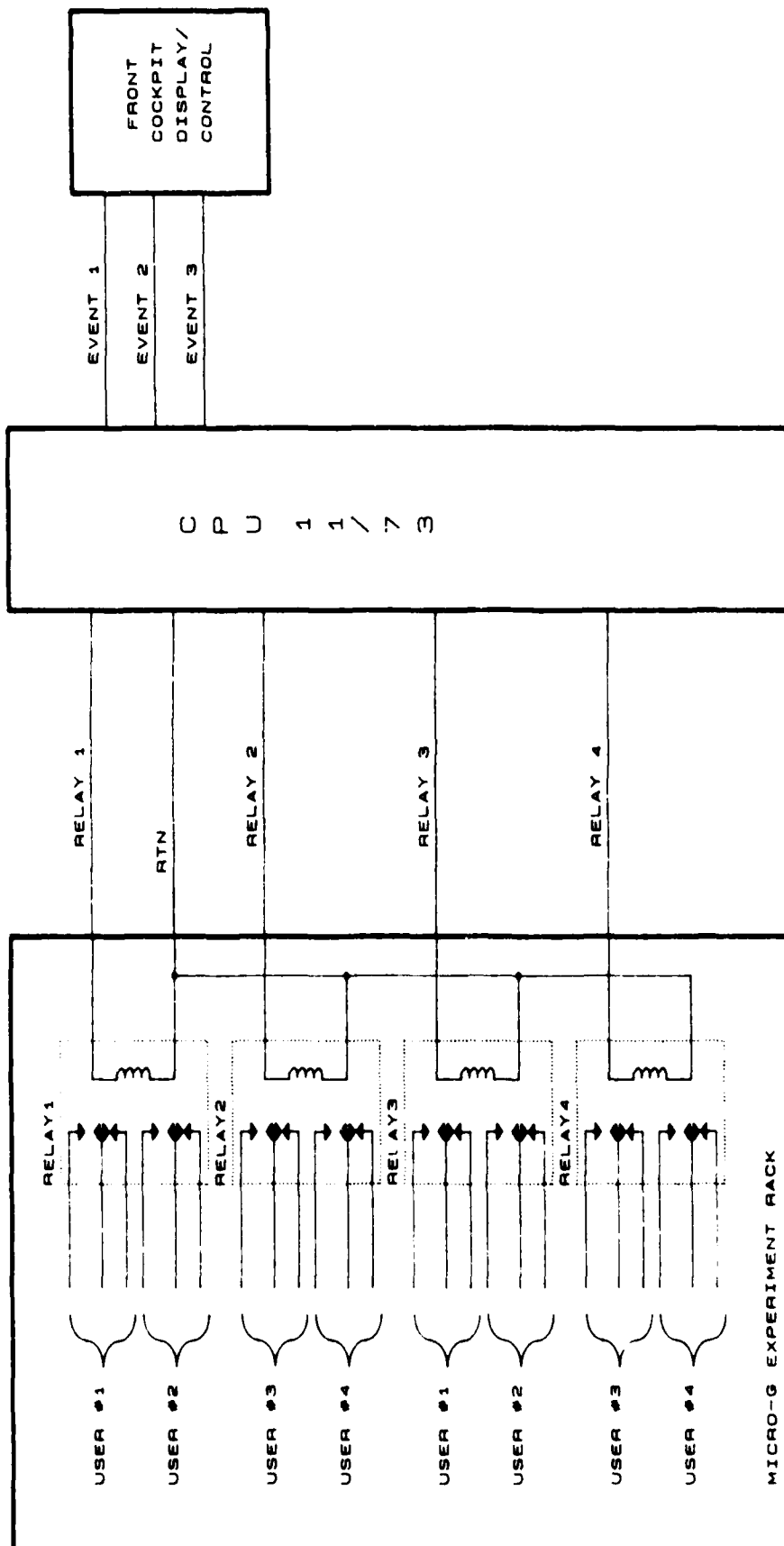

FIG. 10: MICRO-G CONTROL RELAYS

switches on the pilot's control panel. Other control options are possible. Actual control configuration will require direct discussion between the users and the FRL.

In order to simplify connecting individual experiments and to accommodate up to 4 experiments simultaneously, four 26 pin connectors are located at the base of the experiment rack. Each connector supplies one of 4 users with separate power, ground and relay lines plus 9 user option lines (Figure 11). Equipment should be wired to a terminal strip mounted on the experiment plate. A cable connecting the experiment terminal strip to the rack connector will be provided by the Flight Research Laboratory. Complex experiments may require more than one connection.

In all cases where electrical power is used, all experiment return lines (grounds) must be isolated from the rack and the airframe since the instrumentation system operates on a floating ground principle.

Serial RS 232 format communication via standard port interfaces is employed in the aircraft instrumentation system, promoting ease of communication and control with similarly formatted microgravity experiment processors. For complex experiments, user specific interfacing can be developed on NAE designed D-Bus boards (Figure 12). Features available are:

- (a) 16 bit data interfacing with host computer;
- (b) prioritized/nested interrupt;
- (c) TTL level Rubidium frequency standard of 10 MHz; and
- (d) +5V and +15V power rails.

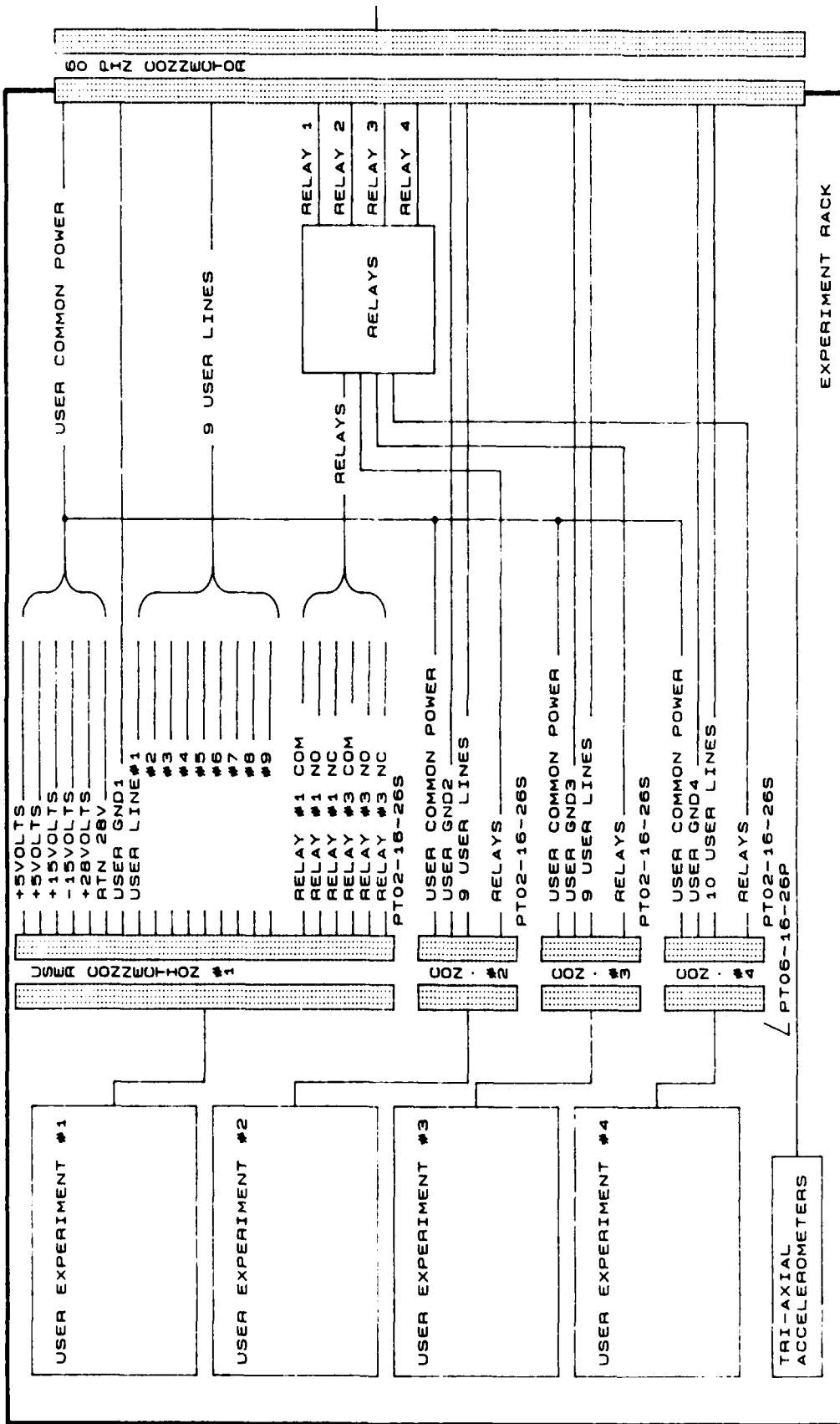

FIG. 11: MICRO-G USER EXPERIMENT ELECTRICAL CONNECTION

2 50PIN BERG CONNECTORS  
USER AREA-- INTERPOSED POWER AND  
GROUND BUSES.  
PLATED THROUGH HOLES OF  
0.035 INCH DIA. ON 0.1 INCH GRID.  
ACCEPTS DIP IC DEVICES OF VARYING  
WIDTHS.  
+5V AND +/-15V AVAILABLE.  
BOARD COMPONENT HEIGHT LIMITED  
TO LESS THAN 0.375 INCH.

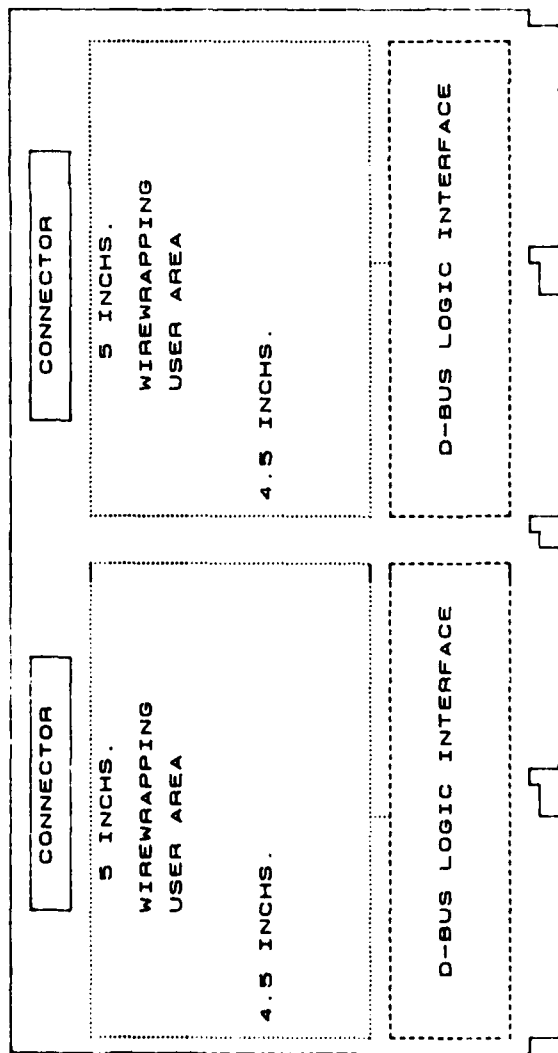

FIG. 12: NAE D-BUS INTERFACE PROTOTYPING BOARD

## **5.0 POST FLIGHT DOCUMENTATION**

The FRL will supply the user with a data package documenting the conditions encountered and recorded during the experiment. Format and medium of such documentation will be agreed upon in discussions with the FRL.

## **6.0 MECHANICAL AND ELECTRICAL DESIGN REQUIREMENTS**

In addition to requirements covered above, which should ensure compatibility with the aircraft instrumentation system and the space available, user equipment must comply with the requirements laid down in NAE Laboratory Memoranda FR-63(c) and FR-63(e) (Appendices I & II). These memoranda deal with general mechanical and electrical design requirements and with various environmental, vibration and power input tests which experimental equipment is subjected to prior to being flown on NAE aircraft. Note in particular the Crash Landing load factor requirements for equipment mounted in the T-33 provided in FR-63(c) Table 2.

If pressurized equipment is used in an experiment, individual components will be subject to close scrutiny. Specification/certification details for all high pressure components, for example - pressure vessels, valves, hoses, tubing, fittings, etc. - will be required.

## **7.0 TOXIC MATERIALS**

Toxic or hazardous materials will not normally be allowed since the FRL has very limited capabilities in handling such materials and since experiment packages are located in the same small air volume as the pilot.

Exceptions may be possible where it can be demonstrated either because of the small amounts of material involved, or due to exceptional containment properties of the equipment involved that no hazard exists to the pilot or to other FRL personnel in handling and operating the equipment. It is the responsibility of the user to clearly identify to the FRL any possibly toxic or hazardous materials being considered for use in microgravity experiments.

#### 8.0 SAFETY REVIEW

All experimental equipment and procedures must undergo and pass a FRL safety review prior to flight. In addition to the experimental equipment itself, the user should provide as a minimum the following information for the safety review:

- (a) test plan detailing test objectives and requirements;
- (b) test equipment installation and operation procedures or checklists;
- (c) test equipment structural analysis to include, if applicable, pressure system description and pressure vessel certification;
- (d) test equipment electrical load analysis; and
- (e) hazard identification.

## 9.0 CONCLUDING REMARKS

This report has attempted to cover features, capabilities and limitations of the NAE T-33 Microgravity Facility. Prospective users are encouraged to interact directly with the FRL in the planning stages of their experiments in order to best utilize the extensive capabilities and options available.

**APPENDIX I**

**FRL Laboratory Memorandum FR-63 (c)**

NATIONAL AERONAUTICAL ESTABLISHMENT

NO. FR-63(c)

LABORATORY MEMORANDUM

PAGE \_\_\_\_\_ OF \_\_\_\_\_

FLIGHT RESEARCH LABORATORY

DESIGN REQUIREMENTS FOR THE MOUNTING OF EQUIPMENT  
IN  
FLIGHT RESEARCH AIRCRAFT

PREPARED BY: B. Usher  
April 1967

APPROVED BY: Dr. S.R.M. Sinclair,  
Head,  
Flight Research Laboratory

Reissued: May 1982

NATIONAL AERONAUTICAL ESTABLISHMENT

NO. FR-63(c)

LABORATORY MEMORANDUM

PAGE 1 OF 3

The following is to be used as a guide in designing and calculating the strength of equipment installations in Flight Research aircraft when more specific data for a particular aircraft is not available and should be used in conjunction with Lab. Memo FR-63(a).

DEFINITIONS

- (a) Limit Load - is the maximum load to be expected in service. Limit load deflections shall not prevent safe operation or result in permanent deformation.
- (b) Ultimate Load - is a limit load multiplied by an appropriate factor of safety, which shall not be less than 1.5.
- (c) Limit Load Factor - is the ratio of the limit load to the weight of the equipment.
- (d) Ultimate Load Factor - for crash landing is the ratio of the ultimate crash load to the weight of the equipment.
- (e) Factor of Safety - is a design factor used to provide for the possibility of loads greater than those anticipated in normal conditions of operation, and for uncertainties in design, i.e. may include a fitting factor, bearing factor, etc.

1. NORMAL FLIGHT REQUIREMENTS

1.1 Equipment to withstand normal flight and landing loads, which if torn loose from its fastenings during a crash landing, will not injure personnel, block escape hatches, etc., is to be installed on the strength basis considering all six of the forces acting separately as shown in Table I multiplied by a 1.5 structural factor of safety, to obtain the ultimate load factors.

TABLE I  
LIMIT LOAD FACTORS FOR NORMAL FLIGHT AND LANDING

| <u>Type of Aircraft</u>      | <u>Down</u> | <u>Up</u> | <u>Forward</u>     | <u>Aft.</u> | <u>Lateral</u> | <u>Ref.</u> |
|------------------------------|-------------|-----------|--------------------|-------------|----------------|-------------|
| Convair 580                  | 3.41        | 1.41      | 1.0                | 1.25        | 1.25           | Convair EO  |
| Beech 18                     | 3.36        | 1.35      | 1.25               | 1.5         | 1.5            | FAR 23      |
| Twin Otter                   | 3.36        | 1.35      | 1.25               | 1.5         | 1.5            | FAR 23      |
| Harvard                      | 6.0         | 3.0       | 1.5                | 2.25        | 2.25           | FAR 23      |
| T-33                         | 7.33        | 3.7       | 2.0                | 3.0         | 3.0            | RCAF EO     |
| Bell Helicopter<br>47 Series | 3.5         | 1.0       | See note (c) below |             |                | FAR 27      |
| Bell 205                     | 3.5         | 1.0       |                    | "           |                | FAR 29      |
| Jet Ranger                   | 3.5         | 1.0       |                    | "           |                | FAR 27      |

NOTE:

- (a) The load factors in Table I are to be taken as acting separately and are absolute values.
- (b) Forward, aft and lateral load factors in Table I reference RCAF engineering Report #10.
- (c) Forward, aft and lateral load factors for the four helicopters are taken to be the same as those quoted for the Beech 18.

2 CRASH LANDING REQUIREMENTS

The equipment listed below must be installed in a strong enough manner to withstand crash landing or ditching, and must meet those ultimate load factors laid down in Table II, as well as those in Table I.

2.1 All seats and safety harnesses.

2.2 Any equipment, including ballast weights, which if it came adrift during a crash landing or ditching, may cause injury to any crew member or person on board, or prevent the use of emergency exits or emergency equipment (first aid kits, axes, etc.)

TABLE II  
ULTIMATE LOAD FACTORS FOR CRASH LANDING

| <u>Type of Aircraft</u>      | <u>Down</u> | <u>Up</u> | <u>Forward</u> | <u>Aft.</u> | <u>Lateral</u> | <u>Ref.</u> |
|------------------------------|-------------|-----------|----------------|-------------|----------------|-------------|
| Convair 580                  | 4.5         | 2.0       | 9.0            | -           | 1.5            | FAR 25      |
| Beech 18                     | 4.5         | 3.0       | 9.0            | -           | 1.5            | FAR 23      |
| Twin Otter                   | 4.5         | 3.0       | 9.0            | -           | 1.5            | FAR 23      |
| Harvard                      | 4.5         | 4.5       | 9.0            | -           | 1.5            | FAR 23      |
| T-33                         | 10.0        | 4.5       | 20.0           | -           | 4.0            | MIL-A-8865  |
| Bell Helicopter<br>47 Series | 4.0         | 1.5       | 4.0            | -           | 2.0            | FAR 27      |
| Bell 205                     | 4.0         | 1.5       | 4.0            | -           | 2.0            | FAR 29      |
| Jet Range                    | 4.0         | 1.5       | 4.0            | -           | 2.0            | FAR 27      |

NOTE:

- (a) The load factors in Table II are to be taken as acting separately.

**APPENDIX II**

**FRL Laboratory Memorandum FR-63 (e)**

|                                 |   |                           |
|---------------------------------|---|---------------------------|
| L.O. ....                       | NATIONAL AERONAUTICAL ESTABLISHMENT<br>OTTAWA, CANADA | NO <b>PR-63(e)</b>        |
| FILE .....                      | LABORATORY MEMORANDUM                                 | PAGE <b>1</b> OF <b>8</b> |
| PREPARED BY <b>DPD &amp; BU</b> | SECTION <b>Flight Research Laboratory</b>             | COPY NO                   |
| CHECKED BY <b>SRMS</b>          |   | DATE <b>31 Jan. 1986</b>  |

SECURITY CLASSIFICATION **OPEN**

SUBJECT **ACCEPTANCE TESTING AND INSPECTION OF EXPERIMENTAL  
EQUIPMENT INTENDED FOR USE ON NAE AIRCRAFT**

PREPARED BY **D.F. Daw and B. Usher**

ISSUED TO **All Staff**

Approved by: **Dr. S.R.M. Sinclair**  
**31 January, 1986**

Dates Issued: **22 March, 1985**  
**18 June, 1985**  
**18 October, 1985**  
**31 January, 1986**

THIS MEMORANDUM IS ISSUED TO FURNISH INFORMATION  
IN ADVANCE OF A REPORT. IT IS PRELIMINARY IN CHARACTER,  
HAS NOT RECEIVED THE CAREFUL EDITING OF A REPORT, AND  
IS SUBJECT TO REVIEW.

NATIONAL AERONAUTICAL ESTABLISHMENT

NO.

FR-63(e)

LABORATORY MEMORANDUM

PAGE

2

OF

8

**ACCEPTANCE TESTING AND INSPECTION OF EXPERIMENTAL  
EQUIPMENT INTENDED FOR USE ON NAE AIRCRAFT**

**1.0 Introduction**

Equipment intended for use in or on research aircraft operated by the Flight Research Laboratory of the NAE will be subjected to inspection and testing prior to being accepted for installation. This inspection and testing are required to ensure that the operation of the equipment will in no way compromise the safety of flight.

**2.0 Equipment Subjected to the Inspection and Testing**

This inspection and testing procedure will apply to all equipment intended to be flown in or on NAE aircraft other than the equipment handled by Aircraft Stores and covered by FR-63(d) "Aircraft Stores Procedures". This includes:

- 2.1 All pieces of equipment supplied by agencies for whom the Flight Research Laboratory is providing flying time or services.
- 2.2 All pieces of commercial equipment not built and tested to MIL or equivalent civil specifications.
- 2.3 Any equipment manufactured "in house" by the Flight Research Laboratories and not covered by FR-63(a) "Airworthiness and Flight Safety Procedures".

**3.0 Details of the Inspection and Testing**

**3.1 Mechanical Considerations**

Equipment will be inspected for mechanical suitability to insure that:

- 3.1.1 The structure of the equipment is of strength sufficient to support itself and all the internal components with the appropriate Limit Load Factors as detailed in Table 1 applied.
- 3.1.2 Sheet metal screws have not been used.
- 3.1.3 All nuts are locknut type (lockwashers are not adequate), either nylon insert or all metal.

NATIONAL AERONAUTICAL ESTABLISHMENT

FR-63(e)

NO. .... 3 8

LABORATORY MEMORANDUM

PAGE ..... OF .....

- 3.1.4 Screws and bolts protrude through nuts.
- 3.1.5 Where blind screws or bolts are used, they must be wirelocked in place or used with loctite on assembly.
- 3.1.6 Chassis are not greater than  $17\frac{1}{2}$  inches in width in order to fit into standard 19 inch racks.
- 3.1.7 Large, horizontal P.C. boards have been avoided, but if necessary, are supported to prevent flexing of boards.
- 3.1.8 All internal components, plugs, capacitors, circuit boards, etc. are held in place to prevent them from coming loose during system installation and during aircraft flight. It is not adequate to rely on the wiring to physically support the components.

3.2 Electrical Considerations

The internal electrical wiring will be inspected to ensure that:

- 3.2.1 MS connectors are used on all the power input and power output connections on the chassis and at the terminations of all cables used for supplying power to the equipment.
- 3.2.2 All power inputs to the equipment are fused adequately to safely protect the unit and cabling in the event of an internal fault. Further fuse protection is required for major electronic subsystems and for all power wiring that exits from the main unit.
- 3.2.3 Teflon covered wire of the appropriate size should be used to interconnect plugs, circuit boards, switches, lights, etc. At all terminations heat shrink sleeving should be used. Where possible the wire should be laid in wire runs and mechanically supported.

3.3 Environmental Testing

Equipment will be subjected to environmental testing to cover the range of altitude and temperature consistent with the flight envelope of the aircraft for which the equipment is intended.

NATIONAL AERONAUTICAL ESTABLISHMENT

PR-63(e)  
NO. ....  
PAGE 4 OF 8

LABORATORY MEMORANDUM

3.4 Vibration Testing

The equipment will be vibration tested to MIL-E-5400P specification or to those sections of the specification deemed reasonable for the intended use of the equipment.

3.5 Power Input Testing

The equipment will be tested for variations in power input as per MIL-STD-704C or to those sections of the specification deemed reasonable for the intended use of the equipment.

**4.0 The Inspecting Authority**

The Inspection of incoming equipment will be carried out by the following personnel:

1. The Senior Instrumentation Technician assigned to the project in question.
2. A Design Officer as appointed from the Design Group.
3. Consultants from other groups within the Flight Research Laboratory, if required.

Each member of the Inspection Team will initial and date the appropriate box on the Incoming Acceptance Tag indicating that the piece of equipment has met the required specifications.

**5.0 The NAE Flight Research Incoming Acceptance Tag**

Each piece of incoming equipment will be assigned an Incoming Acceptance Tag by the project technician or end user (project engineer or project manager).

This tag will be attached to the piece of equipment and completed as the piece of equipment proceeds through the inspection and testing procedure. This tag will eventually be removed and retained with the appropriate Aircraft Work Order (see paragraph 7.10).

An example of the Incoming Acceptance Tag is shown in Figure 1.

NATIONAL AERONAUTICAL ESTABLISHMENT

NO. FR-63(e)

LABORATORY MEMORANDUM

PAGE 5 OF 8

## 6.0 Failure to Pass the Inspection or Testing

In the event that the piece of equipment fails either the testing or inspection, the Incoming Acceptance Tag will be marked to suitably indicate this failure. The project engineer, project manager or their designate will return the equipment to the client with a list of the short-comings.

Re-worked equipment will be re-submitted for acceptance inspection and testing but may be considered as a new case.

## 7.0 Procedure to be Followed on Receipt of Equipment Intended for Use on NAE Aircraft

7.1 An Incoming Acceptance Tag will be attached to each piece of equipment by the project technician or end user (project engineer or project manager). The project technician will then have the responsibility of ensuring that the procedures of this section are followed.

7.2 The equipment will be handed over to the project technician who will:

### 7.2.1 Check for adequate documentation.

(All equipment arriving at the Flight Research Laboratory and intended for flight should arrive complete with a full set of documentation. This documentation should include theory of operation, an operational directive, technical manual (including schematics and power requirements), and a maintenance manual. Current calibration data are also required, where applicable.)

### 7.2.2 Check for obvious electrical short-comings.

### 7.2.3 Check for maintainability and serviceability.

(All units should have detachable plugs (MS or similar) at the back of all chassis to facilitate the simple removal of the chassis from the aircraft. A second set of test cables similar to the system on the aircraft should be available to allow bench test and trouble shooting of the system.)

Deficiencies in any of the above three items will be reported to the head of the Instrument Group who will decide on a course of action.

NATIONAL AERONAUTICAL ESTABLISHMENT

FR-63(e)

NO.

6

OF 8

LABORATORY MEMORANDUM

PAGE

OF

- 7.3 The project technician will then give the equipment to the technician in charge of environmental testing to perform the required tests. Either the head of the Instrument Group or the Project Engineer/Manager will specify the environmental testing required.
- 7.4 The technician in charge of environmental testing will perform the required tests and complete the appropriate section of the Incoming Acceptance Tag.
- 7.5 The project technician will then be responsible for requesting the inspections to be carried out by the Inspection Team.
- 7.6 The Inspection Team will inspect the equipment to ensure that the operation of the equipment will in no way compromise the safety of flight and then complete their sections of the Incoming Acceptance Tag. If the equipment is considered to be unsafe to operate in a Flight Research Laboratory aircraft the short-comings, faults, deficiencies, etc. will be listed on the reverse side of the Incoming Acceptance Tag or on a separate sheet if necessary.
- 7.7 The Inspection Team members will notify their respective group heads of any work necessary to upgrade the equipment and the group heads will decide whether or not to undertake the work within the Flight Research Laboratory facilities. The group heads will notify the project manager/engineer of their decision.
- 7.8 The project technician will supply copies of the completed Incoming Acceptance Tag to the head of the mechanical group.
- 7.9 The project technician, who is responsible for the equipment, will retain the equipment until it is required for design work or installation.
- 7.10 At the time the equipment is handed over to the mechanical group for design work or installation the Incoming Acceptance Tag will be removed from the equipment and given to the head of the instrument group for retention in a comprehensive file of completed Incoming Acceptance Tags.

TABLE I  
LIMIT LOAD FACTORS FOR NORMAL FLIGHT AND LANDING

| <u>Type of Aircraft</u>      | <u>Down</u> | <u>Up</u> | <u>Forward</u>     | <u>Aft.</u> | <u>Lateral</u> | <u>Ref.</u> |
|------------------------------|-------------|-----------|--------------------|-------------|----------------|-------------|
| Convair 580                  | 3.41        | 1.41      | 1.0                | 1.25        | 1.25           | Convair EO  |
| Beech 18                     | 3.36        | 1.35      | 1.25               | 1.5         | 1.5            | FAR 23      |
| Twin Otter                   | 3.36        | 1.35      | 1.25               | 1.5         | 1.5            | FAR 23      |
| Harvard                      | 6.0         | 3.0       | 1.5                | 2.25        | 2.25           | FAR 23      |
| T-33                         | 7.33        | 3.7       | 2.0                | 3.0         | 3.0            | RCAF EO     |
| Bell Helicopter<br>47 Series | 3.5         | 1.0       | See note (c) below |             |                | FAR 27      |
| Bell 205                     | 3.5         | 1.0       |                    | "           |                | FAR 29      |
| Jet Ranger                   | 3.5         | 1.0       |                    | "           |                | FAR 27      |

NOTE:

- (a) The load factors in Table I are to be taken as acting separately and are absolute values.
- (b) Forward, aft and lateral load factors in Table I reference RCAF engineering Report no. 10.
- (c) Forward, aft and lateral load factors for the four helicopters are taken to be the same as those quoted for the Beech 18.

NATIONAL AERONAUTICAL ESTABLISHMENT

NO. *FR-63 (e)*

LABORATORY MEMORANDUM

PAGE 8 OF 8

| NAE FLIGHT RESEARCH INCOMING ACCEPTANCE TAG |       |        |      |               |        |      |
|---|-------|--------|------|---------------|--------|------|
| DESCRIPTION                                 |       |        |      |               |        |      |
| MODEL NUMBER                                |       |        |      | AIRCRAFT      |        |      |
| SERIAL NUMBER                               |       |        |      | DATE RECEIVED |        |      |
| ENVIRONMENTAL TESTING                       |       |        |      | INSPECTION    |        |      |
|   | RANGE | SIGNED | DATE | GROUP         | SIGNED | DATE |
| VIBRATION                                   |       |        |      | MECHANICAL    |        |      |
| TEMPERATURE                                 |       |        |      | INSTRUMENT    |        |      |
| ALTITUDE                                    |       |        |      |               |        |      |
| POWER INPUT                                 |       |        |      |               |        |      |
|   |       |        |      |               |        |      |
|   |       |        |      |               |        |      |

FIGURE 1

REPORT DOCUMENTATION PAGE / PAGE DE DOCUMENTATION DE RAPPORT

A/1895-3

|  |                        |   |                           |                                     |
|--|------------------------|---|---------------------------|-------------------------------------|
| REPORT/RAPPORT<br><b>NAE-AN-47</b><br>1a   |                        | REPORT/RAPPORT<br><b>NRC No. 28342</b><br>1b        |                           |                                     |
| REPORT SECURITY CLASSIFICATION<br>CLASSIFICATION DE SÉCURITÉ DE RAPPORT<br><b>UNCLASSIFIED</b><br>2  |                        | DISTRIBUTION (LIMITATIONS)<br><b>UNLIMITED</b><br>3 |                           |                                     |
| TITLE/SUBTITLE/TITRE/SOUS-TITRE<br><b>Access to Microgravity: A Technical Description of the NAE T-33 Microgravity Facility</b><br>4   |                        |   |                           |                                     |
| AUTHOR(S)/AUTEUR(S)<br><b>J.F. Aitken</b><br>5   |                        |   |                           |                                     |
| SERIES/SÉRIE<br><b>Aeronautical Note</b><br>6  |                        |   |                           |                                     |
| CORPORATE AUTHOR/PERFORMING AGENCY/AUTEUR D'ENTREPRISE/AGENCE D'EXÉCUTION<br><br>7   |                        |   |                           |                                     |
| SPONSORING AGENCY/AGENCE DE SUBVENTION<br><b>National Research Council Canada</b><br><b>National Aeronautical Establishment / Flight Research Laboratory</b><br>8  |                        |   |                           |                                     |
| DATE<br><b>October 1987</b><br>9   | FILE/DOSSIER<br><br>10 | LAB. ORDER<br>COMMANDE DU LAB.<br><br>11            | PAGES<br><b>45</b><br>12a | FIGS/DIAGRAMMES<br><b>12</b><br>12b |
| NOTES<br><br>13  |                        |   |                           |                                     |
| DESCRIPTORS (KEY WORDS)/MOIS-CLÉS<br><b>1. Training aircraft (T-33) — microgravity experiments</b><br><b>2. Microgravity — test facilities</b><br><b>3. Reduced gravity — test facilities.</b><br>14   |                        |   |                           |                                     |
| SUMMARY/SOMMAIRE<br><br><p>The National Aeronautical Establishment operates a T-33 aircraft as a facility for short duration microgravity experiments. Details covering sensors available, experiment electrical and mechanical requirements, package size constraints, power available, and requirements for interfacing experiments with aircraft instrumentation system are provided for the microgravity experimenter.</p><br>15 |                        |   |                           |                                     |

END

DATE

FILMED

APRIL

1988

DTIC