

AD-A189 724



INSTRUMENTATION FOR THE CHARACTERIZATION AND
DEVELOPMENT OF MILLIMETER WAVE (U) NORTH CAROLINA STATE
UNIV AT RALEIGH DEPT OF ELECTRICAL AND C... R J TREN
22 JAN 88 AFOSR-TR-88-0033 AFOSR-86-0262 F/O 9/1

1/1

UNCLASSIFIED

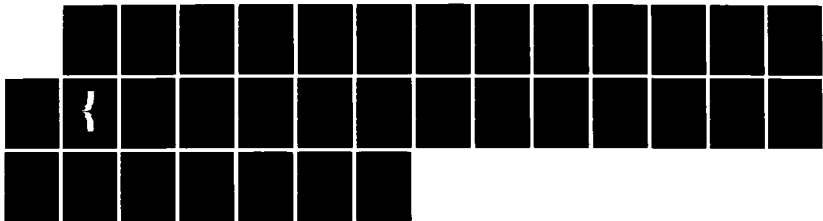
ML

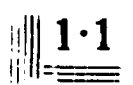
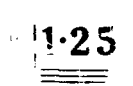

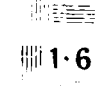
	1.0	2.8	
	1.1	3.15	2.2
	1.25	3.5	2.0
	1.4		1.8
			1.6

AD-A189 724

Instrumentation for the Characterization and Development
of Millimeter Wave Components Compatible
with Monolithic Integration

by

R.J. Trew
Electrical and Computer Engineering Department
North Carolina State University
Raleigh, NC 27695-7911

for

Air Force Office of Scientific Research
Air Force Systems Command, USAF
Bolling AFB, DC 20332-6448

January 22, 1988

Final Report on DoD-URIP Contract No. AFOSR-86-0262

Electrical and Computer Engineering Department
North Carolina State University
Raleigh, NC 27695-7911

REPORT DOCUMENTATION PAGE

1a. REPORT SECURITY CLASSIFICATION		2a. DISTRIBUTION STATEMENT OF REPORT	
2b. SECURITY CLASSIFICATION AUTHORITY		Approved for public release, distribution unlimited	
2c. DECLASSIFICATION/DOWNGRADING SCHEDULE			
4. PERFORMING ORGANIZATION REPORT NUMBER S		5. MONITORING ORGANIZATION REPORT NUMBER S	
		AFOSR TR-88-0033	
5a. NAME OF PERFORMING ORGANIZATION	6a. OFFICE SYMBOL (if applicable)	7a. NAME OF MONITORING ORGANIZATION	
Naval Air Station, Fort Worth, Texas		AFOSR	
6b. ADDRESS (City, State and ZIP Code)		7b. ADDRESS (City, State and ZIP Code)	
Naval Air Station, Fort Worth, Texas 76114		Air Force Research and Development Command, AFOSR, 1715 Avenue of the Stars, Suite 1200, Fort Worth, Texas 76114	
8a. NAME OF FUNDING SPONSORING ORGANIZATION	8b. OFFICE SYMBOL (if applicable)	9. PROCUREMENT INSTRUMENT IDENTIFICATION NUMBER	
AFOSR	AF	AFOSR-TR-88-0033	
8c. ADDRESS (City, State and ZIP Code)		10. SOURCE OF FUNDING NOS.	
AFOSR		PROGRAM ELEMENT NO. PROJECT NO. TASK NO. WORK UNIT NO.	
11. NOTICE (Include security classification)		12. PERSONAL AUTHOR S	
Approved for public release, distribution unlimited		J. W. W. W.	
13a. TYPE OF REPORT	13b. TIME COVERED	14. DATE OF REPORT (Year, Month, Day)	15. PAGE COUNT
Final	FROM: 1987, NOV, 1988, NOV, 1988	1988, NOV, 1988	1
16. SUPPLEMENTARY NOTES			
17. DDC/AD/ASAT CODES		18. SUBJECT TERMS (Continue on reverse if necessary and identify by block number)	
FIELD	GROUP	SUB GR	MM-WAVE, Automatic Network Analysis, W-RANS
19. ABSTRACT (Continue on reverse if necessary and identify by block number)			
<p>The design of a W-RANS automatic network analyzer is presented. The analyzer is implemented with a Hi-Res 486 computer with ANA software which provides real-time measurement capability. The main component in the network analyzer is a parallel W-RANS backward wave oscillator (BWO). This design allows for the direct operation of W-RANS systems, thereby providing for a complete system on-chip. The system will be used for the identification and characterization of W-RANS systems. It will also be used for the identification and characterization of W-RANS systems which are used in W-RANS systems.</p>			
20. DISTRIBUTION AVAILABILITY STATEMENT		21. ABSTRACT SECURITY CLASSIFICATION	
UNCLASSIFIED UNLIMITED SAME AS RPT. USERS		U	
22a. NAME OF RESPONDSING ORGANIZATION	22b. TELEPHONE NUMBER (Include area code)	22c. OFFICE SYMBOL	
AFOSR	817-437-1200	AF	

TABLE OF CONTENTS

	Page
I. INTRODUCTION.....	1
II. NETWORK ANALYZER OVERVIEW.....	2
III. W-BAND NETWORK ANALYZER CONFIGURATION.....	6
3.1 MILLIMETER-WAVE SOURCE AND STABILIZATION.....	8
3.2 TEST SET AND MEASUREMENT ERROR.....	17
3.3 MEASUREMENT CALIBRATION.....	19
3.4 SECOND DOWN CONVERSION STAGE TO THE HP 8510A.....	23
IV. FEATURES OF THE MEASUREMENT SYSTEM.....	26
V. RESEARCH GOALS.....	28

I. INTRODUCTION

This report describes the design and development of a W-band (75-110 GHz) vector automatic network analyzer. The system was funded under the DoD sponsored University Research Instrumentation Program. The W-band system will be located in the Microwave Laboratory located in the Electrical and Computer Engineering Department of North Carolina State University. The equipment funded under this program will interface with an existing Hewlett-Packard 8510A automatic network analyzer and will extend the operating frequency range of this instrument to the millimeter-wave bands. Currently, the system is limited to an upper frequency of 26.5 GHz. The enhanced system will permit research to be performed in the area of millimeter-wave characterization of solid-state devices. In particular, we are interested in performing S-parameter measurements on experimental mm-wave devices in order to determine ultimate frequency and performance limitations. It is anticipated that information of this type will contribute to research directed towards developing optimized solid-state devices for mm-wave applications. The enhanced system will also allow research to be performed in the area of fixturing and de-embedding techniques applicable to mm-wave operation. This area is very important when performing high frequency network analysis, but suitable techniques are not currently well established. The main component of the mm-wave measurement system is a W-band backward wave oscillator

(BWO) source. A state-of-the-art tube has been obtained and this source is capable of producing a stable RF signal with a minimum RF output power of 100 mW across the band. This power level is sufficient to drive mm-wave solid-state devices into nonlinear operation. It is anticipated that the system will, therefore, be suitable for performing research into the nonlinear characteristics of these devices. Research in this area may yield indirect generation techniques for producing improved mm-wave active components.

The design and performance of the enhanced W-band system is described in this report. The report begins with an overview description of vector network analysis techniques. The configuration for the selected system is presented, followed by a description of the primary components employed. The main components of the system consist of the mm-wave source (W-band BWO) and the necessary frequency stabilization circuits, the W-band RF test set and pertinent measurement error models, and the conversion stage to interface the RF data with the data processor and display. Various other features of the network analyzer are also discussed. The report concludes with a summary of system capabilities and planned research goals.

II. NETWORK ANALYZER OVERVIEW

Network analyzers are able to completely characterize linear networks in the frequency domain. The system functions by supplying a source signal to the network under

investigation (generally called the device under test, or DUT). The magnitude and phase of the reflected and transmitted signals from the network are then measured and compared to the incident signal. The complex terminal measurements permit the DUT to be completely and uniquely determined. The measured vector data is generally displayed on polar displays in the form of scattering parameter (S) or impedance (Z) data. Any active or passive network can be investigated, although the technique is generally limited to linear operation. The technique is often employed for large-signal conditions by making appropriate assumptions, and measurements of 'large-signal' S-parameters are often reported. A major problem and source of error in applying the technique to nonlinear conditions is the neglect of harmonic signals.

The generic configuration for a network analyzer is shown in Fig. 1. The network analyzer system includes an RF source to excite the network under investigation. Although any RF source will, in principle, function, accurate phase determination places strict stability requirements upon the source. For this reason, crystal stabilized sources or frequency synthesizers are often employed. The HP 8510A ANA functions best with a stabilized frequency synthesizer. The magnitude and phase of the reflected and transmitted signals from the network under test are sampled with directional couplers and these signals are compared with the incident signal. The signals that result from the comparison process

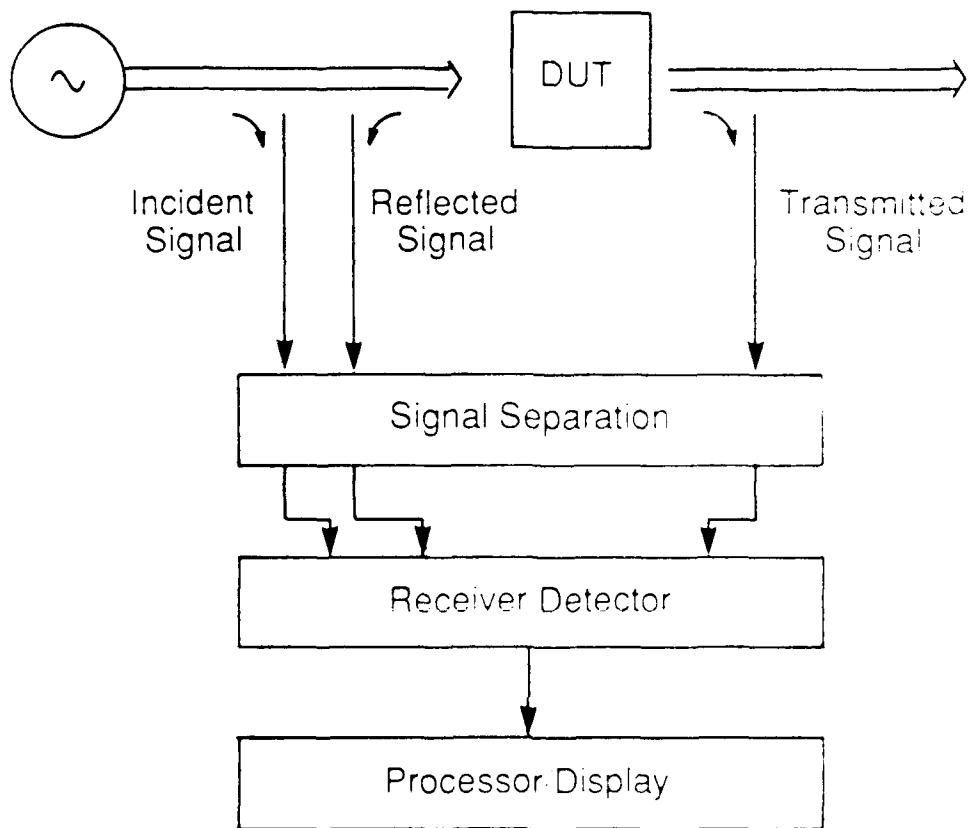

Figure 1. General Automatic Network Analyzer Configuration

represent the net vector responses from the network. This data, when corrected for measurement errors, is sufficient to completely characterize the frequency response of the network.

Measurement errors produce deviations from the true frequency response of the network and the errors must be accounted for in order to obtain an accurate network characterization. One source of measurement error is due to parasitic reactances associated with device mounting structures, packaging, and connector interfaces. The errors associated with these structures are generally repeatable and can, therefore, be identified, characterized and modeled. Calibration standards with known frequency response can be employed to obtain accurate representations for these networks. Once error correction models are determined, the measured network data can be modified to remove the unwanted data. Other sources of measurement error are due to amplitude and phase variations in the source signal used to excite the network and non-ideal responses in the amplitude and phase detectors. These errors are random and not repeatable with frequency. It is generally not possible to correct the data for these errors and therefore, such errors place performance limitations upon the system. Amplitude and phase errors of this type can be removed by employing high quality sources and components with stable characteristics.

The network analyzer can be interfaced with computer control algorithms that contain user defined models of the

DUT and interactively compare the measurement data to the model values. This technique provides a powerful approach to network characterization.

III. W-BAND NETWORK ANALYZER CONFIGURATION

The simplified block diagram for the millimeter-wave network analyzer is shown in Fig. 2. The system includes a W-band backward wave oscillator (BWO) source to excite the network directly at the RF frequency of interest. Alternate techniques employ lower frequency sources in combination with multiplier chains. These techniques are limited in the mm-wave RF power that they can provide. The automatic network analyzer system also includes a microwave synthesizer, the W-band test set, the Hewlett-Packard 8510A automatic network analyzer (includes the processor and display), a second down converter stage to interface the RF with the HP 8510A, and a computer controller (HP series 200 computer).

The BWO serves as the millimeter-wave source and its output is phase and frequency stabilized by means of a phase-locked loop (PLL) circuit. A fraction of the incident, reflected, and transmitted signals from the network under test are sampled with precision directional couplers and applied to the millimeter-wave harmonic mixers. The microwave synthesizer provides the local oscillator (LO) signal used to down convert the mm-wave signals to a frequency 750 MHz. This frequency is required to interface

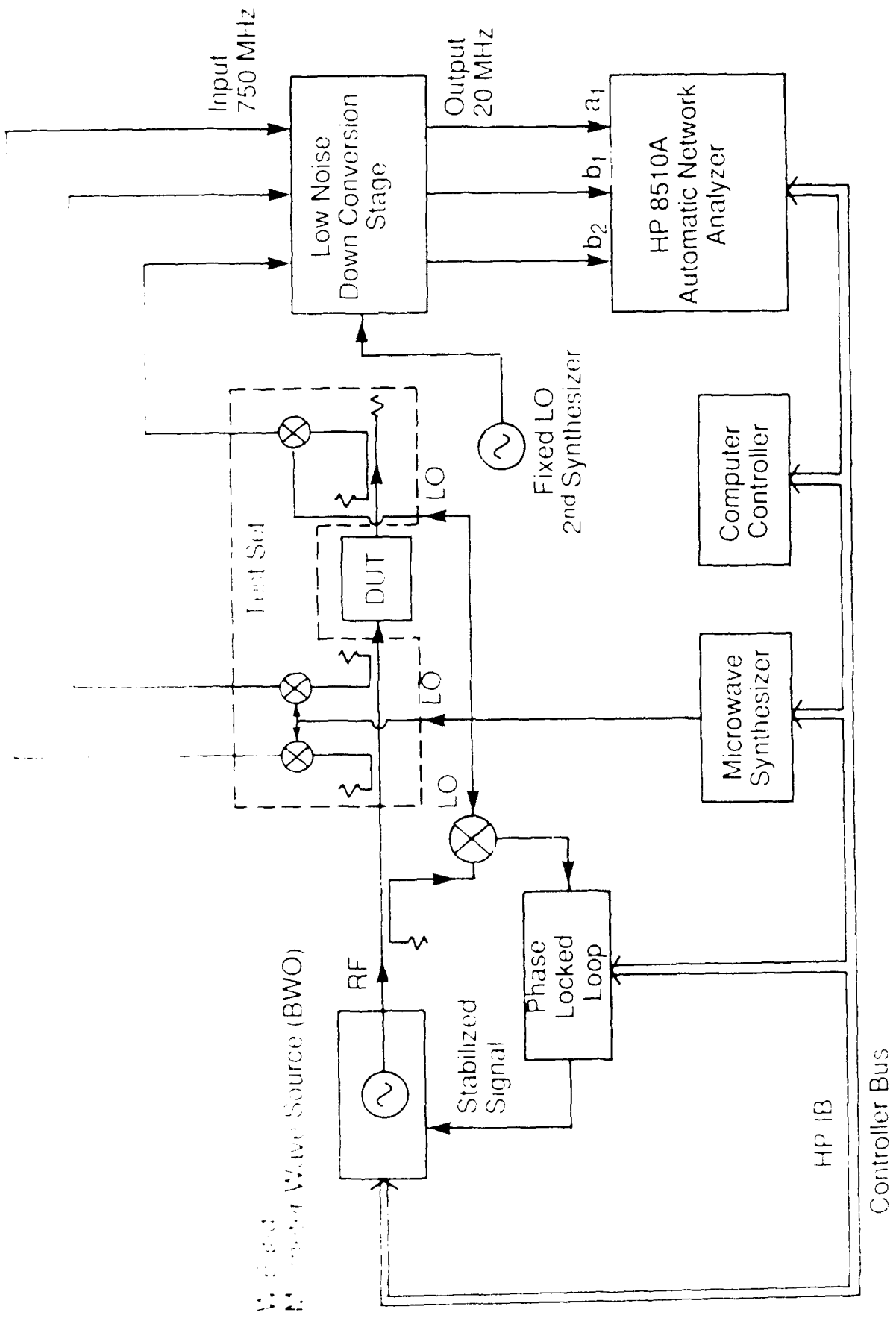

Simplified Block Diagram: W Band Automatic Network Analyzer

with the phase-locked loop stabilizer. A second LO synthesizer, along with a low noise stage for each channel, is used in a second mixer stage to convert the signals to 20 MHz for interfacing with the HP 8510A IF/detector circuit. The signals are processed and displayed by the HP 8510A.

3.1 MILLIMETER-WAVE SOURCE AND STABILIZATION

Desirable characteristics defined in the system design process for the millimeter-wave source are (1) moderate output power, (2) a high degree of phase and frequency stability, (3) full band coverage, (4) electronically tunable to the required frequency by means of the HP-IB controller bus, and (5) low $1/f$ phase noise. Also, it was decided that it would be desirable to obtain a W-band source that could also be used in noise figure and large signal measurements. These additional uses indicate a requirement for RF output powers greater than a minimum of approximately 10-20 mW.

Candidate sources include solid-state devices such as IMPATT and Gunn oscillators, and tube devices such as backward wave oscillators and klystrons. Frequency multiplier chains consisting of a microwave source and either times three or times five multipliers are also often employed to obtain W-band signals. The solid-state sources available for direct generation of W-band signals generally have bandwidths limited to about 4-5 GHz and are mechanically tuned. The frequency multiplier chains can have wideband frequency capability, but generally yield low

output power due to the relatively inefficient harmonic generation process. Also, the frequency multiplier chains are difficult to utilize as stand alone sources for the other applications due to the high level of spurious harmonics produced. Solid-state IMPATT oscillators have adequate RF power output levels and, when combined in multiple source configurations using straddle-band techniques, can provide full-band coverage. IMPATT sources, however, have inherently high $1/f$ phase noise and are, therefore, difficult to employ as stabilized sources, even when phase-locked loop techniques are utilized. Of the vacuum tube devices available, the backward-wave oscillator (BWO) presents the best combination of performance characteristics to satisfy the system requirements. A Micro-Now W-band BWO with a stabilized power supply was selected as the RF source for the system. The Micro-Now source utilizes a W-band BWO tube manufactured by Siemens.

The BWO provides mm-wave RF power over a frequency band extending from 65 to 114 GHz. The BWO functions by modulation of an electron beam caused by interaction with a periodic or slow-wave structure, resulting in the generation of electromagnetic energy. The beam passes from cathode to collector through the slow-wave structure with a velocity determined by the potential difference between the electrodes. The tube is tunable by varying the potential difference between the electrodes. The electromagnetic energy generated in the tube propagates from the collector

to the cathode where it is coupled to the output circuit. The collector and periodic structure operate at ground potential and the cathode is operated at a high negative potential. The output spectrum of the BWO at 110.7 GHz and the RF output power across the frequency band are shown in Figs. 3 and 4. The output power variations shown in Fig. 4 require the inclusion of an RF power leveling loop in the output circuit to provide for a flat output power response. The leveling loop consists of a 10 db W-band directional coupler to sample the RF output from the tube. The sampled signal is applied to a W-band detector that generates a dc voltage proportional to the magnitude of the RF signal. The dc voltage is compared to a reference voltage to generate a difference signal that is then amplified and applied as an error signal to the tube control grid. In this manner, the tube control voltages are modified for relatively constant output power with a variation of approximately +/- 2 db across the entire band.

The BWO signal must be frequency and phase stabilized in order to function with the HP 8510A. The frequency stability of the BWO source must be sufficient to provide a signal within the 1 kHz bandwidth of the 20 MHz IF required by the network analyzer. In order to satisfy this requirement the BWO is stabilized by means of a phase-locked loop.

The frequency stability, phase noise, and resolution of the desired harmonic of the microwave synthesizer are transmitted to the mm-wave signal. A sample of this signal

110.406 GHz

110.406 GHz

110.406 GHz
110.406 GHz
110.406 GHz

CENTER
110.406 GHz

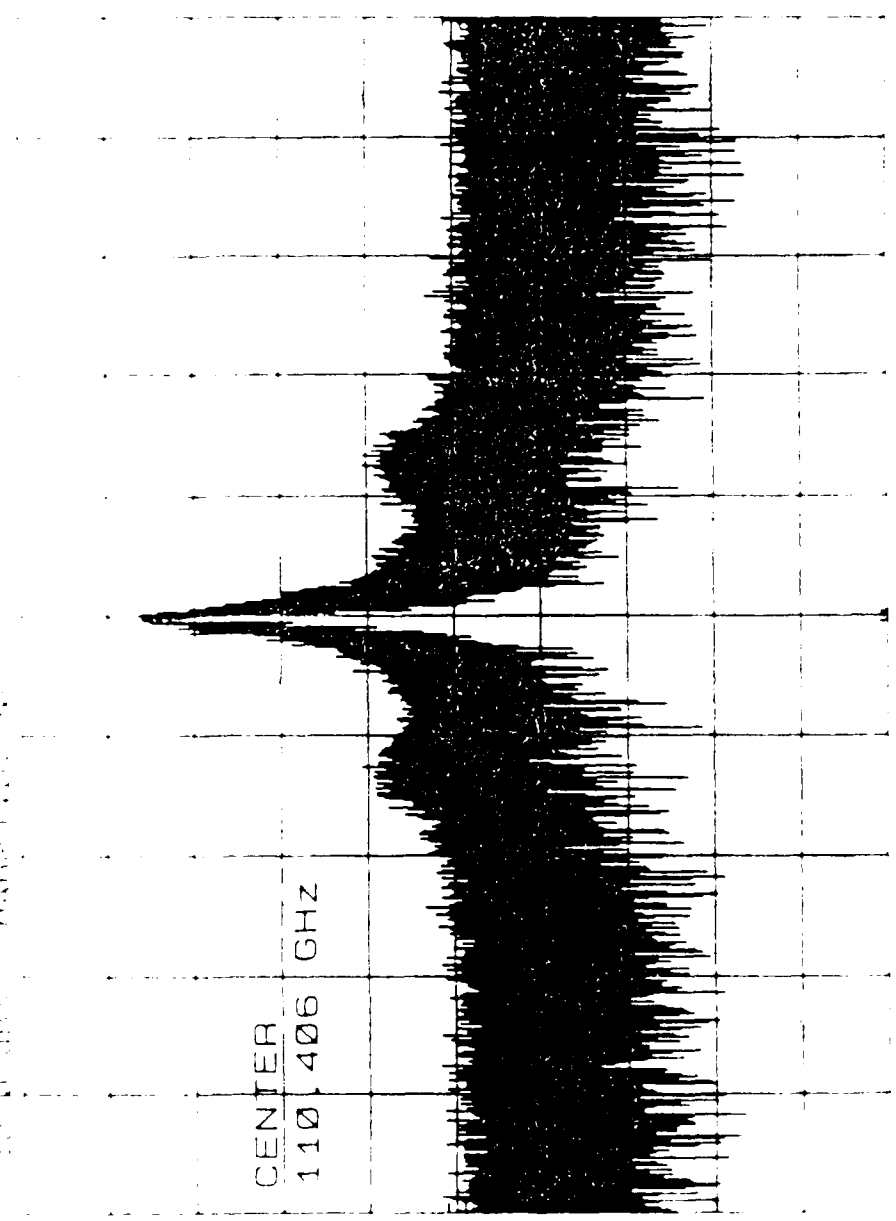

SPAN 175 MHz
200 kHz

VIEW 3 MHz

110.406 GHz
200 kHz

110.406 GHz

is mixed with the microwave local oscillator source in a harmonic mixer to a IF frequency of approximately 750 MHz and applied to the phase-locked loop as shown in Fig. 5. The 750 MHz signal is amplified by an amplifier chain (500 MHz bandwidth, low noise, 75 db gain) that is operated in saturation to provide a constant amplitude signal as the input signal to the succeeding stage. The amplified IF is divided into two paths and compared to the 750 MHz internal reference signal. The reference signal is generated by a low noise oscillator that is phase locked by frequency division to a 10 MHz external reference signal from the HP 8340B time base. The reference signal is divided into two paths by a 90 degree phase shifter. The resulting quadrature signals are mixed with the IF signals and the resulting signals are amplified and mixed together to develop the error signal. This quadrature detection arrangement is used to provide a true indication of phase lock. When the IF signal is phase locked, both quadrature mixers become phase detectors and a dc voltage appears at their output. These dc voltages are compared by a differential amplifier and when they are of correct magnitude, phase lock is indicated. Because the quadrature mixers become phase detectors when the system is phase locked, the output of the cosine detector becomes the phase error signal detector for the system. The output of this detector is amplified and mixed with the frequency error signal at the input of a high output current amplifier configured as an integrator. This amplifier acts as the lag

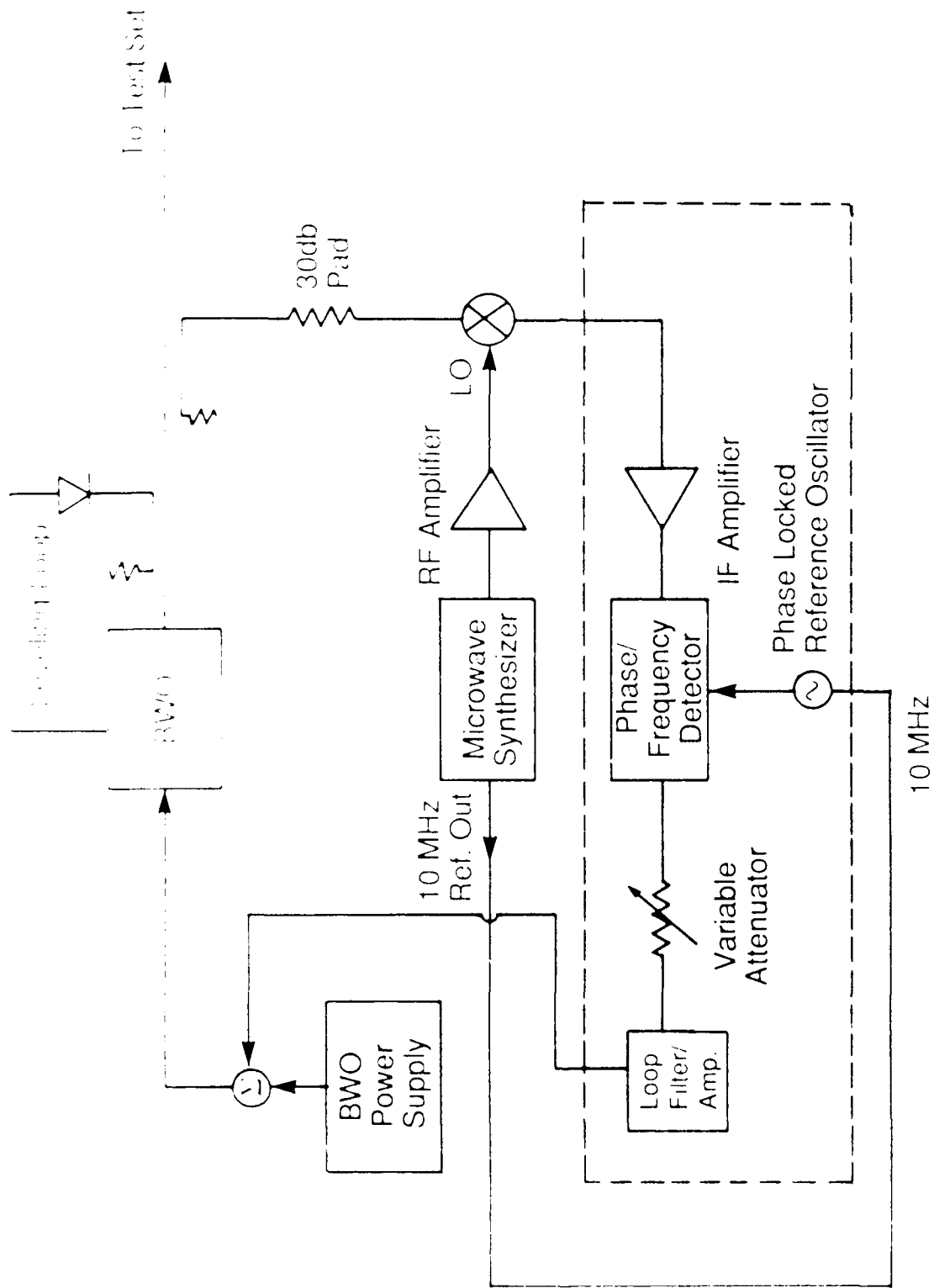

PLL System Diagram

network for the system to compensate for the changes in source-tuning sensitivity encountered over the tuning range of the source. The phase locked loop is shown in Fig. 6.

The PLL is designed to demonstrate an IF sensitivity of -65 dBm with a capture range greater than +/- 100 MHz with a capture time of 20 mS. The frequency deviations of the W-band BWO have been investigated and are within the capture range.

The sequence of phase lock operation is as follows: First, a signal with frequency determined from a tuning curve in the microprocessor of the BWO control unit is produced by the BWO. The HP 8340B is then set to the desired mm-wave frequency plus 750 MHz divided by six (the harmonic number). The microwave synthesizer is phase locked and the BWO is tuned for phase lock. A signal is then sent to the computer controller which instructs the computer to move to the next frequency point and repeat the sequence.

The local oscillator operates at its highest frequency to utilize the lowest harmonic number in the mixers. This results in mixer performance with the lowest conversion loss and lowest noise figure. A LO frequency of 12.5 to 18.33 GHz requires a harmonic number of six in order to cover the full 75 to 110 GHz frequency band. The mixers use GaAs beam lead diodes and have a conversion loss of 22.5 ± 2.5 dB. A 30 dB attenuator is used as an isolator to prevent spurious signals generated in the mixing process from entering the test set.

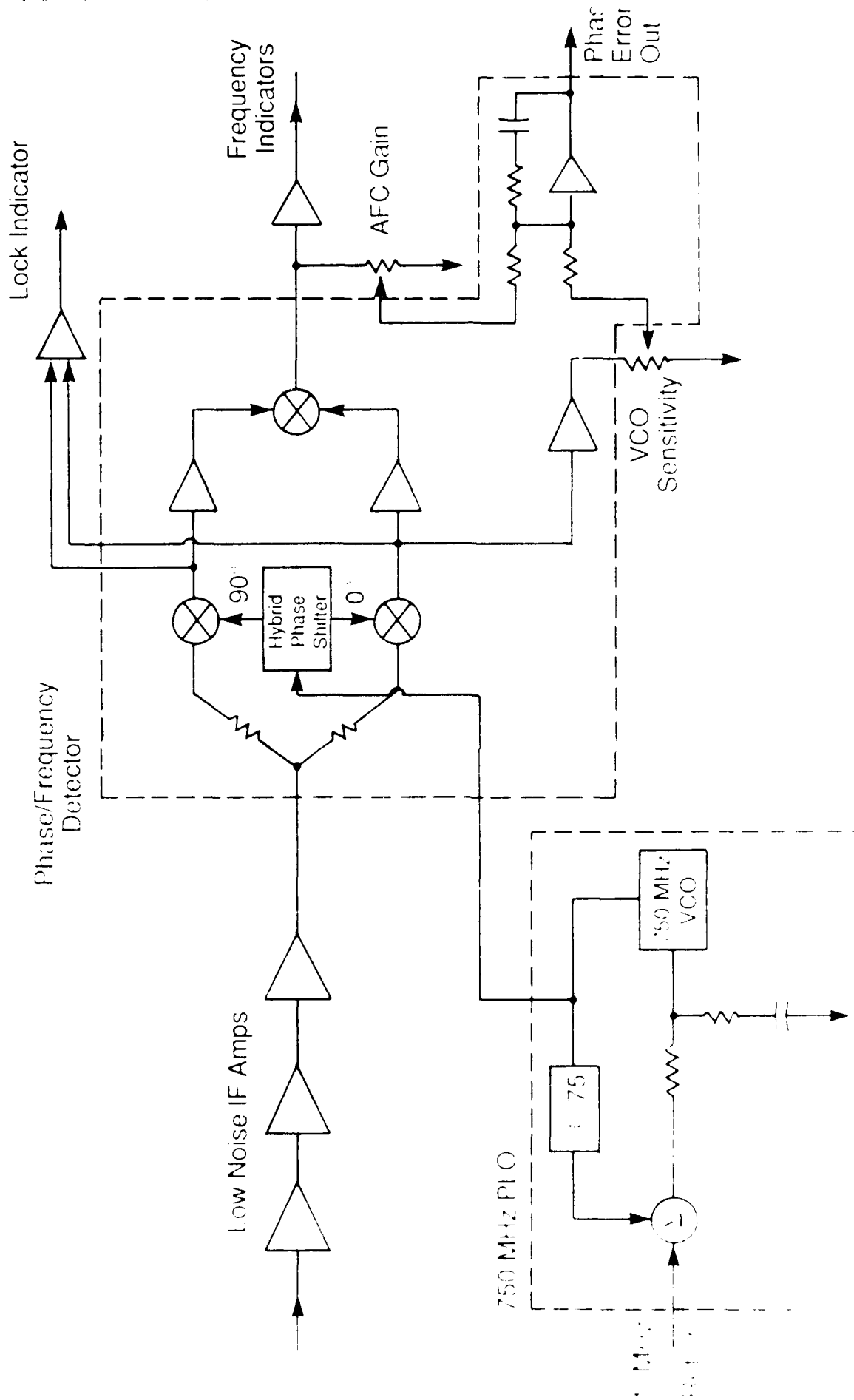

PLL Block Diagram

The phase noise of the BWO when phase locked is shown in Table 1.

Table 1
W-Band BWO Phase Characteristics

Frequency Offset From the Carrier	Single Sideband Noise
1 KHz	-42 dBc/Hz
10 KHz	-50 dBc/Hz
100 KHz	-71 dBc/Hz
1 MHz	-95 dBc/Hz

3.2 TEST SET AND MEASUREMENT ERROR

The function of the test set is to separate the incident, reflected, and transmitted signals from the device under test and down convert them for processing. The separation is performed by precision W-band waveguide directional couplers. The requirements for the couplers are good VSWR (i.e., impedance match), low coupling variation over the frequency band, and high port-to-port isolation and directivity. The system uses 10 dB waveguide directional couplers with full frequency band coverage. The directional couplers have 35 to 40 dB minimum directivity, ± 1 dB variation, and a maximum VSWR of 1.10 to 1.17.

Processing of the signals is performed more efficiently at low frequencies. For this reason the harmonic mixers are

used to down convert the incident, reflected, and transmitted signals containing the magnitude and phase information of interest. The HP 8340B synthesizer is used as a local oscillator and, for reasons of conversion efficiency and noise performance, is operated at the high end of its frequency range in order to allow the mixers to operate at the lowest possible harmonic number. High quality harmonic mixers have been selected for the test set and the mixers are rated with 22.5 +/- 2.5 dB conversion loss at -10 dBm input power over the full W-band. Waveguide isolators with a minimum of 25 dB isolation across the band are located between the directional couplers and harmonic mixers in order to minimize the possibility of spurious mixing products being transmitted to other components of the system. Such a process could reduce the dynamic range of the system by as much as 10 to 30 dB. The local oscillator drives a power amplifier and a four-way power divider to supply energy to the mixers. The amplifier has the following characteristics: 6.5 dB maximum noise figure, 2:1 maximum input and output port VSWR, 22 dBm minimum compression point, and 25 +/- 1 dB gain. Semi-rigid 0.141 inch diameter SMA cables are used to connect the local oscillator to the amplifier and to connect to power divider ports to the mixers. These cables provide excellent phase and frequency stability.

Due to the high cost of precision W-band waveguide components the test set configuration was chosen to minimize

the number of waveguide switches and attenuators. The test set configuration is shown in Fig. 7. The attenuator and switch are programmable and are connected to the HP-IB bus for computer control. The attenuator is used to control the power level to the device under test and is required when characterizing active devices. The attenuation varies from 0 to 50 dB with 0.1 dB resolution. The switch enables the test set to measure both the forward and reverse parameters of the DUT without the need to physically reverse the DUT, a process that can introduce error due to alignment and mismatch variations. The switch has four ports with a minimum isolation of 40 dB. A flexible full band waveguide cable is placed between the reflected and transmitted arms of the test set to provide a means to connect devices under test of various lengths. The cable has good phase stability for the slight degree of flexing usually encountered in connecting and disconnecting various devices.

In order to achieve the maximum phase stability the electrical lengths of the incident and test channels should be the same. If required, it is possible to equalize the electrical lengths of the test channels by the insertion of a length of waveguide in the appropriate directional coupler arms.

3.3 MEASUREMENT CALIBRATION

An ideal vector network analyzer would have a flat frequency response, zero impedance mismatches or RF leakage

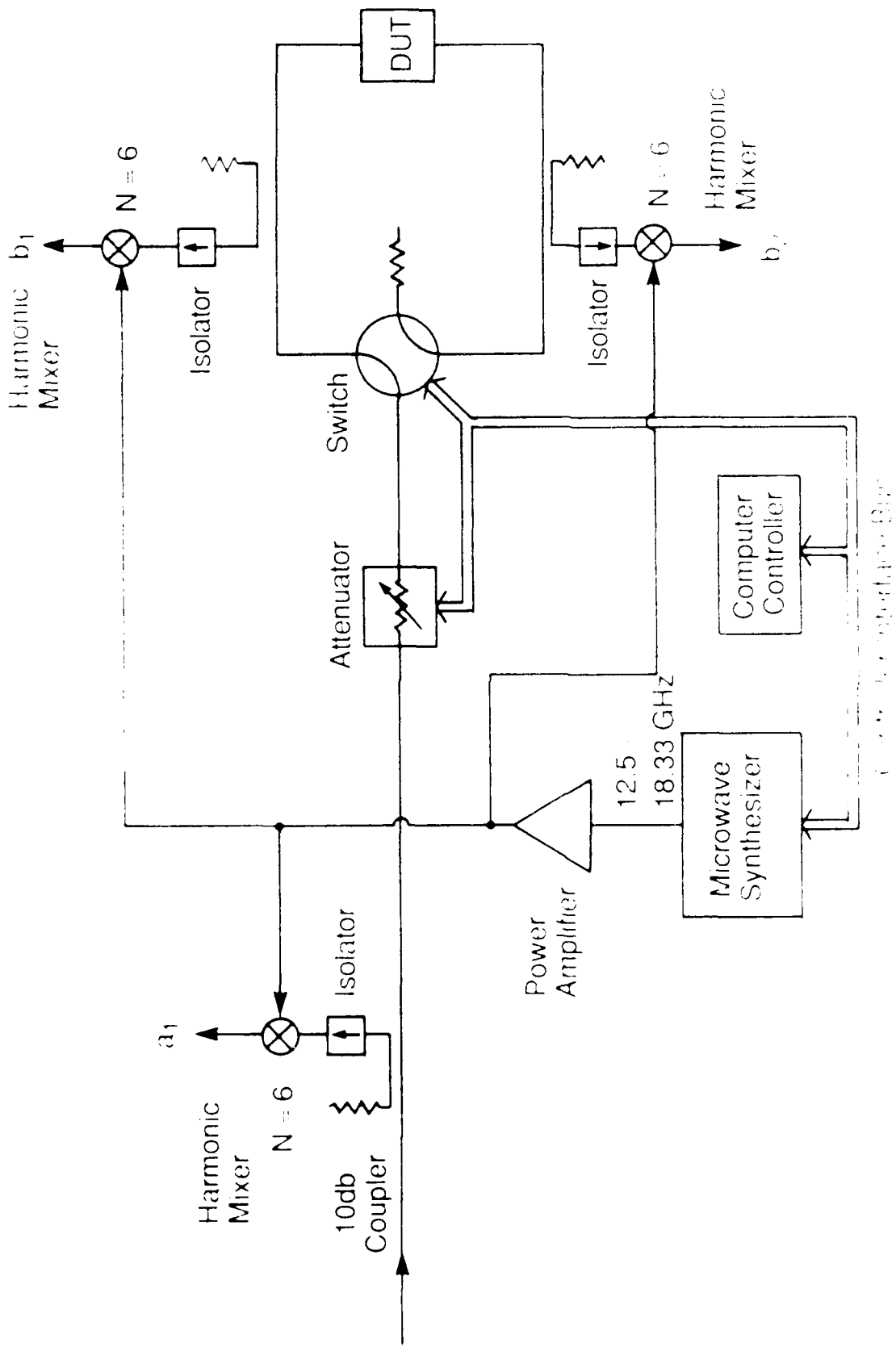
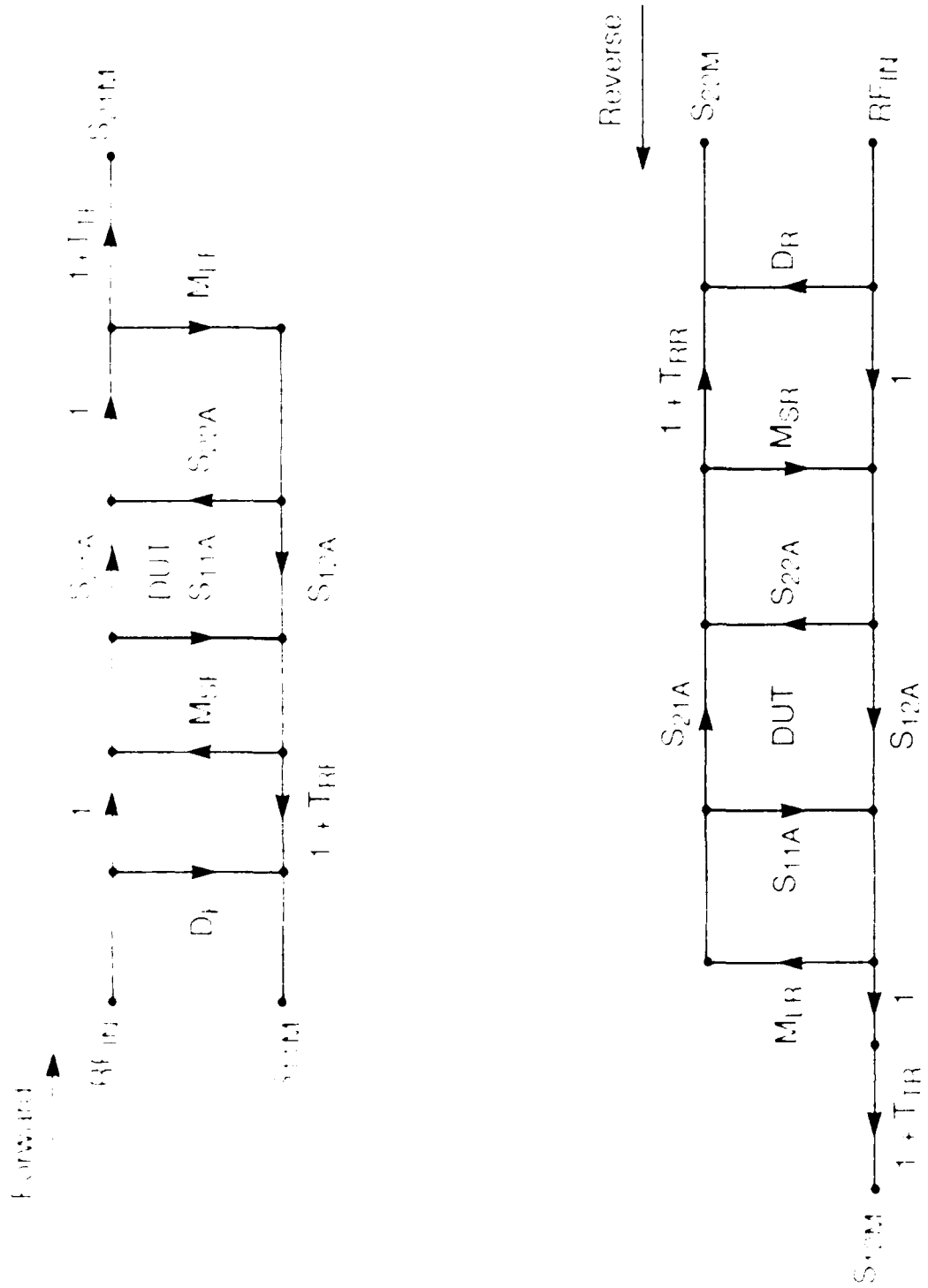

Figure 1. Harmonic Network Analyzer

paths, and infinite isolation between channels. In a practical system, of course, variations from the ideal responses occur and these variations must be accounted for if a true representation of the device under test is to be obtained. Fortunately, many of the variations are systematic and are, therefore, repeatable and predictable. This type of error can be removed from the measured data by characterization and calibration procedures. To perform this procedure known impedance standards are placed at the test set input and output ports and network characterization measurements are performed. Knowledge of the frequency characteristics of the standard allows the measured data to be compared with the known data in order to determine the systematic errors displayed in the measured data. The HP 8510A has a standard definition table that contains the characteristics of the calibration standards to be applied to the error correction routines. This information must be improved for mm-wave applications. The calibration method for a two-port measurement is presented in the following discussion.

The measurement error model for a two-port is shown in Fig. 8. Both forward and reverse models are included and the models are symmetric. For this reason only the forward model will be discussed. The error terms for the forward reflection model are the directivity error (D_F), a reflection tracking error term (T_{RF}) which represents the signal variation in the RF path between the system and the



Two Port Measurement Error Model

device under test, and a source impedance match error (M_{SF}) that describes the measurement system including all adaptors and cables. Three calibration standards with responses that are all different with frequency are required to determine the directivity, reflection tracking, and source mismatch errors. The W-band HP calibration kit employs a 'flush' (a flat plane), a quarter-wavelength offset short, and a fixed load as the reflection standards. The forward transmission error model consists of a transmission response tracking term (T_F) and load mismatch term (M_{LF}) which are similar to the T_{RF} and M_{SF} terms except that they represent two-ports. The transmission calibration assumes a zero-length 'through' standard which is produced by connecting the reflected and transmitted arms together. A precision 10 cm straight section of precision air transmission line is also supplied in the calibration kit. It should be noted that the test set isolation is not included in the error model. This parameter is considered to be part of the device under test and needs to be determined and calibrated in this context. Accurate representation of this parameter is generally a part of the de-embedding procedure.

3.4 SECOND DOWN CONVERSION STAGE TO THE HP 8510A

The signals from the W-band test set are at 750 MHz, which is the required frequency to interface with the phase locked loop. These signals must be converted to 20 MHz \pm 500 Hz in order to be received by the HP 8510A IF/detector

circuit. This second down conversion stage must have very low noise characteristics in order to avoid degradation of the system dynamic range. Important considerations in this regard are the use of low noise amplifiers that have sufficient gain to mask the noise contributions of the other components in the channel, post amplifier filters that reject out of band noise passing through the low noise amplifiers, the use of high quality mixers that possess low conversion loss and high port-to-port isolation, and a local oscillator with low phase noise, high stability, and low spurious and harmonic output.

The low noise amplifiers have a frequency response between 700 and 800 MHz with a noise figure less than 1.0 dB, maximum input and output port VSWR of 1.5:1, and a gain of 32.5 dB. The gain of the amplifier is sufficient to neglect the noise contributions from the other components. The total noise figure of each channel is equal to the noise figure of the amplifiers (1.0 dB).

The local oscillator signal comes from an output channel of a HP 8566B spectrum analyzer. This synthesized source has a fixed tuned output frequency between 2 and 6 GHz with a 1 Hz resolution. The system requires a LO at 730 MHz in order to mix with the 750 MHz input signal and produce the 20 MHz IF signal. The desired LO frequency is obtained by applying a 2.92 GHz signal to a power amplifier to drive a divide-by-four frequency divider to generate the 730 MHz signal. The power amplifier has a 5.0 dB noise figure, 8.0 dB gain, and

a 20 dBm 1 dB compression point. The frequency divider requires a high input power to operate properly and has a low noise figure of approximately 2 dB at 730 MHz, and an insertion loss of 0 dB. The divider also produces harmonic signals at a fairly high level at $1/2 f_0$ (2.92 GHz), f_0 , $3/2 f_0$, $5/2 f_0$, and $3 f_0$.

An output lowpass filter is required to attenuate the harmonic frequencies by about 50 dB. The phase noise levels from the local oscillator stage at 730 MHz are satisfactory and are listed in Table 2.

Table 2
Phase Noise of the 730 MHz Local Oscillator

Offset from carrier	Single sideband noise
1 KHz	-90 dBc Hz
10 KHz	-95 dBc Hz
100 KHz	-110 dBc Hz

The post amplifier bandpass filters have a 10 dB insertion loss and reject the image frequency at 710 MHz by about 45 dB, the intermediate frequency at 20 MHz by 50 dB, and the local oscillator harmonics of f_0 by 55 dB. These filters are required to eliminate signals not in the information bandwidth from the IF signal. The unwanted signals must be eliminated from the system before frequency translation occurs.

The mixers used in the channels have a conversion loss of 5.5 dB with a minimum isolation of 20 dB between ports. The maximum power level into the HP 8510A IF/detector circuit is -10 dBm, which is satisfactory to achieve an adequate dynamic range. The HP 8510A receiver has a 1 kHz bandwidth of about 20 MHz. The complete down conversion stages are shown in Fig. 9.

IV. FEATURES OF THE MEASUREMENT SYSTEM

Frequency or phase shifts in the sources employed in the measurement system can have significant effects upon the phase accuracy of the measured data. To prevent unwanted shifts, the time bases must be synchronized to make the system phase coherent. The HP 8340B output at 10 MHz serves as the external reference to the spectrum analyzer and the phase locked loop. Semi-rigid 0.141 inch diameter SMA cables are used to provide phase stability. The system controller is an HP 9816 computer that controls the switch and attenuator in the test set, sets the measurement frequency and the BWO and local oscillator frequency difference to +750 MHz, acknowledges the 'lock' condition from the HP 8340B and mm-wave phase locked loop, and controls the processing and initialization information to the HP 8510A. The software to provide these functions will be written in HP basic and is currently under development at NCSU.

The W-band vector network analyzer system provides error corrected vector measurements from 75 to 110 GHz with 51,

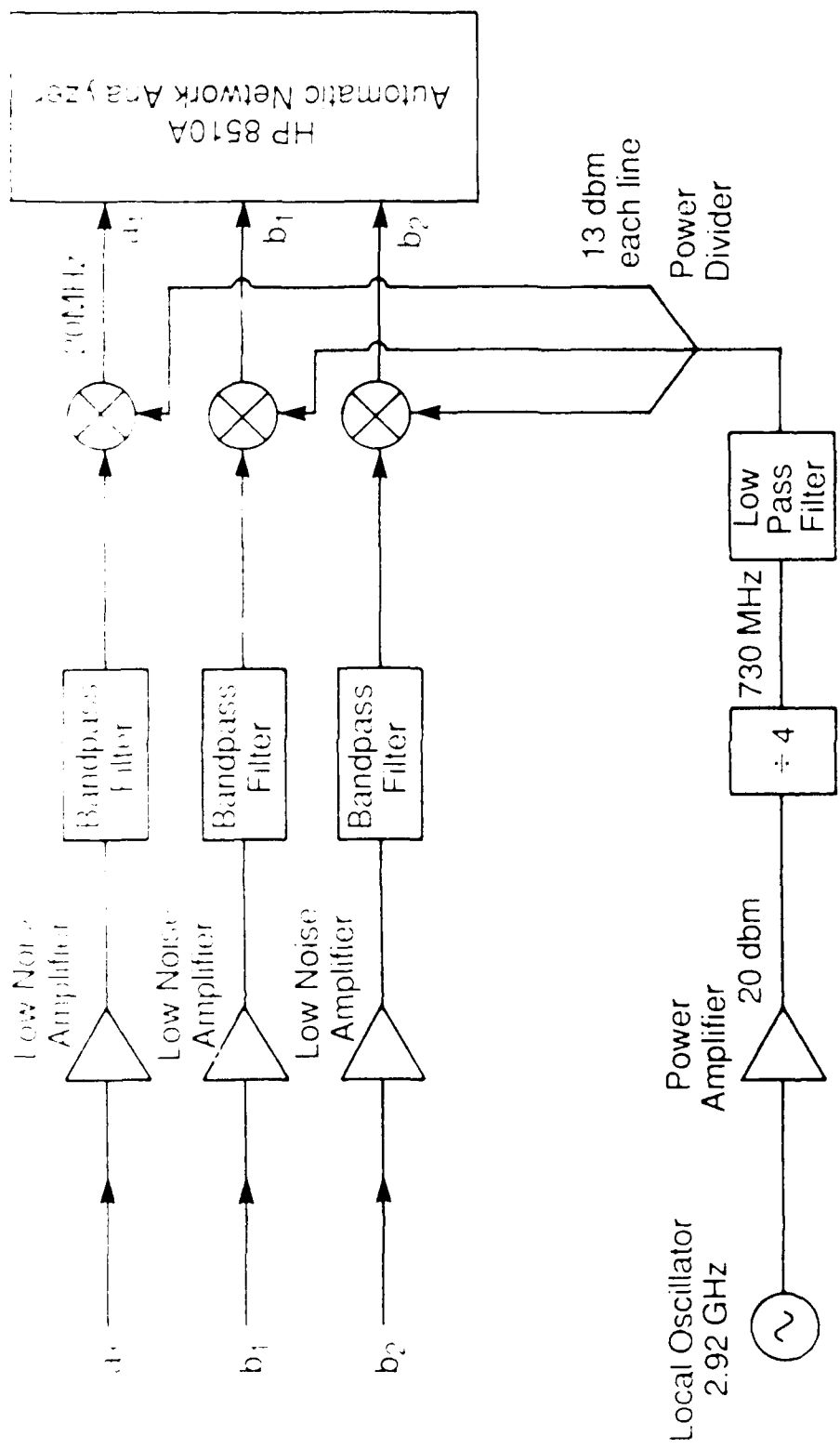

Second Frequency Conversion Stage to the HP 8510A

101, 201, or 401 data points. High resolution narrow band measurements can be performed with resolutions of 218 Hz. The highly stable mm-wave source, when used in conjunction with phase locked loop and low noise frequency conversion techniques, provides a relatively large dynamic range for the measurement of mm-wave components. With an averaging factor of 64 in the measurement system, a dynamic range of approximately 60 dB across the frequency band is expected. Also, time domain measurements are unaffected and can be easily performed. Typical measurement times with a 64 averaging factor are about 240 mS per point, which would require 12 S and 96 S for a full sweep of 51 and 401 points, respectively. Effective measurement accuracy depends upon the calibration device used. With the HP calibration kit, typical measurement port characteristics after measurement calibration for the 75 to 110 GHz band are effective directivity with 35 dB, effective port match of 35 dB, and effective frequency response of +/- 0.1 dB.

V. RESEARCH GOALS

The purpose of the system described in this report is to establish a tool for the accurate characterization of components at W-band. In particular, the system will permit accurate vector network characterization of both active and passive components that may be useful at mm-wave frequencies. In particular, we are interested in investigating the operation of three terminal solid-state

devices that are candidates for mm-wave integrated circuit applications. Typical devices include GaAs MESFETs and compound semiconductor heterojunction devices such as MODFETs, Permeable Base Transistors (PBTs), and Bipolar Transistors. State-of-the-art devices will be obtained from industry and evaluated with the W-band system. Suitable personal contacts have been established with relevant industries for obtaining sample devices. It is anticipated that this system will contribute to the understanding of both the operation and limitations of these devices.

This research will require investigations of new error models and calibration methods applicable to W-band operation. In particular, RF coupling, leakage, and radiation questions need to be addressed. Device fixturing design must be considered if accurate measurements are to be performed. It is anticipated that the W-band system will permit NCSU to propose significant research programs in the future in which these and other questions will be addressed.

END

DATE

FILMED

APRIL

1988

DTIC.