

AD-A189 812

PERFORMABILITY MODELING BASED ON REAL DATA: A CASE
STUDY(U) ILLINOIS UNIV AT URBANA COMPUTER SYSTEMS GROUP
M C HSUEH ET AL DEC 87 CSG-76 N00014-84-C-0149

171

UNCLASSIFIED

F/G 12/7

ML



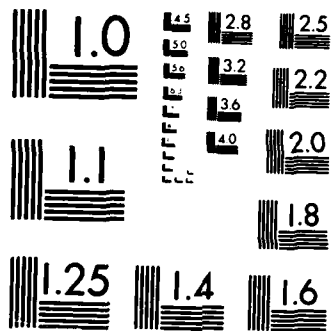

MICROCOPY RESOLUTION TEST CHART
NATIONAL BUREAU OF STANDARDS-1963-A

AD-A189 832

COORDINATED SCIENCE LABORATORY
College of Engineering

2

DTIC FILE COPY

PERFORMABILITY MODELING BASED ON REAL DATA: A CASE STUDY

M. C. Hsueh
R. K. Iyer
K. S. Trivedi

DTIC
ELECTE
JAN 14 1988
S D

UNIVERSITY OF ILLINOIS AT URBANA-CHAMPAIGN

Approved for Public Release. Distribution Unlimited.

REPORT DOCUMENTATION PAGE

1a. REPORT SECURITY CLASSIFICATION Unclassified		1b. RESTRICTIVE MARKINGS None	
2a. SECURITY CLASSIFICATION AUTHORITY		3. DISTRIBUTION / AVAILABILITY OF REPORT Approved for public release; distribution unlimited	
2b. DECLASSIFICATION / DOWNGRADING SCHEDULE			
4. PERFORMING ORGANIZATION REPORT NUMBER(S) UIIU-ENG-87-2272 (CSG 76)		5. MONITORING ORGANIZATION REPORT NUMBER(S)	
6a. NAME OF PERFORMING ORGANIZATION Coordinated Science Lab University of Illinois	6b. OFFICE SYMBOL (if applicable) N/A	7a. NAME OF MONITORING ORGANIZATION NASA, IBM, JSEP, and AFOSR	
6c. ADDRESS (City, State, and ZIP Code) 1101 W. Springfield Avenue Urbana, IL 61801		7b. ADDRESS (City, State, and ZIP Code) IBM: T.J. Watson NASA Research Center Langley Research Ctr. P.O. Box 218 Hampton, VA 23665 Yorktown Hts, NY	
8a. NAME OF FUNDING / SPONSORING ORGANIZATION NASA IBM JSEP AFOSR	8b. OFFICE SYMBOL (if applicable)	9. PROCUREMENT INSTRUMENT IDENTIFICATION NUMBER 10598 NASA: NAG-1-613 JSEP: N00014-84-C-0149 AFOSR-84-0132	
8c. ADDRESS (City, State, and ZIP Code) See block 7b.		10. SOURCE OF FUNDING NUMBERS	
		PROGRAM ELEMENT NO.	PROJECT NO.
		TASK NO.	WORK UNIT ACCESSION NO.
11. TITLE (Include Security Classification) Performability Modeling Based on Real Data: A Case Study			
12. PERSONAL AUTHOR(S) Hsueh, M. C.; Iyer, R. K.; Trivedi, K. S.			
13a. TYPE OF REPORT Technical	13b. TIME COVERED FROM TO	14. DATE OF REPORT (Year, Month, Day) December 1987	15. PAGE COUNT 21
16. SUPPLEMENTARY NOTATION			
17. COSATI CODES		18. SUBJECT TERMS (Continue on reverse if necessary and identify by block number)	
FIELD	GROUP	SUB-GROUP	
		Error, workload, measurements, semi-Markov, performability, performance measurement	
19. ABSTRACT (Continue on reverse if necessary and identify by block number)			
<p>This paper describes a measurement-based performability model based on error and resource usage data collected on a multi-processor system. A method for identifying the model structure is introduced and resulting model is validated against real data. Model development from the collection of raw data to the estimation of the expected reward is described. Both normal and error behavior of the system are characterized. The measured data show that the holding times in key operational and error states are not simple exponentials and that a semi-Markov process is necessary to model the system behavior. A reward function, based on the service rate and the error rate in each state, is then defined in order to estimate the performability of the system and to depict the cost of different types of errors.</p>			
20. DISTRIBUTION / AVAILABILITY OF ABSTRACT <input checked="" type="checkbox"/> UNCLASSIFIED/UNLIMITED <input type="checkbox"/> SAME AS RPT. <input type="checkbox"/> DTIC USERS		21. ABSTRACT SECURITY CLASSIFICATION Unclassified	
22a. NAME OF RESPONSIBLE INDIVIDUAL		22b. TELEPHONE (Include Area Code)	22c. OFFICE SYMBOL

UNCLASSIFIED

Office of Naval Research
800 N. Quincy St.
Arlington, VA 22217

Air Force Office of Scientific Research
Bolling Air Force Base
Washington, D.C. 20332

PERFORMABILITY MODELING BASED ON REAL DATA : A CASE STUDY

M.C. Hsueh, R.K. Iyer † and K.S. Trivedi ‡

This paper describes a measurement-based performability model based on error and resource usage data collected on a multi-processor system. A method for identifying the model structure is introduced and resulting model is validated against real data. Model development from the collection of raw data to the estimation of the expected reward is described. Both normal and error behavior of the system are characterized. The measured data show that the holding times in key operational and error states are not simple exponentials and that a semi-Markov process is necessary to model the system behavior. A reward function, based on the service rate and the error rate in each state, is then defined in order to estimate the performability of the system and to depict the cost of different types of errors.

Index terms : error, workload, measurements, semi-Markov, performability.

M.C. Hsueh and R.K. Iyer are with the Computer Systems Group, Coordinated Science Laboratory, University of Illinois at Urbana-Champaign, Urbana, IL 61801

K.S. Trivedi is with the Computer Science Department, Duke University, Durham, NC 27706



Accession For	
NTIS CRA&I	<input checked="" type="checkbox"/>
DTIC TAB	<input type="checkbox"/>
Unannounced	<input type="checkbox"/>
Justification	
By	
Distribution/	
Availability Codes	
Dist	Avail and/or Special
A-1	

† This work was supported in part by NASA grant NAG-1-613, in part by the IBM Corporation and in part by the Joint Services Electronics Program (U.S. Army, U.S. Navy, U.S. Air Force) under contract number N00014-84-C-0149.

‡ This work was supported by the Air Force Office of Scientific Research under contract AFOSR-84-0132.

1. Introduction

Analytical models for hardware failure have been extensively investigated in the literature along with performability issues [1]. Although the time for different components to fail is usually assumed to be exponentially distributed, time-dependent failure rates and graceful degradation have been considered [2]. Automatic availability evaluation, assuming a Markov models, is discussed in [3]. A job/task flow based model is described in [4], where failure occurrence is assumed to be a linear function of the service requests from a job/task flow. As shown in [5], this linear assumption may result in underestimating the effect of the workload, especially when the load is high. A summary of research in software reliability growth models is discussed in [6]; run-time software reliability modeling is discussed in [7].

Although many authors have addressed the modeling issue and have significantly advanced the state of the art, none have addressed the issue of how to identify the model structure. Further, very few of either the hardware or the software models have been validated with real data. Exceptions are the joint hardware/software model discussed in [8] and, a measurement-based model of workload dependent failures discussed in [5]. Both, however, describe only the external behavior of the system and thus do not provide insight into component-level behavior.

In this paper we build a semi-Markov model to describe the resource-usage/error/recovery process in a large mainframe system. The model is based on one year of low-level error and performance data collected on a production IBM 3081 system running under the MVS operating system. The 3081 system consisted of dual processors with two multiplexed channel sets. Both the normal and erroneous behavior of the system are modeled. A reward function, based on the service rate and the error rate in each state, is defined in order to estimate the performability of the system, and to depict the cost of different error types and recovery procedures. Two key contributions of this paper are:

- (1) A method for identifying a model-structure for the resource-usage/error/recovery process is introduced and the resulting model is validated against real data.

- (2) It is shown that a semi-Markov model may better represent system behavior as opposed to a Markov model.

2. Resource Usage Characterization

In this section we identify a state-transition model to describe the variation in system activity. System activity was characterized by measuring a number of resource usage parameters. A statistical clustering technique was then employed to identify a small number of representative states.

The resource usage data were collected by sampling, at pre-determined intervals, a number of resource usage meters, using the IBM MVS/370 system Resource Measurement Facility (RMF). A sample-time of 500 milliseconds was used in this study. Four different resource usage measures were used:

- CPU - fraction of the measured interval for which the CPU is executing instructions.
 CHB - fraction of the measured interval for which the channel was busy and the CPU was in the wait state (this parameter is commonly used to measure the degree of contention in a system)
 SIO - number of successful Start I/O and Resume I/O instructions issued to the channel
 DASD - number of requests serviced on the direct access storage devices

At any interval of time the measured workload is represented by a point in a 4-dimensional space. (CPU, CHB, SIO, DASD). Statistical cluster analysis is used to divide the workload into similar classes according to a pre-defined criterion. This allows us to concisely describe the dynamics of system behavior and extract a structure that already exists in the workload data.¹

Each cluster (defined by its centroid) is then used to depict a system state and, a state-transition diagram (consisting of inter-cluster transition probabilities and cluster sojourn times) is developed. A k -means clustering algorithm [10] is used for cluster analysis. The algorithm partitions an N -dimensional population into k sets on the basis of a sample. The k non-empty clusters sought, C_1, C_2, \dots, C_k , are such that the sum of the squares of the Euclidean distances of the cluster

members from their centroids, $\sum_{j=1}^k \sum_{x_i \in C_j} ||x_i - \bar{x}_j||^2$, is minimized, where \bar{x}_j is the centroid of cluster

¹Similar clustering techniques are also used for workload characterization in [9].

C_j .

Two types of workload clusters were formed. In the first case CPU and CHB were selected to be the workload variables. This combination was found to best describe the CPU-bound load (nearly 60% of the observations have a CPU usage greater than 0.72). In the second case the clusters were formed considering SIO and DASD as the workload variables. This combination was found to best describe the I/O workload. In this paper, only the results for CPU-bound load clusters are presented. Details of I/O activity can be found in [11]. Table 1 shows the results of the clustering operation. The table shows that about 36% of the time the CPU was heavily loaded (0.96) and almost 76% of the time the CPU load was above 0.5. Since the measured system consisted of two-processors, we may say that 76% of the time at least one of the processors is busy. A state-transition diagram of CPU-bound load activity is shown in Figure 1. Note that a null state, W_0 , has been incorporated to represent the state of the system during the non-measured period. The time spent in the null state was assumed to be zero. The transition probability from state i to state j , p_{ij} , was estimated from the measured data using:

$$p_{ij} = \frac{\text{observed no. of transitions from state } i \text{ to state } j}{\text{observed no. of transitions from state } i}$$

Cluster id	% of obs	Mean of CPU	Mean of CHB	Std dev of CPU	Std dev of CHB
W_1	7.44	0.0981	0.1072	0.0462	0.0436
W_2	0.50	0.1126	0.5525	0.0433	0.0669
W_3	2.73	0.1547	0.2801	0.0647	0.0755
W_4	12.41	0.3105	0.1637	0.0550	0.0459
W_5	0.74	0.3639	0.3819	0.0365	0.1923
W_6	17.12	0.5416	0.1287	0.0560	0.0511
W_7	22.58	0.7207	0.0848	0.0576	0.0301
W_8	36.48	0.9612	0.0168	0.0362	0.0143
R^2 of CPU = 0.9724					
R^2 of CHB = 0.8095					
overall R^2 = 0.9604					

R^2 : the square of correlation coefficient

Table 1. Characteristics of CPU-bound workload clusters

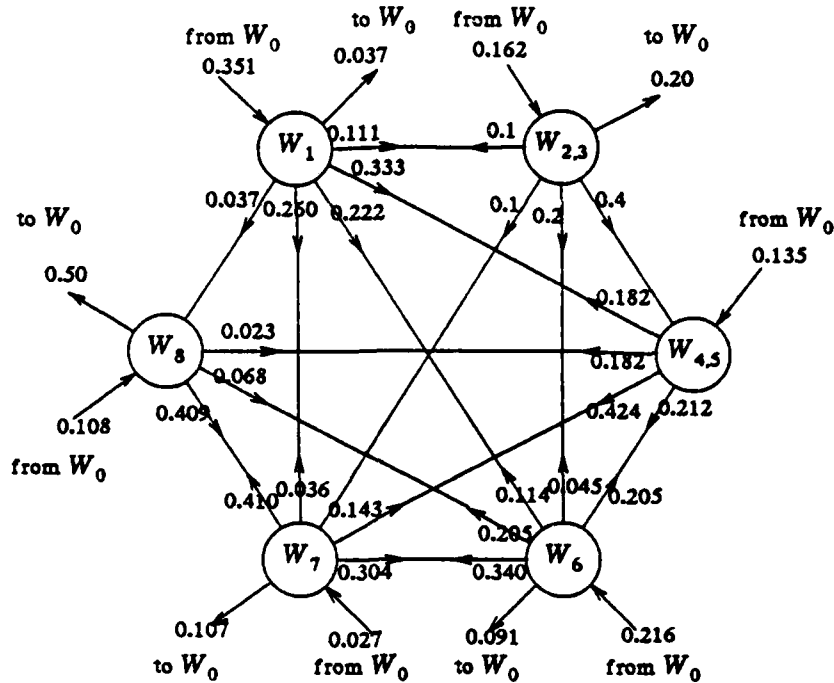

Figure 1. State-transition diagram of CPU-bound load

In the next section the characterization of the errors and the recovery process is discussed. The appropriate error and recovery states are identified for subsequent use in developing an overall model.

3. Error and Recovery Characterization

The IBM system has built-in error detection facilities and there are many provisions for hardware and software initiated recovery through retry and redundancy. The error and recovery data are automatically logged by the operating system as the errors occur. On the occurrence of an error the operating system creates a time-stamped record describing the error, the state of the machine at the time of the error and, the result of the hardware and/or software attempts to recover from the error. Details of this logging mechanism are described in [12]. Due to the manner in which errors are detected and reported in a computer system, it is possible that a single fault may manifest itself as more than one error, depending on the activity at the time of the error. The

different manifestations may not all be identical [13]. The system recovery usually treats these errors as isolated incidents. Thus, the raw data can be biased by error records relating to the same problem. In order to address this problem, two levels of data reduction were performed. First, a coalescing algorithm described in [5] was used to analyze the data and merge observations which occur in rapid succession and relate to the same problem. Next, a reduction technique described in [13] to automatically group records most likely to have a common cause was used. By using these two methods, the errors were classified into five different classes. These classes are called error events since they may contain more than one error and are explained below:

- CPU : Errors which affect the normal operation of the CPU; may originate in the CPU, in the main memory, or in a channel
- CHAN : Channel errors (the great majority are recovered)
- DASD : Disk errors, recoverable (by data correction, hardware instruction retry or software instruction retry) and non-recoverable disk
- SWE : Software incidents due to invalid supervisor calls, program checks and other software exception conditions
- MULT : Multiple errors affecting more than one type of component (i.e., involving more than one of the above)

Table 2 lists the frequencies of different types of errors. Notice that about 17% of errors are classified as multiple errors (MULT). A MULT error is mostly due to a single cause but the fault has non-identical manifestations, provoked by different types of system activity. Since the manifestations are non-identical, recovery may be complex and hence can (as will be seen later) impose considerable overhead on the system.

Type of error	Frequency	Percent
CPU	2	0.04
CHAN	119	2.23
MULT	924	17.33
SWE	1923	36.07
DASD	2364	44.33
total	5332	100.00

Table 2. Frequency of errors

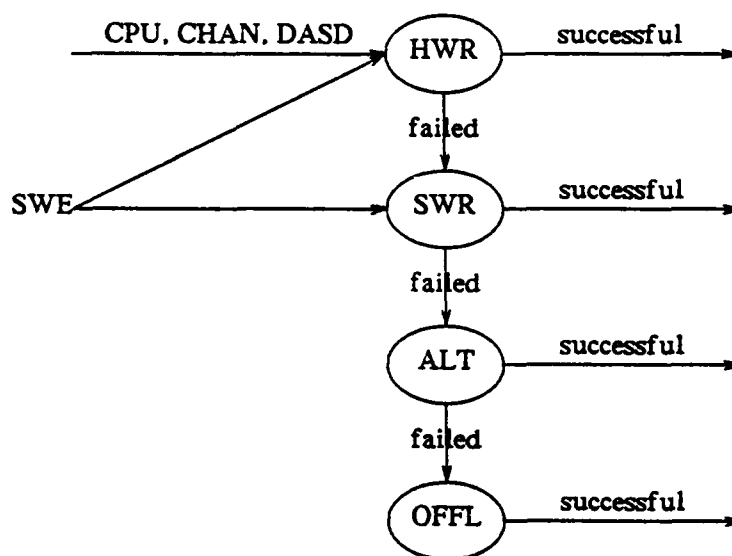

Figure 2. Flow chart of recovery processes

The recovery procedures were divided into four categories based on recovery cost, which was measured in terms of the system overhead required to handle an error. The lowest level (hardware recovery), involves the use of an error correction code (ECC) or hardware instruction retry and has minimal overhead. If hardware recovery is not possible (or unsuccessful), software controlled recovery is invoked. This could be simple, e.g., terminating the current program or task in control, or complex, e.g., invoking specially designed recovery routine(s) to handle the problem. The third level, alternative (ALT), involves transferring the tasks to functioning processor(s) when one of the processors experiences an un-recoverable error. If no on-line recovery is possible, the system is brought down for off-line (OFFL) repair. Figure 2 shows a flow chart of the recovery process. The time spent in each recovery state was taken to be constant, since each recovery type except OFFL requires almost constant overhead.²

² Hardware recovery involves hardware instruction retry or ECC correction. The maximum number of retries is predetermined. Each CPU has a 26-nanosecond machine cycle time and the disk seek time is about 25 milliseconds. We estimate a worst case hardware recovery cost of 0.5 seconds, i.e. incorporating twenty I/O retries: ten through the original I/O path and another ten through an alternative I/O path if the alternative is available. This, of course, over estimates the cost of hardware retry used for the CPU errors. Similarly, the worst-case software recovery time was estimated to be 1 second. The ALT state was not evaluated since it did not occur in the data. For OFFL the time was calculated to be 1 hour based on our experience and through discussion with maintenance engineers.

4. Resource-Usage/Error/Recovery Model

In this section we combine the separate workload, error and recovery models developed into a single model shown in Figure 3. The null state W_0 is not shown in this diagram. The model has three different classes of states: normal operation states (S_N), error states (S_E), and recovery states (S_R). Under normal conditions, the system makes transitions from one workload state to another. The occurrence of an error results in a transition to one of the error states. The system then goes into one or more recovery modes after which, with a high probability, it returns to one of the "good" workload states³. The state transition diagram shows that nearly 98.3% of hardware recovery requests and 99.7% of software recovery requests are successful. Thus the error

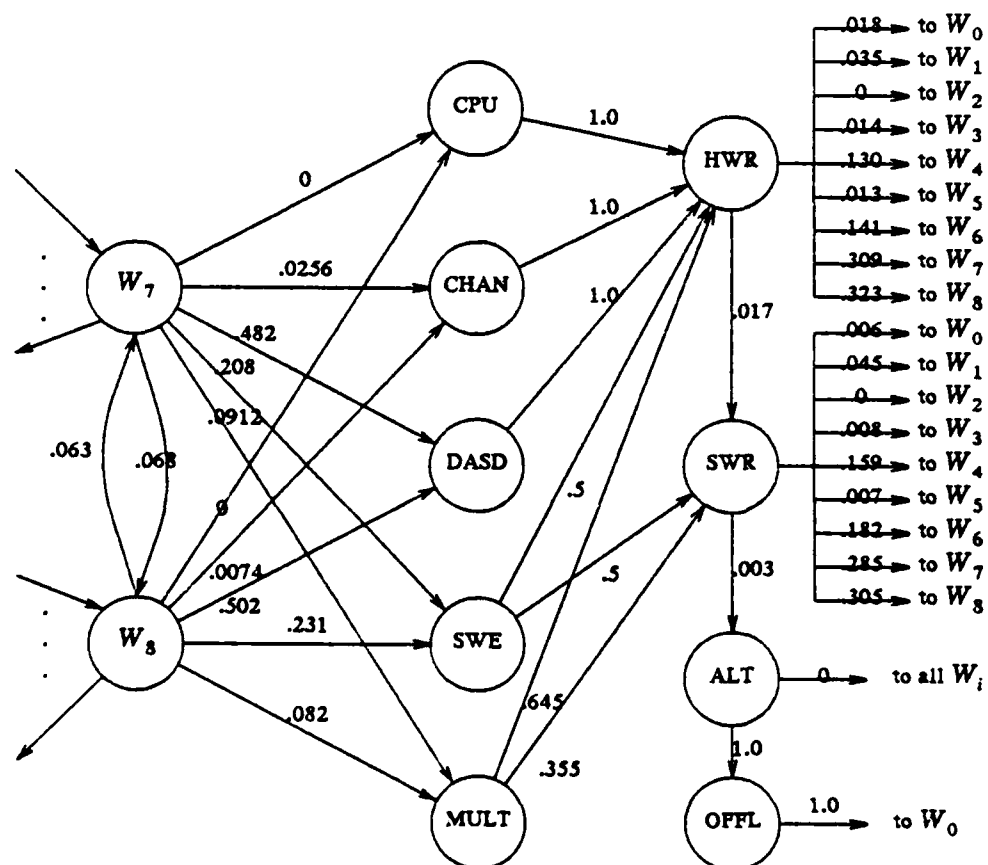

Figure 3. State-transition diagram of resource-usage/error/recovery model

³ Note that the transition probabilities from W_7 to W_8 are different from those in figure 1 where error states were not considered in computing the transition probabilities.

detection, fault isolation and on-line recovery mechanisms allow the measured system to handle an error efficiently and effectively. In less than 1% of the cases is the system not able to recover.

One state which needs further elaboration is the MULT state. Recall that a MULT state denotes a multiple error event affecting more than one component type. Figure 4 shows the state-transition diagram of a MULT error event, i.e., the transition diagram given a MULT error. The model quantifies the interactions between the different components in a multiple error occurrence. From the diagram, it is seen that in about 65% of the cases a multiple error starts as a software error (SWE) and in 32% of the cases it starts as a disk error (DASD). Given that a disk error has occurred, there is nearly a 30% chance that a software error will follow. It is also interesting to note that there is a 64% chance that one software error will be followed by another different software error.

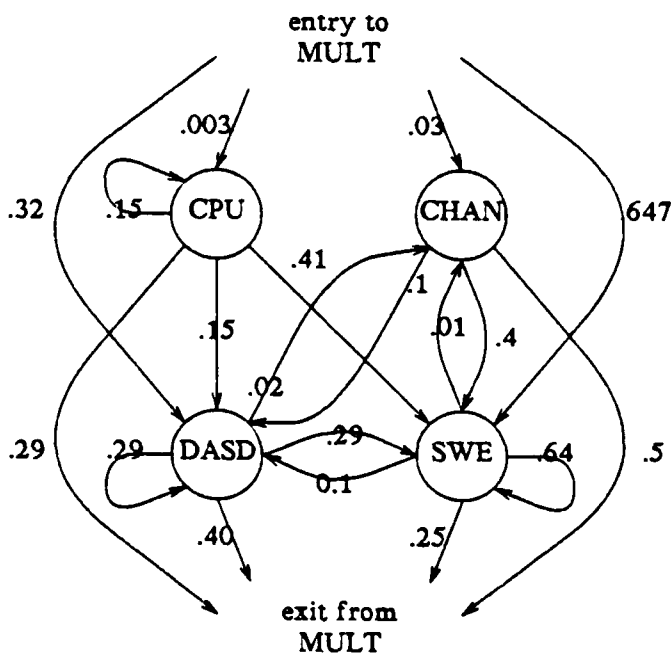

Figure 4. State-transition diagram of a given multiple error (MULT)

4.1. Distributions for Workload and Error States

Table 3 shows the characteristics of both the workload and error states in terms of their waiting times. An examination of the mean and standard deviation of the waiting times indicates that not all waiting times are simple exponentials. This is particularly pronounced for the error states.

Workload			Error		
State	Mean waiting time	Standard deviation	State	Mean waiting time	Standard deviation
W_1	1263.71	1384.20	CPU	*	*
W_2	289.65	1.19	CHAN	5.08	18.31
W_3	698.79	913.30	SWE	41.35	103.35
W_4	1203.05	1130.28	DASD	120.86	223.89
W_5	613.74	421.73	MULT	293.28	262.84
W_6	1380.86	1588.76			
W_7	1071.31	1004.46			
W_8	1612.72	2576.35			

* statistically insignificant

Table 3. Characteristics of waiting time (seconds) in workload and error states

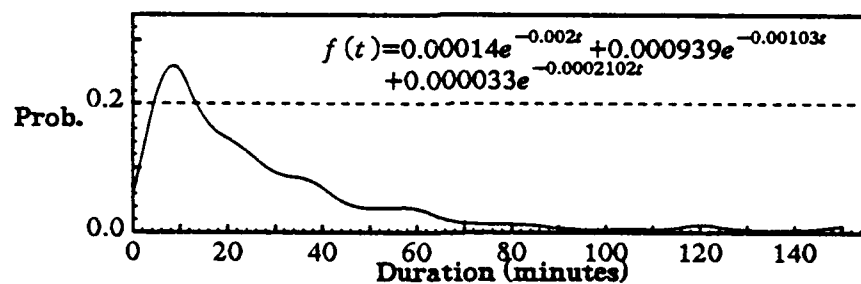

(a). Waiting time density for W_8

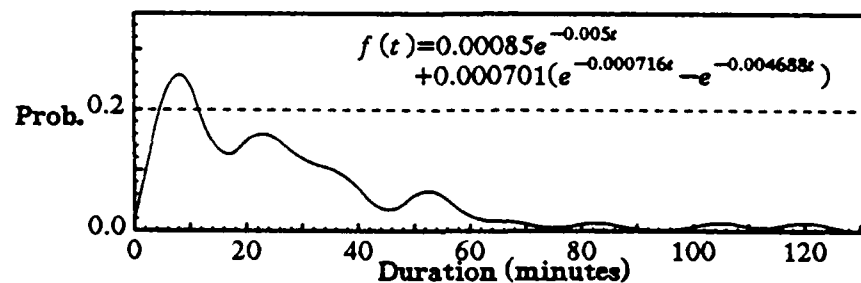

(b). Holding time density from W_8 to SWE state

Figure 5. Waiting and holding time densities

Figure 5(a) and 5(b) shows the densities of waiting time for W_g state and also the specific holding time to the SWE error state. The waiting time for state i is the time that the process spends in state i before making a transition to any other state. The holding time for a transition from state i to state j is the time that the process spends in state i before making a transition to state j [14]. This is the same as the distribution of a one-step transition from state i to j . The distributions in figure 5 are fitted to phase-type exponential density functions [15] and, tested by using the Kolmogorov-Smirnov test at a 0.01 significance level.

4.2. Error Duration Distributions

Recall that an error event can involve more than one error and since errors frequently occur in bursts. During an error burst the system goes into an error \rightarrow recovery cycle until the error condition disappears⁴. In such cases we measure the duration of an error event as the time difference between the first detected error and the last detected error, caused by the same event. The duration of an error event can be used to measure the severity of the error. Since each recovery type takes approximately a constant amount of time, the loss of work can be approximated by the error rate in this period. In section 6, we use this information to build a reward model for the system. Figure 6 shows examples of error duration densities for two different types of errors, SWE and MULT.

In summary, we have developed a state-transition model which describes the normal and error behavior of the system. A key characteristic of the model is that the waiting time in some of the workload states and in most error states cannot be modeled as simple exponentials. Furthermore, the holding times from a given workload state to different error states are dependent on the destinations. Thus, the overall system is modeled as a complex irreducible semi-Markov process.

⁴This is typical of many systems (e.g. see [8]). The final recovery usually occurs because the conditions which triggered the error disappear due to change in system activity.

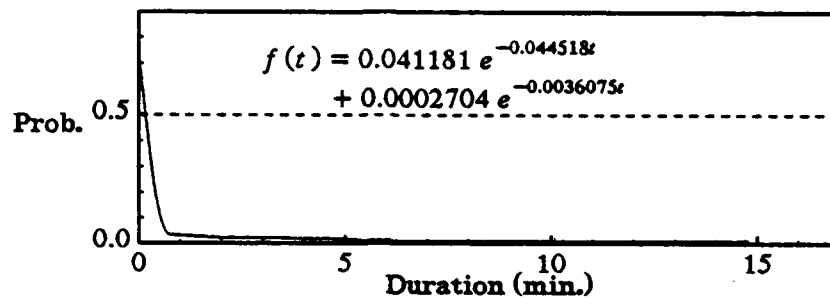

(a). Waiting time density for SWE

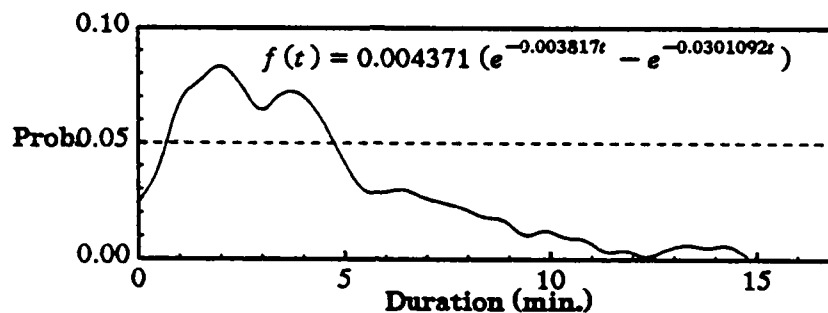

(b). Waiting time density for MULT

Figure 6. Error duration densities

5. Model Behavior Analysis

Now that we have an overall model, we show the usage of this model to predict key system characteristics. The mean time between different types of errors is evaluated along with model characteristics, such as the occupancy probabilities of key normal and error states.

5.1. General Characteristics

By solving the semi-Markov model, we find that the modeled system made a transition every 9 minutes and 8 seconds, on average. In comparing this with the mean time between errors (MTBE) listed in Table 4, it is clear that most often the transitions are from one normal state to another. The table also shows that a DASD error was detected almost every 52 minutes (0.87 hours) while a software error was detected every 1 hour and 45 minutes. Most of the DASD errors (95%) were recovered through hardware recovery (i.e., hardware instruction retry or ECC), thus resulting in negligible overhead. Table 4 also lists the mean recurrence time for recovery states.

Error states					Recovery states			
CPU	CHAN	SWE	DASD	MULT	HWR	SWR	ALT	OFFL
-	26.88	1.75	0.87	4.62	0.62	2.57	-	651.37

Table 4. Mean recurrence time (hours) of error and recovery states

Thus, the on-line hardware recovery routine is invoked once every 0.62 hours, while the software recovery occurs every 2.57 hours. By using an estimated time for each hardware recovery and comparing the results with the recovery overhead, we estimate that the cost of hardware recovery is only 0.02% of total computation time. The mean recurrence time of the alternative recovery routine was not estimated, due to lack of data, i.e., this event seldom occurred.

5.2. Summary Model Probabilities

Since the process is modeled as an irreducible semi-Markov process, we can evaluate the following steady state parameters [14]:

- (1) occupancy probability (Φ_j) - the probability that the process occupies state j .
- (2) conditional entrance probability (π_j) - given that the process is now making a transition, the probability that the transition is to state j
- (3) entrance rate (e_j) - the rate at which the process enters state j at any time instance ($e_j = \frac{\pi_j}{\bar{\tau}}$, where $\bar{\tau}$ is the mean time between transitions)
- (4) mean recurrence time ($\bar{\Theta}_j$) - mean time between successive entries into state j

The model characteristics are summarized in Table 5. A dashed line in this table indicates a negligible value (statistically insignificant). Table 5(a) shows the normal system behavior. For example, given that a transition occurs the system is most likely to go to states W_7 or W_8 . This is also reflected in the respective entrance rates and occupancy probabilities for the mentioned states. From the occupancy probabilities (Φ) we see that almost 34% of the time the CPU load is as high as 0.96 (W_8); 39% of the time the CPU is moderately loaded ($W_6 + W_7$). Table 5(b) shows the error behavior of the system. The table shows that about 30% of the transitions are to an error state (obtained by summing all the π 's for all the error states). The DASD errors have the highest

Measure	Normal state								
	W_0	W_1	W_2	W_3	W_4	W_5	W_6	W_7	W_8
Φ	0	0.0625	0.0008	0.0136	0.1258	0.0054	0.1639	0.2255	0.3398
π	0.0257	0.0264	0.0014	0.0104	0.0559	0.0047	0.0635	0.1125	0.1127
e_m	0.00005	0.00005	-	0.00002	0.0001	0.00001	0.00012	0.00021	0.00021
Θ	5.78	5.62	102.56	14.32	2.65	31.38	2.33	1.32	1.32

(a). Normal states

Measure	Error state					Recovery state			
	CPU	CHAN	SWE	DASD	MULT	HWR	SWR	ALT	OFFL
Φ	-	0.00005	0.0066	0.0383	0.0179	0.00022	0.00011	-	-
π	-	0.0055	0.0850	0.1692	0.0322	0.2379	0.0572	-	0.00023
e_m	-	0.00001	0.00016	0.00032	0.00006	0.00045	0.00011	-	-
Θ	-	26.88	1.75	0.87	4.62	0.62	2.57	-	651.37

(b). Error and recovery states

* sec⁻¹ ** in hours

Table 5. Summary of model characteristics

entrance probability. For the data shown in the table it can be estimated that an error is detected, on the average, every 30 minutes. Of course, over 98% of these errors incur negligible overhead.

An interesting characteristic of the multiple errors is also seen in Table 5(b). Although the entrance probability of a MULT error is lower than that for SWE, its occupancy probability is higher. This is due to the fact that a MULT error event has a longer mean waiting time as compared to SWE error events (293 seconds versus 41 seconds).

5.3. Model Validation

Even though our model is developed from real data, it needs to be validated since the model identification process, e.g., the workload clustering, allow us to only approximate the real system behavior. In order to evaluate the validity of the model, three measures evaluated via the model were compared with direct calculations from the actual data. Table 6 shows the comparison of the occupancy probabilities for key normal states (occupancy probability greater than 0.1) and for one

key error state (DASD).⁵ The table also shows the comparison for the mean recurrence time ($\bar{\Theta}$) of the SWE error event and for its standard deviation (Std). It can be seen that all the predicted values are around 3 percent or less, indicating that the proposed semi-Markov model is an accurate estimator of the real system behavior. This also provides support for the model structure identification method employed in this paper.

5.4. Markov Versus Semi-Markov

This section investigates the significance of using a semi-Markov model to describe the overall resource-usage/error/recovery process. It has been argued that since errors only occur infrequently (i.e., λ is small), a Markov model may well approximate the real behavior. Clearly, if only the first moments, e.g., MTBE, are of interest the Markov model provides adequate information. If the distributions (e.g., the time to error distribution) or higher moments are of interest the Markov model may be inadequate. Thus, although our evidence shows that the semi-Markov process is a better model, i.e., more closely approximates the data from the measured system, it is reasonable to ask what deviations occur if a Markov process is assumed. In order to answer this question we use a Markov model to describe our system and compare the results with those obtained through the more realistic semi-Markov model.

	Φ				DASD	$\bar{\Theta}$	Std
	W_A	W_B	W_C	W_D		SWE	SWE
Model	0.1258	0.1639	0.2255	0.3398	0.0383	1.75	2.18
Actual	0.1259	0.1634	0.2311	0.3452	0.0386	1.72	2.11
ϵ	0.0008	0.0031	0.0242	0.0156	0.0156	0.022	0.033
Actual							

ϵ : the absolute error, | Model - Actual |

Table 6. Comparison of Φ , $\bar{\Theta}$ and standard deviation

⁵ The 'Actual' values are calculated from observed data. For example:

$$\Phi_i = \frac{\text{total time that the system was observed to be in state } i}{\text{length of the observation period}}$$

We compared the two by calculating two steady state parameters. The first is the complementary distribution of the time to error (referred to as $R(t)$) for different error types. The second is the standard deviation of $R(t)$. The results for the SWE state are shown in Table 7. It is clear that the Markov model over estimates the $R(t)$ in the early life (for low time to error probabilities) and under estimates $R(t)$ for high time to error probabilities. The standard deviation is also considerable under estimated by the Markov model thus casting doubts on the validity of using MTBE estimates themselves.

In summary, our measurements show that using a Markov model is optimistic in the short run and pessimistic in the long run. The underestimation of the standard deviation of $R(t)$ is also a serious problem because it calls into question the representativeness of the MTBE estimates.

6. Performability Analysis

In this section we use the workload/error/recovery model to evaluate the performability of the system. Reward functions are used to depict the performance degradation due to errors and also due to different types of recovery procedures. Since the recovery overhead for each recovery state in the modeled system is approximately constant, the total recovery overhead for each error event and thus the reward depends on the error rate during that event. Thus, higher the error rate during an error event, the higher is the recovery overhead and, hence lower the reward. On this basis we define a reward the reward rate, r_i (per unit time) for each state of the model as follows:

	R(t)								Std (mins)
semi-Markov	0.99	0.61	0.44	0.32	0.24	0.18	0.14	0.10	28.63
Markov	1.00	0.71	0.50	0.35	0.25	0.17	0.12	0.09	25.13
Time (mins)	0	7.5	15.0	22.5	30.0	37.5	45.0	52.5	

Table 7. Comparison between Markov and semi-Markov

$$r_i = \begin{cases} \frac{s_i}{s_i + e_i} & \text{if } i \in S_N \cup S_E \\ 0 & \text{if } i \in S_R \end{cases}$$

where, the s_i and e_i are the service rate and the error rate in state i , respectively. Thus one unit of reward is given for each unit of time when the process stays in the good states S_N . The penalty paid depends on the number of errors generated by an error event. With an increasing number of errors the penalty per unit time increases, and accordingly, the reward rate decreases. Zero reward is assigned to recovery states. Based on this proposal, reward rates for the error states are as shown in Table 8.

The reward rate of the modeled system at time t is a random variable $X(t)$, which is defined as

$$X(t) = \begin{cases} 1 & \text{process is in state } i \in S_N \\ r_i & \text{process is in state } i \in S_E \\ 0 & \text{otherwise.} \end{cases}$$

Therefore the expected reward rate $E[X(t)]$ can be evaluated from $E[X(t)] = \sum_i p_i(t) r_i$. The

cumulative reward by time t is $Y(t) = \int_0^t X(\sigma) d\sigma$ and the expected cumulative reward is given by

[16]:

$$E[Y(t)] = E\left[\int_0^t X(\sigma) d\sigma\right] = \sum_i r_i \int_0^t p_i(\sigma) d\sigma.$$

where $p_i(t)$ is the probability of being in state i at time t . In order to evaluate $p_i(t)$ and hence other measures, we convert the semi-Markov process into a Markov process using the method of stages [15,17]. The state probability vector $P^*(t) = (\dots, p_i(t), \dots)$ of the Markov process can be

State	DASD	SWE	CHAN	MULT
r_i	0.5708	0.2736	0.9946	0.2777

Table 8. Reward rates for error states

derived from $P^*(t) = P^*(0) e^{Qt}$, where $P^*(0) = (1.0, \dots, 0)$ and Q is transition rate matrix of the Markov process [14].

In order to study the performance degradation due to different types of errors, the irreducible semi-Markov process was transformed by considering the OFFL (off-line repair) state as the absorbing state. The expected reward calculated with this assumption indeed reflects the true performability until system failure. Next, for evaluating the impact of different error events we first observe that often these events have significant error duration time (e.g., MULT state has an mean error duration of 5 minutes with a standard deviation of 4 minutes). Since the majority of jobs last less than a few minutes, as far as a user program is concerned, an entry into an long duration error state is similar to entering an absorption state with $r_i > 0$. Thus, the impact of the MULT can be evaluated by making it into an absorption state with $r_i > 0$. A similar analysis can be performed for other error states.⁶

In our analysis, we first make the OFFL state the absorbing state. This gives the expected performance until an off-line failure. Then we evaluate three other cases.

- a) OFFL case (OFFL),
- b) MULT and OFFL case (MULT),
- c) SWE, MULT and OFFL case (SWE), and
- d) DASD, MULT and OFFL case (DASD).

Case (a) gives the overall performability of the system assuming that OFFL (off-line repair) is the absorbing state, i.e., the impact of all other error events are taken into account. This gives both the transient and steady state performability of the system. Next we assume in case (b) that both MULT and OFFL are absorbing. The difference between (a) and (b) approximates the expected performance loss due to possible entry into a long duration MULT state. Similarly, the difference between (a) and (c) provides an estimate of loss of performance due to entry into an SWE state. In the long term, of course, each will reach a steady state value. The above analyses were performed

⁶An alternative approach, the performance loss (PL) based on the steady state occupancy probabilities, was suggested by one of the referees. $PL_i = \Phi_i(1-r_i) + \sum_{r \in R} \Phi_{(i,r)}$, where $\Phi_{(i,r)}$ is the probability of visiting a recovery state r after an error state i .

on the resulting Markov reward model of the system using SHARPE (the Symbolic Hierarchical Automated Reliability and Performance Evaluator)⁷ developed at Duke University:

The curves of Figure 7 show the expected reward rate at time t , $E[X(t)]$, for these four cases. The evaluations of the cumulative reward, $E[Y(t)]$, is discussed in [11]. In practical terms the differences provide an estimate of the loss in reward due to various error types assuming that the jobs are initiated when the system is fully operational. As an example, in Figure 7, we find that that the SWE event degrades system effectiveness considerably more than the DASD event. This is because the reward rate of SWE error is lower than DASD error even though the error probability

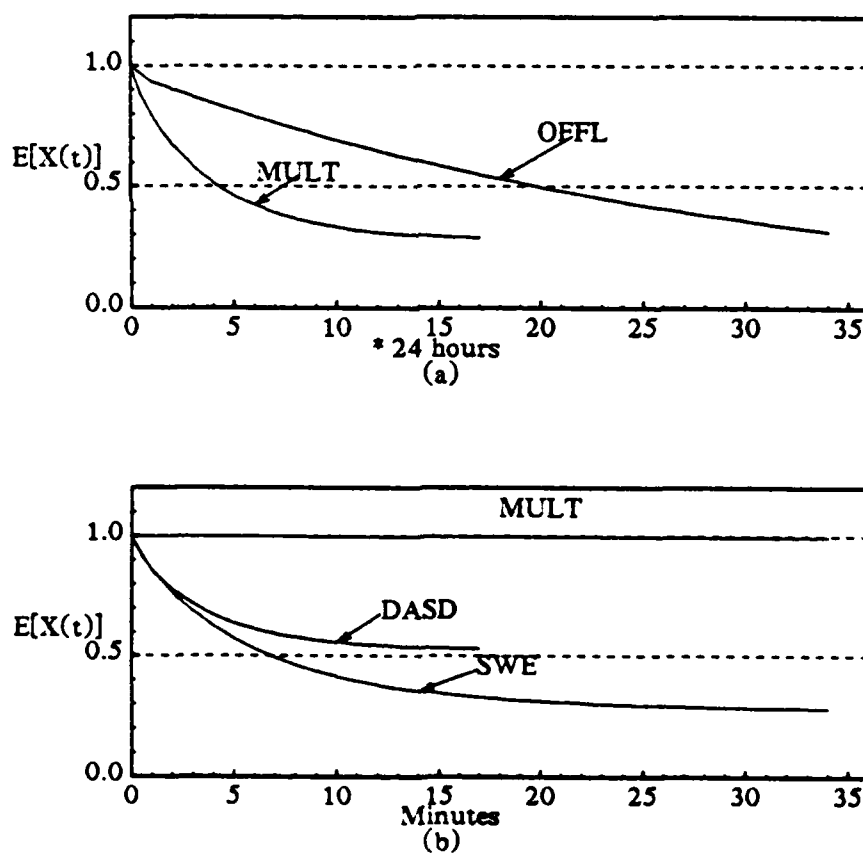

Figure 7. Expected reward rate, $E[X(t)]$

⁷ SHARPE is a modeling tool. It provides several model types ranging from reliability block diagrams to complex semi Markov models [17].

of DASD event is higher than of SWE event.

7. Conclusion

In this study, we have proposed a methodology to construct a model of resource usage, error and recovery in a computer system, using real data from a production system. The semi-Markov model obtained is capable of reflecting both the normal and error behavior of our measured system. The errors are classified into various types, based on the components involved. Both hardware and software errors are considered, and the interaction between the system components (hardware and software) is reflected in a multiple error model. The proposed reward measure allows us to predict the performability of the system based on the service and error rates. It is suggested that other production systems be similarly analyzed so that a body of realistic data on computer error and recovery models is available.

Acknowledgment

The authors would like to thank John Gerardi and the members of Reliability, Availability and Serviceability Group at IBM-Poughkeepsie for access to the data and for their valuable comments and suggestions. Thanks are also due to Dr. W.C. Carter for valuable discussions during the initial phase of this work. We also thank L.T. Young and P. Duba for their careful proofreading of the draft of this manuscript. Finally, we thank the referees for their constructive comments which were extremely valuable in revising the paper.

Reference

- [1] Meyer, J.F., "Closed-Form Solutions of Performability," *IEEE Transactions on Computers*, pp. 648-657, July 1982.
- [2] Geist, R.M., Smotherman, M., Trivedi, K.S., and Bechta Dugan, J., "The Reliability of Life Critical Systems," *Acta Informatica*, vol. 23, pp. 621-642, 1986.
- [3] Goyal, A., Carter, W.C., de Souza e Silva, E., Lavenberg, S.S., and Trivedi, K.S., "The System Availability Estimator," in *Proceedings of the 16th International Symposium on Fault-Tolerant Computing*, Vienna, Austria, July 1986.
- [4] Schoen, O., "On a Class of Integrated Performance/Reliability Models based on Queuing Networks," in *Proceedings of the 16th International Symposium on Fault-Tolerant Computing*, Vienna, Austria, pp. 90-95, July 1-4, 1986.
- [5] Iyer, R.K., Rossetti, D.J., and Hsueh, M.C., "Measurement and Modeling of Computer Reliability as Affected by System Activity," *ACM Transactions on Computer Systems*, vol. 4, no. 3, pp. 214-237, August, 1986.
- [6] Littlewood, B., "Theories of Software Reliability: How good are they and how can they be improved?," *IEEE Transactions on Software Engineering*, vol. SE-6, pp. 489-500, September 1980.
- [7] Hsueh, M.C. and Iyer, R.K., "A Measurement-Based Model of Software Reliability in a Production Environment," in *Proceedings of the 11th Annual International Computer Software & Applications Conference*, Tokyo, Japan, pp. 354-360, October 7-9, 1987.
- [8] Castillo, X., *A Compatible Hardware/Software Reliability Prediction Model*. PhD Thesis, Carnegie-Mellon University, July, 1981.
- [9] Ferrari, D., Serazzi, G., and Zeigner, A., *Measurement and Tuning of Computer Systems*. Englewood Cliffs, NJ: Prentice-Hall, Inc., 1981.
- [10] Spath, H. *Cluster Analysis Algorithms*. West Sussex, England: Ellis Horwood Ltd., 1980.
- [11] Hsueh, M.C., *Measurement-Based Reliability/Performability Models*. Ph.D. Dissertation, Computer Science Department, University of Illinois at Urbana-Champaign, August 1987.
- [12] IBM Corporation, *Environmental Record Editing & Printing Program*. International Business Machines Corporation, 1984.
- [13] Iyer, R.K., Young, L.T., and Sridhar, V., "Recognition of Error Symptoms in Large Systems," in *Proceedings of the 1986 IEEE-ACM Fall Joint Computer Conference*, Dallas, Texas, pp. 797-806, November 2-6, 1986.
- [14] Howard, Ronald A., *Dynamic Probabilistic Systems*. New York: John Wiley & Sons, Inc., 1971.
- [15] Trivedi, K.S., *Probability & Statistics with Reliability, Queuing, and Computer Science Applications*. Englewood Cliffs, N.J.: Prentice-Hall, Inc., 1982.
- [16] Smith, R.M. and Trivedi, K.S., "A Performability Analysis of Two Multiprocessor Systems," in *Proceedings of the 17th International Symposium on Fault-Tolerant Computing*, Pittsburgh, PA, pp. 224-229, July 6-8, 1987.
- [17] Sahner, R.A. and Trivedi, K.S., "Reliability Modeling Using SHARPE," *IEEE Transactions on Reliability*, pp. 186-193, June 1987.

ENVD

DÄTE

3-88

DTIC