

4

DOCUMENT 455-88

OSG

DTIC FILE COPY

TELESCOPE AND LENS ACQUISITION CHECKLIST

AD-A191 309

JANUARY 1988

OPTICAL SYSTEMS GROUP  
RANGE COMMANDERS COUNCIL

WHITE SANDS MISSILE RANGE  
KWAJALEIN ATOLL  
YUMA PROVING GROUND  
ELECTRONIC PROVING GROUND

PACIFIC MISSILE TEST CENTER  
NAVAL WEAPONS CENTER  
ATLANTIC FLEET WEAPONS TRAINING FACILITY  
NAVAL AIR TEST CENTER

EASTERN SPACE AND MISSILE CENTER  
ARMAMENT DIVISION  
WESTERN SPACE AND MISSILE CENTER  
CONSOLIDATED SPACE TEST CENTER  
AIR FORCE FLIGHT TEST CENTER  
AIR FORCE TACTICAL FIGHTER WEAPONS CENTER

DTIC  
ELECTE  
FEB 18 1988  
S D  
H

DISTRIBUTION STATEMENT A: APPROVED FOR PUBLIC RELEASE;  
DISTRIBUTION UNLIMITED.

88 2 16 107

# UNCLASSIFIED

SECURITY CLASSIFICATION OF THIS PAGE

REPORT DOCUMENTATION PAGE				Form Approved OMB No. 0704-0188	
1a. REPORT SECURITY CLASSIFICATION <b>UNCLASSIFIED</b>		1b. RESTRICTIVE MARKINGS			
2a. SECURITY CLASSIFICATION AUTHORITY		3. DISTRIBUTION / AVAILABILITY OF REPORT Approved for Public Release; Distribution Unlimited.			
2b. DECLASSIFICATION / DOWNGRADING SCHEDULE					
4. PERFORMING ORGANIZATION REPORT NUMBER(S) RCC Document 455-88		5. MONITORING ORGANIZATION REPORT NUMBER(S)			
6a. NAME OF PERFORMING ORGANIZATION Optical Systems Group Range Commanders Council		6b. OFFICE SYMBOL (if applicable) STEWS-SA-R	7a. NAME OF MONITORING ORGANIZATION Range Commanders Council		
6c. ADDRESS (City, State, and ZIP Code) White Sands Missile Range, NM 88002		7b. ADDRESS (City, State, and ZIP Code)			
8a. NAME OF FUNDING / SPONSORING ORGANIZATION	8b. OFFICE SYMBOL (if applicable)	9. PROCUREMENT INSTRUMENT IDENTIFICATION NUMBER			
8c. ADDRESS (City, State, and ZIP Code)		10. SOURCE OF FUNDING NUMBERS			
		PROGRAM ELEMENT NO.	PROJECT NO.	TASK NO.	WORK UNIT ACCESSION NO.
11. TITLE (Include Security Classification) TELESCOPE AND LENS ACQUISITION CHECKLIST					
12. PERSONAL AUTHOR(S)					
13a. TYPE OF REPORT Final		13b. TIME COVERED FROM _____ TO _____		14. DATE OF REPORT (Year, Month, Day) January 1988	15. PAGE COUNT 23
16. SUPPLEMENTARY NOTATION New Document					
17. COSATI CODES			18. SUBJECT TERMS (Continue on reverse if necessary and identify by block number)		
FIELD	GROUP	SUB-GROUP	Telescope, lens, flat mirrors, glass, coating specifications, prisms, windows, purchase discription, edge beveling, resolution, focal length, and reticle defects.		
19. ABSTRACT (Continue on reverse if necessary and identify by block number) This checklist provides guidances as an aid for procuring cost sensitive design elements in telescope and lens systems. All ranges which buy telescopes can use this checklist for cost effective procurement, to enhance commonality and for future joint procurement, and exchangeability. Equipment design elements such as telescopes, lens, flat mirrors prisms, glass, coating specifications, and windows are discussed in depth in this document.					
20. DISTRIBUTION / AVAILABILITY OF ABSTRACT <input checked="" type="checkbox"/> UNCLASSIFIED/UNLIMITED <input type="checkbox"/> SAME AS RPT. <input type="checkbox"/> DTIC USERS			21. ABSTRACT SECURITY CLASSIFICATION		
22a. NAME OF RESPONSIBLE INDIVIDUAL Camilla F. McArthur			22b. TELEPHONE (Include Area Code) (505) 678-1107/1108	22c. OFFICE SYMBOL STEWS-SA-R	

DOCUMENT 455-88

TELESCOPE AND LENS ACQUISITION CHECKLIST

JANUARY 1988

Optical Systems Group  
Range Commanders Council

Published by  
Secretariat  
Range Commanders Council  
U.S. Army White Sands Missile Range  
New Mexico 88002

Accession For	
NTIS GRA&I	<input checked="" type="checkbox"/>
DTIC TAB	<input type="checkbox"/>
Unannounced	<input type="checkbox"/>
Justification	
By _____	
Distribution/	
Availability Code	
Dist	Avail and/or Special
A-1	

## FOREWORD

This checklist provides guidances as an aid for procuring cost sensitive design elements in telescope and lens systems. All ranges which buy telescopes can use this checklist for cost effective procurement, to enhance commonality and for future joint procurement and exchangeability.

# TABLE OF CONTENTS

	<u>Page</u>
Foreword.....	iii
1.0 Telescopes.....	1
1.1 Mounting.....	1
1.2 Sealing.....	1
1.3 Handles and Covers.....	1
1.4 Defects.....	1
1.5 Resolution.....	1
1.6 Focusing.....	1
1.7 Focus Range.....	1
1.8 Focal Length.....	1
1.9 Shock and Vibration.....	1
2.0 Lens.....	1
2.1 Mounting.....	1
2.2 Tolerances.....	2
2.3 Plastic Lens.....	2
2.4 Defects.....	2
2.4.1 Edge Chips.....	2
2.4.2 Edge Beveling.....	2
2.4.3 Cemented Interfaces.....	2
2.5 Thickness.....	2
3.0 Flat Mirrors.....	3
3.1 Mounting.....	3
3.2 Defects.....	3
3.3 Thickness.....	3
3.4 Metal Mirrors.....	3
4.0 Prisms.....	3
4.1 Mounting.....	3
4.2 Defects.....	3
4.3 Coating.....	3
4.4 Tolerances.....	3
4.5 Flatness.....	3
4.6 Amici.....	3
5.0 Glass.....	4
5.1 General Properties.....	4
5.2 Special.....	4
5.3 Glass Bank.....	4
6.0 Coating Specification.....	4
7.0 Windows.....	4
7.1 Wedge.....	4
7.2 Reticle Defects.....	4
8.0 Related Information.....	4
References.....	5
 Appendixes	
A. Purchase Description for 100-Inch Objective Lens System.....	A-1
B. Sample Checklist for Lens Specifications.....	B-1

## 1.0 Telescopes

1.1 Mounting: The telescope shall be made for rigidly mounting the lens on the instrument platform of the tracking mount. Give the physical details of the instrumentation platform. Give the desired height of the optical axis above the mounting base of the lens system ( $\pm 0.005$  inches). The rear external surface of the lens system should have a camera adapter plate, threaded or pinned, centered on the optical axis within 0.030 inches.

1.2 Sealing: Seal system for use in humid climates, specifying a positive pressure of 3 to 5 psi with a leakage rate not to exceed 0.1 psi in 24 hours at a constant ambient temperature. This sealing process will require impregnated castings (MIL-M-6869). For a cheaper system, vent the interior through a canister of silica gel and provide a means of changing the canister when it is depleted.

1.3 Handles and Covers: Provide carrying handles and shields or covers for delicate components and adjustment knobs.

1.4 Defects: Tolerance for 5-inch aperture or smaller, scratch 60-80 microns, dig or bubble 40-50 microns, larger than 5 inch, scratch 120-150 microns, dig or bubble 80-100 microns.

1.5 Resolution: The lens should have a minimum resolution with a high-contrast target of 40 lines per millimeter (1-mm) on axis and 35 1-mm off axis. With a low contrast target, the resolution should be 25 1-mm on axis and 15 1-mm off axis.

1.6 Focusing: The defined optical resolution should be maintained throughout the focusing range. The optical axis shift should not exceed 20-arc seconds at the image plane throughout the defined range.

1.7 Focus Range: The shorter the focus range, the cheaper the lens will be. The lens should focus to infinity. The closest focal point depends on the application but, in general, should not be closer than 1,500 to 2,000 feet.

1.8 Focal Length: The manufactured focal length should be within 1 or 2 percent of the specified length and stamped or otherwise permanently marked on the exterior of the lens system.

1.9 Shock and Vibration: The lens system shall withstand vibration of 5 gs at a frequency of 5 Hz for one minute in each of the three orthogonal axis and 3 gs at a frequency of 200 Hz in each axis.

## 2.0 Lens

2.1 Mounting: The mounting tolerances depend on the instrument system to be used and the action of the system lens. Obviously, the looser the tolerance, the cheaper the system will be to manufacture. A good tolerance is 0.005 inch total indicated runout with the system axis. If tighter tolerances are required, it may be beneficial to use an eccentric ring so that the optical axis may shift at will and then

lock in place. For severe vibrational environments, spring loading or mounting using plastic ring and spacers may be advisable.

2.2 Tolerances: The following table outlines the typical optical tolerances:

Typical Optical Tolerances

Category	*Diam.	*Thick.	*Linear	Fringe	Angles	Surface	Cost
Low Cost	.008	.020	.020	Gage	Degrees	100-80	-10%
Commercial	.003	.010	.010	10-3	15 Min.	80-50	- 5%
Precision	.001	.004	.004	5-2	5-10 Min.	60-40	0%
Extra Precision	.0005	.002	.001	2-1/2	Seconds	60-40	+10%

\*Plus or minus inches

2.3 Plastic Lens: Single-element lens presently made of glass and systems of doublets or triplets used for sensing, scanning and detecting applications should consider using plastic lens because they are lightweight and less expensive when bought in quantities. Contact the manufacturer for transmission characteristics and available molds. In general, plastic lens can hold 8 to 10 fringes on spherical or aspherical surfaces. Incorporate flanges, holes and locating flats to simplify the assembly, and reduce the total number of required parts in a system.

2.4 Defects: See MIL-O-13830 for definitions and more details.

	scratch	dig or bubble
Projection lens	40 to 80 microns	20 to 50 microns
Camera lens	40 to 80 microns	20 to 50 microns
Field flatteners	10 to 30 microns	5 to 10 microns
Condensing lens	80 to 120 microns	50 to 80 microns
Microscope obj.	30 to 60 microns	10 to 30 microns
Eyepieces	20 to 60 microns	5 to 40 microns
Demanding laser app.	0 to 10 microns	0 to 10 microns

2.4.1 Edge Chips: Edge chips are allowed outside the clear aperture of the lens where the clear aperture is 90 percent of the lens diameter. Where the mounting shoulder covers the edge of the lens, let the manufacturer know the size of the allowable chips so the lens will not be rejected unnecessarily.

2.4.2 Edge Beveling: Edges meeting at angles of  $135^\circ$  or larger do not need beveling. Otherwise, bevel edges to a width of 0.25 to 0.5 mm at an angle of  $45^\circ \pm 15^\circ$ .

2.4.3 Cemented Interfaces: Cemented interfaces are considered a lens surface, so specified surface quality standards apply.

2.5 Thickness: The edge thickness of positive lens should be at least 0.025 inch for lens under 0.5 inch diameter and 0.050 inch for

larger diameters. The center thickness of negative lens should be at least 10 percent of its diameter and never less than 5 percent. The tolerance of center thickness is  $\pm 0.010$  inch for commercial lens to  $\pm 0.002$  inch for extra-precise lens.

### 3.0 Flat Mirrors

3.1 Mounting: Use springs to provide controlled retaining forces, not screws. Keep the springs directly opposite the support pads, but do not have more than three support pads.

3.2 Defects: Tolerances are scratch 30-80 microns, dig or bubble 30-50 microns.

3.3 Thickness: For glass, the thickness should be 20 percent of the diameter for 1/10 wave flatness and 10 percent of the diameter for 1/4 wave flatness. These should be made thicker depending on the precision and mounting requirements. The thickness of other substrate material should be adjusted according to density and strength. For very large mirrors, lightening holes are required. If extreme reduction in weight is required, alternate materials such as beryllium should be used for the substrate material instead of glass.

3.4 Metal Mirrors: On metal mirrors, the metal is coated with electroless nickel 0.003 to 0.006 inch thick. For higher accuracy, the mirror is then ground and polished as a conventional glass mirror.

### 4.0 Prisms

4.1 Mounting: For precision mounting, a kinematic arrangement of support pads and retaining springs must be used. For a lower cost mount, the use of a machined surface, a single spring or adhesives may be used (MIL-B-60621).

4.2 Defects: Tolerances are scratch 30-80 microns, dig or bubble 10-50 microns.

4.3 Coating: When using total internal reflecting prisms, a coating of silver or aluminum is advisable on the reflecting surface. Although the coatings reduce the reflection 5 to 15 percent, they protect the surface from dirt, grease and oil which will totally destroy the reflection.

4.4 Tolerances: The cost of a prism held to  $\pm 0.25$  mm can be twice the cost of those with larger tolerances. Angular tolerances on prisms increase cost. It is much less expensive to manufacture angles to protractor accuracy of  $\pm 300$ -arc seconds.

4.5 Flatness: The surface flatness of a precision prism should be 1/4 wavelength or better. The surface quality should be 60/40 microns scratch/dig or better, and the sides should be parallel within 0.05 mm. For prisms of general use, the surface flatness can be between 1/4 and 2 wavelengths. The surface quality can be relaxed up to 80/50 microns scratch/dig and the parallelism to 0.20 mm.

4.6 Amici: The roof angle of an Amici prism should be held to 5 seconds of arc or better for acceptable resolution.

## 5.0 Glass

5.1 General Properties: Elastic Modulus (psi):  $10 \times 10^6$  psi; Density: 0.1 lb/cu. in.; Coefficient of Thermal Expansion:  $5.5 \times 10^{-6}$  in/in/ $^{\circ}$ F; Coefficient of friction: 0.18 dry polished surface against steel.

5.2 Special: Use MIL-G-174 and DD-G-451 for the manufacture of glass for special components. Use off-the-shelf components if possible. Fine-annealed glass is required for most prisms, lens and mirrors. Commercial anneal is adequate for condensers and other non-image forming components, but not for laser beam components.

5.3 Glass Bank. The Air Force has an Optical Glass Bank located at Hill AFB, Utah. It contains an assortment of optical glass blanks of varying sizes and qualities from 24-inch diameter by 5-inch thick to 6-inch diameter by 1-inch thick. None of the glass has been ground and polished. To obtain the glass, contact Headquarters Air Force Logistics Command, Attn: AZ, Wright-Patterson AFB, Ohio 45433. AUTOVON: 787-2851.

## 6.0 Coating Specification

Glass for transmission of visual wavelengths should be coated with magnesium fluoride to meet the requirements of MIL-C-675. A cheaper coating may be specified depending on the application. This specification should include the MIL-C-675 requirements for testing the abrasion resistance and the adhesion of the coating. Reflectance should be less than 0.5 percent from 450 to 650 nm. In critical applications, less than 0.2 percent reflection from each surface is desirable. Coating defects are allowed if their size is within the stated scratch and dig tolerance.

## 7.0 Windows

7.1 Wedge: The wedge angle of a window for precision optical work should be less than 1 second of arc or greater than 30 seconds of arc. This angle puts the second surface reflections at the area of interest or far enough away to be out of the area of interest.

7.2 Reticle Defects: Tolerances are scratch 10-15 microns, dig or bubble 1-3 microns.

## 8.0 Related Information

For related information, see appendix A for the Purchase Description for 100-Inch Objective Lens System. A sample checklist of lens specifications is in appendix B.

## REFERENCES

### Specifications:

- MIL-STD-34 Preparation of Drawings for Optical Elements and Optical Systems; General Requirements for
- MIL-HDBK-141 Optical Design
- MIL-STD-150 Photographic Lenses
- MIL-G-174 Glass, Optical
- DD-G-451 Glass, Float or Plate, Sheet, Figured (Flat, for Glazing, Mirrors and Other Uses)
- GG-O-635 Optical Flats
- MIL-C-675 Coating of Glass Optical Elements (Anti-Reflection)
- MIL-STD-1241 Optical Terms and Definitions
- MIL-W-1366 Windows, Optical Sensor
- MIL-M-6869 Impregnants for Aluminum Alloy and Magnesium Alloy Castings
- MIL-E-12397 Eraser, Rubber-Pumice (For Testing Coated Optical Elements)
- MIL-M-13508 Mirrors, Front Surfaced, Aluminized, for Optical Elements
- MIL-O-13830 Optical Components for Fire Control Instruments; General Specification Governing the Manufacture, Assembly and Inspection of.
- MIL-P-16898 Optical Elements; packaging of.
- MIL-C-48497 Coating, Single or Multilayer, Interference: Durability Requirements for
- MIL-A-48611 Adhesive System, Epoxy-Elastomeric, for Glass to Metal
- MIL-B-48612 Bonding with Epoxy-Elastomeric Adhesive System, Glass to Metal
- MIL-F-48616 Filter (Coatings), Infrared Interference: General Specification for
- MIL-B-50772 Bonding of Precision Mirrors (Glass to Metal)

Articles:

- Calvert, Thomas C., 'Specification of Optical Components'.  
SPIE 12th Annual Technical Symposium,  
Aug 1967.
- Hayes, John D., 'Applications for Optics', Machine Design,  
May 23 1968.
- Kosman, Eugene G., 'The Cost Impact of Restrictive Lens  
Tolerances', Optical Spectra, December 1978.

American National Standards Institute Publications:

- ANSI PH3.20-75 Distance Scales for Focusing Camera Lenses
- ANSI PH3.22-79 Determining the Distribution of Illuminance  
over the Field of a Photographic Objective,  
Method for;
- ANSI PH3.29-79 Designating and Measuring Apertures and  
Related Quantities Pertaining to Photographic  
Objectives and Projection Lenses, Methods of;
- ANSI PH3.35-77 Designating and Measuring Focal Lengths and  
Focal Distances of Photographic Lenses,  
Methods of;
- ANSI PH3.57-78 Optical Transfer Function Measurement and  
Reporting, Guide to;
- ANSI PH3.63-74 Determining the Photographic Resolving Power  
of Photographic Lenses, Method for;
- ANSI PH3.601-81 Focal Length Markings of Lenses
- ANSI PH3.609-80 Resolution Test Target for Photographic  
Optics, Dimensions for;
- ANSI PH3.615-80 Veiling Glare of Still-Picture Camera  
Objectives, Method of Testing;
- ANSI PH3.617-80 Appearance Imperfections of Optical Elements  
and Assemblies, Definitions, Methods of  
Testing and Specs for;

APPENDIX A  
Purchase Description  
for  
100-Inch Objective Lens System

PURCHASE DESCRIPTION  
FOR  
100-INCH OBJECTIVE LENS SYSTEM

1. SCOPE

1.1 Scope: This Purchase Description (PD) sets forth the minimum requirements for the design, fabrication, testing, and performance of a 50-inch focal length objective lens system. The lens system shall be designed to mount on the arm of a mobile, servo-driven tracking platform and provide high-quality imagery to either a 70 mm high-speed camera or a shuttered video camera.

2. APPLICABLE DOCUMENTS

2.1 Government documents. Unless otherwise specified, the following specifications, standards, and handbooks form a part of the PD to the extent specified here.

2.1.1 Specifications, standards and handbooks. Unless otherwise specified, the following specifications, standards, and handbooks form a part of the PD to the extent specified here.

SPECIFICATIONS

MIL-C-675A, 22 January 1976: Coating of Glass Optical Elements.

MIL-M-13508C, 19 March 1973: Mirror, Front Surface Aluminized: For Optical Elements.

Federal Standard 595a, 1 March 1956: Colors.

Military Standard 171, 29 February 1980: Finish of Metal and Wood Surfaces.

3. REQUIREMENTS

3.1 Optical. The 100-inch objective system shall consist of a catadioptric lens having the optical performance specified in 3.1.1 to 3.1.7.

3.1.1 Focal length. The equivalent focal length shall be 100 inches  $\pm$  1 percent. The focal length shall be stamped on the exterior surface of the lens system.

3.1.2 Transmission. The lens T number shall be T-11 or numerically less. The T number shall be stamped on the exterior surface of the lens system.

3.1.3 Wavefront. The lens shall bring a plane incident wavefront to a focus in such a way that, across a 60 mm field, the emergent wavefront in the exit pupil shall conform to the best-fitting sphere with the following tolerances:

a. The root-mean square wavefront deformation shall not exceed one-eighth wavelength of light of the mercury e-line (5461 Å).

b. The peak to valley wavefront distortion shall not exceed one-half wavelength of light of the mercury e-line over at least 90 percent of the area of the clear aperture.

c. On the optical axis, the nonrotationally-symmetrical aberrations shall not exceed one-quarter wavelength of light of the mercury e-line.

3.1.4 Resolution. The lens shall have the minimum resolution specified in table 1 as determined photographically at the film plane, both radially and tangentially, recorded on Eastman Linagraph Shellburst film processed to a gamma of 2-inch Eastman D-19 developer. The specified high-contrast resolution shall be obtained using using a 1000:1 contrast, 1951 Air Force Resolution Target. The specified low-contrast resolution shall be obtained using using a 1.6:1 contrast, 1951 Air Force Resolution Target. The specified off-axis resolution shall be obtained at all points within the 60 mm field of view. The low-contrast resolution shall not be degraded by more the 9 percent because of veiling glare. The targets shall be illuminated by a tungsten source having a color temperature between 2800 and 3200 °K. All the photographic tests shall be made with a Photosonics 10 R camera at a frame rate of 180 per second with the camera and the lens system mounted on a common base. The camera and film for the tests will be furnished by the government.

TABLE 1 Minimum Photographic Resolution in Lines per Millimeter

High Contrast Target	Resolution (lines per mm)
On Axis	40
Off Axis	35
Low Contrast Target	
On Axis	25
Off Axis	15

3.1.5 Veiling glare. Veiling glare shall be no greater than five percent.

3.1.6 Image format. The lens shall furnish, at the image plane, a corrected field-of-view of at least 60 mm diameter. The clear field-of-view shall be at least 70 mm in diameter.

3.1.7 Focal plane position. The distance between the back surface of the lens systems and the focal plane (flange-to-focal plane distance) shall be  $6 \pm 0.5$  inches with the focusing system set in the infinity stop position.

3.2 Thermal stability. When the lens is subjected to temperature changes within the limits specified in 3.9.1, the requirements of 3.1 shall be met, and the total range of variation of focal position shall not exceed 0.1 mm.

3.3 Focusing system. The lens shall incorporate a continuously variable internal focusing system. It shall operate both in a motor-driven and manual mode. Optical resolutions of 3.1.4 shall be maintained throughout the focusing range. Optical axis shift shall not exceed 20-arc seconds at the image plane throughout the range of 3.3.1.

3.3.1 Focus range. The focus range shall be from 500 yards, or closer, to infinity.

3.3.2 Focus rate. The focusing system, using the motor drive, shall have sufficient speed to maintain lens focus on targets having a range rate of 600 m/s at a range of 1 km.

3.3.3 Motor drive. The focusing system shall use a dc motor requiring a  $\pm 12$  volt power supply.

3.3.4 Focus position transducer. A linear motion, infinite resolution potentiometer, shall be incorporated into the focusing system for the purpose of determining the focus setting. Linearity shall be accurate to  $\pm 0.025$  percent. The power rating of the potentiometer shall be at least 1 watt.

3.3.5 Connector. Electrical connection shall be made to the motor and transducer by means of a weatherproof, screw-on connector mounted on the external surface of the lens system.

3.3.6 Manual focus. The lens shall be provided with a continuously variable manual focus control which shall be located sufficiently near the rear of the lens to permit simultaneous manual focusing and visual observation of the focal plane. The focus position transducer of 3.3.4 shall remain engaged, and usable, during manual focus. Manual focus shall be by means of a knurled knob connected by mechanical linkage to the focus assembly. Electrical power shall not be required for manual focus.

3.4 Coatings. The coatings of all optical surfaces shall conform to the applicable sections of MIL-C-675A. Coating of Glass Optical

Elements, and MIL-M-13508C, Mirror, Front Surface Aluminized: For Optical Elements.

3.5 Environmental protection. The lens shall be completely sealed against dust and moisture. A dehumidifier shall be installed to furnish positive condensation protection within the environmental limits specified in 3.9.

3.5.1 Lens caps. Dust covers shall be furnished for the front and rear of the lens.

3.6 Length and weight. The lens shall not exceed 40 inches in length. The maximum weight shall be 125 pounds.

3.7 Mounting. Provision shall be made for rigidly mounting the lens on the instrument platform of the tracking mount. Details of the instrumentation platform are shown in figure 1. The lens mounting shall be such that the optic axis is  $10 \pm 0.005$  inches above the mounting base of the lens system.

3.8 Camera Adapter Interface. The rear, external surface of the lens system shall have a threaded circular hole, centered on the optic axis to within  $\pm 0.030$  inches. The threaded hole shall be dimensioned to mate with the Camera Adapter Ring shown in figure 2.

3.9 Environment.

3.9.1 Operational. The lens shall perform as specified here under all possible combinations of the following environmental conditions:

- a. Ambient air temperatures between 10 and 120 °F.
- b. Altitudes between sea level and 10,000 feet above sea level.
- c. Relative humidity between 5 and 95 percent.
- d. Winds between 0 and 40 miles per hour.
- e. Direct solar radiation of 0.5 kw per square meter for 4-hour periods of time.

3.9.2 Storage. The lens shall perform as specified herein after being subjected to the following environmental conditions:

- a. Ambient air temperatures between -10 and 120 °F.
- b. Relative humidity between 5 and 95 percent and any combination of temperature and humidity that results in condensation.
- c. Shock and vibration of 5 gs at a frequency of 5 Hz for 1 minute in each of the three orthogonal axes and 3 gs at a frequency of 200 Hz in each axis.

3.10 Reliability. The lens system reliability shall be demonstrated during the system test set forth in 4.

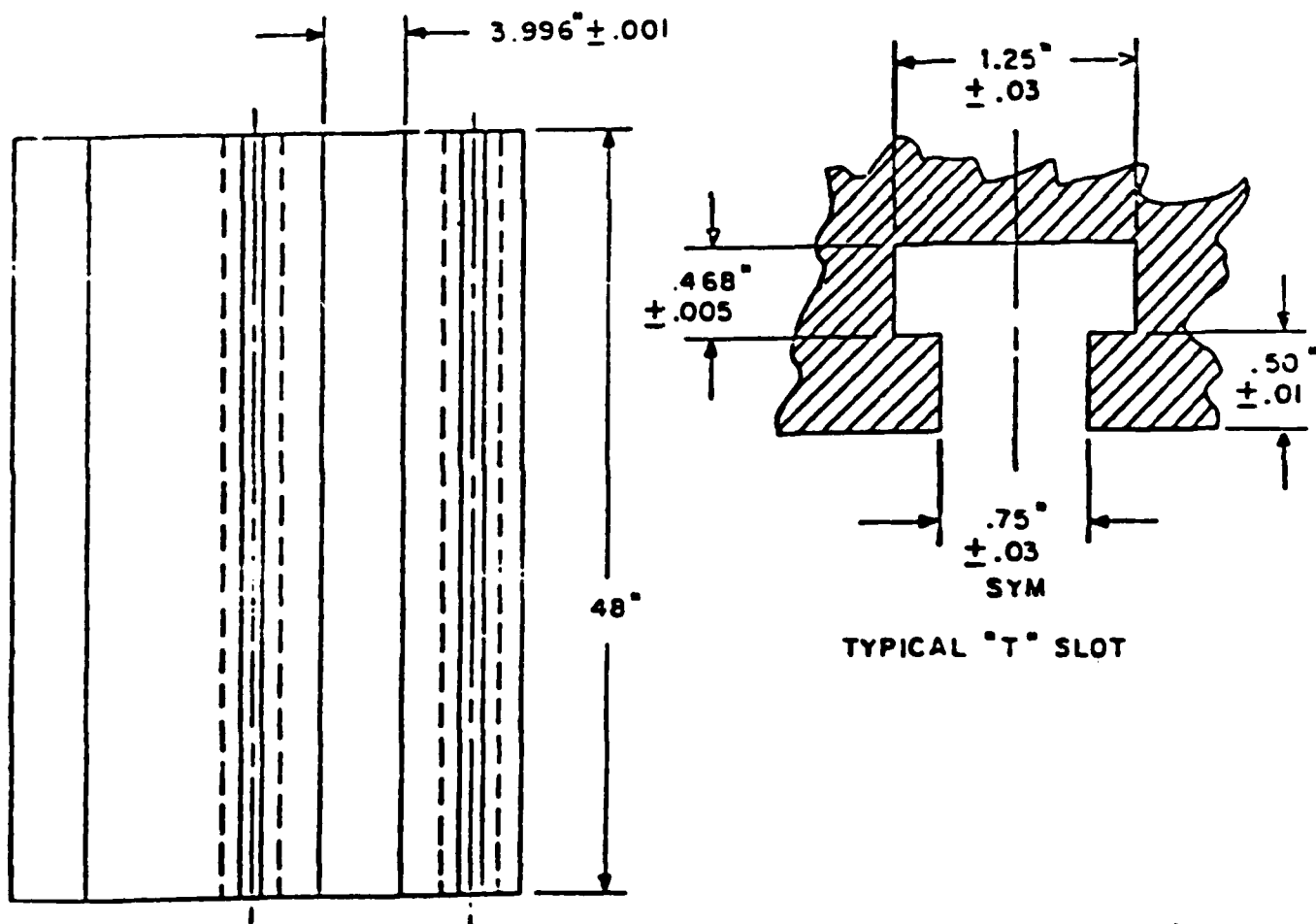
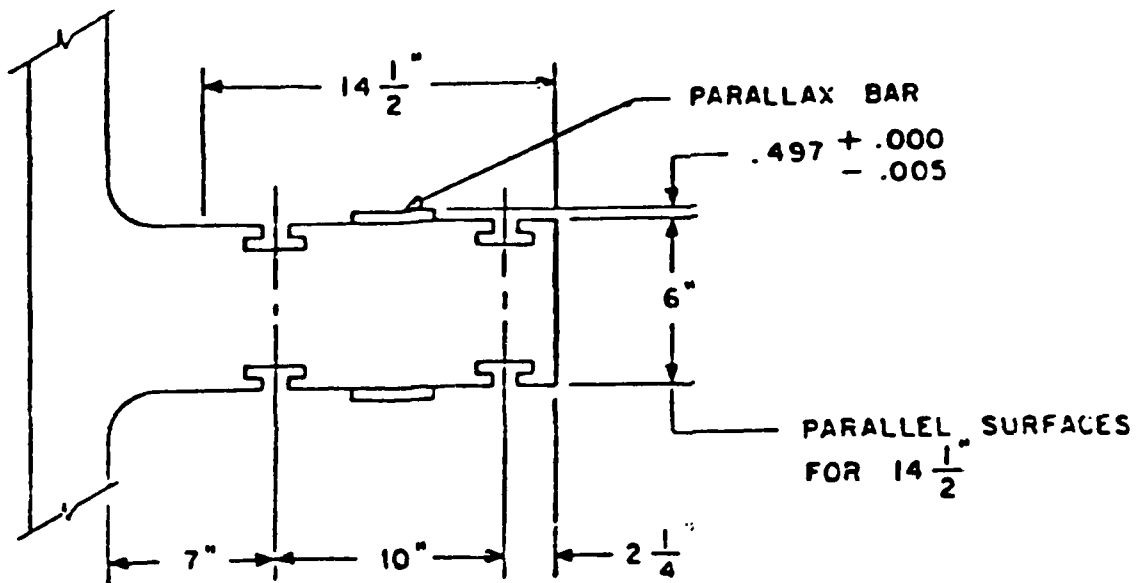

Figure 1. Instrument Mounting Platform (Scale: None)

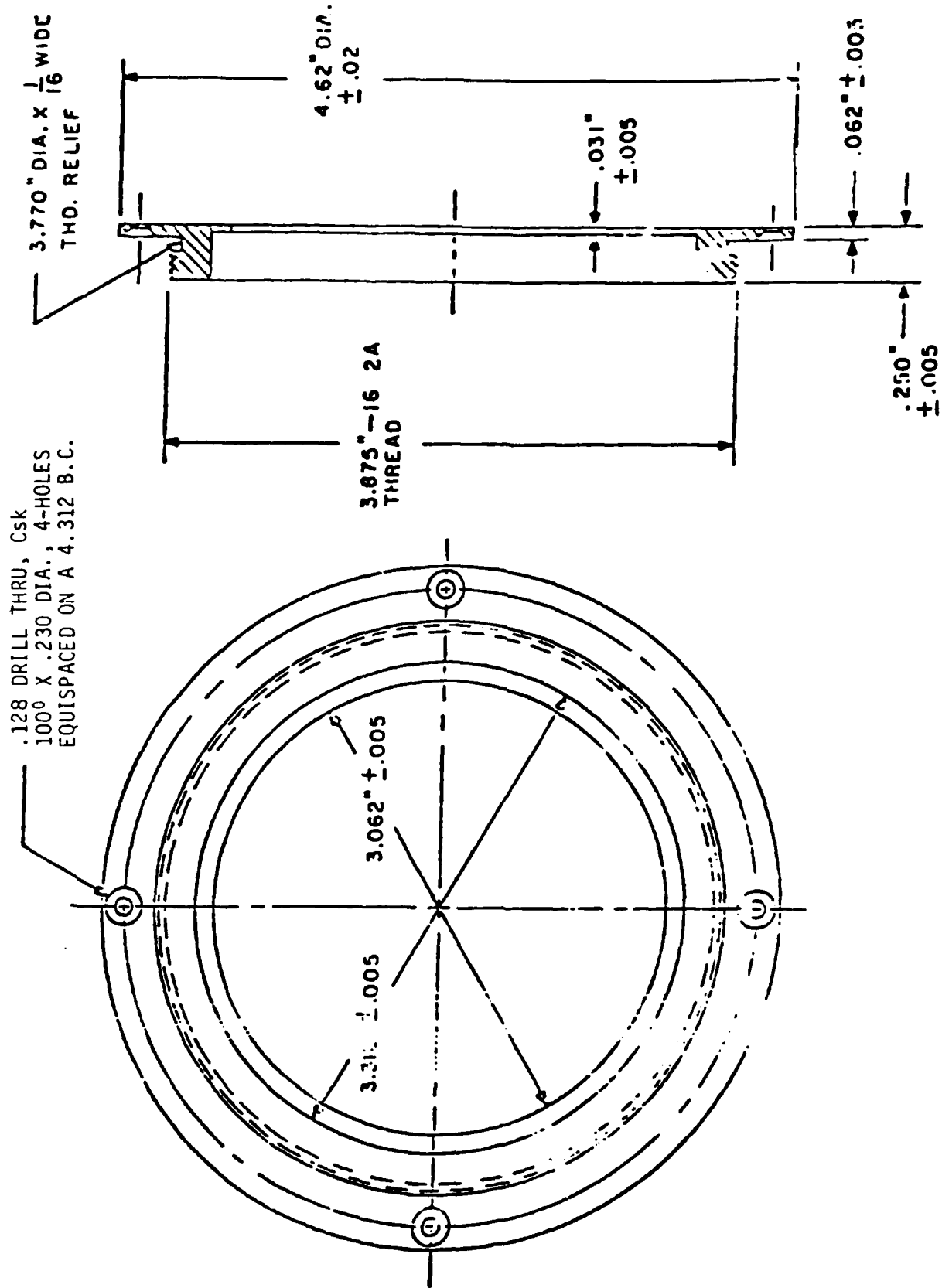

Figure 2. Camera Adapter Ring (Scale: None, Material: ALUM)

3.11 Materials, workmanship, and finishing. The lens system shall have a uniform appearance in color, type of finish, hardware, and trim. External surfaces of the lens be painted with color 17875 (white), as described in Federal Standard 595a. The paint shall be applied according to procedure 22.2 of Military Standard 171.

3.12 Technical data. Technical data shall be furnished as set forth in the Contract Data Requirements List (DD Form 1423) and in accordance with the specification of Data Item Description (DD Form 1664), attached thereto.

#### 4. QUALITY ASSURANCE PROVISIONS

4.1 General. The Quality Assurance requirements of the PD shall be met by compliance with the inspection article of the Contract.

4.2 Reliability testing. The contractor shall demonstrate the reliability of the system in accordance with the following conditions and procedures.

4.2.1 Reliability. The contractor shall demonstrate that the lens system meets the specifications set forth in 3.1 both before and after being subjected to the environmental conditions of 3.9.2.

4.2.2 In-plant acceptance tests. The tests shall be performed at the contractor's plant in the presence of a government witness. The contractor shall make provisions for subjecting the lens to shock, vibration, and temperature variations to demonstrate the compliance with 3.2 and 3.9. The focusing system shall be demonstrated.

#### 5. PACKAGING

5.1 Packaging requirements. Preservation, packaging, packing, marking and shipping shall be as set forth in other contract documents.

#### 6. NOTES

6.1 Intended use. The 100-inch Objective Lens System is intended for use at an inland test range as part of a system for obtaining engineering, event, and trajectory data from aircraft and missile targets. It will primarily be installed on a mobile tracking mount which will be towed over improved (unpaved, gravel) roads.

6.2 Government-furnished equipment. The Photosonics 10R camera and film required by 3.1.4 will be furnished by the government no later than two weeks before the start of the tests of 4.2.2.

**APPENDIX B**

**Sample Checklist for Lens Specifications**

(SAMPLE CHECKLIST)  
LENS SPECIFICATIONS FOR -----

Design: catadioptric or -----

Aperture: minimum \_\_\_\_ mm (\_\_\_\_"), maximum \_\_\_\_ mm (\_\_\_\_")

Focal Length: -----

Focus rate shall be \_\_\_\_ seconds or less from \_\_\_\_ feet to infinity.

Resolution: \_\_\_\_ arc seconds

Diffraction Limited Field: \_\_\_\_ mm or more

Boresight Retention: \_\_\_\_ arc seconds or less over the temperature range of \_\_\_\_ to \_\_\_\_ degrees Centigrade, repeatable to less than \_\_\_\_ arc seconds.

Surface accuracy and quality of lens and mirrors: accuracy of one-tenth wavelength over 90 percent of the diameter. Scratch and dig 60-40.

Primary Mirror: Material with coefficient of linear thermal expansion of  $0.05 \times 10^{-6}/C$ , coated with enhanced aluminum.

Lens: material shall be -----, of sufficient quality to limit coma, astigmatism, and spherical aberration to one-fourth wavelength at the image plane. Antireflection coating of magnesium fluoride.

Light Level Control: provide an auto-iris system or neutral density filter system with attenuation of 0 to 10 dB.

Feedback Potentiometer: provide remote focusing capability. System shall have total resistance of 10,000 ohms, with a linearity of 0.25 percent across the full length of focal element travel.

Additional Features: Air purged system. Focusing shall be accomplished without movement of the attached camera. Projected

illuminated reticle of variable intensity, marked of in 10-arc second intervals.

Construction: Ruggedized to withstand shock loads of 10 gs, rain and dust proof. C mount attachment. Material shall have a coefficient of thermal expansion of less than  $2 \times 10^{-6}/C$ . Wiring shall be as specified in attached wiring diagram. Suggested outline dimensions are given in the attached sketch. Maximum dimensions shall be length - \_\_\_\_\_", height - \_\_\_\_\_", weight - \_\_\_\_\_ lb. Entire system shall be made to fit within a cylinder approximately \_\_\_\_\_" long and \_\_\_\_\_" in diameter. Base plate shall be as shown in the attached drawing.

System MTF: shall be at least \_\_\_\_\_ at \_\_\_\_\_ lp/mm, \_\_\_\_\_ at lp/mm, and \_\_\_\_\_ at \_\_\_\_\_ lp/mm, with measurements made using a monochromatic light source of 6328 angstroms. Cutoff frequency shall be at least \_\_\_\_\_ lp/mm.

Lens delivery schedule:

System transmission: shall be \_\_\_\_\_ or greater.

END

DATE

FILMED

5-88

DTIC