

AD-A192 278

FLASH PHOTOLYSIS OF AROMATIC DIISOCYANATE BASED  
POLYURETHANES(U) UNIVERSITY OF SOUTHERN MISSISSIPPI  
HATTIESBURG DEPT OF POLYMER SCIENCE C E HOYLE ET AL.

1/1

UNCLASSIFIED

10 MAR 88 TR-14 N00014-85-K-8748

F/G 7/5

NL

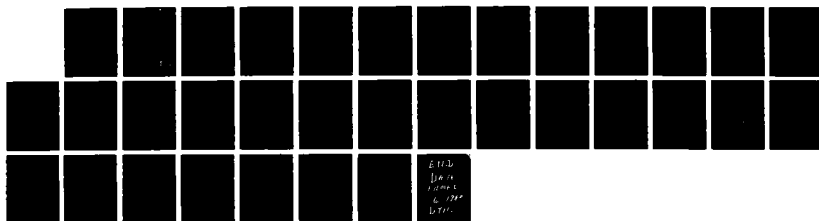

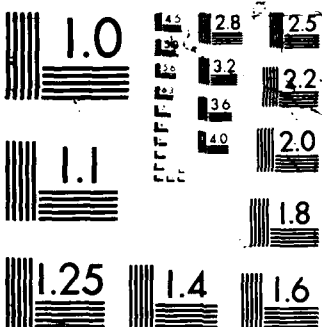

DTIC FILE COPY

4

AD-A192 278

OFFICE OF NAVAL RESEARCH

Contract N00014-85-K-0748

Technical Report No. 14

FLASH PHOTOLYSIS OF AROMATIC DIISOCYANATE BASED POLYURETHANES

by

C. E. Hoyle and Y. G. No

Accepted for Publication as a Chapter in ACS Symposium  
Series Book on US-Australian Workshop on  
Radiation Effects in Polymer Systems

Department of Polymer Science  
University of Southern Mississippi  
Hattiesburg, MS 39406

Reproduction in whole or in part is permitted for any purpose of  
the United States government.

This document has been approved for public release and sale; its  
distribution is unlimited.

DTIC  
ELECTE  
MAR 17 1988  
S D  
SH

88 3 15 021

## REPORT DOCUMENTATION PAGE

1a. REPORT SECURITY CLASSIFICATION NONE		1b. RESTRICTIVE MARKINGS NONE	
2a. SECURITY CLASSIFICATION AUTHORITY NONE		3. DISTRIBUTION / AVAILABILITY OF REPORT  UNLIMITED	
2b. DECLASSIFICATION / DOWNGRADING SCHEDULE NONE		5. MONITORING ORGANIZATION REPORT NUMBER(S) ONR N00014-85-K-0748	
4. PERFORMING ORGANIZATION REPORT NUMBER(S) ONR # 14		7a. NAME OF MONITORING ORGANIZATION Office of Naval Research	
6a. NAME OF PERFORMING ORGANIZATION University of Southern Mississippi	6b. OFFICE SYMBOL (If applicable)	7b. ADDRESS (City, State, and ZIP Code) 800 North Quincy Avenue Arlington, VA 22217	
6c. ADDRESS (City, State, and ZIP Code) University of Southern Mississippi Polymer Science Department Southern Station Box 10076 Hattiesburg, MS 39406-0076		9. PROCUREMENT INSTRUMENT IDENTIFICATION NUMBER	
8a. NAME OF FUNDING / SPONSORING ORGANIZATION Office of Naval Research	8b. OFFICE SYMBOL (If applicable)	10. SOURCE OF FUNDING NUMBERS	
8c. ADDRESS (City, State, and ZIP Code) 800 N. Quincy Avenue Arlington, VA 22217		PROGRAM ELEMENT NO.	PROJECT NO.
		TASK NO.	WORK UNIT ACCESSION NO.
11. TITLE (Include Security Classification)  Flash Photolysis of Aromatic Diisocyanate Based Polyurethanes			
12. PERSONAL AUTHOR(S) C. E. Hoyle and Y. G. No			
13a. TYPE OF REPORT Technical	13b. TIME COVERED FROM _____ TO _____	14. DATE OF REPORT (Year, Month, Day) 3/10/88	15. PAGE COUNT
16. SUPPLEMENTARY NOTATION Accepted as a Chapter in ACS Symposium Series Book based on US-Australia Workshop on Radiation Effects in Polymer Systems.			
17. COSATI CODES		18. SUBJECT TERMS (Continue on reverse if necessary and identify by block number)	
FIELD	GROUP	SUB-GROUP	
19. ABSTRACT (Continue on reverse if necessary and identify by block number)  The laser flash photolysis of aromatic diisocyanate based polyurethanes in solution provides evidence for a dual mechanism for photodegradation. One of the processes, an N-C bond cleavage, is common to both TDI (toluene diisocyanate) and MDI (methylene 4,4'-diphenyldiisocyanate) based polyurethanes. The second process, exclusive to MDI based polyurethanes, involves formation of a substituted diphenylmethyl radical. The diphenylmethyl radical, which readily reacts with oxygen, is generated either by direct excitation (248 nm) or by reaction with a tert-butoxy radical produced upon excitation of tert-butyl peroxide at 351 nm.			
20. DISTRIBUTION / AVAILABILITY OF ABSTRACT <input checked="" type="checkbox"/> UNCLASSIFIED/UNLIMITED <input checked="" type="checkbox"/> SAME AS RPT. <input type="checkbox"/> DTIC USERS		21. ABSTRACT SECURITY CLASSIFICATION	
22a. NAME OF RESPONSIBLE INDIVIDUAL Charles E. Hoyle		22b. TELEPHONE (Include Area Code) (601)266-4868	22c. OFFICE SYMBOL

**FLASH PHOTOLYSIS OF AROMATIC  
DIISOCYANATE BASED POLYURETHANES**

by

Charles E. Hoyle and Young G. No  
Department of Polymer Science  
University of Southern Mississippi  
Southern Station Box 10076  
Hattiesburg, MS 39406-0076

~~88 3 15 010~~

## INTRODUCTION

The photochemical processes responsible for the ultimate degradation and destructive failure of polyurethanes based on aromatic diisocyanates have been investigated extensively for the past twenty-five years by a large number of research groups (1-7). Schemes I and II summarize proposed pathways for photodegradation of polyurethanes based on toluene diisocyanate (mixture of 2,4-TDI and 2,6-TDI isomers) and methylene 4,4'-diphenyldiisocyanate (MDI). Scheme I for TDI based polyurethanes (exemplified by the 2,4 isomer) depicts a traditional photo-Fries type arrangement (4). Scheme II, however, shows a dual mechanism for photodegradation of MDI based polyurethanes recently proposed by Gardette and Lemaire (7), i.e., the traditional photoinduced bond N-C cleavage and subsequent reactions as well as a path for formation of hydrogen peroxide on the central methylene carbon of the bisarylcarbamate moiety with the presumption of further reaction to quinoid type products.

In order to characterize the intermediates leading to the photo-Fries/cleavage and hydroperoxide products shown in Schemes I and II, laser flash photolysis measurements of solutions of both MDI and TDI based polyurethanes were conducted. The results from this study are interpreted by comparison with transient spectra of an aryl monocarbamate and the bispropyl carbamate of MDI. In addition, a dimethylsilicon analog of the MDI bispropyl carbamate is used to confirm the mechanism leading to hydroperoxide formation. The transient spectral analysis in this paper supports anilinyl/carboxyl radical formation by N-C bond

For	<input checked="" type="checkbox"/>
	<input type="checkbox"/>
	<input type="checkbox"/>
on/	
Availability Codes	

Dist	Avail and/or Special
A-1	

DTIC  
COPY  
INSPECTED  
1

cleavage. In addition, evidence is presented for diphenyl methyl radical formation in MDI based carbamates.

**SCHEME I**

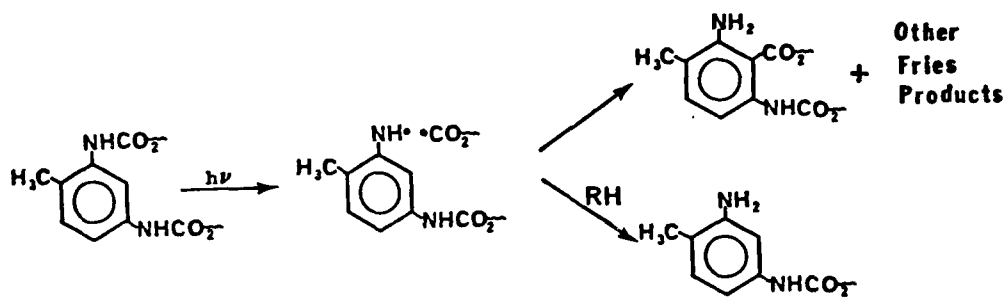

**SCHEME II**

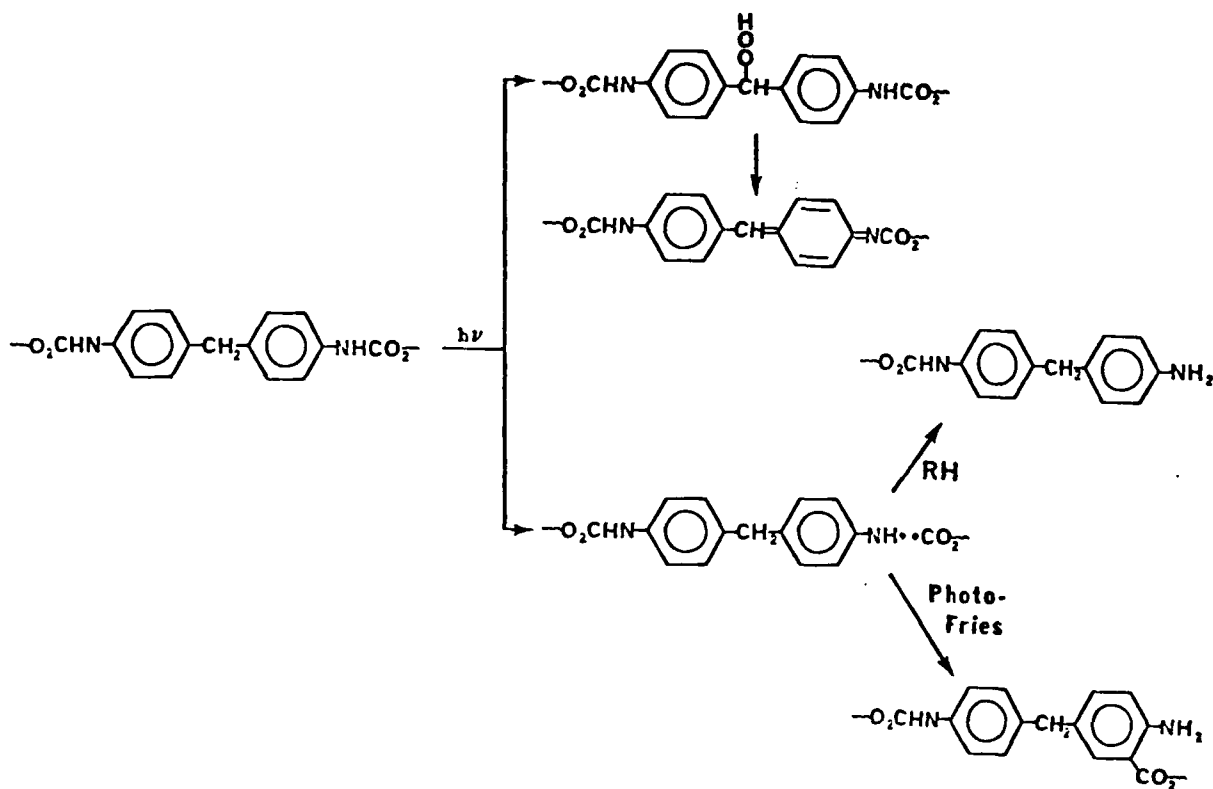

## EXPERIMENTAL

### Materials

Methylene 4,4'-diphenyldiisocyanate (MDI, Mobay) was recrystallized from cyclohexane. Toluenediisocyanate (TDI-- represents mixture of 2,4- and 2,6-isomers in 80/20 ratio) p-toluidine (Aldrich) and aniline (Aldrich) were purified by vacuum distillation before use. Diphenylmethane, tert-butyl peroxide (TBP), 4-bromaniline, butyl lithium in hexane, and ethyl chloroformate, were obtained from Aldrich and used as received. Spectrograde tetrahydrofuran (THF and benzene from Burdick and Jackson were used as received. Poly(tetramethylene ether glycol) with MW 1000 was obtained from polysciences and dehydrated under a rough vacuum at 50° C for 24 h.

Preparation of model compounds and polyurethanes. A procedure for the preparation of the non-silicon containing monocarbamate and biscarbamate models has been reported previously (8). In order to obtain the silicon containing model compound, 5.0 g of bis(4-aminophenyl) dimethyl silane [synthesized according to Pratt, et.al (9)] was added to 7.0 g ethyl chloroformate at room temperature and a salt immediately formed. The mixture was refluxed for 15 min. The solution was then cooled, vacuum filtered, and recrystallized from ethanol to yield 1.0 g of a white powder: MP 162-3° C; Anal.  $C_{20}H_{26}O_4N_2Si$  Calc. C, 62.17; H, 6.70; N, 7.23; Foind C, 62.01; H, 6.79; N, 7.42.

Both of the simple polyurethanes (TDI-PU and MDI-PU) were synthesized according to a well known solution polymerization

technique (10). The polyurethane elastomer (MDI-PUE) was prepared by a pre-polymer method (11).

### Instrumentation

The laser flash photolysis unit consists of a Lumonics 861 Excimer Laser photolysis source, an Applied Photophysics Xenon lamp/monochromator/PMT/auto-offset probe, a Tektronix 7912 transient digitizer, a micro-PDP II computer from Digital Equipment Corporation, and an Applied Photophysics control unit. The laser was operated in the charge on demand mode and the Xenon lamp source (right-angle arrangement) was momentarily pulsed to achieve a high intensity which was flat for about 200  $\mu$ s. The laser was operated at either 248 nm (KrF) or 351 nm (XeF). Nominal outputs were 80 mJ/pulse at 248 nm and 60 mJ/pulse at 351 nm. UV absorption spectra of transient intermediates were constructed point-by-point from decay plots taken at specified wavelength intervals. For the kinetic decay studies, the data were analyzed using a software package from Applied Photophysics.

## RESULTS AND DISCUSSION

In order to demonstrate the use of laser flash photolysis in elucidation of the MDI based polyurethane photolysis mechanism three polyurethanes, two aryl biscarbamate models, an aryl monocarbamate model, and an aromatic amine were selected. Two of the polyurethanes are based on MDI while the third is based on TDI (mixture of 2,4 and 2,6 isomers in 80/20 ratio). The MDI based polyurethanes all have the same basic carbamate repeat unit. The MDI elastomer (MDI-PUE) is soluble in tetrahydrofuran (THF). The simple polyurethane (MDI-PU) based on MDI and 1,4-butanediol is used in the t-butoxy abstraction reactions since it does not contain a polyether backbone.

The results and discussion section is divided into two parts. The first part deals with direct laser flash photolysis of the MDI-PUE polymer and appropriate small molecule models. The transient spectra generated by direct excitation of the polyurethane are interpreted by consideration of the primary photochemical reactions of the carbamate moiety. The second part describes results obtained by production of a radical transient species which is capable of abstracting labile hydrogens from the polyurethane. This latter procedure represents an alternative method for production of the transient species which were obtained by direct excitation.

Laser-Flash Photolysis of TDI-PU, MDI-PUE, and Model Compounds at 248 nm. Figures 1 and 2 show the transient absorption spectra of TDI-PU ( $2.3 \times 10^{-3}$  g/dL) and MDI-PUE ( $5.5 \times 10^{-3}$  g/dL) in THF at

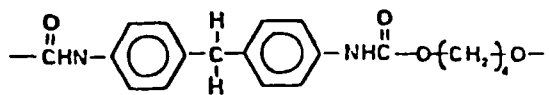

MDI-PU

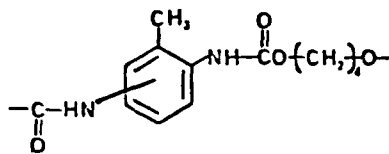

TDI-PU

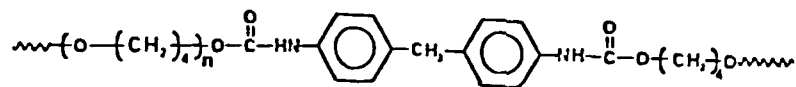

MDI-PUE

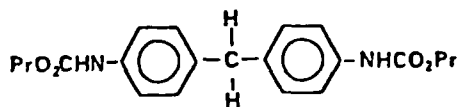

BP-MDI

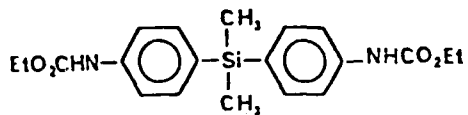

SiMe<sub>2</sub>-MDI

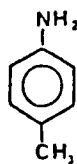

p-Toluidine

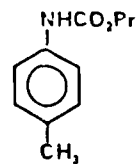

Propyl N-tolylcarbate

a 2.0  $\mu$ s delay after pulsing with a krypton fluoride excimer laser ( $\lambda_{ex}=248$  nm) in air and nitrogen saturated samples. Both spectra have common peaks in nitrogen saturated solutions (shown by arrows) at 310 nm, 340-360 nm (broad), and above 400 nm (broad, diffuse absorbance). The MDI-PUE sample has an additional and quite distinctive peak at 370 nm. In the presence of air, the peak at 370 nm for MDI-PUE is completely extinguished, while the sharp peaks at 310 nm for TDI-PU and MDI-PUE and the broad band above 400 nm are only marginally quenched by oxygen. The oxygen quenching effect is most noticeable in the lifetime diminution of the transients at 320 nm and 370 nm. The decay of the transients of nitrogen saturated MDI-PUE ( $5.5 \times 10^{-3}$  g/dL in THF) absorbing at 320 nm and 370 nm readily fit to first order decay functions with (see insert in Figure 2 for decay curve of 320 nm) lifetimes of 6.9  $\mu$ s and 5.9  $\mu$ s, respectively (Table I). The decay of the peak at 320 nm is insensitive to oxygen (7.0  $\mu$ s in air; 6.9  $\mu$ s in nitrogen saturated) while the decay of the 370 nm transient is severely quenched in an air saturated solution (Table I). At this point, a general word about the lifetimes in Table I is in order. As will become apparent in the next few paragraphs, each of the transient peaks discussed in this section will be interpreted in terms of a radical species. In a solvent such as THF, which has readily attractible hydrogens, the most likely mode of reaction of radical species is by hydrogen abstraction which proceeds by pseudo (the solvent concentration is large and essentially constant) first order kinetics. The lifetimes in Table I are

simply the result of fitting the experimental data to a single exponential decay function. In each case an excellent statistical fit was obtained.

It should be noted that at the excitation wavelength employed, the absorbance of MDI-PUE is 1.1 while the absorbance of the solvent THF is 0.3. This is a condition dictated by polymer solubility considerations and choice of excitation wavelength. We are confident that the spectral results for the photolysis at 248 nm are derived from radicals generated by direct excitation, as opposed to radical abstraction by solvent radicals, since the kinetic curves indicate no delay in radical formation of the transients.

In order to interpret the results for MDI-PUE and TDI-PU, the laser flash photolysis measurements of several model systems were performed. The transient spectra of the p-toluidinyl radical, recorded upon laser flash photolysis ( $\lambda_{\text{ex}}=248$  nm) of p-toluidine ( $1.4 \times 10^{-4}$  M in THF), has a distinct maxima at approximately 310 nm and a broad, diffuse absorbance above 400 nm (Figure 3). The results for p-toluidine are in agreement with previously reported spectra for anilinyl type radicals (12, 13). Comparing the transient spectra for p-toluidine with TDI-PU and MDI-PUE, it is quite obvious that the p-toluidinyl radical in THF (Figure 5) is essentially identical to the 300-330 nm and > 400 nm portions of the transient spectra of MDI-PUE and TDI-PU in Figures 1 and 2. Furthermore, the 6.0  $\mu\text{s}$  lifetime of the p-toluidinyl radical (measured at 310 nm in nitrogen saturated THF), which places it very close to the lifetime (7.0  $\mu\text{s}$ ) for the

higher energy component ( $\lambda_{\text{max}}$  at 310 nm) of the transient in Figure 1, is not quenched by oxygen (see Table I). Similar results are obtained for the laser flash photolysis ( $\lambda_{\text{ex}}=248$  nm) of aniline ( $5.1 \times 10^{-4}$  M) in THF which has a lifetime of 6.2  $\mu\text{s}$  (Table I) for the anilinyl radical in nitrogen (6.3  $\mu\text{s}$  in air) saturated THF.

Before assigning the 310 nm and 400 nm bands in the TDI-PU and MDI-PUE transient spectra (Figures 1 and 2), the laser flash photolysis of propyl N-tolylcarbamate ( $1.3 \times 10^{-4}$  M) was recorded in THF ( $\lambda_{\text{ex}}=248$  nm). The transient spectrum of propyl N-tolylcarbamate is very similar to the spectrum reported for propyl N-phenylcarbamate (13). For propyl N-tolylcarbamate, the peaks at 310 nm, 340-360 nm and  $> 400$  nm (Figure 4) are identical to three of the four peaks in the transient spectrum of MDI-PUE and the three peaks in TDI-PU. In addition, the lifetime (single exponential decay function fit) of the transient measured at 310 nm is 6.0  $\mu\text{s}$  in nitrogen saturated THF (Table I), in excellent agreement with the results obtained for p-toluidine. Thus, by analogy with p-toluidine, the 310 nm (sharp peak) and 400-450 nm band in the transient spectrum of propyl N-tolylcarbamate can be attributed to the p-toluidinyl radical. These results are readily translated into assignment of the 310 nm and 400-450 nm bands in the TDI-PU and MDI-PUE transient spectra (Figures 1 and 2) to p-toluidinyl type radicals. Anilinyl type radicals have been previously implicated as an intermediate in the photolysis of aryl carbamates and their presence is certainly expected (4-6).

The broad band absorbance between 340 and 360 nm in Figures 1, 2 and 6 is somewhat more difficult to identify since there is no direct literature precedence as there is for the aniliny radical. However, from Porter's (12) investigation of N-substituted aniliny transients, one might speculate that this band could result from absorbance by an N-propylcarboxy substituted p-toluidiny radical. It is not unreasonable that substitution of the N-propylcarboxy group on a p-toluidiny radical could red shift the absorbance from 310 nm (unsubstituted aniliny radical) to 340-360 nm. A final assignment of this peak depends on laser flash photolysis studies of N-methylated derivatives of propyl N-arylcarbamates currently in progress.

The next peak under consideration in the transient spectrum (Figure 1) of MDI-PUE is the sharp peak at 370 nm which, as we have noted previously (Table I), is quite sensitive to oxygen. Figure 5a shows the transient absorbance spectrum ( $\lambda_{ex}=248$  nm) of the bispropyl carbamate of MDI (designated BP-MDI) in dichloromethane ( $2.7 \times 10^{-5}$  M). (We recently reported a similar spectrum for BP-MDI in THF (13)). As in the case of MDI-PUE (Figure 1), the transient spectrum of BP-MDI in Figure 5a has bands at 310 nm (sharp peak), 340-360 nm (broad peak), 370 nm (sharp peak) and above 400 nm (weak, diffuse broad band absorbance). Only the peak at 370 nm is readily quenched by oxygen. From the investigations of Porter and Windsor (14), it is well known that photolysis of diarylmethanes results in a C-H bond cleavage and formation of diarylmethyl radicals. In the case of diphenylmethane, the diphenylmethyl radical has a very

sharp absorbance maximum at ~ 335-340 nm. Substitution at the para positions, such as is the case with BP-MDI and the biscarbamate group in the MDI-PUE polymer, would be expected to red shift the absorbance maximum. Thus, the peak at 370 nm in Figures 1 and 5a can be tentatively postulated to arise from the absorbance of a 4,4'-disubstituted diphenylmethyl radical.

In order to provide corroborative evidence for the assignment of the 370 nm peak to a diphenylmethyl radical, a diphenyl dimethyl silane analog of the BP-MDI model compound was prepared (see structure below for this compound which is designated SiMe<sub>2</sub>-MDI). Obviously formation of a diphenylmethyl radical upon photolysis of SiMe<sub>2</sub>-MDI is impossible. Accordingly, the transient absorbance spectrum recorded for the laser flash photolysis ( $\lambda_{ex}=248$  nm) of SiMe<sub>2</sub>-MDI (Figure 5b) in dichloromethane ( $2.6 \times 10^{-5}$  M) has peaks at 310 nm (sharp), 340-360 nm (broad), and above 400 nm (broad, weak diffuse), but no sharp peak at 370 nm. Apparently, all of the structural features exhibited by the SiMe<sub>2</sub>-MDI transient spectrum are found in the transient spectrum of BP-MDI, save the 370 nm peak. This certainly provides additional evidence for assigning the 370 nm peak to a substituted diphenylmethyl radical.

The next section deals with the use of independently generated tert-butoxy transient species which are capable of abstracting hydrogens from the polyurethanes and the model compounds. The results derived from the indirect method of generating transients will be used to substantiate the findings in this section.

Laser Flash Photolysis of tert-Butyl Peroxide/Benzene Solutions  
Containing MDI-PUE and Model Compounds at 351 nm.

Photolysis of tert-butyl peroxide (TBP) results in a highly efficient production of tert-butoxy radicals. It has recently been shown (15) that tert-butoxy radicals generated by the laser flash photolysis of TBP can rapidly extract hydrogen atoms from appropriate substrates such as aniline and diphenylamine (Scheme III).

Scheme III

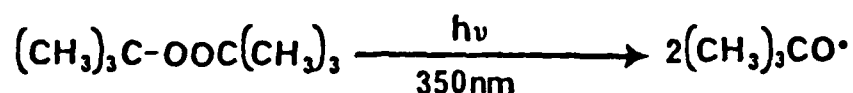

Results of an experiment for the laser flash photolysis ( $\lambda_{\text{ex}}=351$  nm) of a  $6.0 \times 10^{-2}$  M solution of diphenylmethane in a 60/40 mixture of TBP and benzene (Figure 6) shows the distinct absorbance peak maxima at 340 nm characteristic of the unsubstituted diphenylmethyl radical. No detectable transient species were generated above 350 nm by the laser flash photolysis ( $\lambda_{\text{ex}}=351$  nm) of the 60/40 mixture of TBP and benzene. The results in Figure 6 illustrate the utility of TBP in indirect generation of diphenylmethyl radicals.

The laser flash photolysis ( $\lambda_{ex}=351$  nm) of a TBP/BP-MDI solution in benzene (Figure 7) yields a transient spectra with distinct maxima at 370 nm which based upon the results in Figure 6 can most likely be attributed to a substituted diphenylmethyl radical. (Similar results are obtained in other solvents such as DMF). Results for the TBP/MDI-PU ( $7.0 \times 10^{-2}$  g/dL) system shown in Figure 8 shows as in the case of the model BP-MDI (Figures 7), that the transient spectrum of MDI-PU obtained indirectly through tert-butoxy radicals has a maximum at 370 nm. This provides additional support for assignment of the transient species responsible for the 370 nm absorbance to a diphenylmethyl radical.

It is possible to directly monitor the formation and decay of the transient of BP-MDI at 370 nm (peak) by recording the absorbance as a function of time. Figure 9 shows a semi-log plot of the buildup and decay in the absorbance at 370 nm which is complete by about 6  $\mu$ s after firing the laser. This rise represents the time required for the hydrogen abstraction process of the central methylene hydrogen by the tert-butoxy radical. [The tert-butoxy radical does not absorb at the monitoring wavelength (370 nm)]. The decay of the 370 nm transient is on a much longer time scale. In fact, by fitting the longer times of a log absorbance versus time plot (Figure 9) to an exponential decay function a lifetime of 77.8  $\mu$ s is obtained. The lifetime of the 370 nm transient in TBP/C<sub>6</sub>H<sub>6</sub> is over an order of magnitude longer than in THF (see Table I). No doubt the 370 nm transient, which we have tentatively assigned to the diphenylmethyl radical,

generated by direct photolysis in THF readily abstracts a hydrogen from the solvent resulting in a short lived species. The TBP/C<sub>6</sub>H<sub>6</sub> solvent system has no easily abstractable hydrogens and the transient is much longer lived in this mixture. In summary, Figure 8 is important in providing a means of directly observing the formation and decay of the proposed diphenylmethyl radical.

### CONCLUSIONS

The results in this paper support an N-C bond cleavage mechanism (Schemes I and II) for the photolysis of both TDI and MDI based polyurethanes. The substituted anilinyl radicals observed no doubt are formed by diffusion from a solvent cage after the primary N-C bond cleavage. Although not specifically shown in this paper, the reported photo-Fries products (6) are probably formed by attack of the carboxyl radical on the phenyl ring before radical diffusion occurs. The solvent separated anilinyl radicals rapidly abstract hydrogens from the solvent to give the reported aromatic amine product (6), the lifetime of the substituted anilinyl radicals depending upon the solvent medium.

For MDI based polyurethanes, we have provided evidence for formation of a diphenylmethyl radical by direct excitation (248 nm) of the carbamate moiety as well as hydrogen abstraction by a tert-butoxy radical which is produced by excitation (351 nm) of tert-butyl peroxide. The diphenylmethyl radical readily reacts with oxygen. A proposed mechanism which accounts for the production (direct or indirect) and subsequent reaction with oxygen of the diphenylmethyl radical is shown in Scheme IV. The

hydrogen peroxide product depicted in Scheme IV has been previously identified by FT-IR (7), we have simply provided a plausible mechanism for its formation.

SCHEME IV

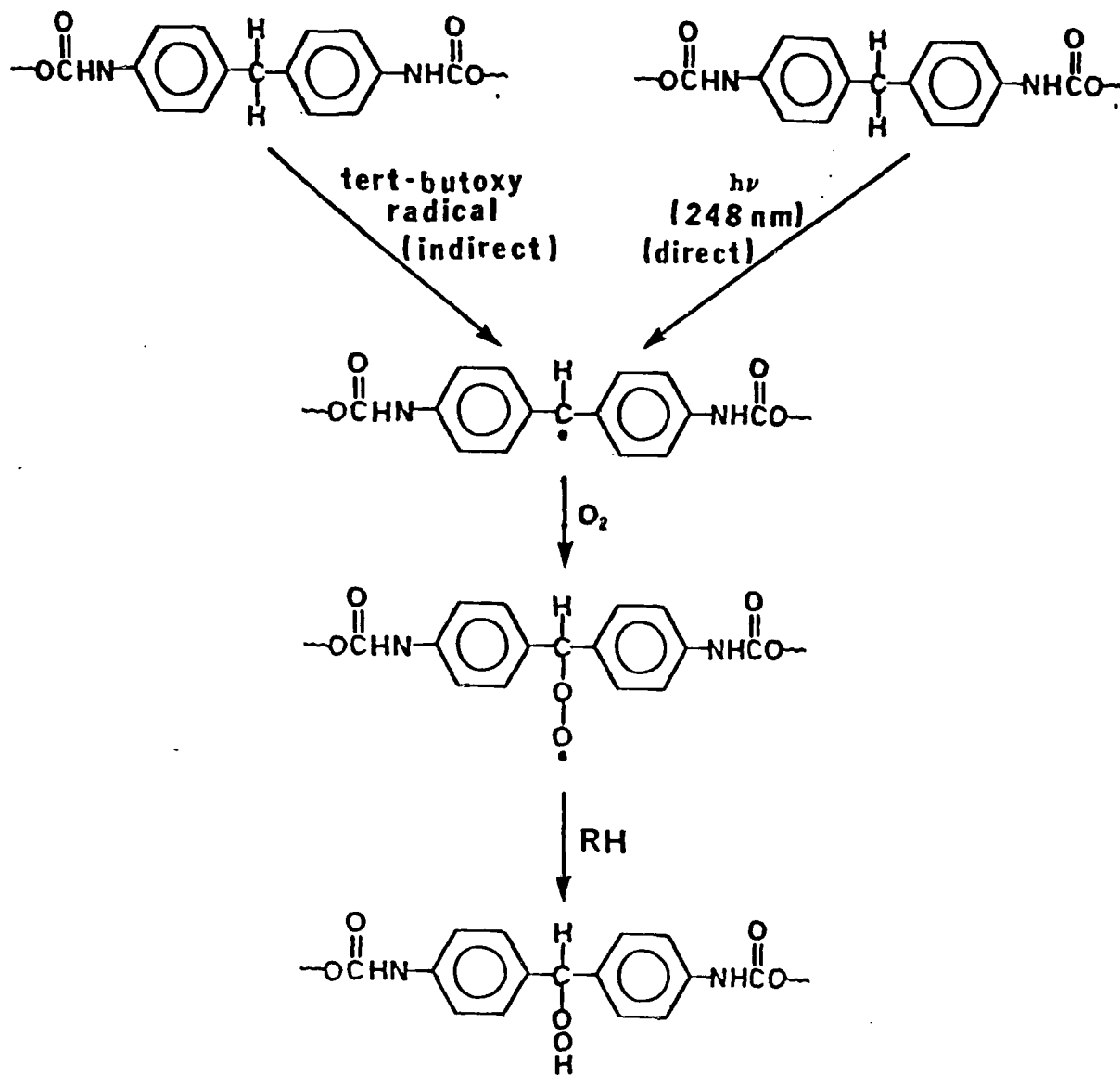

Finally, the use of TBP to produce photolytically the tert-butoxy radical has not only proven to be an excellent mechanistic tool for independently generating key radicals, but it also serves as a model for peroxide impurities which may be present in actual polyurethanes. Such peroxide impurities may well be introduced into polyurethanes during processing or upon the initial stages of exposure to terrestrial irradiation.

Future work will be concerned with quantitative measurement of hydrogen abstraction rates of labile hydrogens in the carbamate moieties of several aromatic diisocyanate based polyurethanes. It is expected that experimental conditions will alter significantly the hydrogen abstraction rate. Emphasis will also be placed on measurement of transient intermediates in polyurethane films. Finally, extensive laser flash photolysis experiments will be conducted on polyurethanes based on both 2,4-toluenediisocyanate and 2,6-toluenediisocyanate. Preliminary data suggest that the placement of the methyl substituent can alter the nature of the transient intermediates formed.

Acknowledgement. This work was sponsored in part by the Office of Naval Research. In addition, acknowledgement is made to the donor of the Petroleum Research Fund, administered by the American Chemical Society, for partial support of this research. Acknowledgement is also made to NSF for assistance in purchasing the laser flash photolysis unit (Grant CHE-8411829-Chemical Instrumentation Program).

## REFERENCES

1. C. S. Schollenberger and F. D. Stewart, J. Elastoplastics, 4, 294 (1972).
2. C. S. Schollenberger and F. D. Stewart, Advances in Urethane Science and Tchnology, Vol. II, ed. by K. C. Frisch and S. L. Reegen, Technomic Publishing, Connecticut, USA (1973).
3. L. V. Nevskii, O. kG. Tarakanov, and V. K. Beljakov, Soviet Plastics, 7, 45 (1966).
4. H. C. Beachell and I. L. Chang, Polym. Sci., Part A. 10, 503 (1972).
5. Z. Osawa, E. L. Cheu, and Y. Ogiwara, J. Polym. Sci., Letter Ed., 13, 535 (1975).
6. C. E. Hoyle and K. J. Kim, J. Polym. Sci. Chem. Ed., 24, 1879 (1986).
7. J. L. Gardette and J. Lemaire, Polym. Deg. and Stab., 6, 135 (1984).
8. C. E. Hoyle and J. E. Herweh, J. Org. Chem., 11, 2195 (1980).
9. J. R. Pratt, W. D. Massey, F. H. Pinkerton and S. F. Thames, J. Org. Chem., 40, 1090 (1975).
10. D. J. Lyman, J. Polym. Sci., 45, 409 (1960).
11. J. H. Saunders and K. C. Frisch, "Polyurethanes: Chemistry and Technology," Vol. XVI, p. 273, Interscience Publishers, New York, 1962.
12. E. J. Land and G. Porter, Trans Faraday Soc., 59, 2027 (1963).

13. C. E. Hoyle, Y. G. No, K. G. Malone and S. F. Thames,  
Macromolecules, accepted.
14. G. Porter and W. R. Windsor, Nature, 180, 187 (1957).
15. M. S. Platz, E. Leyva, B. Niu and J. Wirz, J. Phys. Chem.,  
91, 2293 (1987).

TABLE I. Decay Times of Transient Intermediates in THF.

<u>Compound</u>	<u>Solution Condition*</u>	<u>Observation Wavelength</u>	<u>First-Order Decay Time (<math>\mu</math>s)</u>
MDI-PUE	N <sub>2</sub>	320 nm	6.9
MDI-PUE	Air	320 nm	7.0
MDI-PUE	N <sub>2</sub>	370 nm	5.9
MDI-PUE	Air	370 nm	<< 1.0
Aniline	N <sub>2</sub>	310 nm	6.2
Aniline	Air	310 nm	6.3
p-Toluidine	N <sub>2</sub>	310 nm	6.0
p-Toluidine	Air	310 nm	6.0
Propyl N-tolyl carbamate	N <sub>2</sub>	310 nm	5.9

---

\*Entries indicate whether solution is air or nitrogen saturated.

### FIGURE CAPTIONS

- Figure 1. Transient absorption spectra ( $2.0 \mu\text{s}$ ) of  $2.3 \times 10^{-3}$  g/dL TDI-PUE in THF (a) Nitrogen saturated (b) Air saturated.
- Figure 2. Transient absorption spectra ( $2.0 \mu\text{s}$ ) of  $5.5 \times 10^{-3}$  MDI-PUE in THF (a) Nitrogen saturated (b) Air saturated. Insert shows first order decay of absorbance versus time observed at 320 nm ( $\lambda_{\text{ex}} = 248$  nm).
- Figure 3. Transient absorption spectrum ( $2.0 \mu\text{s}$ ) of  $1.4 \times 10^{-4}$  M p-toluidine in nitrogen saturated THF ( $\lambda_{\text{ex}}=248$  nm).
- Figure 4. Transient absorption spectra ( $2.0 \mu\text{s}$ ) of (a)  $1.3 \times 10^{-4}$  M propyl N-tolylcarbamate in nitrogen saturated THF ( $\lambda_{\text{ex}}=248$  nm).
- Figure 5. Transient absorption spectra ( $2.0 \mu\text{s}$ ) of (a)  $2.7 \times 10^{-5}$  M BP-MDI in nitrogen saturated dichloromethane ( $\lambda_{\text{ex}}=248$  nm) (b)  $2.6 \times 10^{-5}$  MSiMe<sub>2</sub> MDI in nitrogen saturated dichloromethane ( $\lambda_{\text{ex}}=248$  nm).
- Figure 6. Transient absorption spectrum ( $12.0 \mu\text{s}$ ) of  $6.0 \times 10^{-2}$  M diphenylmethane in a nitrogen saturated TBB/C<sub>6</sub>H<sub>6</sub> (60/40) solution ( $\lambda_{\text{ex}}=351$  nm).

Figure 7. Transient absorption spectrum (10.0  $\mu$ s) of  $3.5 \times 10^{-3}$  M TBP/BP-MDI in a nitrogen saturated TBP/C<sub>6</sub>H<sub>6</sub> (60/40) solution ( $\lambda_{ex}$ =351 nm).

Figure 8. Transient absorption spectrum (15.0  $\mu$ s) of  $7.0 \times 10^{-2}$  g/dL MDI-PU in a nitrogen saturated TBP/DMF (60/40) solution ( $\lambda_{ex}$ =351 nm).

Figure 9. First order decay plot of absorbance versus time of BP-MDI transient in a nitrogen saturated TBP/C<sub>6</sub>H<sub>6</sub> (60/40) solution observed at 368 nm.

Fig 1

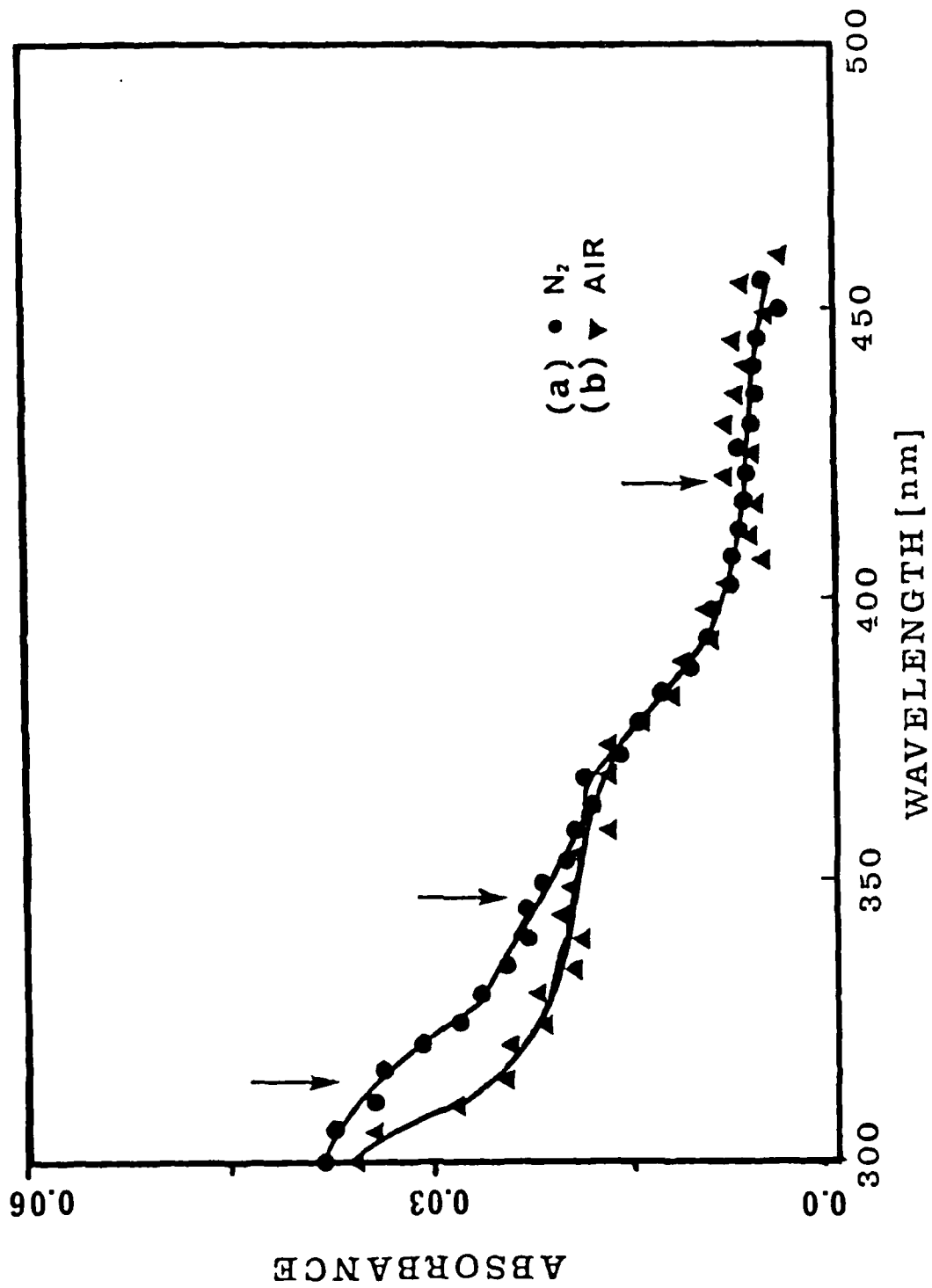

Fig 2

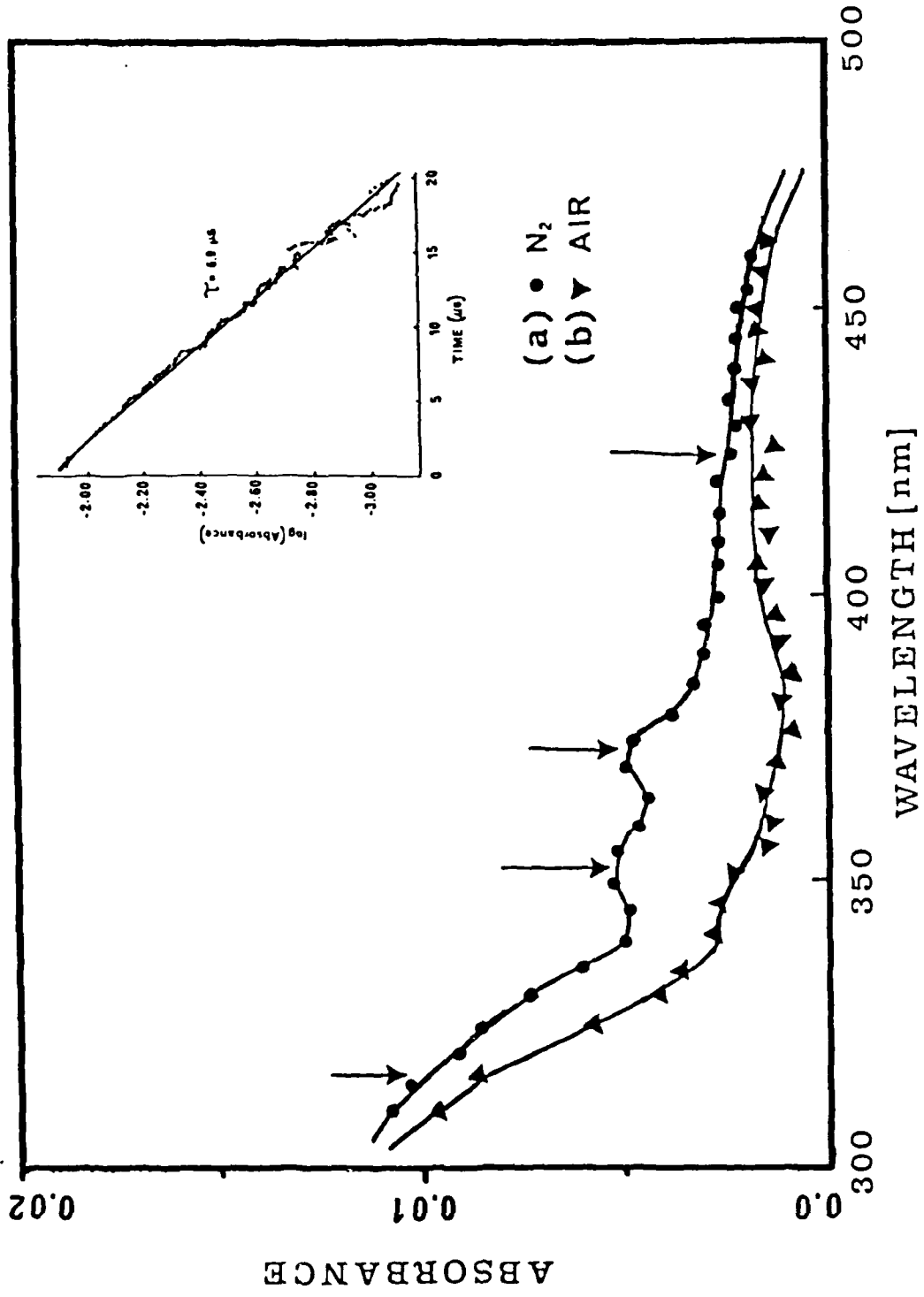

Fig. 3

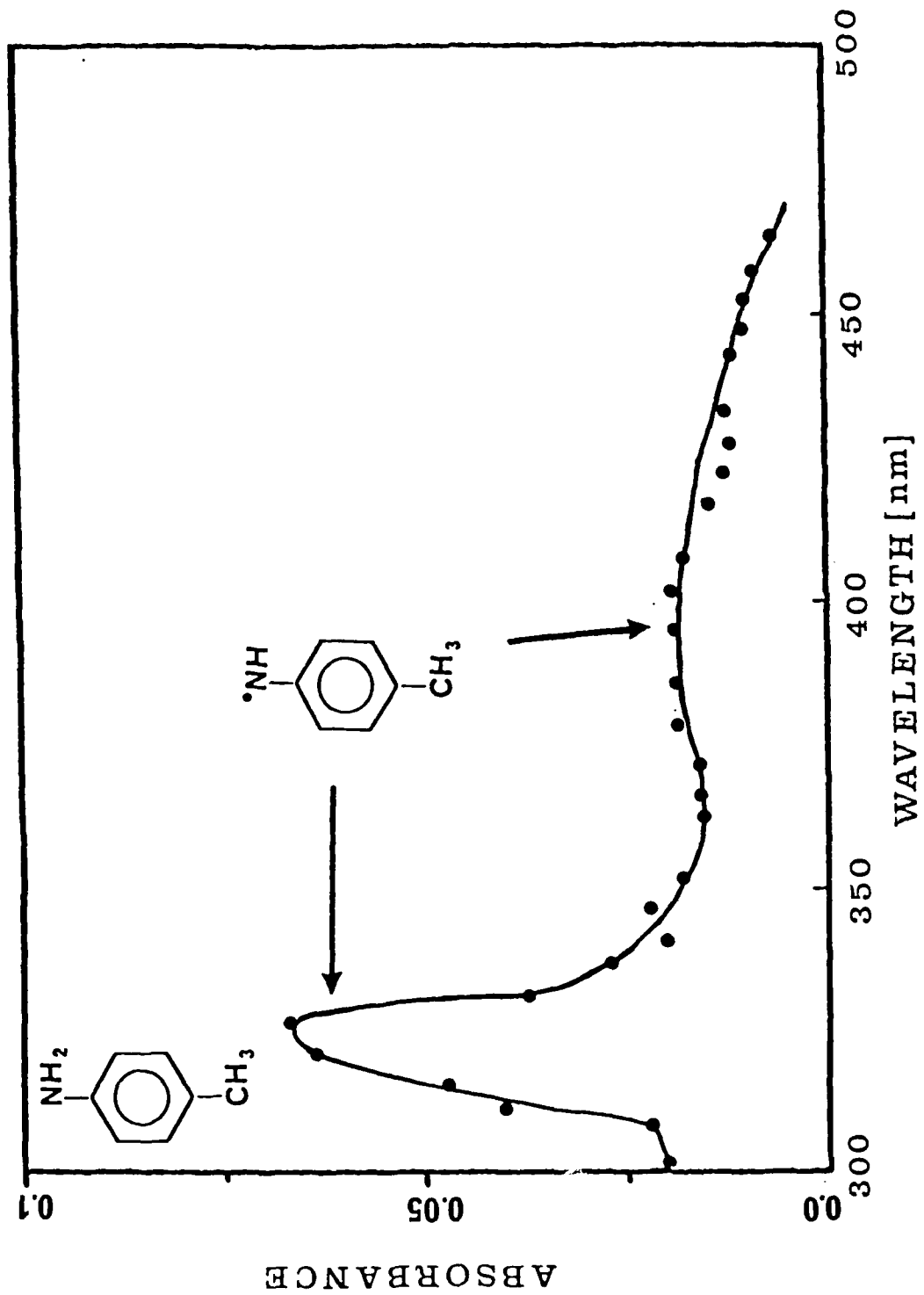

Fig. 4

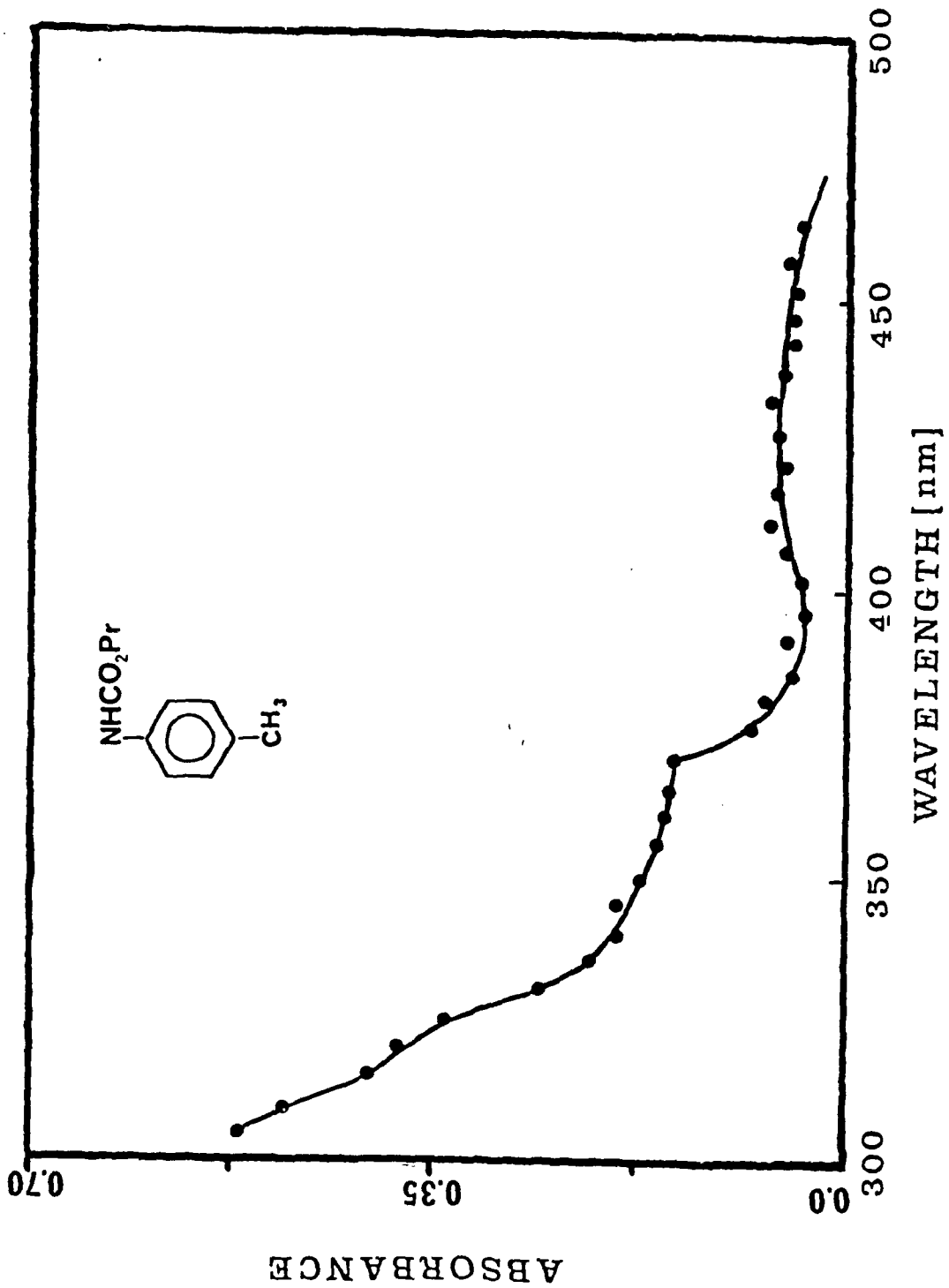

Fig. 5

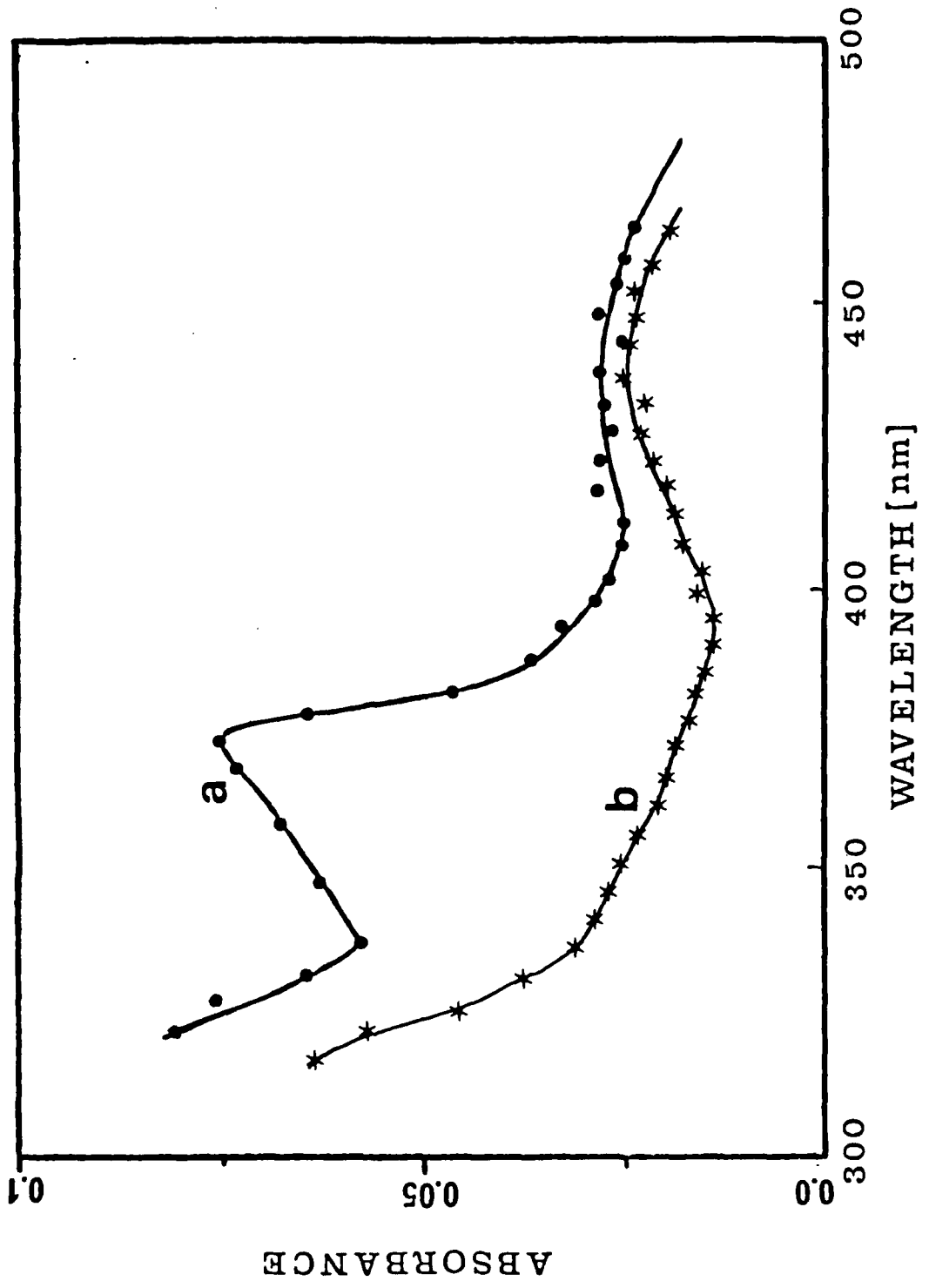

Fig. 6

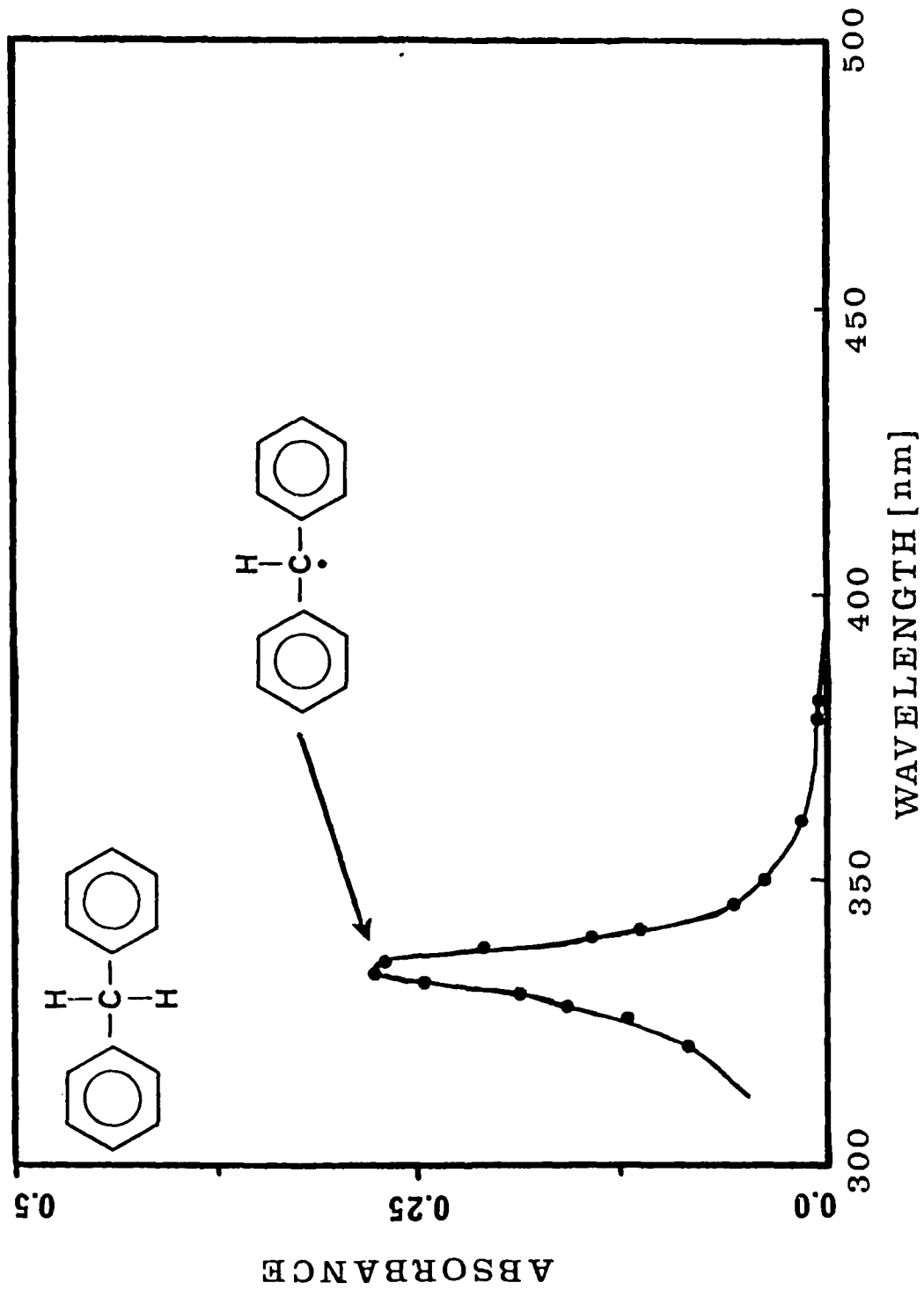

Fig. 17

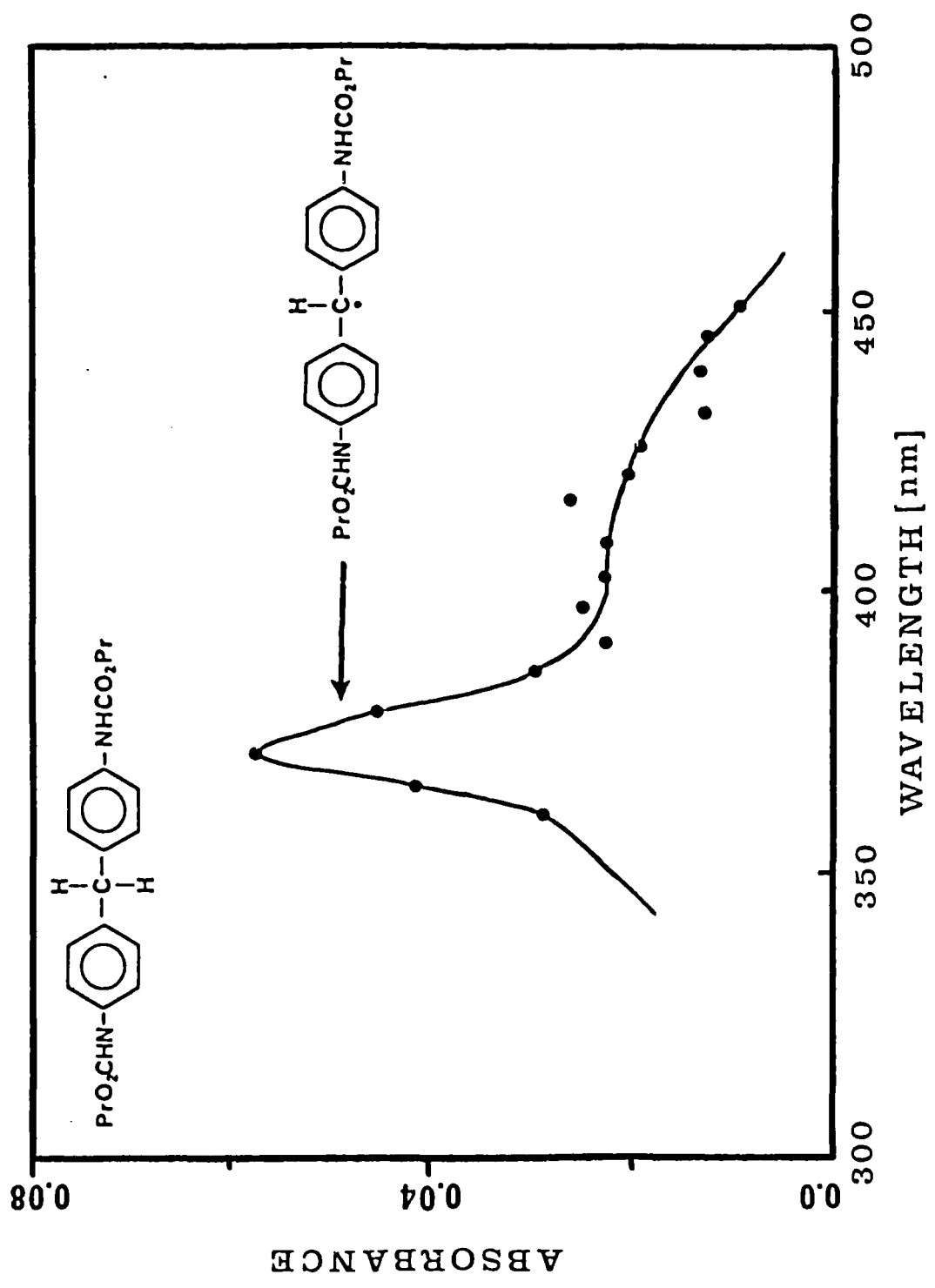

Fig. 8

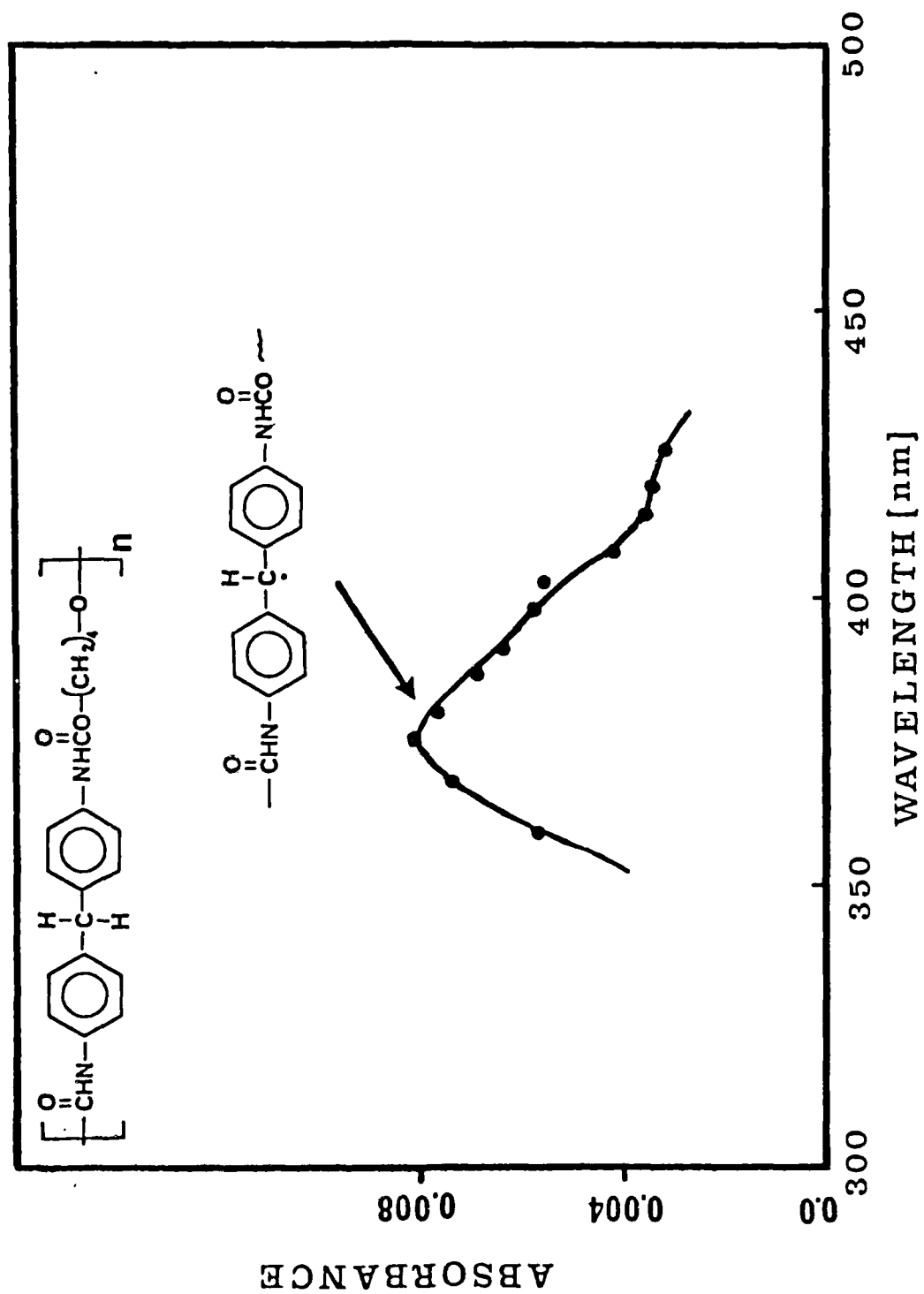
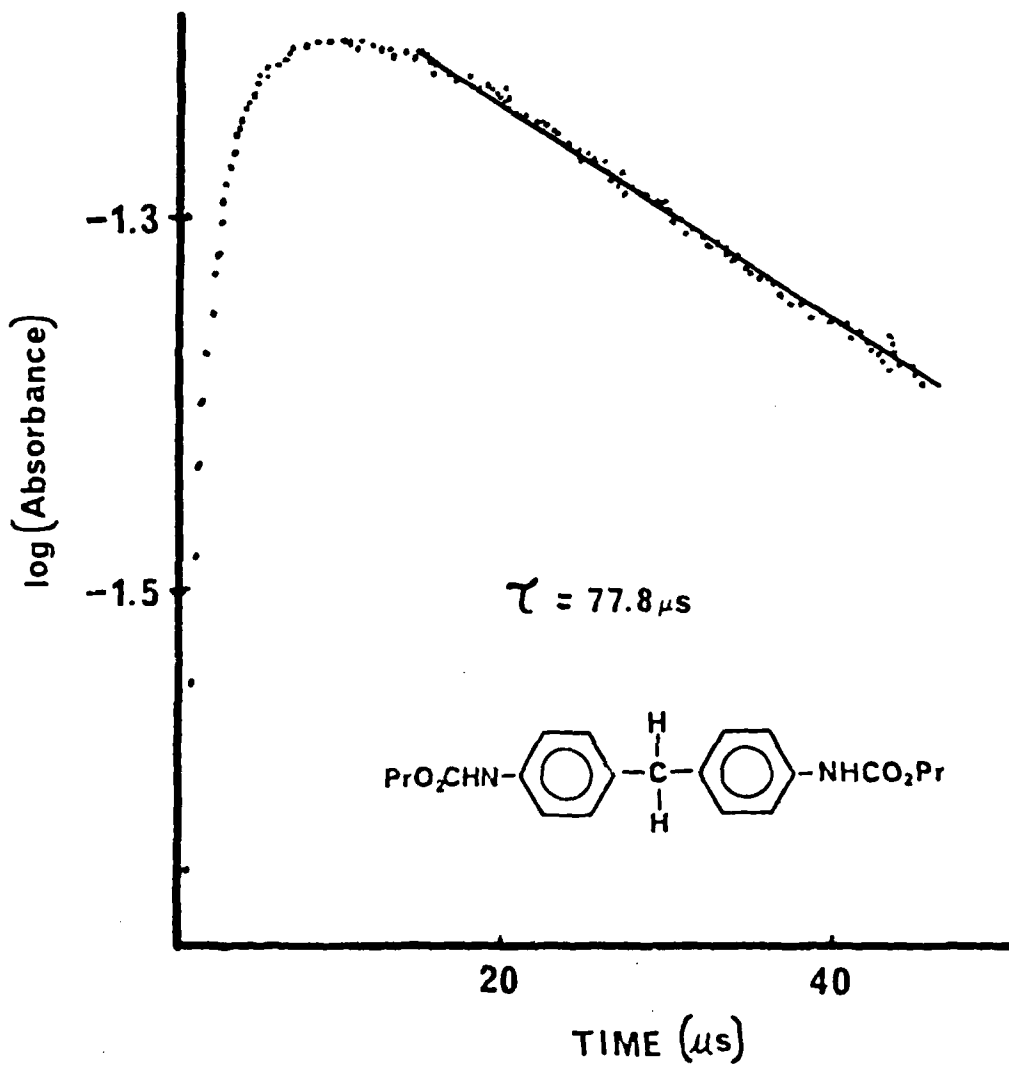

Fig. 9



END

DATE

FILMED

6-1988

DTIC