

AD-A192 060

SUGGESTION PROGRAM AND MODEL INSTALLATION PROGRAM -
DUPLICATION OF EFFORT(U) AIR COMMAND AND STAFF COLL
MAXWELL AFB AL D C TROWBRIDGE APR 88 ACSC-88-2620

1/1

UNCLASSIFIED

F/G 5/1

ML

FILE
DATE
CLASS
BY
NO.

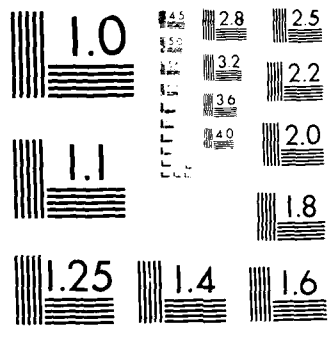

MICROCOPY RESOLUTION TEST CHART
NATIONAL BUREAU OF STANDARDS 1963-A

AD-A192 868



AIR COMMAND AND STAFF COLLEGE

STUDENT REPORT

SUGGESTION PROGRAM AND MODEL INSTALLATION
PROGRAM--DUPLICATION OF EFFORT?

MAJOR DONALD C. TROWBRIDGE 88-2620

"insights into tomorrow"

S DTIC
ELECTE **D**
MAY 13 1988
E

This document has been approved
for public release and sale in
distribution is unlimited.

88 5 10 221



REPORT NUMBER 88-2620

TITLE SUGGESTION PROGRAM AND MODEL INSTALLATION PROGRAM--DUPLICATION OF EFFORT?

AUTHOR(S) MAJOR DONALD C. TROWBRIDGE, USAF

FACULTY ADVISOR MAJOR STEVEN L. HANSEN, ACSC/3824 STUS

SPONSOR LT COL RUSSELL E. ZURAWKA, HQ USAF/PRMI

Submitted to the faculty in partial fulfillment of
requirements for graduation.

AIR COMMAND AND STAFF COLLEGE
AIR UNIVERSITY
MAXWELL AFB, AL 36112-5542

UNCLASSIFIED

SECURITY CLASSIFICATION OF THIS PAGE

REPORT DOCUMENTATION PAGE				Form Approved OMB No. 0704-0188	
1a. REPORT SECURITY CLASSIFICATION UNCLASSIFIED			1b. RESTRICTIVE MARKINGS		
2a. SECURITY CLASSIFICATION AUTHORITY		3. DISTRIBUTION / AVAILABILITY OF REPORT STATEMENT A Approved for public release; Distribution is unlimited.			
2b. DECLASSIFICATION / DOWNGRADING SCHEDULE					
4. PERFORMING ORGANIZATION REPORT NUMBER(S) 88-2620			5. MONITORING ORGANIZATION REPORT NUMBER(S)		
6a. NAME OF PERFORMING ORGANIZATION ACSC/EDC		6b. OFFICE SYMBOL (If applicable)	7a. NAME OF MONITORING ORGANIZATION		
6c. ADDRESS (City, State, and ZIP Code) Maxwell AFB AL 36112-5542			7b. ADDRESS (City, State, and ZIP Code)		
8a. NAME OF FUNDING / SPONSORING ORGANIZATION		8b. OFFICE SYMBOL (If applicable)	9. PROCUREMENT INSTRUMENT IDENTIFICATION NUMBER		
8c. ADDRESS (City, State, and ZIP Code)			10. SOURCE OF FUNDING NUMBERS		
			PROGRAM ELEMENT NO.	PROJECT NO.	TASK NO.
			WORK UNIT ACCESSION NO.		
11. TITLE (Include Security Classification) SUGGESTION PROGRAM AND MODEL INSTALLATION PROGRAM--DUPLICATION OF EFFORT?					
12. PERSONAL AUTHOR(S) Trowbridge, Donald C., Major, USAF					
13a. TYPE OF REPORT		13b. TIME COVERED FROM _____ TO _____	14. DATE OF REPORT (Year, Month, Day) 1988 April		15. PAGE COUNT 34
16. SUPPLEMENTARY NOTATION					
17. COSATI CODES			18. SUBJECT TERMS (Continue on reverse if necessary and identify by block number)		
FIELD	GROUP	SUB-GROUP			
19. ABSTRACT (Continue on reverse if necessary and identify by block number)					
<p>The Suggestion Program and the Model Installation Program (MIP) are both productivity improvement or enhancement-related programs. The Suggestion Program focuses on providing a means for government employees to submit an idea for improving operations and receive an award for their contribution. The MIP is designed to create an "Excellent Installation" more efficient and effective in mission accomplishment. Today's austere budget requires the Air Force to eliminate as much duplication as possible to keep manpower costs at the minimum. This study looks at these two programs' objectives, processes, costs, and benefits to determine if they are both essential as distinct programs. The author concludes that the programs should be put under the same office of primary responsibility (OPR) at all levels. Eventually, the two programs should be consolidated into one mission improvement/enhancement-related program.</p>					
20. DISTRIBUTION / AVAILABILITY OF ABSTRACT <input type="checkbox"/> UNCLASSIFIED/UNLIMITED <input checked="" type="checkbox"/> SAME AS RPT. <input type="checkbox"/> DTIC USERS			21. ABSTRACT SECURITY CLASSIFICATION UNCLASSIFIED		
22a. NAME OF RESPONSIBLE INDIVIDUAL ACSC/EDC Maxwell AFB AL 36112-5542		22b. TELEPHONE (Include Area Code) (205) 293-2867		22c. OFFICE SYMBOL	

DD Form 1473, JUN 86

Previous editions are obsolete.

SECURITY CLASSIFICATION OF THIS PAGE

UNCLASSIFIED

PREFACE

The Suggestion Program and the Model Installation Program (MIP) are both productivity improvement or enhancement-related programs. They are concerned with doing Air Force business better, and in some cases, faster and cheaper to gain the maximum from every defense dollar spent. The MIP is a commander's program designed to give him or her an avenue to cut the "red tape" and create the best installation possible for mission accomplishment. The Suggestion Program can also do this, although in a more indirect way, and also recognize the innovator with an award. This study looks at the two programs' designs, processes, and benefits to determine if they should be combined into one mission improvement or mission enhancement program.

The author would like to take this opportunity to thank a few Air Force professionals for their advice, guidance, and commitment to Air Force excellence. Lt Col Kathy LaSauce (HQ USAF/PRPJA), Maj Truman Bolden (HQ MAC/XPME), and Ms Marcy Loina (HQ AFMEA/MERS) have been patient and helpful in every way possible. A special thanks goes to the author's advisor, Maj Steven L. Hansen. His accurate feedback, understanding, and unmatched professional skill were motivating factors toward successful project completion.

Accession For	
NTIS GRA&I	<input checked="" type="checkbox"/>
DTIC TAB	<input checked="" type="checkbox"/>
Unannounced	<input type="checkbox"/>
Justification	
By _____	
Distribution/	
Availability Codes	
Dist	Avail and/or Special
A-1	



ABOUT THE AUTHOR

Major Donald C. Trowbridge graduated from Montana State University in 1973 with a Bachelor of Science Degree in Civil Engineering. After completing USAF Undergraduate Pilot Training at Columbus AFB, Mississippi, he became a T-38 instructor/check pilot at Webb AFB, Texas, until 1977. Following instructor duty, he went to McGuire AFB, New Jersey, where he was a C-141 airdrop and air refueling qualified instructor, flight examiner, and wing standardization/evaluation pilot. In 1982, he transferred to Andrews AFB, Maryland, where he flew as a C-135 special air mission aircraft commander. In 1984, he moved to Headquarters Military Airlift Command (MAC) at Scott AFB, Illinois. During this assignment, Major Trowbridge served in the Manpower and Organization Directorate as a manpower requirements officer, a branch chief, and the Chief, Management Engineering Division. As a division chief, he was responsible for many and varied MAC manpower programs including the functional review/manpower standards development program, the Productivity Enhancement Program, the Suggestion Program, and the Model Installation Program. While at Scott, Major Trowbridge graduated from Webster University with a Master of Arts (MA) Degree in Management and completed the National Defense University's National Security Management course.

TABLE OF CONTENTS

Preface.....	iii
About the Author.....	iv
List of Illustrations.....	vi
Executive Summary.....	vii
CHAPTER ONE--INTRODUCTION	
Statement of Purpose.....	1
Study Objectives.....	1
Limitations.....	2
Overview.....	2
CHAPTER TWO--BACKGROUND OF PROGRAMS	
Suggestion Program Background.....	3
Model Installation Program Background.....	6
Summary.....	8
CHAPTER THREE--PROGRAM PROCESSES	
Suggestion Program Process.....	10
Model Installation Program Process.....	12
Summary.....	14
CHAPTER FOUR--PROGRAM STATISTICS	
Suggestion Program Statistics.....	15
Model Installation Program Statistics.....	16
Summary.....	19
CHAPTER FIVE--CONCLUSIONS AND RECOMMENDATIONS	
Conclusions.....	20
Recommendations.....	21
BIBLIOGRAPHY.....	23

LIST OF ILLUSTRATIONS

TABLES

TABLE 1--Suggestion Program Statistics.....	15
TABLE 2--Suggestion Program Employees.....	16
TABLE 3--MIP Man-hour Data.....	18

FIGURES

FIGURE 1--Suggestion Program Process.....	11
FIGURE 2--MIP Evaluation Process.....	13
FIGURE 3--USAF MIP Growth.....	17

EXECUTIVE SUMMARY



Part of our College mission is distribution of the students' problem solving products to DOD sponsors and other interested agencies to enhance insight into contemporary, defense related issues. While the College has accepted this product as meeting academic requirements for graduation, the views and opinions expressed or implied are solely those of the author and should not be construed as carrying official sanction.

"insights into tomorrow"

REPORT NUMBER 88-2620

AUTHOR(S) MAJOR DONALD C. TROWBRIDGE, USAF

TITLE SUGGESTION PROGRAM AND MODEL INSTALLATION PROGRAM--DUPLICATION OF EFFORT?

I. Purpose: To determine whether the Suggestion Program and the Model Installation Program (MIP) should be combined into one mission improvement or mission enhancement-related program in the Air Force.

II. Problem: The Air Force employs many programs designed to improve mission effectiveness, efficiency, and productivity. Some programs like the Contract Cost Comparison Program, Zero-Overpricing, or the Economies and Efficiencies Program are sufficiently different to keep as separate enhancement efforts. However, programs like the Suggestion Program and the MIP appear to achieve similar objectives in much the same manner. With today's austere budget and in the interest of efficient use of manpower resources, these two programs should be considered for consolidation.

III. Data: The author explores three areas for comparison. The first area covers the background, purpose, and objectives of each program. The Suggestion Program and the MIP are both

CONTINUED

productivity and efficiency oriented in their purpose and objectives. The Suggestion Program focuses on providing a means for government employees to submit an idea for improving operations and receive an award for their contribution. The MIP is designed to create an "Excellent Installation" that is more efficient and effective in mission accomplishment. The second area in the study centers on program processes for submitting and evaluating proposals. The Suggestion Program and MIP processes are similar in that they both use the "office of primary responsibility" (OPR) chain of command for staffing proposals. In the Suggestion Program, an employee can submit an idea to the base Suggestion Program Manager who, in turn, sends it to the base-level OPR for evaluation. The suggestion must ultimately go to the highest level OPR with approval authority for a final decision. Evaluators should make their decision in the best interest of the Air Force. MIP proposals, on the other hand, are processed through the installation commander, who must concur with the proposal's content before it is sent to higher headquarters for action. Once a MIP proposal leaves an installation for staffing, higher headquarters should approve the request unless it is illegal or harmful to the Air Force. This guideline makes it easy to approve and difficult to disapprove a MIP proposal. Finally, the study focuses on program statistics. Both programs continue to perform well with quality proposals and good benefits. In FY 87, the Suggestion Program increased its adoption rate and annual savings 20 and 25 percent respectively over FY 86. At the same time, the number of proposals received decreased 22 percent. The number of MIP proposals increased significantly in FY 87, with its expansion to include all Air Force installations in January 1987. Also, the MIP showed some hard dollar savings, one of which increased Air Force combat capability equivalent to one additional C-141 aircraft. There are 280 full- and part-time employees who manage the Suggestion Program and approximately 65 man-years of work related to MIP management.

IV. Conclusions: The Suggestion Program and the MIP have very similar, if not duplicative, purposes and objectives, types of initiatives, and processes for staffing proposals. Also, the MIP is a much faster way for ideas to be staffed. The average evaluation time is 30-60 days, assuming Air Staff approval is necessary. A suggestion, on the other hand, takes 4-6 months for Air Staff approval. Finally, both programs are beneficial to the Air Force in tangible and intangible savings. The manpower cost associated with program management is nominal, but the work is redundant since the programs have similar purposes, types of initiatives, and processes.

CONTINUED

V. Recommendations: Based on the commonality of the programs, the Suggestion Program and the MIP should be put under one common OPR at all levels and ultimately be consolidated into one program. This common OPR should be the Manpower and Organization community, since it is already responsible for many productivity-related programs including the Suggestion Program. The consolidated program should take advantage of each program's good points such as the MIP's staffing process with a quick turnaround time and the Suggestion Program's awards for the contributors. Consolidation will allow the Air Force to (1) benefit from innovative ideas and award members for their contributions under one program, (2) improve program efficiency through better use of manpower for program management, and (3) keep commanders involved in determining better ways to do the Air Force mission.

Chapter One

INTRODUCTION

STATEMENT OF PURPOSE

Today's United States Air Force employs many programs to achieve productivity and efficiency excellence. To name a few, there are the following: Economies and Efficiencies Program, Productivity Enhancement Program, Zero-Overpricing, Contract Cost Comparison Program, Logistics Excellence Program, Suggestion Program, and Model Installation Program. There are at least a dozen more, and all are designed to more effectively accomplish a mission by finding better ways of managing valuable Air Force resources, leading people, or both. With today's austere budget environment, the Air Force must continue to gain the maximum from every dollar spent. Programs like these are a necessity, but how many does the Air Force need? Two of these programs appear very similar. Specifically, the Suggestion Program and the Model Installation Program are both "initiative" or "suggestion" oriented. What are their program objectives? Do they do the same thing? In the interest of productivity and efficiency, shouldn't the Air Force consider consolidating programs that are duplicative? The purpose of this study is to answer these and other questions about the programs, and ultimately answer the question, "Should the Air Force Suggestion Program and the DOD Model Installation Program/Command Model Installation Programs (MIP/CMIP) be combined into one mission improvement or enhancement program in the Air Force?"

STUDY OBJECTIVES

The overall objective of the study is to logically support a recommended course of action for either consolidating the Suggestion Program and the MIP/CMIP or keeping the two programs separate. The specific objectives are to (1) identify and explain the basis, purpose, and objectives of the two programs, (2) discuss the processes for initiating and staffing proposals through the programs, (3) determine manpower costs and offices of primary responsibility for operating the existing programs in a representative sample of Air Force major commands, (4) investigate tangible and

intangible savings generated from the existing programs and identify successes in staffing proposals during an equivalent period of time, (5) compare and contrast the existing programs based on their purposes, processes, costs, and savings, and (6) identify the pros and cons of combining the existing programs into one Air Force mission improvement or enhancement program.

LIMITATIONS

The author has limited this study in two respects. First, when discussing the Suggestion Program, this study focuses on problem/solution-type suggestions, since 98.5 percent of the Suggestion Program proposals adopted over the past 3 years have been this type (16:3). The other types, scientific achievements, inventions, or patents, are processed in a different manner and have separate provisions in Air Force Regulation (AFR) 900-4 (11:32-34). Second, this study is designed to determine if the programs should be consolidated and not determine specific procedures and policies for a new consolidated program.

OVERVIEW

Chapter Two contains the background of each program to include their basis, purpose or objectives, and policies and guidelines. This chapter lays the necessary foundation for the remainder of the study.

Chapter Three discusses each program's process from initiation through staffing (evaluating), approval/disapproval, and implementation.

Chapter Four focuses on program statistics. It conveys manpower costs, tangible and intangible savings (benefits), and the number of proposals evaluated and adopted in each program.

Chapter Five concludes by comparing and contrasting the existing programs based on their purposes, processes, costs, and savings. It also gives the author's recommendations based on the study contents.

Chapter Two

BACKGROUND OF PROGRAMS

The Air Force Suggestion Program and the MIP/CMIP are both based on the common desire to improve the productivity and effectiveness of the Air Force. This chapter sets a common basis for the reader by looking at each program separately and providing the basis, purpose or objectives, general guidelines, and policies of the programs.

SUGGESTION PROGRAM BACKGROUND

History and Basis of Program

The Suggestion Program has been in existence since before the Air Force became a separate service. During World War II, efficiency, speed, effectiveness, and conservation were paramount to supporting the War Department effort. To provide incentive for its one million civilian employees, the War Department started the suggestion and awards system.

In June 1943, the suggestion program was announced throughout the Department and actively promoted as "Ideas for Victory." This war-born plan encouraged all War Department employees to submit their suggestions on practical ways and means for increasing the quantity and quality of performance, for eliminating unessential methods or procedures, for simplifying routine, for improving safety practices and for new or improved devices for war production (17:1).

The new program was highly successful from the outset. In the last two years of World War II, new initiatives saved more than \$100 million--an astronomical figure if translated to today's dollars (17:1). Civilian employees received appropriated fund cash awards, and military personnel received token awards such as 3-day passes. In 1965, legislation sponsored by the Air Force led to Public Law 89-198. This new law entitled both military and civilian personnel to receive cash awards through appropriated funds (17:2).

This historical development serves as an initial basis for the current Air Force Suggestion Program. Continuing authority and basis for the program is in DOD Directive 5120.15, 13 August 1985 (9:--), and DOD Instruction 5120.16, 15 July 1974 (10:--). These form the foundation for the purpose and objectives of the program as outlined in AFR 900-4.

Purpose and Objectives

Current Air Force management philosophy at all levels turns more toward the workers for efficiency and improvement ideas. The Suggestion Program's purpose fully supports this philosophy through its primary and secondary aims. First, the program is designed to justly evaluate ideas from the total force and equitably reward innovators for their efforts to do the Air Force mission better. AFR 900-4 states the Suggestion Program's primary purpose best.

The Air Force Suggestion Program recognizes and rewards individuals whose suggestions, inventions, patents, and scientific achievements improve efficiency, economy, and effectiveness of the Air Force, Department of Defense (DOD), and federal government operations (11:5).

The secondary purpose, a corollary to the first, is to "contribute significantly to improving government productivity and services" (11:5). This one naturally follows if the first aim of "recognition and reward" is successful.

There are seven different objectives of the program that point out the need for the program. AFR 900-4 identifies the following (11:5):

- a. Motivate personnel to suggest practical ways to increase effectiveness and efficiency in the Air Force, DOD, and other federal government operations.
- b. Improve morale by providing an opportunity for members and employees to voluntarily take part in the management of the Air Force.
- c. Provide a formal channel for communications between management and personnel.
- d. Provide an organized method for employees to submit constructive ideas.
- e. Foster and maintain an atmosphere that invites participation, cooperation, imagination, creativity, and innovation.
- f. Provide evaluation that is unbiased, consistent, prompt, and efficient.

- g. Promptly and equitably recognize all eligible persons who improve government operations.

In essence, the program is designed to solicit ideas, communicate ideas, invite innovation and participation, and recognize ideas with rewards.

Policies and Guidelines

General policies and guidelines presented here include eligibility criteria for the suggester and the suggestion, basis for award computations, confirmatory suggestions, and office of primary responsibility (OPR) for program management. Basically, any Air Force military or civilian government employee paid from appropriated funds is eligible to participate. This includes Air Force Academy and Reserve Officer Training Corps cadets, Air Force Reserve personnel, and Senior Executive Service personnel. Private citizens, contractor personnel, and foreign exchange members are eligible for honorary awards. Air National Guard Technicians and nonappropriated fund employees participate under separate regulations (11:5-6). Eligible suggestions must be in writing and describe a problem, provide a workable solution, and outline expected Air Force benefits. "The suggestion must be the suggester's own thoughts. . . . [and] . . . must do one or more of the following" (11:11,37):

- (1) Simplify or improve operations.
- (2) Save time.
- (3) Speed up production.
- (4) Increase output and enhance productivity.
- (5) Improve working conditions; procedures; operating methods; or equipment, plant layouts, and organizations.
- (6) Save material or property.
- (7) Save manpower or money.
- (8) Promote health.
- (9) Increase safety.
- (10) Improve morale through desirable and feasible personnel services that increase productivity.
- (11) Save energy.
- (12) Hold down procurement costs.
- (13) Improve reliability and maintainability.
- (14) Provide enhancements listed in (1) to (13) above for functional reviews.

Award computations are based on whether the suggestion will result in tangible or intangible benefits or both. Tangible benefits are measurable savings (1 year) (11:61). Intangible benefits are gains which can't be computed in

specific monetary terms (11:60). Awards can range from a non-monetary certificate up to a maximum of \$25,000 (11:39,40).

Air Force Regulation 900-4 also describes policy on "confirmatory" or "after-the-fact" suggestions as it applies to MIP proposals. Basically, the contributor may submit a confirmatory suggestion for a MIP proposal after it is either approved for testing or when the test period is over and the proposal is adopted. When the idea is first introduced as a MIP, "the contributor must submit an AF Form 1000 that reflects his or her organization, Air Force specialty code (AFSC), and title at the time the MIP was suggested" (11:13).

A final guideline for discussion is the OPR at each level for managing the Suggestion Program. As of April 1986, Suggestion Program supervisory responsibility rests with the Deputy Chief of Staff, Programs and Resources, at the Air Staff. The Director, Manpower and Organization, exercises this responsibility and the Air Force Suggestion Program Manager (SPM) is assigned to the Air Force Management Engineering Agency (AFMEA) (11:6). Major command and base-level SPMs are assigned to the Manpower and Organization Directorate and the Management Engineering Team respectively (11:7).

MODEL INSTALLATION PROGRAM BACKGROUND

History and Basis of Program

In 1983, Mr Robert A. Stone, Deputy Assistant Secretary of Defense for Installations, initiated the MIP in the Department of Defense. His initial idea and motivation to create "Excellent Installations" (21:1) was inspired by two documents. The first was an Air Force installation management study completed in May 1983. This study concluded that "The local commander must retain control of base support functions to effectively perform the mission" (14:1). The other document, In Search of Excellence by Thomas J. Peters and Robert H. Waterman, Jr, provided "lessons learned from best run American corporations" (14:1). Mr Stone invited the services to participate in the new program, and the Air Force enthusiastically supported the MIP with three bases as test participants. Kirtland AFB (MAC), Moody AFB (TAC), and Whiteman AFB (SAC) were the original bases and initiated their programs in January 1984 for a 3-year test. In December 1984, the Deputy Secretary of Defense (DEPSECDEF) expanded the program, and the Air Force added seven more bases. In March 1986, the DEPSECDEF directed a MIP Graduate Program with the idea " . . . to apply the MIP management

philosophy to all installations . . ." (14:2). The Air Force responded with increased publicity on the program, and the Air Force Chief of Staff, General Welch, set a goal to ". . . establish a command-wide MIP program by January 1987" (19:1). As it stands now, the initial "test" period of the MIP has been extended indefinitely, and every major Air Force installation is a participant.

Purpose and Objectives

Much like the Suggestion Program, the MIP is efficiency and productivity improvement oriented. However, the MIP is strictly designed to help the local commander do his or her mission better. The underlying purpose of the MIP management approach is "to create 'Excellent Installations' which are effective in mission accomplishment, efficient in providing services needed by the base population, and excellent places for people to work and live" (20:1-2). This underlying purpose has been valid from the program's initiation in 1983 and forms the basis for several program objectives.

In order to help the local commander create his or her "Excellent Installation" through improved leadership and resource management, the MIP has four objectives. First, a successful program should encourage innovation, incentives, management flexibility, and information sharing (21:1). Second, and probably most important, it should remove impediments to efficiency or eliminate unneeded rules and regulations (22:1). The third objective is to delegate more authority to the doers and set decision authority at the lowest viable level. Finally, the program should allow commanders to keep and reinvest savings from local initiatives to improve working and living conditions (14:1). MIP initiatives that streamline work methods, promote efficient use of resources, revise cumbersome or redundant work procedures, or make needed changes in policies, organizations, controls, and regulations support these objectives.

Policies and Guidelines

Policies and guidelines for the MIP are limited in order to keep with the overall MIP philosophy of less regulation and control from upper management. There are some basic elements that major commands are encouraged to adopt. The Air Staff outlined the following in a message to the field when the program expanded to include all Air Force installations (20:2):

- A. The base host commander is the "Gatekeeper." Proposals requiring higher level approval should be authorized by the commander before forwarding.

- B. Commander's requests for waivers should follow the chain of command until they reach the level with approval authority.
- C. Identify an overall focal point (OPR) at each level of command to deal with MIP initiatives. Additional OPRs should be identified throughout the functional staff to facilitate the review and approval process.
- D. Make it easy to approve and difficult to disapprove new ideas. The function of headquarters staff review of a commander's request is to decide if it's legal and possible--not if it's a good idea. Suggest command section review of all disapprovals.
- E. Develop a "quick answer" system to shorten the time required to approve waiver request. Each echelon of review should act on a request within three working days. If you don't have the authority to approve it, forward it quickly up channel.
- F. Feedback from the installation on approved waivers is important. It helps identify ideas which may have broader application and lets the approving authority see the benefit of giving the commander more flexibility.
- G. Cross-flow of ideas is extremely valuable. Spread the word about improvements in procedures and changes in regulations. Let other people share in the success.

The Air Staff OPR for the MIP is the Special Activities Division of the Programs and Evaluation Directorate (20:3). The OPRs vary throughout the major commands, but are generally in the Plans and Programs or Manpower and Organization Directorate at a major command headquarters (24:--). Base-level OPRs are generally under the wing commander, the vice commander, or one of the deputy commanders.

SUMMARY

This chapter discussed the programs' backgrounds to include their history and basis, purpose and objectives, and policies and guidelines. As described, both programs are productivity and efficiency oriented. The purpose and objectives of the Suggestion Program focus on providing a means for government employees to submit an idea for improving government operations and receive an award for the idea if it is approved. The MIP's purpose and objectives support the program's goal to create an "Excellent Installation" for improved mission accomplishment. The chapter closed with a

look at the programs' general policies and guidelines. The next chapter discusses the process for submitting and staffing proposals in each of the programs.

Chapter Three

PROGRAM PROCESSES

SUGGESTION PROGRAM PROCESS

The Suggestion Program process follows the chain of command through applicable OPRs at each level. Figure 1 is the author's depiction of the process (11:15,29-31). There are three basic steps in the process including initiation, evaluation, and implementation and award consideration (11:5).

The first step is initiation. The suggester originates the idea, completes an AF Form 1000, and submits the completed form to the base-level SPM. As mentioned in Chapter Two of this study, the suggester must describe a problem or a specific area for improvement, propose a viable solution (in detail), and provide expected benefits if the change is approved for adoption (11:11). Once the SPM receives a completed AF Form 1000, he or she reviews the proposal for eligibility and completeness, assigns a suggestion number, and forwards the suggestion to the local OPR to begin the second step in the process--evaluation.

The evaluation step is when OPRs enter into the process. As shown in Figure 1, the local OPR has three options during evaluation. First, if within approval authority, the OPR may approve or disapprove the idea and send a completed AF Form 162, Suggestion Evaluation and Transmittal, to the base SPM. Second, he or she may approve or disapprove the suggestion (still within authority), but since the idea could be used beyond the OPR's level of responsibility (base OPR in this case), the OPR must send an AF Form 162 to the next higher level OPR. The third option assumes the OPR does not have approval authority. In this case, he or she should forward a recommendation for approval or disapproval to the next higher level OPR. (Note: When there is no OPR for the suggestion at intermediate headquarters, the base OPR sends the completed AF Form 162 directly to the major command headquarters OPR.) The OPR at each level has the same three options; however, evaluation time for each level differs. The base-level OPR has 30 days to evaluate the suggestion and send the completed AF Form 162. Intermediate headquarters and major

OPTIONS FOR ROUTING
AF FORM 162:

1. Approves or disapproves suggestion (within authority).
2. Approves or disapproves suggestion, but application is also beyond scope of area or responsibility.
3. Recommends approval or disapproval (not within authority).

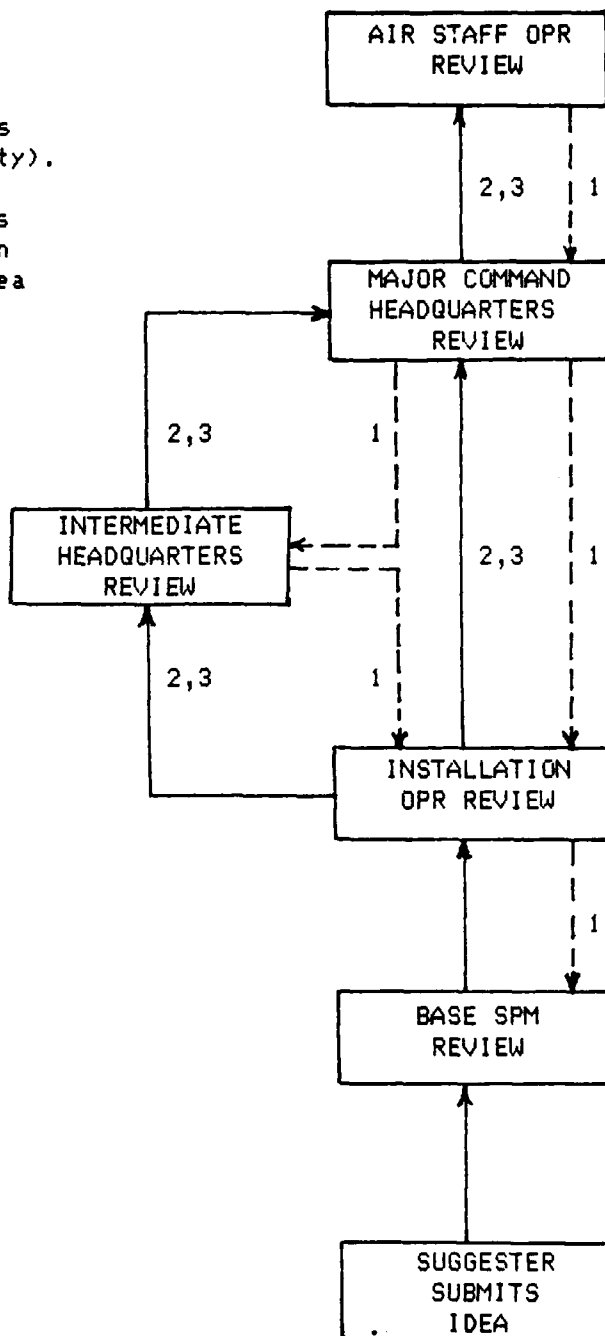

NOTE:
After review, evaluator must send a copy of the completed AF Form 162 to the installation OPR and SPM (original goes to next evaluator).

Figure 1. Suggestion Program Process

command headquarters have 60 days, the Air Staff OPR has 90 days, and DOD has 120 days. The average evaluation time for a suggestion requiring base-level approval is 30-45 days. For major command headquarters, it is 90 days, and for Air Staff or higher approval, the evaluation time could be at least 4-6 months (30:--). Once the suggestion is approved or disapproved, "suggestion files are returned [down] through OPR channels. The OPR at every level reviews and forwards responses from higher levels within 7 days of receipt unless there is a reason for reconsideration" (11:29).

The final step of the Suggestion Program process is implementation and award consideration. Implementation is the responsibility of the OPR (11:25). This is important as the SPM can't give an award until the suggestion is fully implemented or the OPR gives sufficient evidence it is being implemented (11:37). The SPM is responsible for computing and recommending an award to the appropriate award authorities (authorized by the installation commander). Base level authorities can approve awards up to \$8,000, and major command award authorities can approve awards up to \$10,000. Additional awards above \$10,000 must be referred to the Air Force SPM (HQ AFMEA/MERS) for coordination with DOD authorities (11:39).

MODEL INSTALLATION PROGRAM PROCESS

The MIP process follows much the same lines as the Suggestion Program. MIP proposals, however, are staffed and approved using standard messages between evaluators. As pointed out in Chapter Two, the MIP is a commander's program with the ultimate goal to create an "Excellent Installation." The Air Staff did not specify rules and procedures for running the program, but it did lay some general guidelines. Figure 2 depicts the MIP process from initiation of an idea through Air Staff review (1:--; 2:--; 3:--; 4:--; 5:--; 6:--; 7:--; 20:--).

There are four important points to remember when discussing the MIP process. First, the installation commander is the "Gatekeeper." He or she must approve ideas that are sent to higher headquarters for consideration (20:2). Second, proposals are normally sent through OPR channels (23:1). This is always true when going to the Air Staff, but there are a few major commands (AFLC, USAFE, AAC, and TAC) who use their MIP point of contact as the focal point for all proposals sent to their major command headquarters (1:5; 2:4; 6:1; 7:3). Thirdly, desired turnaround time at each level is 3 working days; the OPR must get an answer out as quickly as possible (20:2). This review time is a target, and four of

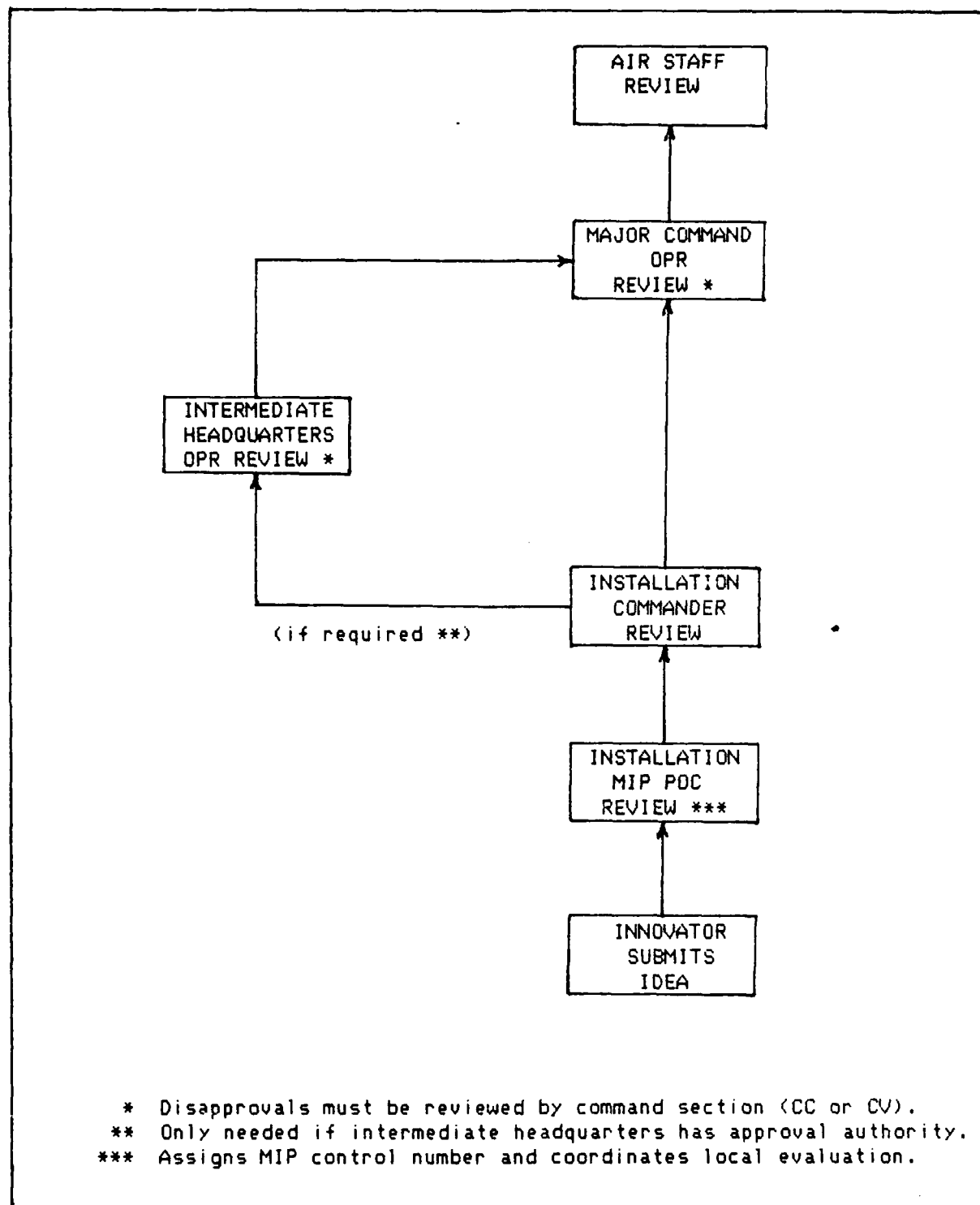

Figure 2. MIP Evaluation Process

the seven commands researched have adopted this as their goal. AFLC established 5 working days; MAC and PACAF set 7 working days as a goal (1:6; 3:3; 4:5). As a comparison to the Suggestion Program, evaluation time for a MIP proposal requiring base-level approval is 15-30 days. MIP proposals requiring Air Staff approval may take an additional 30-40 days evaluation time, including the time needed at intermediate and major command headquarters (29:--). The last point to remember about the MIP process is OPRs should approve a request unless it is illegal or harmful to the Air Force. In general, disapproval authority rests with the command section for proposals being reviewed above installation level.

SUMMARY

This chapter focused on the programs' processes. The Suggestion Program process is straightforward. In the initiation step, a suggester may submit his or her own ideas on an AF Form 1000 to the base-level SPM. Once the SPM ensures the proposal meets eligibility criteria, the SPM sends it to a local OPR to start the evaluation process. When the suggestion has been approved, the OPR must implement the change and the SPM can start award action. The entire process follows the OPR chain of command, much like the MIP process. However, the MIP process takes much less time for the contributor to get an answer on his or her idea. It also has a different philosophy on approvals and disapprovals. If commanders want to try something, they can send a request through channels for resolution. Intermediate or major command headquarters and Air Staff OPRs should approve the idea unless it is illegal or harmful to the Air Force. Finally, if a local commander receives a MIP proposal that he or she does not want to try, they may disapprove the idea at that level. The next chapter discusses each program's accomplishments and related statistics.

Chapter Four

PROGRAM STATISTICS

The Suggestion Program and the MIP have made great contributions to the Air Force's goal of increasing economies, efficiencies, and productivity. This chapter explores both programs' accomplishments with emphasis on adoption rates of initiatives, benefits, and associated manpower costs for program administration. The conclusions drawn from this information will point out program successes and trends for comparison.

SUGGESTION PROGRAM STATISTICS

Initiatives Processed and Benefits

The Suggestion Program continues to increase its contributions toward increased mission effectiveness, efficiency, and productivity. Fiscal Year 1987 was a banner year with over \$300 million tangible savings. Table 1 gives a recap of the last three fiscal years activity (15:--; 16:--).

<u>ACTIVITY</u>	<u>FY 85</u>	<u>FY 86</u>	<u>FY 87</u>
RECEIVED	108,712	83,402	65,043
ADOPTED	20,378	18,584	17,398
ADOPTION RATE	18.7%	22.3%	26.7%
SAVINGS	\$129M	\$245.6M	\$308.6M
AWARDS PAID	\$3.8M	\$3.8M	\$3.9M
PAYBACK RATIO	16:1	30:1	35:1

Table 1. Suggestion Program Statistics

As shown, the number of proposals received has decreased 40 percent since the beginning of FY 85 while the adoption rate has risen nearly 43 percent. According to the Air Force SPM, these marked changes are due to "controlling quality versus quantity as well as increasing emphasis on other programs such as the Model Installation Program (MIP)" (16:1). In any case, these are good trends since annual savings have increased by nearly 140 percent. The payback ratio is a good indication of the program's productivity. This figure gives the dollars saved for every dollar spent for cash awards and program administration (16:1).

Manpower Cost for Program Administration

The Air Force employs SPMs at 157 worldwide locations (18:--). This figure includes 146 base-level offices and 28 major command and federal agency headquarters (some are collocated with base-level offices). Table 2 gives a breakdown of the full- and part-time employees (18:--). The full-time employees are Unit Manpower Document (UMD) authorized manpower positions for Suggestion Program administration. It is the experience of the author that part-time employees are normally used to fill UMD required but not funded manpower positions. The annual dollar cost associated with program management is nearly \$5 million, using the FY 87 payback ratio of 35-to-1. (Payback ratio equals savings divided by the sum of awards paid plus cost for program management. For FY 87, 35 equals 308.6 divided by 3.9 plus 5.)

<u>TYPE EMPLOYEE</u>	<u>NUMBER OF EMPLOYEES</u>	<u>AVERAGE GRADE (GS)</u>	<u>MEDIAN GRADE (GS)</u>
FULL	242	6.56	7
PART	38	6.6	7

Table 2. Suggestion Program Employees

MODEL INSTALLATION PROGRAM STATISTICS

Initiatives Processed and Benefits

The MIP has also progressed well over the past few years. Since its beginning in 1984, the number of proposals sub-

mitted has increased steadily. As shown in Figure 3, the largest increase occurred in 1987, when the MIP expanded to include all Air Force installations (25:--).

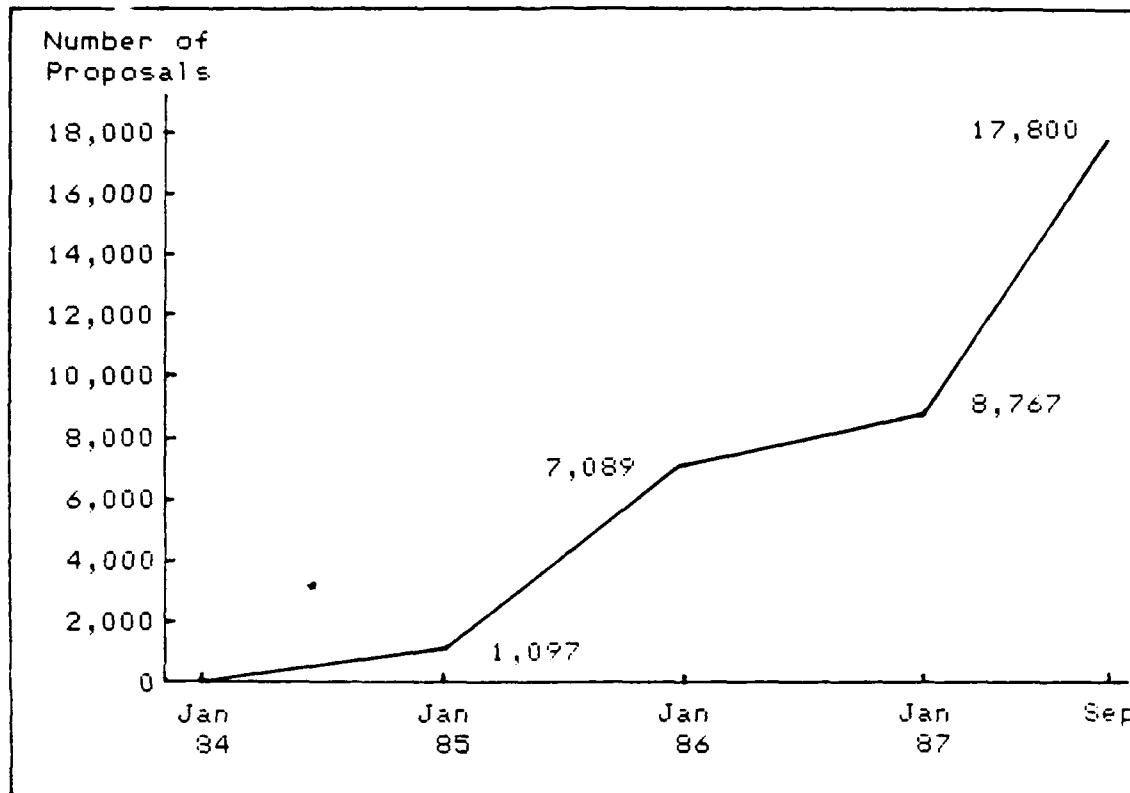

Figure 3. USAF MIP Growth

Of nearly 18,000 MIP proposals, approximately one-third have been forwarded to the Air Staff for resolution. Major command OPRs have handled another third, and the remaining have been resolved at installation level. Adoption rates vary with these three levels. At base level, installation commanders have approved 40 percent of the proposals they review. Major command headquarters have approved 75 percent, and the Air Staff has approved over 86 percent for testing (29:--). In the beginning of the program, most of the proposals were "approved for test" at a specific location. Now, "with the expansion of the program to all installations, Air Staff OPRs have immediately approved 32 percent for Air Force-wide use, without testing" (25:1).

Tangible benefits from the MIP are difficult to assess. Savings from local initiatives are reinvested locally to improve working and living conditions (a program objective from Chapter Two). However, the Air Force does benefit from initiatives that apply Air Force-wide. For example, one initiative increased combat capability by reducing downtime for required inspections on the C-141. The resultant change to required isochronal inspections gives the Air Force the equivalent of one additional C-141 aircraft (25:13). Another, increased the B-52 mission capable rate from 40 to 70 percent (25:12). Savings generated from these two alone equates to millions of dollars. The Air Force is now tracking approved MIP proposals submitted through the Suggestion Program for award action. Since 1986, 137 of 615 proposals submitted have been approved with documented savings of \$906,196 (29:--). This number is not totally representative of savings generated by the MIP, but the potential of the MIP is obvious since this represents only 4 percent of the total MIP proposals submitted. In addition to tangible savings, the MIP produces intangible benefits of decreased regulatory requirements, increased commander authority, and increased pride, professionalism, and productivity (25:9). The bottom line is (1) the MIP is succeeding in accomplishing its underlying purpose to create "Excellent Installations" and (2) tangible and intangible savings are substantial.

Manpower Cost for Program Administration

The MIP is managed as an additional duty at all levels, and as such, there are no authorized manpower positions allocated in UMDs. To estimate the manpower cost, the author obtained data, shown in Table 3, from three major commands, representing a total of 15 Air Force installations (26:--; 27:--; 28:--; 29:--).

<u>COMMAND</u>	<u>MAN-HOURS PER WEEK (Average)</u>	<u>PROPOSALS PER WEEK (Average)</u>
MAC	7.8	1.2
ATC	37.25	6.2
TAC	16.5	1.9
TOTAL	61.55	9.3

Table 3. MIP Man-hour Data

Using the above data, the average time spent for each MIP proposal at the installation level is 6.6 hours. Using 750 proposals submitted every month (9,000 a year), Air Force installations (total) spend approximately 4,950 monthly man-hours for program administration. This equates to slightly over 34 manpower positions using standard manpower management engineering computation methods and the civilian employee man-hour availability factor (12:1-2). In addition, there are MIP managers in the Air Force's 13 major command headquarters and 16 separate operating agencies. It has been the experience of the author that approximately one man-year is devoted to managing the MIP at a headquarters level. Therefore, there is a total of slightly over 63 man-years of work related to MIP management below the Air Staff level. It is also the experience of the author that military officers, lieutenants through majors, normally manage the MIP. Using an average annual composite pay rate for O-1 through O-4 military grades, the cost for 63 manpower spaces equates to nearly \$3.2 million annually for MIP management (13:34).

SUMMARY

This chapter discussed both programs' accomplishments and related statistics. Both programs have continued to perform well. The Suggestion Program has increased annual savings and the payback ratio, while the MIP has accelerated in number of proposals submitted with some definite hard dollar savings. These benefits far outweigh manpower costs associated with managing the programs. The final chapter of this study presents the author's conclusions and recommendations.

Chapter Five

CONCLUSIONS AND RECOMMENDATIONS

CONCLUSIONS

There are several logical conclusions to be made from this study. First, the Suggestion Program and the MIP have very similar efficiency and mission improvement-related purposes and objectives. The Suggestion Program solicits ideas that "improve efficiency, economy, and effectiveness, of Air Force, Department of Defense (DOD), and federal government operations" (11:5). The MIP is designed to create "Excellent Installations" that are effective in mission accomplishment. One difference between the programs' objectives is commanders may keep and reinvest savings from local MIP initiatives to improve local working and living conditions. However, MIP savings outside the local area can benefit the entire Air Force, a goal of the Suggestion Program. Another difference is the Suggestion Program awards individuals for their contributions. MIP proposals, however, can be submitted as confirmatory suggestions for appropriate recognition.

Second, suggestions meeting eligibility criteria in AFR 900-4 could also be submitted as MIP proposals. The 14 points about eligible suggestions in Chapter Two support this conclusion. A proposal relating to any of the 14 would be supportive of the MIP objectives and could be submitted as a MIP proposal.

The third conclusion is both processes for evaluating suggestions or MIP proposals are essentially the same. They both go through the OPR chain of command. The difference is MIP proposals go through the installation commander as the "Gatekeeper" and can be disapproved at higher headquarters only if the idea is illegal or harmful to the Air Force. This may be an advantage since more ideas can be tried in the MIP. One can imagine how many good ideas have been disapproved in the Suggestion Program because of an OPR's assessment, and the commander probably wouldn't know about it.

Next, the MIP process is much faster because of the desired turnaround time of 3 working days. Also, it is the experience of the author that OPRs put more emphasis on working MIP proposals, since the program is such a high interest item with commanders at all levels including the Air Force Chief of Staff.

Fifth, the Suggestion Program evaluation time at each level is too long. It is the experience of the author that the 30, 60, 90, and 120-day evaluation times at different levels causes evaluators to put suggestions "on the back burner" and sometimes forget about or lose them. This causes extra workload for Suggestion Program personnel to track down overdue suggestion evaluations and forward new suggestion case files to the evaluator.

Finally, both programs are beneficial to the Air Force with savings in the millions of dollars per year and resultant increased pride, professionalism, productivity, and morale.

RECOMMENDATIONS

As stated in Chapter One, the purpose of this study is to answer whether the Suggestion Program and the MIP should be combined into one mission improvement or enhancement program in the Air Force. The author's answer is an unequivocal "yes" with several recommendations leading to program consolidation.

First, combine program management under one OPR at all levels. This will allow the managers to continue to improve and take advantage of each program's benefits and processes, and eliminate duplication. The associated manpower in each program should be moved under this common OPR, however, decreased total manpower requirements could result as duplication is eliminated. Since the Manpower and Organization community is already responsible for many productivity-related programs including the Suggestion Program, the author suggests this be the common OPR.

The author's second recommendation is to continue to use the MIP process for staffing proposals and the confirmatory suggestion process for awarding contributors. This retains the MIP "Gatekeeper" and approval/disapproval philosophies. It also retains the capability of recognizing contributors for their ideas. All policies and guidelines for award eligibility and computation should remain the same.

Third, program managers at all levels should continue emphasizing quality of ideas and not quantity. Recent Suggestion Program emphasis in this area is succeeding with the increasing trend in the adoption rate, decreasing trend in number of proposals processed, and increasing tangible savings. This is a definite "plus" toward improving the payback ratio and productivity of the program.

Fourth, the OPR should retain the optional processes for staffing inventions, patents, and scientific achievements. Chapters 6 and 7 of AFR 900-4 already outline a streamlined process for these types of initiatives.

Fifth, after a full 1-year test of the programs under a common OPR, consolidate the programs into one mission effectiveness and productivity improvement program. In the long run, consolidating the Suggestion Program and the MIP will allow the Air Force to (1) benefit from innovative ideas and award members for their contributions, (2) improve productivity through more efficient use of available resources for program management, and (3) keep commanders involved in determining better ways to do the Air Force mission.

In his Annual Report to the Congress Fiscal Year 1988, the Secretary of Defense began his discussion on DOD productivity with the following: "A fundamental objective of DOD management is to improve mission capabilities through more efficient use of available resources" (8:107). Improved effectiveness and productivity is the challenge. Consolidating these two parallel programs is another step toward answering the challenge.

BIBLIOGRAPHY

A. REFERENCES CITED

Official Documents

1. Air Force Logistics Command. "FACER INNOVATE."
Wright-Patterson AFB, OH: HQ AFLC/XRP, 1 January 1987.
2. Alaskan Air Command. "Model Installation Program."
Program Action Directive 87-01. Elmendorf AFB, AK:
HQ AAC/MO, 28 November 1986.
3. Military Airlift Command. "VOLANT PACE." Scott AFB,
IL: HQ MAC/XPME, 15 December 1986.
4. Pacific Air Forces. "PACAF Excellence Program (PEP)."
Hickam AFB, HI: HQ PACAF/XPMM, 1 April 1986.
5. Strategic Air Command. "Command Model Installation
Program (CMIP)." Program Plan 86-17. Offutt AFB,
NE: HQ SAC/XPP, 31 December 1986.
6. Tactical Air Command. "Tactical Air Command Model
Installation Graduate Program Guidance Letter."
Langley AFB, VA: HQ TAC/DEMG, 26 November 1986.
7. United States Air Forces in Europe. "Command Model
Installation Program (CMIP)." Program Plan 4937-85.
Ramstein AB, FRG: HQ USAFE/XPP, October 1986.
8. US Department of Defense. Annual Report to the Congress
Fiscal Year 1988. Washington, DC: Government
Printing Office, 12 January 1987.
9. US Department of Defense. Office of the Assistant
Secretary of Defense (FM&P). "Authority for Approval
of Cash and Honorary Awards for DOD Personnel," DOD
Directive 5120.15. Washington, DC, 13 August 1985.
10. US Department of Defense. Office of the Assistant
Secretary of Defense (M&RA). "Department of Defense
Incentive Awards Program: Policies and Standards,"
DOD Instruction 5120.16. Washington, DC, 15 July
1974.
11. US Department of the Air Force. The Air Force Sugges-
tion Program. AF Regulation 900-4. Washington, DC:
Government Printing Office, 23 July 1987.

CONTINUED

12. US Department of the Air Force. Manpower Policies and Procedures Determining USAF Manpower. AF Regulation 26-1, Volume III. Washington, DC: Government Printing Office, 11 March 1981.
13. US Department of the Air Force. US Air Force Cost and Planning Factors. AF Regulation 173-13. Washington, DC: Government Printing Office, 2 September 1986.

Unpublished Materials

14. Rouse, Paul, Maj, USAF. "The Model Installation Program (MIP)." HQ USAF/PRPJA Point Paper, 30 September 1987.
15. US Department of the Air Force. HQ Air Force Management Engineering Agency (CC). "Air Force Suggestion Program," letter. Randolph AFB, TX, 26 August 1987.
16. US Department of the Air Force. HQ Air Force Management Engineering Agency (MERS). "Air Force Suggestion Program Narrative Evaluation FY 85-87." HQ AFMEA/MERS Background Paper. Randolph AFB, TX, undated.
17. ----. "History of the Suggestion Program 1943-1986." HQ AFMEA/MERS Background Paper. Randolph AFB, TX, undated.
18. ----. "Suggestion Program Managers." HQ AFMEA/MERS annual listing. Randolph AFB, TX, 1 September 1987.
19. US Department of the Air Force. HQ United States Air Force (CC). "Air Force-Wide Application of the Model Installation Management Approach," letter. Washington, DC, 17 September 1986.
20. US Department of the Air Force. HQ United States Air Force (PR). "Air Force-Wide Expansion of the Model Installation Management Approach," 191600Z Sep 86 message. Washington, DC.
21. ----. "Model Installation Program (MIP)," 151200Z Nov 83 message. Washington, DC.
22. US Department of the Air Force. HQ United States Air Force (PRP). "Expansion of the Model Installation Program," 041500Z Dec 84 message. Washington, DC.

CONTINUED

23. US Department of the Air Force. HQ United States Air Force (PRPJA). "Command Model Installation Program (CMIP)," letter. Washington, DC, 24 April 1987.
24. -----, "MIP Air Staff Points of Contact." HQ USAF/PRPJA listing. Washington, DC, 17 June 1987.
25. -----, "Model Installation Program," report and briefing slides. Fiscal Year 1987 report presented to the Deputy Secretary of Defense. Washington, DC, 14 December 1987.

Other Sources

26. Bolden, Truman H., Maj, USAF. Chief, Productivity Branch, HQ MAC/XPMEZ, Scott AFB, IL. Telecon, 5 January 1988.
27. Collins, Russell D., Capt, USAF. Excellent Installations Program Manager, HQ TAC/DEMG, Langley AFB, VA. Telecon, 14 January 1988.
28. Courtney, Melissa M., 1 Lt, USAF. MIP Program Manager, KTTC/XR, Keesler AFB, MS. Telecon, 11 January 1988.
29. LaSauce, Kathy, Lt Col, USAF. Chief, Special Activities Division, HQ USAF/PRPJA, Washington, DC. Telecon, 28 December 1987.
30. Loina, Marcela A., GS-6. Air Force Suggestion Program Specialist, HQ AFMEA/MERS, Randolph AFB, TX. Telecon, 28 December 1987.
31. Nelson, Porter E., Maj, USAF. GRIP Project Officer, 47 FTW/CCXL, Laughlin AFB, TX. Telecon, 11 January 1988.

B. RELATED SOURCES

Books

Peters, Thomas J. and Robert H. Waterman, Jr.. In Search of Excellence. New York, NY: Harper and Row, 1982.

END

DATE

FILMED

6-1988

DTIC