

AD-A193 846

125 INCH DIAMETER ACTUATOR(U) HR TEXTRON INC VALENCIA
CA 22 JAN 86 HR-73300162 DARH01-03-R-0106

1/1

UNCLASSIFIED

F/G 13/7

NN

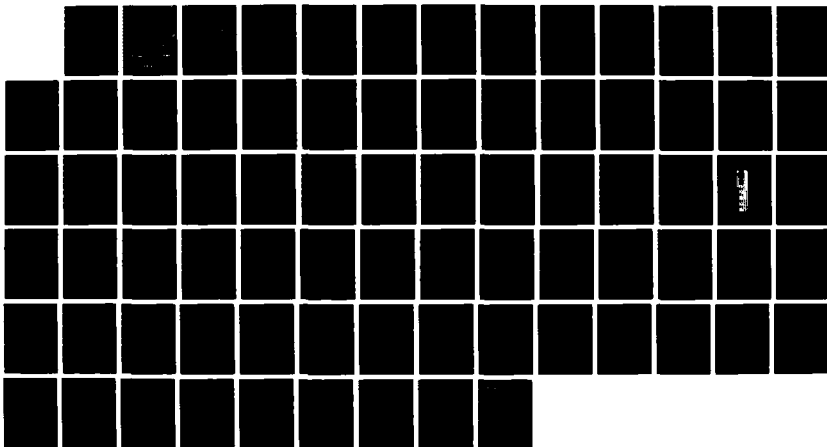

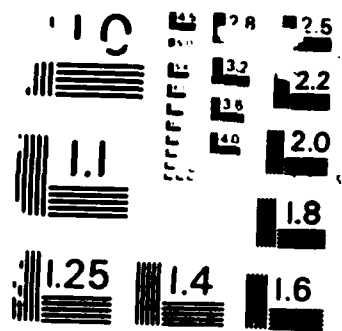

RESOLUTION TEST CHART
NATIONAL BUREAU OF STANDARDS-1963-A

DTIC FILE COPY

①

AD-A193 846

DTIC
ELECTE
APR 12 1988
S E D

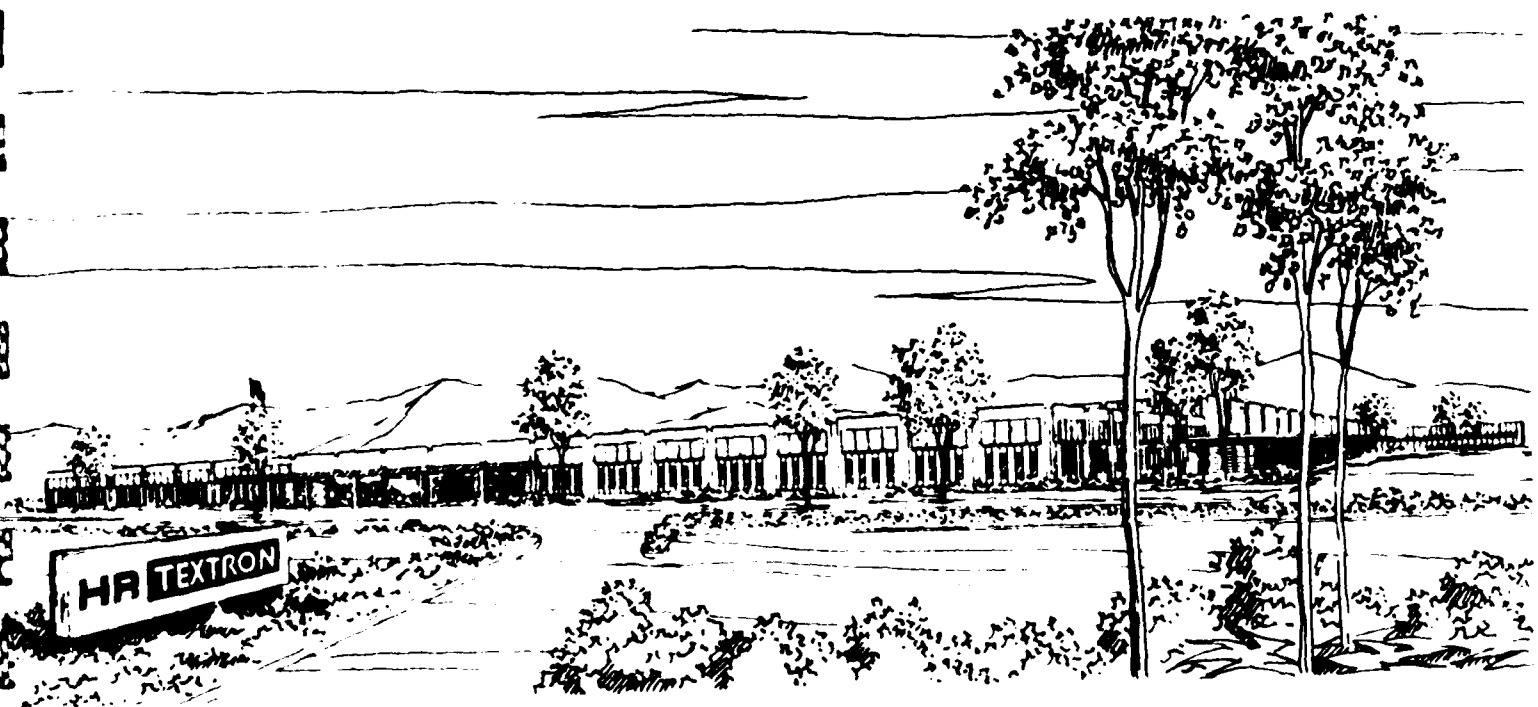

HR TEXTRON

HR Textron Inc., a Subsidiary of Textron Inc.

This document has been approved
for public release and may be
distributed as indicated

88 4 7 094

HR TEXTRON

HR Textron Inc.
a Subsidiary of Textron Inc 905 259 4030
25200 West Rye Canyon Road TTX 910 336 1438
Valencia, Calif. 91355-9990 TELEX 65-1492
FSCM NO. 81873

DOCUMENT NO. HR-73300162

HR JCB NO. _____

CONTRACT _____

Page i of 68

DATE January 22, 1986

REV.

1.25 INCH DIAMETER ACTUATOR FINAL REPORT

Accession For	
DTIC GRA&I	<input checked="" type="checkbox"/>
DTIC TAB	<input type="checkbox"/>
Unannounced	<input type="checkbox"/>
Justification	<i>HR</i>
By _____	
Distribution/	
Availability Codes	
Dist	Avail and/or Special
<i>A-1</i>	

This document contains information
the public release of which is
restricted to protect national
defense.

PREFACE

HR was given RFP No. DAAHOI-83-R-0186, 1.25 Inch Diameter Actuator, containing Technical Requirement R0074 and responded with Proposal SEMG-WP-103-138T. This resulted in the award of Contract No. DAAHOI-83-C-0999 containing Attachment I, Technical Requirement R0074 unchanged. The 1.25 Inch Diameter Actuator is intended to control air vanes of a hyper velocity missile containing no warhead but designed to penetrate armored vehicles (tanks, etc.). The Phase I report delineates the HR response to the Technical Requirement R0074. This final report presents the performance data obtained through development testing. This data demonstrates compliance with the aforementioned requirements.

A solenoid spec was written and presented to Orshansky. They manufactured solenoid valves built to this Spec. A preliminary test procedure was prepared to test the components and system. Preliminary actuator drawings were completed and given to the model shop for fabrication. Preliminary electronic drawings were given to EPG of a previously designed and manufactured two channel PWM controller. This controller was modified for intended use.

The HR design effort encompassed the actuators, gas/hydraulic power source, control electronics, actuator/air vane interface, output shaft seal design, assembly sequence and math model of system. The actuator, as mentioned previously, is hydraulic and is a dual, inline, configuration with one piston driving through the other. The piston assemblies are attached to the air vane shafts through linkage and shaft assemblies. The gas/hydraulic power source consists of a gas bottle, squib valves, regulator valve, oil supply and burst diaphragm.

The control electronics are pulse width modulation driving solenoid valves that control flow into and from the actuator. The actuator/air vane interface is comprised of; the linkage that connects the actuator to the output shafts, the output shaft and the air vane attachment to the shafts. The output shaft seal must protect the interior of the missile control section from the thermal environment created by external air flow friction and the four boost motors (5700°F). The assembly sequence accomplishes the installation of all the aforementioned components/assemblies into the 18" length by 1.25 inch diameter cylinder.

The load/test fixture demonstrates how the actuator shall be mounted in the missile and permits convenient, loaded testing of the actuator.

The math model was used to substantiate predicted system performance.

TABLE OF CONTENTS

Section		Page
1.0	SUMMARY.....	1
2.0	INTRODUCTION.....	5
2.1	Program Objectives.....	5
2.2	Proposed Solution to the Stated Problem.....	5
3.0	DESCRIPTION OF THE CONCEPTS AND THEORY OF OPERATION.....	6
3.1	Pneumatic Actuation System Theory of Operation.....	6
3.2	Hydraulic Actuator System Theory of Operation.....	9
4.0	TECHNICAL APPROACH.....	13
4.1	1.25 Inch Diameter Actuation and Load Fixture Design Requirements.....	13
4.1.1	Load Fixture Preliminary Design.....	19
4.1.2	Phase I Deliverable Items.....	23
4.1.3	Trade-Off Study.....	25
4.1.4	System Preliminary Design.....	29
4.1.5	Dual Actuator Design.....	29
4.1.6	Control Section Design.....	29
4.1.7	Phase II - Detailed Design, Fabrication, and Development.....	33
4.1.8	Update the Design Requirements.....	33
4.1.9	Two Axis Design, Analysis, and Fabrication.....	33
4.1.9.1	Update Actuator Dynamic Analysis.....	33
4.1.9.2	Two-Axis Actuator Detailed Design.....	33
4.1.9.3	Solenoid Valve and Potentiometer Procurement.....	34
4.1.10	Loop Closure Electronics Design, Analysis, Fabrication, and Testing.....	34
4.1.10.1	Loop Closure Electronics Design and Analysis.....	34
4.1.10.2	Loop Closure Electronics Breadboard Fabrication.....	35
4.1.10.3	Loop Closure Electronics Acceptance Tests.....	36
4.1.10.4	Loop Closure Electronics Packaging Study.....	36
4.1.11	Two Axis Actuator Development Test.....	37
4.1.12	Load Fixture Design, Analysis, Fabrication, and Testing.....	37
4.1.13	Two-Axis Actuator Design Verification Test.....	38
4.1.14	Computer Program.....	39
4.1.15	Phase II Deliverable Items.....	39

TABLE OF CONTENTS (Continued)

Section		Page
5.0	TEST RESULTS.....	40
5.1	Static Accuracy.....	40
5.2	Hysteresis.....	43
5.3	Slew Rate.....	43
5.4	Output Waveforms.....	43
5.5	Frequency Response.....	66

LIST OF ILLUSTRATIONS

Figure		Page
1-1	Pneumatic Actuation System.....	2
1-2	Hydraulic Actuation System.....	3
3-1	Schematic - Pneumatic Atuation System.....	8
3-2	Pneumatic Actuation System Closed Loop Schematic....	10
3-3	Loop Closure Electronic Block Diagram.....	11
3-4	Schematic - Hydraulic Actuation System.....	12
4-1	Hysteresis and Static Position Error.....	17
4-2	Estimated Panel Loads.....	18
4-3	1.25 Inch Actuator - Load Test Fixture.....	20
4-4	1.25 Inch Actuator - Radial Loader.....	22
4-5	1.25 Inch Actuator - Spring/Inertial Loader.....	24
4-6	Dynamic Response: 160 in-lbs at 10 Hz HVM - Helium System.....	27
4-7	Effects of a New Torque Arm and System Pressure Drop.....	28
4-8	Preliminary Dual Actuation Design.....	30
4-9	Schematic - 1.25 Inch Actuator Control System.....	31
4-10	Preliminary Control Section Design.....	32
4-11	Solenoid Valve Envelope.....	35
5-1	X Axis Static Accuracy at 0.01 Hz, ± 8 Vdc.....	41
5-2	Y Axis Static Accuracy at 0.01 Hz, ± 8 Vdc.....	42
5-3	Y Axis Hysteresis at 0.01 Hz, ± 8 Vdc.....	44
5-4	X Axis Hysteresis at 0.01 Hz, ± 8 Vdc.....	45
5-5	X Axis Slew Rate, +7.5 Vdc to -7.5 Vdc Command.....	46
5-6	X Axis Slew Rate, -7.5 Vdc to +7.5 Vdc Command.....	47
5-7	Y Axis Slew Rate +7.5 Vdc to -7.5 Vdc Command.....	48
5-8	Y Axis Slew Rate -7.5 Vdc to +7.5 Vdc Command.....	49
5-9	Y Axis Wave Form - Sine Wave at 0.1 Hz, ± 7.5 Vdc....	50
5-10	Y Axis Wave Form - Sine Wave at 1 Hz, ± 7.5 Vdc.....	51
5-11	Y Axis Wave Form - Sine Wave at 10 Hz, ± 7.5 Vdc.....	52
5-12	Y Axis Wave Form - Sine Wave at 25 Hz, ± 7.5 Vdc.....	53
5-13	X Axis Wave Form - Sine Wave at 0.1 Hz, ± 7.5 Vdc....	54
5-14	X Axis Wave Form - Sine Wave at 1 Hz, ± 7.5 Vdc.....	55
5-15	X Axis Wave Form - Sine Wave at 10 Hz, ± 7.5 Vdc.....	56
5-16	X Axis Wave Form - Sine Wave at 25 Hz, ± 7.5 Vdc.....	57
5-17	X Axis Wave Form - Sine Wave at 0.1 Hz, ± 1.33 Vdc...	58
5-18	X Axis Wave Form - Sine Wave at 1 Hz, ± 1.33 Vdc.....	59
5-19	X Axis Wave Form - Sine Wave at 10 Hz, ± 1.33 Vdc....	60
5-20	X Axis Wave Form - Sine Wave at 25 Hz, ± 1.33 Vdc....	61
5-21	Y Axis Wave Form - Sine Wave at 0.1 Hz, ± 1.33 Vdc...	62

LIST OF ILLUSTRATIONS (Continued)

Figure		Page
5-22	Y Axis Wave Form - Sine Wave at 1 Hz, ± 1.33 Vdc.....	63
5-23	Y Axis Wave Form - Sine Wave at 10 Hz, ± 1.33 Vdc....	64
5-24	Y Axis Wave Form - Sine Wave at 25 Hz, ± 1.33 Vdc....	65
5-25	Y Axis, ± 1.33 Vdc ($\pm 2.5^\circ$).....	67
5-26	X Axis, ± 1.33 Vdc ($\pm 2.5^\circ$).....	68

LIST OF TABLES

Table		Page
4-1	Cross Reference.....	14

**1.25 INCH DIAMETER ACTUATOR
FINAL REPORT****1.0 SUMMARY**

HR Textron Inc. had gained experience directly applicable to the 1.25 inch diameter actuator program, as a result of in-house research and development (analytical, and hardware studies). HR Textron Inc. then applied this background experience to conceptual designs of two potential actuation systems that satisfy the requirements of the 1.25 inch diameter actuator. This background experience reduced the risk of designing, building, and developing the actuators and loop closure electronics.

A summary of the Phase I effort is defined as follows:

HR Textron Inc. proposed two potential concepts to satisfy the requirements of the 1.25 inch diameter actuator. The concepts were a pneumatic actuation system and a hydraulic actuation system, and are shown in Figures 1-1 and 1-2.

System sizing and dynamic analysis were conducted to prove the feasibility of both concepts.

A trade off study was conducted and the optimum system selected based on performance, cost, weight, volume, and complexity.

The system chosen was the hydraulic actuation system.

PNEUMATIC ACTUATION SYSTEM

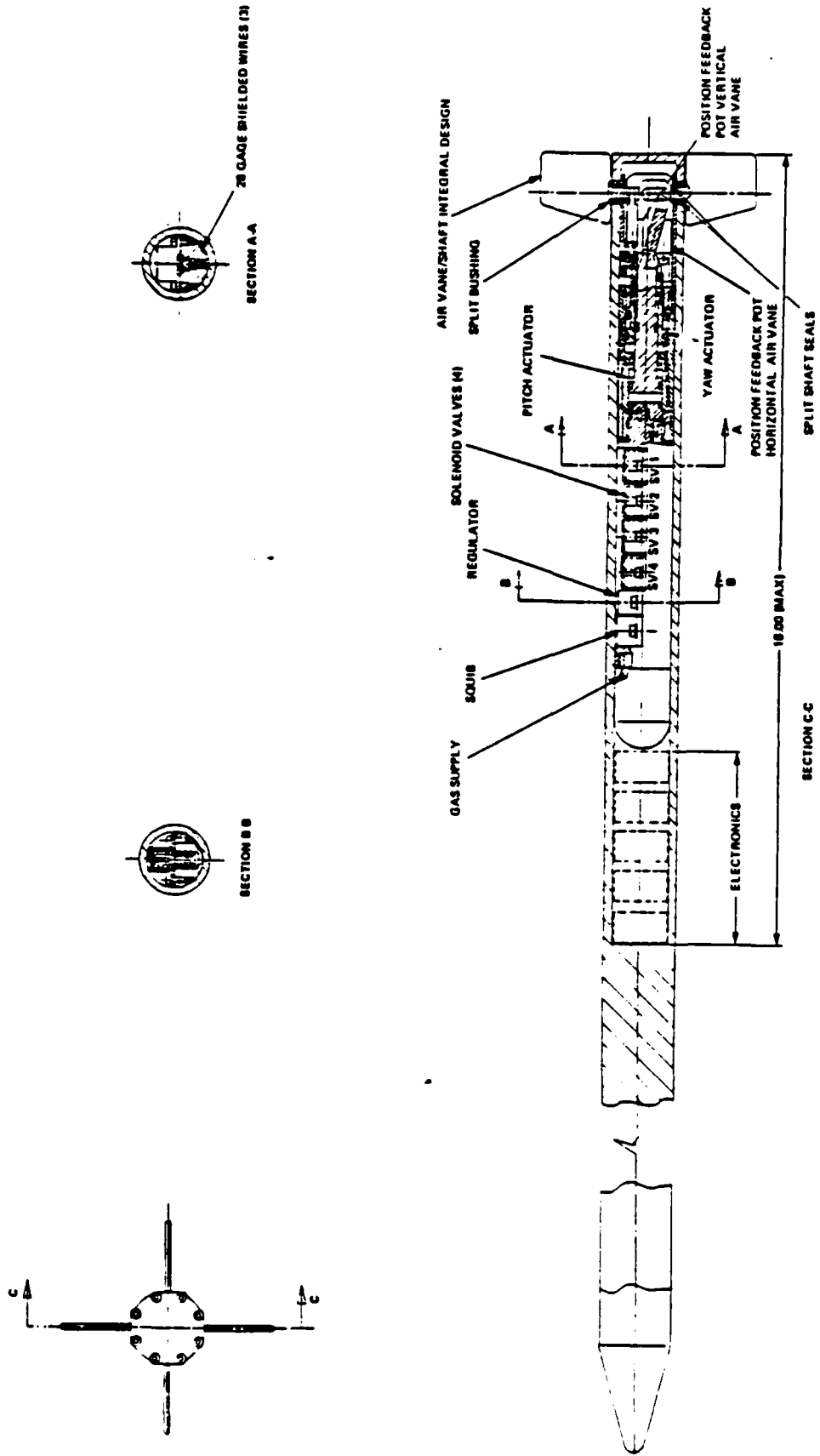

FIGURE 1-1

HYDRAULIC ACTUATION SYSTEM

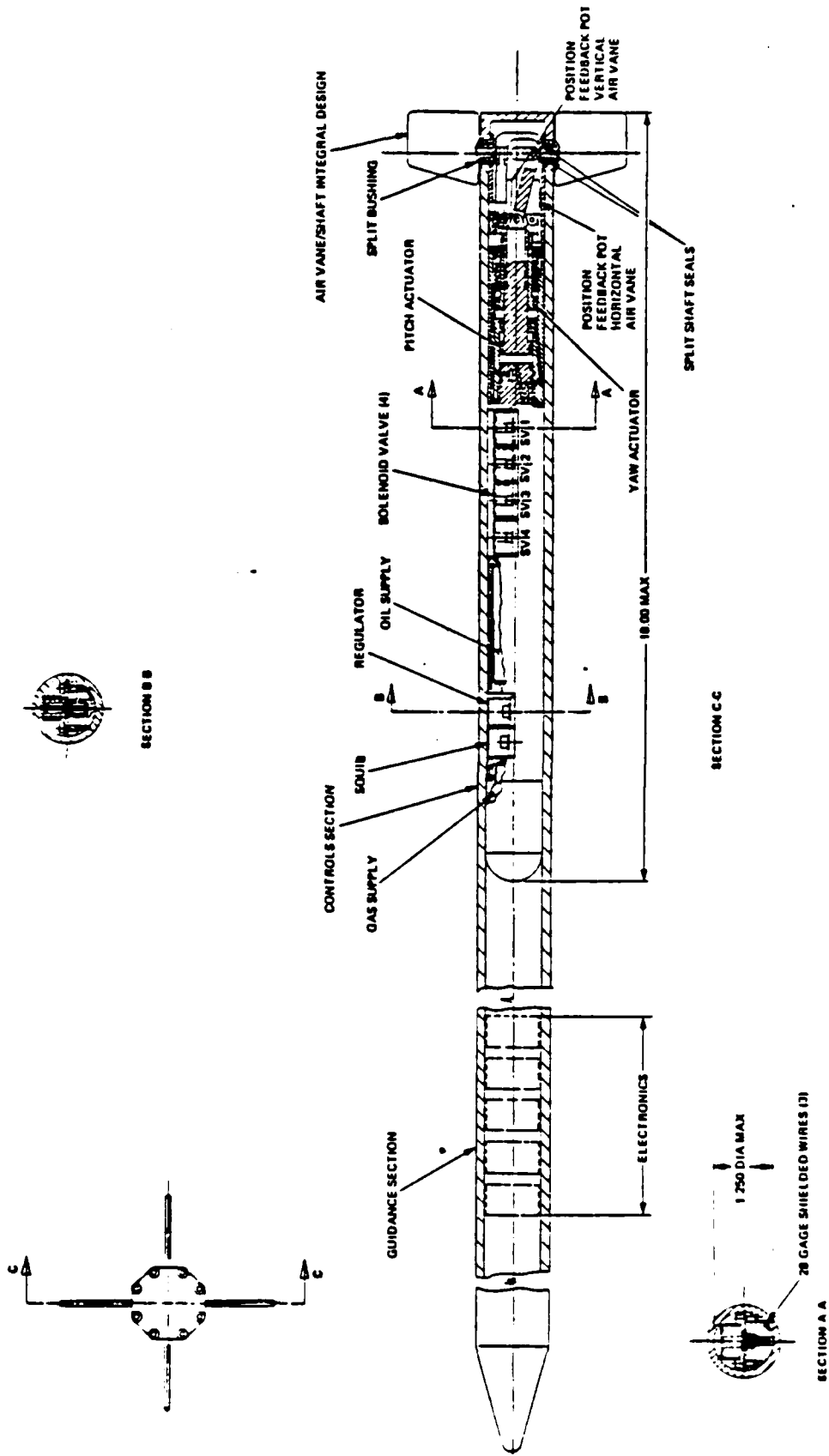

FIGURE 1-2

The selected design concept was utilized to make preliminary designs of a dual actuator and a two axis control system.

A hardware availability study indicated which components were off-the-shelf and which components must be developed.

Experience gained from a study on pulse width modulated loop closure electronics was used as a basis for the preliminary design of the electronics. The components selected during the preliminary design effort have the capability to be miniaturized.

Two load fixture design concepts were evaluated and the best concept used as the basis for the load fixture preliminary design.

A summary of the Phase II effort is defined as follows:

The breadboard loop closure electronics were designed, fabricated, and tested. A packaging study for the two axis loop closure electronics was accomplished.

A dual actuator was designed, fabricated, and development tested. A two axis control section design study was accomplished.

A load fixture was designed, fabricated, and tested.

Design verification tests were conducted on the single actuator with the required loads applied by the load fixture.

HR Textron Inc.'s nonlinear dynamic model of the single actuator was simplified and correlated with the design verification results.

2.0 INTRODUCTION

2.1 Program Objectives

The program defined in the RFP is a two phase effort. The objectives of the two phases are as follows:

Phase I - Perform preliminary design of the actuator, control section concept, and the electrical driving circuits.

Phase II - Perform detailed design, fabrication, and delivery of one prototype actuator with breadboard operating circuits and appropriate load stand.

2.2 Proposed Solution to the Stated Problem

HR Textron Inc. proposed to evaluate two potential control actuation system concepts. The concepts are a pneumatic actuation system and a hydraulic actuation system.

From Figures 1-1 and 1-2 it can be seen that both concepts can be packaged in the required envelope (1.25 inch inside diameter and 18 inches long). Both concepts have a maximum displacement between the pitch and yaw axis of zero (0) inches. The designs permit passage of three (3) number 28 gage shielded wires through the control section.

A trade-off study was conducted and the optimum system selected based on performance, volume, cost, weight, and complexity.

The risk of accomplishing the 1.25 inch diameter actuator program was reduced due to the technical work accomplished by HR Textron Inc. during in-house research and development studies.

3.0 DESCRIPTION OF THE CONCEPTS AND THEORY OF OPERATION

This section contains the concept descriptions and theory of operation for the pneumatic actuation system and the hydraulic actuation system. The descriptions are as follows:

3.1 Pneumatic Actuation System Theory of Operation

The pneumatic actuation system is a low cost precision control system. The system is comprised of two (2) actuators, four (4) solenoid valves, two (2) linear potentiometers, a helium or nitrogen gas bottle, pressure regulator valve, a squib valve, a pressure relief valve,

loop closure electronics, and associated linkages and shafts. Figure 3-1 shows a schematic of the pneumatic actuation system and Figure 1-1 shows the installation of the pneumatic actuation system in the control section envelope. The system is designed to provide air vane control. The operation of the pneumatic actuation system is as follows:

An electrical signal to the squib valve ignites its explosive charge which in turn drives a piston that shears open the gas bottle outlet port. Helium gas is expelled from the gas bottle at 8,000 psi (6,000 psi for nitrogen), and is reduced to 1800 psi (system supply pressure) by the regulator valve. The 1800 psi gas is available on demand by the solenoid valve driven actuators.

The solenoid valves and actuator perform like a conventional "three way valve and double-area actuation system." The double-acting piston is used to drive the air vanes. The rod end of the piston has an effective area of only half of the head end side and is subjected to the full supply pressure (1800 psi) at all times (see Figure 3-1). If the command signal opens the extend solenoid valve, supply pressure enters the head end side of the actuator and the piston extends against the air vane load because of the large area of the head end side of the piston. If the command signal opens the exit solenoid valve, gas is allowed to escape and the piston is retracted by the supply pressure acting on the rod end of the piston.

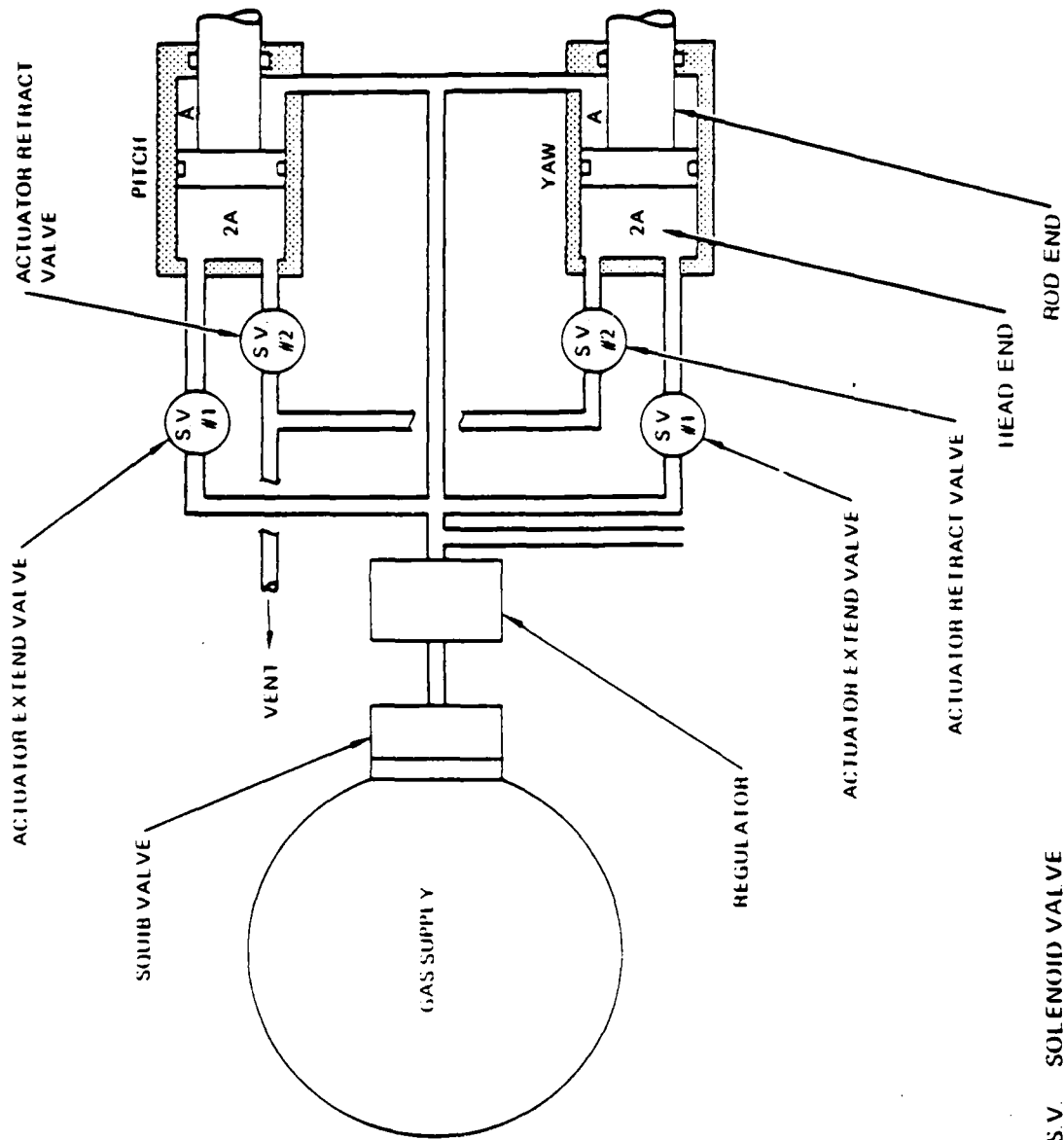

S.V. SOLENOID VALVE

FIGURE 3-1. SCHEMATIC - PNEUMATIC ACTUATION SYSTEM

The pneumatic actuator responds to command position and position feedback signals. These signals are compared and the resulting error is converted to a pulse width modulated signal. A linear potentiometer senses piston position and provides the feedback signal to close the loop (see Figure 3-2). Rate and acceleration feedback are derived by means of passive derivative networks and operational amplifiers. The rate of feedback is used to provide additional stability while the acceleration feedback improves the stiffness. A block diagram of the loop closure electronics is shown in Figure 3-3.

3.2 Hydraulic Actuator System Theory of Operation

Figure 3-4 shows a schematic of the hydraulic actuation system and Figure 1-2 shows the installation of the hydraulic actuation system in the control section envelope. The differences between the pneumatic actuation system and the hydraulic actuation system are as follows:

- o Hydraulic fluid is the fluid medium
- o Supply pressure is 2500 psi
- o Only position feedback is required. (Additional compensation for stability and stiffness are not required.)

The use of hydraulic fluid creates a need for a fluid reservoir. A burst diaphragm is used to contain hydraulic fluid in the system prior to system activation. The operation of the hydraulic actuation system is identical to the operation defined for the pneumatic actuation system.

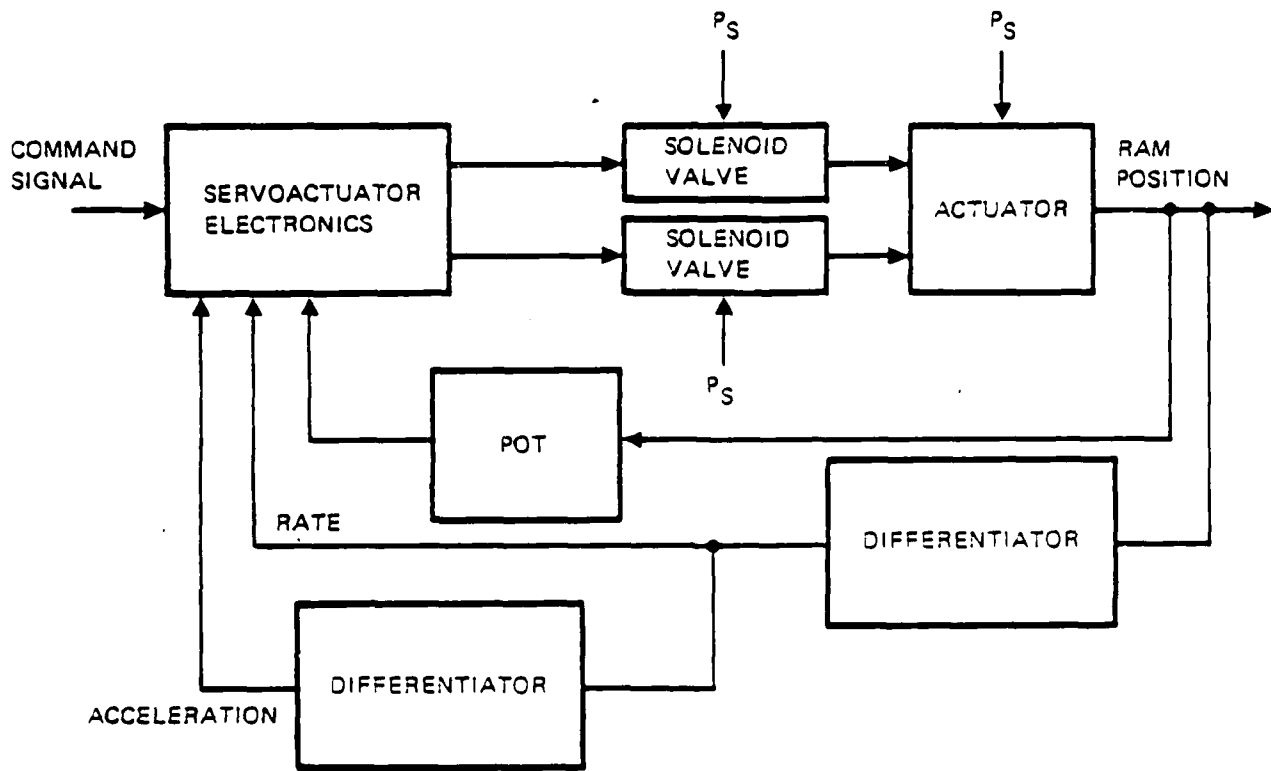

FIGURE 3-2. PNEUMATIC ACTUATION SYSTEM CLOSED LOOP SCHEMATIC

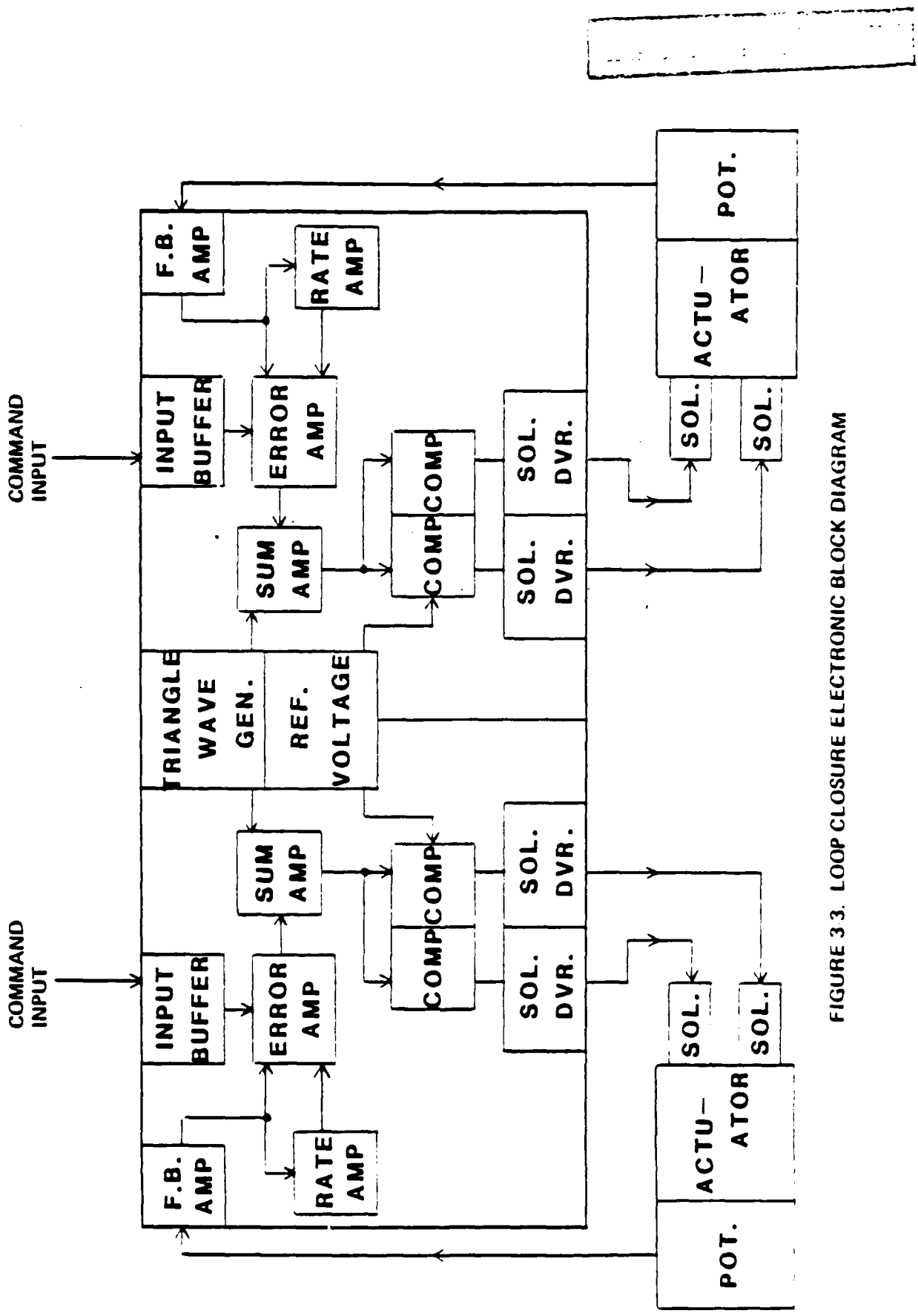
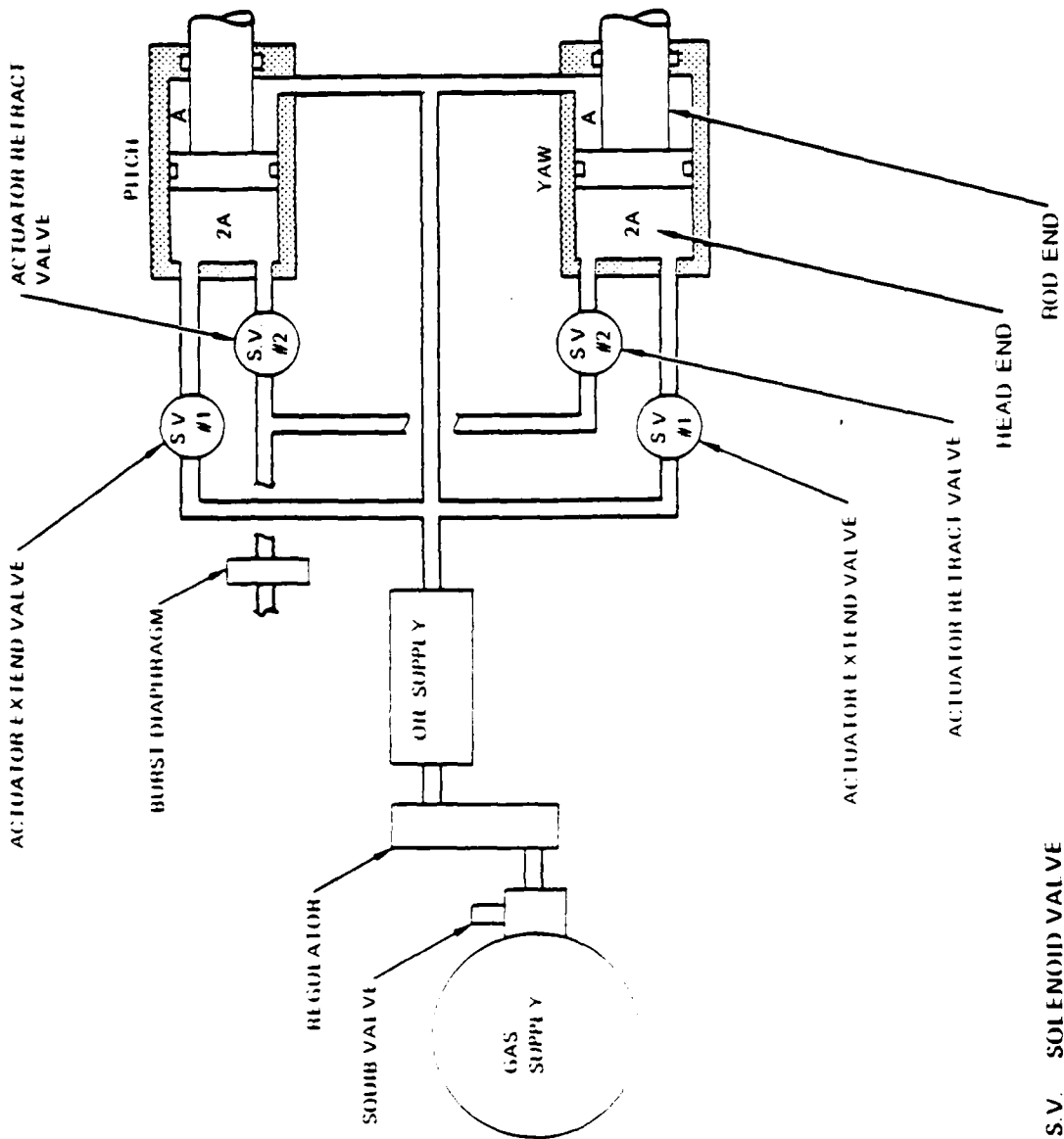

FIGURE 3.3. LOOP CLOSURE ELECTRONIC BLOCK DIAGRAM

Use of this document is subject to the following conditions:



S.V. SOLENOID VALVE

FIGURE 3.4. SCHEMATIC - HYDRAULIC ACTUATION SYSTEM

4.0 TECHNICAL APPROACH

A cross reference between the specification (Attachment I, Technical Requirement R-0074) and this report is shown in Table 4-1.

The intent of this section is twofold:

To demonstrate the technical feasibility of the two actuation system concepts.

To define the system analyses, design, and design verification testing that must be accomplished on the selected actuation system during Phase I and Phase II of the program.

System sizing analyses and system dynamic analyses were accomplished on both actuation system concepts. As shown below these analyses prove the feasibility of both concepts.

4.1 1.25 Inch Diameter Actuation and Load Fixture Design Requirements

The design requirements for the 1.25 inch diameter actuator and load fixture are as follows:

- o Bandwidth; 25 Hz, or greater, when loaded at 6.67 in-lb/deg per axis and input signal level of $\pm 2.5^\circ$.
- o No load slew rate, 400^o/sec minimum.

Table 4-1. Cross Reference

Specification Paragraph Number	Proposal Paragraph Number
SECTION III	
3.1	
3.1.1	4.2.1, 4.2.2.3
3.1.2	4.2.1.3, 4.2.2.3
3.1.3	4.2.1.3, 4.2.2.3
3.1.4	4.2.4
3.1.5	4.2.1.1.3, 4.2.2.1.4, 4.2.2.1.2
3.1.6	4.2.2.1.2
3.1.7	4.3.5.2, 4.3.5.1
3.1.8	4.2.5
3.1.9	4.2.5
3.1.10	4.2.1.3, 4.2.2.3
3.1.11	4.2.1.3, 4.2.2.3
3.1.12	4.2.6
3.1.13	4.2.1, 4.2.2.2
3.1.14	4.2.3
3.2	
3.2.1	4.3.1, 4.3.2, 4.3.2.1, 4.3.2.2, 4.3.2.3
3.2.2	4.3.5, 4.3.5.1, 4.3.5.2, 4.3.5.3
3.2.3	4.3.3.3, 4.3.3.4
3.2.4	4.3.2.4
3.2.5	4.3.7.1
3.2.6	4.3.2.5

Table 4-1. Cross Reference (Continued)

Specification Paragraph Number	Proposal Paragraph Number
SECTION IV	
4.1.a	4.2.1.2, 4.2.2.2.2
4.1.b	4.2.1.2, 4.2.2.2.1
4.1.c	4.2.1.1, 4.2.2.1.1
4.1.d	4.2.1.1, 4.2.2.1.1
4.1.e	4.2.1.2, 4.2.2.2.2
4.1.f	4.2.1.2, 4.2.2.2.2
4.1.g	4.2.5
4.1.h	4.2.1.7, 4.2.2.2.4
4.1.i	4.2.1.1.3, 4.2.1.2.6, 4.2.2.1.3, 4.2.2.1.4, 4.2.2.2.6
4.1.j	4.2.1.2.6, 4.2.2.2.6
4.1.k	4.2.1.3, 4.2.2.3
4.1.l	4.2.1.3, 4.2.2.3
4.1.m	4.2.1.3, 4.2.2.3
4.1.n	4.3.4
SECTION V	
5.1	4.3.4, 4.3.7
SECTION VI	
6.1	4.2.7
6.2	4.3.8

- o Stall torque; 150 inch-pounds per axis desired and 100 inch-pounds per axis required.
- o Deflection; $\pm 15^\circ$
- o Vane inertia; 1.24×10^{-4} lb-in/sec² each or 2.48×10^{-4} lb-in/sec²/axis.
- o Nominal load; 6.67 inch-pounds per degree per axis.
- o Panel loads; as shown in Figure 4-1.
- o Maximum hysteresis and static position error as shown in Figure 4-2.
- o Time of operation; 5 seconds.
- o Duty cycle (each axis): $\pm 15^\circ$ at 2 Hz for 1.0 sec
(2 cycles)
 $\pm 3^\circ$ at 10 Hz for 3.0 sec
(30 cycles)
 $\pm 15^\circ$ at 2 Hz for 1.0 sec
(2 cycles)
- o Diameter; 1.25 inches maximum.
- o Length; 7.0 inches maximum (one actuator)
18.0 inches maximum (2 axis control section)

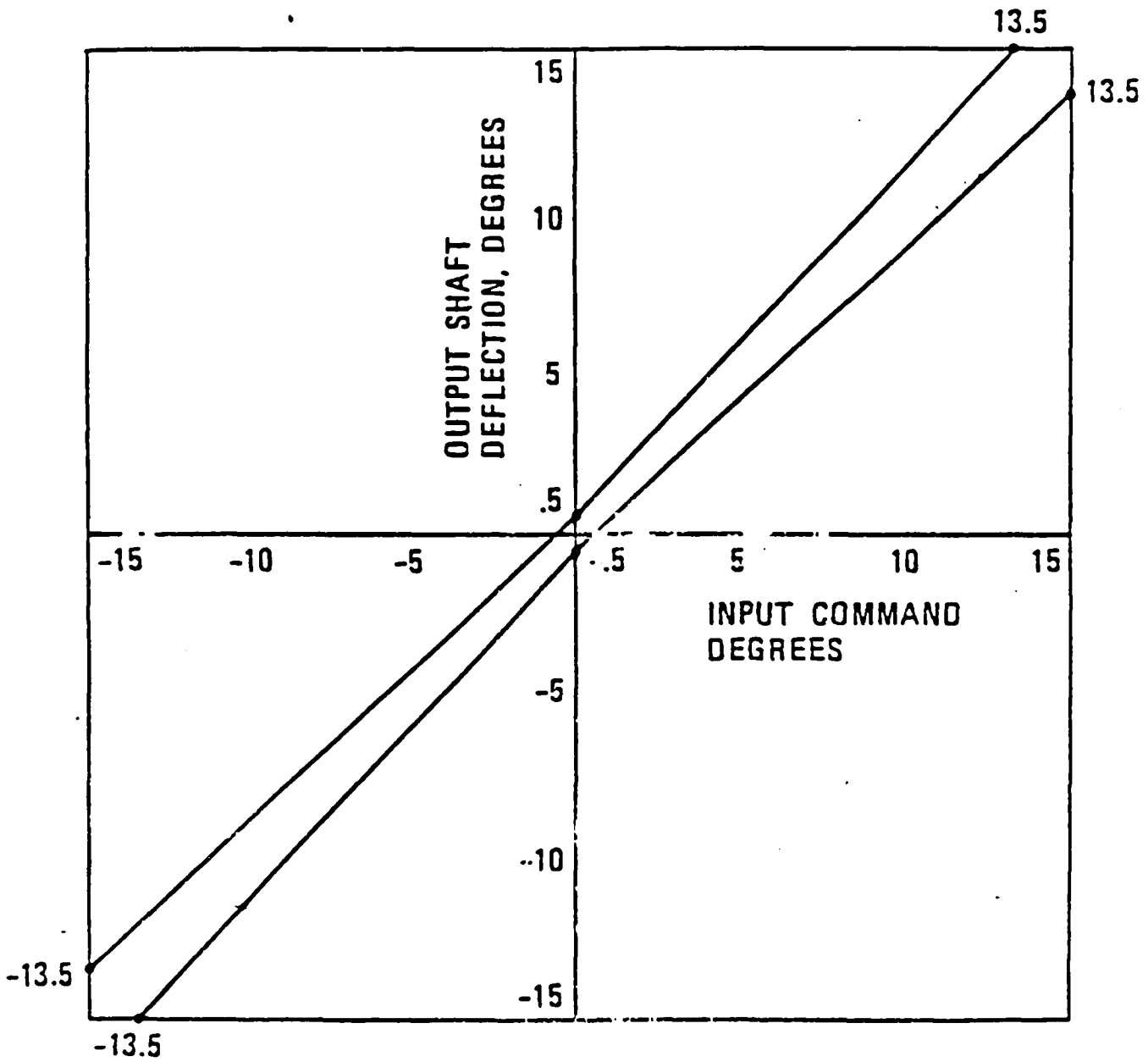

FIGURE 4-1. HYSTERESIS AND STATIC POSITION ERROR

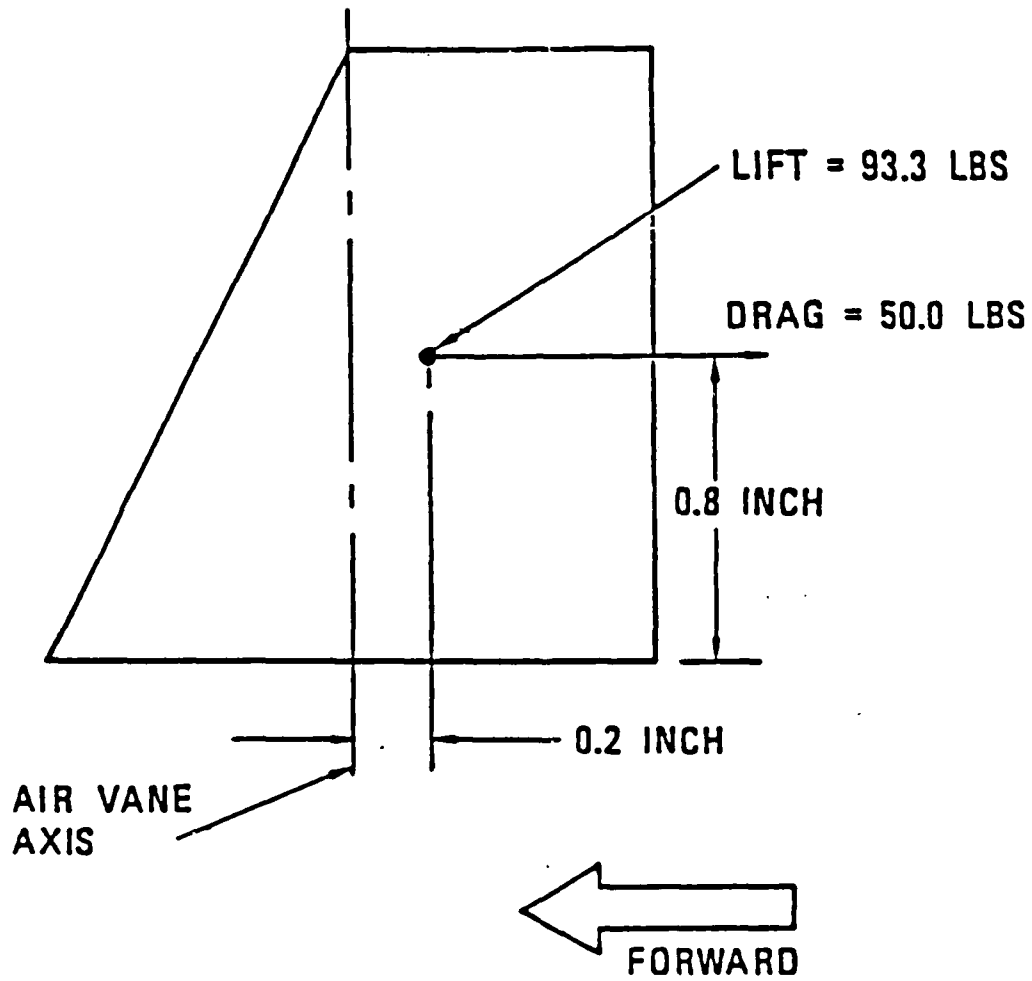

FIGURE 4-2. ESTIMATED PANEL LOADS

- o Weight; 2.0 pounds per actuator.
4.5 pounds per 2 axis control section.
- o Power; 28 volts DC maximum at 10 amps maximum current.

Assembly of the system into the missile is accomplished in the same manner as that employed by the hydraulic system.

Tests on both the hydraulic and pneumatic systems may be performed before assembly into the missile.

4.1.1 Load Fixture Preliminary Design

The 1.25 Inch Actuator load fixture design incorporates three types of loading. The load fixture will consist of a base for mounting, the test actuator, and a torsional, inertial, and radial load module which will attach directly to the test actuator. A dc pot attached to the base and connected to the rotating part of the torsion spring will be used to measure control surface shaft rotation angle. The modular design will enable all four control surface shafts to be loaded by attaching four load modules. A layout of the fixture base with two load modules attached to the test actuator are shown in Figure 4-3.

The three loads are summarized as follows:

Torsional Load. The required load is 6.67 in-lbs/deg for each axis with a rotational angle of $\pm 15^{\circ}$. There are two load modules per axis so each load module torsion spring will have a spring rate of 3.33 in-lbs/deg

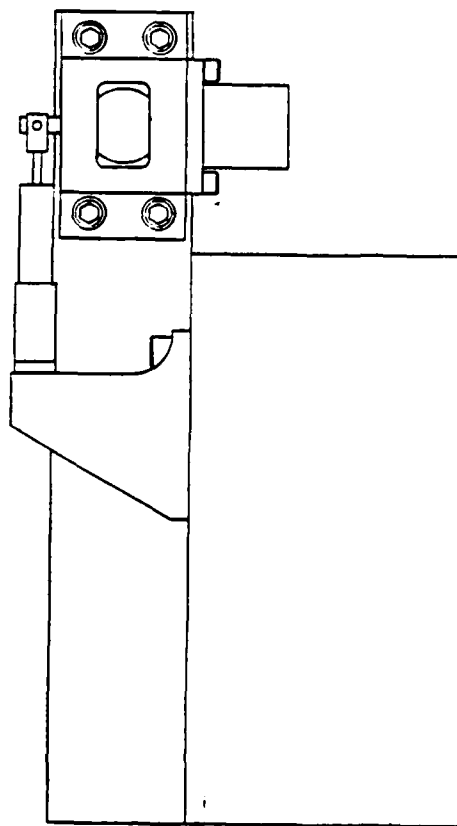
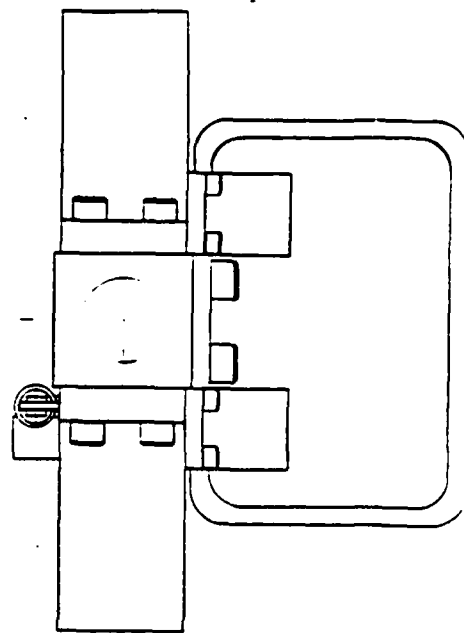
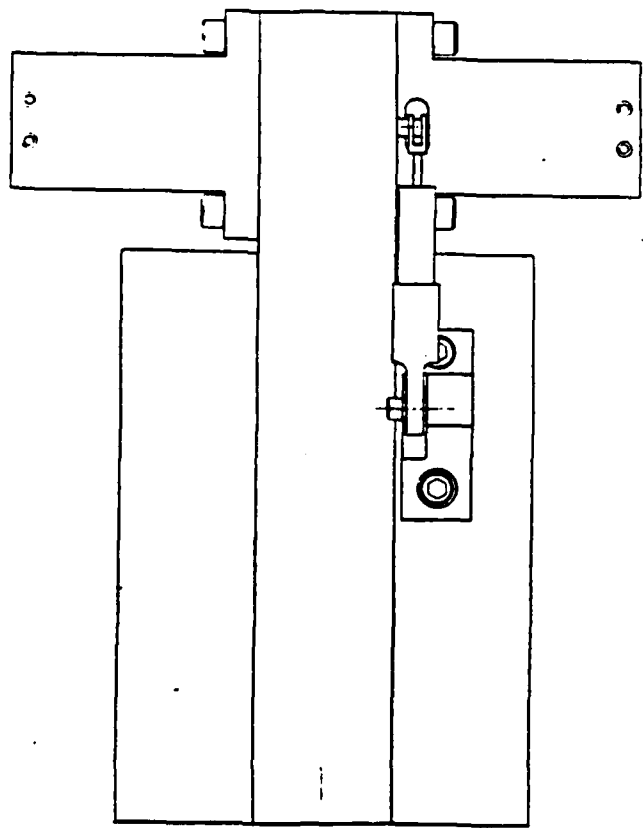

FIGURE 4-3 1.25 INCH ACTUATOR - LOAD TEST FIXTURE

for $\pm 15^\circ$ rotation. The torsion spring was sized based on 100,000 psi stress at full load of 50 in-lbs. The torsion spring diameter becomes 0.137 inch. To obtain the required length the formula

$$\theta = \frac{585 TL}{Gd^4}$$

where

$$\begin{aligned}\theta &= 15 \text{ degrees} \\ G &= 10 \times 10^6 \text{ lbs/in.}^2 \\ T &= 50 \text{ in.-lbs} \\ d &= 0.137\end{aligned}$$

L becomes 1.99 inches. The initial torsion shaft diameter will be 0.140 inches and rate tests conducted to determine the final torsion shaft diameter.

Radial Load. The control surface drag and lift loads were combined to obtain a total radial load of 106 lbs at 0.80 inch from housing per control surface. Each load module will apply 160 lbs 0.8 inch from test actuator housing shaft bearing. The load will be applied with a compression spring rated at 120 lbs per inch and compressed 0.89 inches. The load will be reacted on a bearing pressed on the inertia weight section of the torsion spring. The spring module is shown in Figure 4-4.

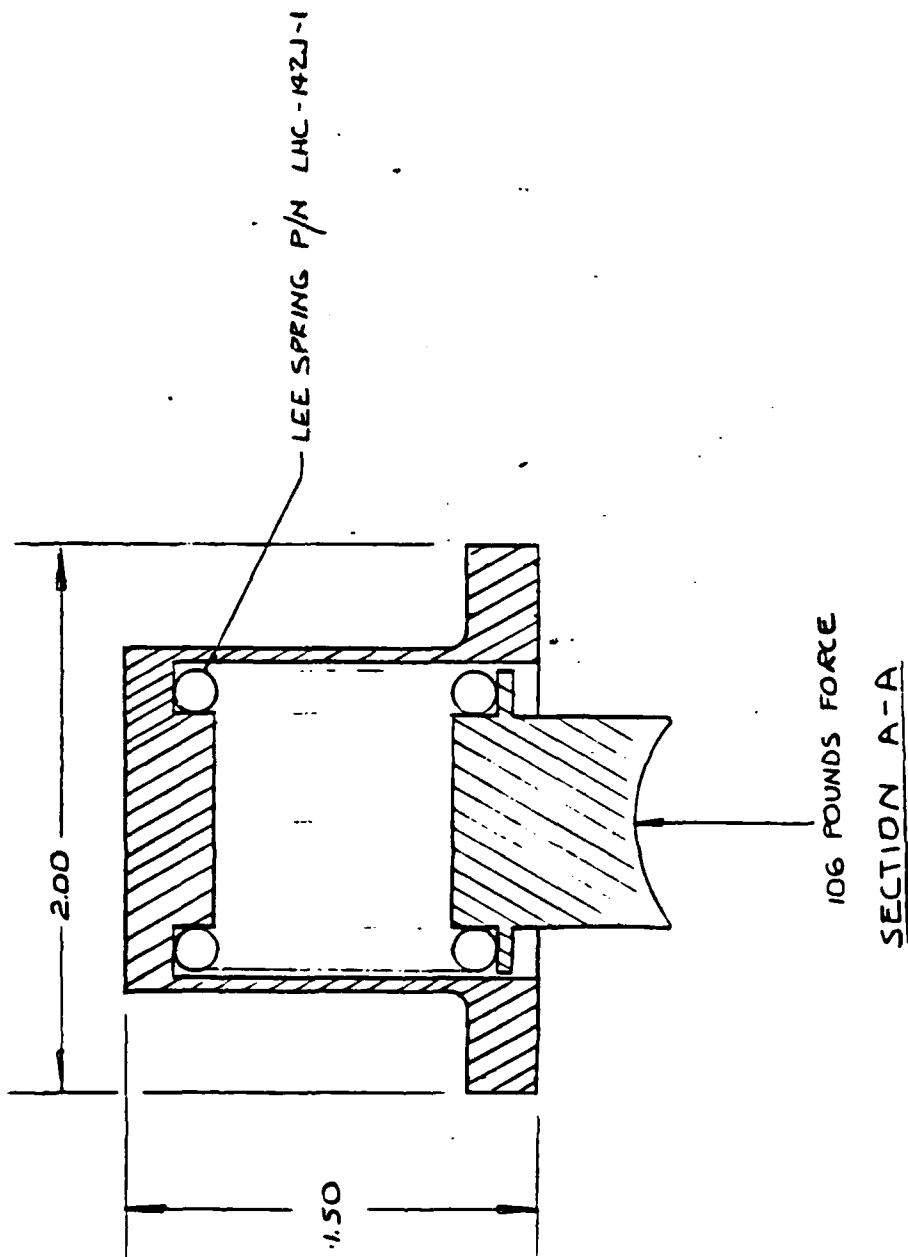
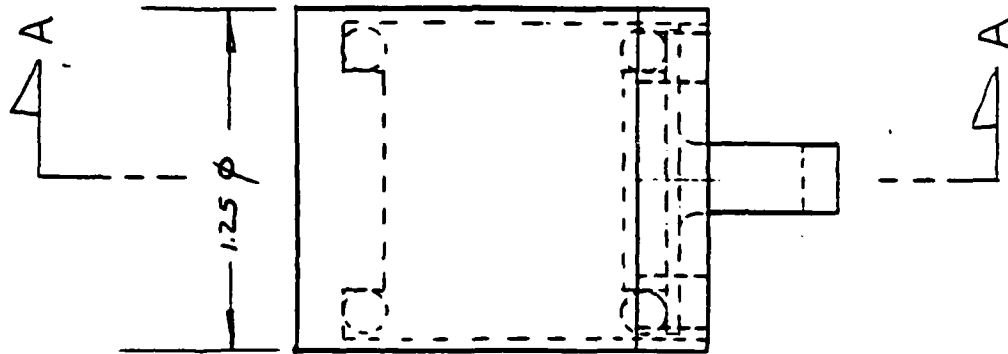

FIGURE 4-4 1.25 INCH ACTUATOR - RADIAL LOADER

Inertia Load. The inertia load requirement is 2.48×10^{-4} lbs-in/sec² per axis. There are two load modules per axis so each load module will include 1.24×10^{-4} lb-in/sec² inertia. The inertia was calculated based on two solid cylinders

$$I = \frac{\pi r^4 m a}{2}$$

and a hollow circular cylinder (the bearing inner race)

$$I = \frac{\pi m a (r_1^4 - r_2^4)}{2}$$

The inertia of the pin for measuring shaft angle was also included. The O.D. of the rotating section of the torsion shaft was sized so the total inertia was 1.24×10^{-4} lbs-in/sec². The inertia/torsion shaft and mount are shown in Figure 4-5.

4.1.2 Phase I Deliverable Items

This report delineates the work that was accomplished to satisfy the Phase I objectives of the 1.25 Inch Diameter Actuator Program.

Performance analyses (actuator static stiffness analyses and the effects of applied load on the control loop position error) were conducted to determine the hysteresis and static position error of the pneumatic and hydraulic actuation system. It was found from these analyses that

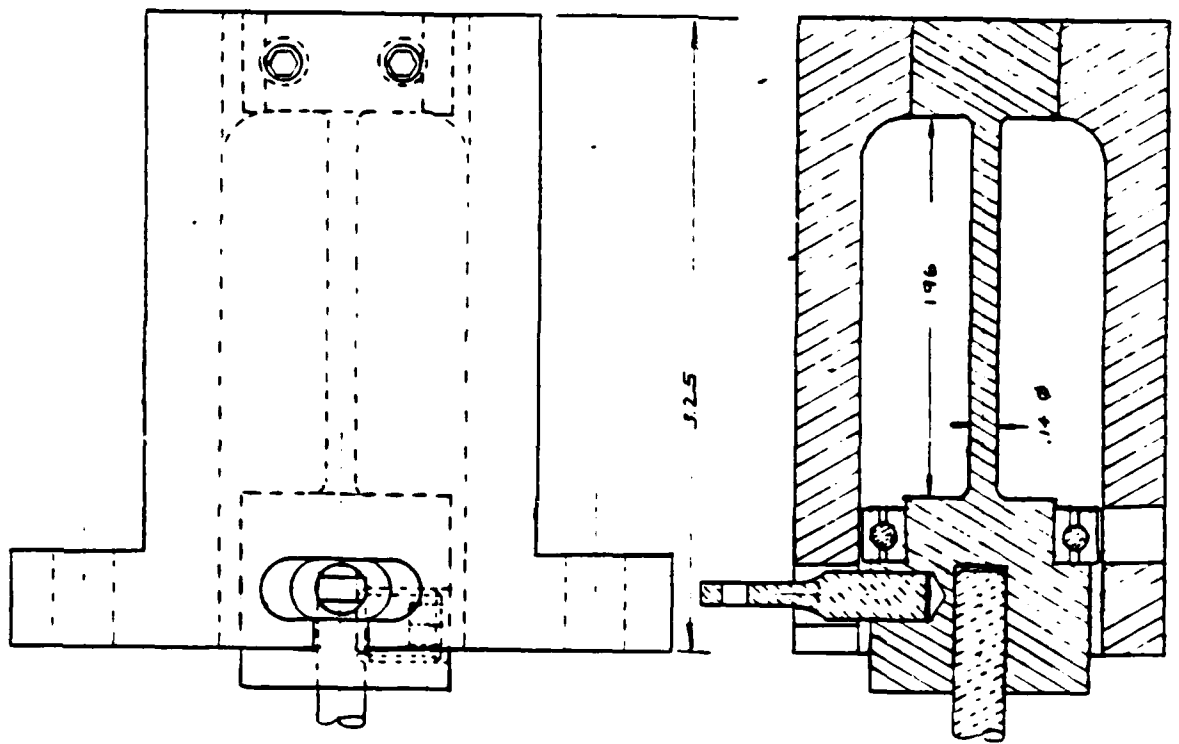
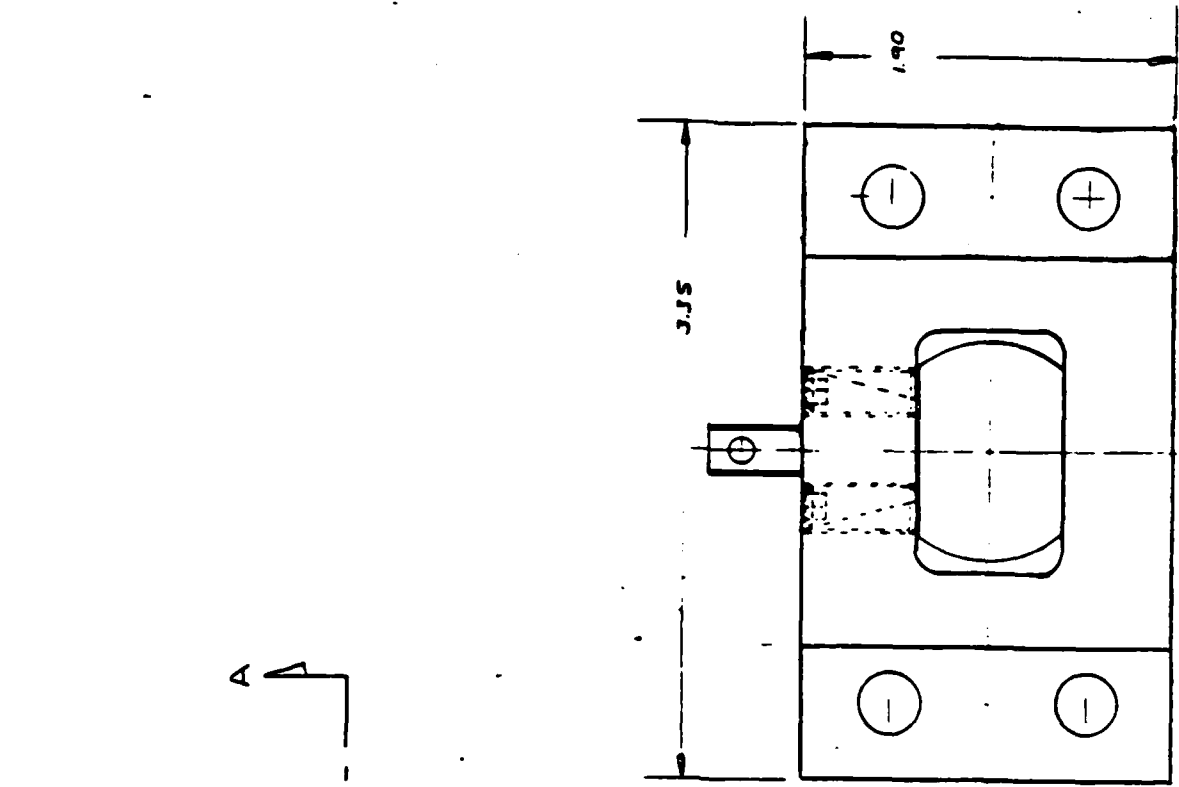

FIGURE 4-5 1.25 INCH ACTUATOR - SPRING/INERTIA LOADER

the hysteresis and static position error design requirement dictated the selection of the optimum actuation system. The results of the analyses indicated that the hydraulic system is the optimum concept.

Design analyses required to accomplish the preliminary design effort are as follows:

- o Flow vs. Pressure Drop Analysis
- o Thermal Analysis
- o Actuator/Control Surface Interface Finite Element Analysis
- o Pressure Regulator Valve Sizing and performance Analyses
- o Electrical Power Usage Analysis

4.1.3 Trade-Off Study

HR Textron proposed two (2) potential control actuation system concepts to satisfy the requirements of the 1.25 Inch Diameter Actuator. The concepts are a pneumatic actuation system and a hydraulic actuation system. System sizing and dynamic performance analyses were conducted to prove the feasibility of both concepts. Additional analyses were accomplished during Phase I of the program to aid in the selection of the optimum concept.

It was found that the design requirement that dictated the selection of the optimum concept is the maximum hysteresis and static position error requirement defined in Figure 4-2.

In order to show compliance of the pneumatic actuation system with the requirement defined in Figure 4-2, two analyses were conducted. The first analysis was a pneumatic actuation static stiffness analysis. The results of this analysis showed that the pneumatic system has a very low static stiffness. The second analysis was conducted utilizing the nonlinear dynamic model and applying a zero signal command to the control loop while applying a 160 pound load at 10 Hz to the control surface. The results of this analysis is shown in Figure 4-6. From Figure 4-6 it can be seen that the position error of the pneumatic actuation system, dictated by its low stiffness, exceeded the static position error requirement.

Based on the above defined analyses and the hydraulic actuator static stiffness analysis, hydraulic actuation system was selected as the optimum system.

During the design effort delineated in paragraph 4.1, the design of the passages and changes in the moment arm lengths required that the system sizing analysis be updated. The results of the sizing analysis is shown in Figure 4-7.

FIGURE 4-6 DYNAMIC LOAD RESPONSE : 160 IN-LBS AT 10 HZ
HUM - HELIUM SYSTEM

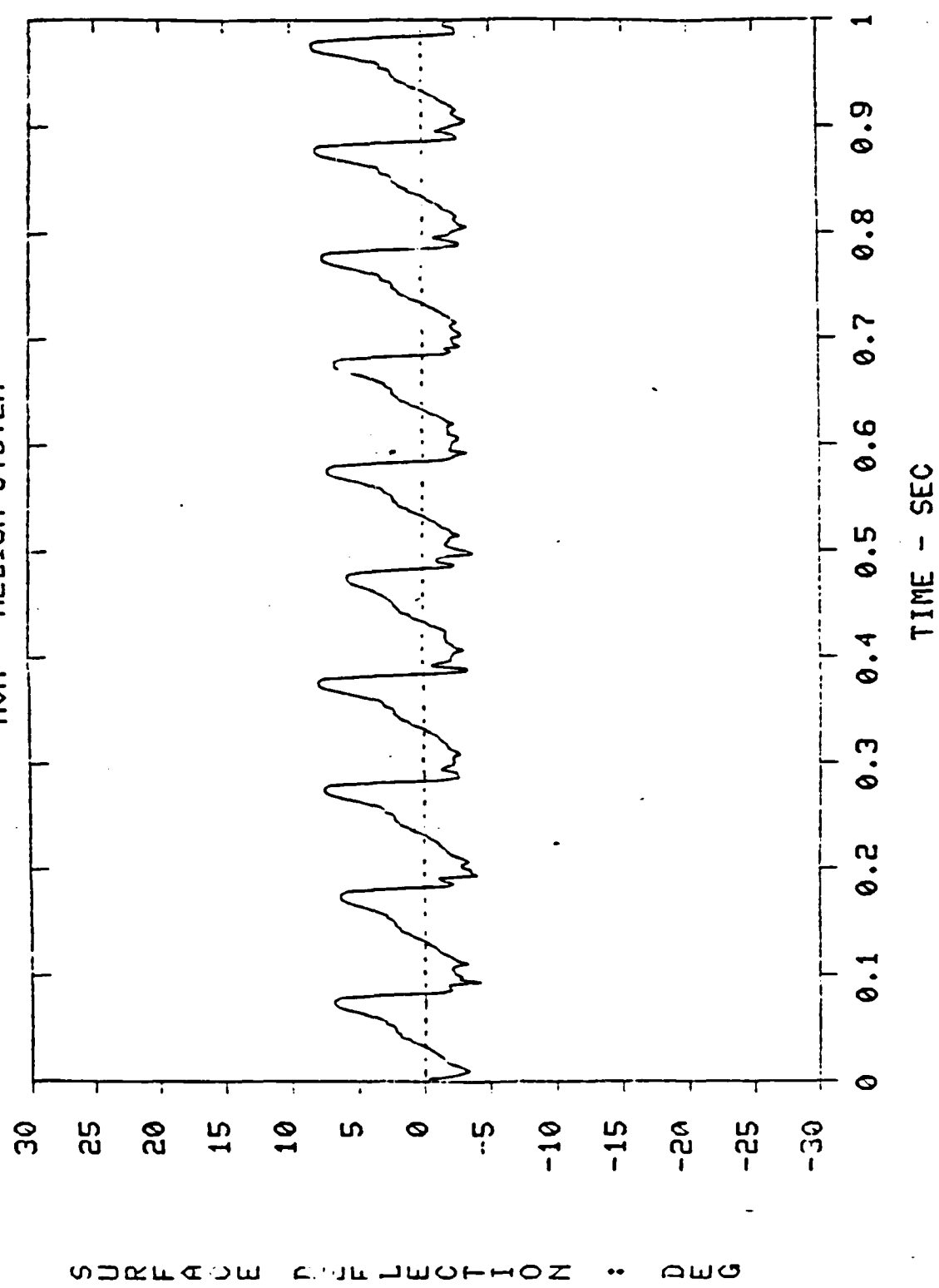

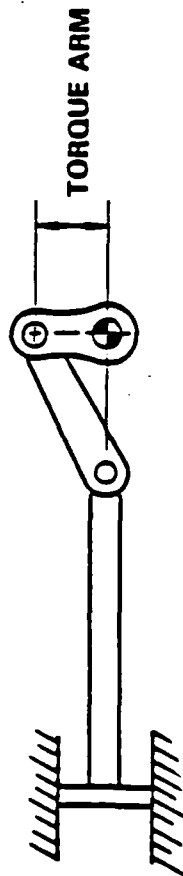

PAGE NO.

	PROPOSAL	PRESENT
TORQUE ARM	0.5 IN	0.4 IN
OIL VOLUME	2.70 IN ³	2.18 IN ³
GAS VOLUME	1.66 IN ³	1.80 IN ³
HYDRAULIC PRESSURE	2000 PSI	2500 PSI
GAS END PRESSURE	2200 PSI	2700 PSI
SOLENOID FLOW AREA	0.00058 IN ²	0.00045 IN ²

FIGURE 4-7 EFFECTS OF A NEW TORQUE ARM AND SYSTEM PRESSURE DROP

4.1.4 System Preliminary Design

This section delineates the preliminary design of the dual actuator and the control section. Also described in this section are design analyses accomplished to define operational requirements and to select design dimensions and values.

4.1.5 Dual Actuator Design

The preliminary design of the dual actuator is shown in Figure 4-8. The hydraulic schematic is shown in Figure 4-9.

4.1.6 Control Section Design

A preliminary design of the control section concept is shown in Figure 4-10.

At the end of Phase I, the following items were delivered:

- a. Preliminary design, including analysis, of an actuator to meet the requirements of this document.
- b. Preliminary layout for a two (2) axis control section concept utilizing the proposed actuator(s).
- c. Preliminary layout of appropriate electrical circuits for operating the proposed actuator(s).
- d. Preliminary layout of mounting fixture and load stand for testing the proposed actuator.

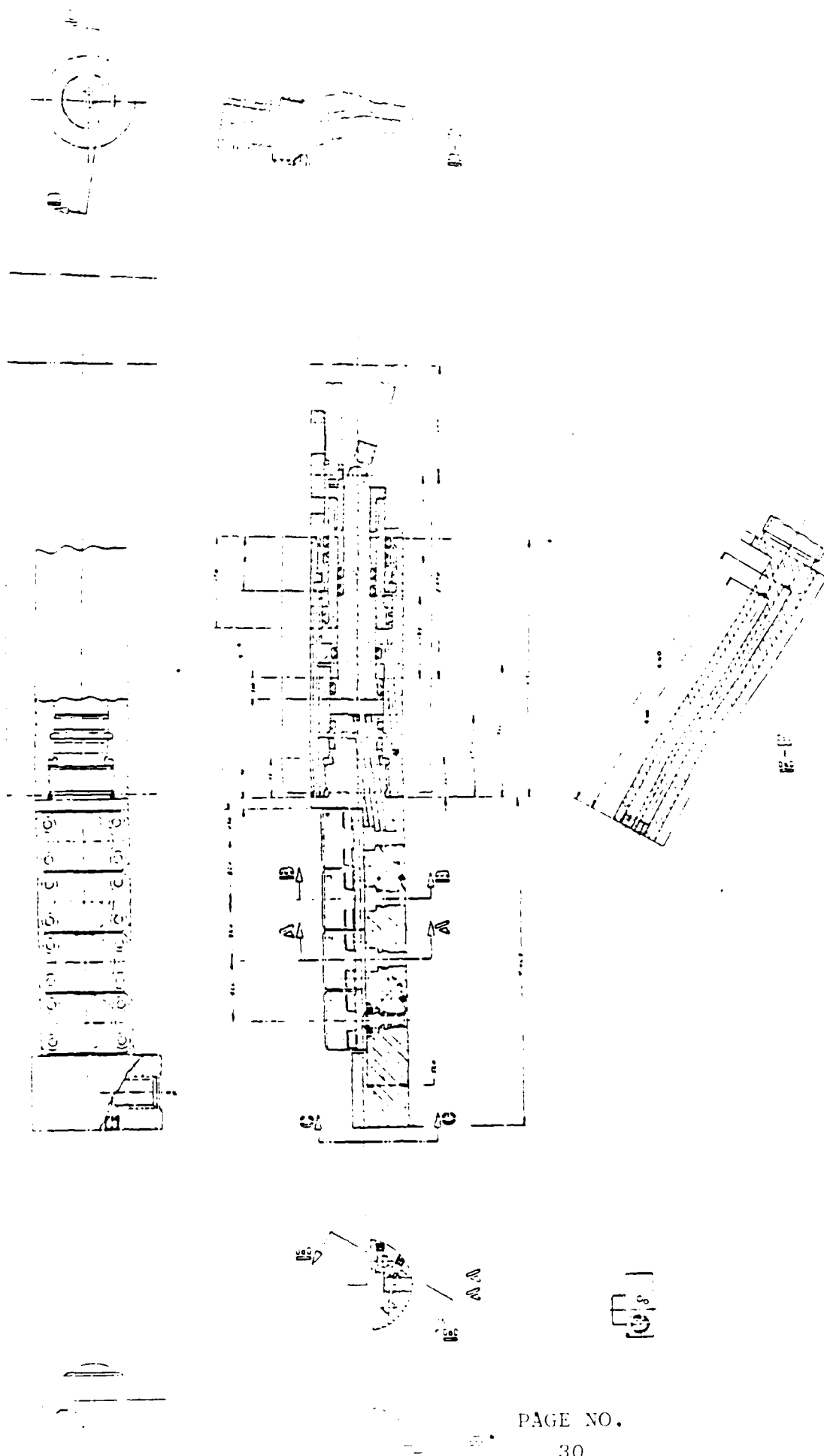

PRELIMINARY DUAL ACTUATOR DESIGN

FIGURE 4-8

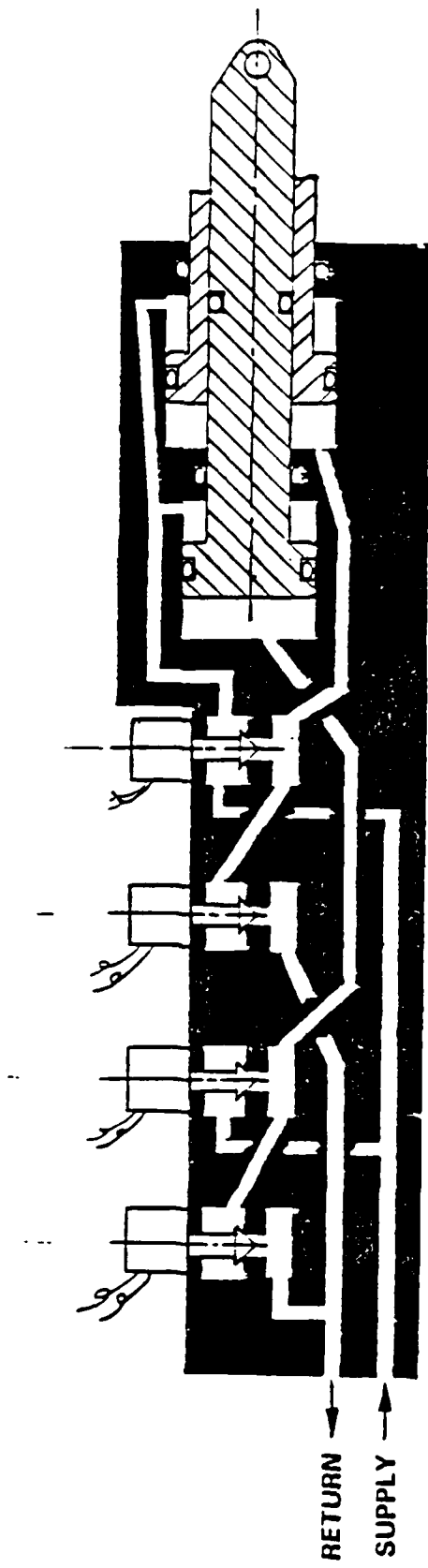
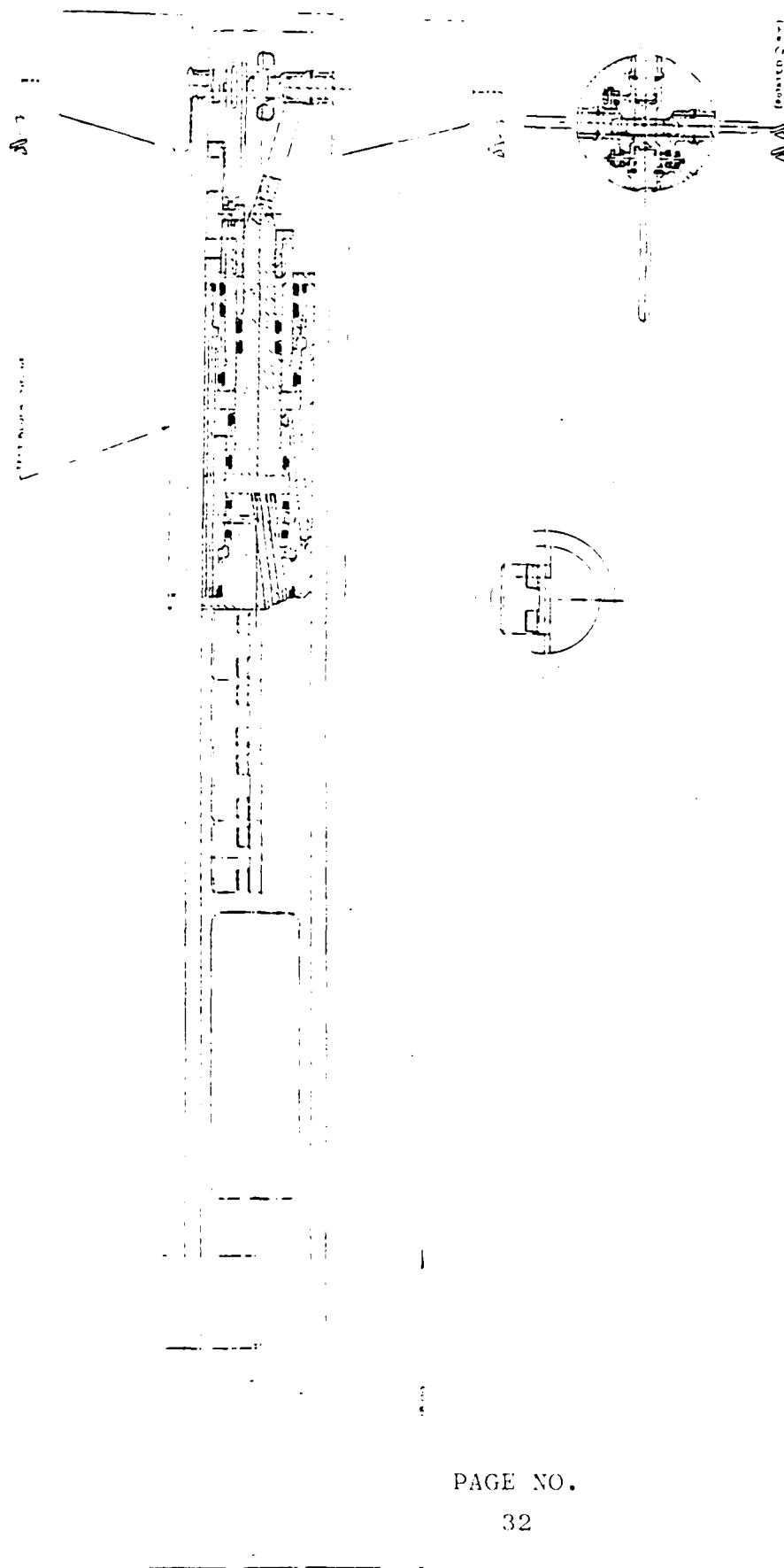

FIGURE 4-9 SCHEMATIC - 1.25 INCH ACTUATOR CONTROL SYSTEM



PRELIMINARY CONTROL SECTION DESIGN

FIGURE 4-10

4.1.7 Phase II - Detailed Design, Fabrication, and Development

During Phase II of the program analysis, detail design, fabrication, and development testing was accomplished on a two-axis prototype actuator and breadboard loop closure electronics. Analysis, design, fabrication, and testing was accomplished on a load fixture. The results of the design verification testing are documented.

4.1.8 Update the Design Requirements

Phase I design requirements were re-evaluated to ensure that they met all of the customer's requirements.

4.1.9 Two Axis Design, Analysis, and Fabrication

4.1.9.1 Update Actuator Dynamic Analysis

If any of the design requirements evaluated were changed, then the analyses affected by the design requirements were updated.

4.1.9.2 Two-Axis Actuator Detailed Design

In order to assure that all of the potential design problems associated with the selected concept are addressed, HR Textron Inc. designed an actuator to fit the 1.25 inch diameter envelope, but packaged in a test block. The solenoid valve manifold is an integral package with the actuator as shown in Figures 1-1 and 1-2.

4.1.9.3 Solenoid Valve and Potentiometer Procurement

4.1.9.3.1 Solenoid Valve Procurement

The preliminary work accomplished by Orshansky Division BMK, Inc. was used to manufacture the solenoid valve, as defined in Figure 4-11. Existing solenoid valve configurations were miniaturized and development testing accomplished.

4.1.9.3.2 Potentiometer Procurement

The potentiometer is a state of the art device that was procured as an off-the-shelf item.

4.1.10 Loop Closure Electronics Design, Analysis, Fabrication, and Testing

4.1.10.1 Loop Closure Electronics Design and Analysis

Based on the results of the Phase I effort, an analysis of the loop closure electronics was performed and the results used to produce the circuit design.

One result of this effort was an estimate of the electrical power requirements for both a single axis system and a dual axis system.

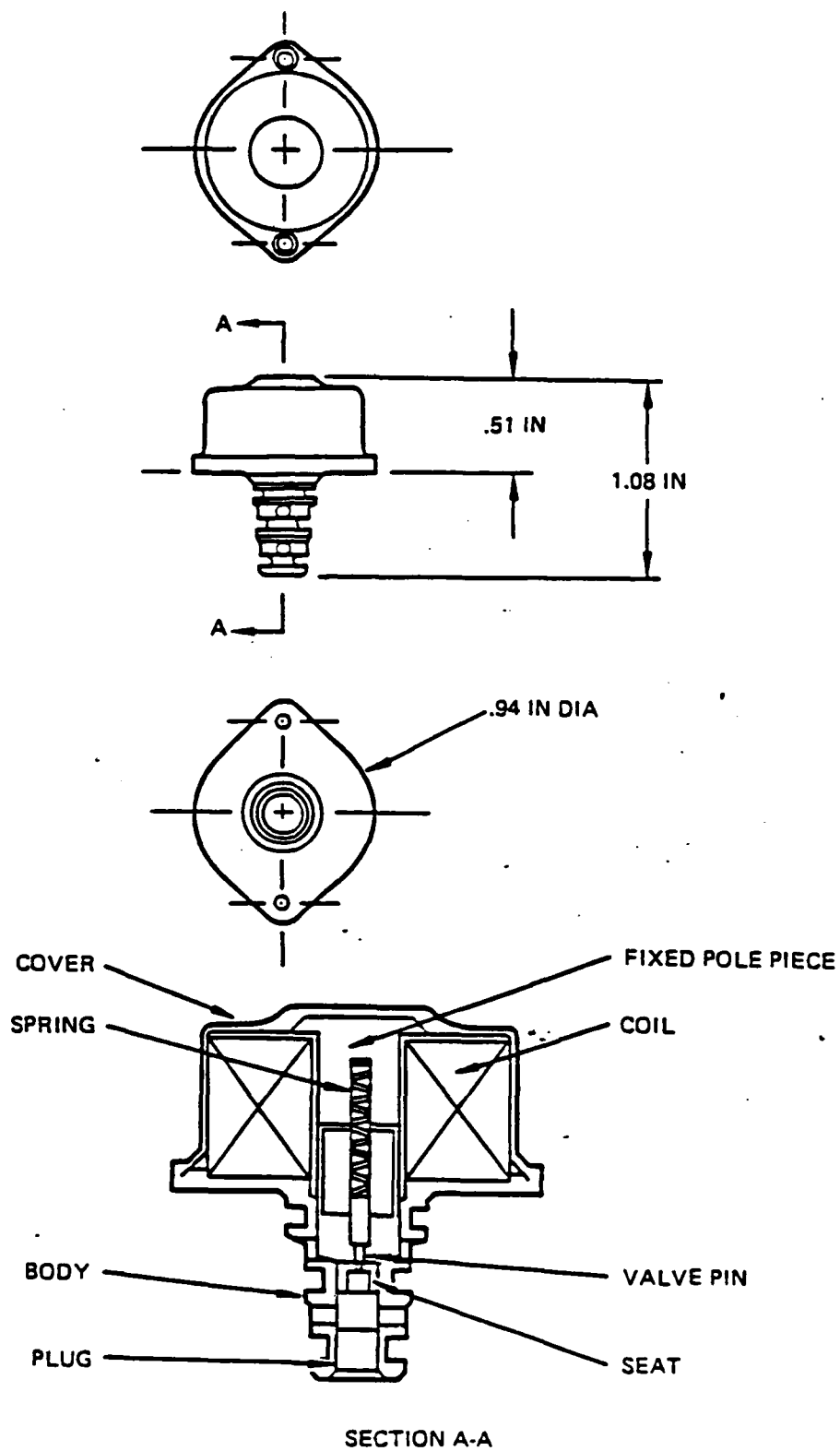

FIGURE 4-11 SOLENOID VALVE ENVELOPE

4.1.10.2 Loop Closure Electronics Breadboard Fabrication

The design established in Paragraph 4.1.10.1 above was implemented as a breadboard model capable of performing all the required functions.

4.1.10.3 Loop Closure Electronics Acceptance Tests

The breadboard model was subjected to the following acceptance tests.

- a. Voltage/current gain
- b. Frequency response
- c. Zero offset
- d. Gain accuracy
- e. Linearity
- f. Input power regulation
- g. Command I/O

These tests were performed under laboratory environment.

4.1.10.4 Loop Closure Electronics Packaging Study

A study was undertaken to optimize the space configuration, employing miniaturization techniques as required, in order to insure compatibility of the space requirements and the available envelope.

4.1.11 Two Axis Actuator Development Test

A development test procedure was written for the testing of the actuators. These tests were conducted on the actuators under loaded and no-load conditions.

Friction tests of the actuators were conducted to determine running and break out friction.

A slew rate test of the actuators was conducted. A square wave command of ± 75 percent of full stroke was applied and both the extend and retract rates were measured.

A closed-loop frequency response for the actuators was conducted. The actuators were tested with a command of $\pm 2.5^\circ$.

A test to determine the accuracy and linearity of the system was conducted. Results are presented in Section 5.0.

4.1.12 Load Fixture Design, Analysis, Fabrication, and Testing

The load fixture is a mechanical system which will provide the specified resistive torques to the actuator. Forces must also be applied which will result in the the same bearing loading as for the air vane.

A detailed layout of the load fixture was made from the Phase I load fixture preliminary layout. Sizing analyses were conducted to define the required load spring rate. A finite element analysis was conducted to assure that no load fixture structural frequencies exist in the actuator bandwidth.

The load fixture was fabricated from the detailed layout.

Design verification tests were conducted on the load fixture to assure that the load fixture as designed will apply the correct load to the single actuator.

The fixture was tested in the following ways:

- a. Steady state loads vs. angle position were determined.
- b. The dynamic loads were determined up to 25 Hz.

4.1.13 Two-Axis Actuator Design Verification Test

The prototype actuator was tested with the load fixture. The objects of these tests are to show the compliance with the specification. A detail test procedure was written and the actuator was tested with the specified load as follows:

- a. Slew rate
- b. Frequency response
- c. Step response
- d. Accuracy and linearity

4.1.14 Computer Program

As previously indicated, HR has a very complete nonlinear system simulation program.

This program was simplified, correlated with test data and is included as one of the deliverable items listed below.

4.1.15 Phase II Deliverable Items

At the end of Phase II, the following items were delivered:

- a. One (1) prototype actuator capable of meeting the performance specified in the technical requirement, complete with breadboarded operating circuits and appropriate load/test stand, and one each spare part of the feedback pot, bearings, and seal as required.
- b. One (1) set of detail drawings, with parts list, of the prototype actuator and load/test stand.
- c. One (1) set of drawings of the electrical driving circuits including a mathematic model, schematic diagrams, wiring codes, etc., as required to operate the actuator(s) from a government-furnished power source.
- d. One (1) updated detailed layout for a two (2) axis control section utilizing the delivered prototype actuator design.

- e. One (1) layout of how the electrical operating circuits would package into a 1.25 inch inside diameter cylinder.
- f. One (1) procedure for safely starting, operating, and stopping the operation of the prototype actuator.
- g. One (1) final report, and other documentation, as defined in Section VII.

5.0 TEST RESULTS

The objective of the test program was to show performance meeting the requirements of specification Technical Requirement R0074. The figures presented herein demonstrate compliance with these requirements.

A secondary purpose of this program has been to prove the worth of a pseudo digital control for a hydraulic (or pneumatic) actuation system. These same figures show little or no deterioration in waveform, amplitude, phase, or accuracy due to the pulse width modulation (PWM)/solenoid mechanization.

5.1 Static Accuracy

Static accuracy for channels X and Y are shown in Figures 5-1 and 5-2. The accuracy is within the required tolerance ($\pm 0.5^\circ$ at zero command and $\pm 1.5^\circ$ at $\pm 15^\circ$ command). The PWM "steps" have little affect upon the waveform.

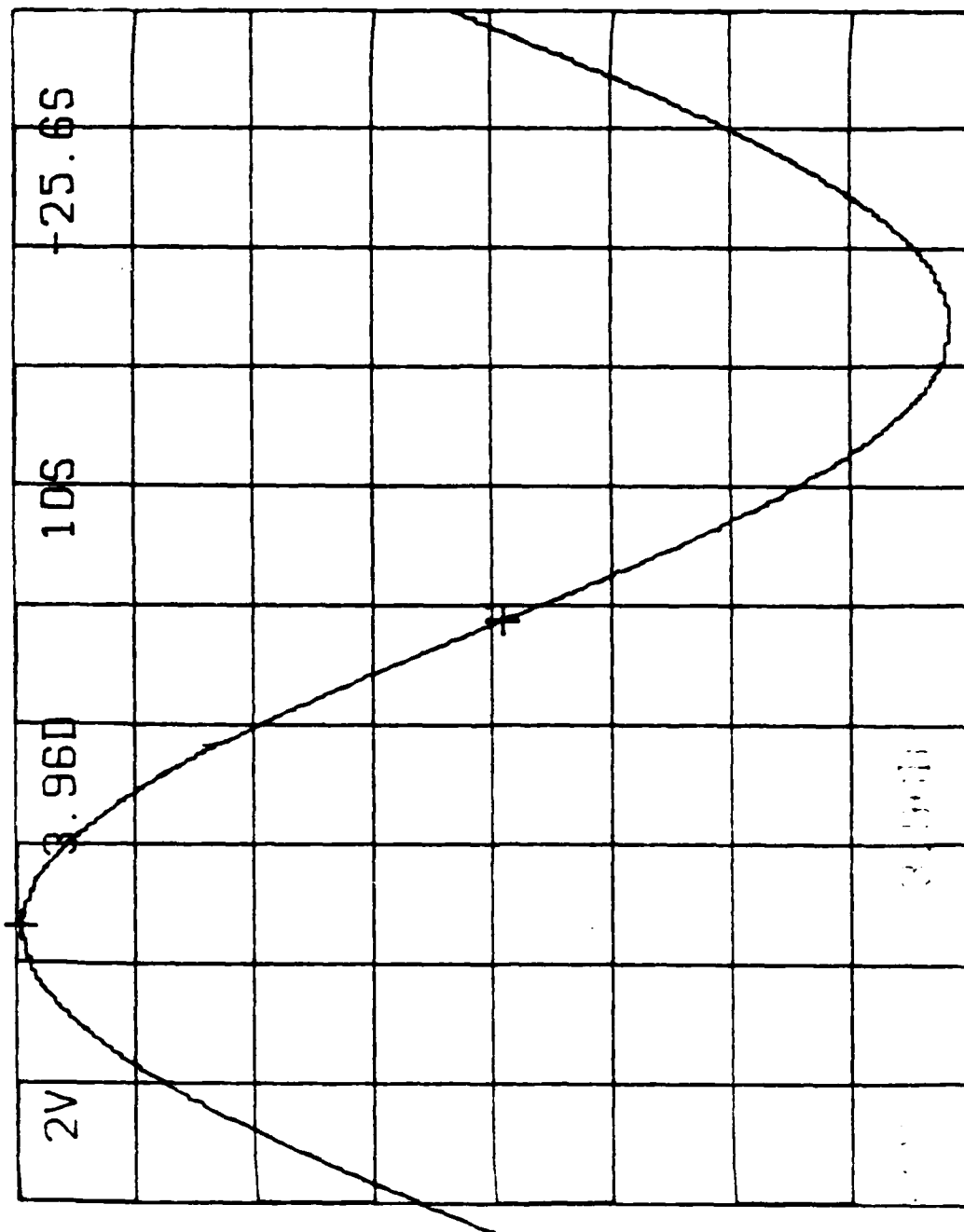

X AXIS STATIC ACCURACY @ .01 HZ, ±8VDC
 FIGURE 5-1

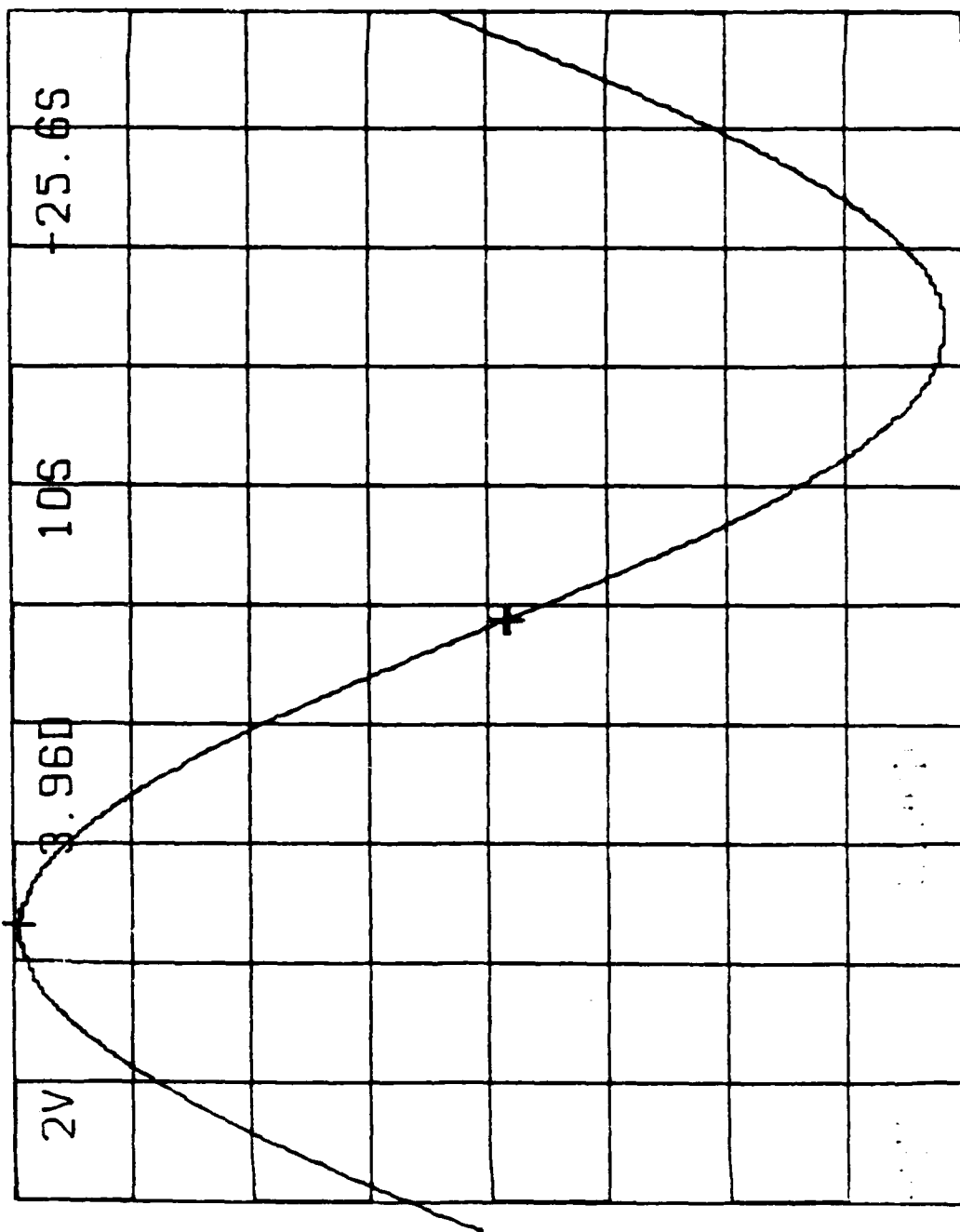

PAGE NO.

42

Y AXIS STATIC ACCURACY @ .01 HZ, ±8VDC

FIGURE 5-2

5.2 Hysteresis

Hysteresis plots shown in Figures 5-3 and 5-4 demonstrate compliance to specification (same tolerance as static accuracy).

5.3 Slew Rate

The slew rates for channel X are shown in Figures 5-5 and 5-6. The slew rates for channel Y are shown in Figures 5-7 and 5-8. The slew rates range between 500° per second and 1000° per second for a full-scale command ($\pm 14^{\circ}$ to $\pm 14^{\circ}$). Specification requirements is 400° /second.

5.4 Output Waveforms

Figures 5-9 through 5-24 depict actuator output waveforms for both the X and Y axes actuators. The demonstration frequencies chosen are 0.1, 1, 10, and 25 Hz. The amplitudes shown are ± 7.5 Vdc ($\pm 14^{\circ}$) and ± 1.33 Vdc ($\pm 2.5^{\circ}$).

Full-scale (large signal) commands are shown in Figures 5-9 through 5-16. The gain and phase responses are graphically shown as the frequency is varied from 0.1 Hz to 25 Hz. It should be noted that the actuator is slew rate limited above approximately 10 Hz.

The next series of waveforms are run with small signal commands (± 1.33 Vdc, $\pm 2.5^{\circ}$). (Figures 5-17 through 5-24.)

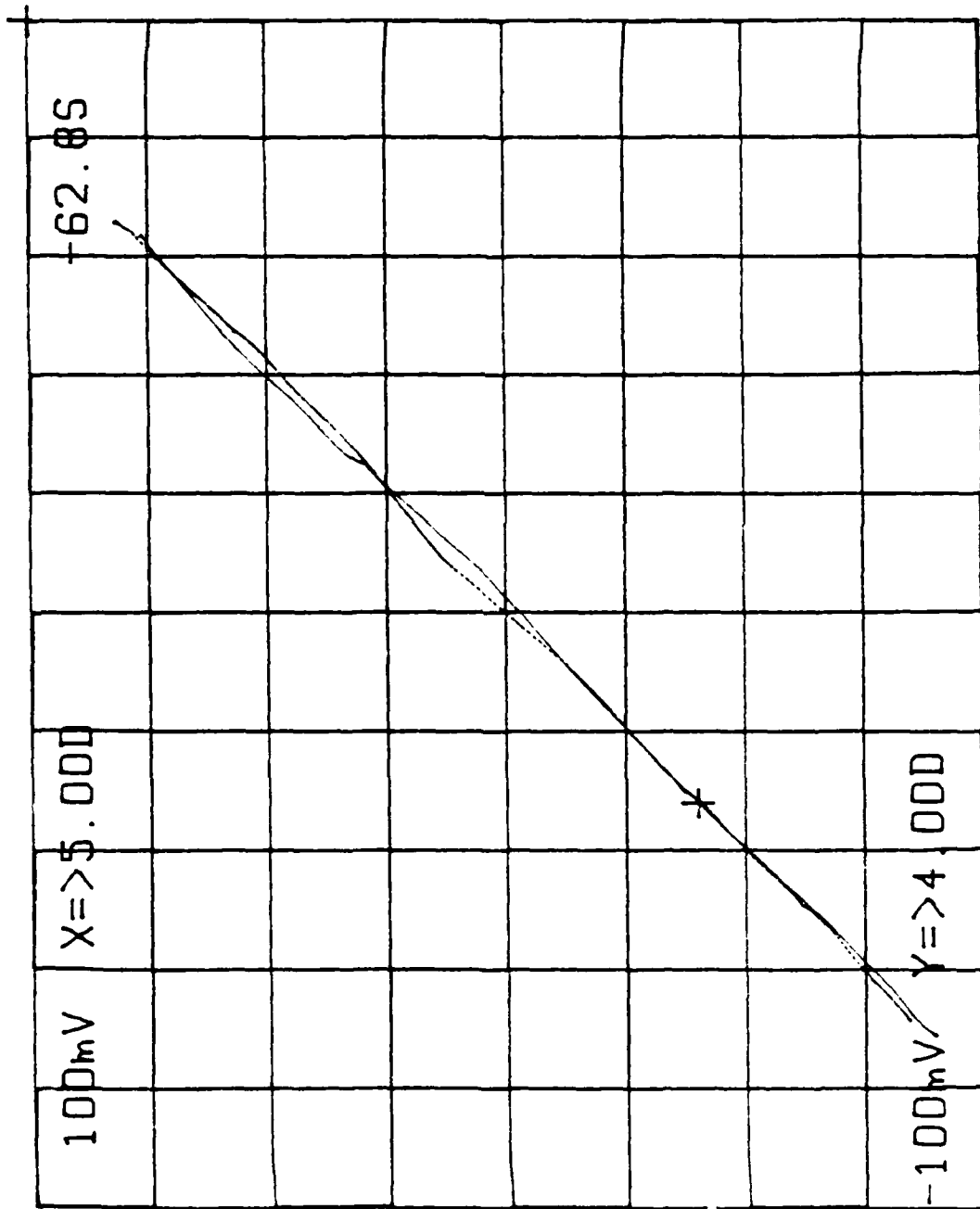

Y AXIS HYSTERESIS @ .01 HZ, ±8VDC

FIGURE 5-3

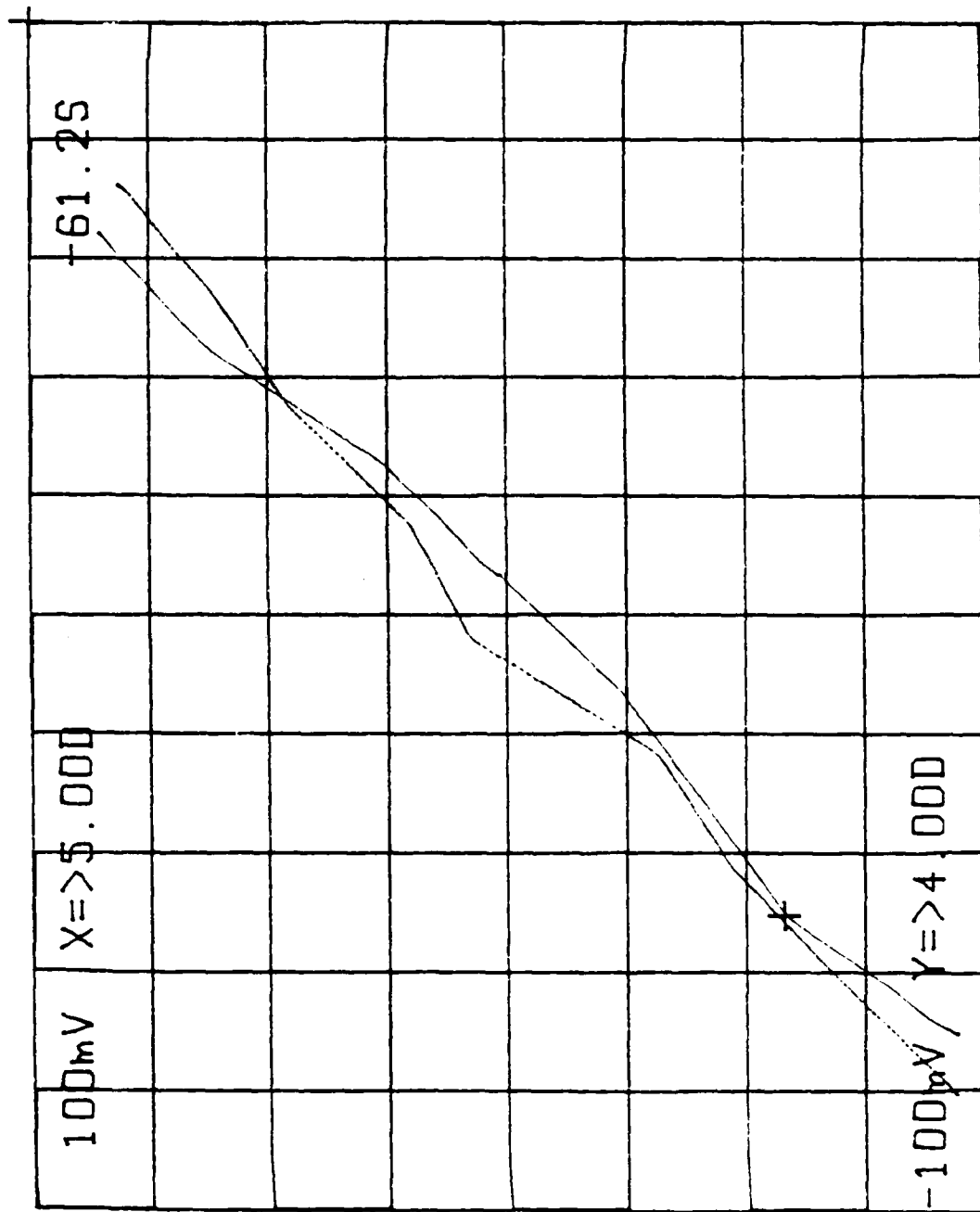

X AXIS HYSTERESIS @ .01 HZ, ±8VDC

FIGURE 5-4

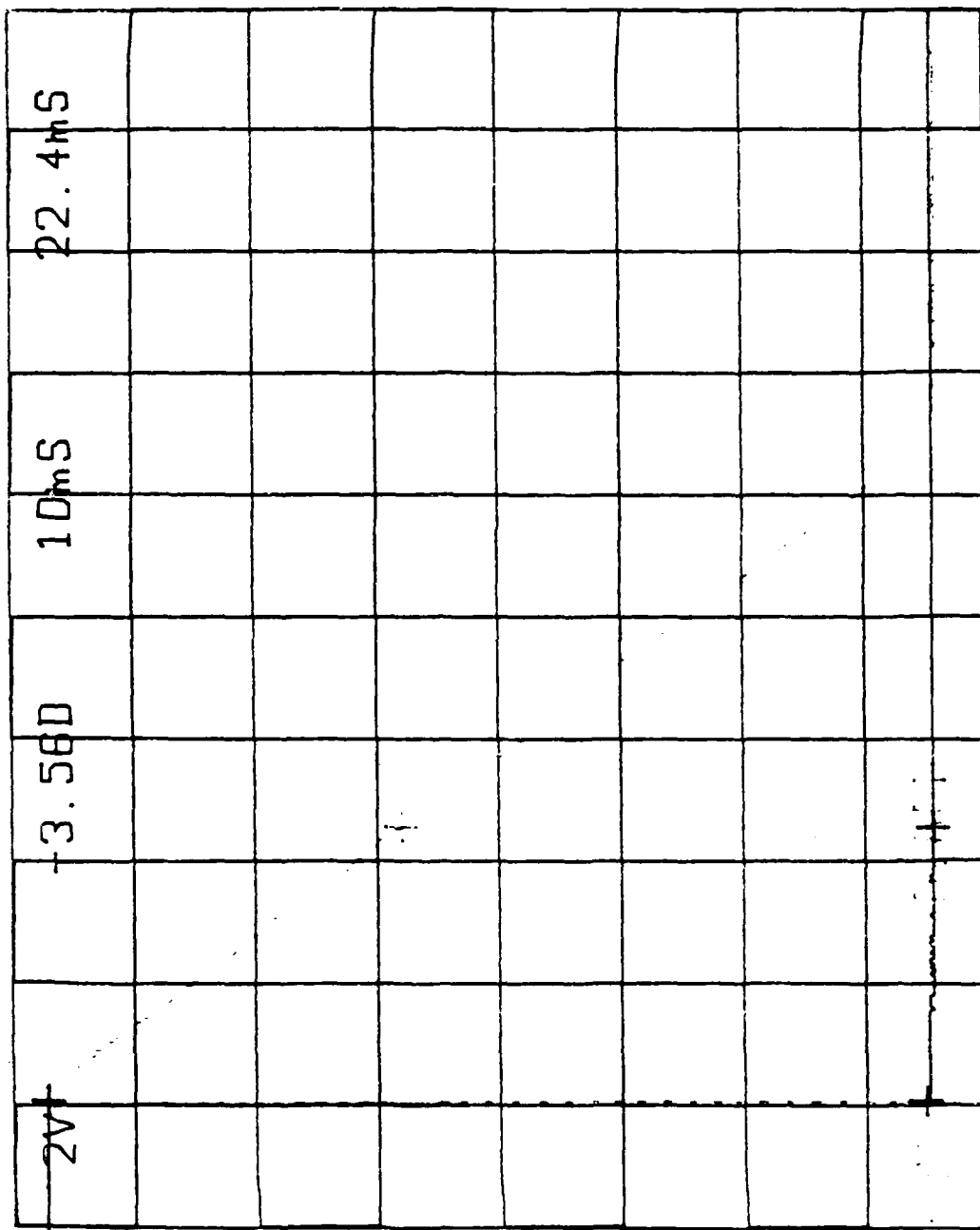

X AXIS SLEW RATE, PLUS 7.5 VDC TO MINUS 7.5 VDC COMMAND

FIGURE 5-5

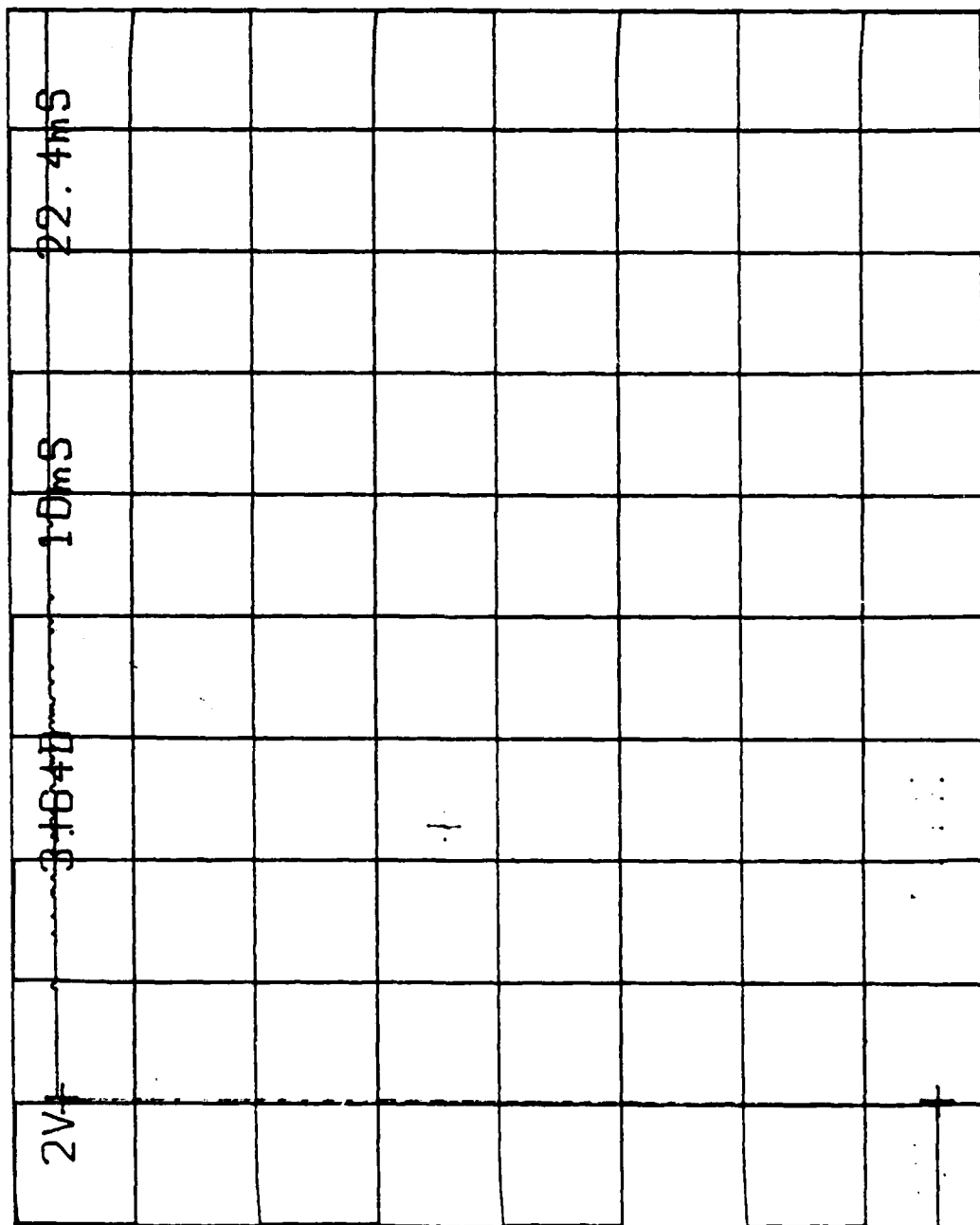

X AXIS SLEW RATE, MINUS 7.5 VDC TO PLUS 7.5 VDC COMMAND
 FIGURE 5-6

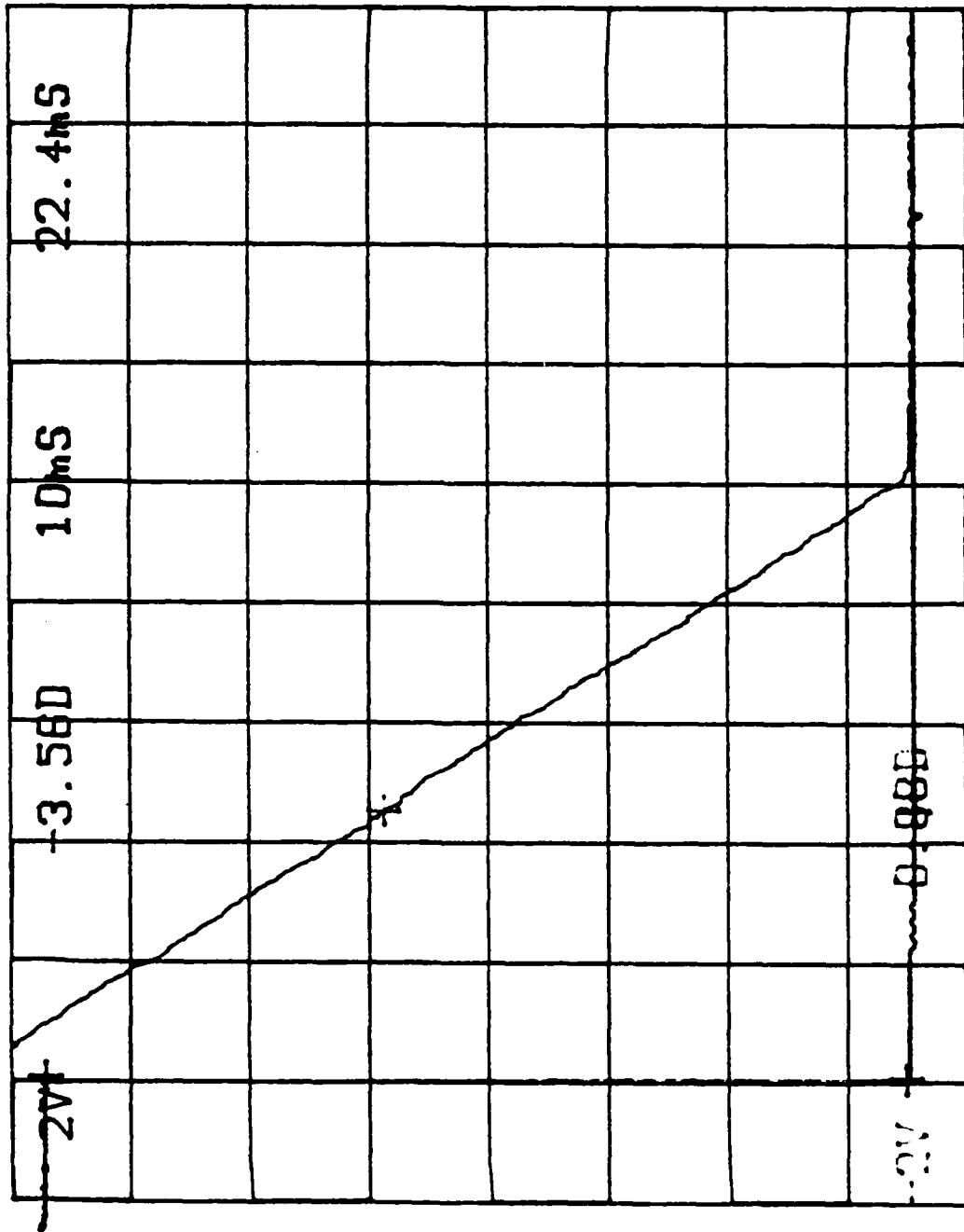

Y AXIS SLEW RATE, PLUS 7.5 VDC TO MINUS 7.5 VDC COMMAND
 FIGURE 5-7

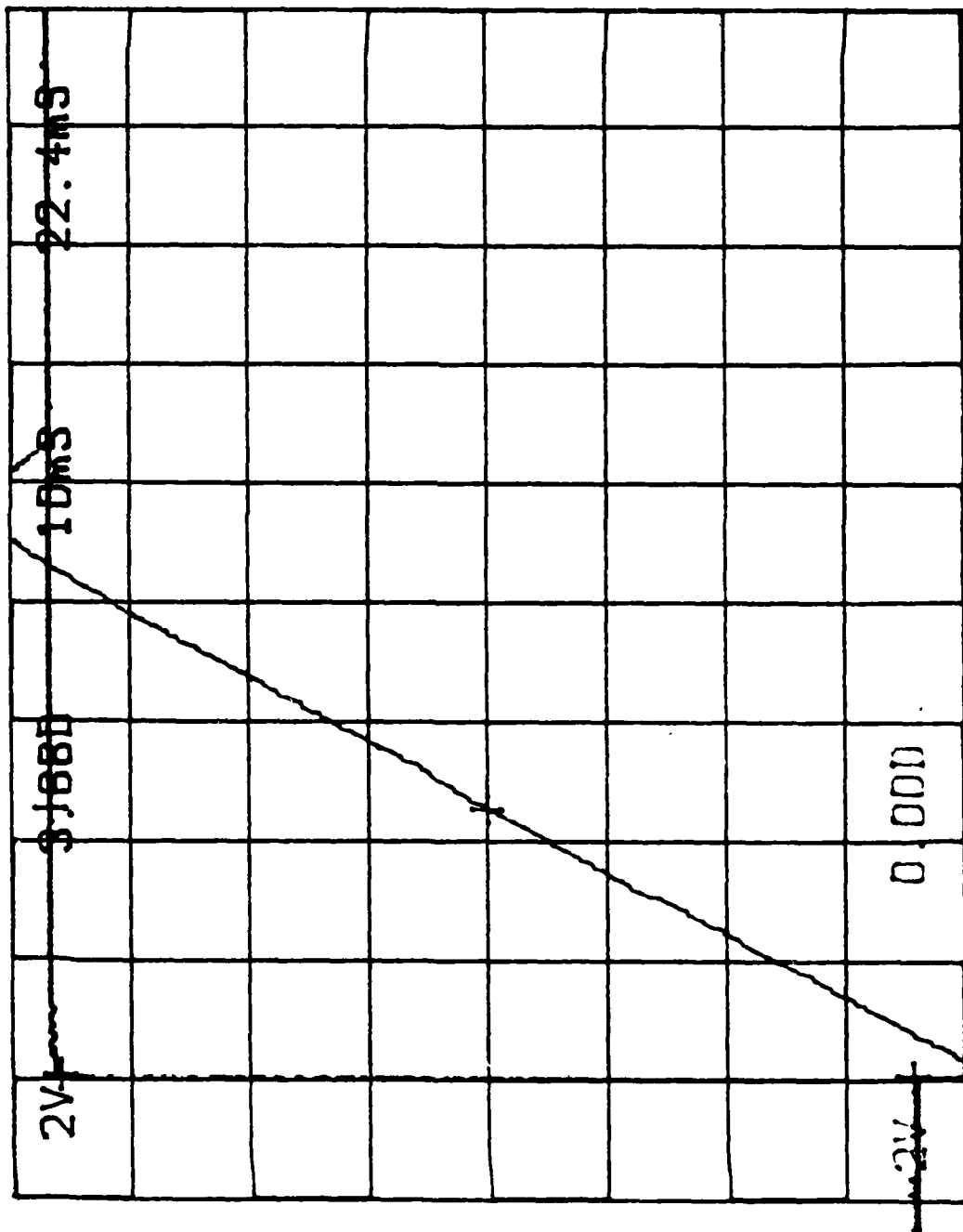

Y AXIS SLEW RATE, MINUS 7.5 VDC TO PLUS 7.5 VDC COMMAND

FIGURE 5-8

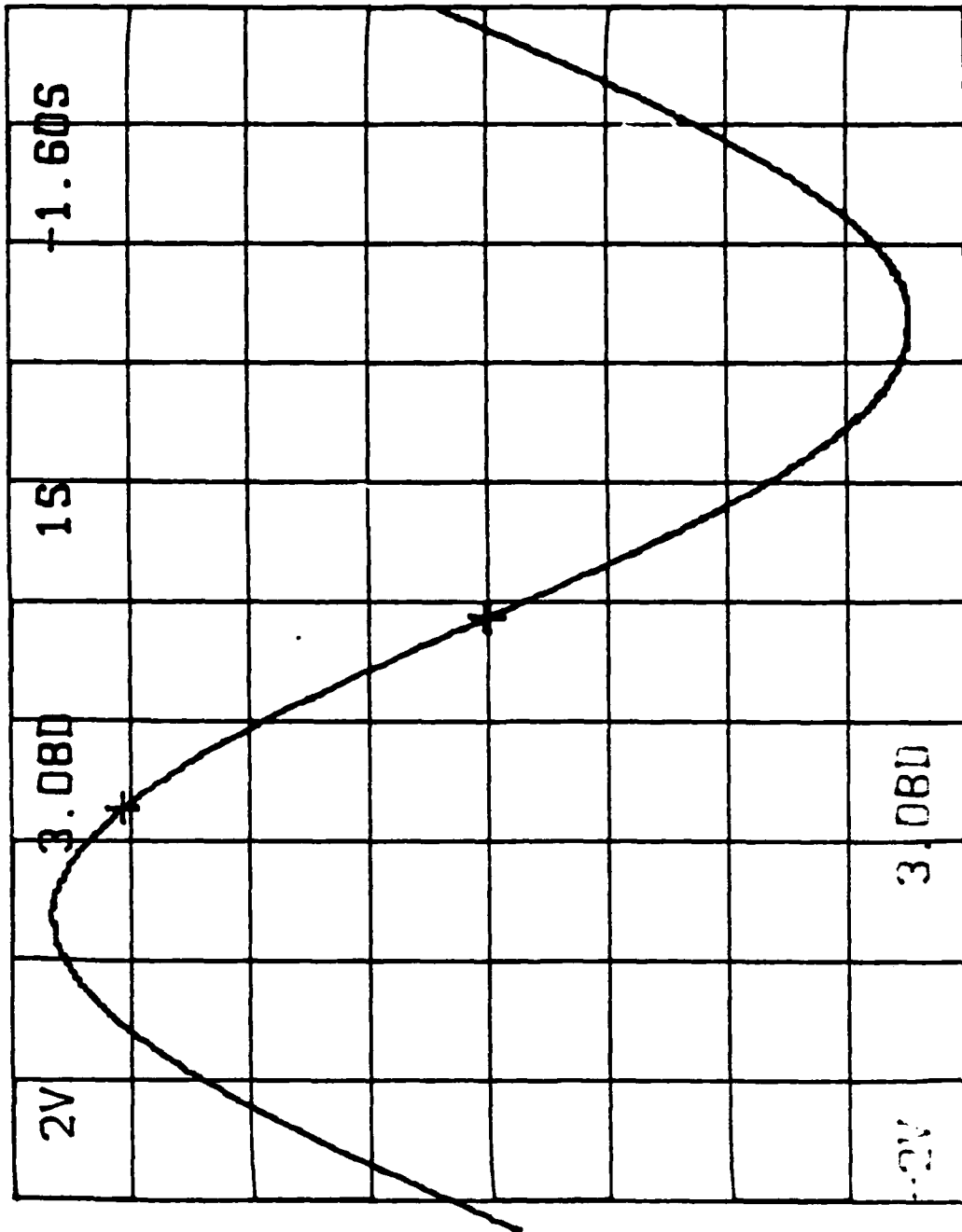

PAGE NO.

50

Y AXIS WAVE FORM - SINE WAVE @ .1 HZ, ± 7.5 VDC

FIGURE 5-9

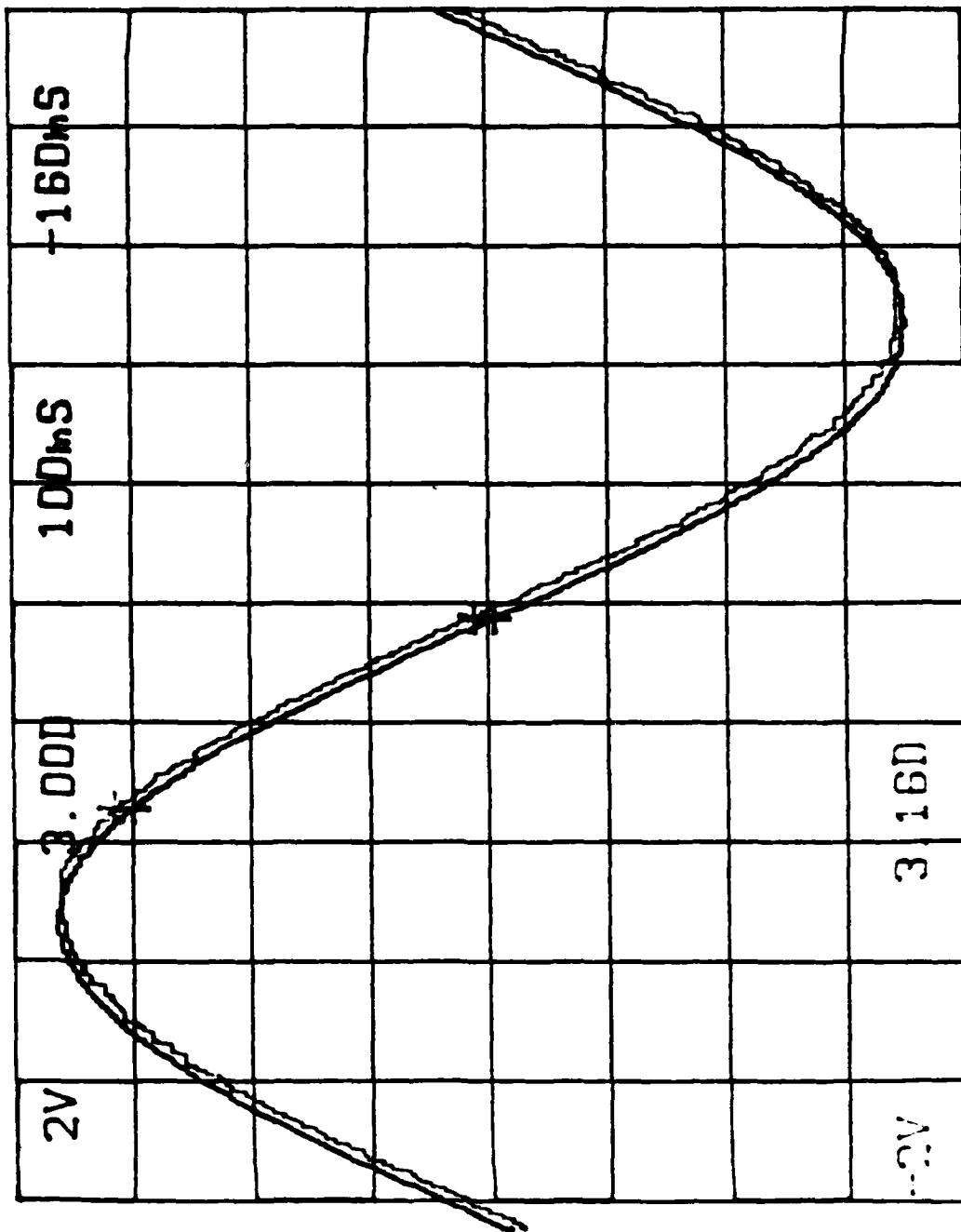

Y AXIS WAVE FORM - SINE WAVE @ 1 HZ, ± 7.5 VDC
 FIGURE 5-10

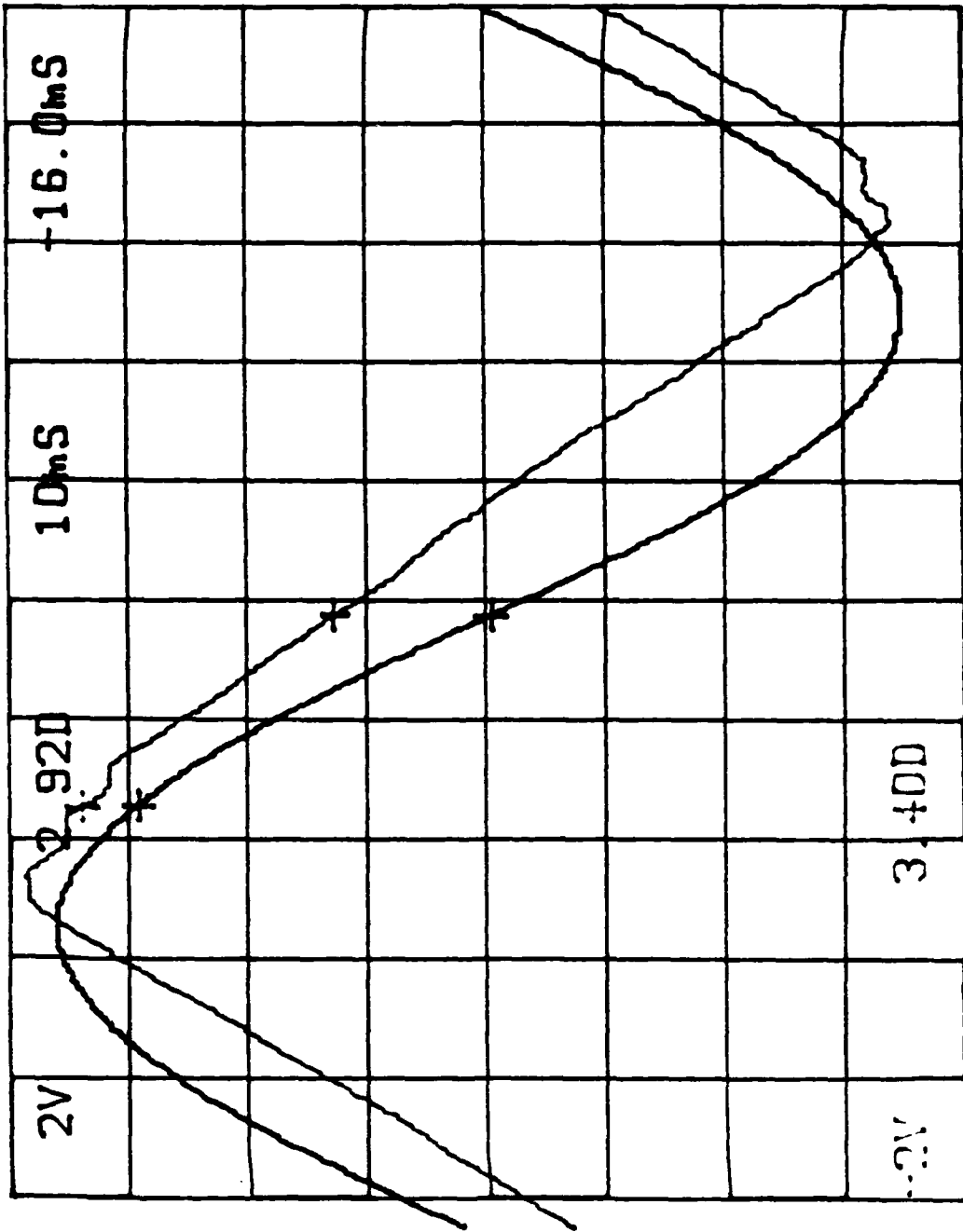

Y AXIS WAVE FORM - SINE WAVE @ 10 HZ, ± 7.5 VDC
 FIGURE 5-11

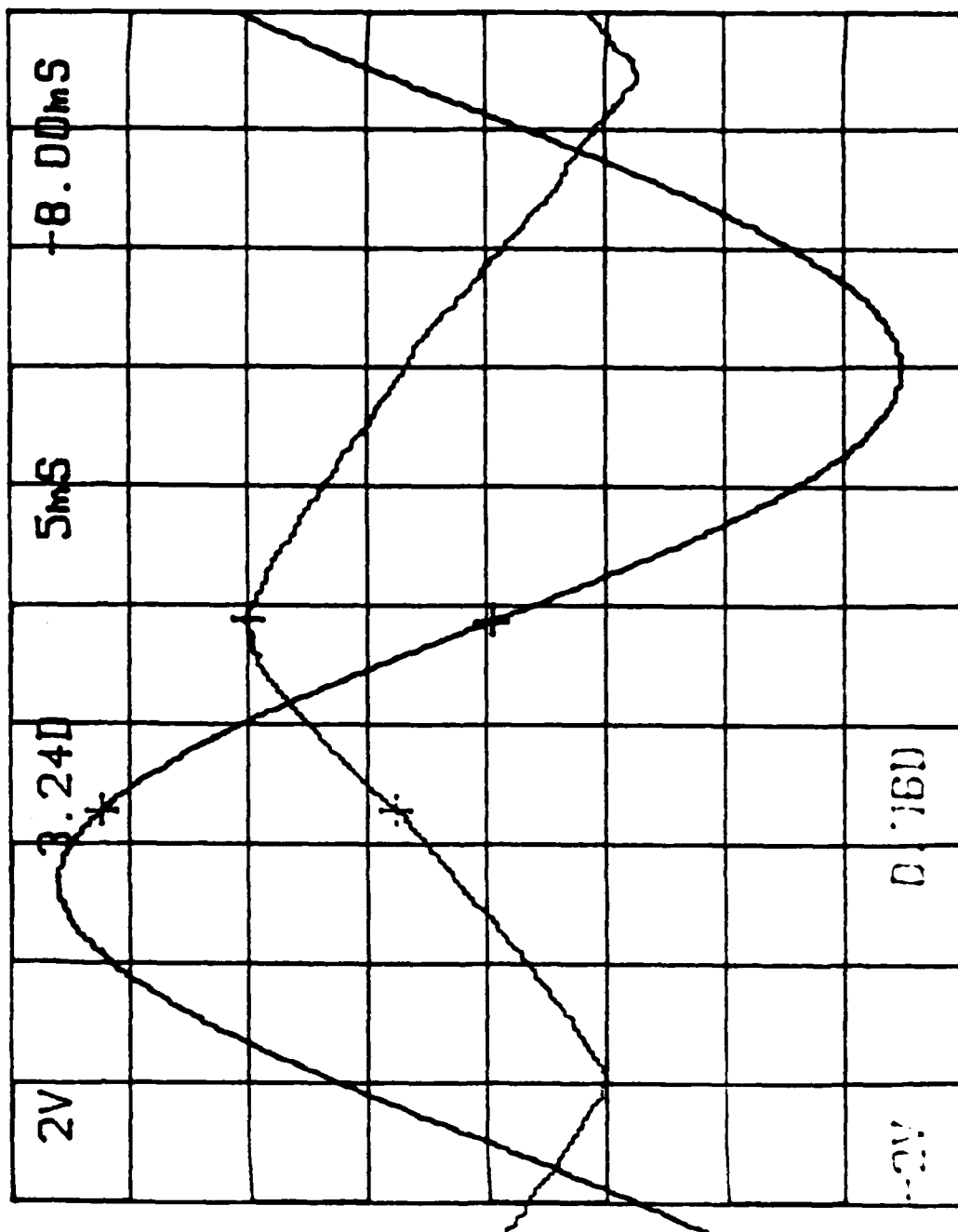

Y AXIS WAVE FORM - SINE WAVE @ 25 HZ, + 7.5 VDC
 FIGURE 5-12

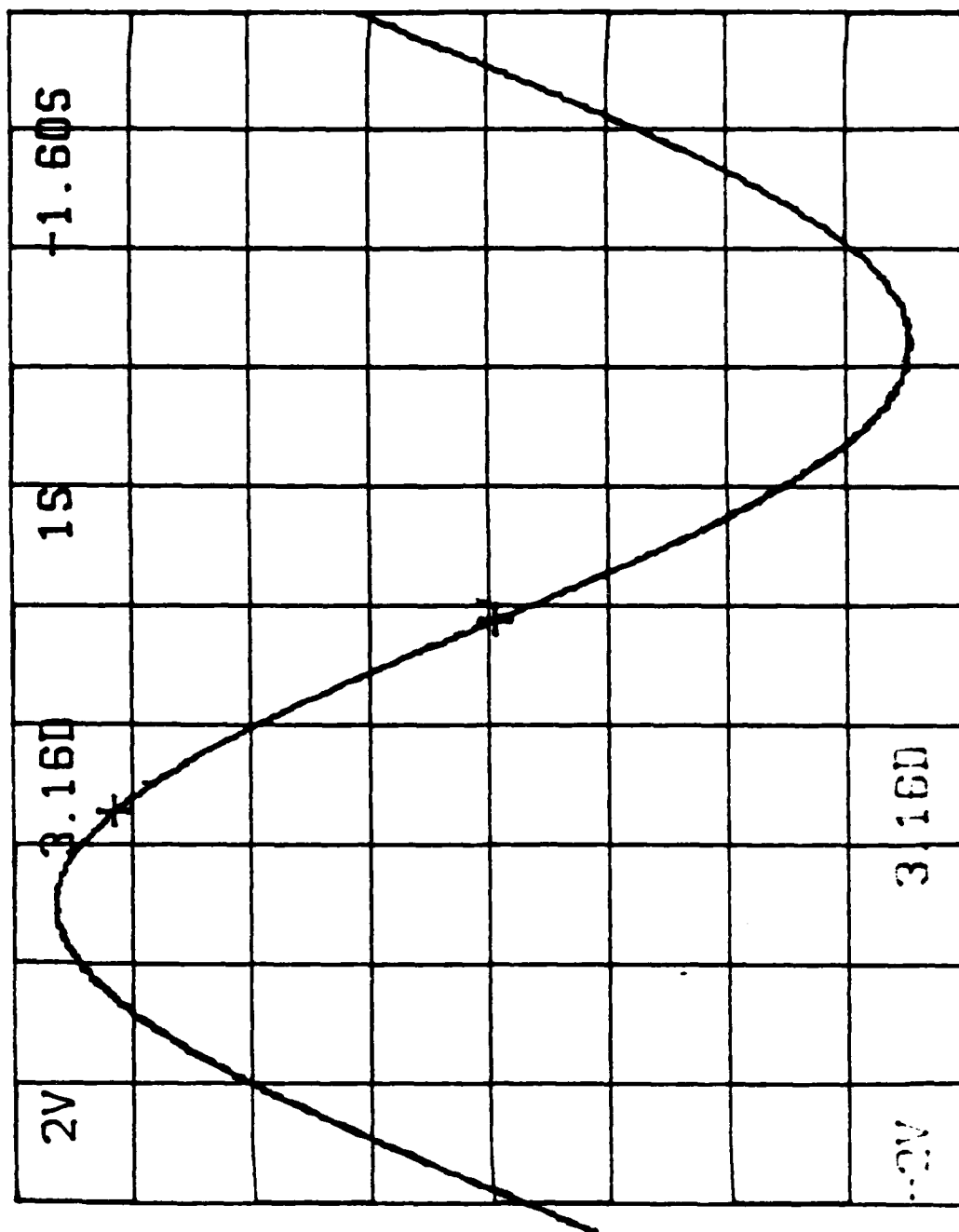

X AXIS WAVE FORM - SINE WAVE @ .1 HZ, ± 7.5 VDC
 FIGURE 5-13

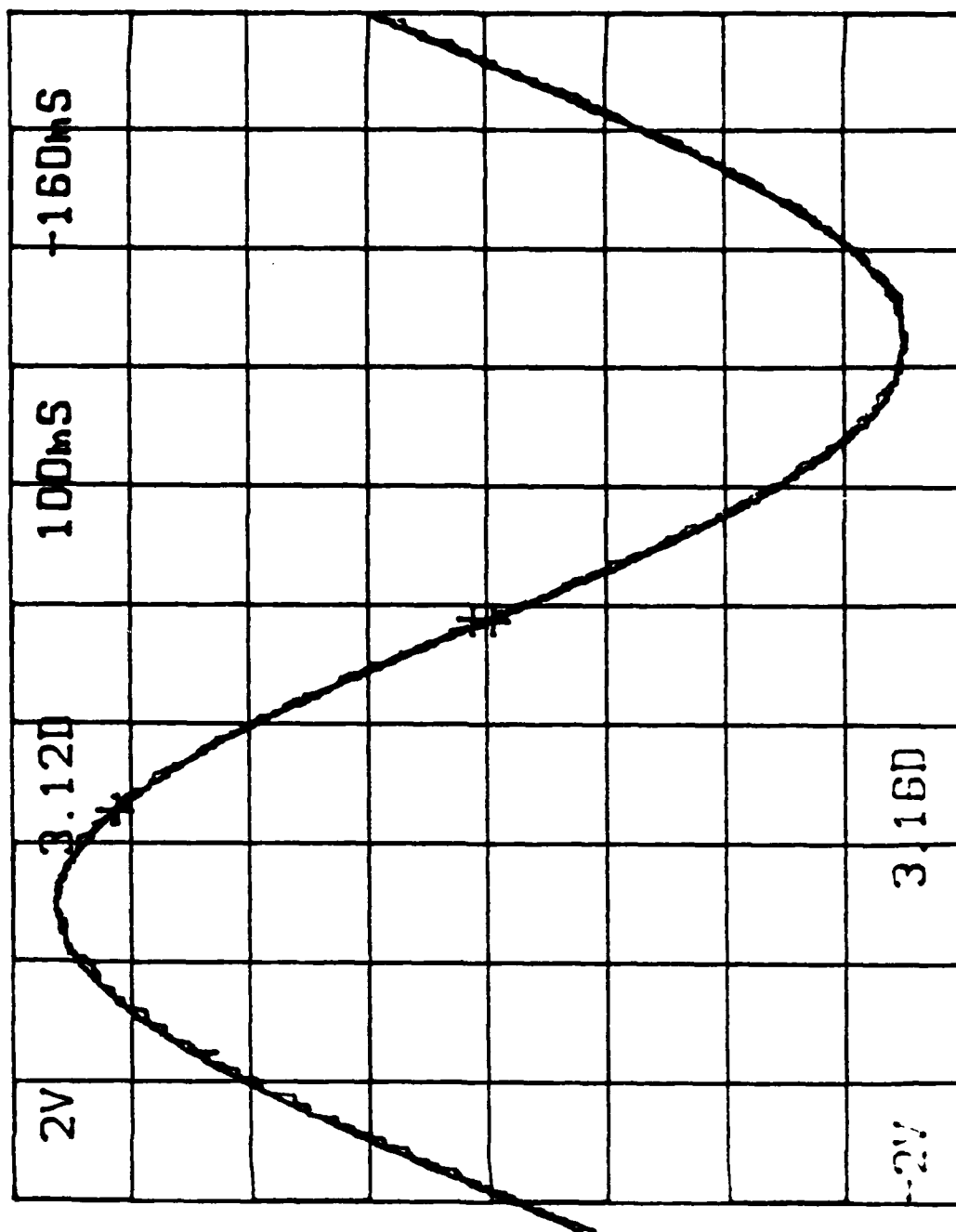

X AXIS WAVE FORM - SINE WAVE @ 1. HZ, ± 7.5 VDC
 FIGURE 5-14

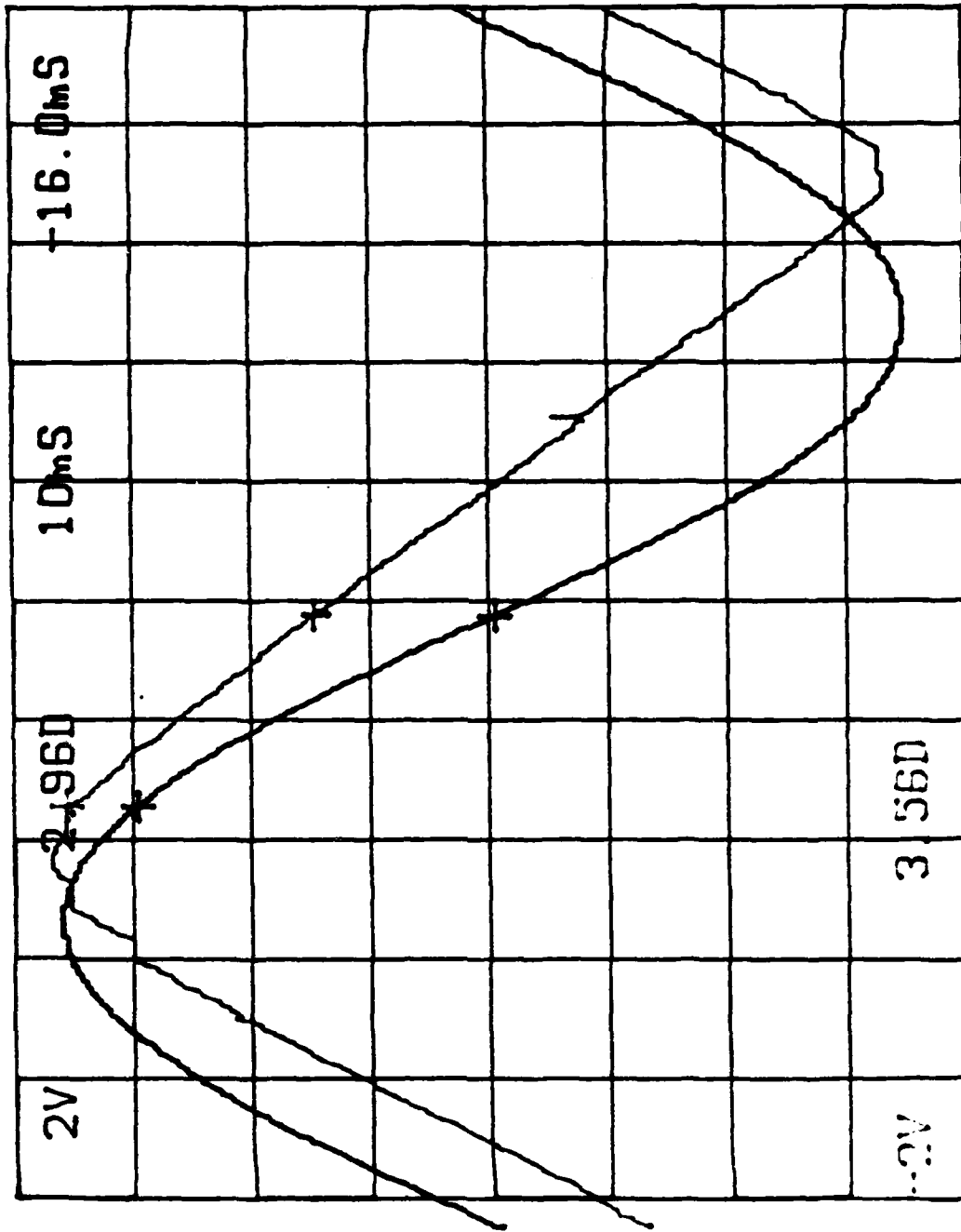

X AXIS WAVE FORM - SINE WAVE @ 10. HZ, ± 7.5 VDC
 FIGURE 5-15

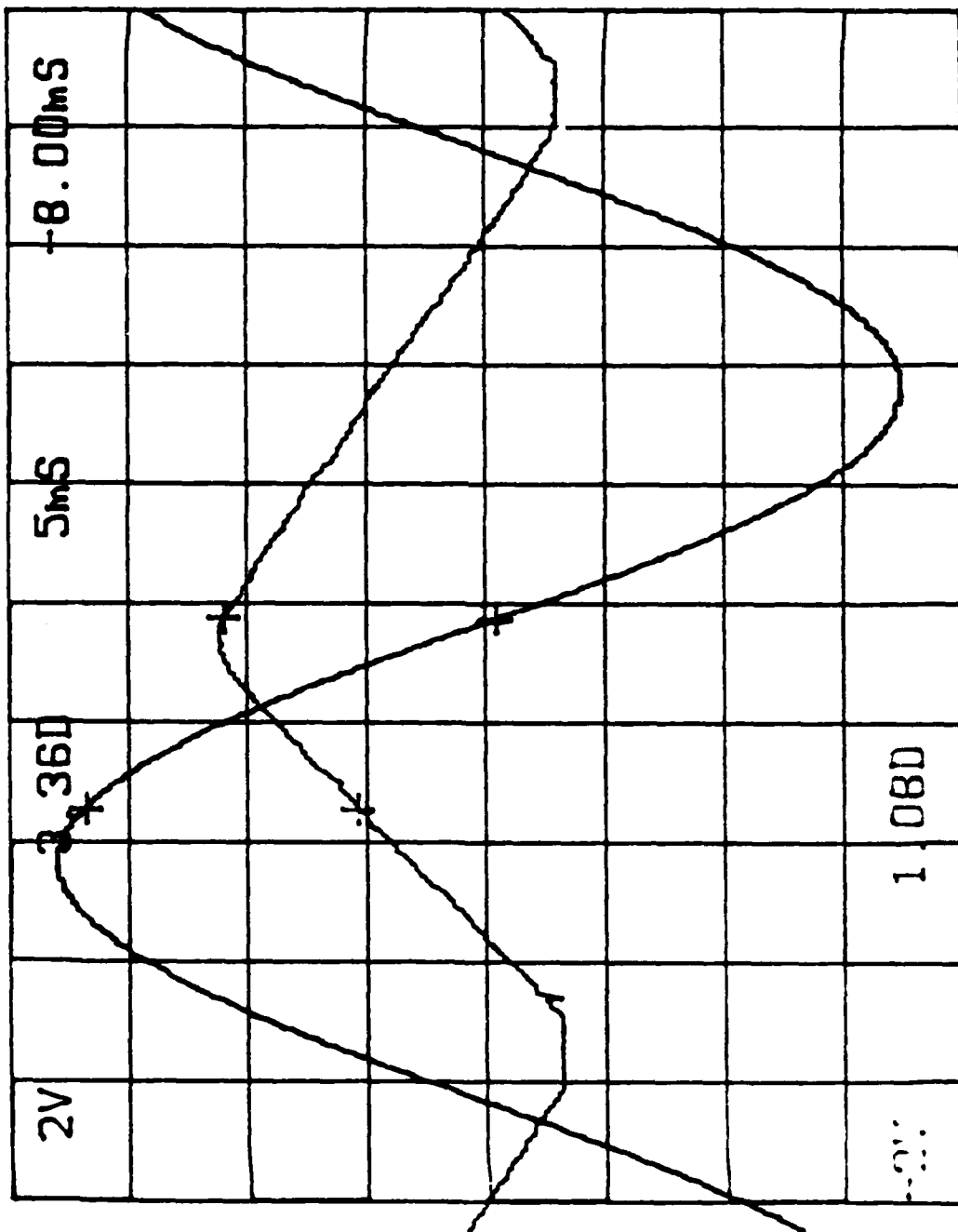

X AXIS WAVE FORM - SINE WAVE @ 25 HZ, ± 7.5 VDC
 FIGURE 5-16

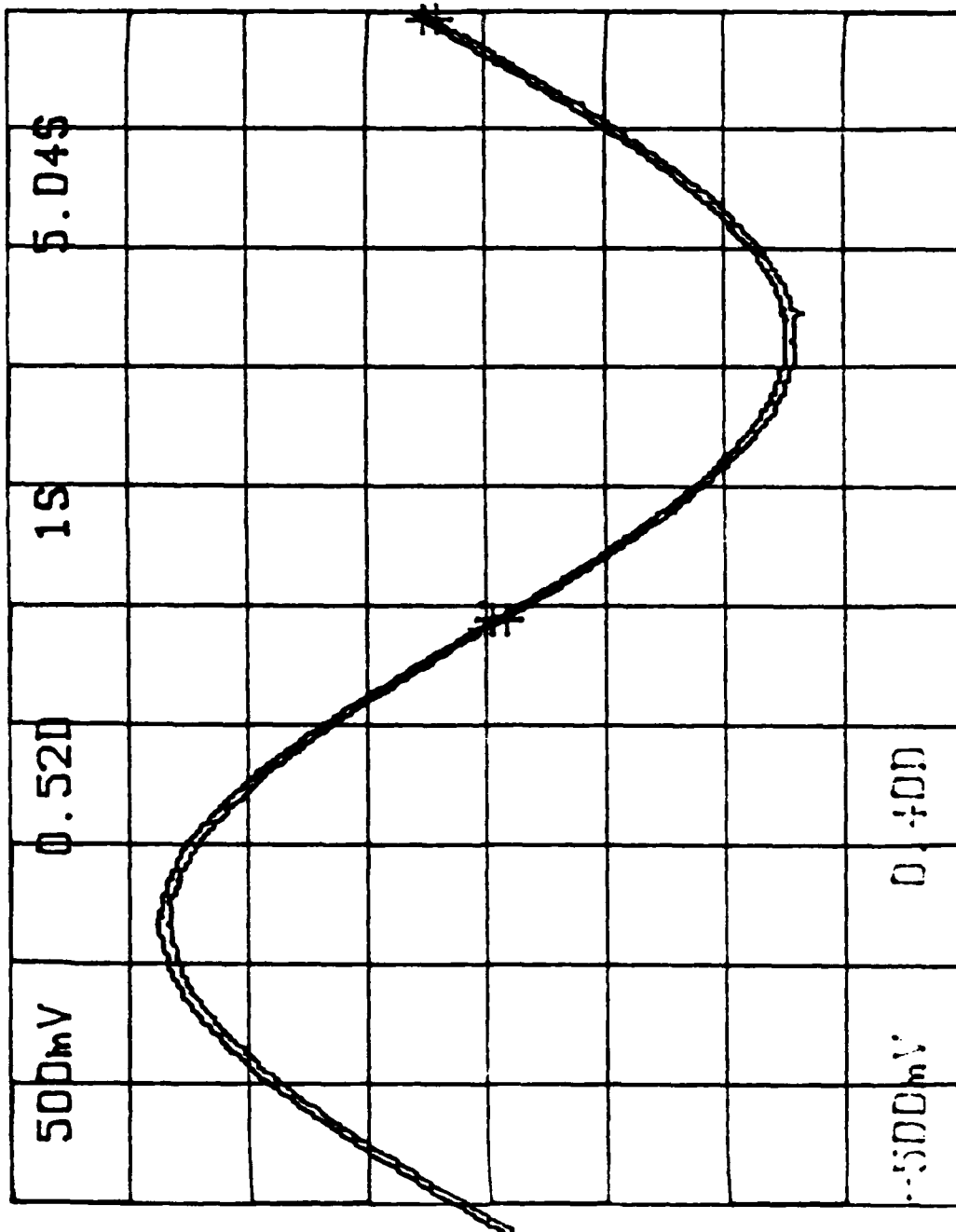

X AXIS WAVE FORM - SINE WAVE @ .1 HZ, ± 1.33 VDC
 FIGURE 5-17

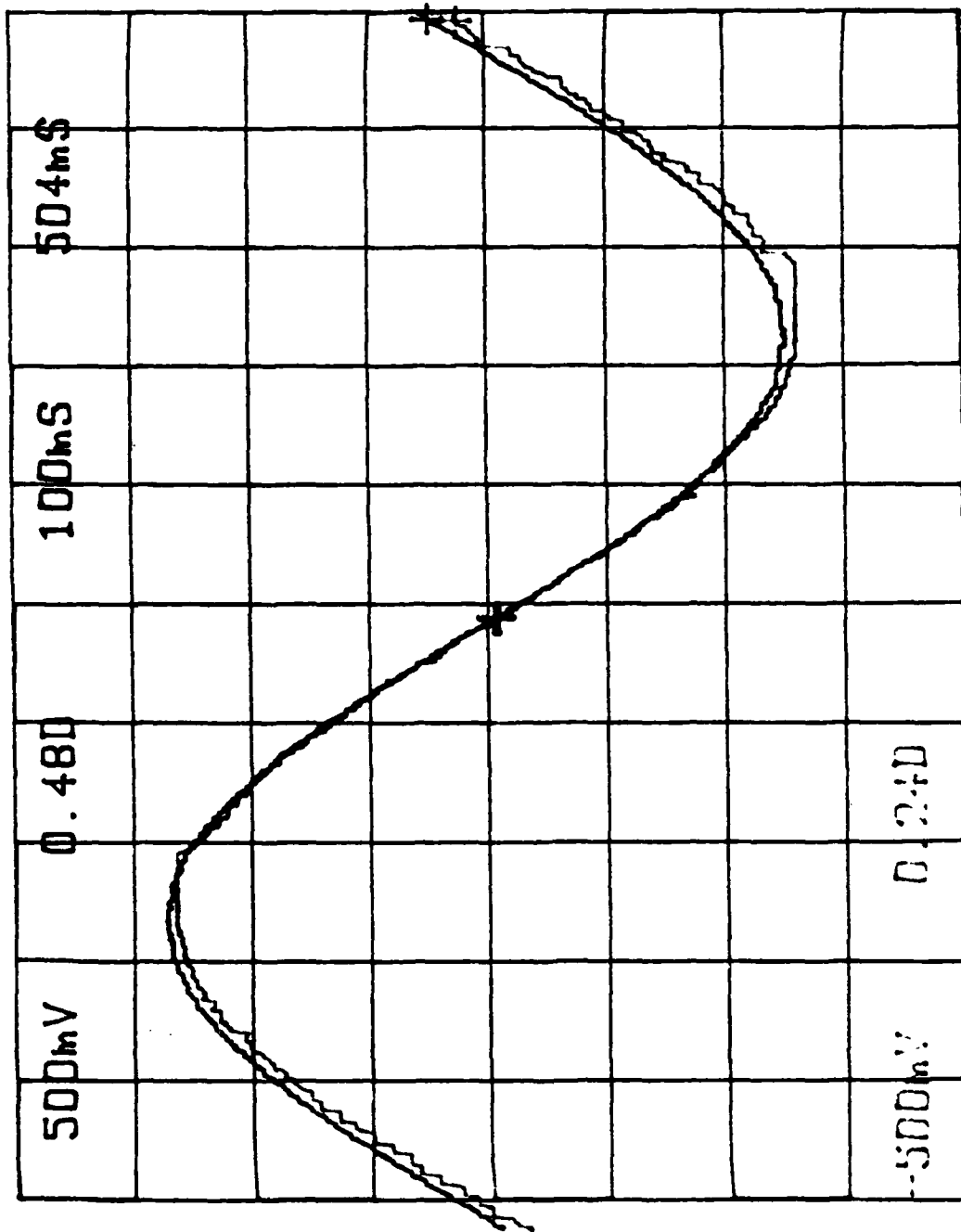

X AXIS WAVE FORM - SINE WAVE @ 1. HZ, ± 1.33 VDC
 FIGURE 5-18

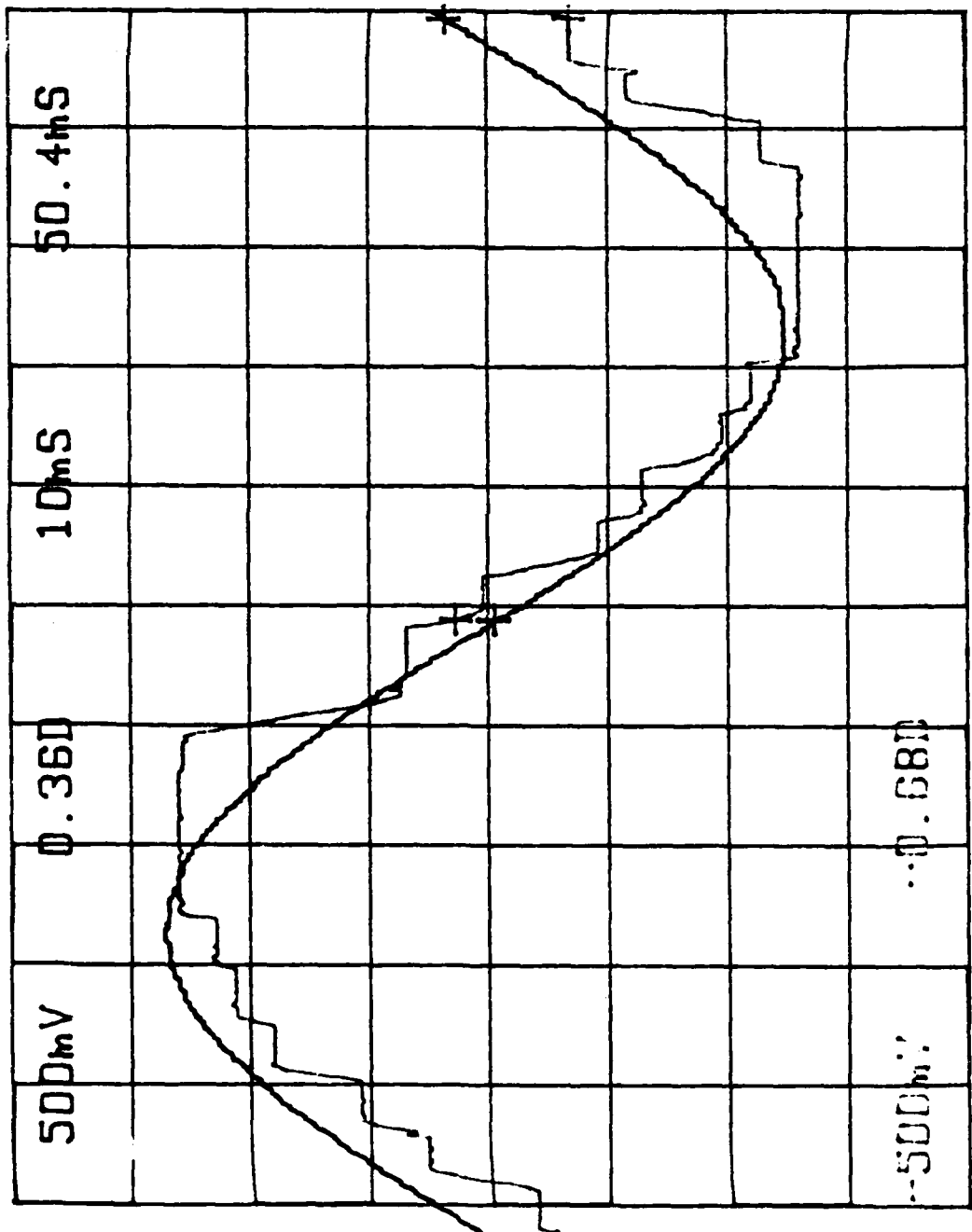

X AXIS WAVE FORM - SINE WAVE @ 10 HZ, ± 1.33 VDC

FIGURE 5-19

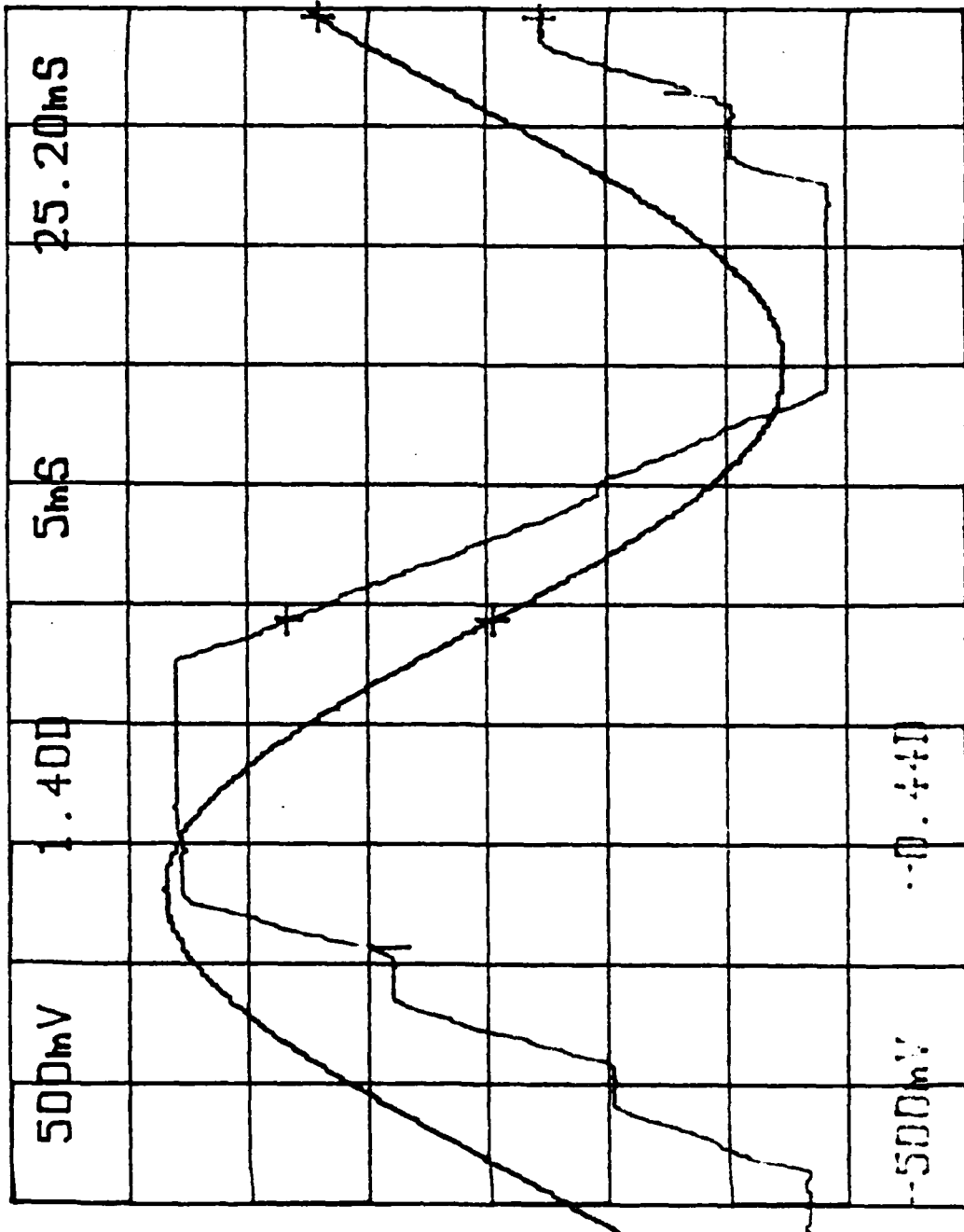

X AXIS WAVE FORM - SINE WAVE @ 25 HZ, ± 1.33 VDC

FIGURE 5-20

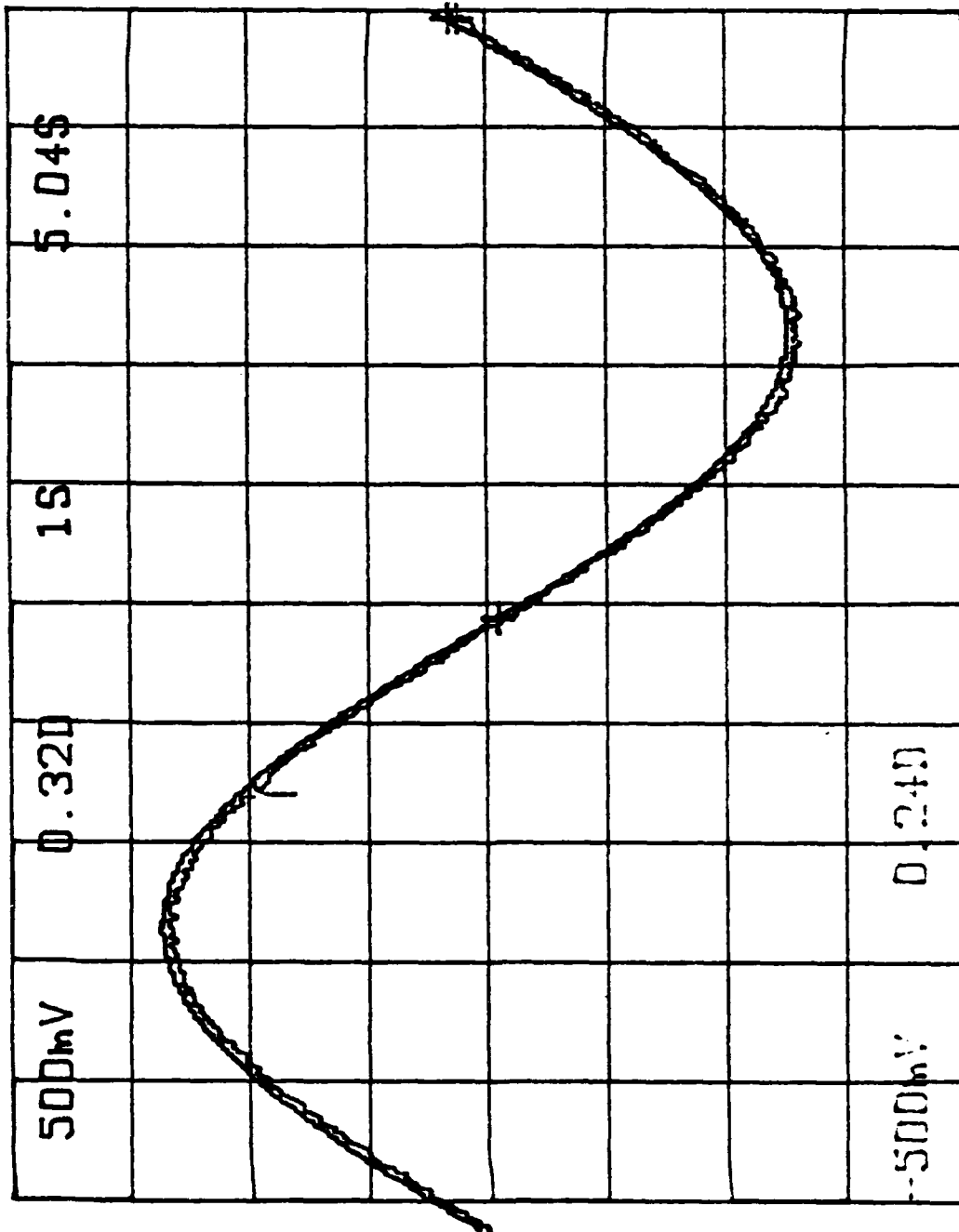

Y AXIS WAVE FORM - SINE WAVE @ .1 HZ, ± 1.33 VDC
 FIGURE 5-21

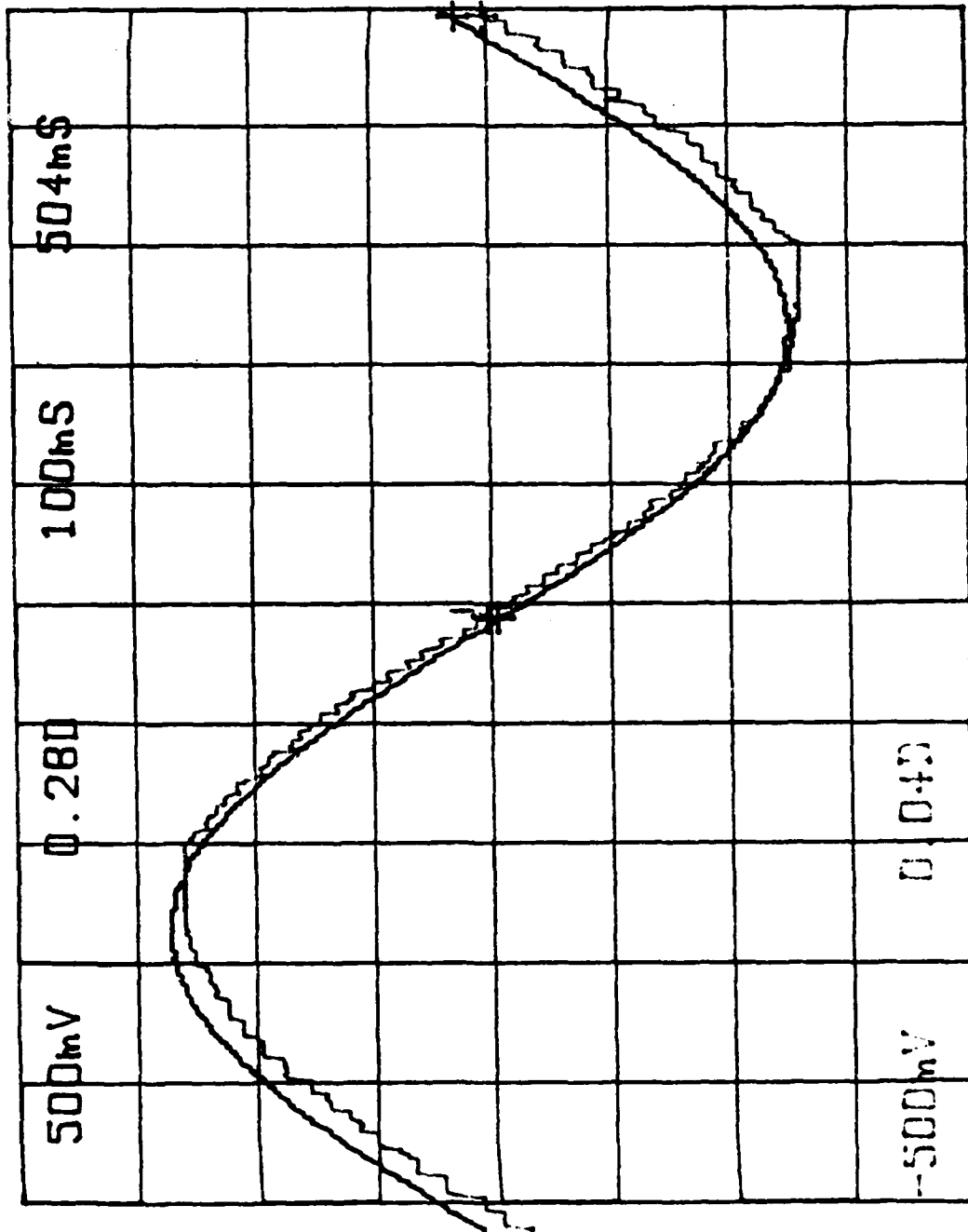

Y AXIS WAVE FORM - SINE WAVE @ 1. HZ, ± 1.33 VDC
 FIGURE 5-22

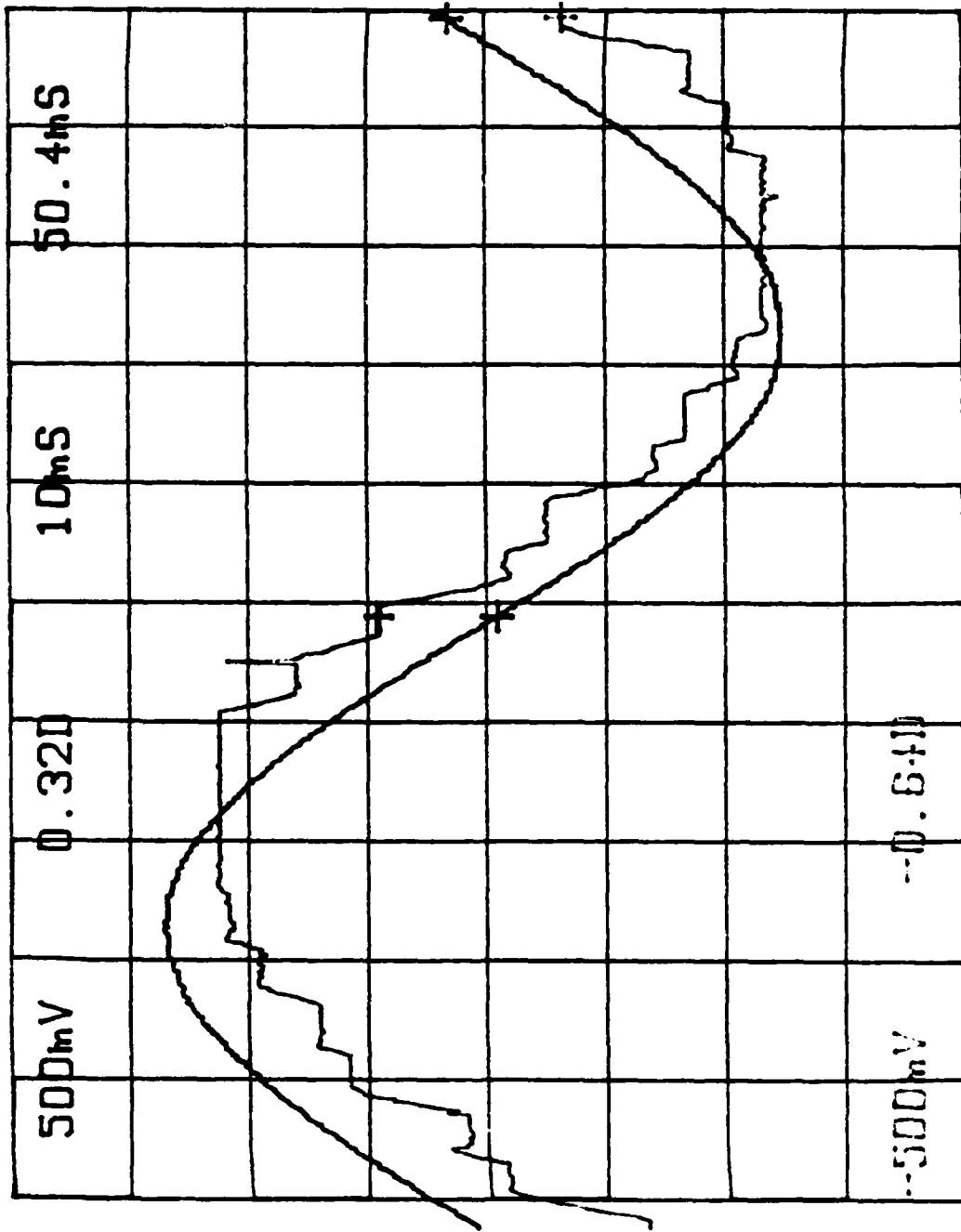

Y AXIS WAVE FORM - SINE WAVE @ 10 HZ, ± 1.33 VDC
 FIGURE 5-23

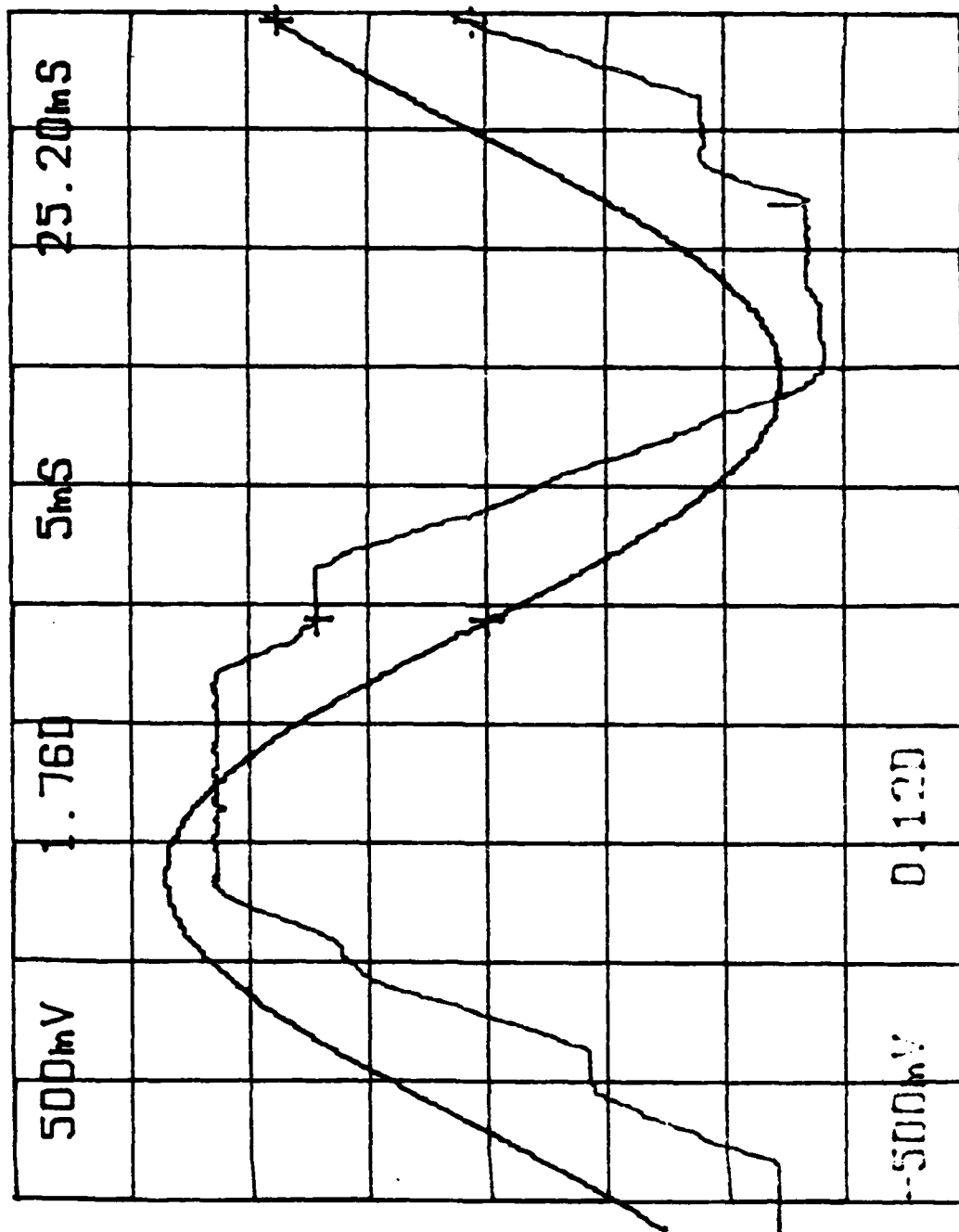

Y AXIS WAVE FORM - SINE WAVE @ 25 HZ, ± 1.33 VDC
FIGURE 5-24

Worthy of note in these plots are the PWM/solenoid steps that appear at the 1 Hz command and become predominant at 10 Hz and above. The amplitude response (gain) is constant out to 25 Hz. The phase lag is quite small at 25 Hz.

5.5 Frequency Response

The amplitude and phase response to a swept sinewave command are shown in Figures 5-25 and 5-26. These plots were obtained using a Bafco frequency analyzer.

The axis demonstrates a small amount of peaking at approximately 25 Hz with a -3 db corner at 45 Hz.

The Y axis response also peaks at 25 Hz (+3 db) and has a minus 3 db corner at approximately 50 Hz.

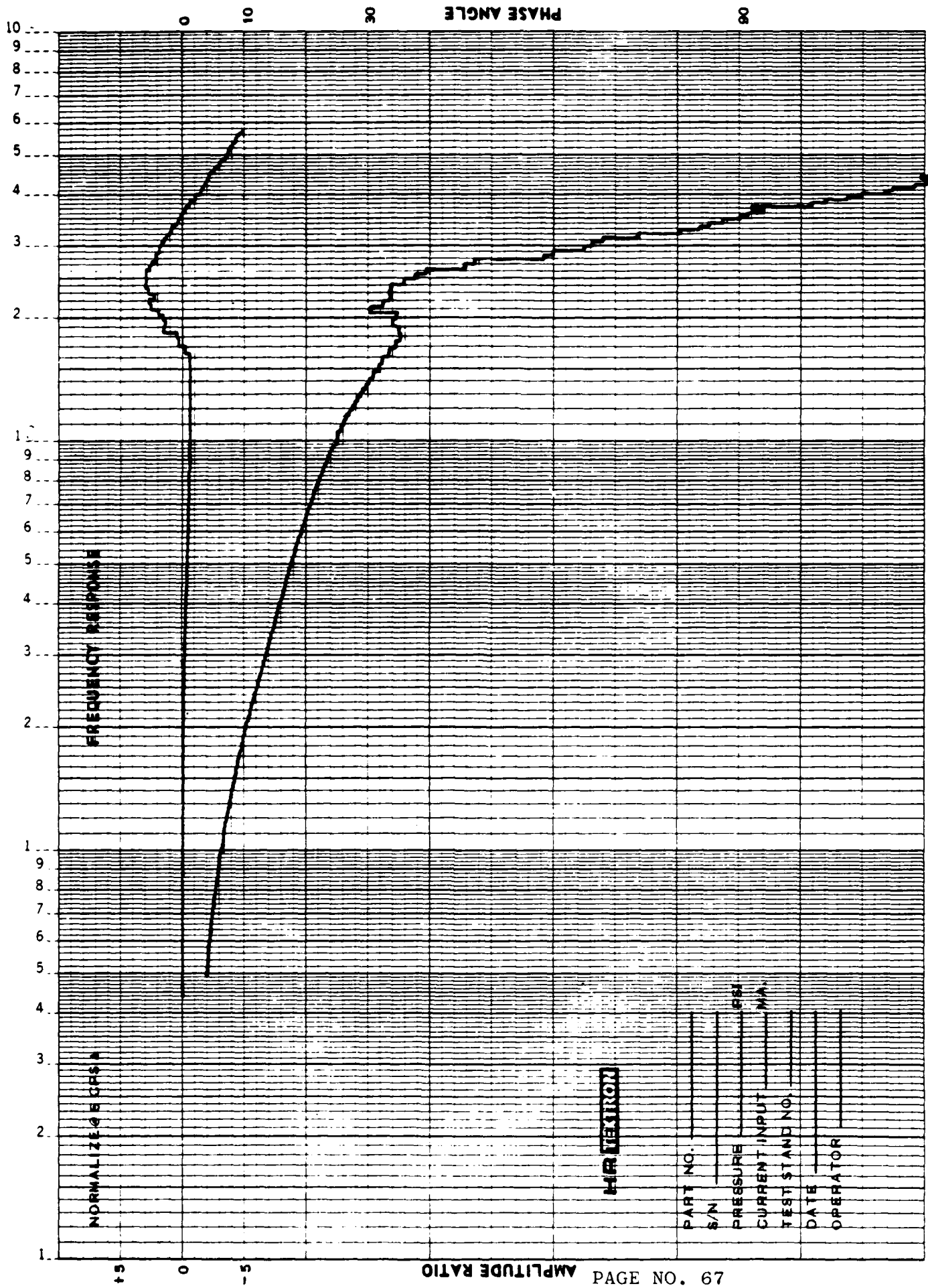

PART NO. _____
 S/N _____
 PRESSURE _____ PSI
 CURRENT INPUT _____ MA
 TEST STAND NO. _____
 DATE _____
 OPERATOR _____

Y AXIS, ± 1.33 VDC ($\pm 2.5^\circ$)
 FIGURE 5-25

NORMALIZED GFS A

FREQUENCY RESPONSE

WATERLOO

PART NO. _____
 S/N _____
 PRESSURE _____
 CURRENT INPUT _____
 TEST STAND NO. _____
 DATE _____
 OPERATOR _____

AMPLITUDE RATIO

PHASE ANGLE

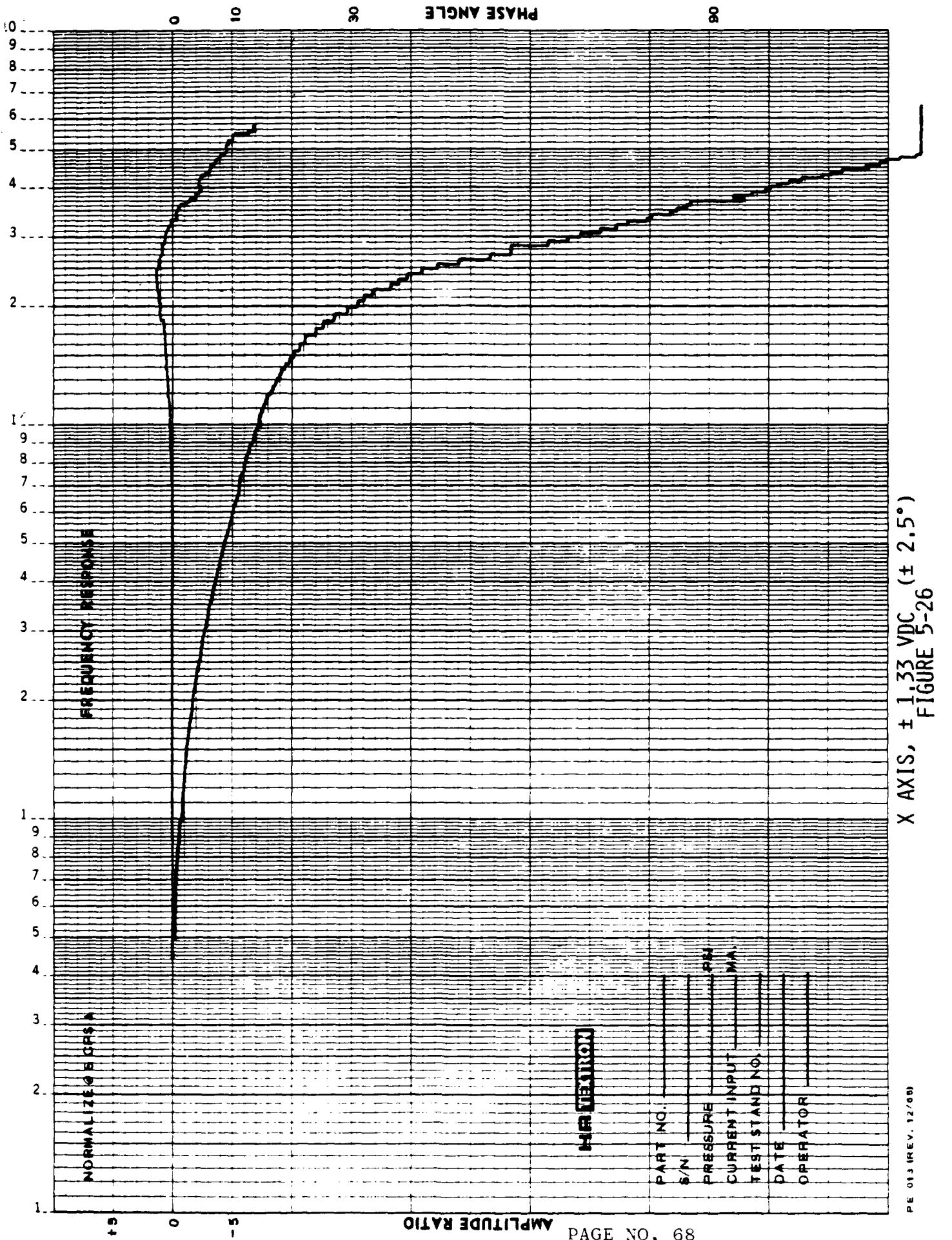

X AXIS, ± 1.33 VDC (± 2.5°)
FIGURE 5-26

END

DATE

FILMED

DTIC

JULY 88