

2

AD

TECHNICAL REPORT ARCCR-TR-88013

DTIC FILE COPY

DESIGN OF A FEELING-THINKING MACHINE

RAYMOND SCANLON

MARK JOHNSON

DTIC
ELECTE
APR 21 1988
S D
COH

MARCH 1988

AD-A194 107



US ARMY ARMAMENT RESEARCH,
DEVELOPMENT AND ENGINEERING CENTER
CLOSE COMBAT ARMAMENTS CENTER
BENET LABORATORIES
WATERVLIET, N.Y. 12189-4060



APPROVED FOR PUBLIC RELEASE; DISTRIBUTION UNLIMITED

88 4 21 - 101

REPORT DOCUMENTATION PAGE		READ INSTRUCTIONS BEFORE COMPLETING FORM
1. REPORT NUMBER ARCCB-TR-88013	2. GOVT ACCESSION NO.	3. RECIPIENT'S CATALOG NUMBER
4. TITLE (and Subtitle) DESIGN OF A FEELING-THINKING MACHINE		5. TYPE OF REPORT & PERIOD COVERED Final
		6. PERFORMING ORG. REPORT NUMBER
7. AUTHOR(s) Raymond Scanlon and Mark Johnson		8. CONTRACT OR GRANT NUMBER(s)
9. PERFORMING ORGANIZATION NAME AND ADDRESS US Army ARDEC Benet Laboratories, SMCAR-CCB-TL Watervliet, NY 12189-4050		10. PROGRAM ELEMENT, PROJECT, TASK AREA & WORK UNIT NUMBERS AMCMS No. 6111.01.91A0.0 PRON No. 1A7BZ701NMSC
11. CONTROLLING OFFICE NAME AND ADDRESS US Army ARDEC Close Combat Armaments Center Picatinny Arsenal, NJ 07806-5000		12. REPORT DATE March 1988
		13. NUMBER OF PAGES 19
14. MONITORING AGENCY NAME & ADDRESS (if different from Controlling Office)		15. SECURITY CLASS. (of this report) UNCLASSIFIED
		15a. DECLASSIFICATION/DOWNGRADING SCHEDULE
16. DISTRIBUTION STATEMENT (of this Report) Approved for public release; distribution unlimited.		
17. DISTRIBUTION STATEMENT (of the abstract entered in Block 20, if different from Report)		
18. SUPPLEMENTARY NOTES Presented at the Fifth Army Conference on Applied Mathematics and Computing, U.S. Military Academy, West Point, New York, 15-18 June 1987. Published in Proceedings of the Conference. <p style="text-align: right;">(CONT'D ON REVERSE)</p>		
19. KEY WORDS (Continue on reverse side if necessary and identify by block number) Non-Living Intelligence Neural Networks Machine Intelligence Thinking Machines		
20. ABSTRACT (Continue on reverse side if necessary and identify by block number) A feeling-thinking machine has been designed using the mammalian brain as a model and current psychobiology concepts as a guide. The machine has been successfully run as a computer simulation. It mimics a primitive organism with eight functional brain centers. They are the reticular ascending substance (RAS), the amygdala, the cingulate gyrus, the medial forebrain bundle, the hippocampus, thalamus, hypothalamus, and the neocortex.		

18. SUPPLEMENTARY NOTES (CONT'D)

Presented at Comcon Spring '88 Conference - "Implementations of Neural Networks," San Francisco, CA, 29 February - 4 March 1988.
Published in Proceedings of the Conference.

Submitted for publication in Scientific American.

UNCLASSIFIED

TABLE OF CONTENTS

	<u>Page</u>
INTRODUCTION	1
THE MODEL	1
THE IMPLEMENTATION	4
TRIAL RUN	9
IMPLEMENTING PACRAT AS A NEURAL NET	10
CONCLUSIONS	11
ONGOING EFFORTS	12
REFERENCES	13

LIST OF ILLUSTRATIONS

1. Anatomy of Pacrat.	14
2. Pacrat.	15
3. Snapshots of Dynamic Graphics Display.	16
4. Cell Activity and Synaptic Facilitation.	17
5. Snapshot of Mouse Display.	18

Accession For	
NTIS GRA&I	<input checked="" type="checkbox"/>
DTIC TAB	<input type="checkbox"/>
Unannounced	<input type="checkbox"/>
Justification	
By _____	
Distribution/	
Availability Codes	
Dist	Avail and/or Special
A-1	

... ..



INTRODUCTION

Machine intelligence for autonomous systems must be capable of learning and especially thinking, if we are to go beyond the 'islands of autonomy' presently envisioned for teleoperated and remotely piloted vehicles. One approach is to use the mammalian brain as a model and investigate the possibility of duplicating its functions in electronic circuitry. This extension of neural network design is called non-living intelligence (NLI).

The brain consists of approximately 10^{12} neurons intricately interconnected. Only a small part of this circuitry has been unravelled. The NLI effort at Benet Laboratories does not describe how the brain works, but involves electronic and computational experiments that provide insight into how the brain might work. We pursue NLI through the design and construction of feeling-thinking machines. Feeling is essential because without motivation, there is nothing. The machine must want to do things. In doing things, it will learn; and having learned, it will think. This report does not describe machines that "exhibit intelligent behavior"; but rather machines that feel, want, and think. The distant goal is to create a machine that thinks and acts like a man. This report discusses the first of a series of feeling-thinking machine designs.

THE MODEL

Our approach to designing this machine is to simulate a primitive organism which must survive within a contrived universe. We have given it the name "Pacrat". Pacrat's brain has eight brain centers. The electrical activity of these neural centers is not modeled, only the functional relationships. From these interactions arises a sophisticated structure which rests upon the anatomy

References are listed at the end of this report.

of Pacrat's brain. The neural centers modeled are: the reticular ascending substance (RAS), the thalamus, the hypothalamus, the amygdala, the cingulate gyrus, the medial forebrain bundle, the hippocampus, and the isocortex (ref 1).

Individual neural response is not simulated, only the activity of assemblages of neurons called codons. A codon is the result or record of an experience. It exists as the altered synapses between the neurons which constitute the assemblage (refs 2,3).

Pacrat, in diagrammatic form, is shown in Figure 1. It shows that he has been provided with the ability to get about in his universe through four motor neurons. These are driven by the motor area of the isocortex as a final result of sensory input, channeled to the isocortex under the control of the thalamus, and filtered through the isocortex under the influence of the prevailing emotion.

Hunger is the level of neural activity in an area of the hypothalamus which we will call the hunger center (ref 4). The model assumes there are sensory neurons lining the stomach wall that respond to expansions and contractions of the stomach. These determine the level of activity of the hunger center. As the stomach empties, the hunger center becomes more active; as the stomach fills, it becomes less active.

Anger is also a level of neural activity in an area of the hypothalamus, but in this case the cause is the activation of certain codons in the isocortex as mediated through the amygdala. When this area is active, Pacrat experiences some level of anger or frustration. The activity in the amygdala is quickly inhibited by eating (refs 5,6).

Fear is the level of activity of the cingulate gyrus. This activity is, subjectively, unease escalating to terror. In Pacrat, it is assumed that sensory neurons excite the cingulate gyrus whenever his back is uncovered. This is agoraphobia, the fear of open places.

Curiosity is the level of activity of the hippocampus. It is set off by the activation of a codon in the isocortex which has not previously been excited. The continual excitation of "old" codons will allow this activity to fade away. Pacrat's hippocampus has efferents on his motor area with the result that "newness" leads to exploratory rather than hunger or fear-driven activity.

All sensory input (other than olfactory) is gated through the thalamus to the isocortex. Thus, the thalamus can relay or block this input. It can also inhibit the motor output that would normally result from activity in the isocortex. The thalamus does this in a rhythmic manner when the reticular ascending substance (RAS) is stimulated. The RAS is excited whenever the hypothalamus or the cingulate gyrus is active.

The thalamus extends this period of choking off sensory input when it receives impulses from a codon through synapses which have been facilitated in the past by the reward-punishment mechanism. This blocking of sensory input and an associated inhibition of motor output is the function of the thalamic reticular complex. On the other hand, if a codon is activated which has a facilitated synapse on the "goal" area of the thalamus (cf., akinetic mutism, (ref 7)), sensory input is gated to the isocortex and the motor output is enabled.

The normal activity of the isocortex is association. During each "moment" there is an active codon which has efferents on the motor output system. If this system is not inhibited, motor output will follow. This codon fades out as

its store of strategic molecules becomes temporarily depleted. As it fades out another codon starts up and the next "moment" begins. The new codon is determined by the sensory input (if not blocked), the previously excited codon, and the current dominant emotion.

A reward-punishment mechanism is started up by the medial forebrain bundle whenever activity in the hypothalamus or cingulate gyrus is reduced. The role of this mechanism is to facilitate all recently fired synapses (ref 6).

THE IMPLEMENTATION

Pacrat exists in a contrived universe: a very simple universe which is seen as partitioned by a rectangular grid (Figure 2). At each location in the grid one of Pacrat's sensory neurons, unique to that location, becomes active. This gives him a location sense. At genesis he does not know where one location is relative to another, but he does know that he is where he is. He has also been given the ability to sense his own trail, and has a general aversion to going where he has recently been. Again, the individual activity of the sensory neurons is not simulated, only the relationship with other active neurons. His burrow (or starting point) is always at row 11, column 1. This is indicated by blue shading in that cell. Pacrat's current location is given by the green cell (refs 8,9).

One codon is active at any time and this represents a 'moment' in Pacrat's life. This codon is excited by current sensory input to the isocortex plus the previously excited codon and the prevailing emotion. The inputs are the location sense, which is gated through the thalamus (Figure 1), smell, the axonal

bundles from the hypothalamus, and cingulate gyrus. A codon in the simulation is simply a vector of scalars representing the current sensory input (if any), normalized synaptic weights to the four motor neurons, associative connections to other codons, dominant emotion, and synaptic weights to the amygdala, thalamus, and hippocampus (ref 10).

Pacrat's motivation is hunger and fear. When awake, Pacrat is forced to move by one or the other, or else he just goes to sleep as the RAS quiets down (ref 4). Initially, this drive is hunger. In the simulation, the distension of the stomach is represented by a scalar. This number continually decreases unless Pacrat is at a food spot and is eating. When this number is low enough, the hypothalamus responds (again a scalar) and the RAS is excited. Pacrat wakes up. He is forced to explore his universe for food to satisfy hunger. Food is placed randomly in one of three locations. The three potential food spots are shown on the right side of the grid, with food located in the cell shaded blue. When he reaches a food spot, he eats, his stomach fills up, and the activity in the hypothalamus is significantly reduced. This is simulated by simply increasing the number corresponding to distension of the stomach which is sensed by the neurons lining the stomach wall. These neurons have efferents to the hypothalamus.

Pacrat can move north, south, east, and west within the boundaries of his universe. Motor neurons drive Pacrat in one of these directions one cell at a time. Each active codon in the isocortex has efferents on each of these motor neurons and the relative effectiveness of these efferents determines the direction of travel. At the outset, i.e., trial 1, there is no preferred direction of movement. The synaptic weights from any given codon to the motor neurons are

identical. Pacrat moves about his universe randomly until food is found. When it is, a reward mechanism is activated through the medial forebrain bundle which facilitates all recently fired synapses. This is learning and will generate a preferred direction of movement when similar codons are active in the future. The vectors representing codons are changed so that elements corresponding to synaptic connections between simultaneously active neurons are increased. Facilitation is proportionally lower for codons active earlier in time.

After hunger is satiated and the level of activity of the hypothalamus reduced, fear is no longer masked by hunger. Fear keeps the activity of the RAS high. An active cingulate gyrus drives Pacrat back to his burrow. Again, if this is the first trial, there is no preferred direction, but the codons which are activated are those associated with fear rather than hunger. The neurons in the cingulate gyrus, not the hypothalamus, excite neurons in the isocortex. When his burrow is reached, Pacrat's back is covered. The activity of the cingulate gyrus is abruptly decreased. The reward mechanism is again activated through the medial forebrain bundle and recently fired synapses are facilitated. This will generate biased movement in the future if these codons are active. Henceforth, at any cell in the grid, he will tend to go in a direction depending on which neurons are active in the brain centers. An active hypothalamus may move him east; an active cingulate gyrus with the same sensory input may drive him north.

During epigenesis, Pacrat learns to survive. Randomness forces Pacrat out of obsessive behavior patterns. Although a reward mechanism may increase synaptic strength between a codon and a given motor neuron, there is always a chance Pacrat will move in a different direction. A built-in random element raises the

level of activity of motor neurons with a lower synaptic weight to the currently active codon. An active hippocampus increases the effect of this random element. If this were not present, Pacrat would not survive. Once food were found, he would follow the same path again and again. However, as the synaptic strength between a codon and motor neuron is increased, it becomes more and more difficult for Pacrat to alter his behavior. He will continue searching for food in locations where it does not exist. To resolve this we have given Pacrat an amygdala. An active amygdala mediates anger. Excited neurons in the amygdala generate unique active codons in the isocortex. Figure 1 shows the role of the amygdala in Pacrat. When the reward mechanism is active, all recently fired synapses are facilitated through the medial forebrain bundle. These include synapses from the active codon in the isocortex to the amygdala. Therefore, if this same codon is excited in future trials, the amygdala also becomes highly active. This high level of activity excites a region in the hypothalamus associated with anger or frustration. Unless there is a concurrent good experience, such as eating, which will inhibit the amygdala, Pacrat will become angry. In other words, he gets mad when food is not where it is supposed to be. This anger quickly drives Pacrat out of the vicinity of a food spot by exciting different codons in the isocortex. These codons do not have synaptic weights to the motor area that favor any given direction. He is effectively 'bounced' randomly to neighboring locations in the grid. Without the amygdala, Pacrat would keep looking for food in the same spot almost indefinitely. The level of activity in the hypothalamus is far greater than that of the hippocampus. When he is starving, he doesn't get bored.

The effect of rhythmic action of the thalamus is that a moment (active codon n) that generates motor output is followed by several moments (active codons $n+1, n+2, \dots$) with motor output inhibited. This is the first of three forms that thinking takes. The sensory input is temporarily blocked, motor output inhibited, and associated codons in the isocortex are turned on. This form of thinking is implemented in Pacrat as he effectively evaluates the consequences of his last move.

A second form of thinking comes about when an excited thalamus results in an extended period of blocking of sensory input. Again, the normal state in the isocortex is association so codons continue to fade in and out. If the chain of associating codons reaches a codon with inhibitory efferents on the thalamus, activity of neurons in the reticular complex is reduced. The blocking cycle of sensory input is reduced to a minimum and Pacrat proceeds to move with intent. This form of thinking is recognition. It is initiated when Pacrat moves to an area of particular interest to him on the grid. This is a location where synapses from the isocortex to the thalamus have been facilitated from previous rewards.

A third form of thinking comes about when the extended period of blocked sensory input and inhibited motor output results in slightly different associated codon chains. This can occur because of the inherent randomness of neural actions. If one of these chains results in activating a codon quicker than recent paths have done, the neurons of this codon are in a different state of molecular depletion. It has had less time to recover from the last activation. It comes on with a burble which is transmitted to the reward system, and recently fired synapses are facilitated. This is insight and is the basic mechanism of rational thought. Pacrat has demonstrated this by "thinking" of more efficient paths to food.

TRIAL RUN

Figure 3 shows four static displays of a typical trial run of the simulation. Figures 3a through 3d are snapshots in trial 702. The activity of the brain centers is given by a red bar chart on the left side of the display. The larger the bar, the more active that area of the brain. Even number trials (i.e., 702) display the effect of a particular neural center (i.e., hunger, anger), while odd number trials (i.e., 703) give the name of the center. The number of steps indicates the sequence of each snapshot in the trial.

In Figure 3a Pacrat has just left his burrow, the starting point. The activity of the hypothalamus was high enough to activate the RAS and wake him up. Figures 3a through 3c show Pacrat driven by hunger. Through epigenesis, which is his previous 701 trials, he has learned. Figure 3b shows Pacrat with his motor output inhibited by the thalamus. This is shown by freezing him at his current location and changing his color to a deep red while dynamically displaying his codon association chain in yellow. The reward cell for this trial is in the middle of the three possible food locations (row 11, column 18). From past experience, food has been known to be located in the last reward cell (row 19, column 18). Pacrat's codon chain eventually associates to this location, and facilitated synapses from the isocortex stop the thalamus from blocking sensory input and inhibiting the motor area. Pacrat is green when his motor output is not inhibited. Figure 3c shows the active amygdala when food is not found where it was expected. Pacrat turns purple when the activity at the amygdala exceeds a given threshold.

His frustration forces him out of the vicinity of the empty food cell and eventually he locates the food. Figure 3d shows Pacrat moving with intent back to his burrow, driven by fear. Pacrat is green, indicating that motor output is

not disabled. The activity in the thalamus (thinking) indicates it has been inhibited from blocking sensory input and from inhibiting motor output. This is a result of recognition resulting in strong inhibitory input from the isocortex.

IMPLEMENTING PACRAT AS A NEURAL NET

A simplified version of Pacrat has been implemented using only simulated neurons, formal definitions of neural activity, and synaptic facilitation. Neural activity is modeled using PID (proportional-integral-differential) control. The governing equations for cell activity and synaptic facilitation are given in Figure 4. Synaptic facilitation has both a Hebbian (associative) and a non-Hebbian (reward-punishment) component.

This simulation is called Mouse. Figure 5 gives a static display at one point in the simulation. The shaded circles on the left represent neurons. Mouse, like Pacrat, lives in a bounded universe. This universe is the ten by ten grid on the right. At each cell in the grid, a single sensory neuron becomes active. The color of the circles reflects the activity. The color changes gradually from blue to red to white as the activity increases. Each sensory neuron has excitatory efferents on each of four motor neurons. These motor neurons are labelled N (north), S (south), E (east), and W (west). When the activity of one of these motor neurons exceeds a preset threshold, Mouse moves one cell in that direction (within the boundaries) and a different sensory neuron becomes excited. As in Pacrat, there are three potential reward cells. At the beginning of each trial, food is placed randomly in one of these cells. These cells are the three blue cells in column 9 as shown in Figure 5. The dark blue cell gives the location of the reward cell for that trial. When Mouse reaches a cell where food is located, a reward mechanism is activated and

recently fired synapses are facilitated. The normalized synaptic weights from the sensory neurons to the motor neurons are shown by the arrows in the grid. There is always an element of randomness associated with each move, but the larger the arrow the more likely Mouse will move in that direction. Initially, (i.e., trial 1) Mouse has no preferred direction of movement and the arrows have zero length and direction. Figure 5 gives the normalized weights after 1000 trials. Mouse always starts at row 6, column 1, which is shaded dark blue. He is displayed as a green square. In order to avoid obsessive, compulsive behavior, Mouse has been given a sense of smell. He is designed to avoid his own trail. This is accomplished via four sensory neurons with inhibitory efferents on the motor neurons. These are labeled 1/N, 1/E, 1/S, and 1/W indicating their effect on that direction of travel. The necessity for these is evident if one imagines four arrows in the grid forming a loop.

Figure 5 shows Mouse after a single move. He has just moved north so there is a high level of neural activity in the neuron inhibiting motor neuron S (south). Since this is the 1000th trial, Mouse has a preferred direction of movement. At this location, as shown by the arrow, it is east. The large synaptic weighting from the currently active sensory neuron to motor neuron E (east) is raising the activity of this motor neuron more than the others. It is therefore likely that Mouse will move east.

CONCLUSIONS

A brassboarded feeling-thinking machine is possible. We believe it is not practical at the moment to consider casting everything in silicon, therefore the neural network section of the machine will be emulated in a highly parallel computer ensemble.

ONGOING EFFORTS

The Pacrat simulation is being completely rewritten so that the neurons are explicitly modeled. This is preparatory to moving the simulation to a transputer network running under an Occam harness.

REFERENCES

1. Gregory, R.L., "Do We Need Cognitive Concepts?," in: Handbook of Psychobiology, (M.S. Gassaniga and C. Blakemore, eds.), Academic Press, New York, 1975, pp. 607-628.
2. Palm, G., Neural Assemblies, Springer-Verlag, Berlin, 1982.
3. Palm, G., "Associative Networks and Cell Assemblies," in: Brain Theory, (G. Palm and A. Aertsen, eds.), Springer-Verlag, Berlin, 1986, pp. 211-228.
4. Kissin, B., Conscious and Unconscious Programs in the Brain, Chapter 2, Plenum Publishing Corp., New York, 1986.
5. Flynn, J.P., Vanegas, H., Foote, W., and Edwards, S., "Neural Mechanisms Involved in a Cat's Attack on a Rat," in: The Neural Control of Behavior, (R.W. Whalen, R.F. Thompson, M. Verzeano, and N.M. Weinberger, eds.), Academic Press, New York, 1970, pp. 135-173.
6. LeDoux, J.E., "The Neurobiology of Emotion," in: Mind and Brain, (J.E. LeDoux and W. Hirst, eds.), Cambridge University Press, Cambridge, 1986, pp. 301-358.
7. Girvin, J.P., "Clinical Correlates of Hypothalamic and Limbic System Function," in: Neural Integration of Physiological Mechanisms and Behavior, (G.J. Mogenson and F.R. Calaresu, eds.), University of Toronto Press, Toronto, 1975, pp. 412-434.
8. Walter, W.G., "An Imitation of Life," Scientific American, Vol. 182, No. 5, 1950.
9. Walter, W.G. "A Machine That Learns," Scientific American, Vol. 185, No. 2, 1951.
10. Mishkin, M. and Appenzeller, T., "The Anatomy of Memory," Scientific American, Vol. 256, No. 6, 1987.

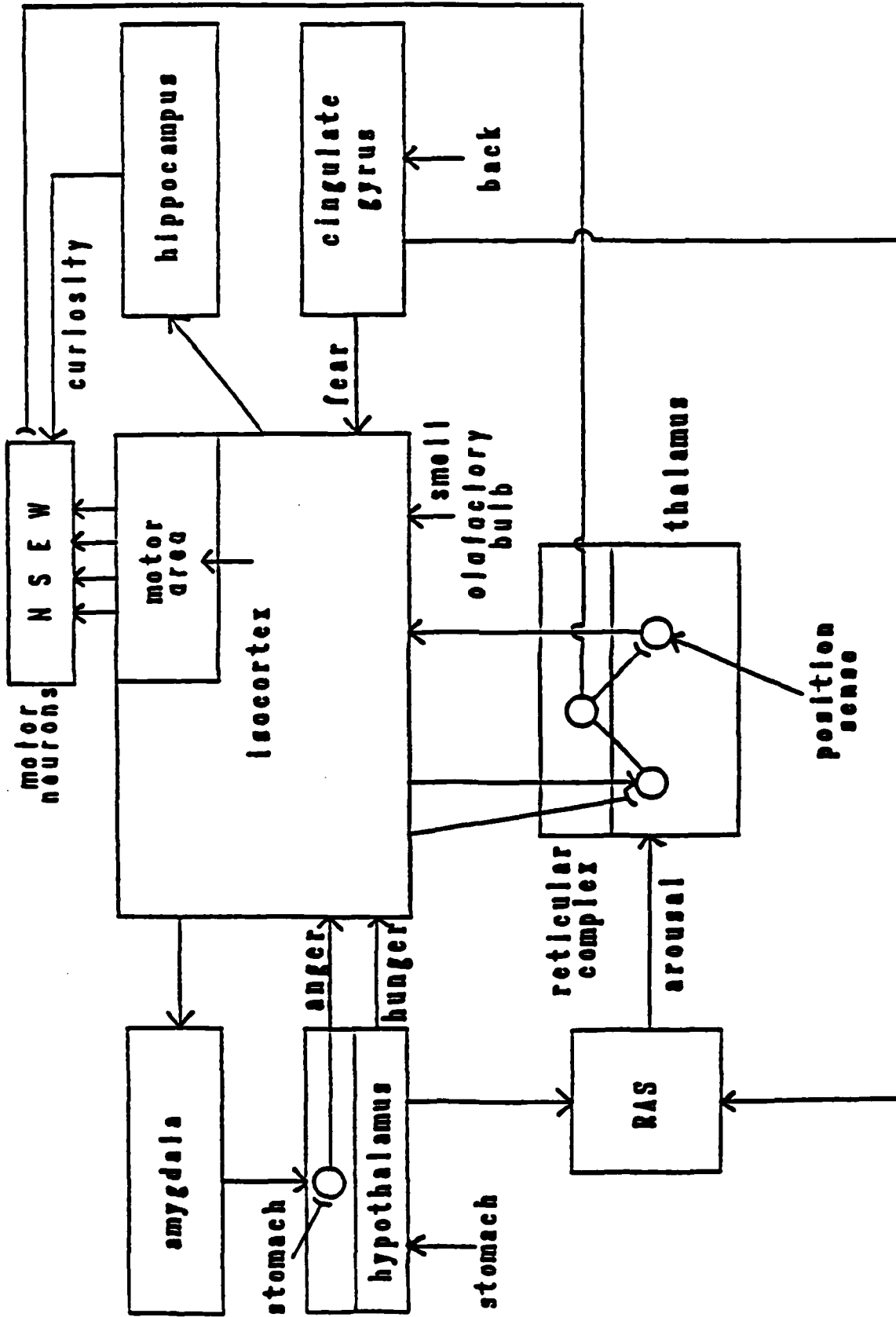

Anatomy of Paerat
Figure 1

RAS



HYPOTHALAMUS



CINGULATE GYRUS



AMYGDALA

HIPPOCAMPUS

THALAMUS

PACRAT

food

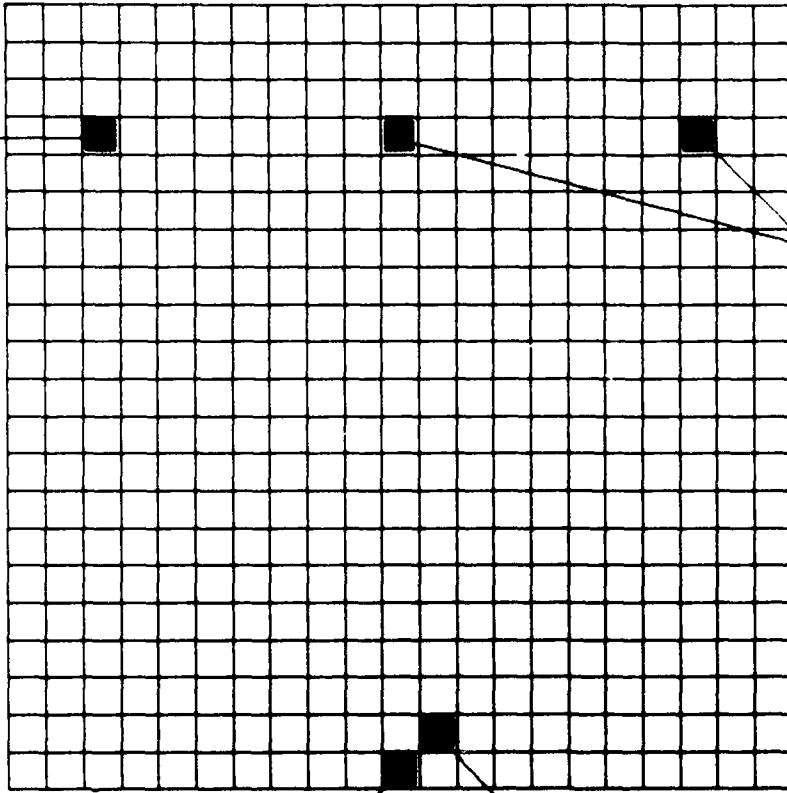

home

pacrat

food locations in other trials

TRIAL= 703

STEP= 6

Pacrat
Figure 2

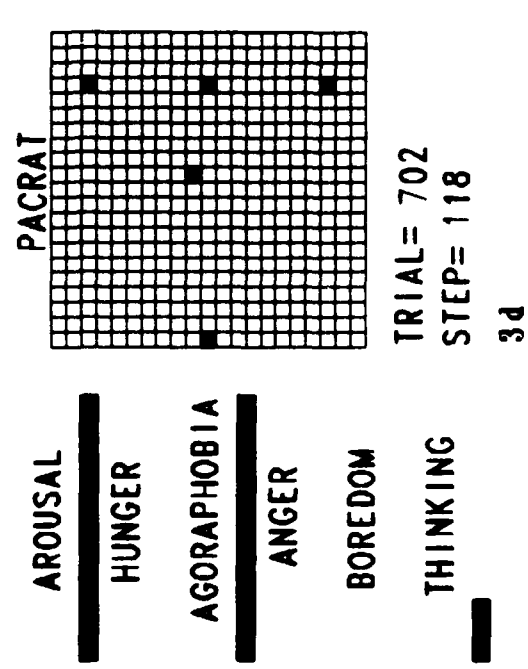
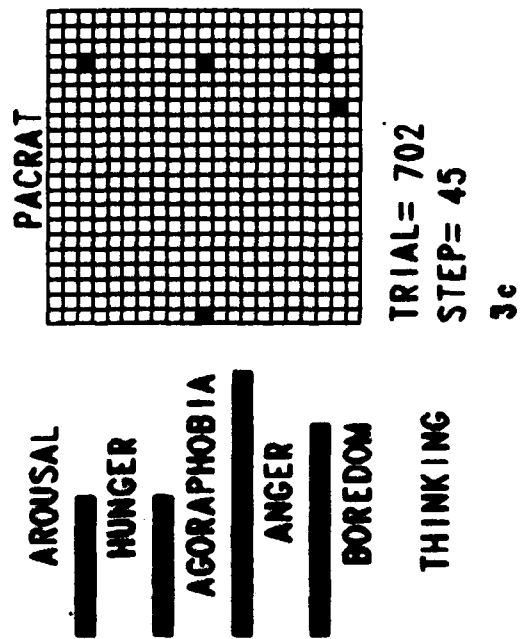
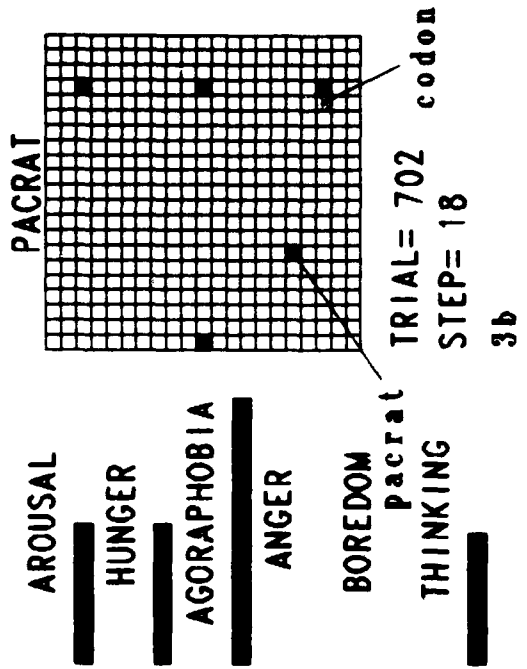
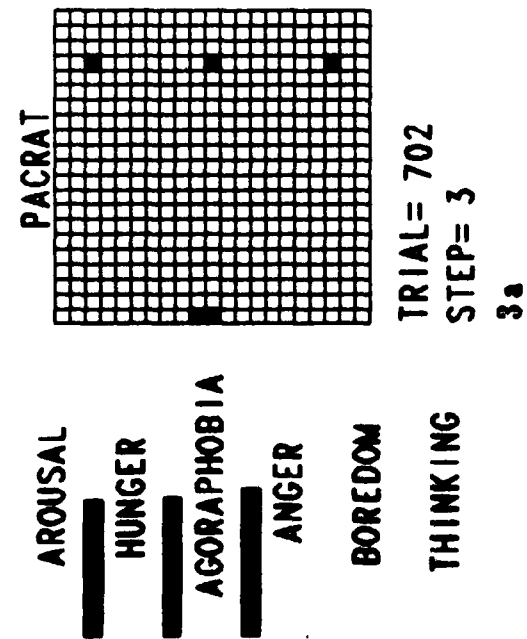

Snapshots of Dynamic Graphics Display
Figure 3

CELL ACTIVITY (PID)

i = postsynaptic , j = presynaptic

$$X_i = [AX_i + B \int_{-t}^0 (K_i - X_i)dt + CX + D*XI + E*R]^+$$

$$XI = XI + F*(\sum X_j W_{ij} - X_i)$$

X = cell activity

K_i = resting frequency

W_{ij} = synaptic weight

A,B,C,D,E,F = empirical constants

R = rectangular distribution on (0.0,1.0)

SYNAPTIC FACILITATION

$$W_{ij} = -AW_{ij} + B*H(X_i, X_j) + \Gamma(R, P)*\alpha* \int_{-t}^0 H(X_i, X_j)dt$$

$$\alpha = C\alpha + D*H(X_i, X_j)$$

$$\Gamma(R, P) = E*R + F*P$$

$$H(X_i, X_j) = [X_i - K_i]^+ [X_j - K_j]$$

A,B,C,D,E,F = empirical constants

K_i, K_j = resting frequencies

R = instantaneous reward level

P = instantaneous punishment level

R = P = 0 or E = F = 0 => Hebbian

Figure 4. Cell Activity and Synaptic Facilitation.

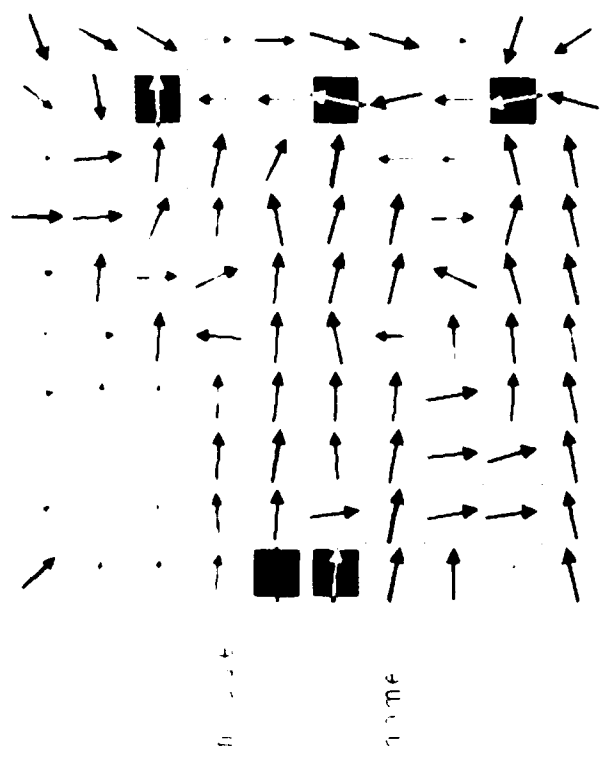

sensory neurons

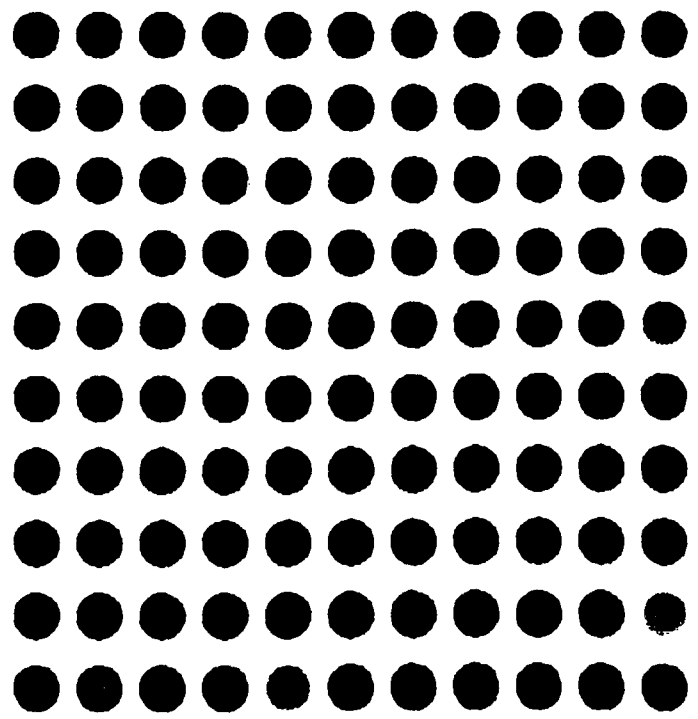

motor neurons

1/E 1 W

Snapshot of Mouse Display
Figure 5

TECHNICAL REPORT INTERNAL DISTRIBUTION LIST

	<u>NO. OF COPIES</u>
CHIEF, DEVELOPMENT ENGINEERING BRANCH	
ATTN: SMCAR-CCB-D	1
-DA	1
-DC	1
-DM	1
-DP	1
-DR	1
-DS (SYSTEMS)	1
CHIEF, ENGINEERING SUPPORT BRANCH	
ATTN: SMCAR-CCB-S	1
-SE	1
CHIEF, RESEARCH BRANCH	
ATTN: SMCAR-CCB-R	2
-R (ELLEN FOGARTY)	1
-RA	1
-RM	1
-RP	1
-RT	1
TECHNICAL LIBRARY	5
ATTN: SMCAR-CCB-TL	
TECHNICAL PUBLICATIONS & EDITING UNIT	2
ATTN: SMCAR-CCB-TL	
DIRECTOR, OPERATIONS DIRECTORATE	1
ATTN: SMCWV-OD	
DIRECTOR, PROCUREMENT DIRECTORATE	1
ATTN: SMCWV-PP	
DIRECTOR, PRODUCT ASSURANCE DIRECTORATE	1
ATTN: SMCWV-QA	

NOTE: PLEASE NOTIFY DIRECTOR, BENET LABORATORIES, ATTN: SMCAR-CCB-TL, OF ANY ADDRESS CHANGES.

TECHNICAL REPORT EXTERNAL DISTRIBUTION LIST

	<u>NO. OF COPIES</u>		<u>NO. OF COPIES</u>
ASST SEC OF THE ARMY RESEARCH AND DEVELOPMENT ATTN: DEPT FOR SCI AND TECH THE PENTAGON WASHINGTON, D.C. 20310-0103	1	COMMANDER ROCK ISLAND ARSENAL ATTN: SMCRI-ENM ROCK ISLAND, IL 61299-5000	1
ADMINISTRATOR DEFENSE TECHNICAL INFO CENTER ATTN: DTIC-FDAC CAMERON STATION ALEXANDRIA, VA 22304-6145	12	DIRECTOR US ARMY INDUSTRIAL BASE ENGR ACTV ATTN: AMXIB-P ROCK ISLAND, IL 61299-7260	1
COMMANDER US ARMY ARDEC ATTN: SMCAR-AEE	1	COMMANDER US ARMY TANK-AUTMV R&D COMMAND ATTN: AMSTA-DDL (TECH LIB) WARREN, MI 48397-5000	1
SMCAR-AES, BLDG. 321	1	COMMANDER US MILITARY ACADEMY	1
SMCAR-AET-O, BLDG. 351N	1	ATTN: DEPARTMENT OF MECHANICS WEST POINT, NY 10996-1792	
SMCAR-CC	1		
SMCAR-CCP-A	1	US ARMY MISSILE COMMAND	
SMCAR-FSA	1	REDSTONE SCIENTIFIC INFO CTR	2
SMCAR-FSM-E	1	ATTN: DOCUMENTS SECT, BLDG. 4484 REDSTONE ARSENAL, AL 35898-5241	
SMCAR-FSS-D, BLDG. 94	1		
SMCAR-MSI (STINFO)	2		
PICATINNY ARSENAL, NJ 07806-5000			
DIRECTOR US ARMY BALLISTIC RESEARCH LABORATORY ATTN: SLCBR-DD-T, BLDG. 305	1	COMMANDER US ARMY FGN SCIENCE AND TECH CTR ATTN: DRXST-SD 220 7TH STREET, N.E. CHARLOTTESVILLE, VA 22901	1
ABERDEEN PROVING GROUND, MD 21005-5066			
DIRECTOR US ARMY MATERIEL SYSTEMS ANALYSIS ACTV ATTN: AMXSY-MP	1	COMMANDER US ARMY LABCOM MATERIALS TECHNOLOGY LAB ATTN: SLCMT-IML (TECH LIB)	2
ABERDEEN PROVING GROUND, MD 21005-5071		WATERTOWN, MA 02172-0001	
COMMANDER HQ, AMCCOM ATTN: AMSMC-IMP-L	1		
ROCK ISLAND, IL 61299-6000			

NOTE: PLEASE NOTIFY COMMANDER, ARMAMENT RESEARCH, DEVELOPMENT, AND ENGINEERING CENTER, US ARMY AMCCOM, ATTN: BENET LABORATORIES, SMCAR-CCB-TL, WATERVLIET, NY 12189-4050, OF ANY ADDRESS CHANGES.

TECHNICAL REPORT EXTERNAL DISTRIBUTION LIST (CONT'D)

	<u>NO. OF COPIES</u>		<u>NO. OF COPIES</u>
COMMANDER US ARMY LABCOM, ISA ATTN: SLCIS-IM-TL 2800 POWDER MILL ROAD ADELPHI, MD 20783-1145	1	COMMANDER AIR FORCE ARMAMENT LABORATORY ATTN: AFATL/MN EGLIN AFB, FL 32542-5434	1
COMMANDER US ARMY RESEARCH OFFICE ATTN: CHIEF, IPO P.O. BOX 12211 RESEARCH TRIANGLE PARK, NC 27709-2211	1	COMMANDER AIR FORCE ARMAMENT LABORATORY ATTN: AFATL/MNF EGLIN AFB, FL 32542-5434	1
DIRECTOR US NAVAL RESEARCH LAB ATTN: MATERIALS SCI & TECH DIVISION CODE 26-27 (DOC LIB) WASHINGTON, D.C. 20375	1 1	METALS AND CERAMICS INFO CTR BATTELLE COLUMBUS DIVISION 505 KING AVENUE COLUMBUS, OH 43201-2693	1

NOTE: PLEASE NOTIFY COMMANDER, ARMAMENT RESEARCH, DEVELOPMENT, AND ENGINEERING CENTER, US ARMY AMCCOM, ATTN: BENET LABORATORIES, SMCAR-CCB-TL, WATERVLIET, NY 12189-4050, OF ANY ADDRESS CHANGES.