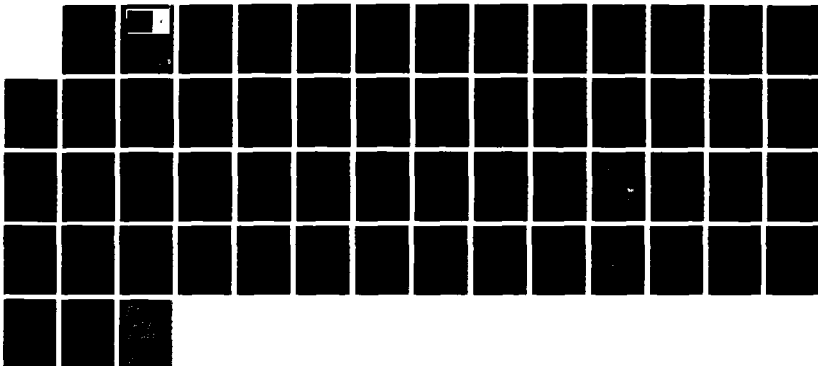


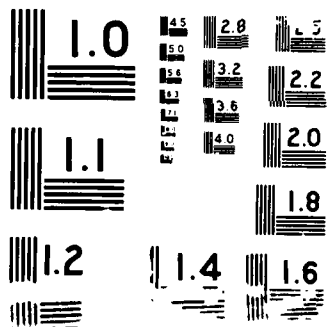
AD-R194 294

APPROXIMATE AND NUMERICAL METHODS IN ACOUSTO-OPTICS
PART 1 NORMAL INCIDEN. (U) WISCONSIN UNIV-MADISON
CENTER FOR MATHEMATICAL SCIENCES R A HERTENS ET AL.
UNCLASSIFIED DEC 87 CMS-TSR-88-28-PT-1 AFOSR-85-0263 F/G 9/6

1/1

NL







AD-A194 294

CMS Technical Summary Report #88-20

APPROXIMATE AND NUMERICAL METHODS
IN ACOUSTO-OPTICS. PART I. NORMAL
INCIDENCE OF THE LIGHT

Robert A. Mertens, Willy Hereman
and Jean-Pierre Ottoy

UNIVERSITY
OF WISCONSIN



CENTER FOR THE
MATHEMATICAL
SCIENCES

Center for the Mathematical Sciences
University of Wisconsin—Madison
610 Walnut Street
Madison, Wisconsin 53705

December 1987

(Received November 23, 1987)

Approved for public release
Distribution unlimited

Sponsored by

Air Force Office of Scientific Research
Bolling Air Force Base
Washington, DC 20332

DTIC
ELECTE
APR 19 1988
S E D

88 3 23 041

UNIVERSITY OF WISCONSIN-MADISON,
CENTER FOR THE MATHEMATICAL SCIENCES

APPROXIMATE AND NUMERICAL METHODS IN ACOUSTO-OPTICS.
PART I. NORMAL INCIDENCE OF THE LIGHT*

Robert A. Mertens**, Willy Hereman⁺,¹ and Jean-Pierre Ottoy⁺⁺

Technical Summary Report #88-20
December 1987

ABSTRACT

In the introduction of this paper the basic principles of acousto-optical diffraction in an isotropic medium are briefly reviewed. Focus is on the derivation of the Raman-Nath equations for the amplitudes of the diffracted light waves and on the physical meaning of the various parameters occurring in this diffraction problem.

In the first paragraph, three distinct methods for the numerical integration of the truncated Raman-Nath system are outlined: Raman-Nath's elementary theory, Mertens' perturbation method, and the N-th order approximation method. For each of these methods, the theoretical results are compared with experimental data.

In the second paragraph, an eigenvalue method and an operational method (due to Heaviside-Jeffreys) are used to integrate the truncated Raman-Nath system in the case of normal incidence of the light. Both methods lead to closed form expressions for the intensities of the diffracted light beams, which are easily implemented on a computer.

A comparison of the various approximation methods is presented in paragraphs three and four. Fifteen figures illustrate the validity of each method in comparison with experimental data obtained for different values of the parameters.

In paragraph five, by means of the Nth-order approximation method, some new results are obtained, indicating the relevance of the three regime parameters in distinguishing between Raman-Nath and Bragg diffraction.

In two appendices, examples are given of the exact and approximate integration of infinite and truncated Raman-Nath systems.

AMS (MOS) Subject Classifications: 34K99, 78A45; Physics Abstracts: 42.10,
42.80F,K, 43.35, 78.20H

Key Words: acousto-optics, diffraction gratings, Raman-Nath systems

*Enlarged version of a lecture given by R. A. Mertens at the Class of Sciences on May 14, 1986. Next to a survey of known methods it contains the results of recent original and unpublished research performed by the present authors.

**Instituut Theoretische Mechanica, Rijksuniversiteit Gent, Krijgslaan 281, B-900 Gent, Belgium (member of the Academy).

⁺Mathematics Department, University of Wisconsin-Madison, Madison, WI 53706.

⁺⁺Seminarie voor Toegepaste Wiskunde en Biometrie, Rijksuniversiteit Gent, Coupure Links 653, B-9000 Gent, Belgium.

¹This work was partially supported by the Air Force Office of Scientific Research under Grant No. 85-NM-0263.

CONTENTS

DANKWOORD - ACKNOWLEDGEMENTS	11
INTRODUCTION : Review of acousto-optic diffraction	1
NOMENCLATURE	9
1. APPROXIMATE SOLUTIONS OF THE RAMAN-NATH EQUATIONS	10
1.1. Raman-Nath's elementary theory	10
1.2. Perturbation method	10
1.3. The N-th order approximation method (NOA method)	11
2. SOLUTION OF THE TRUNCATED SYSTEM (45) WITH BOUNDARY CONDITIONS (46)	12
2.1. The eigenvalue problem	13
2.2. Heaviside's operational method	15
3. COMPARISON OF THE DIFFERENT APPROXIMATE METHODS WITH EXPERIMENTAL RESULTS	18
4. COMPARISON OF THE DIFFERENT APPROXIMATE METHODS TO ONE ANOTHER	19
5. FURTHER NEW RESULTS OBTAINED WITH THE NOA METHOD	20
APPENDIX A. General solution of the infinite system (33) for $\rho=0$	21
APPENDIX B. An example of the use of the eigenvalue problem developed in subsection 2.1	22
SAMENVATTING	26
REFERENCES	28

DANKWOORD - ACKNOWLEDGEMENTS

R.A.M. wenst zijn dank te betuigen aan het Nationaal Fonds voor Wetenschappelijk Onderzoek van België voor een krediet aan navorsers. W.H. drukt zijn erkentelijkheid uit aan de NAVO voor een Research Fellowship. This work was partially supported by AFOSR under Grant No. 85-NM-0263. Een bijzonder woord van dank gaat ook naar de heer V. Ros voor het tekenen van de talrijke figuren en grafieken.

Accession For	
NTIS GRA&I	<input checked="" type="checkbox"/>
DTIC TAB	<input type="checkbox"/>
Unannounced	<input type="checkbox"/>
Justification	
By _____	
Distribution/	
Availability Codes	
Dist	Avail and/or Special
A-1	



INTRODUCTION

Review of acousto-optic diffraction

The vibration of a piezo-electric transducer, driven by a radio frequency electric signal, generates a progressive ultrasonic wave into a cell of acousto-optic (AO) material. As sound passes through the medium, it is characterized by regularly alternating compressions and rarifactions. These alterations of the internal strain cause a periodic variation of the optical index of refraction of the transparent medium. This type of coupling is commonly called the photoelastic or elasto-optic effect.

To light impinging on the cell, the index variation appears as a slowly moving volumetric phase grating, with spacing equal to the acoustic wavelength and grating depth proportional to the amplitude of the acoustic wave.

Considering Fig. 1, where the angle φ between the incident monochromatic light and the acoustic wavefronts is close to zero, we observe that the emerging light is diffracted into a set of multiple beams (orders at the output).

The diffracted beams are shifted up and down in frequency by an amount equal to a multiple of the acoustic frequency. The deflection angles of the various emerging light rays also depend on the ultrasonic frequency, while their intensities (hence, the number of output orders) are primarily determined by the width L of the cell and the strength of the sound field. The diffracted light beams can be imaged on a photographic plate (using appropriate optical instrumentation) so forming a diffraction spectrum (Fig. 2).

To be more precise, one has to distinguish between two cases, as illustrated in Figs. 3a and 3b. If the input light is incident perpendicularly to a rather narrow acoustic cell, the diffraction pattern shows a central order of undiffracted light and many side order of diffracted light. This case of multi-order diffraction (illustrated in Fig. 3a) is commonly called Raman-Nath diffraction (RN diffraction). It is achieved for rather intense sound fields in the lower frequency range ($<400\text{MHz}$).

For thick sound fields of higher frequencies, essentially only two diffraction orders (zeroth and first) will exist, provided the input light intercepts the sound cell at the so-called Bragg angle, as shown in Fig. 3b. This case of two-order diffraction (referred to as Bragg diffraction) is applied in a majority of commercial acousto-optics devices (Bragg cells).

The fact that acousto-optic devices (either operating in the Raman-Nath or in the Bragg diffraction regime) have the capability of altering the position, frequency, amplitude and phase of a (laser) light beam, has resulted in a variety

of applications in signal processing and optical communication.

Before proceeding to a brief discussion of the relative amplitudes of the diffracted light beams, let us examine their directions of propagation and frequencies more closely.

The easiest way to derive the deflection angles and the frequencies of the scattered light beams, is to interpret the electromagnetic-acoustic interaction as a photon-phonon collision process [8,13,23]. Recalling two elementary concepts of quantum wave mechanics, i.e. frequency is proportional to energy, and wave number is proportional to momentum, we express conservation of energy and momentum for the interaction of the particles. Generally taking into account multiple interactions, reveals that the scattered light must emerge in a spectrum whose frequencies and wavenumbers are determined by the conditions :

$$\omega_n = \omega - n\omega^* , \quad (1)$$

$$\mathbf{k}_n = \mathbf{k} - n\mathbf{k}^* , \quad n = 0, \pm 1, \pm 2, \dots . \quad (2)$$

Here ω and \mathbf{k} refer to the incident light wave; ω_n and \mathbf{k}_n to the n -th order emerging light wave, while the sound has an angular frequency ω^* and a wavevector \mathbf{k}^* . Note that all symbols refer to the characteristics inside the acoustic medium.

Restricting ourselves to the case of one diffracted order ($n=1$), and assuming exact momentum matching and downshifted interaction, the corresponding wave vector diagram is easily drawn (Fig. 4). Since $|\mathbf{k}^*| \ll |\mathbf{k}|$, this triangle is isosceles, i.e. $|\mathbf{k}_1| \approx |\mathbf{k}|$. It follows that $\theta_1 = -\varphi_{BR}$, where φ_{BR} satisfies the relation

$$\sin\varphi_{BR} = \frac{k^*}{2k} = \frac{\lambda}{2\lambda^*} = \frac{\lambda v^*}{2V} , \quad (3)$$

wherein V is the sound velocity.

This condition, defining the Bragg angle φ_{BR} , is similar to the one used for X-ray diffraction from the periodic arrangement of atoms in a crystal. As a consequence, the incident light beam is deflected from its original direction through the angle $2\varphi_{BR}$. If we introduce angle θ_n for the direction of propagation of the n -th order light beam, then from (2) we obtain

$$\theta_n \approx \varphi - \frac{n k^*}{k} = \varphi - \frac{n \lambda}{\lambda^*} , \quad n = 0, \pm 1, \pm 2, \dots , \quad (4)$$

provided all angles are sufficiently small.

The reader should be warned that the labelling of the diffraction orders throughout this paper is consistent with the one in Raman-Nath's original work [42,43,48-52]. Hence, the positive label n will refer to the diffracted light beam which is downshifted in frequency by an amount $n\omega^*$, as in (1). In theoretical as well as technical papers, written by (electrical) engineers, the positive phasor convention is used [25], consequently the positive label n would refer to the frequency upshifted light beam of order n ($\omega_n = \omega + n\omega^*$ would replace (1)).

Anyway, the frequencies and directions of propagation of the diffracted light waves are correctly and simply determined by (1) and (4), leaving only the amplitudes and thereafter the intensities of the diffraction orders to be calculated.

In a series of extraordinary papers [42,43,48-52], Raman and Nagendra Nath use at first geometrical arguments and later on a differential equation method to determine the amplitudes of the diffracted light beams. In their elementary theory, Raman and Nagendra Nath [48] assumed the diffraction effect to be due to a simple phase corrugation of the incident light caused by an acoustic variation of the index of refraction. For engineers, phase modulated waves are known to be composed of a carrier and a set of sidebands separated by ω^* , the amplitudes of which are the Besselfunctions J_n of the first kind and integral order n . In mathematical terms, the modulated output electric field can be represented as

$$E(x,z,t) = \chi(x,z,t) \exp i(\omega t - kz) , \quad (5)$$

assuming normal incidence for the input light. If we restrict ourselves to the case of a simple sinusoidal sound field, the dielectric permittivity of the disturbed medium can be written as

$$\epsilon(x,t) = \epsilon_0 [\epsilon_r + \epsilon_1 \sin(\omega^* t - k^* x)] . \quad (6)$$

where ϵ_0 is the dielectric constant of vacuum and ϵ_1 is the peak variation of the relative permittivity ϵ_r of the medium.

For pure phase modulation due to the progressive sound field (6), $\chi(x,z,t)$ can be expressed as an exponential function with purely imaginary argument, i.e.

$$\chi(x, z, t) = \exp\left[\frac{ik\epsilon_1 z}{2\epsilon_r} \sin(k^*x - \omega^*t)\right] . \quad (7)$$

Using the well-known formula of Jacobi [54]

$$\exp[(\pm i \cos x)z] = \sum_{n=-\infty}^{+\infty} (\pm i)^n J_n(z) \exp(inx) , \quad (8)$$

which generates the Bessel functions of first kind and integer order n , (7) becomes

$$\chi(x, z, t) = \sum_{n=-\infty}^{+\infty} J_n\left(\frac{k\epsilon_1 z}{2\epsilon_r}\right) \exp[in(k^*x - \omega^*t)] . \quad (9)$$

Substituting this result into (5) yields the Fourier expansion of the electric field in the exit plane $z=L$:

$$E(x, L, t) = \sum_{n=-\infty}^{+\infty} J_n(v) \exp[i(nk^*x - kL)] \exp i[(\omega - n\omega^*)t] . \quad (10)$$

In (10), the constant

$$v = \frac{k\epsilon_1 L}{2\epsilon_r} = \frac{\pi\epsilon_1 L}{\epsilon_r \lambda} \quad (11)$$

is known as the Raman-Nath parameter (RN parameter) and it is a measure of the strength of the acoustic modulation of the light.

From (10) we learn that the amplitude of the n -th order diffracted light beam simply is $J_n(v)$; hence the diffraction order irradiance I_n is

$$I_n(v) = J_n^2(v) , \quad n = 0, \pm 1, \pm 2, \dots . \quad (12)$$

Raman and Nagendra Nath [49] later generalized their phase modulation model to account for oblique incidence. Without conceptual changes one can straightforwardly obtain the closed form expression for the intensity of the n -th order diffracted light beam

$$I_n(v') = J_n^2\left[v' \operatorname{sinc}\left(\frac{L \tan \varphi}{\lambda^*}\right)\right] , \quad (13)$$

with

$$v' = \frac{v}{\cos \varphi} = \frac{k\epsilon_1 L}{2\epsilon_r \cos \varphi} = \frac{\pi\epsilon_1 L}{\epsilon_r \lambda \cos \varphi} \quad (14)$$

and

$$\text{sinc } x = \frac{\sin \pi x}{\pi x} . \quad (15)$$

In a broader perspective, Raman and Nagendra Nath [42,51,52] no longer restricted the diffraction effect to be exclusively due to phase modulation but took also amplitude modulation into account. This led to their so-called generalized theory. Let us give a synopsis of this since then well developed approach.

For oblique incidence, instead of (5) we now will have

$$E(x,z,t) = \chi(x,z,t) \exp i[\omega t - k(x \sin\varphi + z \cos\varphi)] \quad (16)$$

where the amplitude factor $\chi(x,z,t)$ is no longer restricted to the form (7), but still must show the same periodic structure as the disturbing sound wave. Consequently, by Fourier expansion the function $\chi(x,z,t)$ can be decomposed into a sum of plane wave

$$\chi(x,z,t) = \sum_{n=-\infty}^{+\infty} \phi_n(z) \exp in(k^*x - \omega^*t) , \quad (17)$$

hence,

$$E(x,z,t) = \sum_{n=-\infty}^{+\infty} \phi_n(z) \exp i[(nk^* - k \sin\varphi)x - kz \cos\varphi] \exp i(\omega - n\omega^*)t . \quad (18)$$

From (18) it is easy to rederive (1) and (2), whereas the unknown amplitudes $\phi_n(z)$ will follow from inserting the expansion into the appropriate wave equation for the medium with slowly varying permittivity (6), i.e.

$$\frac{\partial^2 E}{\partial x^2} + \frac{\partial^2 E}{\partial z^2} = \mu_0 \epsilon(x,t) \frac{\partial^2 E}{\partial t^2} . \quad (19)$$

This substitution results in the celebrated Raman-Nath equations (called from now on RN equations),

$$2 \frac{d\phi_n}{d\zeta'} - (\phi_{n-1} - \phi_{n+1}) = in(np - 2a \sin\varphi) \phi_n , \quad n = 0, \pm 1, \pm 2, \dots , \quad (20)$$

linking the amplitudes of neighbouring diffraction orders in a difference-differential form. Expressing that there is no loss of energy in this AO diffraction effect, provides system (20) with the appropriate (normalized) boundary conditions

$$\phi_n(0) = \delta_{n0} , \quad n = 0, \pm 1, \pm 2, \dots . \quad (21)$$

In (20), we introduced the phase variable

$$\zeta' = \frac{k\epsilon_1 z}{2\epsilon_r \cos\varphi} = \frac{v' z}{L}, \quad (22)$$

the diffraction regime parameter

$$\rho = \frac{2\epsilon_r \lambda^2}{\epsilon_1 \lambda^{*2}}, \quad (23)$$

and

$$a = \frac{2\epsilon_r \lambda}{\epsilon_1 \lambda^{*2}}, \quad (24)$$

the latter two containing the ratio of wavelengths of light and ultrasound.

For a physical interpretation of the parameter a , we define the Bragg angle $\varphi_{BR}^{(n)}$ of higher order in the familiar way by

$$\sin \varphi_{BR}^{(n)} = \frac{nk^{*2}}{2k} = \frac{n\lambda}{2\lambda^{*2}} = \frac{n\rho}{2a}, \quad n = 0, \pm 1, \pm 2, \dots \quad (25)$$

Then, (20) can be rewritten as

$$2 \frac{d\phi_n}{d\zeta'} - (\phi_{n-1} - \phi_{n+1}) = i n^2 \rho \left(1 - \frac{\sin \varphi}{\sin \varphi_{BR}^{(n)}} \right) \phi_n. \quad (26)$$

Hence, it is clear that $\sin \varphi$ is a measure of the incidence angle in units of the Bragg angle $\varphi_{BR}^{(n)}$.

After Klein and Cook [21], quite often, the parameter

$$Q = \rho v = \frac{2\pi\lambda L}{\lambda^{*2}}, \quad (27)$$

is introduced to divide between Bragg and Raman-Nath diffraction regimes. Since this parameter is independent of the amplitude ϵ_1 of the disturbing sound wave, Q is necessary but not sufficient for an accurate distinction between both regimes [12,15,16,17,18,30,40,41,47,53]. Furthermore, scrutinizing the paper of Klein and Cook reveals, that one should use [15,16,17,29,53]

$$Q' = \frac{Q}{\cos\varphi} = \rho v', \quad (28)$$

rather than Q to deal with cases of oblique incidence.

In our previous work, we mainly used ρ as a regime parameter, since this one gives a measure of the amplitude grating impressed on the light wave. Indeed, returning to (20), for $\rho = 0$ we obtain the well-known Besselfunction solution

$$\phi_n(\zeta') = J_n\left(\frac{\sin b\zeta'}{b}\right) \exp(-inb\zeta') , \quad (29)$$

with

$$b = \frac{1}{2} a \sin\varphi . \quad (30)$$

Under the supplementary restriction of normal incidence ($\varphi=0$), (26) reduces to

$$\phi_n(\zeta) = J_n(\zeta) , \quad (31)$$

with

$$\zeta = \frac{k\epsilon_1 z}{2\epsilon_r} = \frac{\pi\epsilon_1 z}{\epsilon_r \lambda} = \frac{vz}{L} . \quad (32)$$

From (29), resp. (31), at $z=L$ we rederive the results (13), resp. (12), as obtained from RN's early phase modulation model.

For normal incidence, we obviously have $\zeta' = \zeta$, $v' = v$ and $Q' = Q$.

Let us remark that, recently, there was a revived interest in equations of the RN type, not only for their relevance to acousto-optical problems [27] and holography [14,28], but also to the study of other physical phenomena, such as stimulated Compton scattering [6], stimulated Cherenkov emission, and to the theory of the free electron laser [9].

In the following we shall restrict ourselves to normal incidence of the light, i.e. $\varphi = 0$, so that the system of RN equations reads

$$2\frac{d\phi_n}{d\zeta} - (\phi_{n-1} - \phi_{n+1}) = in^2\rho\phi_n , \quad n = 0, \pm 1, \pm 2, \dots , \quad (33)$$

with boundary conditions

$$\phi_n(0) = \delta_{n0} , \quad n = 0, \pm 1, \pm 2, \dots . \quad (34)$$

It has been shown [32,38] in the case of normal incidence, that

$$\phi_{-n}(\zeta) = (-1)^n \phi_n(\zeta) , \quad (35)$$

so that the system (33) can be simplified into

$$\frac{d\phi_0}{d\zeta} + \phi_1 = 0, \quad (36)$$

$$2\frac{d\phi_n}{d\zeta} - (\phi_{n-1} - \phi_{n+1}) = in^2\rho\phi_n, \quad n = 1, 2, \dots, \quad (37)$$

with boundary conditions

$$\phi_n(0) = \delta_{n0}, \quad n = 0, 1, 2, \dots \quad (38)$$

Eq. (32) has as immediate consequence that

$$I_{-n}(\zeta) = I_n(\zeta), \quad (39)$$

meaning that for normal incidence of the light, the diffraction pattern is symmetric with respect to the zero order.

The latter system has been solved exactly by a method called the "generating function method" (GFM) [26,37], leading to an infinite series expansion for the amplitudes $\phi_n(\zeta)$ containing the Fourier coefficients of the even periodic Mathieu functions $ce_{2n}(x,q)$. Later an equivalent method, the "modified generating function method" (MGFM) [15,16,17,34,35,36] has been devised, starting directly from the wave equation (19), without passing through the RN equations, and giving the same solution. The exact solution obtained by those methods does not give expressions in closed form, and in order to perform numerical calculations, one should have the disposal of extensive tables of the Fourier coefficients of the periodic Mathieu functions. The existing tables of those functions are either too restricted [1] or are related to Mathieu functions which are not yet expressed in the canonical form [7] used nowadays [2,31]. This is the reason why in the present study we shall pay close attention to approximate and numerical solutions of the system (36,37) with boundary conditions (38).

In Section 1 we give a survey of some approximate methods. Section 2 considers in detail one of those methods (the N-th order approximation method) which, reduced to an eigenvalue problem, is especially suited for numerical treatment. In the next Section the results are compared with experimental data of Klein and Hiedemann [20,22] and in Section 4 comparison is made with other approximations. Finally in Section 5 some further considerations with respect to the N-th order approximation method are expounded.

N O M E N C L A T U R E

ϵ_0, μ_0	permittivity, magnetic permeability of vacuum
$\lambda, k, \nu, \omega, u$	wave length, wave number, frequency, angular frequency, speed of <u>light</u> (in medium)
$\lambda^*, k^*, \nu^*, \omega^*, V$	wave length, wave number, frequency, angular frequency, speed of <u>sound</u> (in medium)
$\epsilon(x, t)$	dielectric permittivity of the disturbed medium
ϵ_r	relative permittivity (undisturbed medium)
ϵ_1	maximum variation of the linear relative permittivity (disturbed medium)
E	amplitude of the (scattered) electric field (disturbed medium)
L	acousto-optic interaction length along the z-axis
x	direction of sound propagation
z	direction of light propagation (at normal incidence)
t	time
φ	angle of incidence of light (in medium)
n	order of diffraction
$\varphi_{BR}^{(n)}$	Bragg angle of order n (in medium)
θ_n	deflection angle of order n (in medium)
ϕ_n	amplitude (complex) of diffracted light wave of order n
$\bar{\phi}_n$	complex conjugate of ϕ_n
I_n	intensity of spectral line of order n
$J_n(z)$	Bessel function of the first kind of order n
ν	Raman-Nath parameter or peak phase deviation
ρ	regime parameter
Q	Klein-Cook parameter
AO	acousto-optic
RN	Raman-Nath
GFM	generating function method
MGFM	modified generating function method

1. APPROXIMATE SOLUTIONS OF THE RAMAN-NATH EQUATIONS (36,37)

1.1. Raman-Nath's elementary theory

The most simple approximation is obtained by putting $\rho = 0$. In this case the infinite system (36,37) with boundary conditions (38), or the equivalent system (33) with boundary conditions (34), has an exact solution (cf. Eq.(31))

$$\phi_n(v) = J_n(v), \quad n = 0, \pm 1, \pm 2, \dots, \quad (40)$$

giving the intensities

$$I_n(v) = I_{-n}(v) = J_n^2(v), \quad n = 0, 1, 2, \dots \quad (41)$$

A proof based on the general solution of the system (33) with $\rho = 0$ is given in Appendix A.

A comparison of this elementary theory with experiment was given by Klein [20] and by Klein and Hiedemann [22] where zeroth and first order light intensities vs v were plotted together with corresponding intensity measurements for $Q=0.94$ ($L=3.0\text{cm}$), 1.26 ($L=4.0\text{cm}$) and 1.48 ($L=4.7\text{cm}$) (cf. Figs. 5(p.), 6(p.), 7(p.), 8(p.), 9(p.), 10(p.)).

The approximate theory gives acceptable results only if $v \lesssim 2$ for $Q=0.94$, $v \lesssim 1.5$ for $Q=1.26$ and $v \lesssim 1.3$ for $Q=1.48$. Those conditions are in agreement with the theoretical limits established by Extermann and Wannier [10] as $Q \ll 2$ and $Qv < 2$.

1.2. Perturbation method

In order to obtain an improvement of RN's elementary theory a perturbation method was developed by Mertens [32], putting

$$\phi_n(\zeta) = J_n(\zeta) + \rho \psi_{n1}(\zeta) + \rho^2 \psi_{n2}(\zeta) + \dots, \quad (42)$$

where the functions $\psi_{n1}(\zeta)$ and $\psi_{n2}(\zeta)$ could be expressed as converging power series in ζ . Since $\psi_{nk}(\zeta)$ is of the form $\zeta^k \alpha_{nk}(\zeta)$, Miller and Hiedemann [39] wrote this solution as

$$\phi_n(v) = J_n(v) + Q \alpha_{n1}(v) + Q^2 \alpha_{n2}(v) + \dots \quad (43)$$

Later, using the generating function method, Kuliasko et al [26] were able to express the solution up to the second-order in ρ in a closed form, leading to the compact formula for the intensities

$$I_n(v) = J_n^2(v) - \frac{1}{720} \rho^2 v^2 [(7n^2 - 9v^2) J_n^2(v) + (16n^2 - 3)v J_n(v) J_n'(v) - 5v^2 J_n'^2(v)] , \quad n=0, \pm 1, \pm 2, \dots, \quad (44)$$

where $J_n'(v) = \left. \frac{dJ_n(\zeta)}{d\zeta} \right|_{\zeta=v}$.

One of the principal aims of Klein [20] and Klein and Hiedemann [22] was the comparison of their measured light intensities with the intensities obtained by the present perturbation theory. For $Q=0.94$ there was satisfactory agreement between experiment and theory for values of v up to 6.5 (cf. Figs. 5(p.), 8(p.)); for $Q=1.26$ there was agreement for $v \lesssim 4.5$ (cf. Figs. 6(p.), 9(p.)); and for $Q=1.48$ the agreement was rather poor, particularly for values of v larger than 3.5 (cf. Figs. 7(p.), 10(p.)). Klein and Hiedemann conclude that the theory gives acceptable results for experimental arrangements described by $Qv < 8$ and that an upper limit of usefulness of the theory, allowing a reasonable range of values of v , is $Q < 1.25$. Anyhow, the perturbation method means a substantial improvement with respect to the results obtained by the elementary RN theory.

1.3. The N-th order approximation method (NOA method)

We shall now discuss a totally different approximate method for solving the system (36,37); it will form the basis of our numerical treatment of the problem. In this framework we neglect the energy in the diffraction orders higher than N , i.e. $\phi_{\pm(N+1)} = \phi_{\pm(N+2)} = \dots = 0$, so that the infinite system (36,37) is replaced by the following truncated system of $N+1$ equations:

$$\begin{aligned} \frac{d\phi_0}{d\zeta} + \phi_1 &= 0 , \\ 2\frac{d\phi_n}{d\zeta} - \phi_{n-1} + \phi_{n+1} &= in^2 \rho \phi_n , \quad n = 1, 2, \dots, N-1 , \\ 2\frac{d\phi_N}{d\zeta} - \phi_{N-1} &= iN^2 \rho \phi_N , \end{aligned} \quad (45)$$

with the boundary conditions

$$\phi_n(0) = \delta_{n0} \quad , \quad n = 0, 1, 2, \dots, N \quad . \quad (46)$$

This procedure, called N-th order approximation (NOA) method was introduced by Nagendra Nath [43] for N=1 (and, hence, restricted to the Bragg diffraction regime). It was extended for arbitrary N by Mertens [33] in 1962 for the more involved problem of superposed ultrasonic waves. In that paper the denomination NOA method was coined. Numerically, however, the method had to be restricted to N=2 (i.e. five equations), according to the computer facilities at that time. In two recent publications [4,5], Blomme and Leroy derived finite analytical expressions for the intensities using respectively N=2 and N=3. A profound discussion of the accuracy of those 2OA and 3OA methods, in a wide range of the parameters ρ and v , has been given in those papers. To end this Section we give the formulae obtained by Nagendra Nath for N=1, expressed in ρ or equivalently in Q ($=\rho v$)

$$\begin{aligned} I_0(v) &= 1 - \frac{8}{\rho^2+8} \sin^2 \frac{v}{4} \sqrt{\rho^2+8} = 1 - \frac{8v^2}{Q^2+8v^2} \sin^2 \frac{\sqrt{Q^2+8v^2}}{4} \quad , \\ I_{\pm 1}(v) &= \frac{4}{\rho^2+8} \sin^2 \frac{v}{4} \sqrt{\rho^2+8} = \frac{4v^2}{Q^2+8v^2} \sin^2 \frac{\sqrt{Q^2+8v^2}}{4} \quad . \end{aligned} \quad (47)$$

A derivation of those formulae, using one of the methods exposed in the next Section is given in Appendix B.

Those expressions will be useful later for comparison with the numerical results. At that place their validity shall also be discussed.

2. SOLUTION OF THE TRUNCATED SYSTEM (45) WITH BOUNDARY CONDITIONS (46)

To integrate truncated RN systems several methods have been proposed, e.g. an operator technique introduced by Benlarbi and Solymar [3] (extremely useful to treat higher-order Bragg diffraction) and a Laplace-transform method [27]. In this paper we will use two straightforward techniques :

- (1) an eigenvalue method, leading to a characteristic equation of degree N+1, with real roots;
- (2) the operational method of Heaviside-Jeffreys [19], leading to expressions for the amplitudes in terms of determinants.

2.1. The eigenvalue problem

Assuming a solution of system (45) in the natural form

$$\phi_n = a_n \exp\left(\frac{1}{2}is\zeta\right)$$

the corresponding eigenvalue problem would have a non-Hermitian matrix, the condition for real eigenvalues thus being abolished. This slight problem, which is due to the use of symmetry relation (35), can be easily overcome by introducing a similarity transformation, realized by directly modifying the solution into

$$\phi_0 = \sqrt{2} a_0 \exp\left(\frac{1}{2}is\zeta\right), \quad (48)$$

$$\phi_n = a_n \exp\left(\frac{1}{2}is\zeta\right), \quad n = 1, 2, \dots, N.$$

Substitution of (48) into system (45) leads to a system of linear homogeneous equations for a_0, a_1, \dots, a_N , which may be written in matrix form as

$$(\mathbf{M} - s\mathbf{I}) \cdot \mathbf{a} = \mathbf{0}, \quad (49)$$

where \mathbf{I} is the $(N+1) \times (N+1)$ unit matrix, $\mathbf{a}^T = (a_0 \ a_1 \ \dots \ a_N)$ and

$$\mathbf{M} = \begin{bmatrix} 0 & i\sqrt{2} & 0 & \cdot & \cdot & \dots & \dots & \cdot & \cdot & \cdot & 0 \\ -i\sqrt{2} & \rho & i & 0 & \cdot & \dots & \dots & \cdot & \cdot & \cdot & 0 \\ 0 & -i & 4\rho & i & 0 & \dots & \dots & \cdot & \cdot & \cdot & 0 \\ \vdots & \cdot & \cdot & \cdot & \cdot & \cdot & \cdot & \cdot & \cdot & \cdot & \vdots \\ 0 & \cdot & \cdot & \cdot & \cdot & \dots & 0 & -i & n^2\rho & i & 0 & \dots & \cdot & \cdot & \cdot & 0 \\ \vdots & \cdot & \cdot & \cdot & \cdot & \cdot & \cdot & \cdot & \cdot & \cdot & \cdot & \cdot & \cdot & \cdot & \cdot & \vdots \\ 0 & \cdot & \cdot & \cdot & \cdot & \dots & \dots & 0 & -i & (N-1)^2\rho & i & \dots & \dots & \dots & \dots & 0 \\ 0 & \cdot & \cdot & \cdot & \cdot & \dots & \dots & \cdot & 0 & -i & N^2\rho & \dots & \dots & \dots & \dots & 0 \end{bmatrix} \quad (50)$$

is a $(N+1) \times (N+1)$ Hermitian matrix, the eigenvalues of which are real [11].

In order to obtain a nonzero solution \mathbf{a} of the linear homogeneous system (49),

the determinant of the coefficients must vanish :

$$\det(M-sI) = 0 . \quad (51)$$

In other words, we ought to calculate the $N+1$ real eigenvalues s_k ($k=1,2,\dots,N+1$) of the Hermitian matrix M . The eigenvector $\mathbf{a}^{(k)}$, with $\mathbf{a}^{(k)T} = (a_0^{(k)} a_1^{(k)} \dots a_N^{(k)})$, associated with the eigenvalue s_k will then be determined by the linear homogeneous system

$$(M-s_k I) \cdot \mathbf{a}^{(k)} = 0 . \quad (52)$$

From the structure of the system (52), we may see that $a_0^{(k)} \neq 0$ and that $a_n^{(k)}$ may be chosen real if n is even, and purely imaginary if n is odd. Furthermore, we can choose $a_0^{(k)} = \sqrt{2}/2$ ($k=1,2,\dots,N+1$) since any eigenvector is only determined up to an arbitrary factor. The general solution of the truncated linear differential system (45) may then be written as [11]

$$\phi_0 = \sum_{k=1}^{N+1} c_k \exp\left(\frac{1}{2} i s_k \zeta\right) , \quad (53)$$

$$\phi_n = \sum_{k=1}^{N+1} c_k a_n^{(k)} \exp\left(\frac{1}{2} i s_k \zeta\right) , \quad n = 1, 2, \dots, N , \quad (54)$$

where the $N+1$ constants c_k are real (as a consequence of the choices of $a_0^{(k)}$ and $a_n^{(k)}$). These constants follow from imposing the boundary conditions (46) to (53) and (54) :

$$\sum_{k=1}^{N+1} c_k = 1 , \quad \sum_{k=1}^{N+1} c_k a_n^{(k)} = 0 , \quad n = 1, 2, \dots, N . \quad (55)$$

Finally we can calculate the intensities in $z=L$:

$$I_0(v) = \phi_0(v) \bar{\phi}_0(v) = 1 - 4 \sum_{\substack{j,k=1 \\ j < k}}^{N+1} c_j c_k \sin^2(s_j - s_k) \frac{v}{4} , \quad (56)$$

$$I_{\pm n}(v) = \phi_{\pm n}(v) \overline{\phi_{\pm n}(v)} = -4 \sum_{\substack{j,k=1 \\ j < k}}^{N+1} c_j c_k a_n^{(j)} \overline{a_n^{(k)}} \sin^2(s_j - s_k) \frac{v}{4} , \quad (57)$$

$n = 1, \dots, N ,$

where the bar stands for complex conjugate.

Needless to say that the characteristic equation (51), of degree $N+1$ in s , can only be solved analytically for $N \leq 3$. Thus only in the latter cases explicit analytical expressions for the intensities can be obtained [4,5,33,43]. Otherwise the problem has to be treated numerically using the following steps :

- (i) determine the eigenvalues and eigenvectors of the matrix M ;
- (ii) next solve the linear system (55) for c_k ;
- (iii) substitute the results obtained from (i) and (ii) into Eqs. (56) and (57).

We remark that the solution scheme of the eigenvalue problem sketched above is particularly suited to computer algorithms.

2.2. Heaviside's operational method

Now we will apply Heaviside's operational method to the truncated system (45). After Jeffreys [19, p.237] we write p for $d/d\zeta$ and interpret p^{-1} as the operation of definite integration

$$p^{-1}f(\zeta) = \int_0^{\zeta} f(z)dz . \quad (58)$$

The resulting subsidiary equations [19], which take the boundary conditions (46) into account, are

$$\begin{aligned} -s\phi_0 + 2i\phi_1 &= -s \\ (\rho n^2 - s)\phi_n - i\phi_{n-1} + i\phi_{n+1} &= 0 \quad , \quad n = 1, 2, \dots, N , \\ (\rho N^2 - s)\phi_N - i\phi_{N-1} &= 0 \end{aligned} \quad (59)$$

with $s = -2ip$. This system is now to be solved as if p (or s) were a number. In compact notation the system (59) can be written as

$$D\phi = -sE , \quad (60)$$

where the almost Hermitian $(N+1) \times (N+1)$ matrix D is related to M through a similarity transformation

$$D(s) = P(M - sI)P^{-1} , \quad (61)$$

with $P = I + R$, such that all elements r_{ij} of R vanish, except $r_{11} = \sqrt{2} - 1$.

Furthermore we have $\Phi^T = (\phi_0 \phi_1 \phi_2 \dots \phi_N)$ and $E^T = (1 \ 0 \ \dots \ 0)$, the latter vector expressing the boundary condition. From (60) we obtain the formal solution of the problem :

$$\Phi = -sD^{-1}E, \quad (62)$$

where D^{-1} is the inverse of D . So, one explicitly has

$$\phi_n = \frac{-sD_{1,n+1}}{\det D}, \quad n = 0, 1, \dots, N, \quad (63)$$

where $D_{1,n+1}$ stands for the cofactor of the element $d_{1,n+1}$ of D ($n=0, 1, 2, \dots, N$). Substituting $s = -2ip$ in (63) we find

$$\phi_n = \frac{2pF_{1,n+1}(p)}{F(p)} \quad (n=0, 1, \dots, N-1), \quad \phi_N = \frac{2p}{F(p)}, \quad (64)$$

where $F_{1,n+1}(p)$ is the determinant

$$\begin{vmatrix} 2p-i(n+1)^2p & 1 & 0 & \dots & \dots & \dots & 0 \\ -1 & 2p-i(n+2)^2p & 1 & 0 & \dots & \dots & 0 \\ 0 & -1 & \dots & \dots & \dots & \dots & 0 \\ \vdots & \vdots & \vdots & \vdots & \vdots & \vdots & \vdots \\ 0 & \dots & \dots & \dots & 0 & -1 & 2p-i(N-1)^2p & 1 \\ 0 & \dots & \dots & \dots & \dots & 0 & -1 & 2p-iN^2p \end{vmatrix} \quad (65)$$

and $F(p) = (-1)^{N+1} \det D(p)$.

Next, in order to express formulae (64) in the original variable ζ , we will apply Heaviside's expansion theorem [19, p.238], i.e.

$$\frac{A(p)}{B(p)} = \frac{A(0)}{B(0)} + \sum_{k=1}^{N+1} \frac{A(\alpha_k)}{\alpha_k B'(\alpha_k)} \exp(\alpha_k \zeta), \quad (66)$$

where $A(p)$ is a polynomial in p of the same or a lower degree than $B(p)$; α_k ($k=1, \dots, N+1$) are the simple zeros of $B(p)$ and $B' = dB/dp$. Hence, (64) can be replaced by

$$\phi_n = 2 \sum_{k=1}^{N+1} \frac{F_{1,n+1}(\alpha_k)}{F'(\alpha_k)} \exp(\alpha_k \zeta) \quad , \quad n = 0, 1, \dots, N-1 ; \quad (67)$$

$$\phi_N = 2 \sum_{k=1}^{N+1} \frac{\exp(\alpha_k \zeta)}{F'(\alpha_k)} .$$

Since from (61), the matrices D and $M-sI$ are similar, one can prove that $\alpha_k = \frac{1}{2}is_k$, where s_k represent the real eigenvalues of M . After some lengthy calculations we obtain the expressions for the intensities of the spectral lines

$$I_0(v) = 1 - 16 \sum_{\substack{j,k=1 \\ j < k}}^{N+1} \frac{F_{11}(\frac{1}{2}is_j) \overline{F_{11}(\frac{1}{2}is_k)}}{F'(\frac{1}{2}is_j) F'(\frac{1}{2}is_k)} \sin^2(s_j - s_k) \frac{v}{4} , \quad (68)$$

$$I_n(v) = -16 \sum_{\substack{j,k=1 \\ j < k}}^{N+1} \frac{F_{1,n+1}(\frac{1}{2}is_j) \overline{F_{1,n+1}(\frac{1}{2}is_k)}}{F'(\frac{1}{2}is_j) F'(\frac{1}{2}is_k)} \sin^2(s_j - s_k) \frac{v}{4} . \quad (69)$$

$n = 1, 2, \dots, N$, with $F_{1,N+1}(\frac{1}{2}is_j) = 1$, and where we have taken into account that the determinants $F_{1,n+1}(\frac{1}{2}is_j)$ and $F(\frac{1}{2}is_j)$ are either real or purely imaginary. In order to simplify the calculations of the determinants it may be advantageous to use the following recursion relations :

$$F_{1j}(p) = (2p - ij^2\rho)F_{1,j+1}(p) + F_{1,j+2}(p) , \quad F_{1,N+1} = 1 , \quad F_{1,N+2} = 0 ;$$

$$F'(p) = 2F_{11}(p) + 2pF'_{11}(p) + 2F'_{12}(p) ; \quad (70)$$

$$F'_{1j}(p) = 2F_{1,j+1}(p) + (2p - ij^2\rho)F'_{1,j+1}(p) + F'_{1,j+2}(p) , \quad j = 1, \dots, N .$$

It is clear, especially regarding (61), that the eigenvalue method (Subsection 2.1) and Heaviside's operational method (Subsection 2.2) are completely equivalent.

At this point it is perhaps worthwhile to comment on the paper by Leroy and Claeys [27] wherein a Laplace transform method is used to integrate the truncated system (45). To begin with the Laplace transform $F(s) = \mathcal{L}[f(z)] = \int_0^\infty f(z)e^{-sz} dz$ imposes the function $f(z)$ to be defined in a domain $[0, \infty[$ for the variable z . However, the functions $\phi_n(\zeta)$, with $\zeta = \pi \epsilon_1 z / \lambda \epsilon_r$, describe the amplitudes of the diffracted light in the finite domain $[0, v]$, where the ultrasonic field is active. So without either changing the variables, extending the domain of the function towards $[0, \infty[$ or introducing a Heaviside unit

function restricting the domain to $[0, L]$, the use of a Laplace transform in the present form is physically inadmissible. To support this case we refer to Jeffrey's comments [19, pp.458,459] on the Laplace transform, where next to physical arguments, mathematical plea in favour of Heaviside's operational method is given. Secondly the calculation of the inverse transforms $\phi_n(\zeta)$ in Leroy and Claeys' paper leads to rather complicated infinite series of Bessel functions, contrary to the finite expressions for the amplitudes obtained by Heaviside's expansion theorem used above.

3. COMPARISON OF THE DIFFERENT APPROXIMATE METHODS WITH EXPERIMENTAL RESULTS

In Fig. 5 ($Q=0.94$), Fig. 6 ($Q=1.26$) and Fig. 7 ($Q=1.48$) we compare curves for I_0 vs v obtained from RN's geometrical theory [48], Mertens' perturbation theory [26,32] and the NOA method (for $N=7$) with the experimental results of Klein and Hiedemann [22]. In Fig. 8 ($Q=0.94$), Fig. 9 ($Q=1.26$) and Fig. 10 ($Q=1.48$) curves for I_1 vs v obtained with the same approximate methods are compared with the experimental points obtained by Klein [20]. It must be remarked that in the experiments of Klein, according to a finite-amplitude distortion of the sound wave an asymmetric diffraction pattern was observed. In all plots of I_1 the average of the measured positive and negative light intensities is shown and in no case the measured intensities differ at most 5 percent. From numerical calculation, it was found that, for the considered values of Q , $\phi_j \approx 0$ for $j \geq 7$; a typical example is shown in Fig. 11 for $Q=0.94$. Hence, we have computed the intensities (56), (57) and (68), (69) up to $N=7$. The theoretical results perfectly coincide since both methods considered are equivalent; not surprisingly concerning CPU time, calculations with Heaviside's operational method are about 25% faster than the ones based on the eigenvalue method. For the three considered values of Q the theoretical curves fit the experimental points for I_0 and I_1 perfectly. As discussed earlier (Subsection 1.1) it is clearly seen from the figures that the deviation from RN's elementary theory is already apparant for rather low values of v . Evidently there is an excellent fitting with the experimental points whereas the perturbation method fails (cf. the discussion in Subsection 1.2).

4. COMPARISON OF THE DIFFERENT APPROXIMATE METHODS TO ONE ANOTHER

In this section the NOA method, with N ranging from 7 to 15, is carried out for selected values of the Klein-Cook parameter Q (between 0.1 and 50) and with the RN parameter v ranging from 0 to 15. The zeroth and first order intensities thus obtained are compared with either the squared Bessel function expressions or with the squared sine expressions obtained from the IOA method (Eqs. (47)).

In Fig. 12 we compare the curves for $I_0(v)$ and $I_1(v)$, computed from (56) and (57) ($n=1$) for $Q=0.1$ and $Q=1$, with the squared Bessel functions $J_0^2(v)$ and $J_1^2(v)$. Remark that for $Q=0.1$, the zeroth and first order intensities perfectly coincide with the corresponding Bessel function expressions. For $Q=5$ and $Q=50$, $I_0(v)$ and $I_1(v)$ are respectively shown in Figs. 13 and 14. For $Q=0.1$ it was necessary to take $N=15$, i.e. a system of 16 coupled equations had to be taken into account. For all other values of Q a value of $N=7$ was sufficient. To test our numerical procedure based on the eigenvalue method we have compared our results with similar ones computed by straightforward numerical integration of the system (45) by a discrete step method [21,24,45]. From Figs. 11 to 13 (and additional figures for stepwise values of Q between 0.01 and 100, not shown here) we may conclude that

- For $Q \ll 1$ (i.e. $Q \approx 0.1$) the intensities I_0 and I_1 calculated with the NOA method coincide practically with squared Bessel functions for the whole range of v considered;
- For $0.1 < Q \approx 2$ the intensities fit the squared Bessel function expressions up to a threshold in the close neighbourhood of $v=2.405$ (the first zero of $J_0(v)$);
- For $2 < Q \approx 10$ the intensities considerably deviate as well from the squared Bessel functions as from the squared sine expressions (for $Q=5$ there is only a good fitting with the latter up to $v \approx 2$);
- For $Q \gg 1$ (i.e. $Q > 10$), up to a certain threshold v_1 ($v_1 \approx 5$ for $Q=50$), practically all the energy of the incident light is concentrated in I_0 so that no diffraction occurs; above that threshold diffraction only excites first orders (Bragg diffraction); the fitting of the NOA curves ($N=7$) with the squared sine curves ($N=1$) is excellent up to $2v_1$ (≈ 10 for $Q=50$).

5. FURTHER NEW RESULTS OBTAINED WITH THE NOA METHOD

As argued in recent work [12,14,53], ρ , v and $Q=\rho v$ are relevant (though dependent) parameters for the investigation of criteria for multi-order RN diffraction or two-order Bragg diffraction. Based on our numerical integration method, outlined above, we present in Fig. 15 a three-dimensional plot of I_0 as function of Q and v (similarly one could use ρ and v). The cross-sections correspond to constant values of Q ranging from 0 to 10 with steps of 0.25. Analogously in Fig. 16 I_1 is plotted as a function of Q and v . In both figures one may clearly observe the evolution from the RN regime ($Q \ll 1$) to the Bragg regime ($Q \gg 1$), passing through all intermediate steps. In Fig. 17 we show curves for constant I_0 in a v, Q -plane. In order to realize a chosen constant value of I_0 , this plot allows the selection of corresponding characteristic couples (v, Q) . Fig. 18 presents an analogous plot for I_1 . In Figs. 19, 20, curves of constant I_0 , respectively I_1 , are depicted in a Q, ρ -plane, from which pairs (Q, ρ) may be obtained. It is apparent in both figures, that the behaviour of the iso-curves drastically changes when passing from the region where $v < 4$ to the one where $v > 4$. In the region above the line $\rho = Q/4$ ($v < 4$) the iso-curves present a rather simple structure, while in the region below the line $\rho = Q/4$ ($v > 4$) they are behaving rather chaotically. A more profound analysis and interpretation of the results will be presented later.

APPENDIX A

General solution of the infinite system (33) for $\rho = 0$ (cf. [51])

For $\rho = 0$ the system (33) simplifies into

$$2\frac{d\phi_n}{d\zeta} - (\phi_{n-1} - \phi_{n+1}) = 0, \quad n = 0, \pm 1, \pm 2, \dots, \quad (A1)$$

with boundary conditions

$$\phi_n(0) = \delta_{n0}. \quad (A2)$$

According to a theorem of Sonine [44], a solution $\phi_n(\zeta)$ of the system (A1) with initial values $\phi_n(0)$, may be developed into a series of Bessel functions

$$\phi_n(\zeta) = \phi_n(0)J_0(\zeta) + \sum_{m=1}^{\infty} [\phi_{n-m}(0) + (-1)^m \phi_{n+m}(0)] J_m(\zeta) \\ n = 0, \pm 1, \pm 2, \dots. \quad (A3)$$

Using (A2) this series becomes

$$\phi_n(\zeta) = J_0(\zeta)\delta_{n0} + \sum_{m=1}^{\infty} [\delta_{n-m,0} + (-1)^m \delta_{n+m,0}] J_m(\zeta), \\ n = 0, \pm 1, \pm 2, \dots, \quad (A4)$$

so that

$$\phi_0(\zeta) = J_0(\zeta), \quad \phi_n(\zeta) = J_n(\zeta) \quad (n > 0), \quad \phi_{-n}(\zeta) = (-1)^n J_n(\zeta) \quad (n > 0). \quad (A5)$$

Recalling the property of the Bessel functions, $J_{-n}(\zeta) = (-1)^n J_n(\zeta)$, the general solution of (A1) satisfying the boundary conditions (A2) may finally be written as

$$\phi_n(\zeta) = J_n(\zeta), \quad n = 0, \pm 1, \pm 2, \dots. \quad (A6)$$

A P P E N D I X B

An example of the use of the eigenvalue problem developed in subsection 2.1

We shall take $N=1$, which will lead to an analytical solution of the problem. The truncated system (45) becomes

$$\begin{aligned} \frac{d\phi_0}{d\zeta} + \phi_1 &= 0 , \\ 2\frac{d\phi_1}{d\zeta} - \phi_0 &= i\rho\phi_1 , \end{aligned} \tag{B1}$$

with boundary conditions

$$\phi_0(0) = 1 \quad , \quad \phi_1(0) = 0 . \tag{B2}$$

As a solution we assume

$$\phi_0 = \sqrt{2} a_0 \exp\left(\frac{1}{2}is\zeta\right) , \tag{B3}$$

$$\phi_1 = a_1 \exp\left(\frac{1}{2}is\zeta\right) . \tag{B4}$$

Upon substitution in Eqs. (B1) the characteristic equation follows

$$\det(\mathbf{M}-s\mathbf{I}) = \begin{vmatrix} -s & i\sqrt{2} \\ -i\sqrt{2} & \rho-s \end{vmatrix} = s^2 - \rho s - 2 = 0 , \tag{B5}$$

where the matrix

$$\mathbf{M} = \begin{pmatrix} 0 & i\sqrt{2} \\ -i\sqrt{2} & \rho \end{pmatrix} \tag{B6}$$

is Hermitian. From (B5) the (real) eigenvalues are easily obtained :

$$s_1 = \frac{1}{2}(\rho + \sqrt{\rho^2+8}) , \tag{B7}$$

$$s_2 = \frac{1}{2}(\rho - \sqrt{\rho^2+8}) . \tag{B8}$$

The equation for the eigenvalues is

$$(M - s_k \mathbf{I}) \cdot \mathbf{a}^{(k)} = \mathbf{0} . \quad (\text{B9})$$

For $k=1$ we thus obtain

$$\begin{aligned} -s_1 a_0^{(1)} + i\sqrt{2} a_1^{(1)} &= 0 , \\ -i\sqrt{2} a_0^{(1)} + (\rho - s_1) a_1^{(1)} &= 0 , \end{aligned} \quad (\text{B10})$$

where the second equation is in fact redundant. A solution may be chosen as

$$\begin{aligned} a_0^{(1)} &= \frac{\sqrt{2}}{2} , \\ a_1^{(1)} &= -\frac{i}{2} s_1 . \end{aligned} \quad (\text{B11})$$

Similarly, we find for $k=2$

$$\begin{aligned} a_0^{(2)} &= \frac{\sqrt{2}}{2} , \\ a_1^{(2)} &= -\frac{i}{2} s_2 . \end{aligned} \quad (\text{B12})$$

Hence, the amplitudes can be written as (cf. Eqs. (53) and (54))

$$\phi_0 = c_1 \exp\left(\frac{1}{2} i s_1 \zeta\right) + c_2 \exp\left(\frac{1}{2} i s_2 \zeta\right) , \quad (\text{B13})$$

$$\phi_1 = c_1 a_1^{(1)} \exp\left(\frac{1}{2} i s_1 \zeta\right) + c_2 a_1^{(2)} \exp\left(\frac{1}{2} i s_2 \zeta\right) . \quad (\text{B14})$$

The constants are determined by the boundary conditions (B2), hence,

$$\begin{aligned} c_1 + c_2 &= 1 , \\ c_1 a_1^{(1)} + c_2 a_1^{(2)} &= 0 . \end{aligned} \quad (\text{B15})$$

Taking into account (B11) and (B12) we obtain

$$c_1 = -\frac{s_2}{s_1 - s_2} , \quad c_2 = \frac{s_1}{s_1 - s_2} . \quad (\text{B16})$$

Calculating the intensities from the amplitudes (B13) and (B14), therefore using the values of the constants c_1 and c_2 , we find

$$I_0 = \phi_0 \bar{\phi}_0 = 1 + \frac{4s_1 s_2}{(s_1 - s_2)^2} \sin^2 \frac{1}{4}(s_1 - s_2)\zeta, \quad (\text{B17})$$

$$I_{\pm 1} = \phi_{\pm 1} \bar{\phi}_{\pm 1} = \left(\frac{s_1 s_2}{s_1 - s_2}\right)^2 \sin^2 \frac{1}{4}(s_1 - s_2)\zeta. \quad (\text{B18})$$

Finally, introducing the explicit expressions for the eigenvalues (Eqs. (B7) and (B8)) we recover Nagendra Nath's classical results

$$I_0 = 1 - \frac{8}{\rho^2 + 8} \sin^2 \frac{1}{4}\sqrt{\rho^2 + 8} \zeta, \quad (\text{B19})$$

$$I_{+1} = I_{-1} = \frac{4}{\rho^2 + 8} \sin^2 \frac{1}{4}\sqrt{\rho^2 + 8} \zeta. \quad (\text{B20})$$

LIST OF CAPTIONS FOR FIGURES

- Fig. 1. Geometry of AO diffraction
- Fig. 2a. Diffraction spectra at $\varphi=0$ and $\varphi\neq 0$
- Fig. 2b. Diffraction spectrum in p-xylene ($\varphi=0$) (Parthasarathy [46])
- Fig. 3a. Multi-order Raman-Nath diffraction
- Fig. 3b. Single-order Bragg diffraction
- Fig. 4. Geometry of Bragg diffraction
- Fig. 5. Zeroth-order intensity versus RN parameter for $Q=0.94$
- Fig. 6. Zeroth-order intensity versus RN parameter for $Q=1.26$
- Fig. 7. Zeroth-order intensity versus RN parameter for $Q=1.48$
- Fig. 8. First-order intensity versus RN parameter for $Q=0.94$
- Fig. 9. First-order intensity versus RN parameter for $Q=1.26$
- Fig. 10. First-order intensity versus RN parameter for $Q=1.48$
- Fig. 11. Intensities versus RN parameter calculated with the NOA method for $Q=0.94$, with $N=7$
- Fig. 12. Zeroth and first-order intensities versus RN parameter calculated with NOA method for $Q=0.1$ (dotted lines) and $Q=1$ (full lines); the elementary RN approximations $J_0^2(v)$ and $J_1^2(v)$ match exactly the calculated intensities for $Q=0.1$
- Fig. 13. Calculated (full lines) and approximate (dotted lines, corresponding to Eq. (47)) zeroth and first order intensities for $Q=5$
- Fig. 14. Calculated (full lines) and approximate (dotted lines, corresponding to Eq. (47)) zeroth and first order intensities for $Q=50$
- Fig. 15. Three-dimensional plot of I_0 vs. Q and v
- Fig. 16. Three-dimensional plot of I_1 vs. Q and v
- Fig. 17. Curves for constant I_0 in the v, Q -plane
- Fig. 18. Curves for constant I_1 in the v, Q -plane
- Fig. 19. Curves for constant I_0 in the Q, ρ -plane
- Fig. 20. Curves for constant I_1 in the Q, ρ -plane

S A M E N V A T T I N G

De bedoeling van onderhavige studie is een overzicht te geven van klassieke en meer recente benaderde methoden in het akoesto-optisch diffractievraagstuk en hun numerieke resultaten te vergelijken met de experimentele gegevens van Klein en Hiedemann.

In de inleiding wordt de diffractie van licht door ultrageluiden beknopt beschreven en wordt aangetoond, dat de golfvergelijking van het licht, dat zich voortplant in een vloeibaar medium door een ultrageluidsgolf gestoord, aanleiding geeft tot een oneindig stelsel differo-differentiaalvergelijkingen voor de amplituden van de gediffracteerde lichtgolven; dit stelsel is het zg. Raman-Nath (RN) stelsel, waarvan de n^e vergelijking ($n=0, \pm 1, \pm 2, \dots$) het verband geeft tussen de amplituden van de orden $n-1$, n en $n+1$; deze amplituden voldoen aan eenvoudige randvoorwaarden. Drie parameters spelen hierbij een belangrijke rol: (1) de zg. Raman-Nath parameter $v = \pi \epsilon_1 L / \epsilon_r \lambda$; (2) de regime-parameter $\rho = 2\epsilon_r \lambda^2 / \epsilon_1 \lambda^{*2}$; (3) de zg. Klein-Cook parameter $Q = \rho v = 2\pi \lambda L / \lambda^{*2}$. Terwijl de eerste twee afhankelijk zijn van ϵ_1 , die een maat is voor de sterkte van de ultrageluidsgolf, is de derde parameter daarvan onafhankelijk. In een eerste paragraaf wordt een overzicht gegeven van drie benaderde methoden voor de behandeling van het Raman-Nath stelsel.

(1) $\rho = 0$, hetgeen benaderd verwezenlijkt wordt voor grote golflengten van de ultrageluiden. In dit geval kan het oneindig RN stelsel exakt worden opgelost, hetgeen leidt tot dezelfde resultaten als deze bekomen met de elementaire geometrisch optische theorie van Raman en Nagendra Nath. De intensiteiten van de verschillende diffractielijnen worden in dit geval gegeven door de eenvoudige uitdrukkingen $I_n = J_n^2(v)$, waarbij $J_n(v)$ de Besselfunctie van orde n voorstelt. Deze benaderde theorie wordt door Klein en Hiedemann met hun experimentele resultaten vergeleken. Ze blijkt aanvaardbaar voor $v \lesssim 2$ als $Q=0.94$, $v \lesssim 1.5$ als $Q=1.26$ en $v \lesssim 1.3$ als $Q=1.48$.

(2) Een verbetering van deze elementaire RN theorie wordt bekomen door de storingstheorie, die vooreerst door Mertens werd opgesteld, waarbij de amplitude van iedere gediffracteerde golf als een reeksontwikkeling naar ρ (of naar Q) wordt voorgesteld, en waarvan de eerste term $J_n(v)$ is. Vergeleken met de experimenten van Klein en Hiedemann betekent ze een verbetering t.o.v. de elementaire RN theorie. De overeenstemming tussen theorie en experiment is echter niet bevredigend voor $v > 6.5$ als $Q=0.94$, $v > 4.5$ als $Q=1.26$ en $v > 3.5$ als $Q=1.48$.

(3) De NOA methode (N^e orde approximatie). Deze methode bestaat er in het RN stelsel te benaderen door de gediffracteerde orden hoger dan de N^e te

verwaarlozen, zodat het gesymmetriseerde RN stelsel nog maar $N+1$ vergelijkingen bevat. Deze methode werd voor het eerst in 1939 door Nagendra Nath voor $N=1$ opgesteld en later door Mertens tot willekeurige waarden van N uitgebreid.

De tweede paragraaf behandelt de oplossing van dit eindige (afgebroken) stelsel differentiaalvergelijkingen met gegeven randvoorwaarden. Twee methoden worden gebezigd : (1) een eigenwaardenmethode die leidt tot een karakteristieke vergelijking van de graad $N+1$ met reële wortels (eigenwaarden); de intensiteiten worden dan uitgedrukt als een eindige som van kwadraten van sinussen, die functie zijn van v en van de verschillen van de eigenwaarden twee aan twee; de coëfficiënten zijn afhankelijk van de componenten van de eigenvectoren; (2) de operationele methode van Heaviside-Jeffreys, die de amplituden van de gediffracteerde golven uitdrukt in functie van determinanten.

Beide methoden, die trouwens gelijkwaardig zijn, zijn uitstekend geschikt voor de behandeling van het akoesto-optisch vraagstuk met behulp van een computer. De vergelijking van de NOA methode met de experimentele gegevens van Klein en Hiedemann maakt het onderwerp uit van de derde paragraaf. Uit de computerberekeningen blijkt dat voor de beschouwde waarden van Q (0.94, 1.26, 1.48), $N=7$ een uitstekende benadering geeft, die bovendien buitengewoon goed bij de experimentele punten aansluit.

In paragraaf 4 worden de verschillende behandelde benaderingsmethoden systematisch met elkaar vergeleken voor $Q=0.1, 1, 5$ en 50 .

In een laatste paragraaf tenslotte worden nog enkele nieuwe resultaten aangehaald, bekomen door middel van de NOA methode, nl.,

- de oppervlakken van I_0 en I_1 als een functie van Q en v ;
- de isokrommen voor I_0 en I_1 in een v, Q -diagram;
- de isokrommen voor I_0 en I_1 in een Q, ρ -diagram.

Grondige interpretatie van deze resultaten en het eventueel verband met een keuze van ρ of Q voor het bepalen van het diffractieregime zal nader worden onderzocht.

R E F E R E N C E S

- [1] ABRAMOWITZ M. and STEGUN I.A., *Handbook of Mathematical Functions with Formulas, Graphs and Mathematical Tables*, Dover, New York, 1968
- [2] ARSCCTT F.M., *Periodic Differential Equations*, Pergamon Press, Oxford, 1964
- [3] BENLARBI B. and SOLYMAR L., *An Analysis of Volume Plane Gratings at Higher Bragg Angle Incidence*, in : "Int. J. Electron.", 48, 1980, p.361-368
- [4] BLOMME E. and LEROY O., *Diffraction of Light by Ultrasound : Closed Analytical Expression for the Spectra up to Order 2*, in : "J. Acoust. Soc. India", 11, 1983, p.1-6
- [5] BLOMME E. and LEROY O., *Diffraction of Light by Ultrasound : Finite Analytical Expressions for the Spectra up to Order 3*, in : "Acustica", 57, 1985, p.168-174
- [6] BOSCO P., GALLARDO J. and DATTOLI G., *Analysis of the Spherical Raman-Nath Equation*, in : "J. Phys. A : Math. Gen.", 17, 1984, p.2739-2742
- [7] COMPUTATION LABORATORY OF THE NATIONAL APPLIED MATHEMATICS LABORATORIES, NATIONAL BUREAU OF STANDARDS, *Tables Relating to Mathieu Functions*, Columbia University Press, New York, 1951
- [8] DAMON R.W., MALONEY W.T. and McMAHON D.H., *Interaction of Light with Ultrasound : Phenomena and Applications*, in : "Physical Acoustics. Principles and Methods. Vol. 7", Mason W.P. and Thurston R.N. (eds.), Academic Press, New York, 1970, p.273-366
- [9] DATTOLI G., RICETTA M. and PINTO I., *Recursive Differential Equations of the Raman-Nath Type : A General Review*, in : "Nuovo Cimento", 4D, 1984, p.293-311
- [10] EXTERMANN R. et WANNIER G., *Théorie Mathématique de la Diffraction de la Lumière par les Ultrasons*, in : "Helv. Phys. Acta", 9, 1936, p.520-532
- [11] FRANKLIN J.N., *Matrix Theory*, Prentice-Hall Corp., New Jersey, 1968
- [12] GAYLORD T.K. and MOHARAM M.G., *Thin and Thick Gratings : Terminology Clarification*, in : "Appl. Opt.", 20, 1981, p.3271-3273
- [13] GILL S.P., *The Diffraction of Light by Sound*, Technical Memorandum 58, Acoustic Research Laboratory, Harvard University, Cambridge, MA, 1964
- [14] HARIHARAN P., *Optical Holography, Principles, Techniques and Applications*, Cambridge University Press, Cambridge, UK, 1984
- [15] HEREMAN W., *Theoretische Aspecten van Akoesto-Optische Diffractie* (unpublished Ph.D. Thesis), Gent, 1982
- [16] HEREMAN W., *Een Bijdrage tot de Theoretische Studie van de Diffractie van Gewoon en Laserlicht door een Ultrageluidsgolf in een Vloeistof* (unpublished study submitted for a prize contest of the Royal Academy of Sciences, Literature and Fine Arts of Belgium), Gent, 1984

- [17] HEREMAN W., *Contribution to the Theoretical Study of the Diffraction of Ordinary and Laser Light by an Ultrasonic Wave in a Liquid*, in "Academia Analecta, Klasse der Wetensch.", 48, 1986, p.23-52
- [18] JÄÄSKELAINEN T., *Analysis of Four Wave Diffraction of Thick Transmission Gratings*, in : "Lett. Nuovo Cimento", 26, 1979, p.439-444
- [19] JEFFREYS H. and SWIRLES JEFFREYS B., *Methods of Mathematical Physics*, Cambridge University Press, Cambridge. Second Edition, 1950
- [20] KLEIN W.R., *An Investigation of Light Diffracted by Wide, High-Frequency Ultrasonic Beams* (unpublished M.S. Thesis), East Lansing, 1962
- [21] KLEIN W.R. and COOK B.D., *Unified Approach to Ultrasonic Light Diffraction*, in : "IEEE Trans. Son. Ultrason," SU-14, 1967, p.123-134
- [22] KLEIN W.R. and HIEDEMANN E.A., *An Investigation of Light Diffracted by Wide, High-Frequency Ultrasonic Beams*, in : "Physica", 29, 1963, p.981-986
- [23] KORPEL A., *Acousto-Optics*, in : "Applied Solid State Science. Vol. 3", R. Wolfe (ed.), Academic Press, New York, 1972, p.71-180
- [24] KORPEL A., Private Communication
- [25] KORPEL A., *Acousto-Optics*, Marcel Dekker, New York, 1988
- [26] KULIASKO F., MERTENS R. and LEROY O., *Diffracton of Light by Supersonic Waves. The Solution of the Raman-Nath Equations I*, in "Proc. Indian Acad. Sci.", 68A, 1968, p.295-302
- [27] LEROY O. and CLAEYS J.-M., *Light Diffraction by One Ultrasonic Wave : Laplace Transform Method*, in : "Wave Motion", 6, 1984, p.33-39
- [28] LEWIS J.W. and SOLYMAR L., *A Generalized Coupled Wave Theory of Volume Diffraction in Two Dimensions*, in : "Proc. Roy. Soc.", 398A, 1985, p.45-80
- [29] MAGNUSSON R. and GAYLORD T.K., *Diffraction Efficiencies of Thin Phase Gratings with Arbitrary Grating Shape*, in : "J. Opt. Soc. Am.", 68, 1978, p.806-809
- [30] MAGNUSSON R. and GAYLORD T.K., *Diffraction Regimes of Transmission Gratings*, in : "J. Opt. Soc. Am.", 68, 1978, p.809-814
- [31] MEIXNER J. und SCHÄFKE F.W., *Mathieusche Funktionen und Sphäroidfunktionen*, Springer-Verlag, Berlin, 1954
- [32] MERTENS R., *Diffraction of Light by Progressive Supersonic Waves*, in : "Med. Kon. VI. Acad. Wet.", 1950, Nr 12, p.1-37
- [33] MERTENS R., *Diffraction of Light by Two Parallel Superposed Supersonic Waves, One Being the n-th Harmonic of the Other : A Critical Study of the Methods Leading to Approximate Solutions in Finite Form*, in : "Proc. Indian Acad. Sci.", 55, 1962, p.63-98
- [34] MERTENS R. und HEREMAN W., *Über die Raman-Nathsche Theorie der Beugung des Lichtes an Ultraschallwellen*, in : "Fortschritte der Akustik" (DAGA'80, München). VDE-Verlag, Berlin, 1980, p.563-566

- [35] MERTENS R., HEREMAN W. and VERHEEST F., *Some Recent Developments in the Theory of Diffraction of Light by Ultrasonic Waves*, in : "Conf. Proc. 1st Spring School on Acousto-Optics and Applications", Gdansk, Poland, 1980, p.33-51
- [36] MERTENS R. and HEREMAN W., *Diffraction of Light by Ultrasonic Waves in the Case of Oblique Incidence of the Light. General Theory and Approximations*, in : "Proc. Second Spring School on Acousto-Optics and Applications", Gdansk, Poland, 1983, p.9-31
- [37] MERTENS R. and KULIASKO F., *Diffraction of Light by Supersonic Waves : The Solution of the Raman-Nath Equations. II. The Exact Solution*, in : "Proc. Indian Acad. Sci.", 68A, 1968, p.303-311
- [38] MERTENS R. and LEROY O., *On the Symmetry of the Diffraction Pattern Obtained by the Diffraction of Light by Ultrasonic Waves*, in : "Acustica", 28, 1973, p.182-185
- [39] MILLER R.B. and HIEDEMANN E.A., *Study of the Intensity Distribution of the Light Diffracted by Ultrasonic Waves*, in : "J. Acoust. Soc. Am.", 11, 1958, p.1042-1046
- [40] MOHARAM M.G., GAYLORD T.K. and MAGNUSSON R., *Criteria for Bragg Regime Diffraction by Phase Gratings*, in : "Opt. Comm.", 32, 1980, p.14-18
- [41] MOHARAM M.G., GAYLORD T.K. and MAGNUSSON R., *Criteria for Raman-Nath Regime Diffraction by Phase Gratings*, in : "Opt. Comm.", 32, 1980, p.19-23
- [42] NAGENDRA NATH N.S., *The Diffraction of Light by High Frequency Sound Waves : Generalised Theory. The Asymmetry of the Diffraction Phenomena at Oblique Incidence*, in : "Proc. Indian Acad. Sci.", 4A, 1936, p.222-242
- [43] NAGENDRA NATH N.S., *The Diffraction of Light by Supersonic Waves*, in : "Proc. Indian Acad. Sci.", 8A, 1938, p.499-503
- [44] NIELSSEN N., *Handbuch der Theorie der Cylinderfunktionen*, B.G. Teubner, Leipzig, 1904
- [45] OTTOY J.-P., Fortran 77 Program Based on Runge-Kutta Method on AD-10 Computer
- [46] PARTHASARATHY S., *Diffraction of Light by Ultrasonic Waves*, in : "Proc. Indian Acad. Sci.", 3A, 1936, p.442-447
- [47] PIEPER R., KORPEL A. and HEREMAN W., *Extention of the Acousto-Optic Bragg Regime through Hamming Apodization of the Sound Field*, in : "J. Opt. Soc. Am. A", 3, 1986, p.1608-1619
- [48] RAMAN C.V. and NAGENDRA NATH N.S., *The Diffraction of Light by High Frequency Sound Waves, Part I*, in : "Proc. Indian Acad. Sci.", 2A, 1935, p.406-412
- [49] RAMAN C.V. and NAGENDRA NATH N.S., *The Diffraction of Light by High Frequency Sound Waves, Part II*, in : "Proc. Indian Acad. Sci.", 2A, 1935, p.413-420

- [50] RAMAN C.V. and NAGENDRA NATH N.S., *The Diffraction of Light by High Frequency Sound Waves, Part III : Doppler Effect and Coherence Phenomena*, in : "Proc. Indian Acad. Sci.", 3A, 1936, p.75-84
- [51] RAMAN C.V. and NAGENDRA NATH N.S., *The Diffraction of Light by High Frequency Sound Waves, Part IV : Generalised Theory*, in : "Proc. Indian Acad. Sci.", 3A, 1936, p.119-125
- [52] RAMAN C.V. and NAGENDRA NATH N.S., *The Diffraction of Light by High Frequency Sound Waves, Part V : General Considerations. Oblique Incidence and Amplitude Changes*, in : "Proc. Indian Acad. Sci.", 3A, 1936, p.459-465
- [53] SOLYMAR L. and COOKE D.J., *Volume Holography and Volume Gratings*, Academic Press, New York, 1981
- [54] WATSON G.N., *A Treatise on the Theory of Bessel Functions*, Cambridge University Press, Cambridge, 1966, 2nd Edition

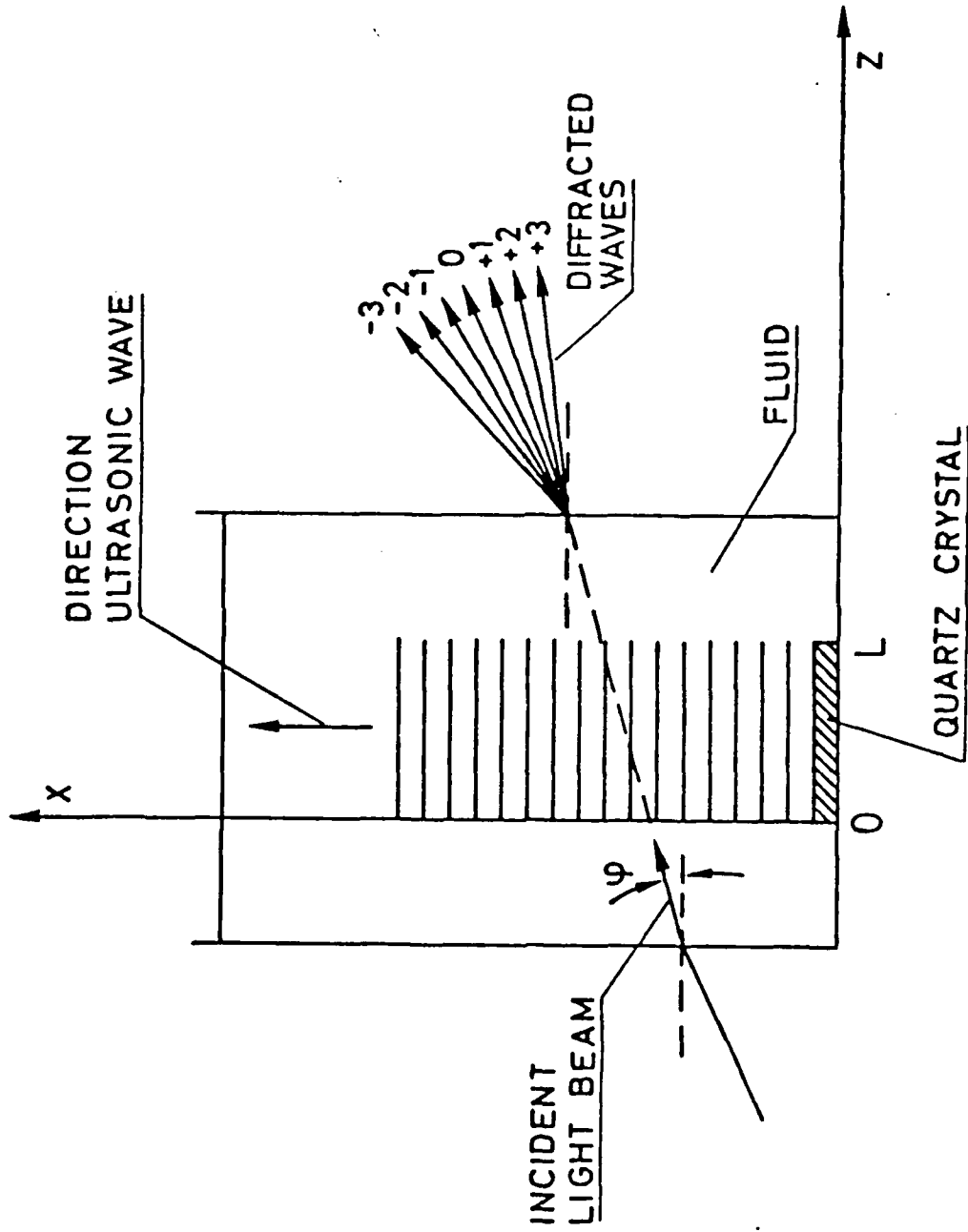


Figure 1

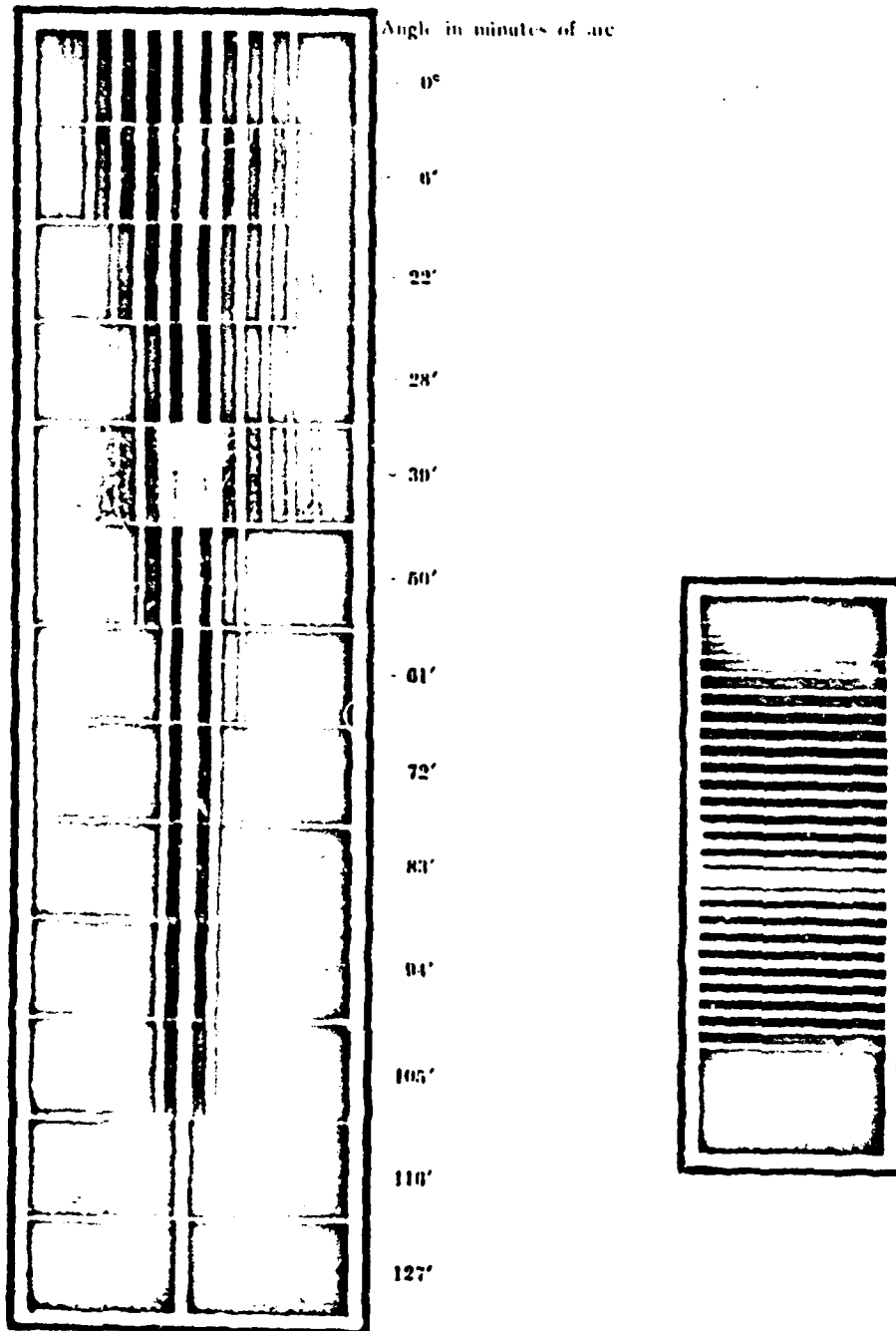


Figure 2

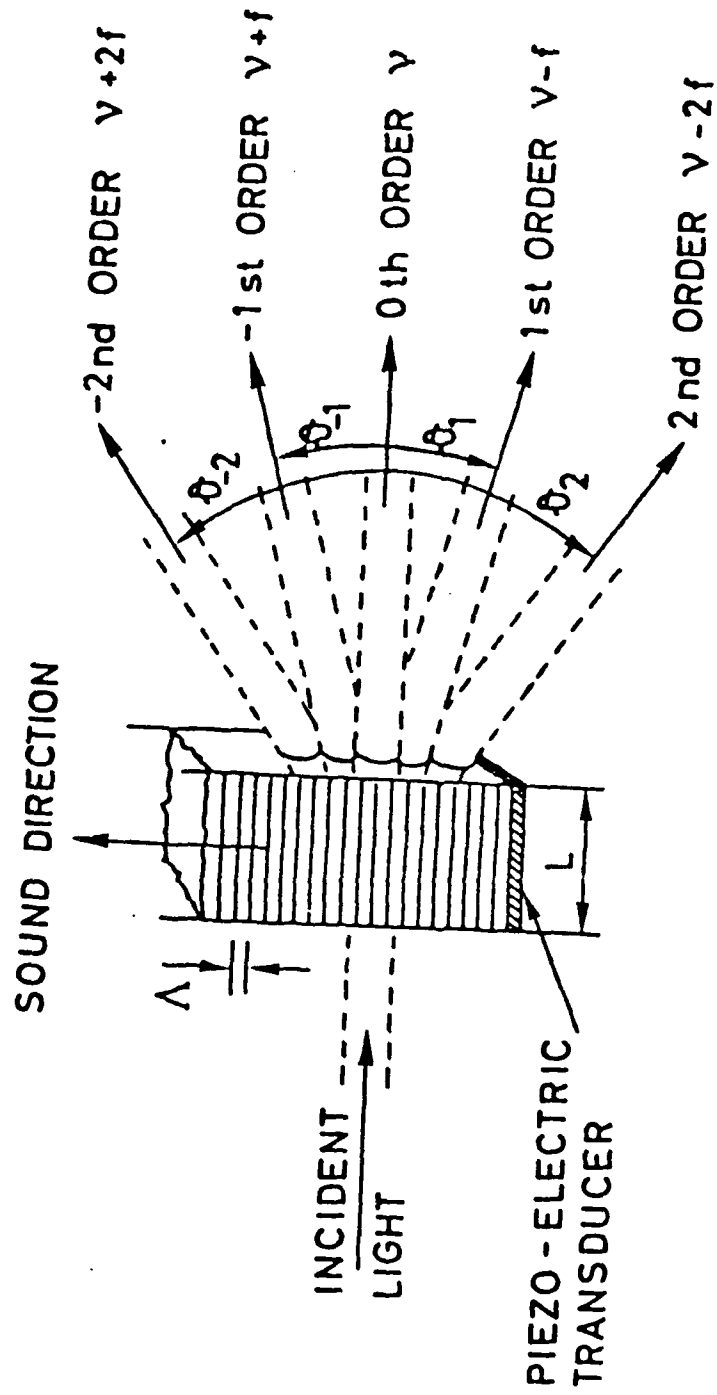


Figure 3a

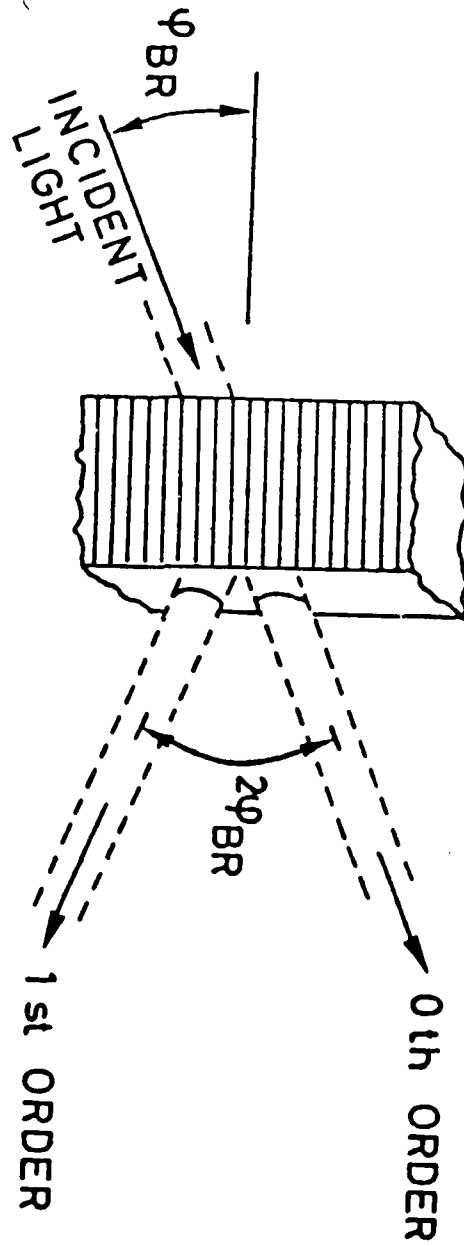


Figure 3b

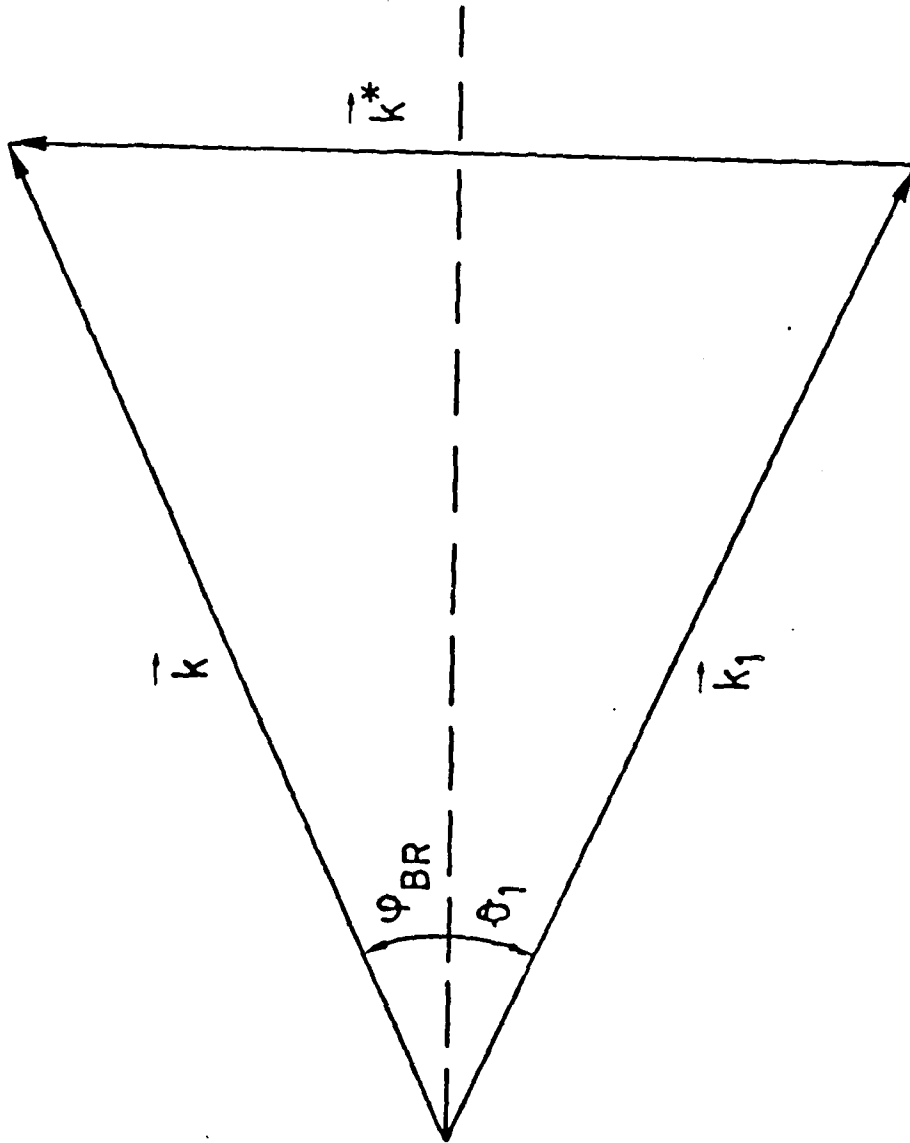


Figure 4

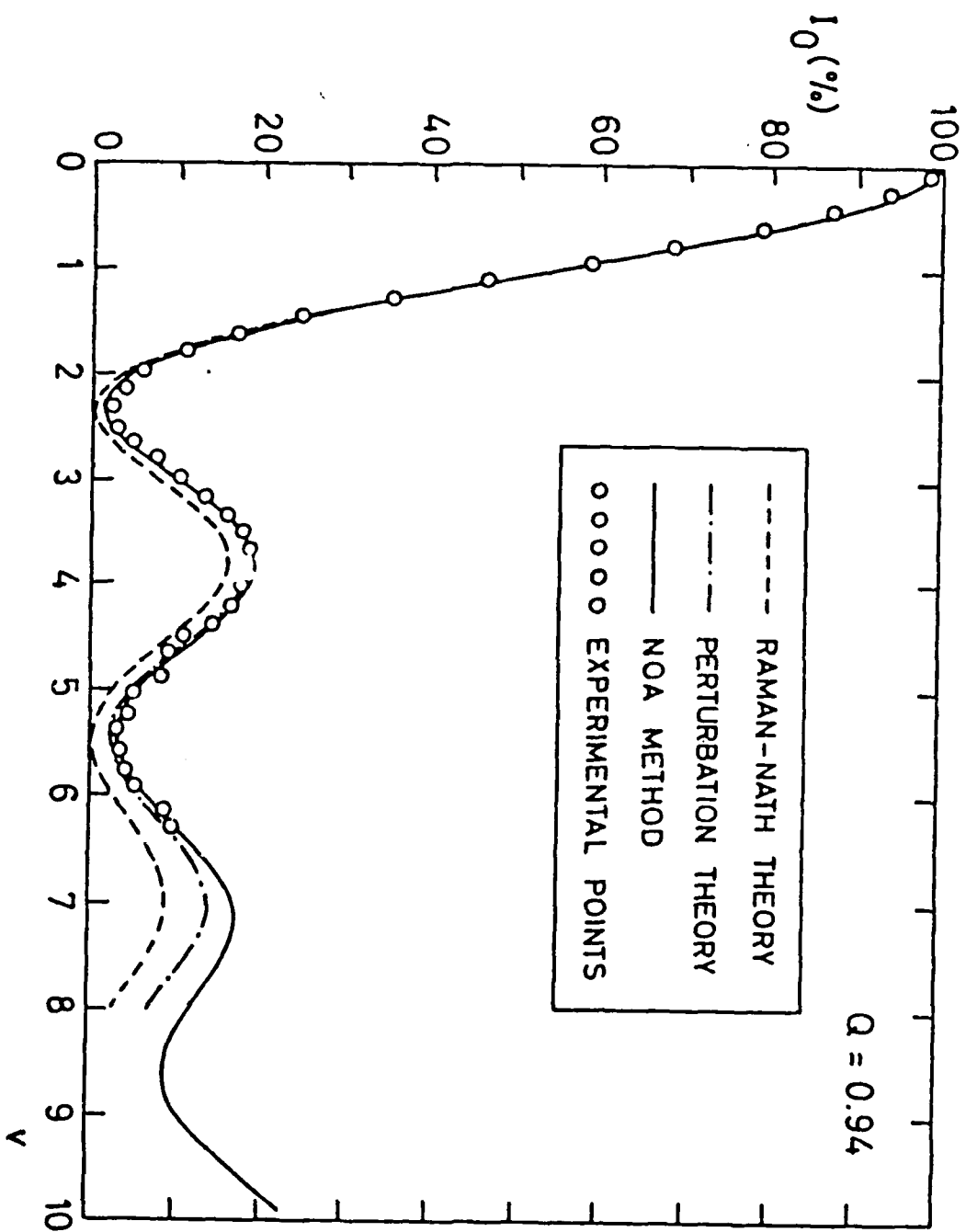


Figure 5

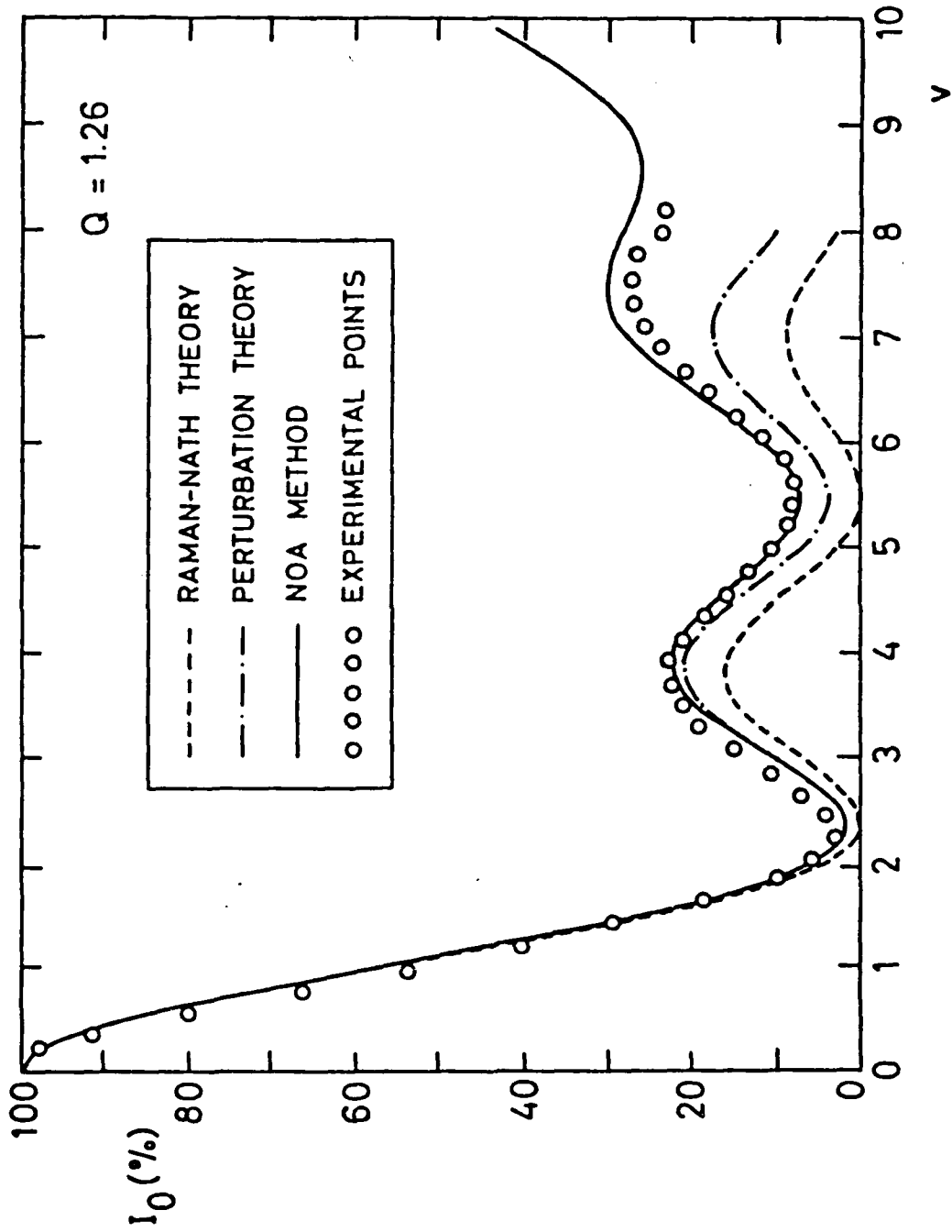


Figure 6

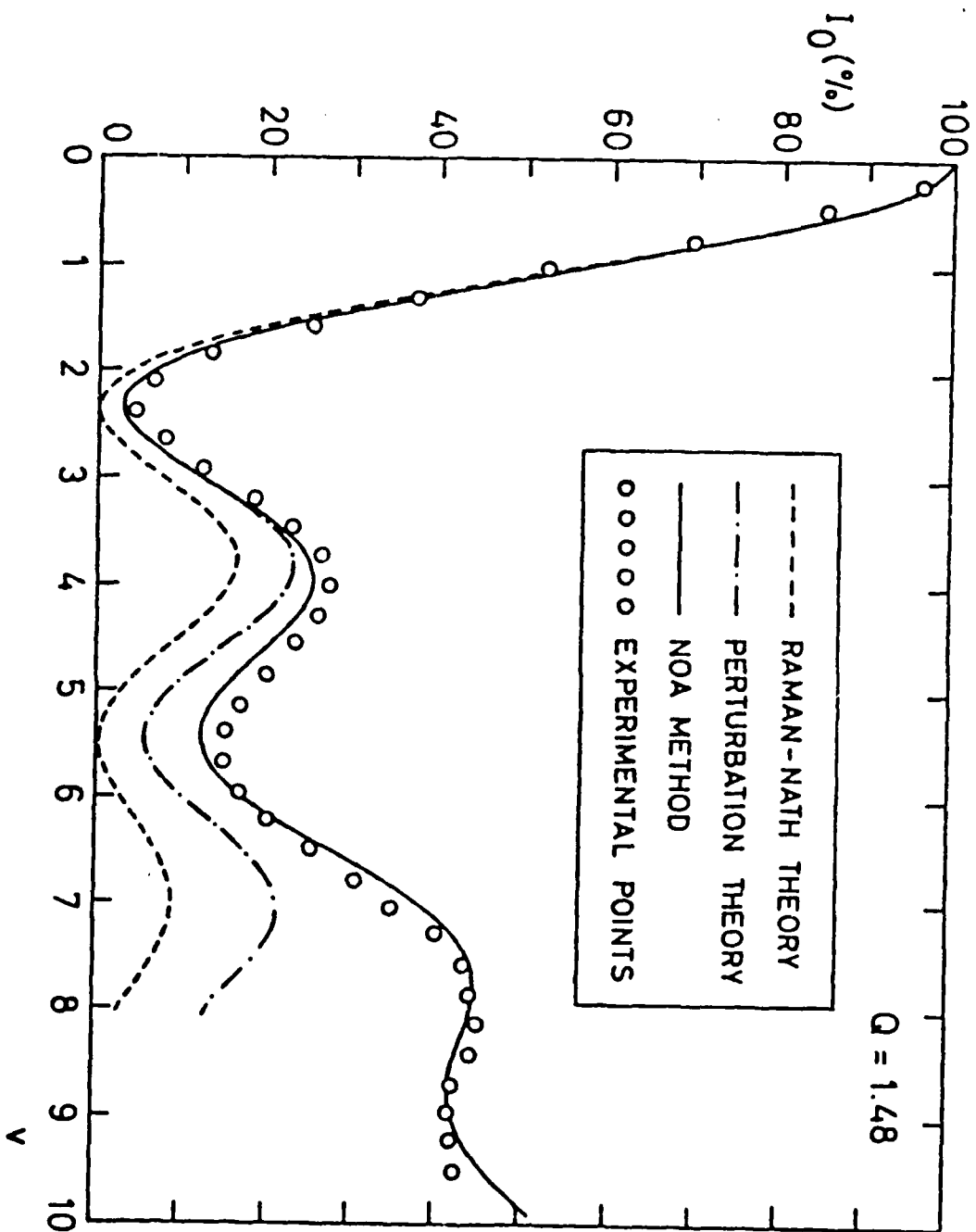


Figure 7

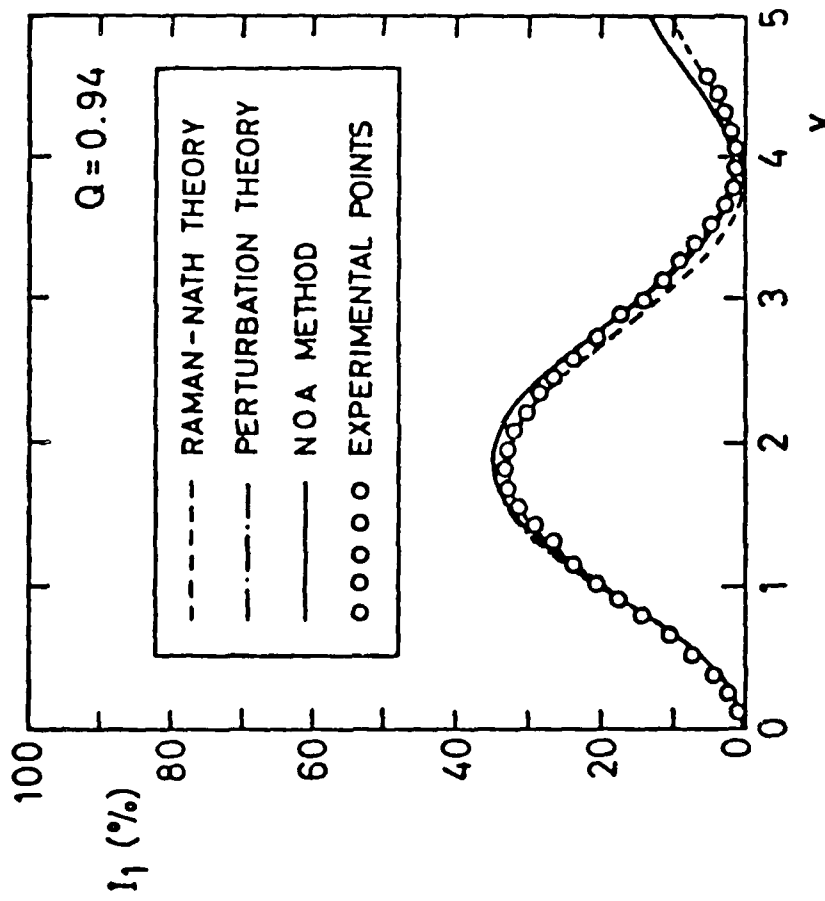


Figure 8

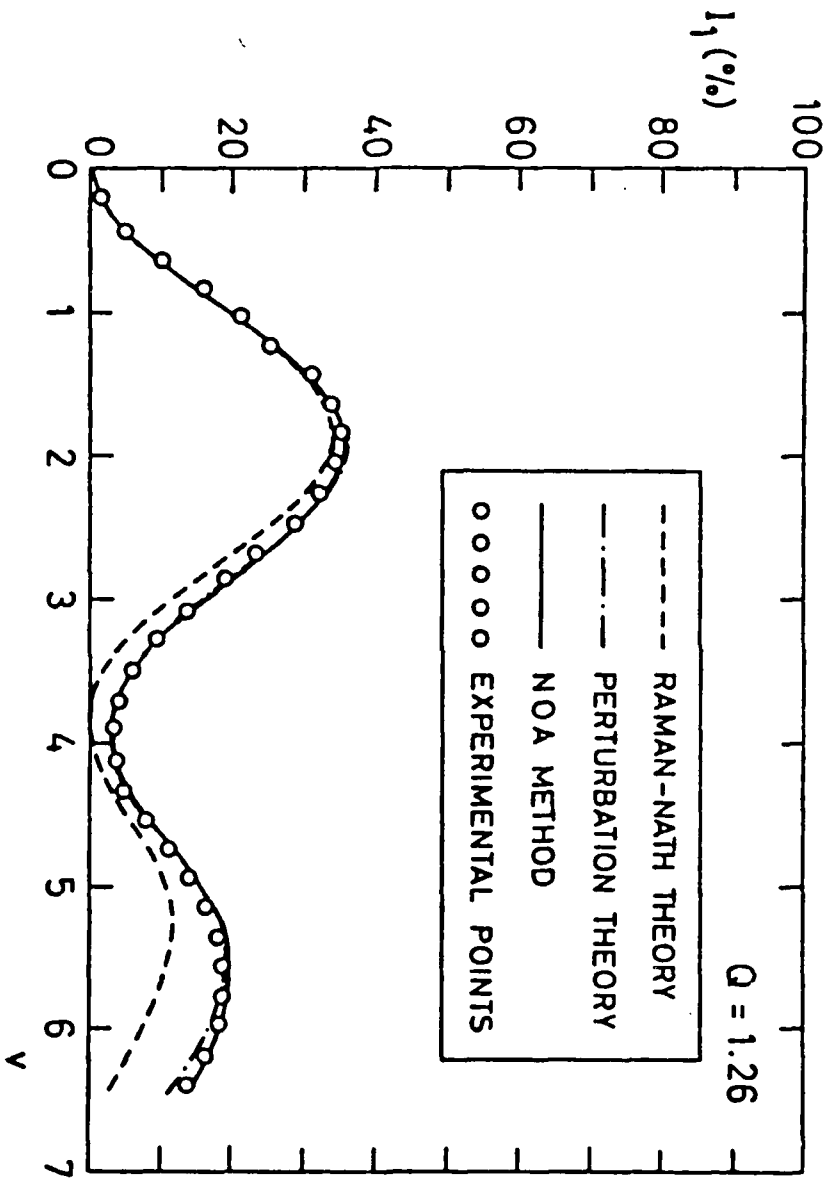


Figure 9

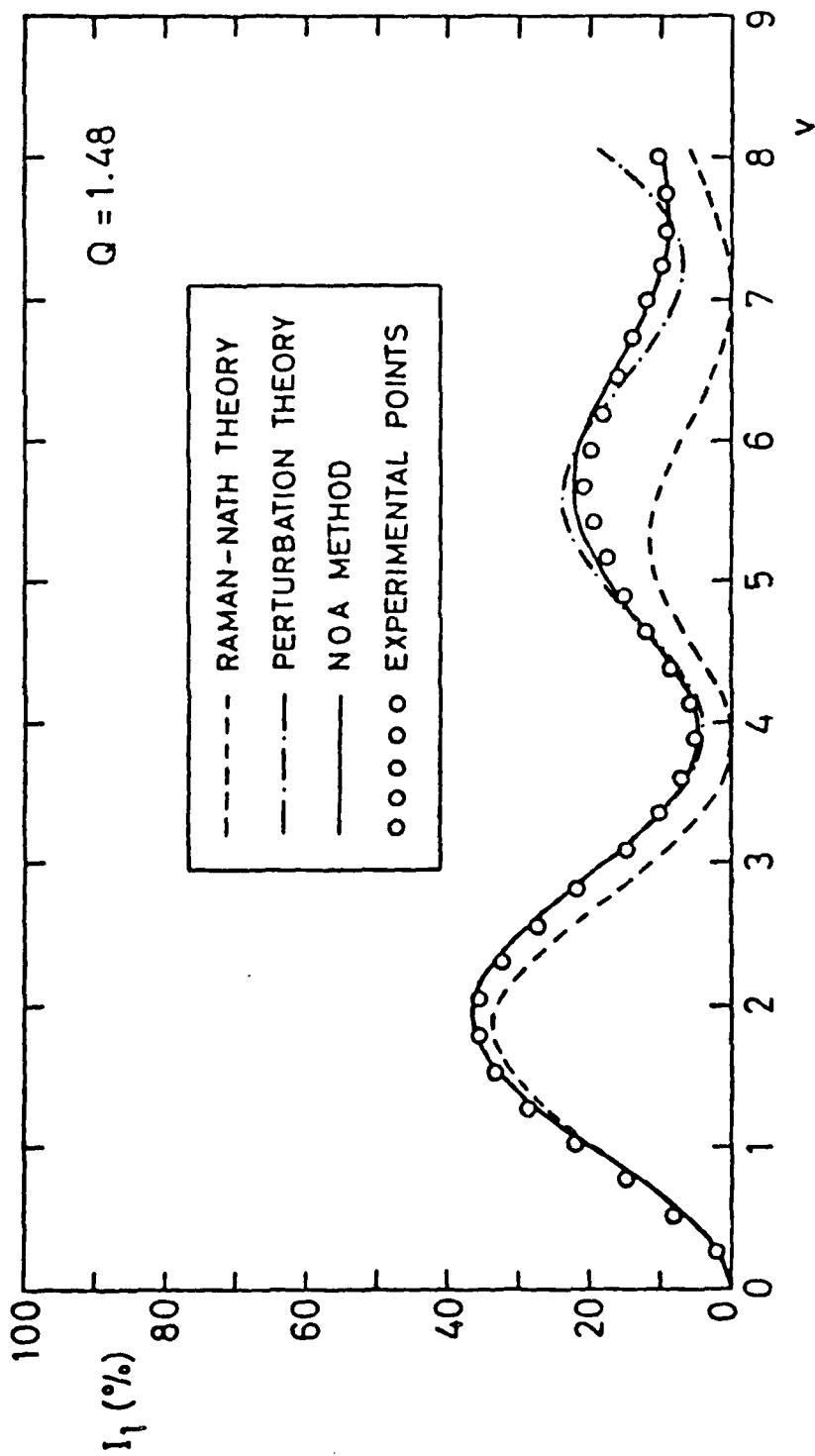


Figure 10

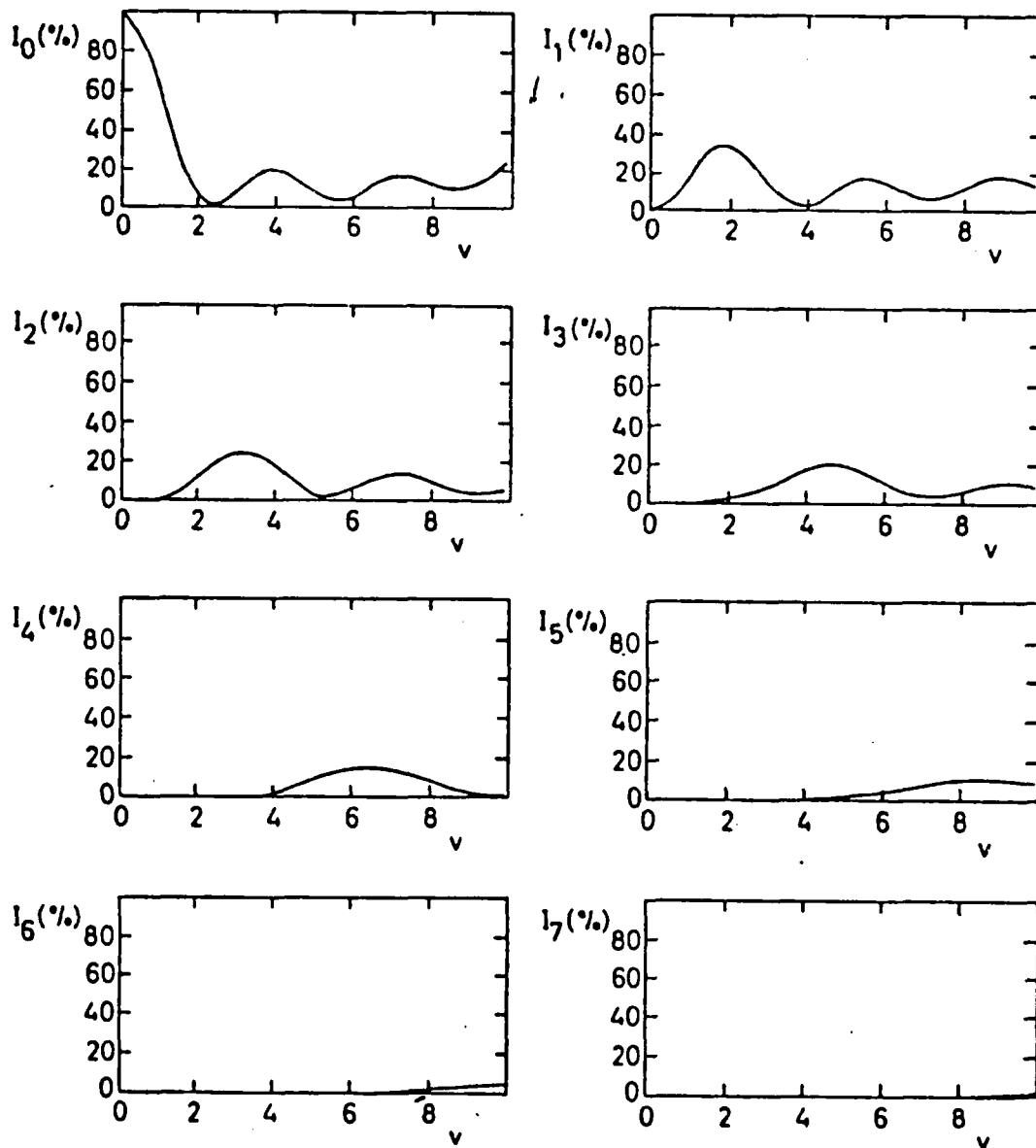
NOA METHOD $Q = 0.94$

Figure 11

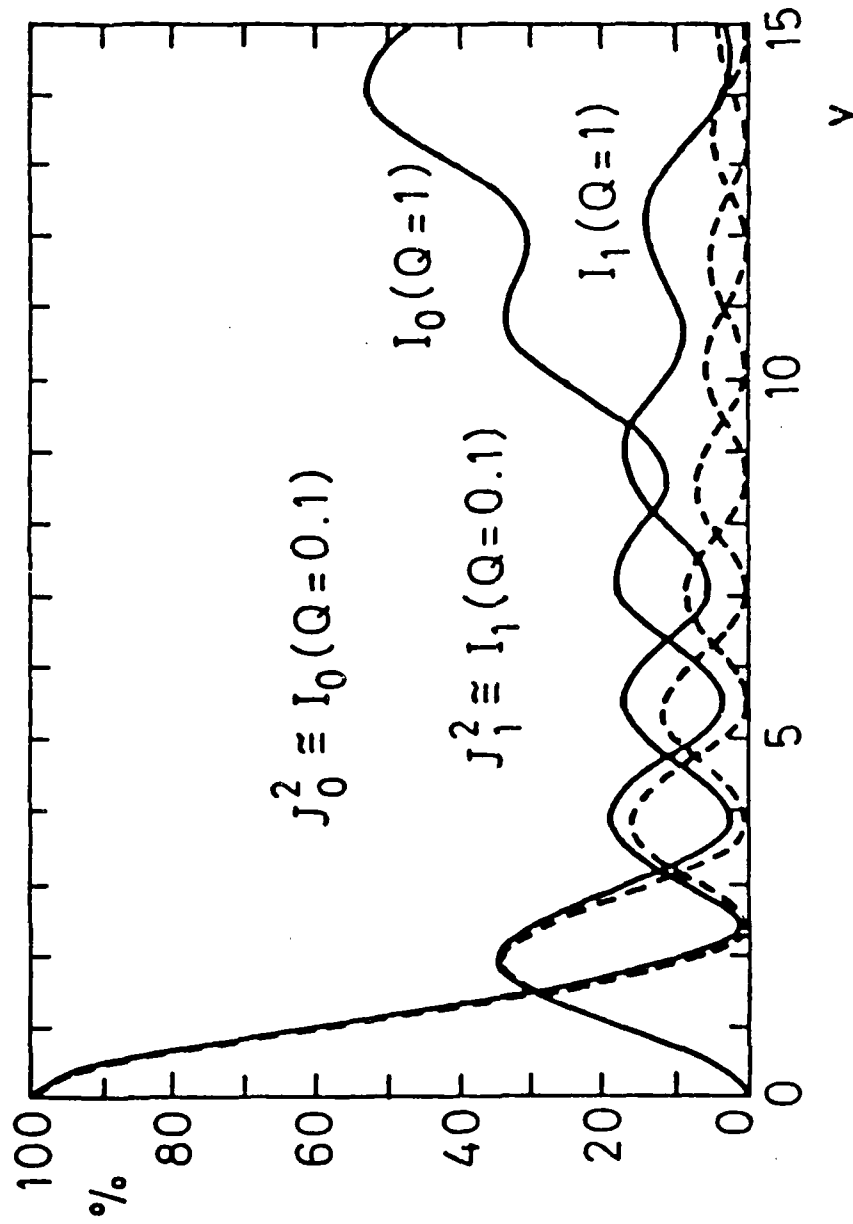


Figure 12

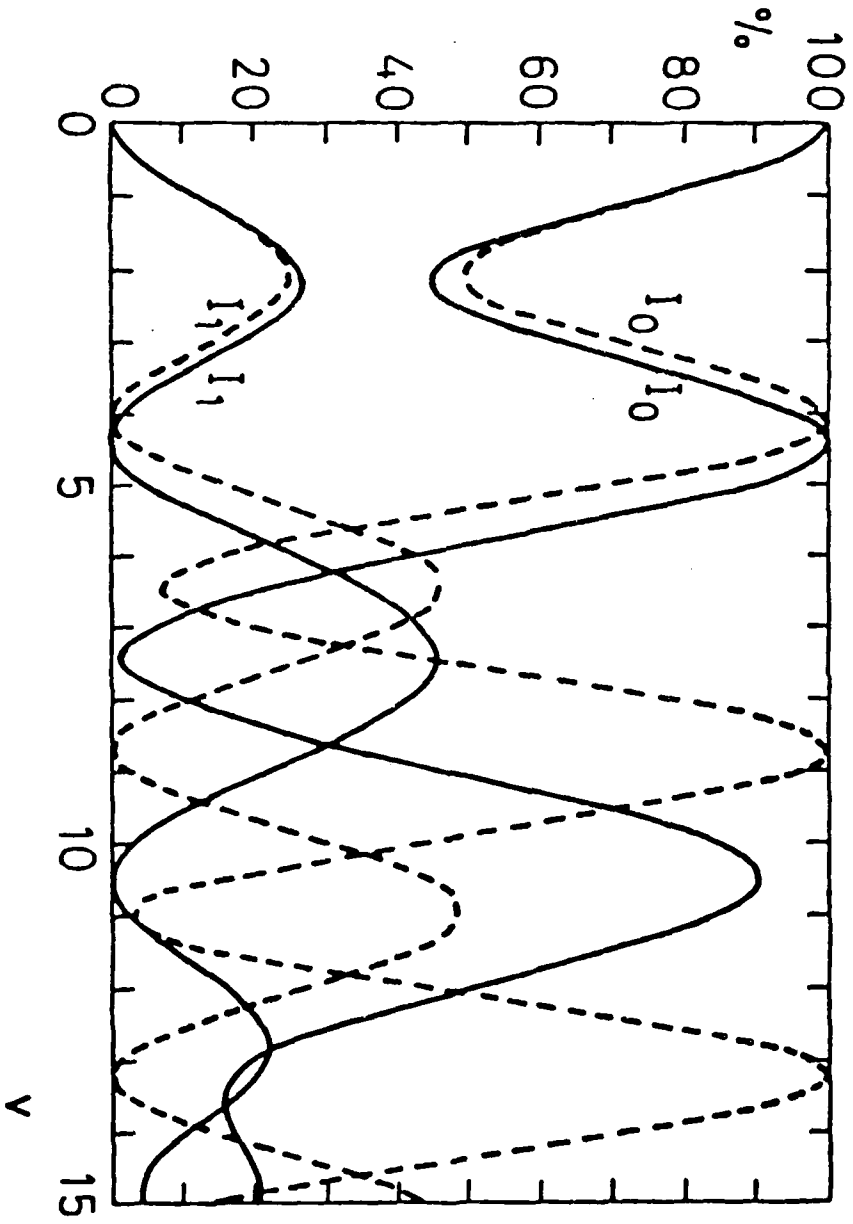


Figure 13

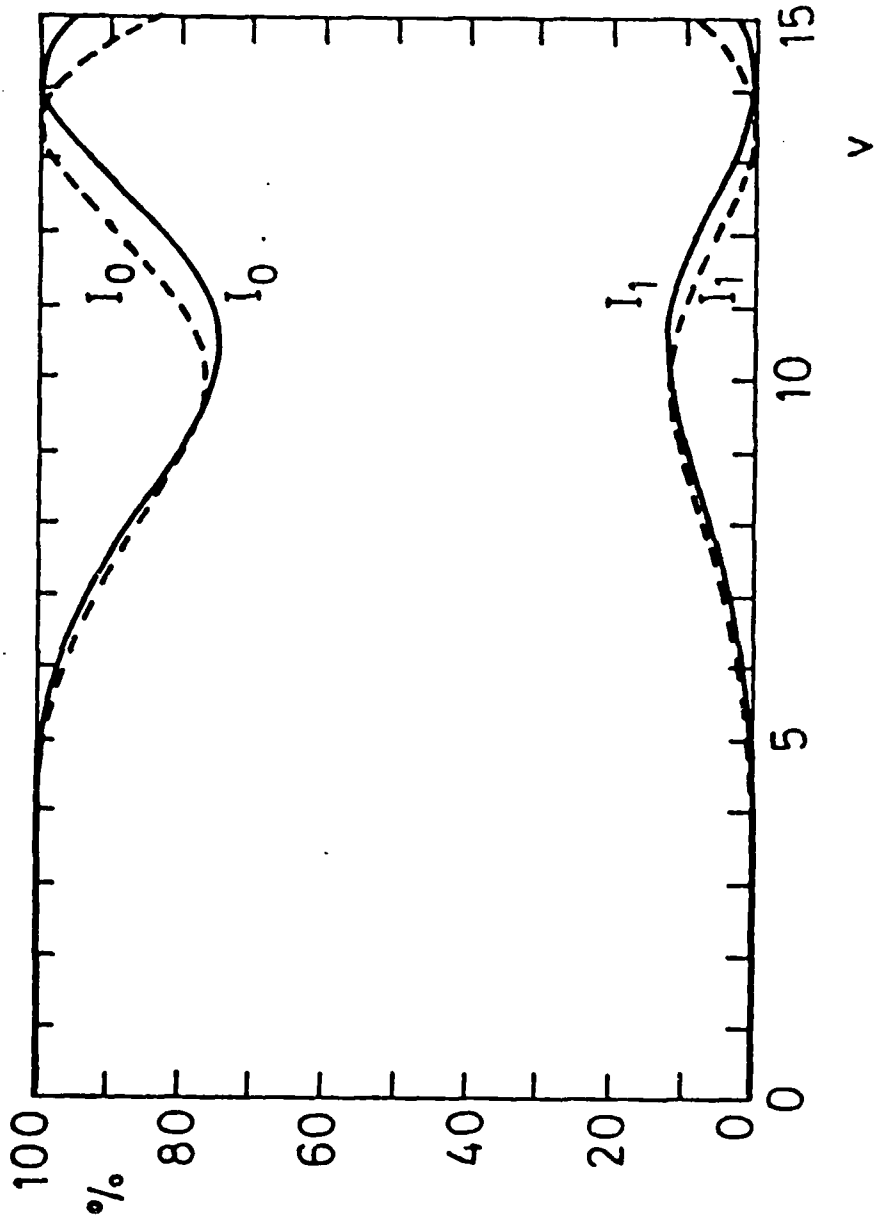


Figure 14

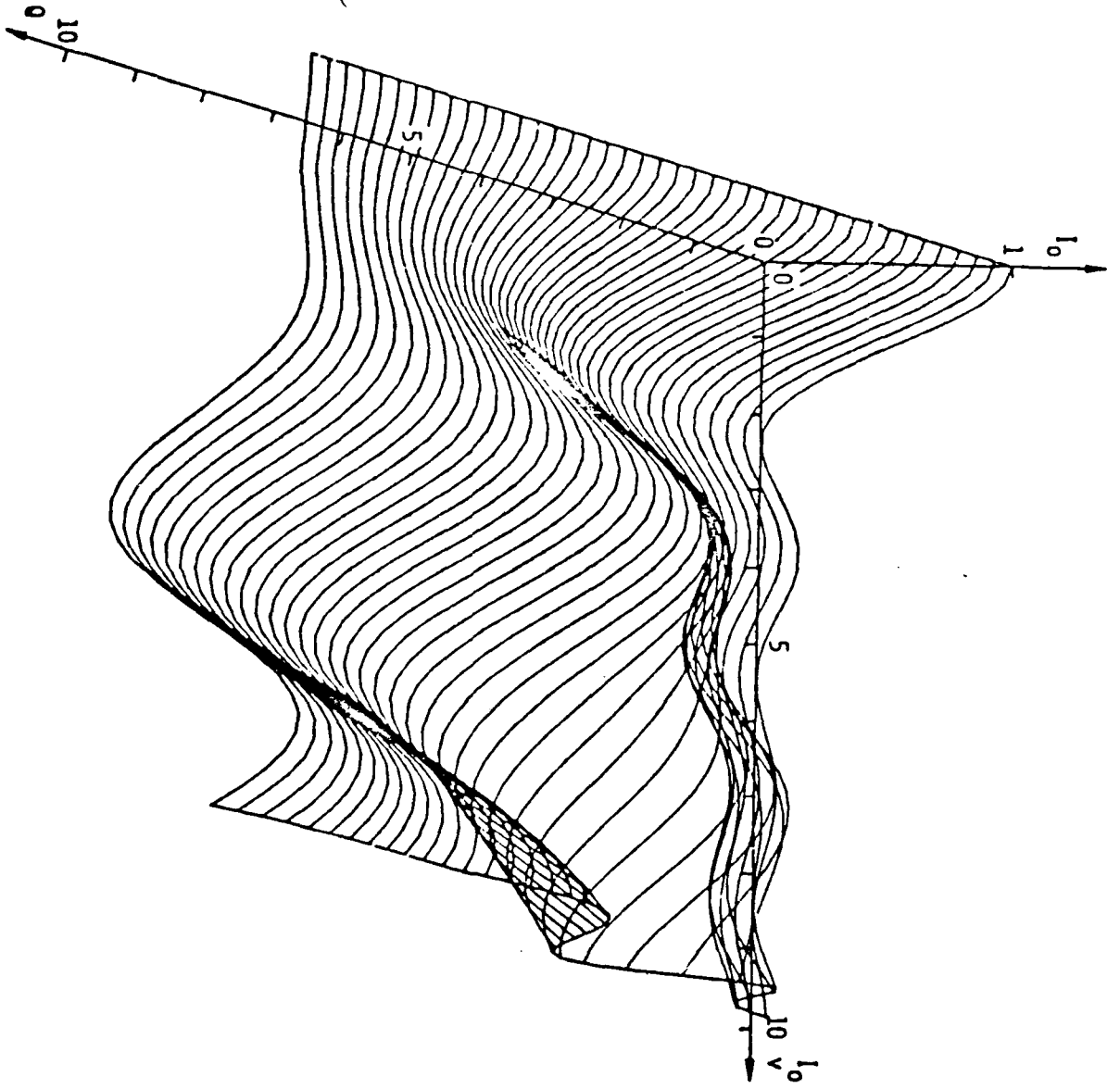


Figure 15

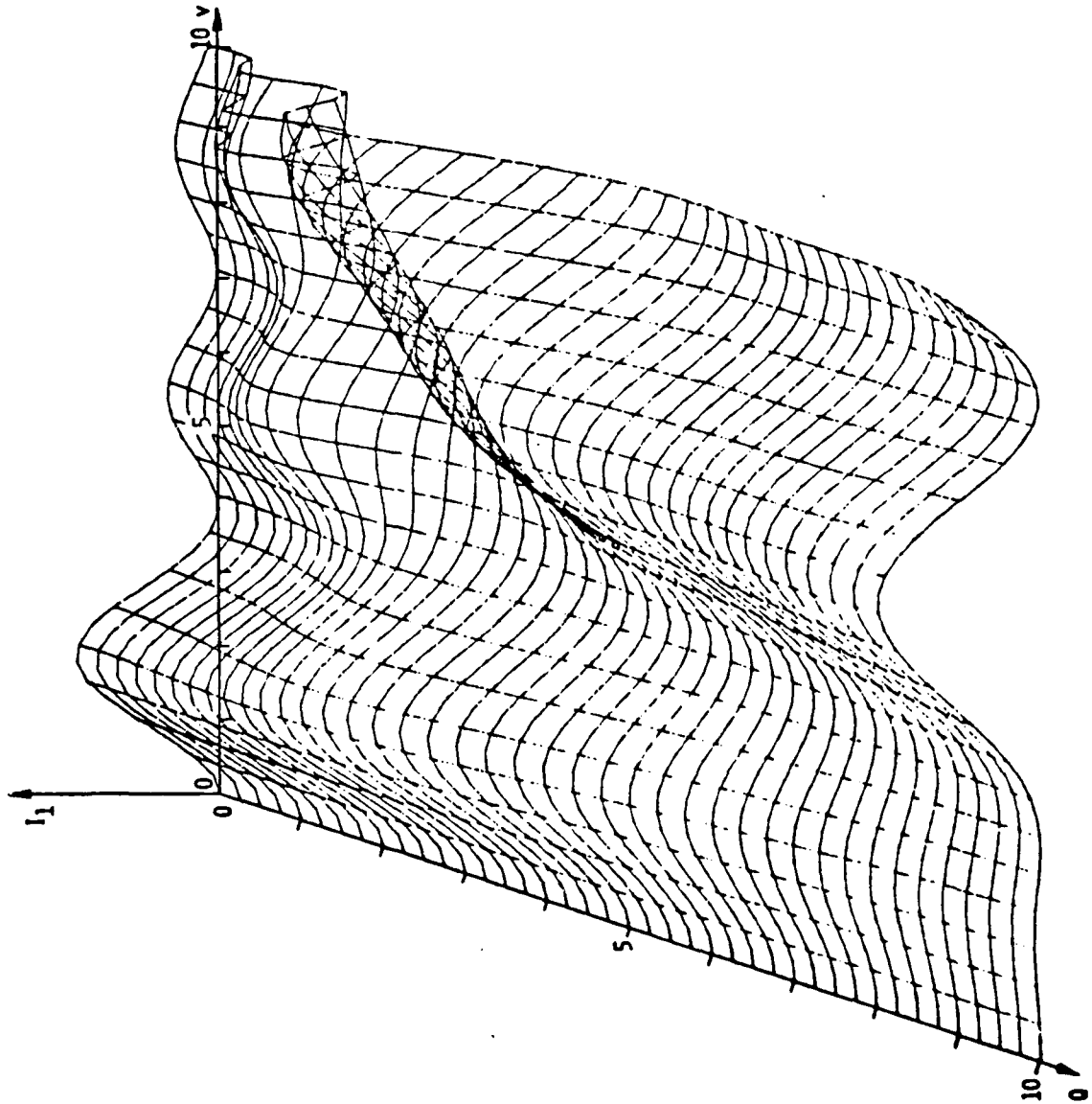


Figure 16

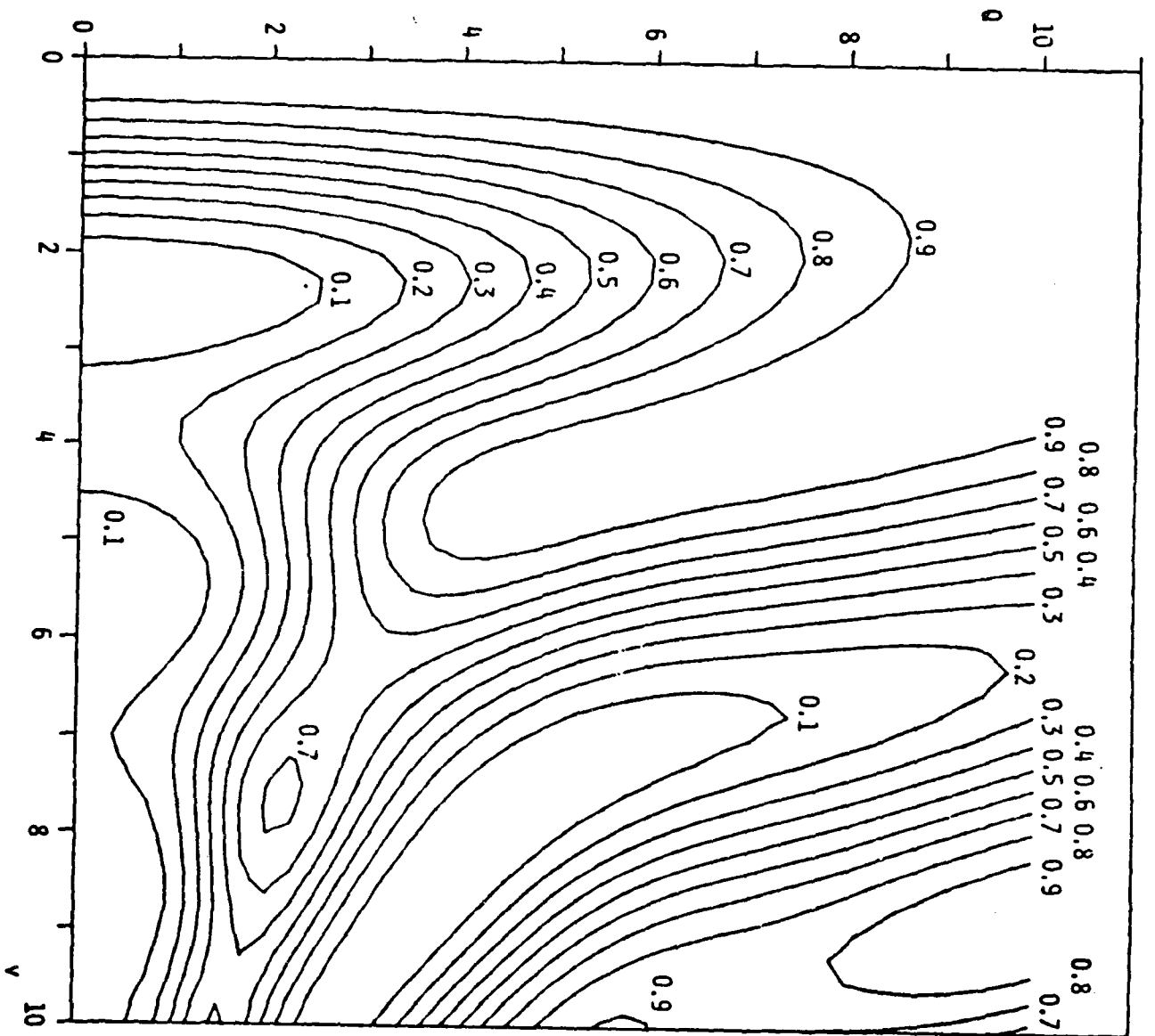


Figure 17

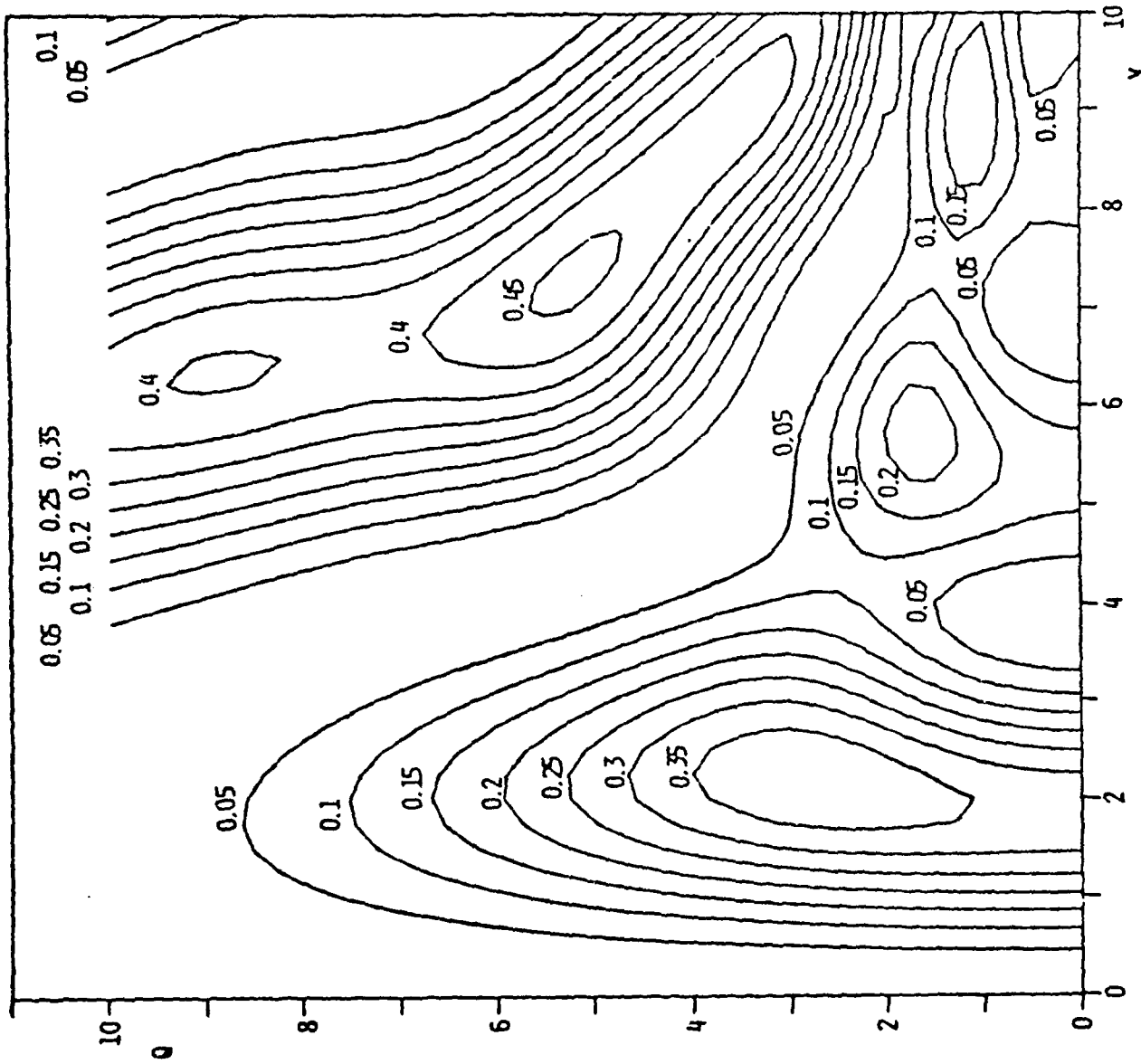


Figure 18

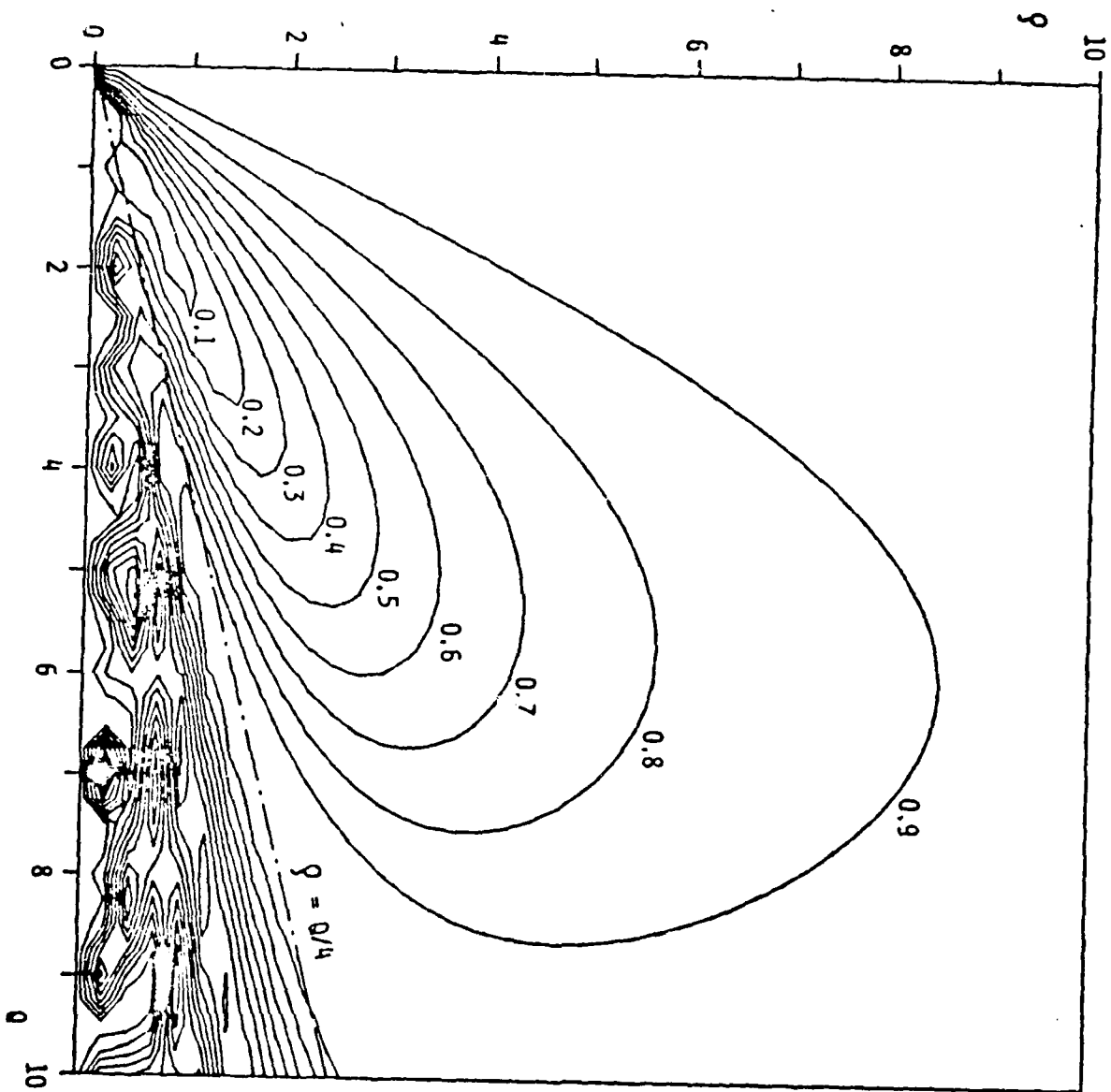


Figure 19

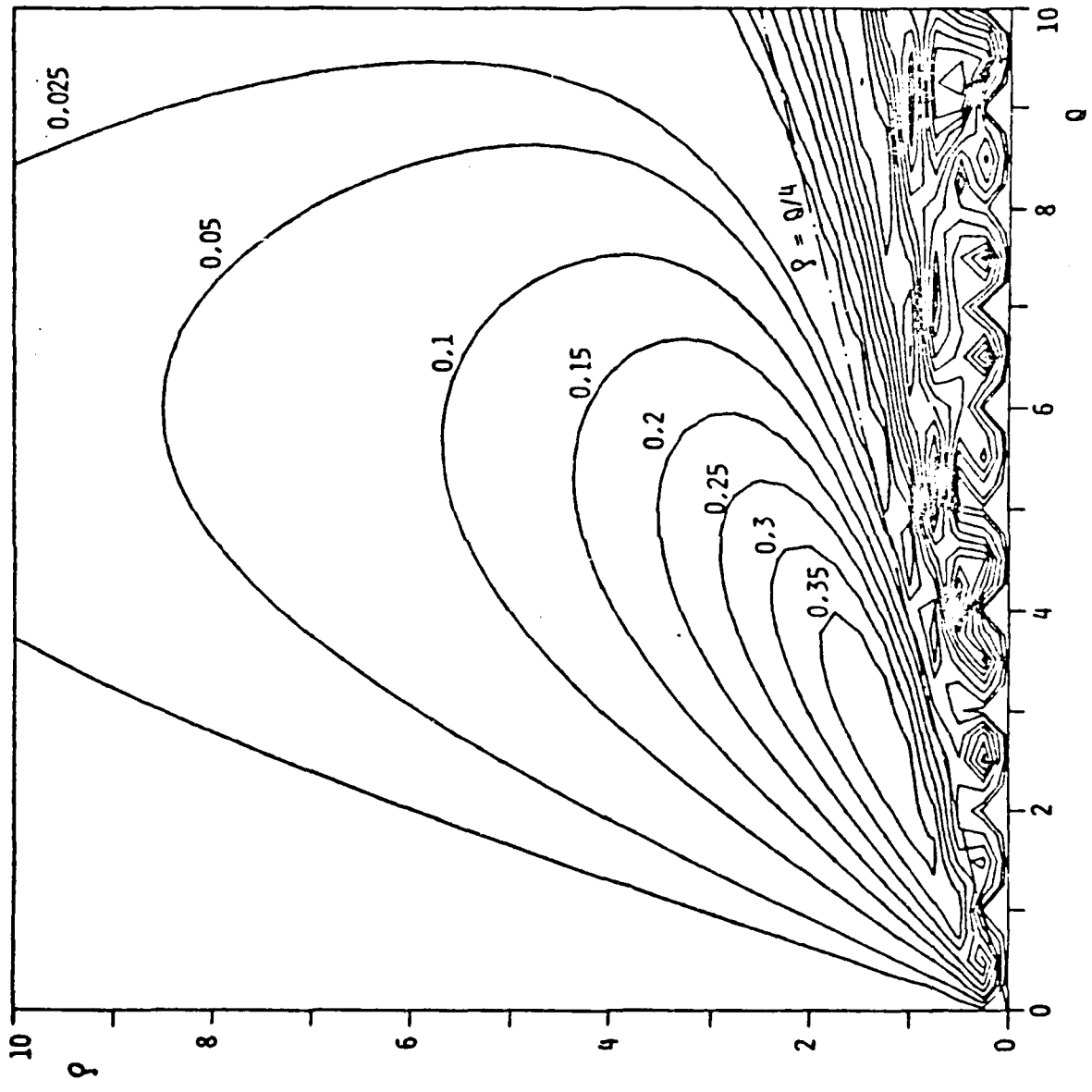


Figure 20

END

DATE

FILMED

8-88

DTIC