

MICROCOPY RESOLUTION TEST CHART  
 BUREAU OF STANDARDS-1963-A

DTIC FILE COPY

AFWL-TR-87-73

AFWL-TR-  
87-73

2

AD-A194 493

**$N_2(A^3\Sigma_u^+)$  BY REACTION OF  $N_2F_4 + H_2$   
IN A SUPERSONIC FLOW**

Y. D. Jones  
N. D. Founds  
D. V. Hibson  
M. R. Palmer

March 1988

Final Report

Approved for public release; distribution unlimited.

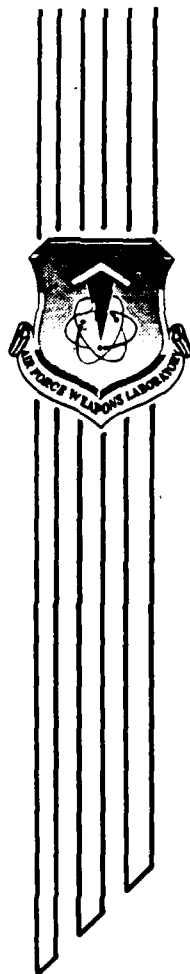

AIR FORCE WEAPONS LABORATORY  
Air Force Systems Command  
Kirtland Air Force Base, NM 87117-6008

DTIC  
ELECTE  
APR 1988

88 4 22 008

UNCLASSIFIED

SECURITY CLASSIFICATION OF THIS PAGE

REPORT DOCUMENTATION PAGE				
1a. REPORT SECURITY CLASSIFICATION Unclassified		1b. RESTRICTIVE MARKINGS		
2a. SECURITY CLASSIFICATION AUTHORITY		3. DISTRIBUTION / AVAILABILITY OF REPORT Approved for public release; distribution unlimited.		
2b. DECLASSIFICATION / DOWNGRADING SCHEDULE				
4. PERFORMING ORGANIZATION REPORT NUMBER(S) AFWL-TR-87-73		5. MONITORING ORGANIZATION REPORT NUMBER(S)		
6a. NAME OF PERFORMING ORGANIZATION Air Force Weapons Laboratory	6b. OFFICE SYMBOL (If applicable) ARBL	7a. NAME OF MONITORING ORGANIZATION		
6c. ADDRESS (City, State, and ZIP Code) Kirtland Air Force Base, New Mexico 87117-6008		7b. ADDRESS (City, State, and ZIP Code)		
8a. NAME OF FUNDING / SPONSORING ORGANIZATION	8b. OFFICE SYMBOL (If applicable)	9. PROCUREMENT INSTRUMENT IDENTIFICATION NUMBER		
8c. ADDRESS (City, State, and ZIP Code)		10. SOURCE OF FUNDING NUMBERS		
		PROGRAM ELEMENT NO. 62601F	PROJECT NO. 3326	TASK NO. 03
				WORK UNIT ACCESSION NO. 85
11. TITLE (Include Security Classification) $N_2(A^3\Sigma^+)$ BY REACTION OF $N_2F_4 + H_2$ IN A SUPERSONIC FLOW				
12. PERSONAL AUTHOR(S) Jones, Y.D.; Founds, N.D.; Hibson, D.V.; and Palmer, M.R.				
13a. TYPE OF REPORT Final	13b. TIME COVERED FROM Jul 84 TO Feb 86	14. DATE OF REPORT (Year, Month, Day) 1988, March	15. PAGE COUNT 42	
16. SUPPLEMENTARY NOTATION TetraFluorohydrazine (diatomic hydrogen) (deuterium) (diatomic nitrogen)				
17. COSATI CODES			18. SUBJECT TERMS (Continue on reverse if necessary and identify by block number)	
FIELD	GROUP	SUB-GROUP	Nitrogen fluorides, Chemical lasers, Nitrogen trifluoride, Metastable nitrogen, Excited nitrogen.	
07	02			
09	03			
19. ABSTRACT (Continue on reverse if necessary and identify by block number) The $N_2F_4 + H_2(D_2)$ reaction has been used to produce $NF(a^1A)$ and $NF(b^1\Sigma)$ in supersonic flow. The extension of that reaction sequence in excess hydrogen is that $N_2(B)$ is produced which relaxes to the $N_2(A)$ electronic state with an energy content of 6.2 eV. The energy storage potential of $N_2(A)$ and subsequent transfer of energy to other molecules, such as NO, SO and IF, makes this production method of extreme interest for laser applications. The device diagnostics, parametric studies and final yield of $N_2(A)$ are described. The yield of $N_2(A)$ is lower than expected from subsonic studies, but the experiments indicate areas of study required to understand the system in greater detail. Keywords: Metastable state; Excitation.				
20. DISTRIBUTION / AVAILABILITY OF ABSTRACT <input type="checkbox"/> UNCLASSIFIED/UNLIMITED <input checked="" type="checkbox"/> SAME AS RPT. <input type="checkbox"/> DTIC USERS			21. ABSTRACT SECURITY CLASSIFICATION Unclassified	
22a. NAME OF RESPONSIBLE INDIVIDUAL Nanette D. Founds		22b. TELEPHONE (Include Area Code) (505) 844-0196	22c. OFFICE SYMBOL AFWL/ARBL	

DD FORM 1473, 84 MAR

83 APR edition may be used until exhausted.  
All other editions are obsolete.SECURITY CLASSIFICATION OF THIS PAGE  
UNCLASSIFIED

UNCLASSIFIED

SECURITY CLASSIFICATION OF THIS PAGE

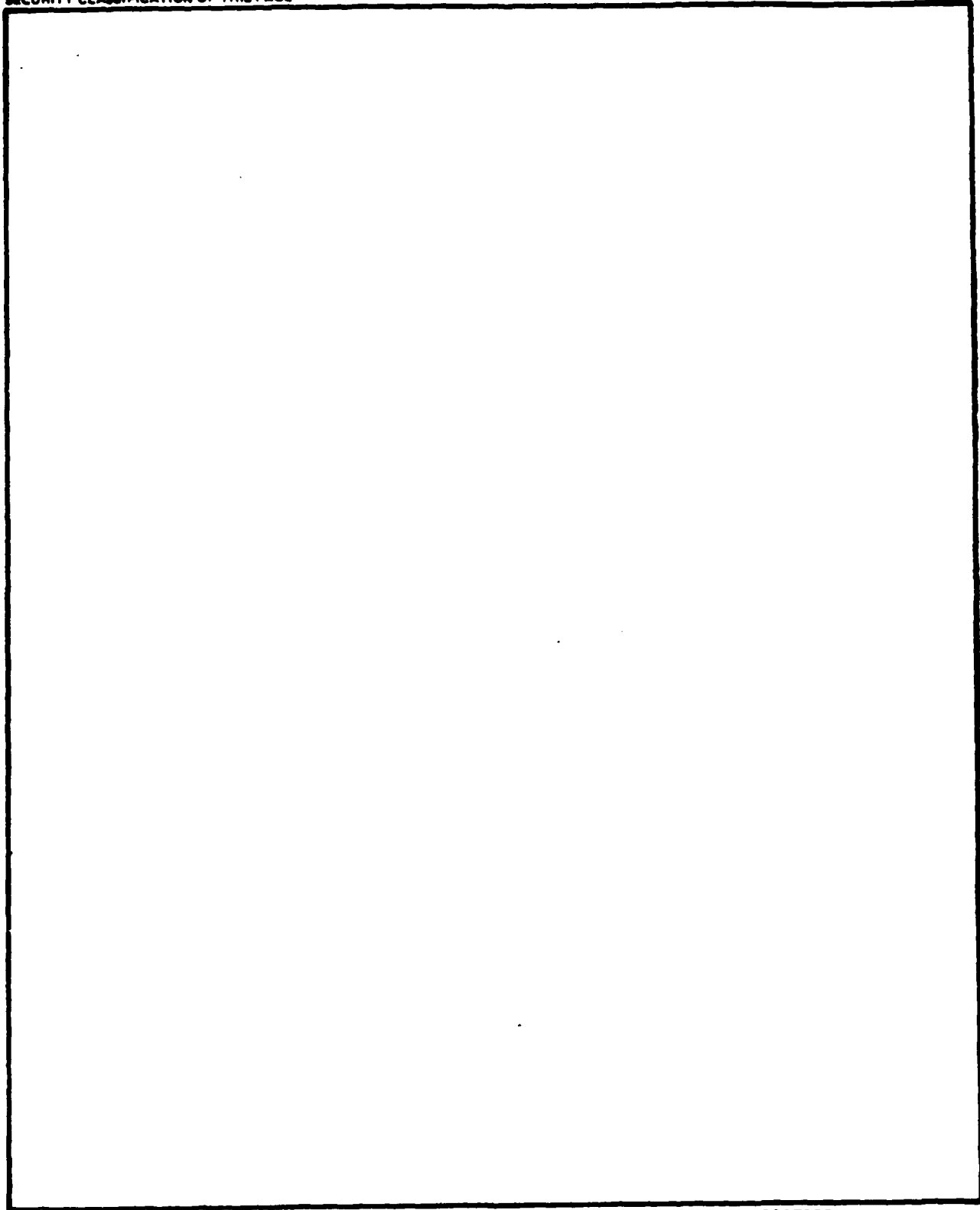

UNCLASSIFIED

SECURITY CLASSIFICATION OF THIS PAGE

ACKNOWLEDGEMENT

The authors would like to thank TSgt James E. Garrett II, Richard J. Barber, Roman L. Martinez, Michael L. Orbock and Robert Hughes for their dedication to the project, their support of the facility, and its operation. We would also like to thank Don Vonderhaar for his tremendous design effort on the device cavity.

Accession For	
NTIS GRA&I	<input checked="" type="checkbox"/>
DTIC TAB	<input type="checkbox"/>
Unannounced	<input type="checkbox"/>
Justification	
By _____	
Distribution/ _____	
Availability Codes	
Dist	Avail and/or Special
A-1	



## CONTENTS

<u>Section</u>		<u>Page</u>
1.0	INTRODUCTION	1
2.0	DEVICE DESCRIPTION	2
	2.1 OVERVIEW	2
3.0	DIAGNOSTICS	5
	3.1 NF( $a^1\Delta$ ) AND NF( $b^1\Sigma$ ) EMISSION MEASUREMENT	5
	3.2 OPTICAL MULTICHANNEL ANALYZER (OMA)	5
4.0	INFRARED (IR) EMISSION MEASUREMENTS	10
	4.1 N <sub>2</sub> (B <sup>3</sup> $\Pi$ g)	10
	4.2 HF AND DF	10
5.0	ULTRAVIOLET (UV) DIAGNOSTICS	11
	5.1 N <sub>2</sub> (C)	11
6.0	GAS PHASE TEMPERATURE DETERMINATION	12
7.0	PARAMETRIC FLOW STUDIES	13
8.0	CONCLUSIONS	24
9.0	RECOMMENDATIONS	26
	REFERENCES	27
	APPENDIX	29
	REFERENCES	32

## FIGURES

<u>Figure</u>		<u>Page</u>
1.	Device schematic.	3
2.	BCL-16 nozzle.	4
3.	NF(a) and NF(b) diagnostic schematic.	6
4.	Experimental arrangement of diagnostics.	7
5.	NF(a) sample scan.	8
6.	NF(b) sample scan.	9
7.	$N_2(B)$ variation with $F_2$ .	14
8.	$N_2(B)$ variation with secondary $H_2$ .	15
9.	$N_2(B)$ variation with $N_2F_4$ .	16
10.	LIF apparatus schematic.	18
11.	Computer generated images from the laser induced fluorescence (LIF) photographs.	19
12.	OMA III spectrum.	21
13.	$N_2(C)$ spectrum.	23

## 1.0 INTRODUCTION

Excited nitrogen has been of major interest for many years because of its highly energetic metastable states (Refs. 1 to 5). The most used method for production of the first excited electronic state of  $N_2$  has been by electrical discharge excitation of Ar and subsequent transfer to  $N_2$  to form  $N_2(A^3\Sigma^+U)$  (Ref. 2). The  $N_2(A)$  molecule contains 6.2 eV of energy which allows for a transfer to molecules that are better suited to lasing than  $N_2$  such as NO, SO and IF. The 2.0 s lifetime of the  $N_2(A)$  state makes it unsuitable for lasing. A purely chemical generation method for  $N_2(A)$  has not previously been shown to produce high densities of the excited state.

This study determined what densities of  $N_2(A)$  could be produced using  $NF_2 + H_2$  by the following basic reactions:

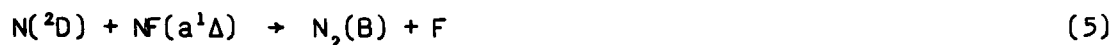

A more detailed reaction scheme is given in the Appendix. The study was performed in supersonic flow to minimize the operating gas phase temperature and provide preliminary information on  $N_2(A)$  in a possible lasing media. Previous work indicated that this reaction sequence in a subsonic flow tube produced excited  $N_2$  (Ref. 3). However, the reaction had not been used to produce densities greater than  $10^8$  molecules/cc in the flow tube low pressure condition.

## 2.0 DEVICE DESCRIPTION

### 2.1 OVERVIEW

The overall experimental system consisted of a 316L stainless steel chamber with viewing ports on four sides. Figure 1 shows a view of the chamber with positions shown for the gas input plumbing. The chamber was exhausted into a cooled diffuser in the transition section and two heat exchangers. The device was evacuated using two Kinney 850 cfm pumps with two M&D Pneumatics 2700 cfm blowers for a system total of 7,100 cfm.

The BCL-16 nozzle was positioned on the chamber wall with the gas inputs. The BCL-16 nozzle cross section is shown in Fig. 2. The nozzle and flow systems have been discussed in detail in previous reports (Refs. 4, 5). The BCL-16 nozzle was developed for HF/DF laser application (Ref. 4) and studied for those same systems (Ref. 6). For the  $N_2F_4 + H_2$  system the combustor portion of the assembly nozzle was operated at design conditions to produce F atoms. The hydrogen or deuterium and fluorine were injected into the combustor along with He diluent at a molar ratio of  $F_2 : D_2 : He$  of approximately 1:2:50.

The combustor portion of the nozzle was  $N_2$ -cooled by an external copper collar around the body of the combustor. The internal temperature of the combustor was maintained by using a Ni liner with an air gap between the outer diameter of the liner and inner diameter of the combustor wall. This configuration was determined by extensive testing with  $LaB_6$  and alumina liners. The  $LaB_6$  and alumina liners failed after minimal usage. The result was that debris from the liners plugged the primary nozzles preventing further operation. The Ni liner lasted over 10 test sequences. A study of the mixing performance of the BCL-16 nozzle was performed under reactive conditions. The preliminary summary of the study will be presented under the Results section of this report.

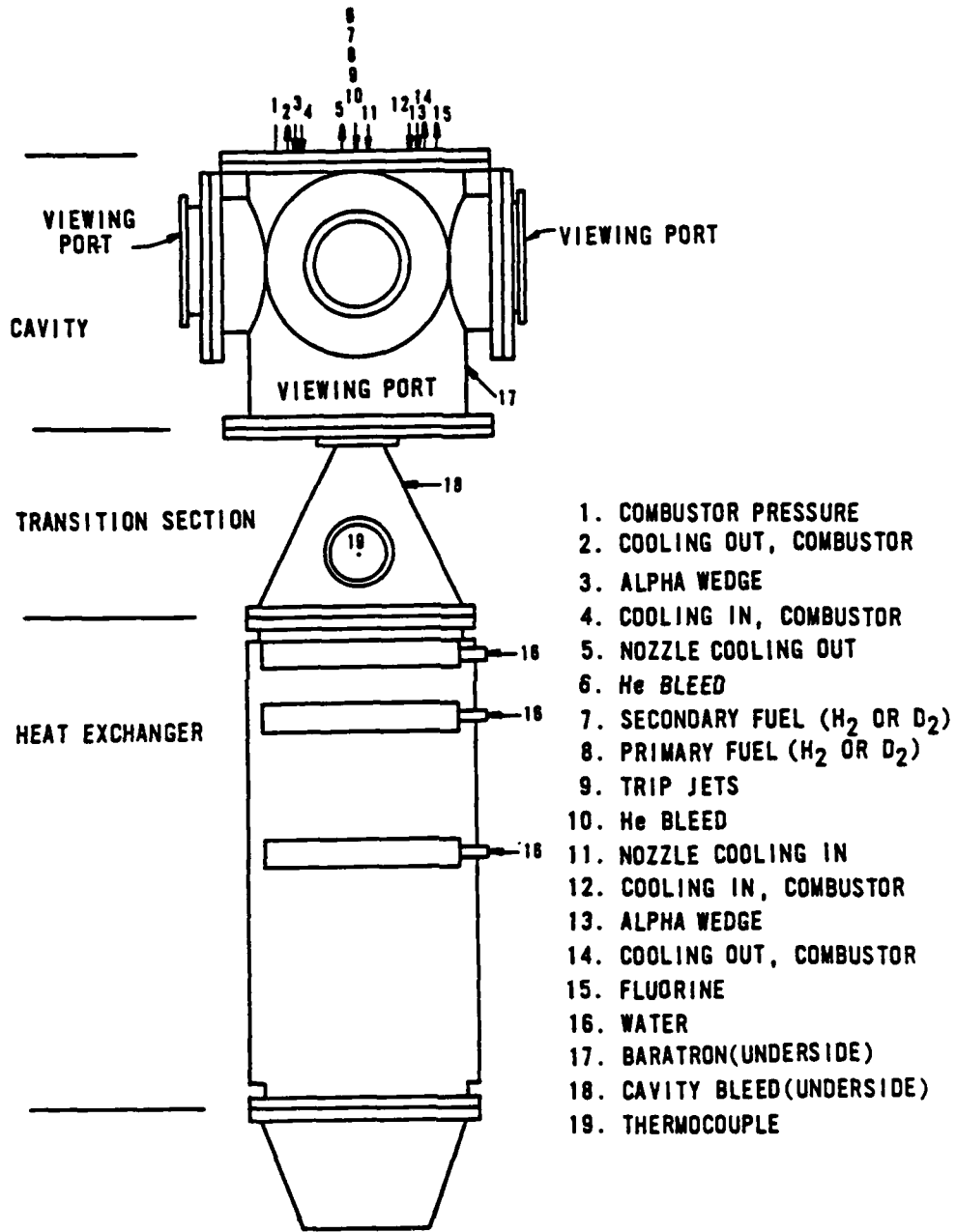

Figure 1. Device schematic.

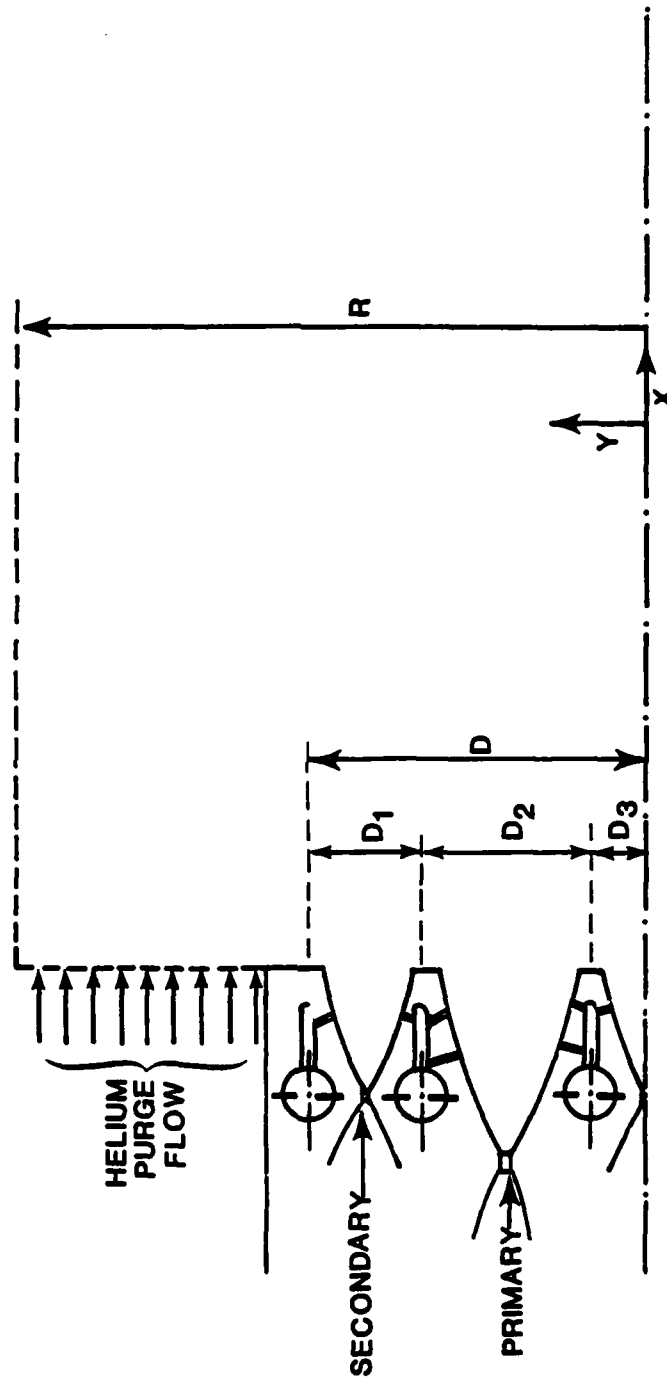

Figure 2. BCL-16 nozzle.

### 3.0 DIAGNOSTICS

#### 3.1 NF(a<sup>1</sup>Δ) AND NF(b<sup>1</sup>Σ) EMISSION MEASUREMENT

The NF(a<sup>1</sup>Δ) diagnostic was an extremely important part of the device performance analysis and has been described previously (Ref. 7). The overall arrangement of the NF(a) and NF(b) diagnostics is shown in Fig. 3. The 874.2 nm emission from the NF(a-X) transition was detected via a 38.1 cm long spatial filter with 0.17 cm-dia orifices coupled to a fused silica fiber optic. The fiber optic was bifurcated so that one end was fed into the NF(b) diagnostic, which monitored the NF(b-X) transition at 528.8 nm. The allowed simultaneous detection of NF(a) and NF(b) within the same viewing volume. The flame shape was photographed and digitized to determine the actual viewing volume (Fig. 4).

Errors for the diagnostics were based upon the extent of interferences from other emissions, uncertainties in the lifetimes and calibration errors. The error for the NF(b<sup>1</sup>Σ) diagnostic was determined to be ±10% with a range of 10<sup>11</sup> to 10<sup>13</sup> molecules/cc. For the NF(a<sup>1</sup>Δ) diagnostic, the error was larger because of the interferences from other emissions in the system and was estimated at ±20% with a range of 10<sup>14</sup> to 10<sup>16</sup> molecules/cc.

The spatial filter was mounted on a remotely operated translation stage with a linear voltage displacement transducer (LVDT) to accomplish scans across the centerline of the flow field of the device with a known position. Sample scans of the NF(a<sup>1</sup>Δ) and NF(b<sup>1</sup>Σ) emissions are shown in Figs. 5 and 6. Scans were made starting at the nozzle exit plane (NEP). The scan was not begun until all flows were stable.

#### 3.2 OPTICAL MULTICHANNEL ANALYZER (OMA)

The OMA III 1460R system (EG&G PAR) was used to monitor the change in emission over a wide wavelength range (usually 300-900 nm) at a fixed point within the device. The OMA III system and its calibration has been described in Ref. 5. This diagnostic was only used to determine volume-averaged changes of the excited state production in the device with respect to flow rate changes.

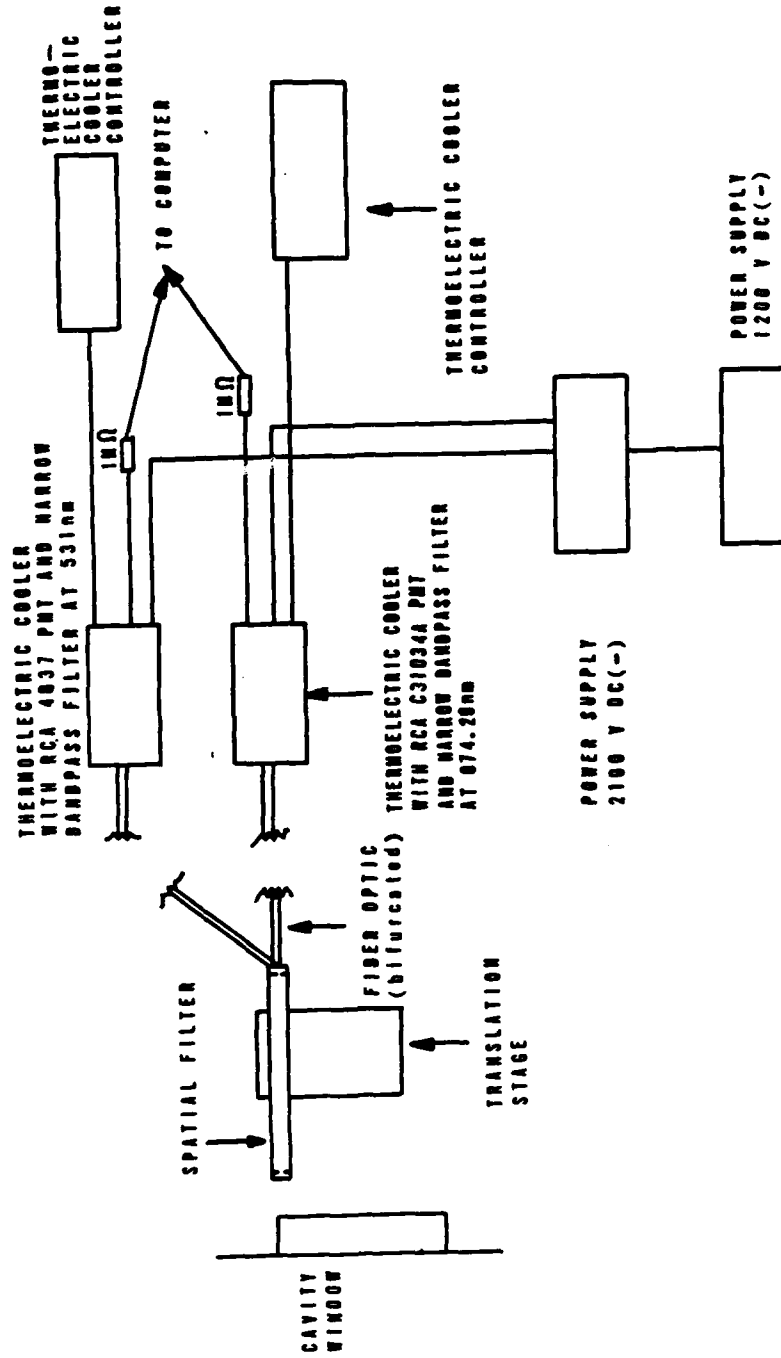

Figure 3. NF(a) and NF(b) diagnostic schematic.

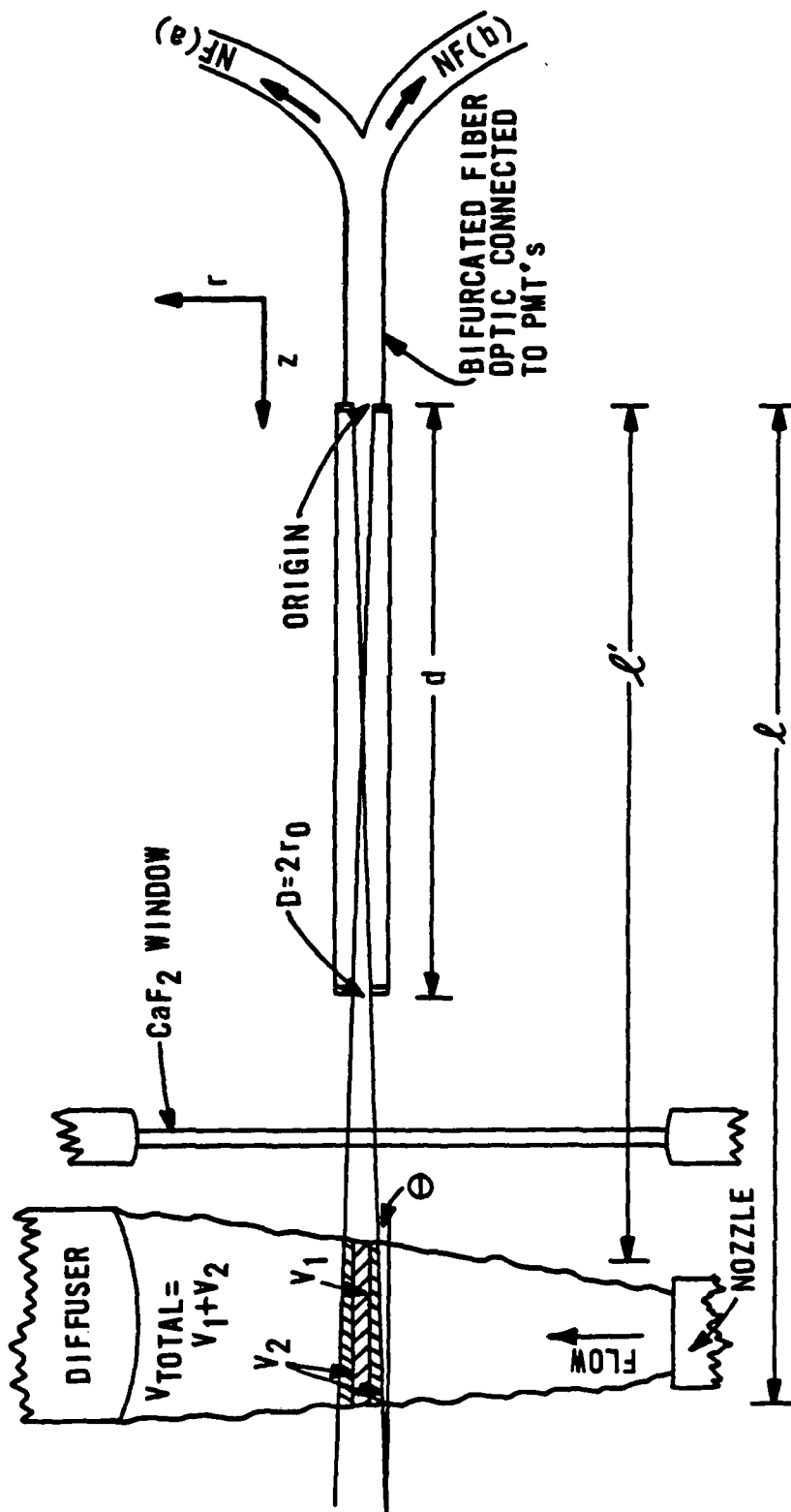

Figure 4. Experimental arrangement of diagnostics.

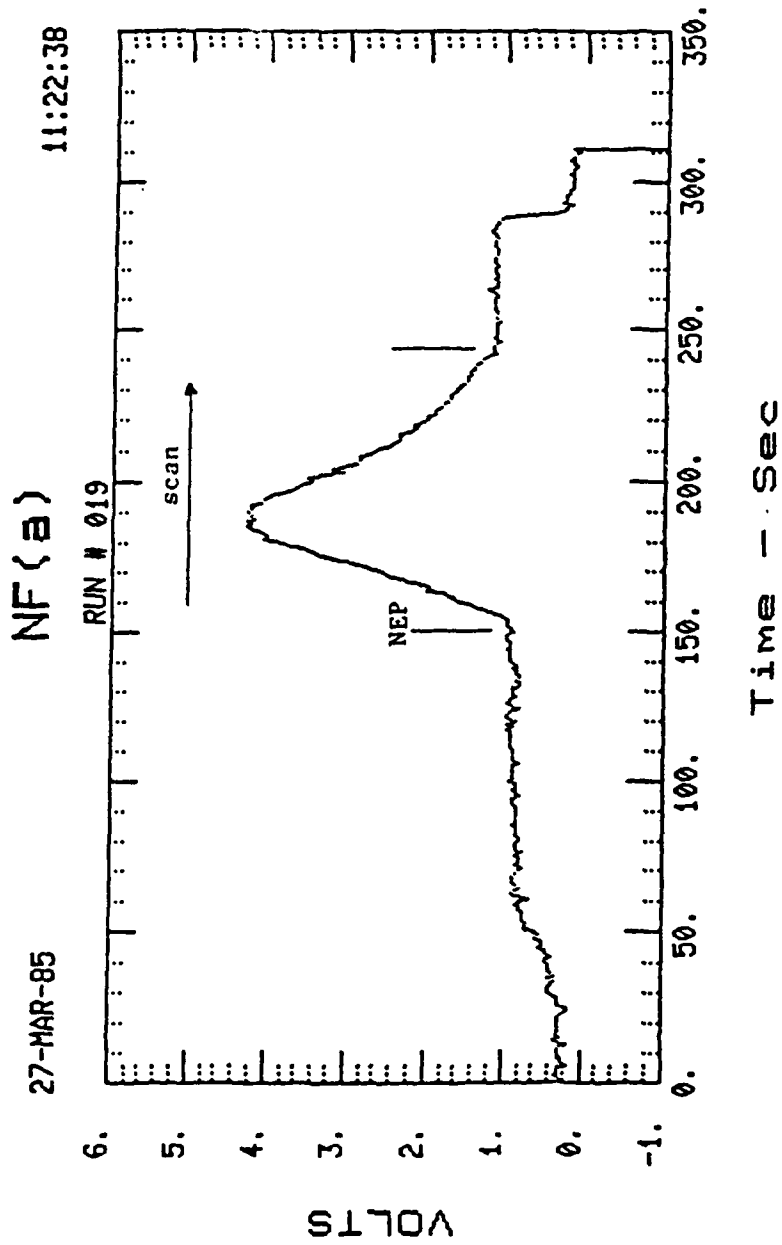

Figure 5. NF(a) sample scan.

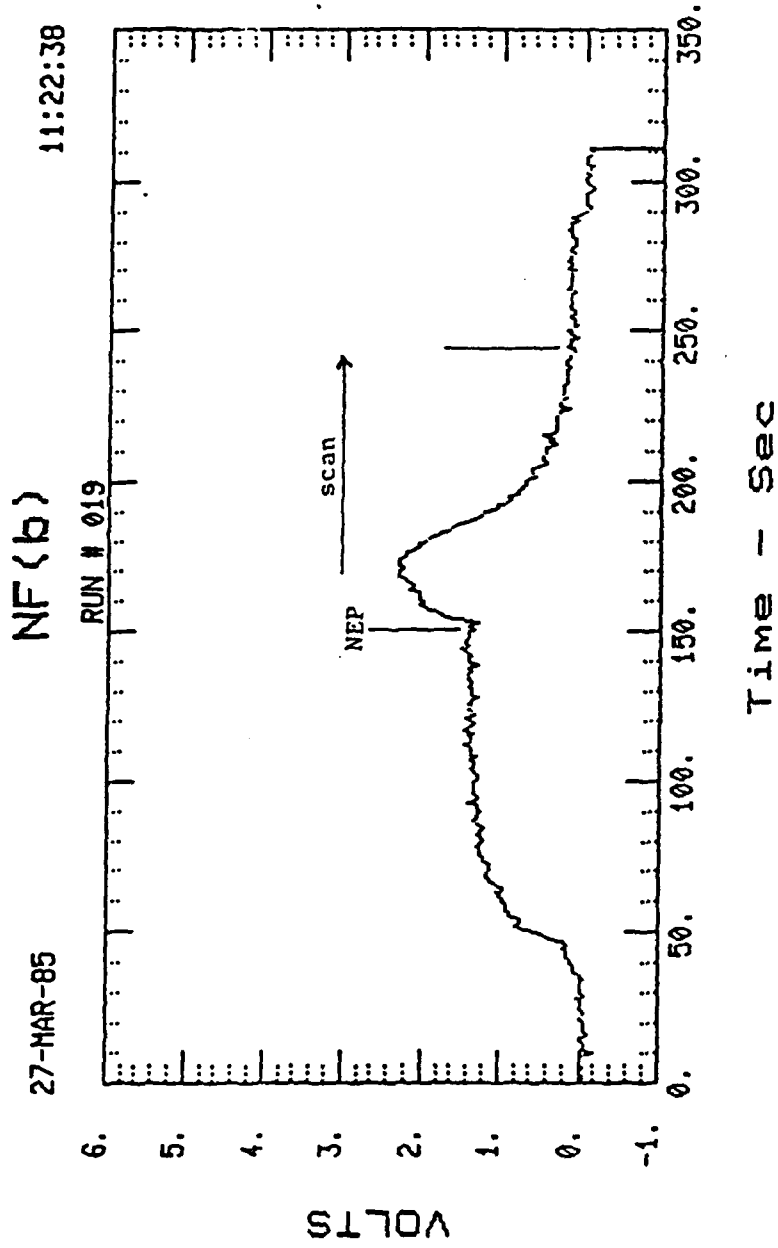

Figure 6. NF(b) sample scan.

## 4.0 INFRARED EMISSION MEASUREMENTS

4.1  $N_2(B^3\Pi_g)$ 

To determine the contribution to the total  $N_2(B)$  population by the infrared (IR) vibrational transitions, a 0.3 m monochromator (Acton) equipped with a 1.0  $\mu\text{m}$  blazed, 1200 1/mm grating was used. The emission was collected using a fused silica fiber optic which was rectangular on one end to match the monochromator slit. The collection volume was defined by a spatial filter. Scans from 900 nm to 1.5  $\mu\text{m}$  were performed at a fixed point in the middle of the flow. The diagnostic used an intrinsic Ge detector (Applied Detector Corporation, Model 403L). The entire diagnostic was calibrated using a FEL-type standard lamp (Eppley Laboratories) and with a blackbody (Infrared Industries Inc.). The number density was compared to the  $N_2(B)$  visible emission measured at the same point in the flow using the calibrated OMA III. The  $N_2(B)$  population could be determined to within  $\pm 15\%$ .

## 4.2 HF AND DF

Vibrationally excited HF and DF were produced in the combustor and in subsequent reactions of  $NF_2$ . The rotational distribution of the HF(DF) produced was of interest in terms of evaluating possible interference with other diagnostics and in determining the gas phase temperature assuming rotational equilibrium. The HF(DF) emission was studied with the OMA III to its limit of 900 nm. Further into the IR, HF(DF) emission was examined using the 0.3 m monochromator and detector described in the previous paragraph. A 3.0  $\mu\text{m}$  blazed grating was used. Only relative peak heights were of interest from this diagnostic.

## 5.0 ULTRAVIOLET (UV) DIAGNOSTICS

5.1 N<sub>2</sub>(C)

The N<sub>2</sub>(C-B) emission is due to the creating of the C state from N<sub>2</sub>(A) pooling as given by

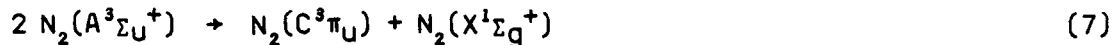

The rate for the pooling reaction is very fast,  $1.0$  to  $2.6 \times 10^{-10}$  cm<sup>3</sup>/molecule-s (Ref. 8), ultimately determining the maximum N<sub>2</sub>(A) concentration which may be produced. The lifetime of the N<sub>2</sub>(C) state is  $3.92 \times 10^{-8}$  (Ref. 9). Knowing the pooling rate, the N<sub>2</sub>(A) concentration may be calculated from a known N<sub>2</sub>(C) number density. This diagnostic was used as a cross-check on N<sub>2</sub>(A) densities determined by N<sub>2</sub>(B-A) emission. Contaminants in the N<sub>2</sub>F<sub>4</sub> lead to NO emission interfering with many of the known N<sub>2</sub>(C) peaks during experimental testing.

The apparatus used was a 1.0 m vacuum ultraviolet (VUV) monochromator (Acton) equipped with MgF<sub>2</sub> windows. Scans were performed from 250 to 400 nm using a fused silica fiber optic. The detection was via a Hamamatsu R928 photo-multiplier tube (PMT). Calibration was performed using the FEL-type standard lamp and narrow bandpass filters to determine the systems response at specific wavelengths. Blocking filters were used to minimize interference from UV scatter. The OMA III system was used to confirm peaks at wavelengths greater than 300 nm. Because of the large interference from NO(A-X) emission in the US, this diagnostic was less accurate than measurement of N<sub>2</sub>(B). The N<sub>2</sub>(C) population could be determined to within  $\pm 30\%$ .

## 6.0 GAS PHASE TEMPERATURE DETERMINATION

Scans of the HF rotational distribution were performed on several representative tests. The relative intensity plotted versus  $J(J + 1)$  yields a gas phase temperature for that area of the flow field. Scans were performed using the apparatus as described in the IR emission section. The HF(0-1) data were rejected because of self-absorption. Temperatures in the flow field ranged from 1200 to 1600 K. Use of the Boltzmann distribution to determine gas phase temperature assumes an equilibrium exists. Errors because of nonequilibrium as well as some self-absorption are estimated at 200 percent.

## 7.0 PARAMETRIC FLOW STUDIES

Extensive flow variation studies were performed with the BCL-16 nozzle. The purpose of the flow studies was to begin with a computer-modeled set of combustor conditions and optimize the combustor performance. One the combustor was optimized and, thus, the F production, the H<sub>2</sub> (or D<sub>2</sub>) and NF<sub>2</sub> were varied to optimize N<sub>2</sub>(B-A) emission. To optimize to combustor, actual H atom production was monitored. Hydrogen was added through the secondary jets and NO added through the trip jets. The H + NO reaction produces a red emission from the relaxation of excited HNO which is formed. The gas phase titration to determine the H atom level has been described in Ref. 5.

The next series of tests involved setting the reagent flows at a computer-modeled set of conditions and optimizing one reagent at a time. Once a specific flow was optimized the other flows were one at a time varied to achieve the highest N<sub>2</sub>(B) level. Then the original reagent flow was checked to ensure maximum intensity. Figures 7 through 9 show samples from the test series. The N<sub>2</sub>(B-A) emission appeared to be relatively insensitive to most flows except N<sub>2</sub>F<sub>4</sub> and F<sub>2</sub>. Even the response to N<sub>2</sub>F<sub>4</sub> flow change was smaller than might be anticipated (Fig. 9).

One series of tests were designed to determine if by using D<sub>2</sub> in place of H<sub>2</sub> in the secondary jets, the NF(b) production could be minimized as a parasitic pathway and, thus, N<sub>2</sub>(B-A) increased. The overall result was that with D<sub>2</sub> the N<sub>2</sub>(B) number density increased from 5 to 10 times the [N<sub>2</sub>(B)] previously achieved with H<sub>2</sub>. The increase may be also because of improved mixing from increased penetration of the jets -- the jet penetration being dependent upon the molecular weight of the gas. The decoupling of the chemistry and mixing issues has not been completed; however, some investigation of the mixing in the BCL-16 nozzle was performed. The method used is discussed in Ref. 6. A sheet of Ar<sup>+</sup> laser light, 514.5 nm was directed into the device. The 514.5 nm wavelength excites I<sub>2</sub> that is injected through each set of jets, such as primary, secondary or trip, at separate times. The fluorescence is then photographed as the sheet of light is translated across the NEP. A

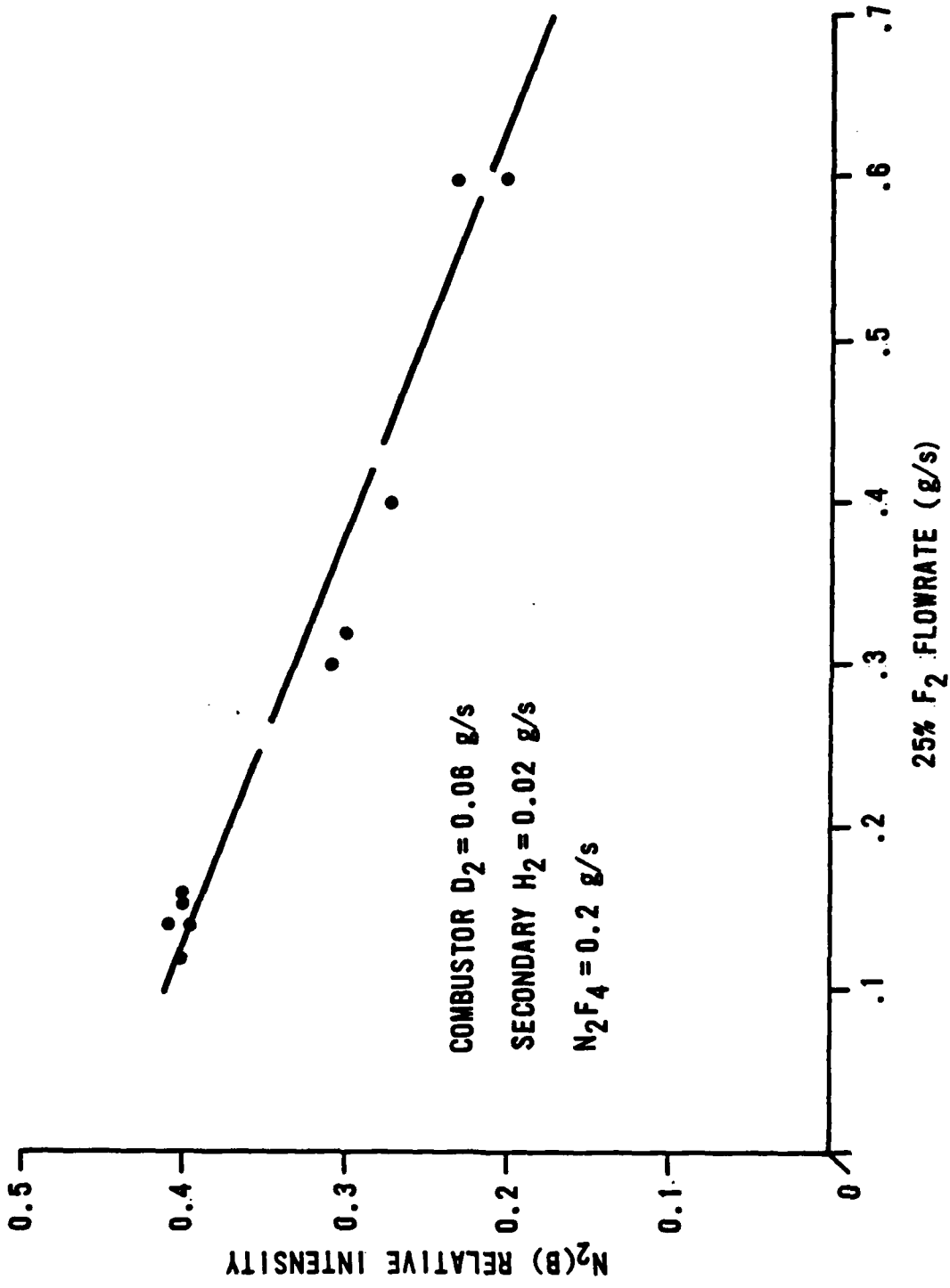

Figure 7.  $N_2(B)$  variation with  $F_2$ .

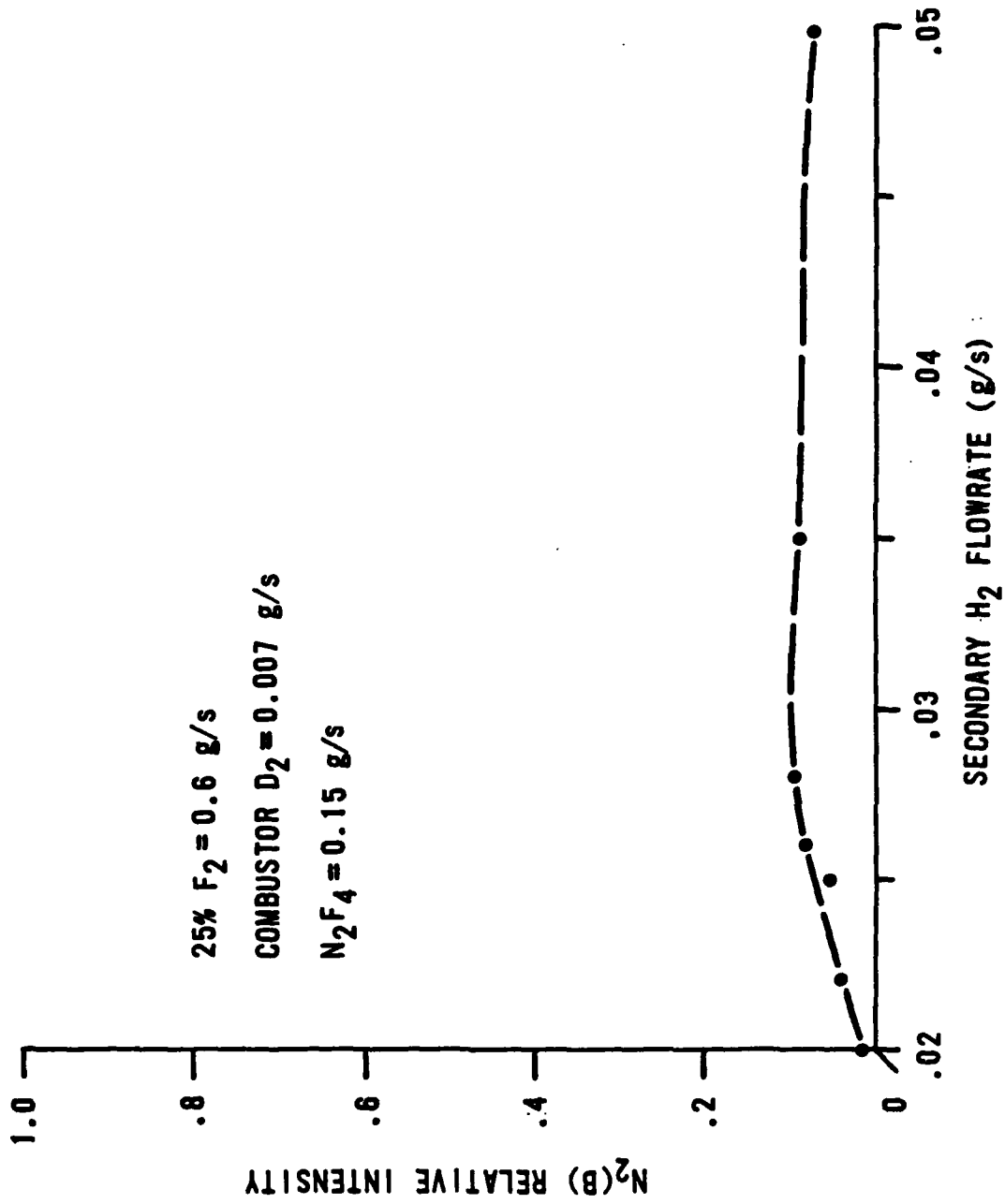

Figure 8. N<sub>2</sub>(B) variation with secondary H<sub>2</sub>.

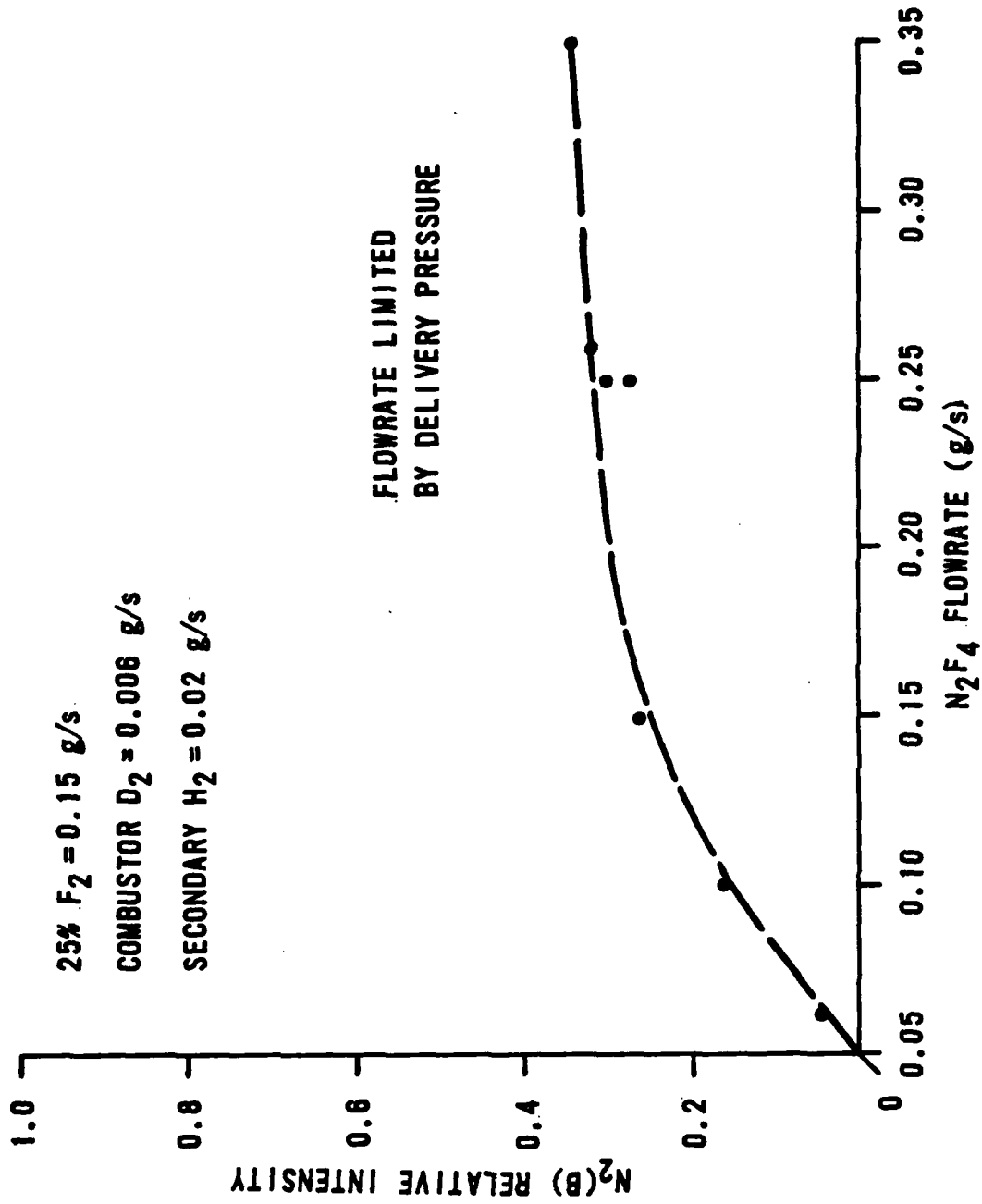

Figure 9.  $N_2(B)$  variation with  $N_2F_4$ .

diagram of the experimental setup is shown in Fig. 10. The photographs from each set of jets were digitized and combined to determine the over-lap areas. The area of overlap indicates where the jets are mixing. Care was taken to use inert carrier gases which would be similar to the molecular weight of the actual reactive flow gases. Figure 11 shows the result of the photograph overlapping at one position in the flow field. The area of overlap is small indicating poor mixing. The quantitative effect is not easily determined by these cold flow investigations. The cold flow studies do indicate, however, that mixing is a significant factor causing low  $N_2(A)$  production.

Table 1 gives a set of sample test conditions which yielded high  $N_2(B)$  number densities and compare  $D_2$  versus  $H_2$  secondary injection. The concentrations of  $NF(a^1\Delta)$  and  $NF(b^1\Sigma)$  are given in addition to the  $N_2(B)$  concentrations. The  $NF(a^1\Delta)$  and  $NF(b^1\Sigma)$  concentrations are peak values taken from the scanning diagnostic, whereas the  $N_2(A)$  concentration is volume averaged over a larger portion of the flame.

The  $N_2(A)$  yield calculated from the maximum production set of flow rates (using  $N_2(B)$  populations) and based upon initial  $N_2F_4$  flow is  $10^{-3}\%$ . The flow rates for this case are listed first in Table 1. The yield of  $NF(a^1\Delta)$  is also lower than predicted from earlier studies (Ref. 10). The yield for  $NF(a^1\Delta)$  never exceeded 35 percent in any test sequence. This indicated the branching ratio might also not be correct. Flow tube studies were performed in this laboratory which confirmed the branching ratio might indeed be on the order of 35 percent to  $NF(a^1\Delta)$ .\*

To confirm that the  $N_2(A)$  population was represented by the  $N_2(B)$  visible emission as shown in a sample OMA III scan (Fig. 12), the IR portion of the  $N_2(B)$  emission was examined. The prominent features of the  $N_2(B)$  spectrum are the 1-0, 0-0 and 0-1 peaks between 850 and 1250 nm. The only peak which was

\*Communication with Dr. Miles R. Palmer regarding a forthcoming publication, Sept 1986.

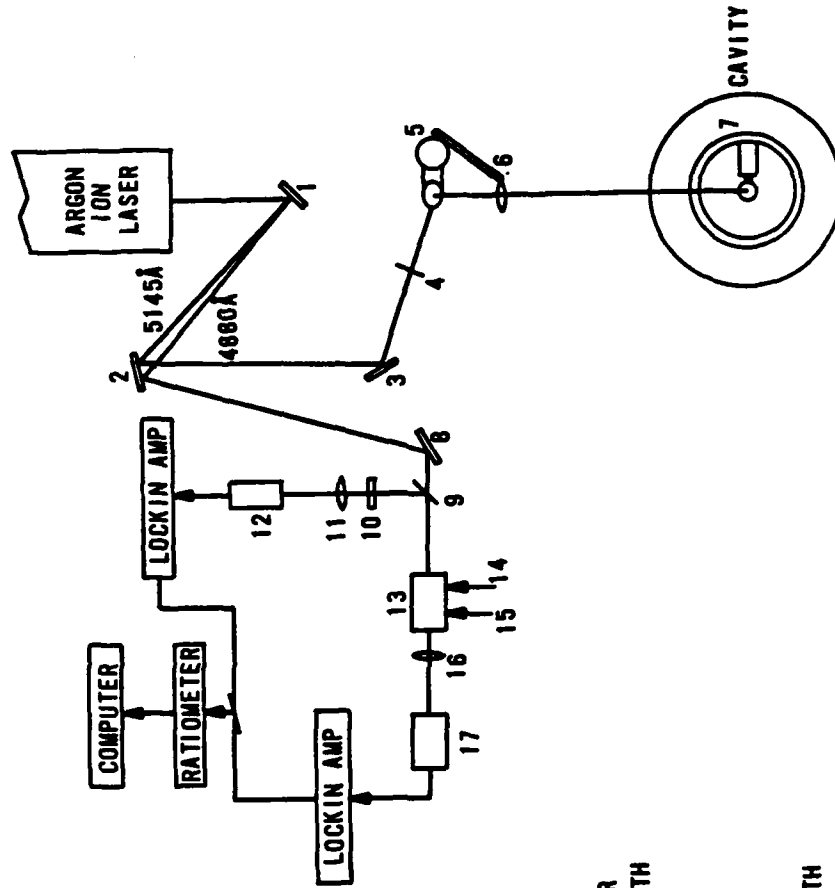

1. GRATING
2. MIRROR
3. MIRROR
4. IRIS DIAPHRAGM
5. BEAM STEERER
6. LENS; 1m FOCAL LENGTH
7. RASTER MIRRORS
8. MIRROR
9. BEAM SPLITTER
10. NEUTRAL DENSITY FILTER
11. LENS, ~7cm FOCAL LENGTH
12. Ge PHOTODIODE
13. I<sub>2</sub> CELL
14. PRESSURE TRANSDUCER
15. THERMOCOUPLE
16. LENS, ~7cm FOCAL LENGTH
17. Ge PHOTODIODE

Figure 10. LIF apparatus schematic.

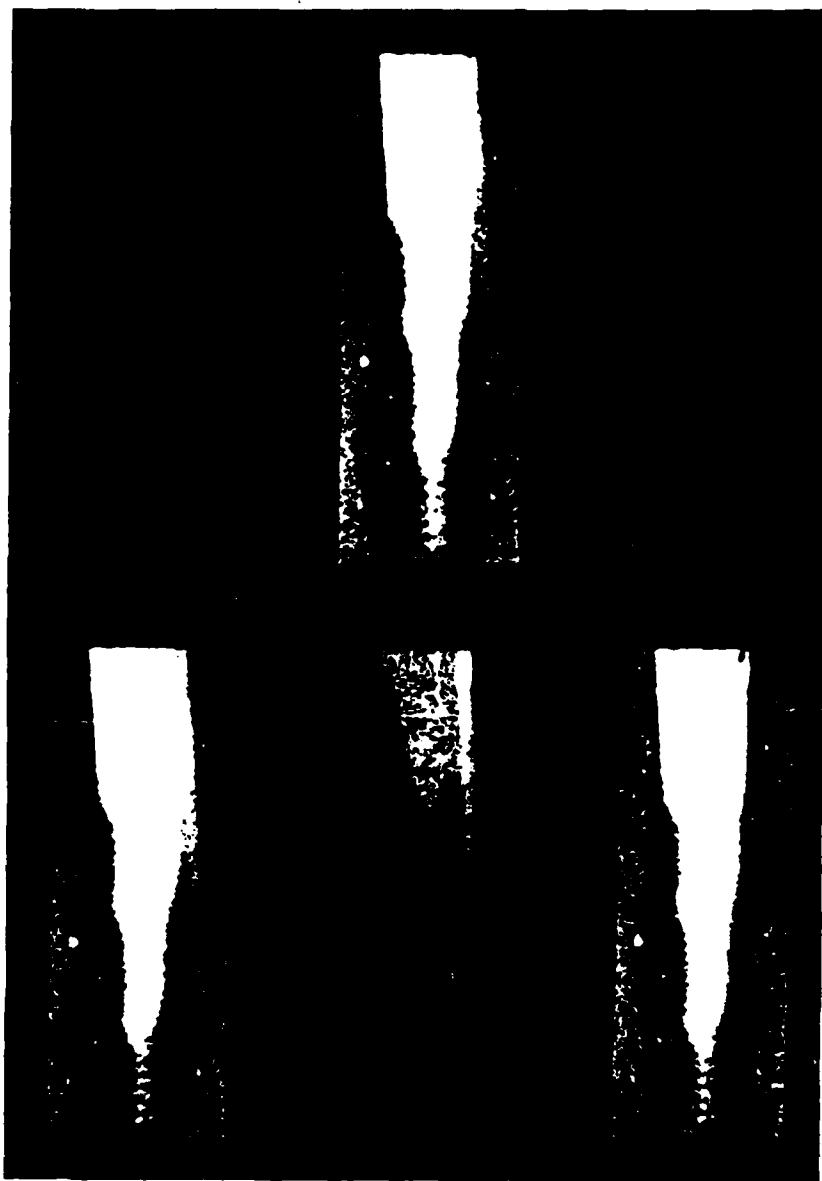

Figure 11. Computer generated images from the laser induced fluorescence (LIF) photographs.

TABLE 1. Sample comparisons of H<sub>2</sub> and D<sub>2</sub> secondary injection.

Primary <sup>a</sup>		Secondary <sup>a</sup>		P <sub>cavity</sub> <sup>b</sup> (torr)	(molecules/cm <sup>3</sup> )			Test Run	
25% F <sub>2</sub> in He	D <sub>2</sub>	D <sub>2</sub> or H <sub>2</sub>	He		Trip <sup>a</sup> N <sub>2</sub> F <sub>4</sub>	N <sub>2</sub> (A)	NF(a <sup>1</sup> Δ)		NF(b <sup>1</sup> )
0.156	0.0063	0.011 H <sub>2</sub>	0.025	0.25	9.4	9.3x10 <sup>9</sup>	2.0x10 <sup>15</sup>	2.4x10 <sup>12</sup>	24-10
0.151	0.0066	0.020 D <sub>2</sub>	0.025	0.25	10.3	5.8x10 <sup>10</sup>	4.0x10 <sup>15</sup>	1.5x10 <sup>12</sup>	25-5
0.156	0.0063	0.013 H <sub>2</sub>	0	0.25	9.4	1.1x10 <sup>10</sup>	6.7x10 <sup>15</sup>	3.3x10 <sup>12</sup>	24-9
0.154	0.0078	0.021 D <sub>2</sub>	0	0.26	13.7	1.6x10 <sup>10</sup>	9.6x10 <sup>10</sup>	1.4x10 <sup>12</sup>	26-4

<sup>a</sup>All flow rates are in g/s.<sup>b</sup>Torr = 1.33 x 10<sup>2</sup> Pa.

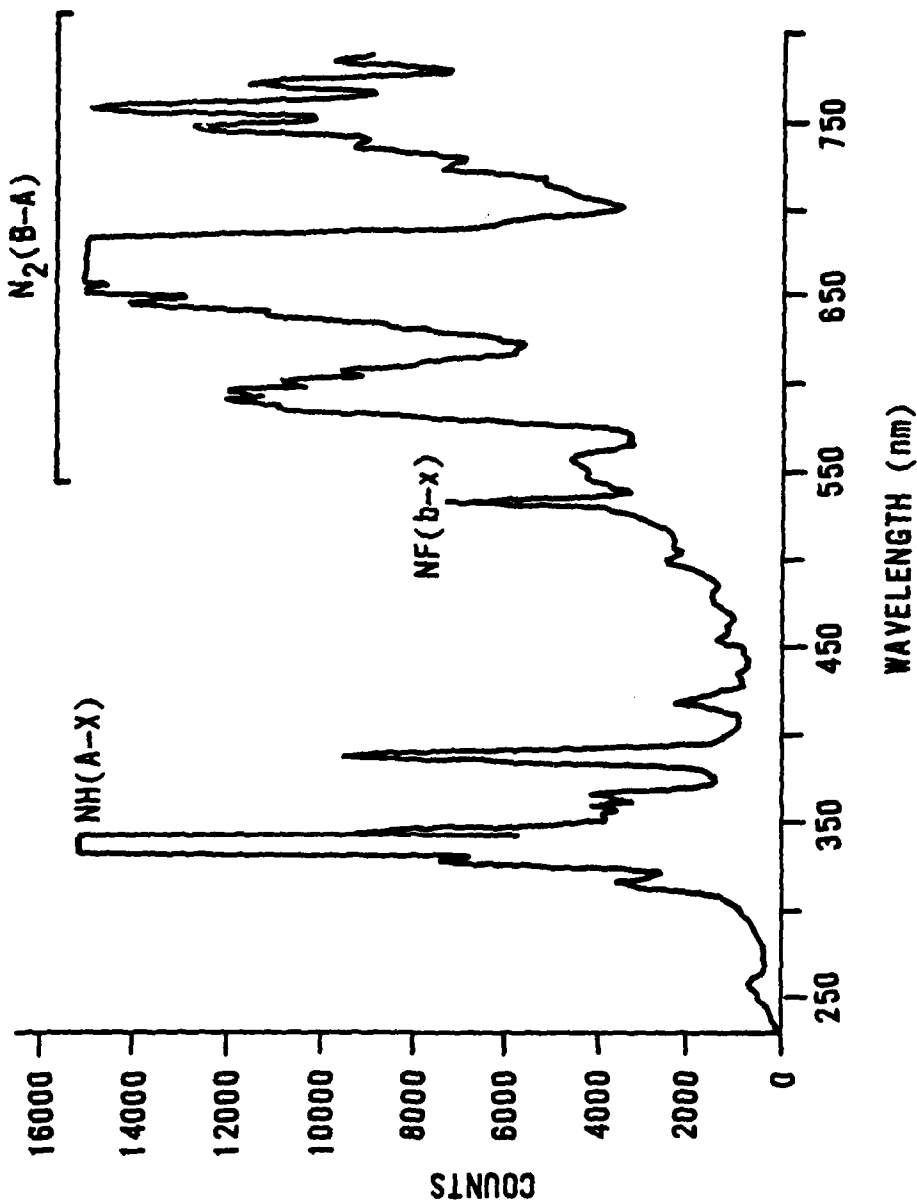

Figure 12. OMA III spectrum.

detected in the scans on the device was the 0-0 transition at 1050 nm. Population attributed to the 0-0 peak was only 1.3 percent of the total population in the 450-850 nm transitions levels. Therefore, it was concluded that the use of the visible emission to determine the  $N_2(B)$  total population was a credible method. Scans in the UV were used to determine if the  $N_2(C)$  population indicated the same  $N_2(A)$  concentration as the  $N_2(B)$  emission.  $N_2(A)$  was looked for directly as well. The NO(A-X) emission swamped all efforts to observe  $N_2(A)$  directly. Two  $N_2(C)$  peaks were identified in the 310 to 320 nm region. These are indicated in Fig. 13, which shows a trace of one of the UV scans.

Calculating the population from the  $N_2(C)$  2-1 and 1-0 peaks and assuming the vibrational distribution is known (Ref. 11), the total  $N_2(C)$  population is estimated to be  $6 \times 10^5$  molecules/cc. This yields a  $N_2(A)$  concentration of  $2.4 \times 10^{11}$  molecules/cc by employing the rate for Equation 7 since

$$[N_2(A)] = \left( [N_2(C)] / k_p \tau_C \right)^{\frac{1}{2}} \quad (8)$$

where  $k_p$  is the pooling rate, and  $\tau_C$  is the radiative lifetime of the  $N_2(C)$  state ( $\tau_C = 3.99 \times 10^{-8}$  s). This result compared well with the  $N_2(B)$  emission of  $1.6 \times 10^{11}$  molecules/cc for the same test. With the assumptions made regarding vibrational distribution of  $N_2(C)$  population, the only confirmation required is that of order of magnitude; this was accomplished. It is, therefore, accurate to determine the  $N_2(A)$  population based upon  $N_2(B)$  visible emission in the apparatus and flow conditions used in these experiments.

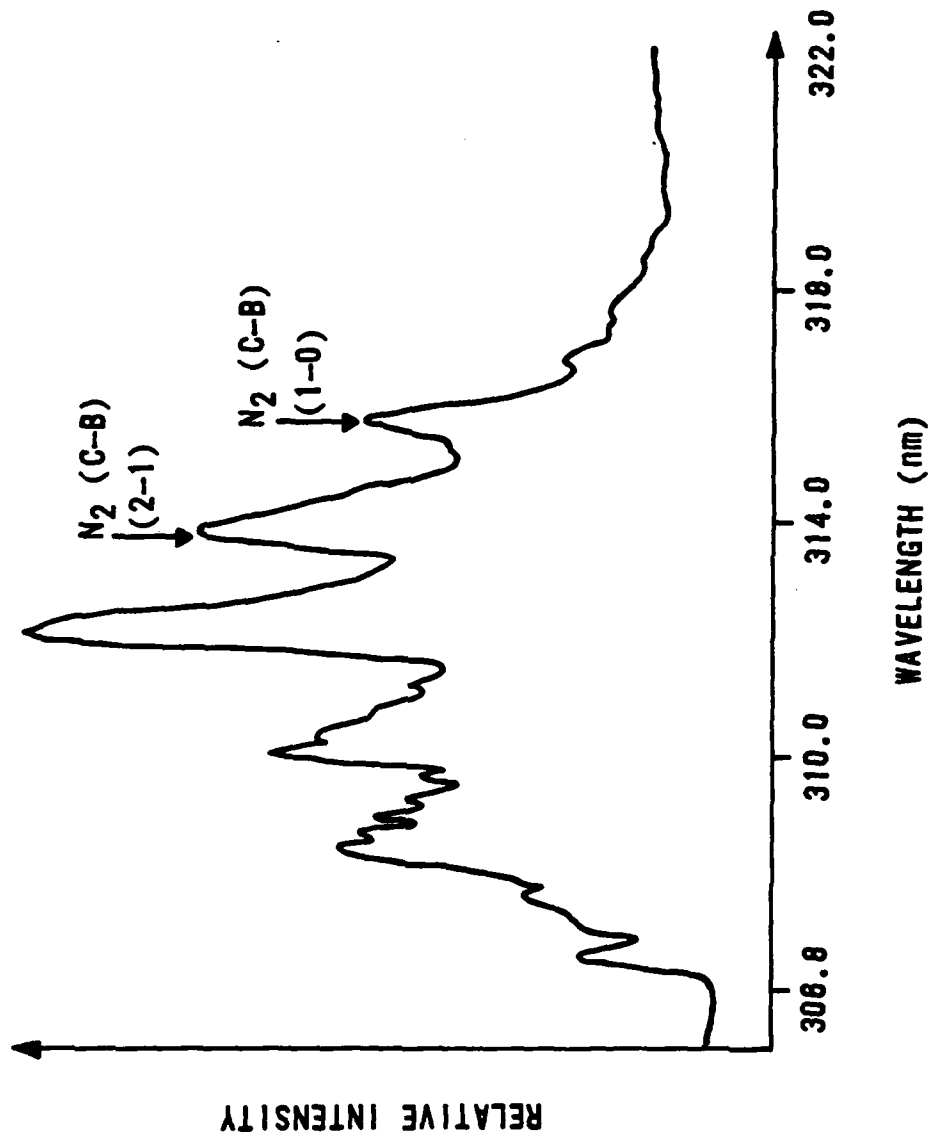
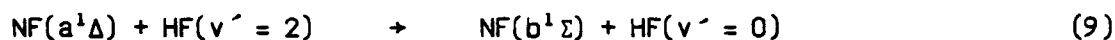

Figure 13. N<sub>2</sub>(C) spectrum.

## 8.0 CONCLUSIONS

The maximum  $N_2(A)$  yield obtained through parametric variation was  $1 \times 10^{-3}\%$  based upon initial  $N_2F_4$ . This corresponded to a concentration of  $\sim 2 \times 10^{11}$  molecules/cc, using  $D_2$  in the secondary jets. Similar flow rates using  $H_2$  yielded a 5 to 10 times smaller concentration of  $N_2(A)$ . The increase with  $D_2$  may be because of the inability of DF to react with  $NF(a^1\Delta)^{13}$  as HF does in the following reactions



$$k = 8.3 \times 10^{-12} \text{ cc/molecule-s}$$

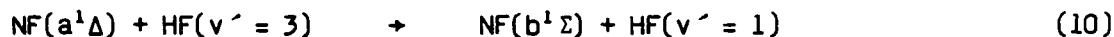

$$k = 7.5 \times 10^{-11} \text{ cc/molecule-s}$$

Therefore, by using  $D_2$  in the reaction sequence the  $NF(b^1\Sigma)$  formation from  $NF(a^1\Delta)$  is minimized. This provides additional  $NF(a^1\Delta)$  for further reaction to form  $N_2(A)$ . This was checked by comparing the tests with  $H_2$  and tests with  $D_2$ . Table 2 contains the flow rate and diagnostic data on these tests. There is a decrease in  $NF(b^1\Sigma)$  population as noted by Herbelin and Cohen (Ref. 12). However, the decrease in  $NF(b^1\Sigma)$  is insufficient to account for the increase in  $NF(a^1\Delta)$  and thus  $N_2(A)$ . The conclusion is that there is increased jet penetration at similar molar flow rates if  $H_2$  and  $D_2$  because of the higher molecular weight of  $D_2$ . The  $N_2(A)$  production is then aided by better mixing. The decrease in  $NF(b)$  most probably aides  $N_2(A)$  but to a lesser degree. The overall conclusion is that  $D_2$  should be used as the secondary gas instead of  $H_2$ . A small number of tests were attempted using trip jet injection of  $D_2$  and secondary jet injection of  $N_2F_4$ . The result was lower  $N_2(B)$  emission at the same flow rates and reversed injection.

TABLE 2. SAMPLE HIGH  $[N_2(B)]$  TESTS

25% $F_2^a$ in $He^2$	$D_2^a$ Combustor	$D_2^a$ Secondary	$He^a$ Secondary	$N_2F_4^a$	$P_{cavity}$ (Torr) <sup>c</sup>	$N_2(B)$ (molecule/ cc)
0.167 <sup>b</sup>	0.0095	0.02	----	0.26	12.2	$1.6 \times 10^{11}$
0.152	0.0066	0.02	0.024	0.25	10.4	$1.1 \times 10^{11}$
0.155	0.0077	0.02	0.085	0.26	13.4	$1.3 \times 10^{11}$

<sup>a</sup> All flows are in g/s

<sup>b</sup> This test used 35 percent  $F_2$  in He

<sup>c</sup> Torr =  $1.33 \times 10^2$  Pa ( $Nm^{-2}$ )

## 9.0 RECOMMENDATIONS

Further nozzle development is needed to improve mixing. The BCL-16 type nozzle is insufficient for this reaction scheme. It is recommended here that a new nozzle be designed to deal with the very heavy  $\text{NF}_2$  and extremely light  $\text{D}_2$  penetration problems.

The other question remaining is - what is the actual branching ratio for  $\text{NF}(a^1\Delta)$  production given by Equation 3. The measurement needs to be made precisely. Previous assumptions of a 90 percent branching ratio were based upon an indirect measurement (Ref. 10). Current research should be directed towards better defining the branching ratio.

Since the pooling rate for  $\text{N}_2(A)$  is rapid, there will be a limit to the  $[\text{N}_2(A)]$  which is achievable. Therefore, it is important to find an energy transfer acceptor which may be premixed with the  $\text{NF}_2$  or injected early in the reaction sequence. The difficulty lies in finding an acceptor atom or molecule which does not seriously impact the  $\text{N}_2(A)$  production scheme.

Overall,  $\text{N}_2\text{F}_4 + \text{D}_2$  reaction scheme for  $\text{N}_2(A)$  production holds promise although difficulties have been determined. A program to adequately address these problems may allow for successful use of this scheme for a chemical transfer laser.

## REFERENCES

1. Kolts, J.H., Brashears, H.C., and Setser, D.W., J. Chem. Phys., 67, 2931 (1977).
2. Young, R.A. and St. John, G.A., J. Chem. Phys., 48, 895 (1968).
3. Cheah, C.T., Clyne, M.A.A., and Whitefield, P.D., J. C. S. Faraday II, 76, 711 (1980).
4. Tregay, G.W., et al., DF/HF Chemical Laser Technology, Bell Aerospace Textron Report No. D9276-9270003, Bell Aerospace Textron, Buffalo, New York, January 1981.
5. Jones, Y. D., et al., NF(a<sup>1</sup>Δ) Production in a Supersonic Flow Using N<sub>2</sub>F<sub>4</sub> + H<sub>2</sub> in a BCL-16 Nozzle, AFWL-TR-87-24, Kirtland AFB, New Mexico, January 1988.
6. Rapagnani, N.L. and Davis, S.J., AIAA Journal, 17, 1402 (1979).
7. Jones, Y.D., An Absolute Scanning NF(a<sup>1</sup>Δ) and NF(b<sup>1</sup>Σ) Diagnostic for the N<sub>2</sub>F<sub>4</sub> + H<sub>2</sub> System, AFWL-TR-86-99, Kirtland AFB, New Mexico, July 1987.
8. Hays, G.N. and Oskam, H.J., J. Chem. Phys., 59, 6088 (1973).
9. Khakoo, M.A. and Srivastave, S.K., J. Quant Spectrosc. Radiat. Transfer, 30, 31 (1983).
10. Malins, R.J. and Setser, D.W., J. Phys Chem., 85, 1342 (1981).
11. Lofthus, A. and Krupenie, P.H., J. Phys and Chem Ref. Data, 6, 113 (1977).
12. Herbelin, J.M. and Cohen, N., Chem Phys. Lett., 20, 605, (1973).

APPENDIX  
REACTIONS IN THE  $\text{NF}_2 + \text{H}$  PRODUCTION OF  $\text{N}_2(\text{A}^3\Sigma_g^-)$

TABLE 1A.

PRINCIPLE REACTIONS AND KNOWN RATES  
(All rates are in cc/molecule - s)

1.	$\text{NF}_2 + \text{H} \rightarrow \text{NF}(a^1\Delta) + \text{HF}(v'=0,1,2,3)$	
	$k_{v'=0} = 9.56 \times 10^{-12}; k_{v'=1} = 3.97 \times 10^{-12}; k_{v'=2} =$	
	$1.03 \times 10^{-12}; k_{v'=3} = 1.47 \times 10^{-13}$	Ref. 1,2
2.	$\text{NF}_2 + \text{H} \rightarrow \text{NF}(b^1\Sigma) + \text{HF}(v'=0)$	
	$k_2 = 2.94 \times 10^{-13}$	Ref. 2
3.	$\text{NF}(a^1\Delta) + \text{H} \rightarrow \text{N}(^2\text{D}) + \text{HF}(v'=0,1,2)$	
	$k_3 = 2.5 \times 10^{-13}$	Ref. 3
4.	$\text{NF}(a^1\Delta) + \text{N}(^2\text{D}) \rightarrow \text{N}_2(\text{B}) + \text{F}$	
	$k_4 = 3.0 \times 10^{-11}$	Ref. 4
5.	$\text{NF}(a^1\Delta) + \text{HF}(v=2,3) \rightarrow \text{NF}(b^1\Sigma) + \text{HF}(v'=0,1)$	
	$k_{v'=2} = 8.3 \times 10^{-12}; k_{v'=3} = 7.5 \times 10^{-11}$	Ref. 5
6.	$\text{NF}(a^1\Delta) + \text{M} \rightarrow \text{NF}(X^3\Sigma) + \text{M}$	
	$k_6 = 1.7 \times 10^{-13}$	Ref. 6
7.	$\text{NF}(b^1\Sigma) + \text{M} \rightarrow \text{NF}(a^1\Delta) + \text{M}$	
	$k_7 = 5.0 \times 10^{-12}$	Ref. 6
8.	$\text{NF}(b^1\Sigma) + \text{M} \rightarrow \text{NF}(X^3\Sigma) + \text{M}$	
	$k_8 = 5.0 \times 10^{-12}$	Ref. 6
9.	$\text{N}(^2\text{D}) + \text{N}_2(^1\Sigma) \rightarrow \text{N}(^4\text{S}) + \text{N}_2(\text{X})$	
	$k_9 = 1.0 \times 10^{-14}$	Ref. 7
10.	$\text{N}(^2\text{D}) + \text{N}(^4\text{S}) \rightarrow 2\text{N}(^4\text{S})$	
	$k_{10} = 1.0 \times 10^{-14}$	estimated
11.	$2\text{NF}(X^3\Sigma) \rightarrow \text{N}_2(\text{X}) + 2\text{F}$	
	$k_{11} = 7 \times 10^{-11}$	Ref. 1
12.	$\text{NF}(a^1\Delta) + \text{NF}(X^3\Sigma) \rightarrow \text{N}_2(\text{X}) + 2\text{F}$	
	$k_{12} = 7 \times 10^{-11}$	Ref. 1



$$k_{13} = 1.1 \times 10^{-9}$$

Ref. 8

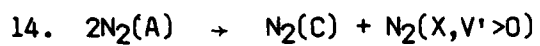

$$k_{14} = 2.6 \times 10^{-10}$$

Ref. 9

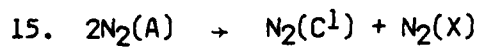

$$k_{15} = 2.6 \times 10^{-11}$$

Ref. 8

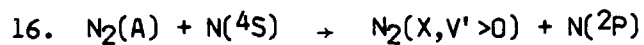

$$k_{16} = 3.5 \times 10^{-11}$$

Ref. 10

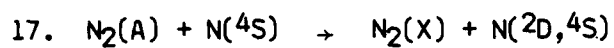

$$k_{17} = 3.5 \times 10^{-11}$$

Ref. 10

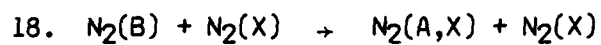

$$k_{18} = 2.7 \times 10^{-11}$$

Ref. 11

## REFERENCES

1. Cheah, C.T., Clyne, M.A.A. and Whitefield, P.D., J. C. S. Faraday II, 76, 711 (1980).
2. Malins, R.J. and Setser, D.W., J. Phys. Chem., 85, 1342 (1981).
3. Cheah, C.T. and Clyne, M.A.A., J. Photochem, 15, 21 (1981).
4. Cheah, C.T. and Clyne, M.A.A., J. C. S. Faraday II, 76, 1543 (1980).
5. Herbelin, J.M., Dwok, M.A. and Cohen, N., Modeling of the H + NF<sub>2</sub> Reactive Flow, 5D-TR-81-21, The Aerospace Corporation, El Segundo, California, April 1981.
6. Kwok, M.A., Herbelin, J.M. and Cohen, N., Collisional Quenching and Radiative Decay Studies of NF(a<sup>1</sup>Δ) and NF(b<sup>1</sup>Σ<sup>+</sup>), SAMS0-TR-77-73, The Aerospace Corporation, El Segundo, California, April 1977.
7. Lin, C.L. and Kaufman, F., J. Chem. Phys., 55, 3760 (1971).
8. Hays, G.N. and Oskam, H.J., J. Chem. Phys., 59, 1507 (1973).
9. Hays, G.N. and Oskam, H.J., J. Chem. Phys., 59, 6088 (1973).
10. Vedaud, P.H., Wayne, R.P., Yaron, M. and von Engel, A., J. C. S. Faraday Trans II, 73, 1185 (1976).
11. Young, R.A., Black, G. and Slinger, T.G., J. Chem Phys, 50, 303 (1969).

END

DATE

FILMED

8-88

DTIC