

AD-A194 613

IMPROVEMENTS IN TECHNIQUES OF MICROWAVE THERMOGRAPHY
(U) MASSACHUSETTS INST OF TECH CAMBRIDGE RESEARCH LAB
OF ELECTRONICS A H BARRETT FEB 88 DAMD17-83-C-3025

1/1

UNCLASSIFIED

F/G 6/5

NL



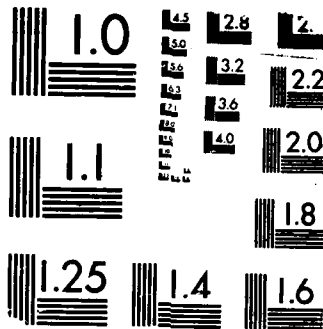

MICROCOPY RESOLUTION TEST CHART
NBS 1963-A

AD _____

Improvements in Techniques of Microwave Thermography

Final Scientific Report

November 15, 1982 - June 30, 1985

Alan H. Barrett

February 1988

Supported by

U. S. ARMY MEDICAL RESEARCH AND DEVELOPMENT COMMAND
Fort Detrick, Frederick, Maryland 21701-5012

Contract No. DAMD17-83-C-3025

Research Laboratory of Electronics
MASSACHUSETTS INSTITUTE OF TECHNOLOGY
Cambridge, Massachusetts 02139

DOD DISTRIBUTION STATEMENT
Approved for public release; distribution unlimited

DTIC
ELECTE
JUN 17 1988
S D
E

The findings in this report are not to be construed as an official Department of the Army position unless so designated by other authorized documents.

AD-A194 613

UNCLASSIFIED

SECURITY CLASSIFICATION OF THIS PAGE

REPORT DOCUMENTATION PAGE

Form Approved
OMB No. 0704-0188

1a. REPORT SECURITY CLASSIFICATION Unclassified		1b. RESTRICTIVE MARKINGS	
2a. SECURITY CLASSIFICATION AUTHORITY		3. DISTRIBUTION / AVAILABILITY OF REPORT Approved for public release; distribution unlimited	
2b. DECLASSIFICATION / DOWNGRADING SCHEDULE		5. MONITORING ORGANIZATION REPORT NUMBER(S)	
4. PERFORMING ORGANIZATION REPORT NUMBER(S)		7a. NAME OF MONITORING ORGANIZATION	
6a. NAME OF PERFORMING ORGANIZATION Research Laboratory of Electronics Massachusetts Institute of Technology	6b. OFFICE SYMBOL (If applicable)	7b. ADDRESS (City, State, and ZIP Code)	
6c. ADDRESS (City, State, and ZIP Code) 77 Massachusetts Avenue Cambridge, MA 02139		9. PROCUREMENT INSTRUMENT IDENTIFICATION NUMBER DAMD17-83-C-3025	
8a. NAME OF FUNDING / SPONSORING ORGANIZATION US Army Medical Research and Development Command	8b. OFFICE SYMBOL (If applicable)	10. SOURCE OF FUNDING NUMBERS	
8c. ADDRESS (City, State, and ZIP Code) Fort Detrick Frederick, Maryland 21701-5012		PROGRAM ELEMENT NO. 61102A	PROJECT NO. 3MI- 61102BS10
		TASK NO. CE	WORK UNIT ACCESSION NO. 114
11. TITLE (Include Security Classification) Improvements in Techniques of Microwave Thermography			
12. PERSONAL AUTHOR(S) Alan H. Barrett			
13a. TYPE OF REPORT Final	13b. TIME COVERED FROM 11/15/82 TO 6/30/85	14. DATE OF REPORT (Year, Month, Day) 1988 February	15. PAGE COUNT 18
16. SUPPLEMENTARY NOTATION			
17. COSATI CODES		18. SUBJECT TERMS (Continue on reverse if necessary and identify by block number)	
FIELD	GROUP	Radiation, Thermography, Radiometry, Microwave Thermography,	
06	03		
06	13		
19. ABSTRACT (Continue on reverse if necessary and identify by block number)			
<p>This Final Scientific Report covers the period from 15 November 1982 to 30 June 1985. During this period ^{of} our research efforts were concentrated in the following areas: (1) The development and testing of a reflection-compensating radiometer. (2) A theoretical investigation of the variation of microwave penetration depth in human tissue as a function of the aperture size of the contact antenna. (3) Antenna design to give improved penetration depth. (4) A study of the utility of bistatic measurements to detect embedded tumors and aid microwave thermography and hyperthermia. This report is subdivided into these four main sections. <i>Keywords: -</i></p>			
20. DISTRIBUTION / AVAILABILITY OF ABSTRACT <input checked="" type="checkbox"/> UNCLASSIFIED/UNLIMITED <input type="checkbox"/> SAME AS RPT. <input type="checkbox"/> DTIC USERS		21. ABSTRACT SECURITY CLASSIFICATION Unclassified	
22a. NAME OF RESPONSIBLE INDIVIDUAL Virginia M. Miller		22b. TELEPHONE (Include Area Code) 301/663-7325	22c. OFFICE SYMBOL SGRD-RMI-S

SUMMARY

This Final Scientific Report covers the period from 15 November 1982 to 30 June 1985. During this period our research efforts were concentrated in the following areas: (1) The development and testing of a reflection-compensating radiometer. (2) A theoretical investigation of the variation of microwave penetration depth in human tissue as a function of the aperture size of the contact antenna. (3) Antenna design to give improved penetration depth. (4) A study of the utility of bistatic measurements to detect embedded tumors and aid microwave thermography and hyperthermia. This report is subdivided into these four main sections.

Accession For	
NTIS GRA&I	<input checked="" type="checkbox"/>
DTIC TAB	<input type="checkbox"/>
Unannounced	<input type="checkbox"/>
Justification	
By _____	
Distribution/	
Availability Codes	
Dist	Avail and/or Special
A-1	



TABLE OF CONTENTS

	Page
List of Illustrations	4
Body of Report	5
Distribution List	18

LIST OF ILLUSTRATIONS

<u>Figure Number</u>	<u>Title</u>	<u>Page</u>
Figure 1.	Block diagram of radiometer	6
Figure 2.	Reflection-compensating radiometer	7
Figure 3.	Effect of reflections on compensating and non-compensating radiometer	9
Figure 4.	Penetration depth in breast tissue as a function of aperture size	11
Figure 5.	Near-field measurements of horn patterns in breast material	14
Figure 6.	H-plane scan in simulated fat at 2 cm depth	15
Figure 7.	Bistatic scattering measurement set-up	16

BODY OF THE REPORT

Reflection-Compensating Radiometer

Microwave thermography measures the brightness temperature of a human subject but the clinician desires a knowledge of the physical temperature. Since the brightness temperature is the product of the emissivity and the physical temperature, it is important to develop a system which simultaneously measures both the emissivity and brightness temperature so that the physical temperature may be accurately determined. In turn, the emissivity ϵ is related to the reflection coefficient ρ , a quantity more easily measured, by the simple relation $\epsilon = (1-\rho)$.

We have developed a radiometer, operating at 1.4 GHz, capable of determining both the tissue temperature and the emissivity of the tissue. Designs for such reflection-compensating radiometers have been proposed by several groups and we initially followed their designs closely. Basically two measurements must be made to determine both the temperature and emissivity and this is accomplished by measuring (1) the emission from the subject and (2) the emission from the subject plus the reflected power from the subject when a small amount of power is directed at the subject. A block diagram of the final system is shown in Figure 1. The system is calibrated by taking two measurements with the calibration switch on the short, one with the noise tube on and one with the noise tube off. Two measurements are then made with the calibration switch on the antenna, again one with the noise tube on and one with the noise tube off. These data are then used to compute the reflection coefficient and the microwave temperature incident on the antenna as shown in Figure 2. The calibration and measurement procedures are controlled by the microprocessor, which also controls the Dicke switch, and the results are displayed on a video terminal.

The system differs from many previously proposed in that it operates in an unbalanced mode at all times. Other systems have incorporated a servo loop to drive one of the observed signals to zero. We found this inconvenient

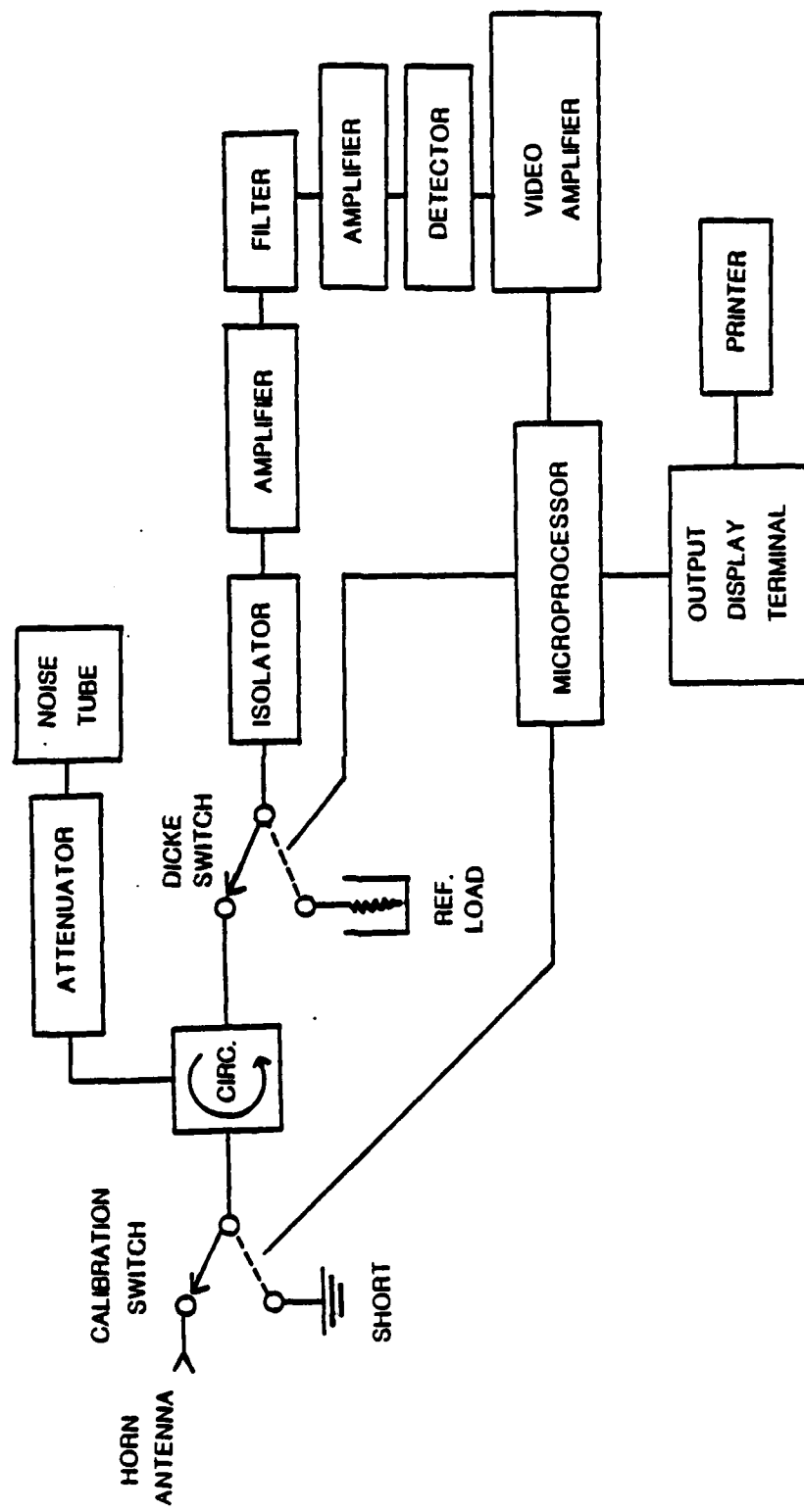
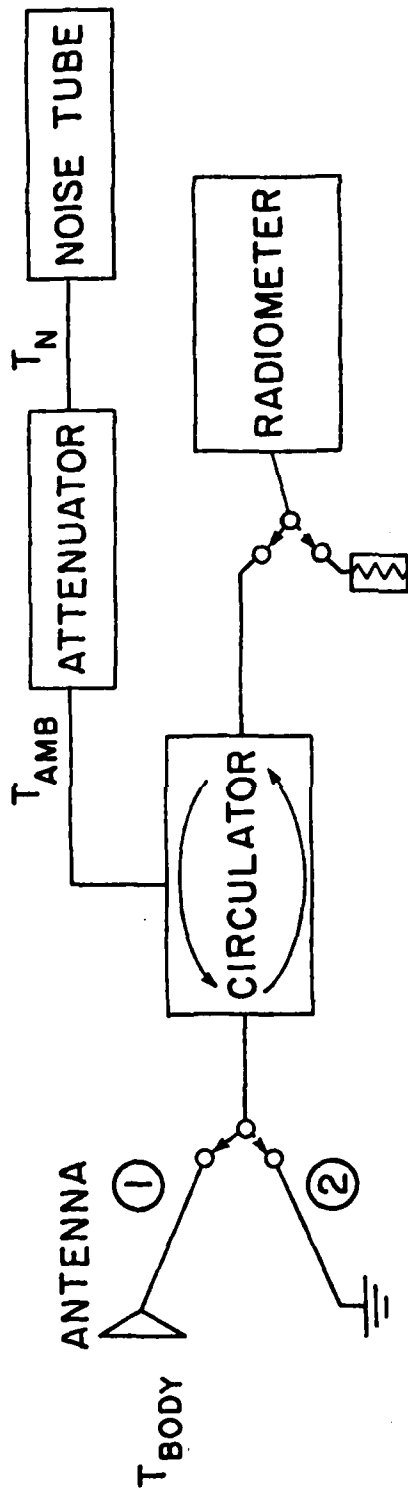

Figure 1

REFLECTION COMPENSATING RADIOMETER



ΔT 'S ARE MEASURED RADIOMETRIC READINGS

$$\rho = (\Delta T_A - \Delta T_B) / (\Delta T_C - \Delta T_D)$$

$$T_{\text{BODY}} = [(\Delta T_A - \Delta T_B) / (1 - \rho)] + T_{\text{AMB}}$$

NOISE TUBE SWITCH POSITION

ΔT_A	ON	1
ΔT_B	OFF	1
ΔT_C	ON	2
ΔT_D	OFF	2

Figure 2

because of the minimum step available with a motor-driven attenuator and the time delay in making an observation as the attenuator was driven toward balance. Our present radiometer has sufficient gain stability that operation in an unbalanced mode is not detrimental.

We subsequently modified our standard Dicke radiometers, operating at 3 and 6 GHz to conform to our reflection-compensating design.

A minor modification was made to the radiometers which has been helpful in improving the overall repeatability of the radiometers. The microprocessor computes the reflection coefficient and the microwave temperature incident on the antenna. The physical temperature of the circulator enters into this computation and it had been our practice to use a nominal value for this temperature for all times. However, when looking at various heated dummy loads, either matched or mismatched, at an elevated temperature, the radiometer consistently computed a temperature differing from the true temperature by 1-2 C. This difference varied slowly during the day and is believed to have resulted from temperature changes of the circulator, due to variations in the ambient temperature and heating of the circulator by other components of the radiometer. We incorporated a temperature sensor on the circulator so that its temperature is read during each observation and used in each calculation of the reflection coefficient and microwave temperature. This has resulted in a significant reduction in the drift of the radiometer with time.

The ability of a reflection-compensating radiometer to correct for the effects of an impedance mismatch at the antenna-tissue interface is shown in Figure 3. For a multi-purpose radiometer used for microwave thermography, reflection compensation is vital because of the varying dielectric properties of tissue, fat, and muscle in different parts of the body.

Aperture Size and Penetration Depth

Many investigators of microwave thermography have utilized open-end

EFFECTS OF REFLECTIONS ON COMPENSATING AND NON-COMPENSATING RADIOMETER

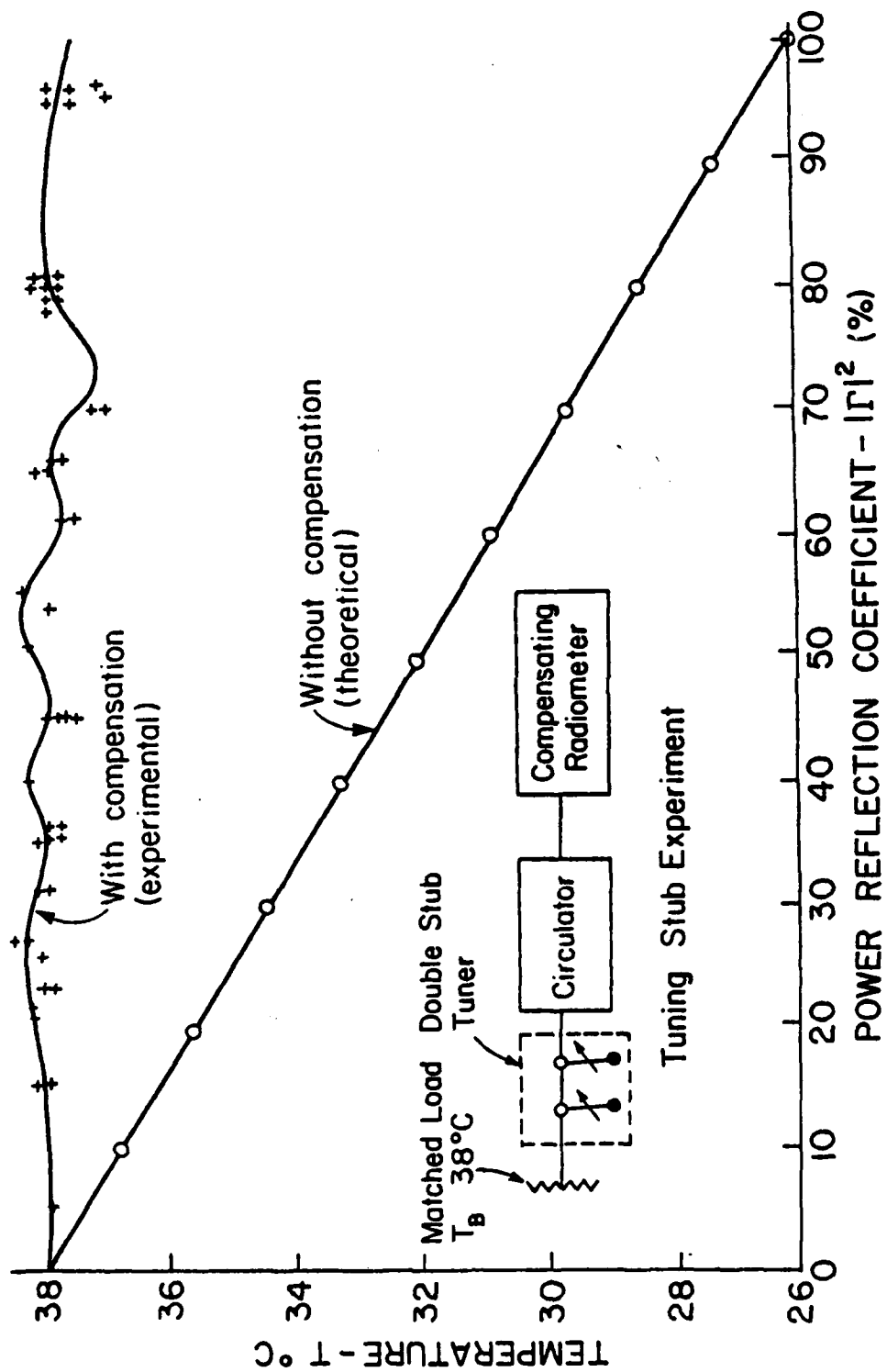

Figure 3

dielectric-filled, waveguides as the antenna, coupling the body emission to the radiometer. Since the penetration depth is greater for longer wavelengths most thermographic studies have been done in the 1-6 GHz range. However, this relatively low frequency range requires unduly large waveguide apertures thereby destroying spatial resolution. By filling the guide with a dielectric one effectively decreases the wavelength in the medium and permits the propagation of 1-6 GHz radiation in a waveguide of reduced dimensions. Furthermore, the impedance match of the antenna to the body, necessary for optimum power transfer, is improved by the addition of the dielectric.

However, estimates of the penetration depth using the usual plane wave formula are overly optimistic and in need of drastic revision when applied to a waveguide aperture in direct contact with human tissue. The reason is not difficult to envision. The plane wave case is applicable only when the distance from the aperture to the subject is large so that waves emanating from the aperture may be approximated as plane waves at the subject. This is clearly not the case when the antenna aperture is in contact with the subject.

Even the definition of penetration depth is not applicable for contact antennas because the electromagnetic fields do not fall off exponentially with increasing distance from the aperture until the far-field (plane wave) region is reached. Nevertheless, one can define the penetration depth as the distance where the power is e^{-1} or 0.368 (4.34 db) of the value at the surface. This distance will depend on the angle with respect to the axis of the aperture because the surface of constant power is not spherical.

In Figure 4 we show the results of our calculations of the on-axis penetration depth as a function of aperture size, measured in wavelengths in the medium, for several frequencies commonly used in microwave thermography. The calculations assumed a skin thickness of 1.5 mm overlying breast tissue and that only the TE_{10} mode was excited in the antenna even though the dimensions were large enough to permit other modes to propagate. Similar computations for a single aperture size have been done by others and their conclusion, like ours, is that the penetration depth strongly depends on the characteristics of the antenna and that plane wave penetration depth grossly overestimates the actual case unless the aperture dimensions exceed one

PENETRATION DEPTH IN BREAST TISSUE
AS A FUNCTION OF APERTURE SIZE

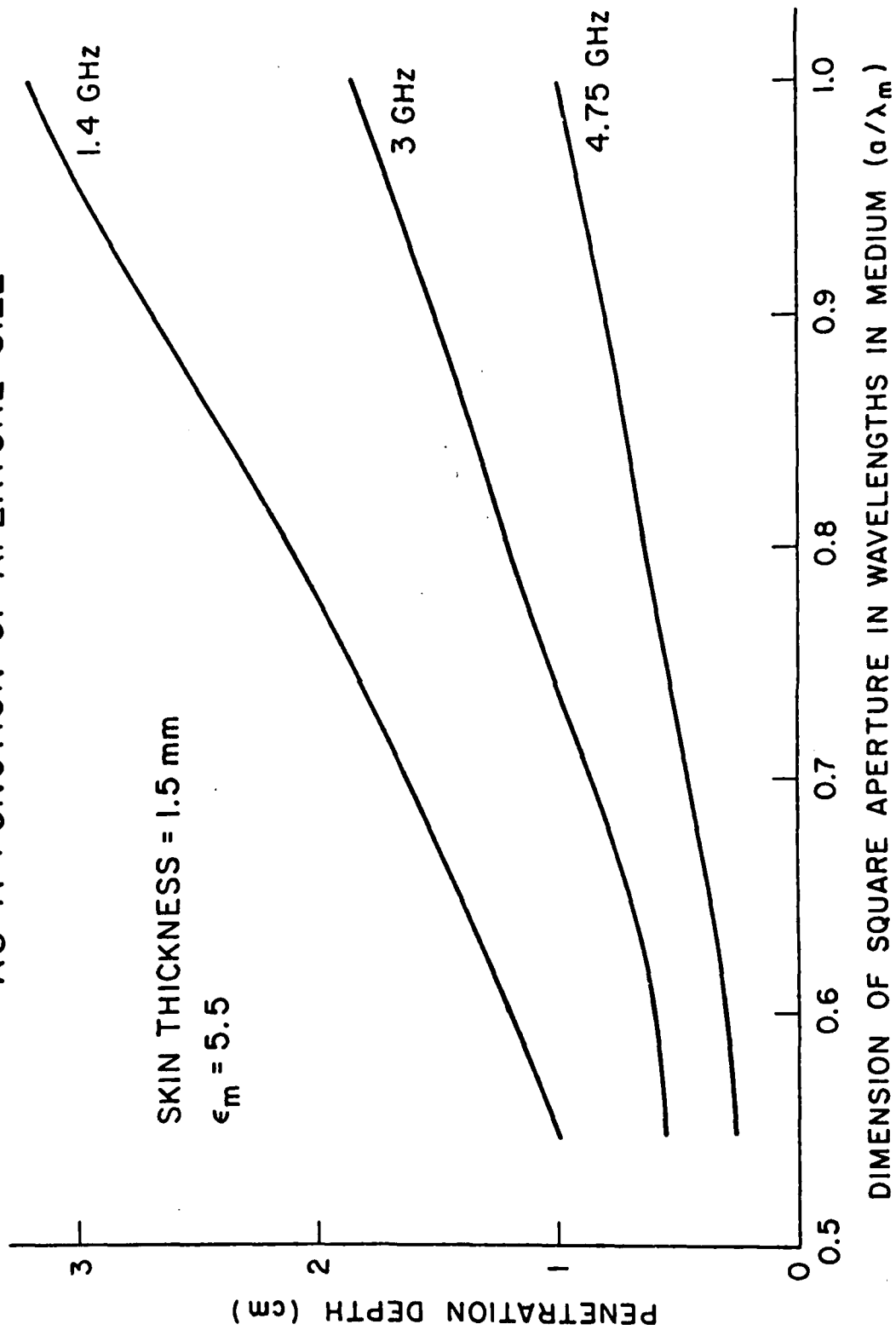

Figure 4

wavelength or the tissue being examined is very lossy, i.e. high in water content. For example, the plane wave penetration depth would be at least two times the values given in Figure 4 for $a/\lambda_m = 1$. Thus one sees how the penetration depth is seriously compromised for aperture dimension less than a wavelength in size.

Antenna Design

Utilization of a reflection-compensating radiometer for microwave thermography has an important implication for the design of antennas used in thermography. In the past, antennas have been designed using dielectric-filled waveguides with the dielectric constant chosen to provide a good match to body tissue. Typical dielectric constants have been about 5. This has permitted propagation in waveguides $\sqrt{5}$ times smaller in linear dimensions than would otherwise be possible for the same frequency. With the advent of reflection-compensating radiometers, however, the need for good impedance match at the antenna-tissue interface is alleviated, to a large degree. This is because the radiometer corrects for the mismatch by computing the reflection coefficient and using it in the computation of the microwave temperature. This has made the design and fabrication of the antennas considerably simpler, and therefore, cheaper. Furthermore, it has allowed one to use rather large, air-filled antennas without the complication of higher-order waveguide modes, as would occur with the same size antenna filled with a dielectric. The importance of being able to use larger air-filled waveguides is that the aperture size, measured in terms of wavelengths in tissue, approaches or exceeds one wavelength and leads to improved penetration depth. It should be pointed out that the use of large-aperture antennas leads to a loss of angular resolution, but this should not be detrimental when the antennas are used in a correlation interferometer because the angular resolution is determined to a large degree by the linear separation of the antennas. Under these circumstances the antennas should be optimized for depth penetration at the expense of lateral resolution.

The above results have been borne out by experimental measurements

using a Zener diode noise source, slabs of dielectric material which simulate tissue, and our reflection-compensating radiometer at 3 GHz. The Zener diode noise source is powered by a DC voltage through short resistive leads to reduce scattering from the leads. It is a convenient noise source, although uncalibrated as a thermal source, stable and easily variable by adjusting the DC voltage. For relative measurements, such as antenna power patterns or penetration depth measurements, it has been very satisfactory. The experimental set-up for our near-field measurements is shown in Figure 5 and some results for various antennas are shown in Figure 6. The dielectric constants of the material in the waveguide antennas A, B, and C is 1.0, 4.0, and 8.0, respectively. Note, antenna A is an air-filled antenna.

Bistatic Measurements

The potential application of interferometric techniques to microwave thermography is of interest because it will significantly improve the angular resolution and could provide medical personnel with a thermal image of the area surveyed.

In preparation for experiments related to correlation interferometry we made bistatic measurements with one antenna driven by a noise tube or a signal generator, a second antenna attached to the reflection-compensating radiometer, and with a scattering object in the field-of-view of both antennas beneath layers of simulated tissue. The signal input to the radiometer was composed of the direct coupling between the two antennas plus the coherent signal scattered off the spherical (or cylindrical) object in the common field of view. As the antennas are scanned across the scattering object, only the component of the signal from the scatterer varies. In this manner we found we can easily detect variations in dielectric constant at depths of 5 cm or more. The resulting signal, because of the coherence, is the vector sum of the directly coupled electric field plus that from the scatterer. This technique may be of importance in the localization of tumors to be subjected to hyperthermia. The experimental set-up for our bistatic measurements is shown in Figure 7.

NEAR FIELD MEASUREMENTS OF HORN PATTERNS IN BREAST MATERIAL

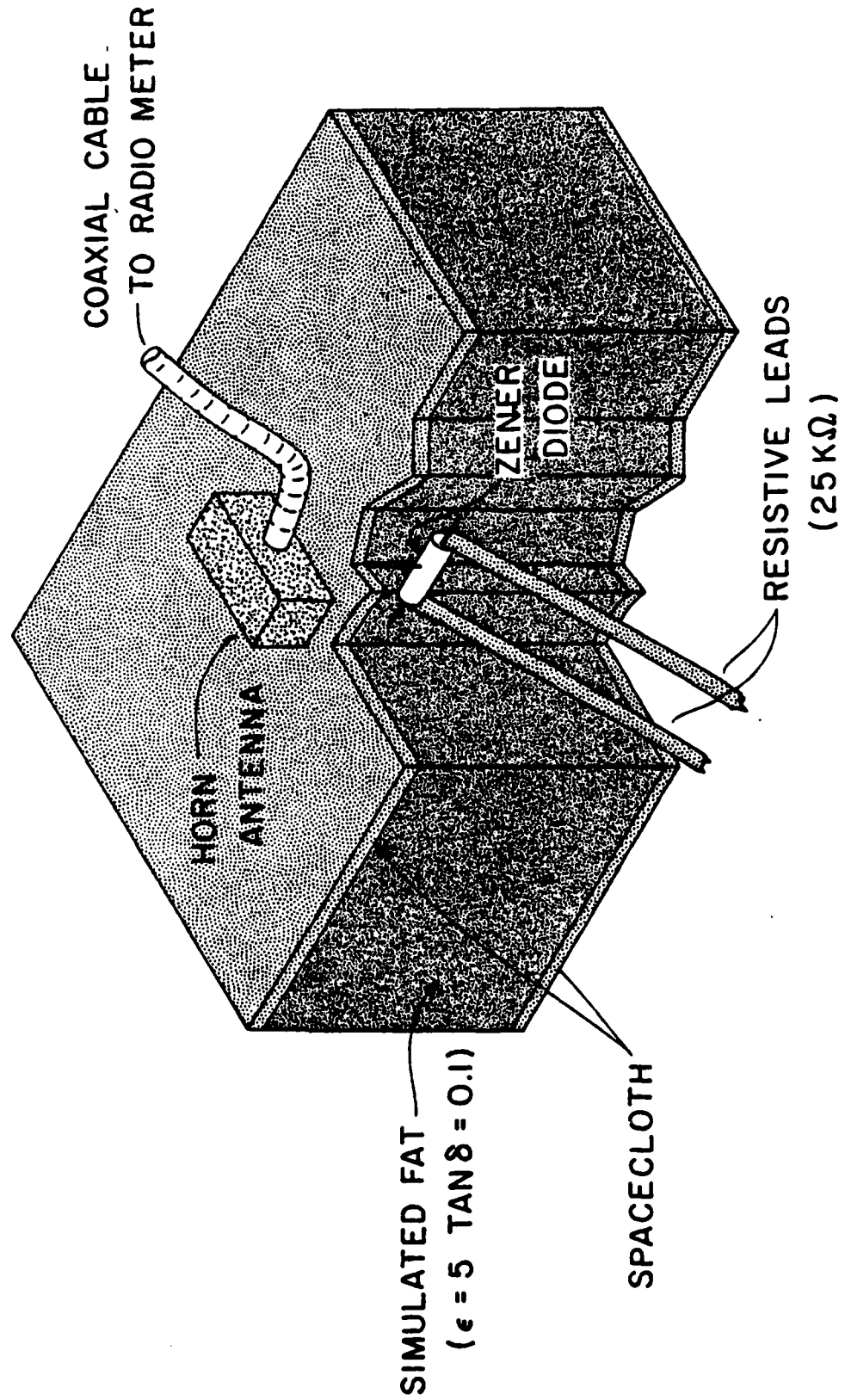

Figure 5

H PLANE SCAN IN SIMULATED FAT AT A 2cm DEPTH

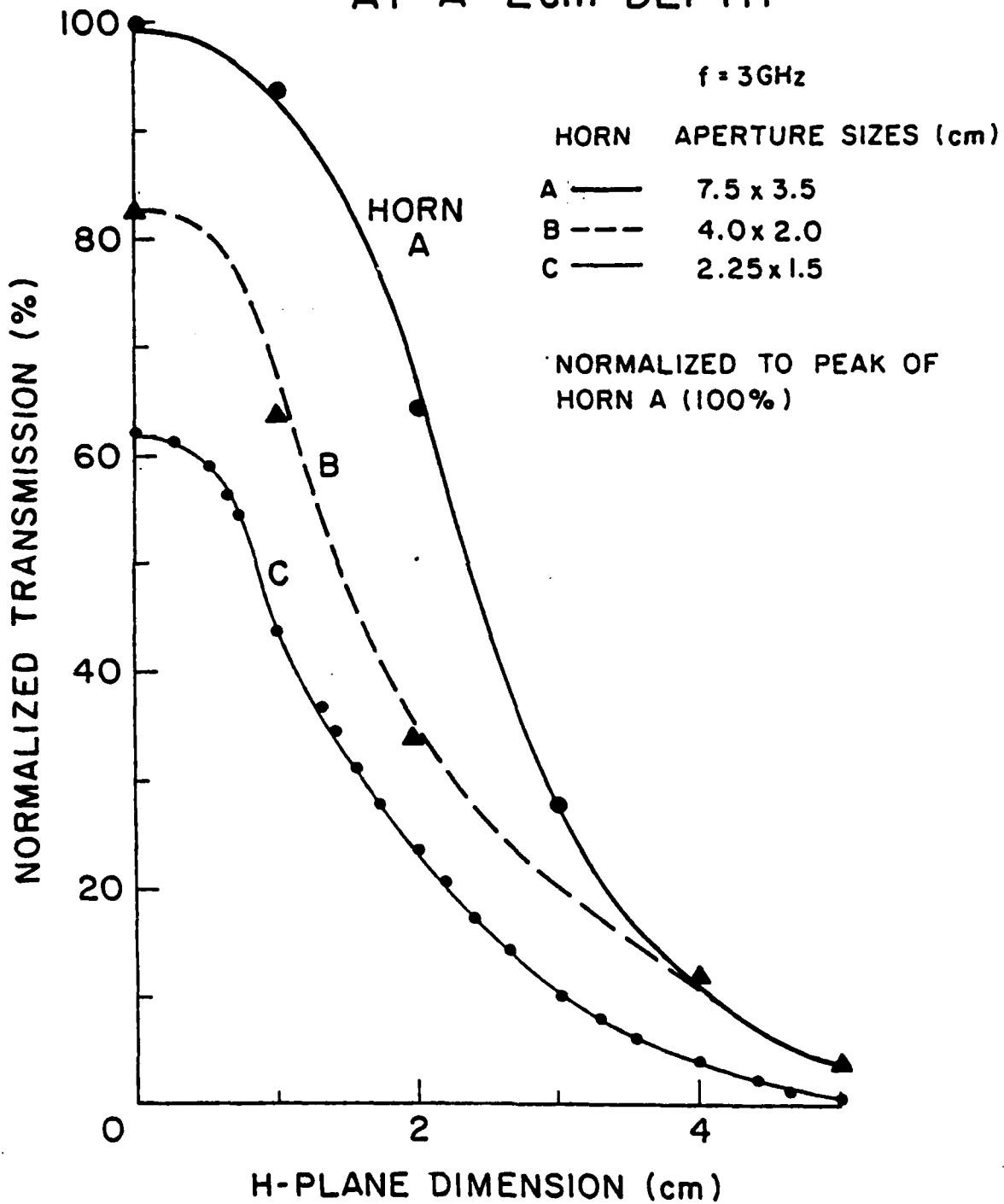

Figure 6

BISTATIC SCATTERING MEASUREMENT SET-UP

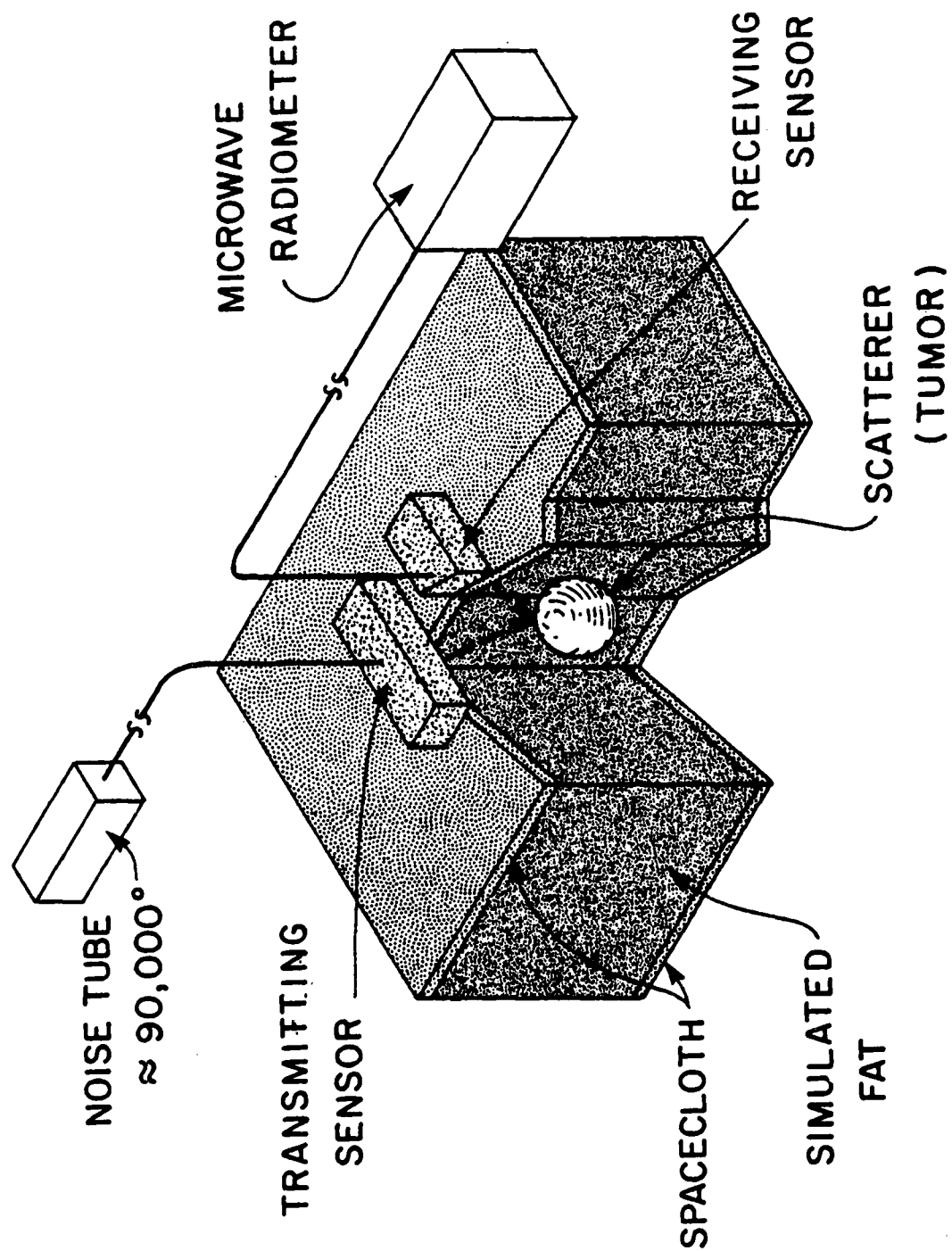

Figure 7

Bistatic scattering experiments represent an extension of microwave thermography which requires minor hardware additions but offers the potential of providing significant information about tumor size and the proper frequency for hyperthermia. Since tumors have different dielectric properties than the tissue medium in which they are imbedded their presence can be revealed by backscattering measurements. Furthermore, since the tumor will have a characteristic size the variation of the backscatter with frequency will provide information on their size since the radiation scattered in the backward direction will depend on the ratio of the characteristic size to the wavelength in the medium, λ_m . This can be shown most clearly by considering the scattering from dielectric spheres. If the radius of the sphere is r then the backscatter cross section varies as a r^4 when $r/\lambda_m < 0.1$. As r/λ_m increases, the cross section undergoes a series of resonances before approaching the value predicted by geometrical optics. The wavelengths at which the resonances occur can give a measure of the radius.

The scattering from dielectric particles has been studied theoretically and experimentally since the work of Mie, Deby, and Rayleigh in the early 1900's. This work has assumed lossless particles, spherical shape, plane wave illumination of the particle, and observation of the scattered radiation in the far-field of the particle. None of these assumptions are applicable to our investigations. Nevertheless, our observations appear to show characteristic resonances in the scattering cross section which are related to d/λ_m , where d is a measure of the size of the scatterer.

If the difference in dielectric constant between a tumor and the surrounding regions is large then resonances can also occur in the absorption of electromagnetic radiation by the tumor. This fact provides a means to optimize the frequency to be used for electromagnetic-induced hyperthermia. It may then be possible to heat the tumor specifically without a detrimental heating of the entire surrounding medium. Furthermore, by reciprocity, a resonance in absorption implies a resonance in emission, a fact which has not been exploited in microwave thermography.

DISTRIBUTION LIST

12 copies: Director
 Walter Reed Army Institute of Research
 Attn: SGRD-UWZ-C
 Walter Reed Medical Center
 Washington, D. C. 20307-5100

1 copy: Commander
 US Army Medical Research and Development
 Command
 Attn: SGRD-RMI-S
 Fort Detrick, Frederick, Maryland 21701-5012

12 copies: Administrator
 Defense Technical Information Center
 Attn: DTIC-DDAC
 Cameron Station Alexandria, Virginia 22304-6145

1 copy: Commandant
 Academy of Health Sciences, US Army
 Attn: AHS-CDM
 Fort Sam Houston, Texas 78234-6100

1 copy: Dean, School of Medicine
 Uniformed Services University
 of the Health Sciences
 4301 Jones Bridge Road
 Bethesda, MD 20814-4799

END

DATE

FILMED

8-88

DTIC