

AD-A194 650

UNSTEADY FLOW PAST AN NACA 0012 AIRFOIL AT HIGH ANGLES
OF ATTACK (U) FLORIDA AGRICULTURAL AND MECHANICAL UNIV
TALLAHASSEE FLUID ME A KROTHAPALLI ET AL 02 MAR 88
FMRL-TR-2 AFOSR-TR-88-0415

1/1

UNCLASSIFIED

F/G 1/3

NL



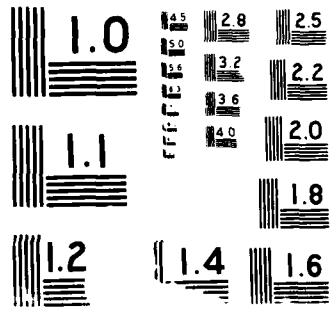

SECURITY CLASSIFICATION OF THIS PAGE

~~UNCLASSIFIED~~

REPORT DOCUMENTATION PAGE

DTIC FILE CODE

1a. REPORT SECURITY CLASSIFICATION		1b. RESTRICTIVE MARKINGS	
2a. SECURITY CLASSIFICATION AUTHORITY		3. DISTRIBUTION/AVAILABILITY OF REPORT	
2b. DECLASSIFICATION/DOWNGRADING SCHEDULE		Approved for public release, distribution unlimited	
4. PERFORMING ORGANIZATION REPORT NUMBER(S) FMRL TR-2		5. MONITORING ORGANIZATION REPORT NUMBER(S) AFOSR-TR-88-0415	
6a. NAME OF PERFORMING ORGANIZATION Department of Mechanical Engineering FAMU/FSU College of Engineering	6b. OFFICE SYMBOL (If applicable)	7a. NAME OF MONITORING ORGANIZATION AFOSR/NA Bolling AFB, DC 20338	
6c. ADDRESS (City, State, and ZIP Code) P. O. Box 2175 Tallahassee, FL 32316-2175		7b. ADDRESS (City, State, and ZIP Code) AFOSR/NA Bolling AFB, DC 20338	
8a. NAME OF FUNDING/SPONSORING ORGANIZATION AirForce Office of Scientific Research	8b. OFFICE SYMBOL (If applicable) NA	9. PROCUREMENT INSTRUMENT IDENTIFICATION NUMBER AFOSR-86-0243	
8c. ADDRESS (City, State, and ZIP Code) Building 410 Bolling AFB, D.C. 20332-6448		10. SOURCE OF FUNDING NUMBERS	
		PROGRAM ELEMENT NO. 61102F	TASK NO. A3
11. TITLE (Include Security Classification) Unsteady Flow Past a NACA 0012 Airfoil at High Angles of Attack			
12. PERSONAL AUTHOR(S) A. Krothapalli, L. Lourenco and L. van Dommelen			
13a. TYPE OF REPORT Annual	13b. TIME COVERED FROM 07/86 TO 12/87	14. DATE OF REPORT (Year, Month, Day) 1988, March 2	15. PAGE COUNT 25
16. SUPPLEMENTARY NOTATION			
17. COSATI CODES		18. SUBJECT TERMS (Continue on reverse if necessary and identify by block number)	
FIELD	GROUP	Unsteady Aerodynamics, Vortex Dynamics; fluid dynamics	
19. ABSTRACT (Continue on reverse if necessary and identify by block number)			
<p>→ A whole field experimental technique, commonly referred to as Particle Image Displacement Velocimetry, was used for the measurement of the instantaneous two-dimensional velocity fields about an impulsively started NACA 0012 airfoil at high angles of attack. The velocity field was measured with sufficient accuracy, such that the time evolution of the vorticity field was obtained. The experiments were performed in a towing tank at a Reynolds number of 1400, based on the chord of the airfoil. For angles of attack greater than about 20°, the flow field at the upper surface of the airfoil show large scale vortical motions with the following time dependent scenario. At the initial stages of the airfoil startup, a separation bubble at the leading edge was generated and with time, it grows into an isolated primary vortex which dominated the whole flow field. Trailing behind this primary vortex were two counter rotating vortices. This multiple vortex structure grow together and move along the upper surface until it reaches the trailing edge. At this time, the primary vortex induces a trailing edge vortex. The primary and trailing edge vortices then form the wake flow field. However, when the airfoil has a finite aspect ratio, which is the case in this study, the primary vortex, at some intermediate time, abruptly moves away from the upper surface leaving behind a "free shear layer" like flow structure. The flow eventually becomes highly three-dimensional. It is suggested that such a phenomenon occurs due to the interaction of the tip vortices with the primary vortex causing it to move away from the upper surface.</p> <p>A parallel computational study was conducted using a random-walk vortex simulation of the full two-dimensional Navier-Stokes equations. Except for the effects of the tip vortices, the experimental and numerical results show similar features.</p>			
20. DISTRIBUTION/AVAILABILITY OF ABSTRACT		21. ABSTRACT SECURITY CLASSIFICATION	
<input type="checkbox"/> UNCLASSIFIED/UNLIMITED <input checked="" type="checkbox"/> SAME AS RPT. <input type="checkbox"/> DTIC USERS			
22a. NAME OF RESPONSIBLE INDIVIDUAL H. Helin	22b. TELEPHONE (Include Area Code) 202 767 0471	22c. OFFICE SYMBOL AFOSR/NA	

DTIC SELECTED
SERIES
WORK UNIT
ACCESSION NO.

AFOSR-TR. 88-0415

**UNSTEADY FLOW PAST AN NACA 0012 AIRFOIL
AT HIGH ANGLES OF ATTACK**

by

A. Krothapalli, L. Lourenco and
L. van Dommelen

Department of Mechanical Engineering
FAMU/FSU College of Engineering
P.O. Box 2175
Tallahassee, FL 32316-2175

Accession For	
NTIS GRA&I	<input checked="" type="checkbox"/>
DTIC TAB	<input type="checkbox"/>
Unannounced	<input type="checkbox"/>
Justification	
By _____	
Distribution/	
Availability Codes	
Dist	Avail and/or Special
A-1	



Grant no. AFOSR-86-0243

Technical Report for a Period July 1986 - December 1987

Prepared for

Air Force Office of Scientific Research
Bolling Air Force Base, Washington D.C. 20332

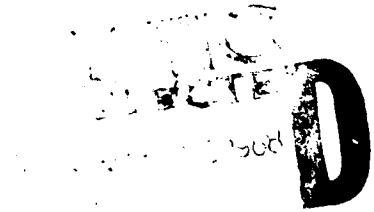

Contents

	Page no.
1. Introduction and Research Objectives	1
2. Status of the Research Effort	2
3. Publications	5
4. Professional Personnel	6
5. Presentations and Seminars	7

Introduction

A research program consisting of basic experimental studies of the fluid mechanics of an accelerating airfoil undergoing a stepwise variation in the angle of attack was initiated in July 1986 under grant no. AFOSR-86-0243. This technical report is being written to describe the work carried out during the period, July 1986 - December 1987 of the grant.

The present study has the following main objectives to the general problem of the unsteady vortical flows generated by high angle of attack airfoils.

1. Investigate experimentally the unsteady flow structure generated by a NACA airfoil at different angles of attack started impulsively from rest.
2. Investigate experimentally the transient flow characteristics of an NACA airfoil undergoing a stepwise varied angle of attack.
3. Investigate the unsteady flow structure of an accelerating NACA 0012 airfoil at different fixed angles of attack.
4. Investigate the transient flow characteristics of an accelerating airfoil undergoing a stepwise incidence variation.

As originally envisaged in all these studies, attention was directed to the basic understanding of the unsteady flow phenomena. During these investigations, a paralleled effort was devoted in consultation with AFOSR, to study some of the experimentally observed features using numerical solutions. A unique experimental technique, developed in our laboratory, is successfully implemented to study, in detail, the unsteady large scale vortical motions that occur in these flows.

In the following, the status of the research effort is given along with some of the most important conclusions arrived in this study to date.

Status of the Research Effort

In the following, major conclusions on the various facets of the research program are given.

A systematic investigation has been carried out on the structure of an unsteady flow field generated by an impulsively started NACA 0012 airfoil, of finite aspect ratio, at different angles of attack ($0 \leq \alpha \leq 45^\circ$), and at a fixed Reynolds number of 1400.

A novel experimental technique known as "Particle Image Displacement Velocimetry" was used to measure the instantaneous two dimensional velocity field. The velocity field was measured with sufficient accuracy and spatial resolution that the vorticity field and the pressure field can be computed very accurately, a unique capability of this technique. The detailed description of this technique is given in Appendix I.

A parallel computational study was conducted to augment the above mentioned experimental studies. This effort was supported by the Mechanical Engineering Department. In this study, the performance of the discrete vortex, random walk approximation to the Navier-Stokes equations was examined for the case of large scale separation flow about an impulsively started NACA 0012 airfoil at different angles of attack. The primary objective was to include sufficient vortices to resolve the shortest meaningful length scales of the flow at a given computational time step. The new fast velocity summation algorithm* enables the flow to be computed with much more resolution than previously possible in vortex methods.

The main features of the unsteady large scale separated flow about an impulsively started airfoil are as follows:

The multiple exposed photographs of the flow field about the airfoil at 10° or less incidence showed that the flow is well behaved and attached to the airfoil over the entire period of observation. However, at large angles of attack $\alpha \geq 20^\circ$, the flow separates on the upper surface of the airfoil and generates large scale vortices. The following scenario develops in time on the upper surface of the airfoil. At the start of the airfoil, a vortex, at the trailing edge, commonly designated as "starting vortex" is generated and carried away from the airfoil. Concomitant with this is the generation of a separation bubble at the leading edge of the airfoil. At a later time, the separation bubble grows into an isolated

* van Dommelen, Leon, and Rundensteiner, Elke A., "Fast, Adaptive Summation of Point Forces in the Two-Dimensional Poisson Equation." Submitted to the *Journal of Computational Physics*.

primary vortex with secondary vortices following behind it. This multiple vortex structure continues to grow together and move along the upper surface until it reaches the trailing edge. At this point, the primary vortex induces a vortex at the trailing edge. Finally, the primary vortex and the induced trailing edge vortex interact and generate a complex flow field. However, for finite aspect ratio airfoils or wings, a different type of flow field seems to emerge at later stages of development. The various events described above occur at different times, depending upon the angle of attack and Reynolds number.

Typical PIDV measurements of the instantaneous velocity field, at different times, for an airfoil $\alpha = 30^\circ$ are shown in figure 1. The aspect ratio of the wing was about 3. The airfoil travels from right to left. The data is presented in a body fixed reference frame. The length of the velocity vector corresponds to its magnitude. The dimensionless time t^* is defined as $\frac{tU}{C}$ where U is the free stream velocity and C is the airfoil chord. The starting vortex (at the far right of the picture) and the initial separation bubble at the leading edge can be seen clearly in the picture corresponding to $t^* = 0.68$.⁶ The primary vortex with secondary vortices following behind it can be seen in the figure at $t^* = 2.02$. The trailing edge vortex can be seen in the figure at $t^* = 3.02$. At $t^* > 3$, the primary vortex abruptly moves away from the upper surface leaving behind a "vortex sheet-" like structure. Such a behavior is attributed to the inference of tip vortices which are generated due to the finite aspect ratio of the airfoil. At later times, for example at $t^* = 4.85$, the tip vortices interact with the separated flow on the upper surface and generate a complicated three-dimensional flow field. The nature of this interaction and the parameters that govern such a flow field is not known yet.

Typical two-dimensional computational results from random-walk vortex simulations of the full Navier-Stokes equations are shown in figure 2. The angle of attack and the Reynolds number are the same as those in the experiment; the results of which are shown in figure 1. The streamline pattern, along with vorticity, which is represented in bit-mapped graphics as half tones are shown in the figure. Except for the effect of the finite aspect ratio of the airfoil,, the stream line pattern looks very much similar to those observed in figure 1. To further evaluate these results, the locus of the primary vortex as it develops in time is shown in figure 3. The computational results agree well with the experiment for $t^* \leq 2$. Beyond $t^* = 2$, it is expected that the experimental flow field was influenced by the tip vortices making it to be highly three-dimensional. The coefficients of lift and drag as obtained from the computations are shown in figure 4. As expected, the coefficient of lift increases with t^* up to a point where the primary vortex is attached to the upper surface. For later times, where the primary vortex leaves the upper surface, the coefficient

of lift drops significantly.

Results similar to these described above were obtained at $\alpha = 10^\circ$, 20° and 45° . The details of this work will be given in a paper to be submitted to the AIAA Journal.

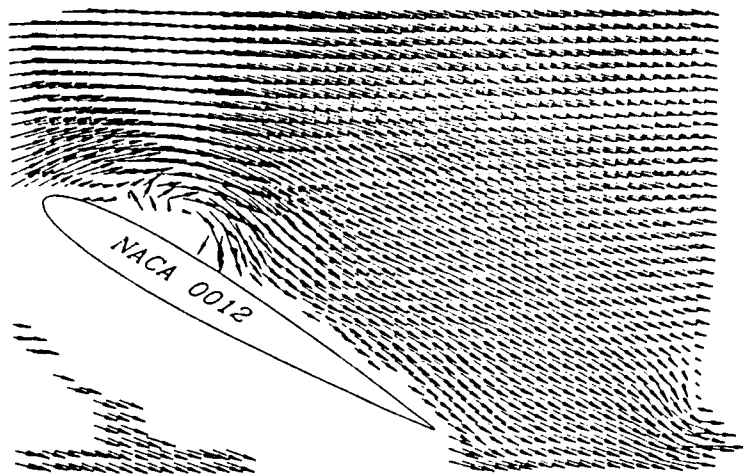

$t^* = 0.68$

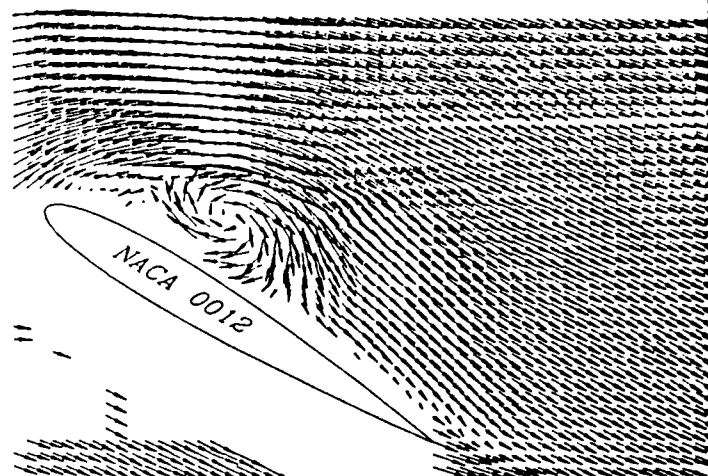

$t^* = 1.02$

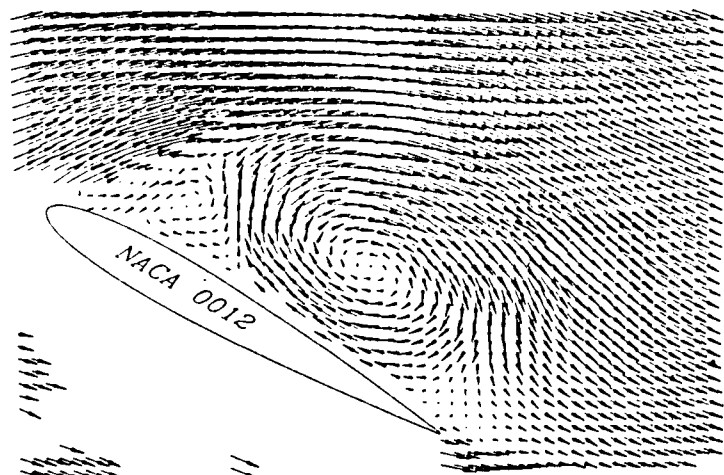

$t^* = 2.02$

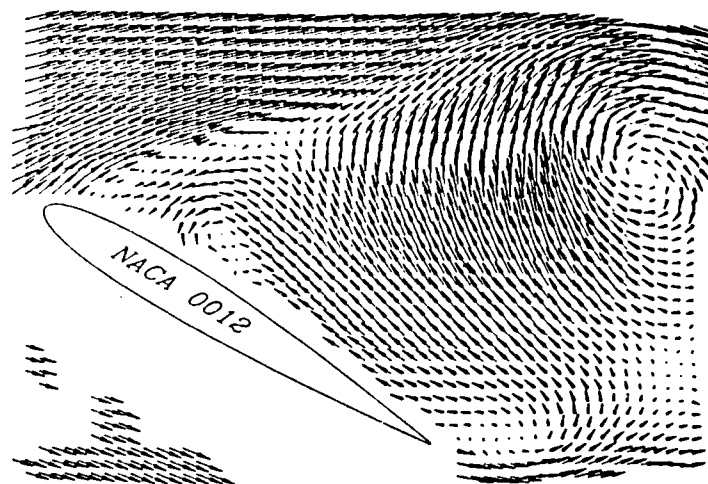

$t^* = 3.02$

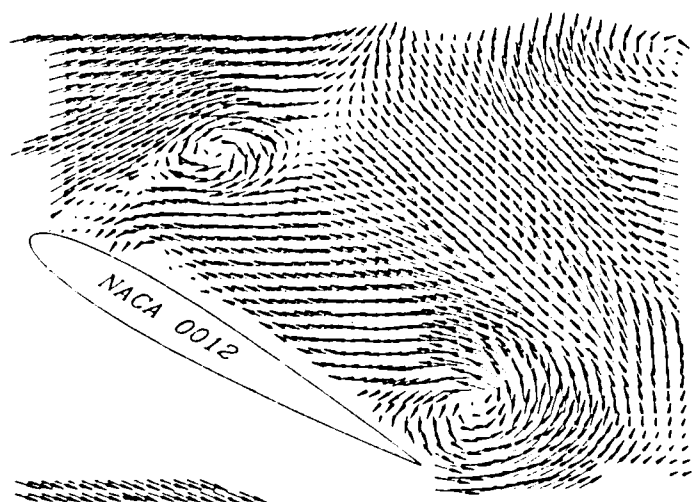

$t^* = 4.02$

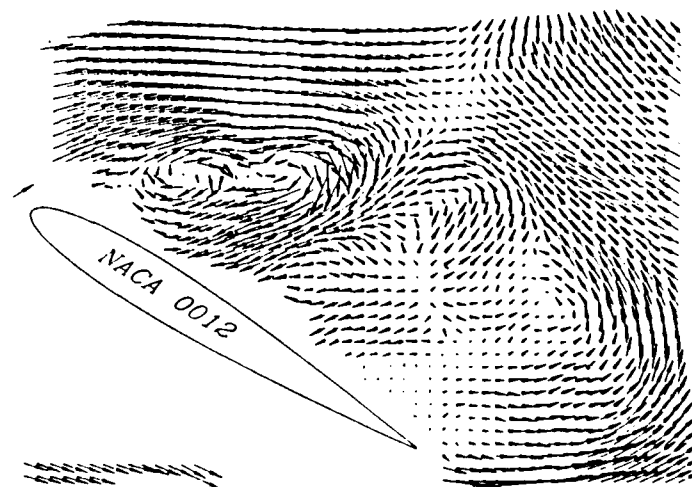

$t^* = 4.85$

Figure 1. Time evolution of the instantaneous velocity field in the central plane of the wing obtained using PIDV. $Re = 1400$. angle of attack = 30 degrees.

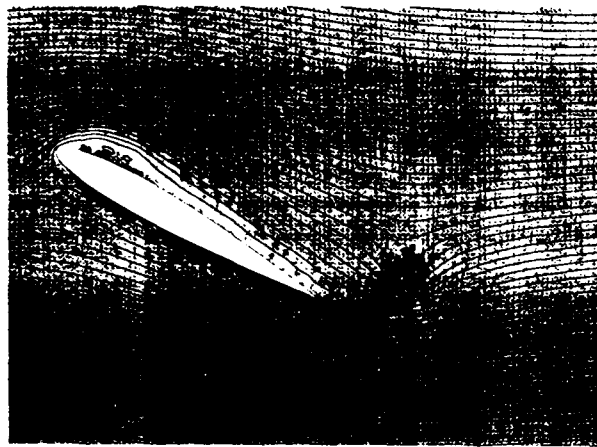

$t^* = 0.5$

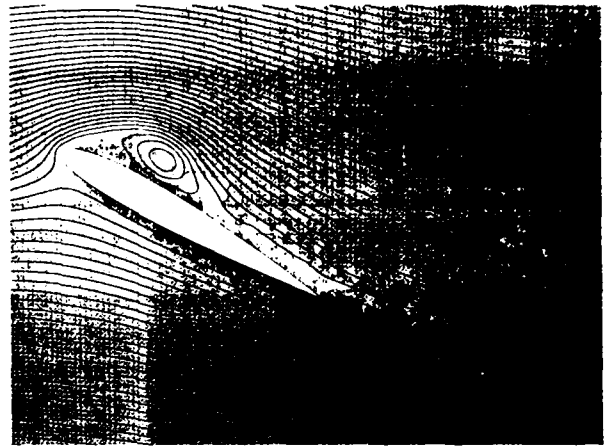

$t^* = 1.0$

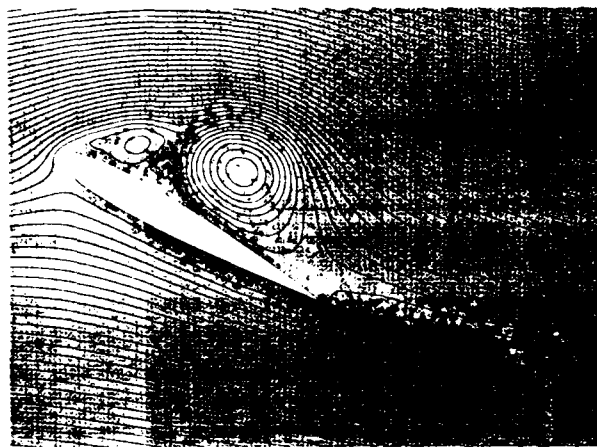

$t^* = 2.0$

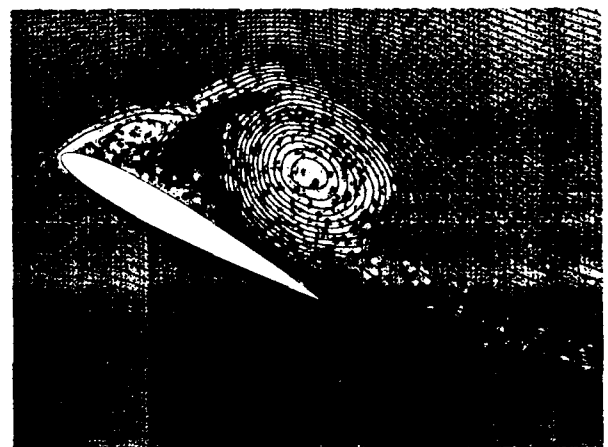

$t^* = 3.0$

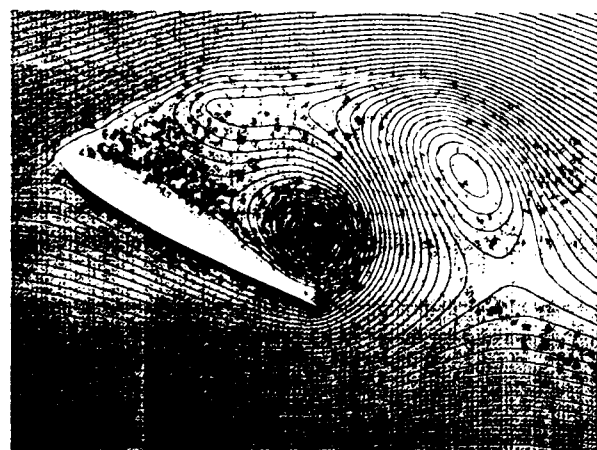

$t^* = 4.0$

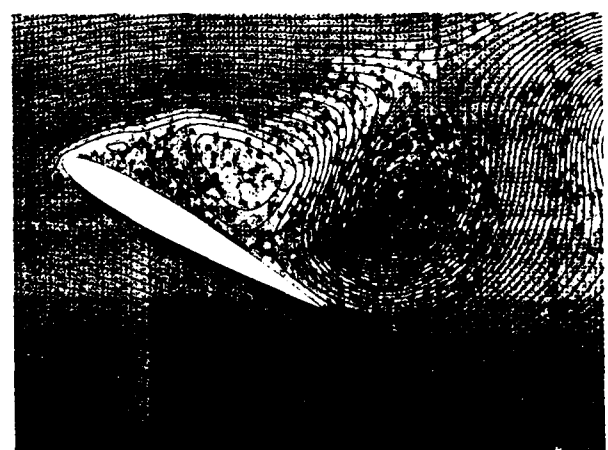

$t^* = 5.0$

Figure 2. Two-dimensional computational results of the flow field about an NACA 0012 airfoil. $Re = 1400$.

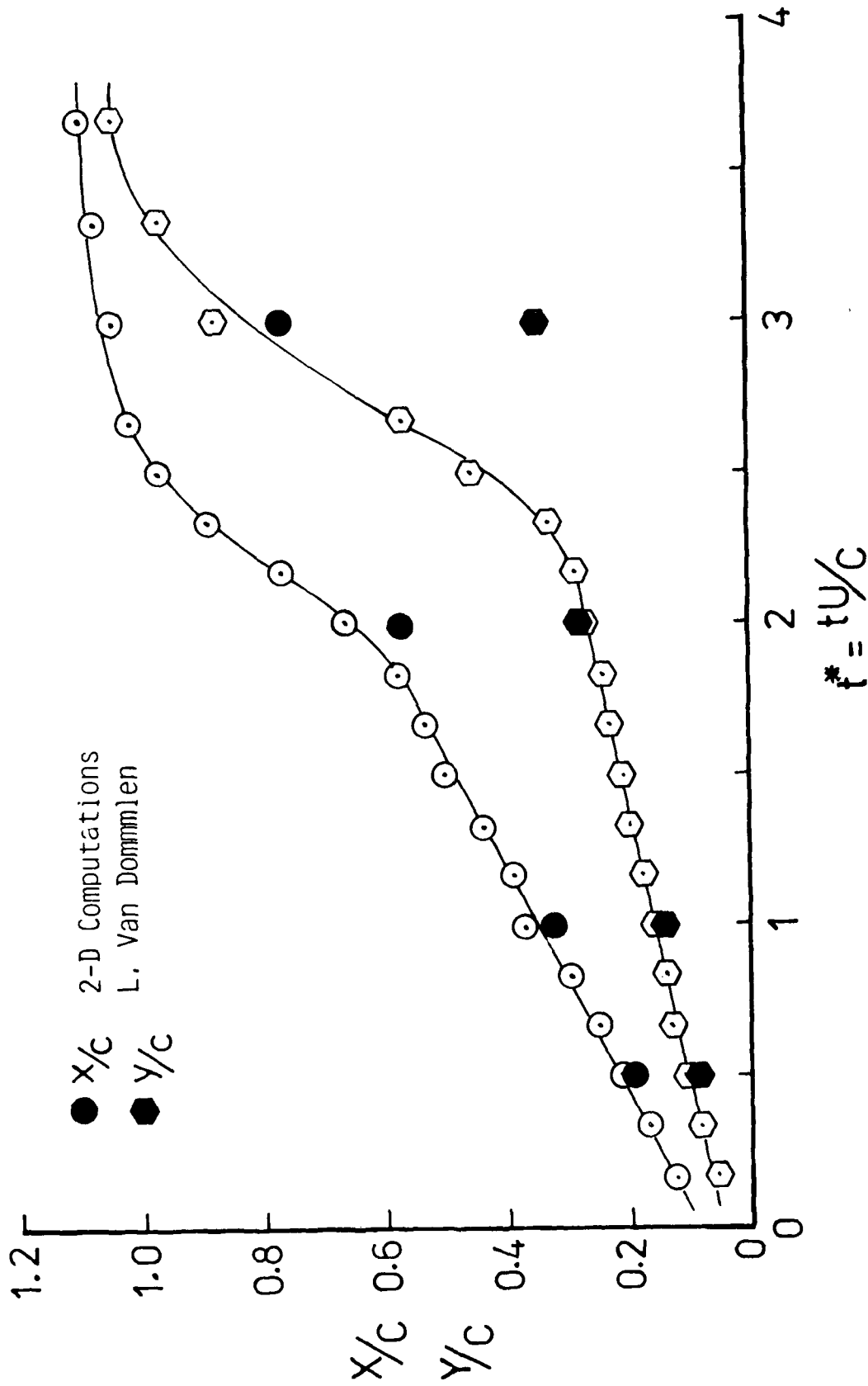

Figure 3. The variation of the primary vortex location with time. Angle of attack = 30 degrees, Re = 1400.

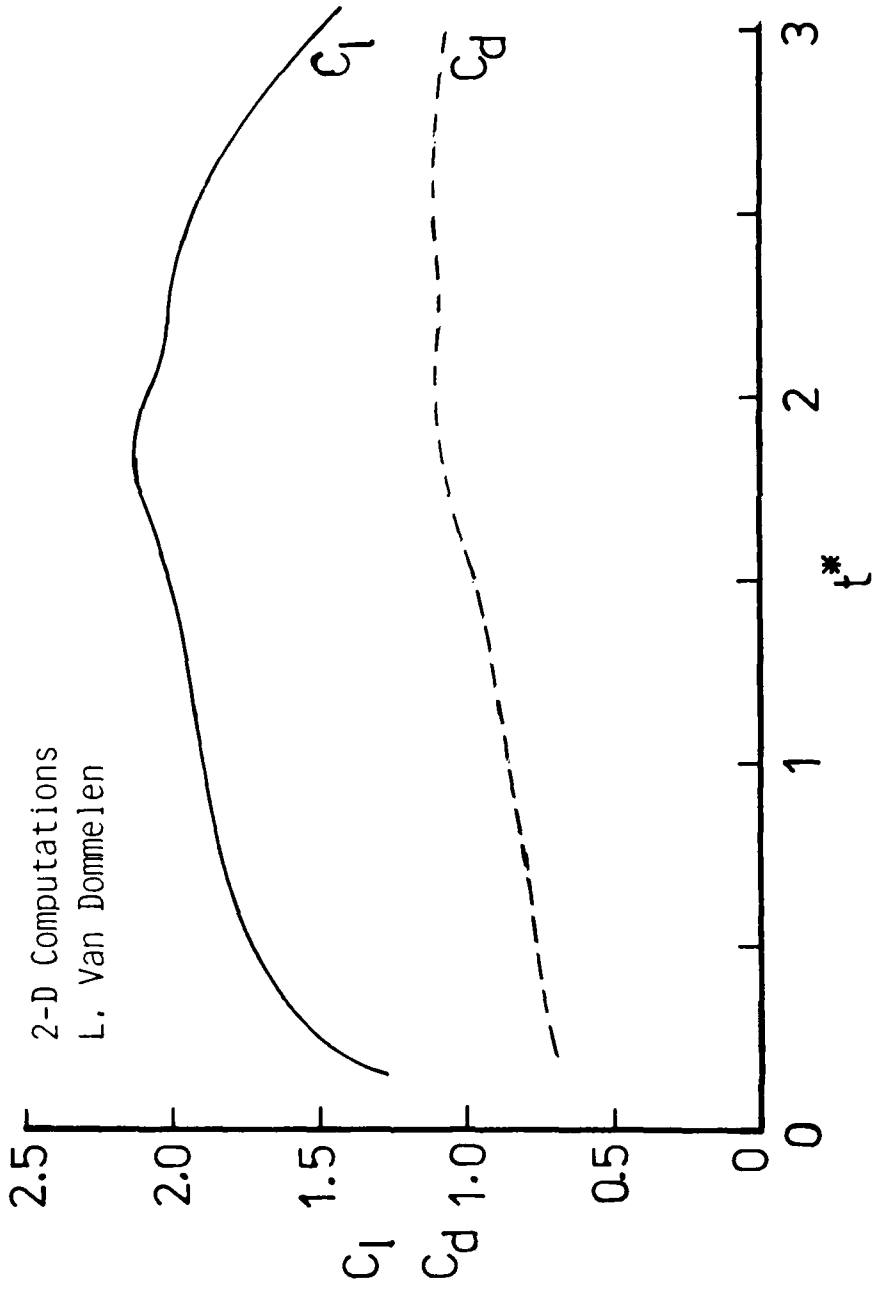

Figure 4. The variation of the computed lift and drag with time.
 C_l and C_d are nondimensional lift and drag coefficients.
 $Re = 1400$, angle of attack = 30 degrees.

Publications

1. A. Krothapalli, and L. Lourenco, "Unsteady Separated Flows: A Novel Experimental Approach", AIAA paper no. 87-0459, 25th Aerospace Sciences meeting, Reno, Nevada, January 1987.
2. L. Lourenco, M.S. Chandrasekara, and A. Krothapalli, "On the unsteady flow past an impulsively started airfoil at a high angle of attack", presented at the ASME Applied Mechanics, Bioengineering and Fluids Engineering Conference - Forum on Unsteady Flow Separation, Cincinnati, Ohio, June 1987, FED, vol. 52, p. 199.
3. L. Van Dommelen, "Unsteady Separation from a Lagrangian Point of View", presented at the ASME Applied Mechanics, Bioengineering and Fluids Engineering Conference - Forum on Unsteady Flow Separation, Cincinnati, Ohio, June 1987, FED, vol. 52, p. 81.
4. A. Krothapalli, L. Lourenco and L. van Dommelen, "PIDV Measurements of the Flow Field about a High Angle of Attack Wing", to be submitted to *AIAA Journal*.

Professional Personnel

Faculty:

1. Dr. Anjaneyulu Krothapalli, Professor and Chairman, Department of Mechanical Engineering, Principle Investigator.
2. Dr. Luiz Lourenco, Assistant Professor, Department of Mechanical Engineering, Co-Principle Investigator.
3. Dr. Leon van Dommelen, Assistant Professor, Department of Mechanical Engineering (Funded by the Department of Mechanical Engineering).

Visiting Faculty:

Dr. M.S. Chandrasekhara (7/86 - 6/87) Visiting Assistant Professor.

Graduate Students:

Mr. Ramesh Arjunji, M.S. Student, Department of Mechanical Engineering.

Presentations and Seminars

Dr. A. Krothapalli

1. Department of Aerospace Engineering Seminar Virginia Polytechnique Institute, July 1987.
2. Unsteady Aerodynamics Branch Seminar, NASA Langley Research Center, July 1987.
3. Poster Session, 26th Aerospace Sciences Meeting, Reno, Nevada, January 1988.

Dr. L. Lourenco

1. Department of Aerospace Engineering Seminar, University of Southern California, October 1987.
2. ASME Winter Annual Meeting (panel member), Boston, Massachusetts, December 1987.
3. Lecture Series, Von Karman Institute for Fluid Dynamics, Brussels, Belgium, March 1988.

APPENDIX I

AIAA'87

AIAA 87-0459

**Unsteady Separated Flows: A Novel
Experimental Approach**

A. Krothapalli and L. Lourenco

The Florida State University, Tallahassee, FL

AIAA 25th Aerospace Sciences Meeting

January 12-15, 1987/Reno, Nevada

For permission to copy or republish, contact the American Institute of Aeronautics and Astronautics
1633 Broadway, New York, NY 10019

UNSTEADY SEPARATED FLOWS: A NOVEL EXPERIMENTAL APPROACH

A. Krothapalli* and L. Lourenco**

Department of Mechanical Engineering
FAMU/FSU College of Engineering
The Florida State University, Tallahassee, FL 32306

Abstract

A novel experimental technique, commonly referred to as Laser Speckle Velocimetry (LSV) or Particle Image Displacement Velocimetry (PIDV), is developed for the measurement of instantaneous velocity fields in unsteady and steady flows. The main advantage of this technique is that the velocity field is measured with sufficient accuracy so that the distribution of vorticity can be calculated with accuracy.

The PIDV technique, which is ideally suited for the study of unsteady separated flows, has been utilized to measure the development of the separated flow field generated by an high angle of attack ($\alpha=30^\circ$) NACA 0012 airfoil started impulsively from rest.

1. Introduction

For the solution of many problems that occur in high angle of attack aerodynamics, it is a necessary to have a thorough understanding of the behavior of unsteady separated flows. Although much progress has been made in predicting the steady flow phenomenon with the use of numerical methods, it is still difficult to predict unsteady flows which contain flow separation. The difficulty mainly arises from the fact that these flows are extremely complex and are not amenable to standard experimental and numerical techniques. In view of this, a novel experimental technique is being developed for the measurement of instantaneous velocity fields in unsteady and steady fluid flows. This paper provides a description of this technique along with its successful application to the study of an unsteady separated flow generated by an high angle of attack airfoil.

In an unsteady flow, a single photograph of the flow pattern at a given instant does not generally provide any meaningful information. In order to understand the unsteady flow phenomena, it is necessary to obtain both spatial and temporal information of the entire flow field. With this in mind, optical techniques have been widely used to observe and measure properties of flow fields such as velocities and densities. Many of these techniques are qualitative in nature, but of great value in guiding intuition and in suggesting ways to investigate the problem by quantitative means. An admirable review of the modern optical techniques in fluid mechanics is

given by Lauterborn and Vogel¹, and the reader is referred to this article for details. A quantitative flow visualization technique would be very helpful in the study of these flow fields. Attempts to accomplish this task by tracing the streaklines of injected particles^{2,3} usually can not provide the spatial resolution that is required and a large amount of labor is necessary to reduce the data.

In unsteady separated flows, as will be shown later, it is often desirable to obtain the vorticity field, in addition to the velocity field. However, measurement of the vorticity exceed the present experimental capability. This difficulty arises from the fact that vorticity is a quantity defined in terms of local velocity gradients. In contrast, the currently available measurement techniques, such as hot-wire anemometry or laser velocimetry, are sensitive only to the local velocity. Hence, measurements must be made over several points and the resulting velocity components are then analyzed by finite difference schemes. However, the errors produced by the necessary differentiations limit the accuracy and spectral range. In addition, the spatial resolution of this method is often not sufficient to measure small-scale fluid motions or rapidly changing velocity gradients. As a consequence, the measured vorticity field is a type of spatially averaged estimate of the actual vorticity field. Finally, this method provides information at only a single point. If information on the entire flow field is required, measurements must be carried out sequentially one point at a time. This sequential method, although laborious, is straightforward in applications involving steady flows. However, the method becomes very difficult, if not impossible to implement, when studying unsteady flows. Direct measurement of vorticity has been tried, for instance, by injection of spherical particles which rotate in the flow with an angular velocity proportional to the local vorticity⁴. Such methods suffer the same drawback of insufficient spatial resolution just mentioned and also can be quite complex.

Recently, a novel velocity measurement technique, commonly referred to as Laser Speckle Velocimetry (LSV) or Particle Image Displacement Velocimetry (PIDV) has become available. This technique provides the simultaneous visualization of the two-dimensional streamline pattern in unsteady flows as well as the quantification of the velocity field over an entire plane. The advantage of this technique is that the velocity field can be measured over an

* Associate Professor and member of AIAA
** Assistant Professor and member of AIAA

entire plane of the flow field simultaneously, with accuracy and spatial resolution. From this the instantaneous vorticity field can be easily obtained. This constitutes a great asset for the study of a variety of flows that evolve stochastically in both space and time, such as the unsteady vortical flows that occur in rotorcraft and high-angle-of-attack aerodynamics. For the background of this present technique, the reader is referred to reference 5.

The principle of the technique is given in the next section followed by the description of the apparatus, instrumentation and procedures. Section 4 provides the results and their description for the flow over an high angle of attack NACA 0012 airfoil.

2. Principle of the Technique

The application of LSV or PIDV to fluid flow measurement involves several steps. First, it is necessary to "create" a selected plane or surface within the flow field. This is accomplished by seeding the flow with small tracer particles, similarly to LDV applications, and illuminating it with a sheet of coherent light, as shown in Figure 1. A pulsed laser such as a Ruby or a NdYag laser, or a CW laser with a shutter is normally used as the light source. The laser sheet is formed, for example, by focusing the laser beam first with a long focal length spherical lens, to obtain minimum thickness, and then diverging the beam in one dimension with a cylindrical lens. The light scattered by the seeding particles in the illuminated plane provides a moving pattern. When the seeding concentration is low, the pattern consists of resolved diffraction limited images of the particles. When their concentration increases, the images overlap and interfere to produce a random speckle pattern. A multiple exposure photograph records this moving pattern. The lower particle concentration originates a mode of operation of the technique referred to as Particle Image Displacement Velocimetry, reserving the term Laser Speckle Velocimetry for the high particle concentration levels where a random speckle pattern is actually formed (reference 6). In a second step the local fluid velocity is derived from the ratio of the measured spacing between the images of the same tracer, or speckle grain, and the time between exposures.

Several methods exist to convert the information contained in the multiple-exposed photograph, or specklegram, to flow field data such as velocity or vorticity. The recorded image, whether formed by isolated disks, in the case of low particle concentration, or speckle grains for high particle concentration is a complicated random pattern. It would be very difficult to measure the local displacements by visual or computer-aided inspection. However, it is important to realize that the multiple exposure photograph results in a periodic random image from which the periodicity information can

be retrieved using Fourier or Auto-correlation analysis. Basically, the multiple-exposed photographs or specklegrams can be analyzed either on a point-by-point basis, which yields measurements of the local displacements (velocity), (refs. 7-8) or with a whole field filtering technique, which yields isovelocity contours (ref. 9). The method, which has been selected and implemented by the Fluid Mechanics Research Laboratory at the Florida State University, is the Young's fringes method. The local displacement is determined using an focused laser beam to interrogate a small area of the multiple exposed photograph transparency. The diffraction produced by coherent illumination of the multiple images in the negative generates Young's fringes, in the Fourier plane of a lens, provided that the particle images correlate. This is shown schematically in Figure 2. These fringes have an orientation which is perpendicular to the direction of the local displacement and a spacing inversely proportional to the displacement. The use of Young's fringes eliminates the difficulties of finding the individual image pairs in the photograph. The basis of the Young's fringe method is described in reference 8.

The photographic recording method discussed above has the disadvantage that the photograph consists of particle pairs which have a 180 degree ambiguity in the direction of the velocity vector. In addition, it has been shown (reference 10) that the velocity dynamic range of the technique is limited to a maximum value of about 10. In most flows of interest (e.g. boundary layers and separated flows), this dynamic range is not sufficient to capture the flow field in its entirety. These limitations are critical when measuring complex flows having flow reversals and stagnation areas.

A method to resolve both the ambiguity of the velocity vector as well as to improve the technique's velocity range is incorporated in this experiment. This method, proposed by Lourenco¹ and Adrian², commonly known as "velocity bias technique", consists of recording the flow field in a moving reference frame, thus superposing a known velocity bias to the actual flow velocity. This effect may be accomplished in several ways, in particular, using a moving camera during the photographic recording or by optical means using scanning or rotating mirrors. For the data presented here, a rotating mirror was used to displace the image during the exposure with a pre-determined velocity. A schematic of the rotating mirror arrangement is shown in figure 3. Consider two particle pairs A_0B_0 and C_0D_0 having equal displacements in opposite directions in the object plane. By introducing a 45° mirror between the camera lens and the object plane, the corresponding displacements appear in the film plane as AB and CD with equal magnitudes. When the mirror is rotated by an angle of $\Delta\theta$ between exposures, the displacements corresponding to A_0B_0 and C_0D_0 appear in

the film plane as AB¹ and CD¹ with different magnitudes. The correct displacement or velocity with its direction can now be obtained upon removal of the velocity bias. An example of the flow field obtained with and without the velocity bias can be seen in figure 4. This flow represent a typical separated flow field containing flow reversal and stagnation areas (a discussion of this flow field is given later).

3. Apparatus, Instrumentation and Procedures

The time-space development of the unsteady separated flow generated by an high angle of attack ($\alpha=30^\circ$) NACA 0012 airfoil impulsively started from rest is examined using Particle Displacement Velocimetry. The flow is created by towing the airfoil in the reduced scale Fluid Mechanics Research Laboratory towing tank facility. The tank is 300 x 200 x 500 mm. A detailed examination showed that the motion of the towing carriage is smooth and vibration free. The towing carriage is driven by a variable D.C. motor, and the towing velocity can vary from 0 to 100 mm/sec. For the photography, a 35mm camera (Nikon F-3) is used. To photograph the flow at regular time intervals, the photographic camera has a electric winding device. The photographic time interval available with this camera can be continuously varied up to a maximum of 6 frames per second. Two options are available to fix the camera; one by attaching it to the towing carriage, which means an observation point fixed in relation to the model, and the other by attaching it to the frame of the water tank, which means an observation point fixed in relation to the fluid. The selection of these two depends upon the flow field being photographed.

In this experiment the airfoil chord is 60mm and is towed with a velocity of 22mm/sec. The corresponding Reynolds number was 1400. The fluid used in this experiment was water seeded with 4 μ m metallic coated particles (TSI model 10087). For the illumination, a laser beam from a 5 Watt Argon-Ion Laser (Spectra-Physics series 2000) is steered and focused to a diameter of .3mm using an inverse telescope lens arrangement. A cylindrical lens, with a focal length of -6.34mm, is used to diverge the focused beam in one dimension, creating a light sheet. The laser sheet is 70mm wide and illuminates the mid-span section of the airfoil. For the multiple exposure, the CW laser beam is modulated using a Bragg cell. In this experiment, the laser power density, I_0 , of the sheet was .27 W/mm². In order to record the time development of the flow field, the camera was attached to the towing carriage and the frequency of which the multiple exposures were taken was set at 2.0Hz. The aperture of the lens with a focal length of 50mm and a spacer of 12mm, was set at F#5.6 and the resulting magnification factor was 0.40. For the multiple exposure, the time between exposures, T, and the exposure

time, t, are chosen according to the criteria discussed in reference 6. The time between exposures was 10msec. For optimum exposure, the exposure time was 1msec, which corresponded roughly to (d_p/MV_{max}) , where D is the analyzing beam diameter, V is the maximum expected velocity plus the shift velocity in the field and d_p is the particle image diameter expressed in terms of

$$d_i = (d_p^2 + d_s^2)^{1/2}$$

with d_p the particle diameter and d_s the edge spread caused by the limited response of the recording optics (ref. 6).

Data Processing

The fringe images were acquired and analyzed using the digital image analysis system of the Florida State University FMRL (Fig. 5). This system consists of the following components: a DEC LSI-11/73 host computer, Gould IP-8500 Digital image processor which includes four memory tiles for storage of image data in a 512 x 512 format with a resolution of 8 bit per pixel, a frame digitizer, a pipeline processor and a video output controller to convert digital to analog information for display on a color monitor. The system also includes a two-dimensional Klinger traversing mechanism with a controller for the purpose of automatically scanning the film transparencies. Two methods are available and used for fringe analysis (ref. 10). The first one is an interactive method in the sense that it requires the assistance of an operator.

The inconvenience of the one-dimensional averaging method is the need for an external adjustment of the angle of the fringes by an operator. This problem can be by passed by computing the velocity components along independent directions. Because each line of the fringe frame can be considered as a noisy periodic signal with variable phase, the automatic determination of a velocity component can be performed only by averaging over a quantity independent of the phase. The autocorrelation for each line or its Fourier transform for the power spectrum satisfies this requirement. The m velocity component can be computed from:

$$g(u) = \frac{\sum_{n=0}^{511} \left[\frac{\sum_m \{ I(m,n) I(m+u,n) \}}{\sum_m \{ I(m,n) \}^2} \right]}{-511 < u < 511}$$

This algorithm has been implemented using the pipeline processor of the Gould IP-8500 image processor to perform simultaneously the autocorrelation for all the lines of a frame. For an accurate estimate of the velocity magnitude and directions, four of such full image operations, yielding four autocorrelation functions, are required. From these the velocity vector is determined by selecting the values of the components which have been computed from autocorrelations having the

highest SNR, and visibility. (The computation, which includes the determination of the fringe angle and position updating of the film transparency scanning mechanism, is completed in a few seconds, typically 4-5 sec, using the PDP 11-73 computer.)

The overall accuracy of the technique was evaluated using a method described in reference 10. A uniform flow field is created by producing a multiple exposure photograph of the still seeded water, in the water tank, with a camera moving at constant speed. For the multiple exposure photograph a number of time between exposures are used, thus resulting in photographs with particle pairs at different known distances.

In the absence of a systematic bias, the standard deviation of the obtained velocity distribution is an estimate of the mean measurement error. From the error analysis, it is believed that the velocity data is obtained with an accuracy of 2 percent or better.

4. Results and Discussion

Typical multiple exposure photographs of the flow generated by the impulsively started NACA 0012 from rest for different times are shown in figure 6. The photographic arrangement was purposely adjusted to enhance the view of the flow field on the upper surface of the airfoil rather than to show the entire flow around the airfoil. Consequently, the details of the flow under the airfoil can not be seen clearly in these photographs. The angle of attack of the airfoil is set at 30° . These pictures display the flow field from the leading edge to a downstream location of about 1.5 chords. Photographs were taken at a frequency of 2Hz. A total of 34 pictures were obtained covering the range of t^* from 0.1 to 5. The non-dimensional time, $t^* (= Ut/c)$, where U is the free stream velocity, t is the time between two successive pictures, and c is the chord of the airfoil) between successive pictures was 0.167. However, in figure 6, only a limited number of pictures are included. The quadruple exposed photographs shown here increase the SNR (signal to noise ratio), the fringe visibility, and provide an excellent flow visualization. The added advantage of providing a good flow visualization is an asset of the PIDV technique.

From the flow visualization pictures shown in figure 6, the following observations are made. At the start of the airfoil a vortex, at the trailing edge, commonly known as "starting vortex", is generated and is carried away from the body. concomitant with this is the generation of a separation bubble at the leading edge of the airfoil (figure 4a). At a later time, for example at $t^* = 1.2$ (figure 4b), the separation bubble grows into an isolated primary vortex with "secondary vortices" following behind it. Similar type of vortex structure was also observed¹⁰ in the flow behind a circular

cylinder. This multiple vortex structure continue to grow together until the t^* reaches a value of about 2.5 (figure 4c and 4d). At $t^* = 2.5$ (figure 4d), because of the close proximity of the primary vortex, a trailing edge vortex is generated. At $t^* = 2.75$ the primary vortex abruptly moves away from the surface of the airfoil leaving behind a "vortex sheet" like structure (figure 4e). For $t^* > 3.0$, this "vortex sheet" rolls up into distinct vortices and they grow in size with time as shown in figure 4f - 4g. During this process, the trailing edge vortex also grows and as a result the whole flow field becomes very complex. Close to the surface of the airfoil, a small vortex remain present for $t^* > 3.0$. This vortex has the same sign of rotation as the trailing edge vortex. A similar vortex structure was observed by Ho¹³, who calls it an "induced vortex" and associates it with unsteady separation phenomenon.

The velocity data is acquired in a Cartesian mesh by digital processing of the Young's fringes, produced by point-by-point scanning of the positive contact copy of the photograph. The scanning step size and the dimension of the analyzing beam are 0.5mm, which corresponds to a spatial resolution of about 1.25mm in the object plane or about 0.02c. The fringes were processed using the method described in the previous section. The resultant two-dimensional velocity fields, corresponding to figure 6a - 6h, are shown in figure 7. The length of each vector is proportional to the local velocity at that point. The color code superimposed on the velocity data represents the vorticity level, the magnitude of which is given by the color bar at the bottom of the picture. The red and green colors represent the peak positive and negative vorticity regions respectively. This type of display clearly depict the various regions of vorticity and its strength. As discussed above, the presence of primary vortex, secondary vortices, vortex sheet trailing edge vortex and the induced vortex on the surface of the airfoil are clearly depicted along with their time-space development. The detailed analysis of this data is being conducted at this time and will be reported later.

5. Conclusions

A recently developed velocity measurement technique, known as Particle Image Displacement Velocimetry (PIDV), has been briefly described. Using this technique, the time-space evolution of the flow generated by an impulsively started high angle of attack ($\alpha=30^\circ$) NACA 0012 airfoil is presented. This experiment illustrated the technique's capabilities to record with accuracy the complex unsteady separated flow.

The technique has been shown to provide both flow visualization and quantitative measurements, which include the velocity and vorticity fields.

The unsteady separated flow field generated by an high angle of attack airfoil contains many large scale vortical structures such as; primary vortex generated at the leading edge with secondary vortices upstream of it, trailing edge vortex, vortex sheet and an induced vortex in the upper surface of the airfoil. The origins and time development of these are clearly depicted by the instantaneous velocity and vorticity fields obtained using PIDV.

Acknowledgments

The development of the PIDV is generously supported by the Aeromechanics branch of NASA Ames Research Center under grant no. NAG 2-314. While the study of the unsteady flow past high angle of attack airfoils is supported by the Air Force Office of Scientific Research under grant no. AFOSR-86-0243.

References

1. Lauterborn, W., and Voget, A., "Modern Optical Technique in Fluid Mechanics", Annual Review of Fluid Mechanics, vol. 16, 1984, pp 223-244.
2. Gharib, M., Herman, M.A., Yavrouian, A.H., and Sarohia, V., "Flow Velocity Measurement by Image Processing of Optically Activated Traces", AIAA paper no. 85-0172, 1985.
3. Dimotakis, P.E., Debussy, F.D., and Koochesfahani, M.M., "Particle streak Velocity Field Measurements in a Two-dimensional Mixing Layer", Physics of Fluids, vol. 24, 1981, pp 995-999.
4. Frish, M.B., and Webb, W.W., "Direct Measurement of Vorticity by Optical Probe", Journal of Fluid Mechanics, vol. 107, 1981, pp 173-200.
5. Smith, C.A., Lourenco, L.M., and Krothapalli, A., "The development of laser speckle velocimetry for the measurement of vortical flow fields", AIAA paper no. 86-0768-CP, 1986.
6. Lourenco, L., and Krothapalli, K., "The role of photographic parameters in laser speckle or particle image displacement velocimetry", Experiments in Fluids, vol. 5, 1986, pp 29-32.
7. Yao, C.S., and Adrian, R.J., "Orthogonal Compression and 1-D Analysis Technique for Measurement of 2-D Particle Displacements in Pulsed Laser Velocimetry", Applied Optics, vol. 23, 1984, pp 1687-1689.
8. Lourenco, L., and Whiffen, M.C., "Laser Speckle Methods in Fluid Dynamic Applications", Laser Anemometry in Fluid Mechanics, Ladoan, Portugal, 1984, pp 51-68.
9. Collicott, S.H., and Hesselink, L., "Anamorphic Optical Processing of Laser Speckle Anemometry Data", Bull. Amer. Phys. Soc., 10, 1985, pp 1928.
10. Lourenco, L., and Krothapalli, A., "Application of PIDV to the Study of the Temporal Evolution of the Flow Past a Circular Cylinder", Proc. of Intn. Symp. on Laser Anemometry Application in Fluid Mechanics, Lisbon, Portugal, July 1986.
11. Lourenco, L., "Application of Laser Speckle and Particle Image Velocimetry in Flows with Velocity Reversal", Bull. Amer. Phys. Soc., vol. 31, no. 10, 1986, p. 1723.
12. Adrian, R.J., "Image Shifting to Determine the Polarity of Velocity Vectors Measured by Pulsed Laser Anemometry", Bull. Amer. Phys. Soc., vol. 31, no. 10, 1986, p. 1722.
13. Ho, C.M., "An Alternative Look at the Unsteady Separation Phenomenon", Recent Advances in Aerodynamics, Springer-Verlag, 1986, pp 165-178.

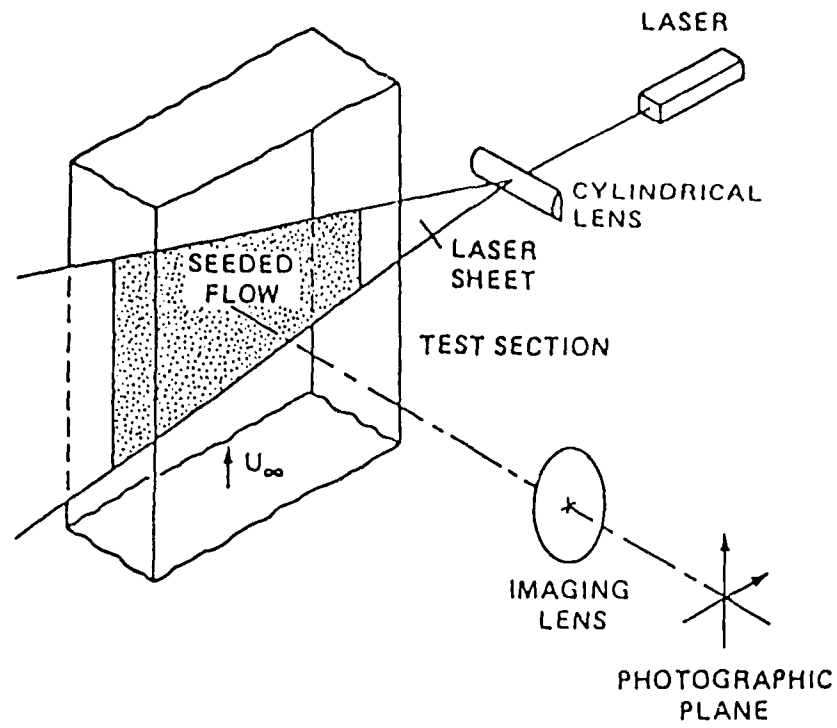

Figure 1. Schematic arrangement for the photographic recording.

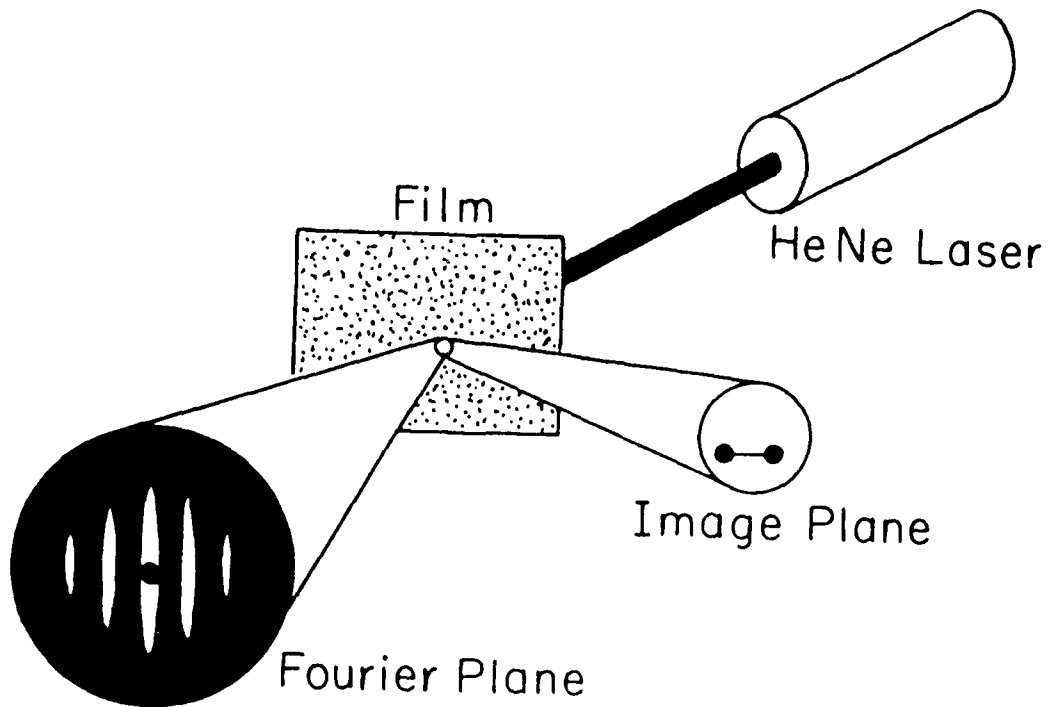

Figure 2. Schematic arrangement for obtaining Young's fringes.

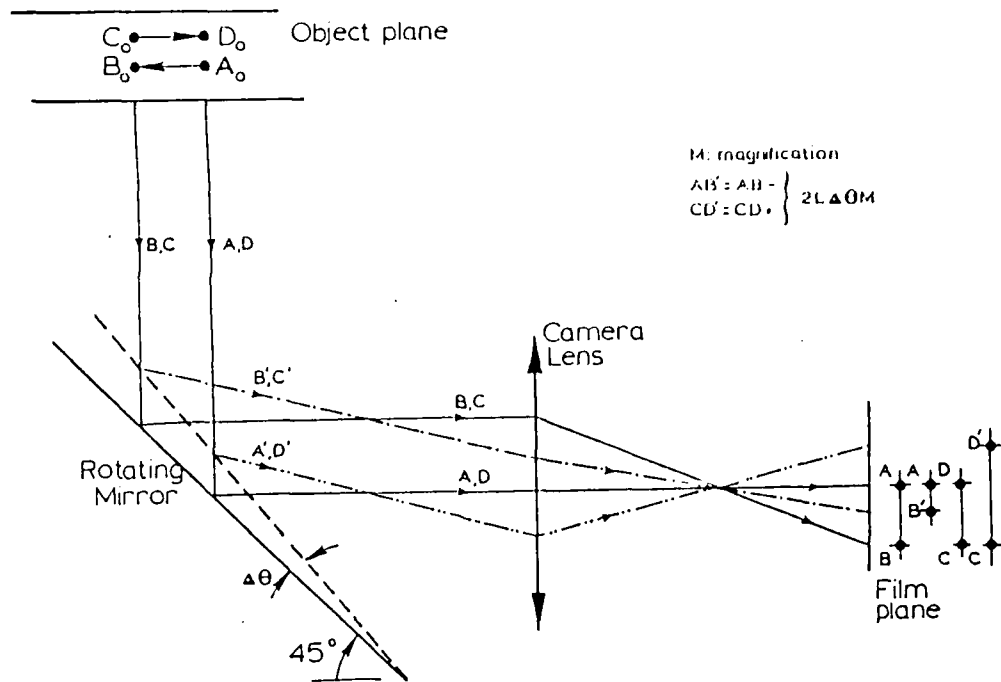

Figure 3. Rotating Mirror arrangement for the Velocity Bias Technique

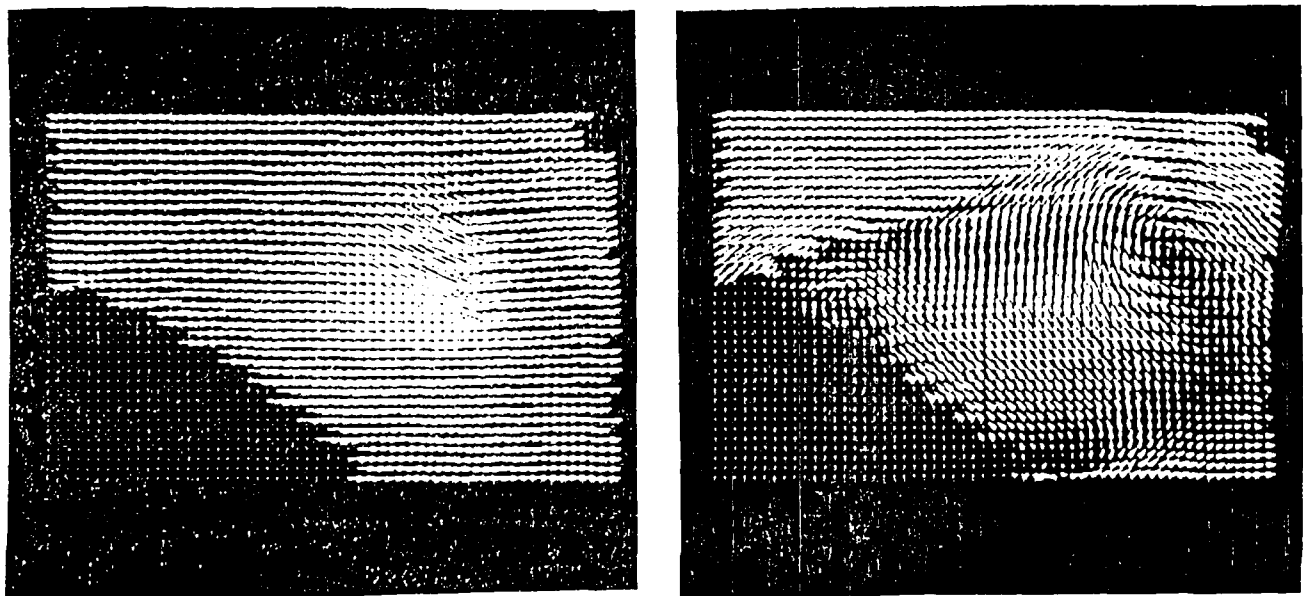

Figure 4. Instantaneous Velocity Field a) Before removal of velocity bias b) after removal of the velocity bias.

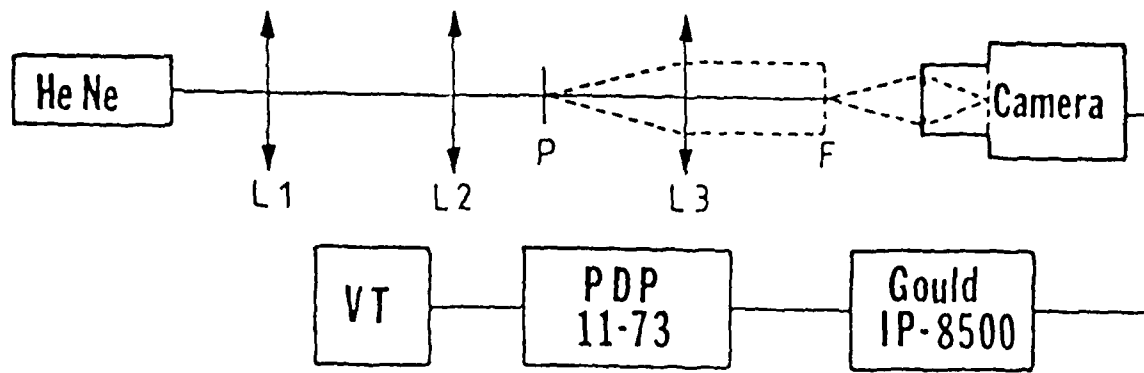

Figure 5. Schematic of the data analysis system

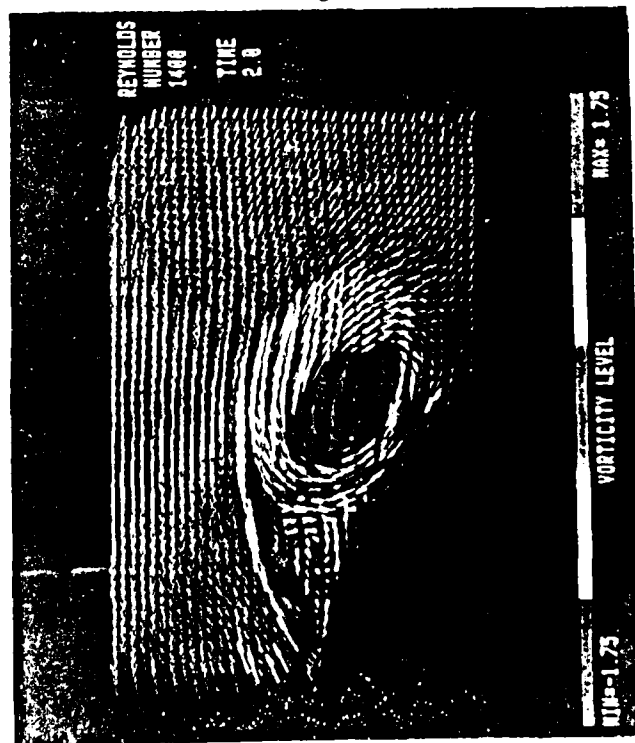
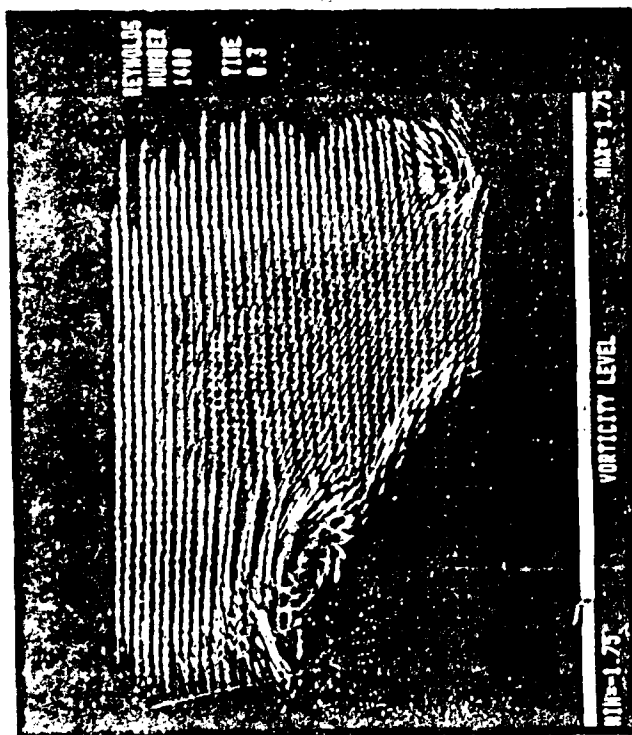
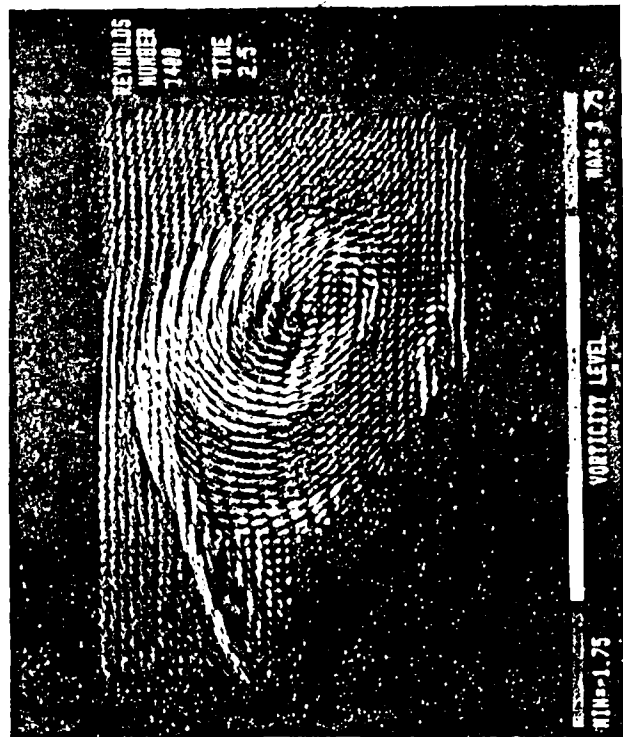
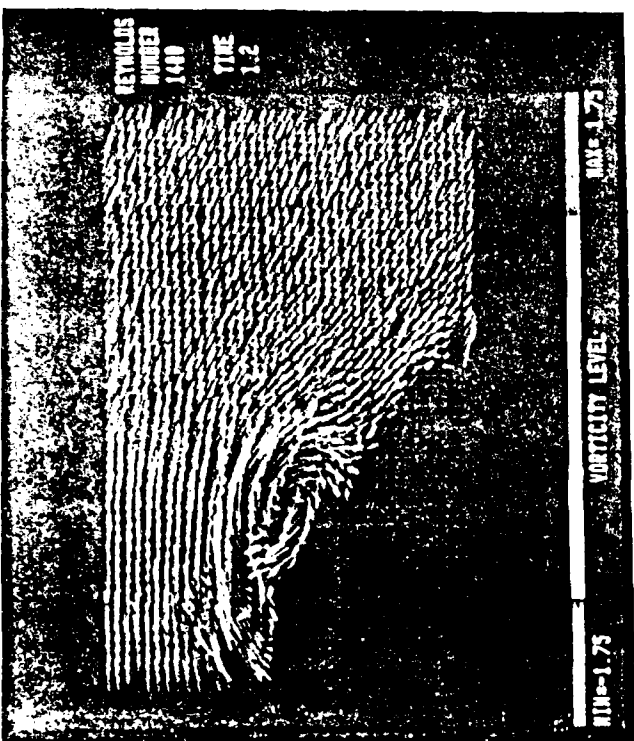

Figure 7. Continued

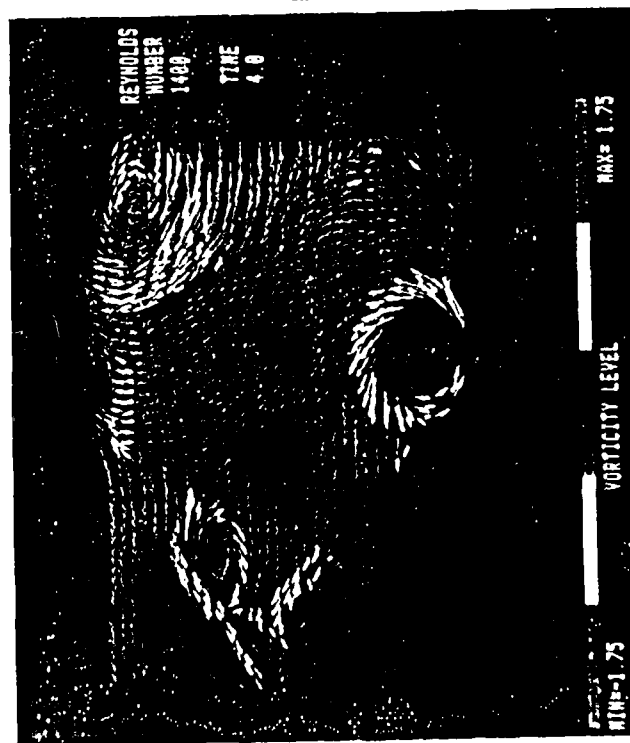
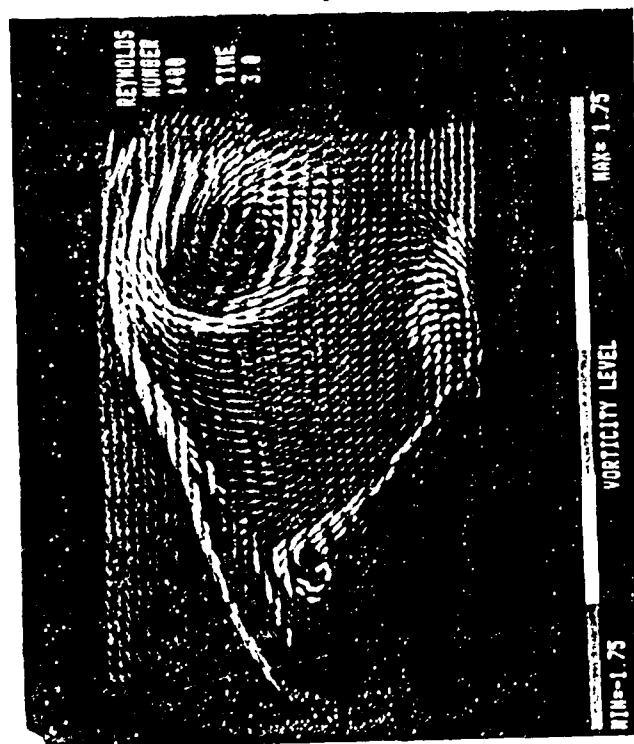
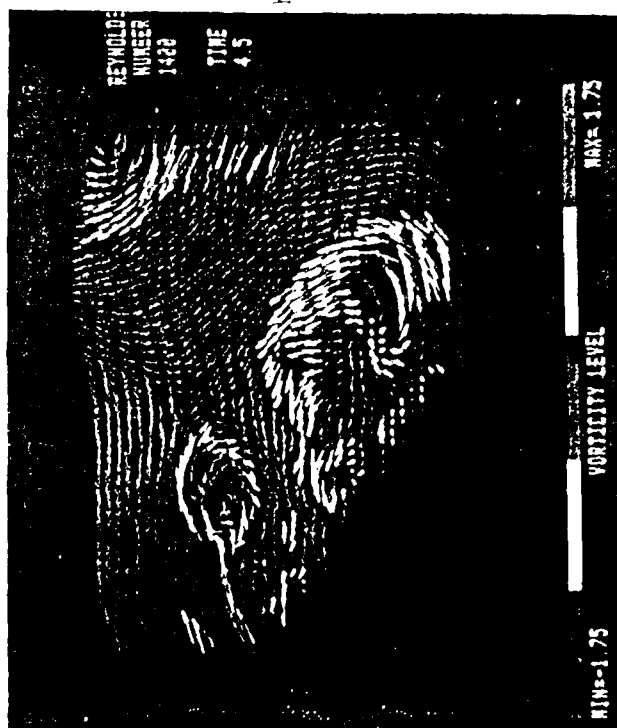
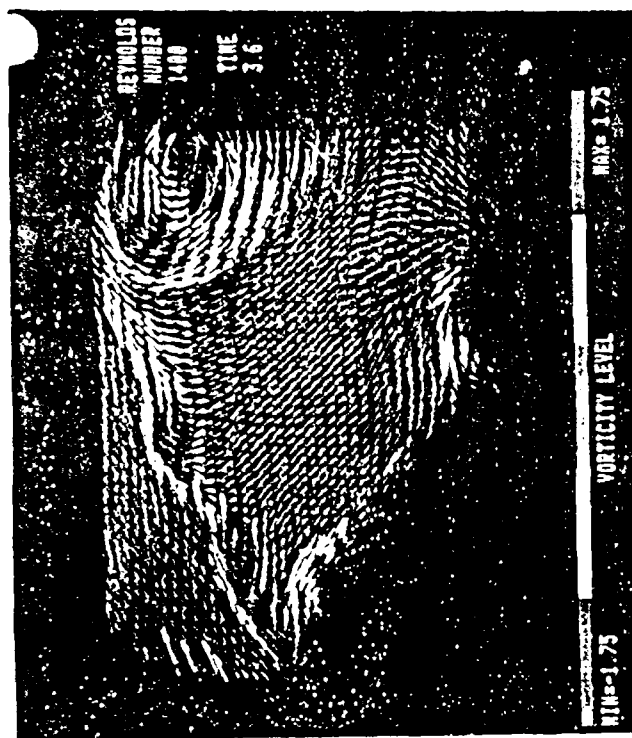

Figure 7. Instantaneous velocity and vorticity fields; a) $t^* = 0.3$; b) $t^* = 1.0$; c) $t^* = 2.0$

END

DATED

FILM

8-88

DTIC