

NO-A194 861

ULTRA-WIDEBAND DIRECTION FINDING USING A FIBER OPTIC
BEAMFORMING PROCESSOR(U) NAVAL OCEAN SYSTEMS CENTER SAN
DIEGO CA S A PAPPERT APR 88

1/1

UNCLASSIFIED

F/G 17/11

ML



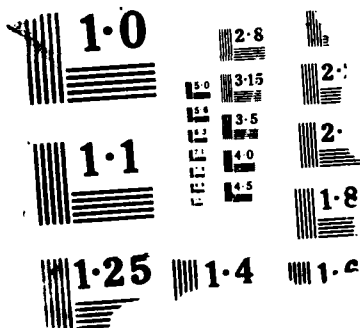



AD-A194 861

DOCUMENTATION PAGE

1a. REPORT UNCLASSIFIED		1b. RESTRICTIVE MARKINGS	
2a. SECURITY		3. DISTRIBUTION/AVAILABILITY OF REPORT	
2b. DECLASSIFICATION/DOWNGRADING SCHEDULE		Approved for public release; distribution is unlimited.	
4. PERFORMING ORGANIZATION REPORT NUMBER(S)		5. MONITORING ORGANIZATION REPORT NUMBER(S)	
6a. NAME OF PERFORMING ORGANIZATION Naval Ocean Systems Center	6b. OFFICE SYMBOL (if applicable) NOSC	7a. NAME OF MONITORING ORGANIZATION Naval Ocean Systems Center	
6c. ADDRESS (City, State and ZIP Code) San Diego, California 92152-5000		7b. ADDRESS (City, State and ZIP Code) San Diego, California 92152-5000	
8a. NAME OF FUNDING/SPONSORING ORGANIZATION Director of Naval Laboratories	8b. OFFICE SYMBOL (if applicable) DNL	9. PROCUREMENT INSTRUMENT IDENTIFICATION NUMBER	
8c. ADDRESS (City, State and ZIP Code) Space and Naval Warfare Systems Command Washington, DC 20360		10. SOURCE OF FUNDING NUMBERS	
		PROGRAM ELEMENT NO. 62766N	PROJECT NO. ZE32
		TASK NO. RZ66300	AGENCY ACCESSION NO. DN305 044
11. TITLE (include Security Classification) ULTRA-WIDEBAND DIRECTION FINDING USING A FIBER OPTIC BEAMFORMING PROCESSOR			
12. PERSONAL AUTHOR(S) S.A. Pappert			
13a. TYPE OF REPORT Presentation/speech	13b. TIME COVERED FROM Jan 1988 TO Jan 1988	14. DATE OF REPORT (Year, Month, Day) April 1988	15. PAGE COUNT
16. SUPPLEMENTARY NOTATION			
17. COSATI CODES		18. SUBJECT TERMS (Continue on reverse if necessary and identify by block number)	
FIELD	GROUP	SUB-GROUP	fiber optics delay lines signal processing devices direction funding optics
19. ABSTRACT (Continue on reverse if necessary and identify by block number) This paper describes a wideband electro-optic direction finding (DF) processor employing an array of laser diodes, an array of photo-detectors, and a network of fiber optic delay lines. This DF filter offers a potential operational bandwidth in excess of 10 GHz and allows for multiple, simultaneous beam angular responses with peaks which are independent of frequency. Two eight-laser, two-beam laboratory test model DF devices, one utilizing multimode optical fiber and the other single-mode fiber, were constructed. These experimental optical beamforming filters are operable in the 100-2000 MHz frequency range and can simultaneously monitor two angles of arrival. Experiments were performed to determine the two system's sensitivity, dynamic range, angular resolution, and frequency response. It is concluded from theoretical and experimental results obtained that the multimode DF device is slightly superior in performance to the single-mode system due to the higher throughput optical power levels possible with multimode systems. Further, it is concluded that this fiber optic beamforming processor can be a useful device for ultra-wideband DF. Presented at SPIE's O-E Lase '88, 13 January 1988, Los Angeles, California.			
20. DISTRIBUTION/AVAILABILITY OF ABSTRACT <input type="checkbox"/> UNCLASSIFIED/UNLIMITED <input checked="" type="checkbox"/> SAME AS RPT <input type="checkbox"/> DTIC USERS		21. ABSTRACT SECURITY CLASSIFICATION UNCLASSIFIED	
22a. NAME OF RESPONSIBLE PERSON S.A. Pappert	22b. TELEPHONE (include Area Code) 619-553-1066	22c. OFFICE SYMBOL Code 562	

DTIC
ELECTE
MAY 24 1988
S or H D

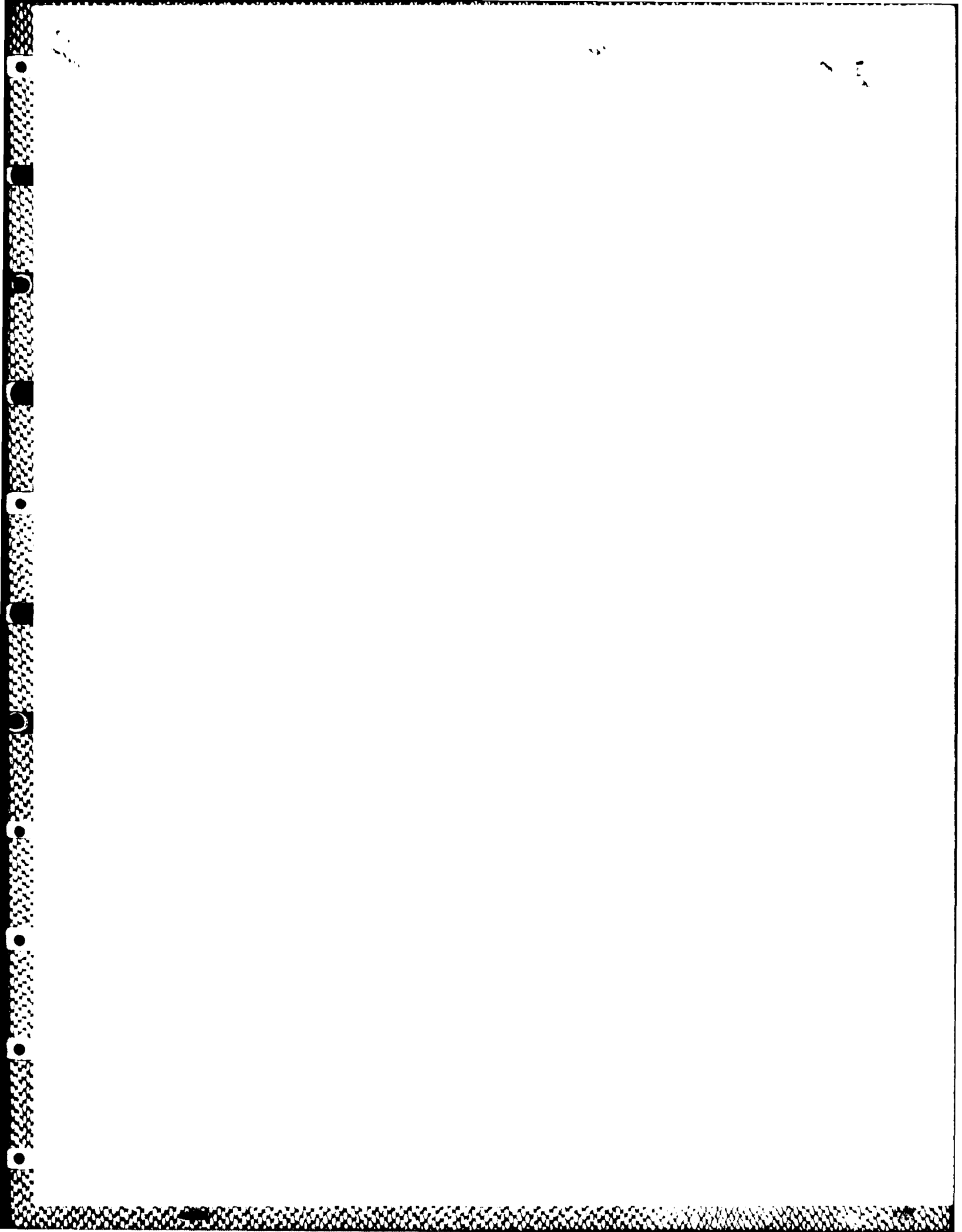

Ultra-wideband direction finding using a fiber optic beamforming processor

Stephen A. Pappert

Electronic Material Sciences Division, Naval Ocean Systems Center
San Diego, California 92152-5000ABSTRACT

This paper describes a wideband electro-optic direction finding (DF) processor employing an array of laser diodes, an array of photodetectors, and a network of fiber optic delay lines. This DF filter offers a potential operational bandwidth in excess of 10 GHz and allows for multiple, simultaneous beam angular responses with peaks which are independent of frequency. Two eight-laser, two-beam laboratory test model DF devices, one utilizing multimode optical fiber and the other single-mode fiber, were constructed. These experimental optical beamforming filters are operable in the 100-2000 MHz frequency range and can simultaneously monitor two angles of arrival. Experiments were performed to determine the two systems sensitivity, dynamic range, angular resolution, and frequency response. It is concluded from theoretical and experimental results obtained that the multimode DF device is slightly superior in performance to the single-mode system due to the higher throughput optical power levels possible with multimode systems. Further, it is concluded that this fiber optic beamforming processor can be a useful device for ultra-wideband DF.

1. INTRODUCTION

The fiber optic beamforming processor for angle of arrival (AOA) determination or matched-delay filter as it is sometimes referred to was first proposed at the Naval Ocean Systems Center (NOSC) in 1977¹. Actual research and development work was initiated on this optical processor at NOSC in 1984 and has steadily progressed to the present^{2,3,4}. This AOA device is essentially composed of many fiber optic transversal filters with each transversal filter matched to a single radio frequency (RF) angle of arrival. Operating in the time-delay mode rather than the phase-delay mode, this DF technique yields frequency independent RF arrival directions. This is an important feature of this processor. Other attractive features of the fiber optics matched-delay filter for use in wideband DF include the following:

- 1) it allows stationary DF platforms to be assembled that can simultaneously monitor different RF arrival angles.
- 2) it has a large instantaneous bandwidth (> 1 GHz).
- 3) it permits remote processing of the received RF signals yielding maximum electromagnetic interference/electromagnetic pulse (EMI/EMP) isolation.
- 4) the fiber optic components offer low cost, small size, and light weight.

This paper briefly reviews the operation of the fiber optics matched-delay filter and presents theoretical expressions for system sensitivity, dynamic range, and angular response. A description and experimental results of two eight-laser, two-beam laboratory DF systems operable in the 100-2000 MHz frequency range, one constructed with multimode optical fiber and the other with single-mode fiber, are presented and compared both with theoretical predictions and with each other. Areas of future research and development on this electro-optic beamforming processor are also given.

2. SYSTEM ANALYSIS

A schematic diagram of a single-beam fiber optics matched-delay filter for determining the AOA of an incoming RF signal is shown in Figure 1. In its simplest form it consists of an equally spaced linear antenna array, an array of laser diodes, a network of fiber optic delay lines, and a photodetector. The electrical current from each omnidirectional antenna due to an incoming RF signal modulates the optical power of individual laser diodes which are coupled to fiber optic delay lines. The delay lines are cut to specific lengths to produce the required delays to compensate for the time of arrival differences of the incoming RF signal at the various antennas (for a selected AOA) and produce equally time-delayed signals at the photodetector. The optical power from the fiber optic delay lines is incoherently summed on a high-speed photodiode. By analyzing the angular dependence of the detected optical signal, the AOA of the incident RF signal can be deduced.

The electrical power from the photodiode is proportional to²

$$g(f, \tau) = \frac{\sin^2(N\pi f\tau)}{\sin^2(\pi f\tau)}$$

(1)

REPRODUCED AT GOVERNMENT EXPENSE

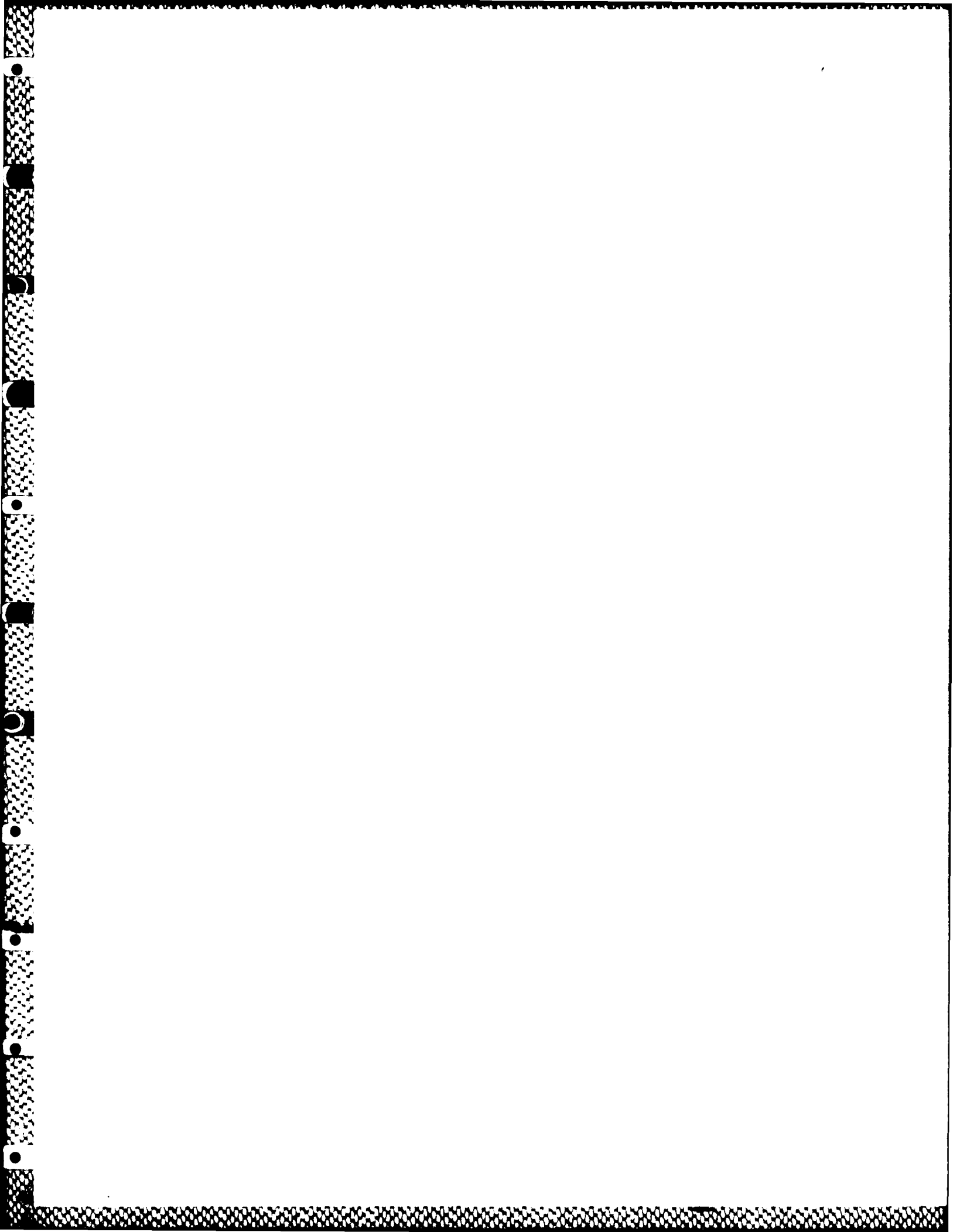

where N is the number of antennas in the array, f is the incoming signal frequency, and τ is the difference between RF arrival time and fiber time delay for any two adjacent antennas and is given by

$$\tau = \frac{n_g L - d \sin \theta}{c} \quad (2)$$

where c is the speed of light, d is the antenna spacing, n_g is the fiber group index of refraction, θ is the azimuthal RF angle of incidence measured from the normal to the array, and L is the adjacent fiber length difference which is a constant. The periodic function $g(f, \tau)$ is at a maximum for $\tau = 0$ independent of the frequency f which implies that the optical detector output will be at a maximum for only one angle of incidence θ_0 satisfying

$$\sin \theta_0 = \frac{n_g L}{d} \quad (3)$$

By employing a number of fiber delay lines for each laser diode, many transversal filters with different L can be constructed. Each filter will have a peak response at different θ_0 . This multibeam DF processor is schematically shown in Figure 2. Each photodetector has a unique "look" direction which is independent of frequency to give simultaneous azimuthal angular coverage.

To obtain expressions for the system sensitivity, dynamic range, and angular response, one must trace more carefully the RF signal path through the AOA processor. A single RF signal path from antenna through optical detector for a realistic matched-delay filter is depicted in Figure 3. The low-noise electrical preamplifier is included in this diagram for completeness although for this analysis, $P_{in} = P_s$, which implies an amplifier power gain of unity. The variable optical attenuator is required to allow equalization of the RF optical modulating powers transmitted by each fiber. After some analysis, the time-averaged RF electrical power from the k^{th} detector into an output resistor R_o can be shown to be⁴

$$P_o^k = P_s (R_o/R_L) (N L F r_D F_L M_D)^2 \left\{ \frac{\sin^2(N \pi f \tau_k)}{N^2 \sin^2(\pi f \tau_k)} \right\} \quad (4)$$

where

- N = number of lasers and antennas
- R_L = laser drive circuitry dynamic input resistance (ohms)
- r_D = detector responsivity (amps/watt)
- M_D = detector avalanche gain ($M_D = 1$ for a p-i-n photodiode)
- L_F = laser to detector optical throughput loss,

and where again

$$\tau_k = \frac{n_g L_k - d \sin \theta}{c}$$

as given before in Eq. (2). The optical throughput loss L_F can be expressed as⁴

$$L_F = \{ Y_{LF} Y_{FD} 10^{-(\alpha_F l_0/10)} 10^{-(\alpha_{1M}/10)} 10^{-(\alpha_{N1}/10)} 10^{-(\alpha_{FF}/10)} \} / M \quad (5)$$

where

- Y_{LF} = average laser to fiber coupling efficiency (%)
- Y_{FD} = average fiber to detector power coupling efficiency (%)
- α_F = transmission loss coefficient of optical fiber (dB/km)
- α_{1M} = excess loss of 1 to M fiber optic power dividers (dB)
- α_{N1} = excess loss of N to 1 fiber optic power combiners (dB)
- α_{FF} = average variable optical attenuator loss (dB)
- M = number of detectors and transversal filters
- l_0 = length of shortest optical fiber delay line.

In obtaining Eq. (4) it has been assumed that all the lasers and detectors have identical characteristics. The signal-to-noise ratio of the k^{th} detector $(S/N)_k$, defined in terms of the ratio of the mean square noise current, is given by⁴

$$(S/N)_k = \frac{(N L F M_D r_D F_L F_L)^2 \left\{ \frac{\sin^2(N \pi f \tau_k)}{N^2 \sin^2(\pi f \tau_k)} \right\}}{[2 e r_D M_D^2 F(M_D) L_F N O_o R_L + (4 k T R_L) / R_o] B_{eff}} \quad (6)$$

where

- O_o = average laser diode DC-biasing optical power (watts)
- B_{eff} = effective noise bandwidth of system (Hz)
- $F(M_D)$ = detector excess noise factor
- e = electronic charge.



Distribution/Availability Codes	
Dist	Avail and/or Special
A-1	

REPRODUCED AT GOVERNMENT EXPENSE

The minimum detectable input signal, or system sensitivity, under matched-delay conditions ($\tau = 0$) is given by

$$P_s^{\min} = \frac{\{2\epsilon_{rD} M_D^2 F(M_D) L_F N O_{rL} + (4KTR_L)/R_O\} B_{\text{eff}}}{(L_F N M_D r_L r_D)^2} \quad (7)$$

Limiting the laser intensity modulation to 80 % yields an electrical dynamic range given by⁴

$$(DR)_{\text{dB}} = 10 \log_{10} \left\{ \frac{(L_F N M_D r_D O_{rO})^2}{9(\epsilon_{rD} M_D^2 F(M_D) L_F N O_{rO} + 2KT/R_O) B_{\text{eff}}} \right\} \quad (8)$$

These expressions will be used to theoretically analyze and compare with experiment both multimode and single-mode DF processors.

3. EXPERIMENTAL CONFIGURATION

To experimentally investigate the direction finding capabilities of the fiber optics matched-delay filter in the 100-2000 MHz frequency band, two laboratory systems were assembled. The experimental setup for both systems is shown in Figure 4. One system employs multimode optical fiber delay lines and the other single-mode delay lines. These laboratory DF processors consist of 8 laser diodes, 2 high-speed optical detectors, and 16 fiber optic delay lines that are configured to simultaneously monitor 2 angles of arrival. The fiber delay lines are cut to produce adjacent fiber length differences of $L = 0$ and $L = 0.05$ m for the two transversal filters of both DF processors. A brief description of these two experimental DF systems is given below. For more details, the reader is referred elsewhere⁴.

Both laboratory DF systems use GaAlAs laser diodes operating at a wavelength of $\lambda = 0.83$ microns and which can be modulated to 2 GHz. Both systems employ silicon avalanche photodiodes (APDs) with 3 GHz modulation bandwidths for optical detection. Standard 6 micron step-index single-mode and 47 micron graded-index multimode optical fiber are used as the fiber optic delay lines. Four-port 3 dB fiber optic couplers fabricated in-house are used to produce the two output taps. The coupling efficiencies of the butt joined fiber coupler outputs and delay line inputs are adjusted to produce equal modulated powers transmitted by each delay line. This serves the function of the optical attenuators shown in Figure 4. An 8 to 1 multimode fiber optic power combiner is fabricated by cleaving an 8 X 8 port fused and tapered coupler in the fused and tapered region. The assembly is then packaged to form an efficient and uniform 8 to 1 optical power combiner. For the single-mode case, an 8 to 1 power combiner was fabricated by etching the fibers down to a 40 micron diameter and closely packaging the etched fibers inside a drawn down capillary tube.

A sweep oscillator is used to simulate the incoming RF signal. The oscillator is eight-way power divided to modulate the laser diodes. Different RF arrival angles are simulated by controllably varying the electrical lengths from the power divider to the individual lasers. For example, a simulated RF angle of arrival of $\theta = 0$ degrees is obtained if the electrical time delays from the power divider to the lasers are equal.

4. DF SIMULATION AND PERFORMANCE EXPERIMENTS

The two experimental fiber optics matched-delay filter systems were tested and evaluated in the 100-2000 MHz frequency range. The angular response of the two transversal filters of both the multimode and single-mode systems were measured for simulated RF arrival angles in the $-\pi/2$ to $\pi/2$ radians range for various frequencies within the band of interest. System sensitivity, dynamic range, angular resolution, and frequency response for each laboratory model were also evaluated. The multimode system experiments will be discussed first.

4.1 Multimode DF processor performance

The frequency response was determined by measuring the combined individual laser and detector frequency response and then investigating the response of each transversal filter. It was determined⁴ that the optical detectors used in the multimode system limited the frequency response to 1 GHz (3 dB rolloff frequency of detectors). The two transversal filters were designed to have peak detector responses at different incident angles. The filter with an adjacent fiber length difference $L = 0$ has a maximum detector output for a simulated RF arrival angle of $\theta_0 = 0$, which is independent of frequency as is evident from Eq. (3). The filter with an adjacent fiber length difference $L = 0.05$ m has a peak detector response for an arrival angle of $\theta_0 = 12$ degrees if an antenna spacing of $d = 0.35$ m in Eq. (3) is assumed. As a sample of the experimental data obtained, the theoretical and experimental angular responses of both transversal filters for $d = 0.35$ m and an incoming RF signal frequency of 500 MHz are shown in Figures 5(a) and 5(b). In obtaining these experimental angular response curves, the RF modulated optical power transmitted by each fiber delay line were made equal for each angle of incidence investigated. Experimental angular response curves with similar results were also obtained at frequencies of 250 and 1000 MHz.

The experimental sensitivity was found to be $P_{\text{S}}^{\text{EXP}} = -57$ dBm while the experimental dynamic range was found to be $(\text{DR})^{\text{EXP}} = 51$ dB. These values were obtained directly off the wideband spectrum analyzer (with a 1 MHz instantaneous bandwidth) by varying the input electrical power from a maximum level to the minimum detectable level.

The angular response curves displayed in Figure 5 show good agreement between theory and experiment, especially with respect to the position and angular width of the mainlobes. A FWHM beam width of approximately 11 degrees is shown in Figure 5(a). The sidelobe maxima of the experimental response curves of Figure 5 are within ± 2 dB of their expected values and at least 12 dB down from the mainlobe response. The small deviation from theory is attributed to a combination of unequal modulated optical powers transmitted by each fiber and to imprecise fiber optic delay times. The modulated optical powers in each fiber are measured equal to within ± 1 dB and the delay time measurement from the eight-way electrical power divider to the optical detector for each signal path is accurate to ± 40 ps. The system sensitivity and dynamic range are closely related to the largest achievable notch depth or sidelobe minimum relative the mainlobe peak. Using experimentally determined values of the terms given in Eqs. (7) and (8), theoretical predictions for sensitivity and dynamic range of $P_{\text{S}}^{\text{th}} = -75$ dBm and $(\text{DR})^{\text{th}} = 69$ dB are obtained. The 18 dB discrepancies between theory and experiment for sensitivity and dynamic range can be caused by a number of factors including fiber delay time inaccuracies and unequal modulated optical powers. Another possible factor contributing to the significant difference is modal noise associated with the various coupling components of this multimode system². These points will be discussed further in section 5 of this paper.

4.2 Single-mode DF processor performance

The frequency response of the single-mode eight-laser, two-transversal filter DF device was determined the same way as with the multimode system. The frequency response of this system was limited to 2 GHz by a combination of the electronic support equipment (i.e. electrical power dividers, connectors, and cables), laser diodes, and optical detectors. Angular response curves for the two transversal filters were obtained at various frequencies within the band of interest with similar results. As a representative sample of the obtained data, the theoretical and experimental angular responses for the $L = 0.05$ m filter for $d = 0.175$ m ($\theta_0 \approx 25$ degrees) and an incoming RF frequency of 1000 MHz is shown in Figure 6. The angular response of the $L = 0$ m filter for $f = 1500$ MHz and $d = 0.175$ m is plotted in Figure 7. The experimentally obtained sensitivity was found to be $P_{\text{S}}^{\text{EXP}} = -42$ dBm while the experimental dynamic range was found to be $(\text{DR})^{\text{EXP}} = 44$ dB. These values were again obtained with an effective noise bandwidth of 1 MHz due to the instantaneous spectrum analyzer bandwidth.

The angular response curves shown in Figures 6 and 7 show fair agreement between theory and experiment. Few data points could be obtained for the angular response at high frequencies due to the fact that the minimum experimentally achievable time-delay increment of 120 ps corresponds to large angular changes. In any event, the data points do suggest that our theoretical model is valid. The sidelobe maxima of the experimental response curves in Figures 6 and 7 are within ± 4 dB of their expected values and at least 11 dB down from the mainlobe response. Imprecise delay times and unequal optical modulating amplitudes are again believed to be the cause of error. The experimental measurement precision for the modulating optical powers and the fiber delay times were the same as that in the multimode system ($\Delta\tau \leq 40$ ps and $\Delta\alpha_{\text{mo}} \leq 1$ dB). Using experimentally measured values of the terms expressed in Eqs. (7) and (8) for sensitivity and dynamic range, theoretical values of $P_{\text{S}}^{\text{th}} = -58$ dBm and $(\text{DR})^{\text{th}} = 60$ dB are calculated. Fiber delay time inaccuracies and unequal modulated optical powers are theorized to be the cause of the large variance between theory and experiment for these two system parameters. Modal noise is nonexistent in this single-mode system which rules out its possibility. These points will now be further discussed.

5. DISCUSSION

Both of the DF filters that were tested in this research effort performed exceptionally well compared with theoretical predictions for frequency response and angular resolution. The DF filters did not perform so well with respect to sensitivity and dynamic range. Because different optical and electronic components were used for the laboratory single-mode and multimode DF systems, a direct comparison on the basis of these four important system parameters is not possible. Nevertheless, some useful information can be deduced from the experimental and theoretical results obtained.

The operational bandwidth of the single-mode DF system was approximately 2 GHz while the bandwidth of the multimode system was limited to 1 GHz. This variation in the frequency response of the two systems is not indicative of the difference in optical fiber employed, but rather a result of the particular choice of optical source and detector. It is the frequency response of the optical source and detector combination that ultimately limits the bandwidth of this DF device. The above results indicate that the laser diode and optical

detector combination used by the single-mode system was superior to that of the multimode case. Laser diodes with 12.5 GHz bandwidths have been reported⁶ and bandwidths to 20 GHz should be achievable in the very near future. Detectors with 20 GHz bandwidths have already been demonstrated⁷. The angular resolution of both systems agreed very well with theory at all frequencies investigated. There is no expected difference in the angular resolution performance of the single-mode and multimode systems due to optical fiber which was verified experimentally. Hence, an optical fiber choice cannot be made on the basis of frequency response and angular resolution alone. The optical fiber plays an important role in determining the system sensitivity and dynamic range and it is on these parameters that a fiber choice can be made.

The experimentally observed values for sensitivity and dynamic range for the multimode DF system were 18 dB smaller than theoretically predicted. The experimental and theoretical values for these two parameters differed by 16 dB for the single-mode device. These differences are substantial and imply detector-limited operation was not achieved with either system. In obtaining the theoretical expressions for sensitivity and dynamic range given respectively by Eqs. (7) and (8), ideal operating conditions were assumed. In an effort to explain the large discrepancies, the effect of introducing three important and independent sources of error or noise were considered. First, the possibility of unequal interfering amplitudes at the optical detector (a contrast error) was considered. Second, the effect of imprecise fiber delay times (a phase error) was considered. And third, the effect of modal noise on the two DF systems was considered. A summary of the findings will now be given. The interested reader is referred elsewhere for more details⁴.

To achieve detector-limited operation, much tighter error bounds on fiber delay times and optical modulation amplitudes are required. Delay times measured to within ± 1 ps and equal modulating optical powers to within ± 0.1 dB are needed to obtain detector-limited operation. Recall in our experiment, $\Delta\tau \approx 40$ ps and $\Delta O_{MO} \approx 1$ dB, which yields expected sensitivities and dynamic ranges slightly less than that found experimentally (this implies that the error estimates are indeed upper bounds). It appears that both these error sources are equally important in both the single-mode and multimode systems. The modal noise contribution in the multimode system was determined to be negligible in comparison to the error incurred from the optical modulating power variations due to experimental measurement accuracy. However, future multimode DF systems with more precise delay time and power-level measurement capabilities will have to deal with modal noise effects in order to achieve detector-limited operation. By carefully choosing the optical components of the system, the effects of modal noise can be minimized.

As a result of the fact that modal noise is not a limiting error source for the multimode matched-delay filter, a fiber choice can be made by comparing expected and experimentally observed sensitivities and dynamic ranges. Because larger optical powers can be transmitted through the multimode DF system than the single-mode system, larger dynamic ranges and greater sensitivities are possible. Therefore, on this basis the multimode DF system is considered to be the superior system.

6. AREAS OF FURTHER DEVELOPMENT

Although the results obtained in this study have been very encouraging, there are potential design and component modifications that can improve the operation and usefulness of the fiber optics matched-delay filter. For example, the operational bandwidth of the matched-delay filter is ultimately limited by the frequency response of the laser diode-optical detector combination, which in these experiments was 2 GHz. As larger bandwidth laser diodes and optical detectors become available, ultra-wideband DF systems become possible. Another fiber optic component that will enhance the operation of the matched-delay filter is an in-line variable fiber optic attenuator. These attenuators could be used to actively maintain equal modulated optical powers transmitted by each fiber delay line to a high degree of accuracy. Also, accurate fiber length-measuring techniques should be developed and used if phase errors are to be minimized. This is especially important if wider bandwidth optical fiber signal-processing devices are to be developed.

The design complexity of the matched-delay filter as diagrammed in Figure 3 can be quite substantial for even modest angular resolution requirements. Many precisely measured fiber optic delay lines are needed to simultaneously monitor different angles of arrival. For applications which do not require instantaneous azimuthal angular coverage, a scanning fiber optic DF system can be used to greatly reduce the number of fiber delay lines needed. This DF system is conceptually shown in Figure 8. By replacing the fixed length optical fibers with programmably variable fiber delay lines, an active RF direction finding system is created that can sequentially monitor different angles of arrival. This is accomplished by electrically controlling the overall delay time of each fiber channel with a single micro-processor to discretely vary the "look" angle. The critical fiber optic component in this system is the programmable fiber optic delay line. Work has recently been initiated at NOSC towards the development of this programmable fiber delay line device.

7. SUMMARY

RF direction finding with this fiber optic beamforming processor has been successfully demonstrated in the 100-2000 MHz frequency range. This fiber optic signal-processing device offers the capability of using a fixed-antenna array to simultaneously monitor the angles of arrival of multiple wideband signals. Two test model eight-laser, two-transversal filter DF devices have been designed, constructed, tested, and evaluated with favorable results. One system employs multimode fiber delay lines and the other single-mode delay lines. The frequency response of both systems were limited by the laser diode-optical detector combined response (1 GHz for the multimode system and 2 GHz for the single-mode system). The experimentally simulated angular response curves for the two systems showed good agreement, especially with respect to angular beam widths, with the calculated responses at each frequency investigated. The experimentally achieved sensitivity and electrical dynamic range for the multimode DF device was -57 dBm and 51 dB, respectively. The experimental sensitivity and dynamic range of the single-mode system was -42 dBm and 44 dB, respectively. These experimental results for both systems are close to 20 dB from the expected sensitivity and dynamic range derived assuming detector-limited operation. It was concluded that the experimentally attained sensitivity and dynamic range of both systems were limited by a combination of imprecise fiber delay times and unequal modulated optical powers contributed by each fiber. Modal noise was determined not to be a limiting noise source in the experimental multimode DF processor investigated in this study. As multimode systems with more precise control of fiber delay times and optical modulating power levels are developed, modal noise will become a more important noise source. Due to the slightly better sensitivity and dynamic range capabilities of multimode DF systems (theoretically predicted and experimentally verified), the multimode fiber optic DF processor is concluded to be the superior system. And finally, it is concluded that the fiber optics matched-delay filter can be a useful device for wideband DF.

8. ACKNOWLEDGMENTS

The author would like to express appreciation to a number of associates who have contributed technical information, ideas, and experimental support to this effort. These include C.T. Chang, M.N. McLandrich, H.E. Rast, and H.H. Caspers. A special thanks to K. Campbell and J. Silva who have financially supported this work through the NOSC Independent Exploratory Development Program.

9. REFERENCES

1. G.M. Dillard, B.R. Hunt, and H.F. Taylor, "Fiber Optics and Integrated Optics Techniques for Signal Processing," NELC TR-2013 (1977).
2. S.A. Pappert, M.N. McLandrich, and C.T. Chang, "A Fiber-Optics Matched Delay Filter for RF Direction Finding," J. Lightwave Tech. LT-3, 273 (1985).
3. S.A. Pappert, C.T. Chang, and M.N. McLandrich, "Fiber Optic Transversal Filters for RF Direction Finding," J. Fiber and Integrated Optics, Vol.6, No.1, 63 (1987).
4. S.A. Pappert, "Ultra-Wideband Direction Finding Using Fiber Optic Transversal Filters," NOSC TR-1161 (1987).
5. B. Daino, G. DeMarchis, and S. Piazzolla, "Speckle and Modal Noise in Optical Fibers: Theory and Experiment," Optical Acta 27, 1151 (1980).
6. C.B. Su, V. Lanzisera, W. Powazinik, E. Meland, R. Olshansky, and R.B. Lauer, "12.5 GHz Direct Modulation Bandwidth of Vapor Phase Regrown 1.3 μm InGaAsP Buried Heterostructure Lasers," Appl. Phys. Lett. 46, 344 (1985).
7. C. Fan and P.K.L. Yu, "High-Speed, Self-Passivated InGaAs PIN Photodiode For Microwave Fibre Links," Electron. Lett. 23, 571 (1987).

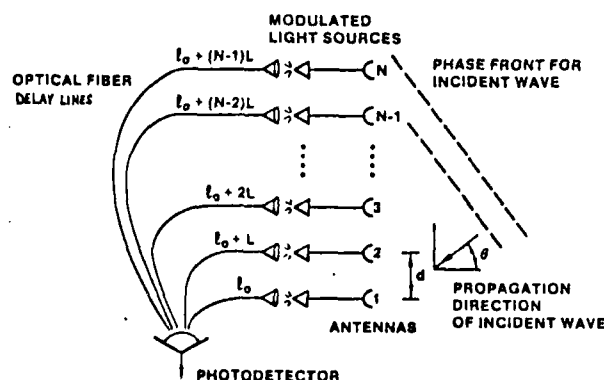

Figure 1. Single-beam fiber optic beamforming processor for RF direction finding.

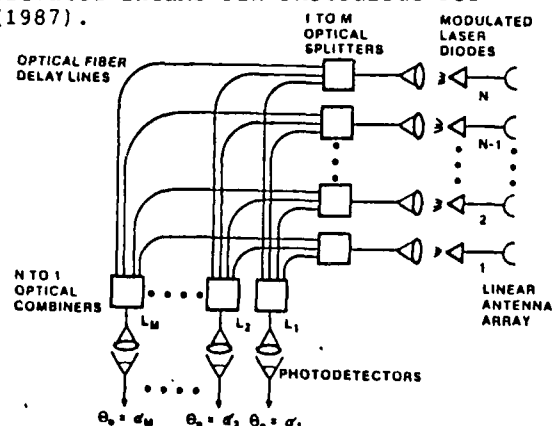

Figure 2. Multibeam DF processor that can monitor different angles of arrival.

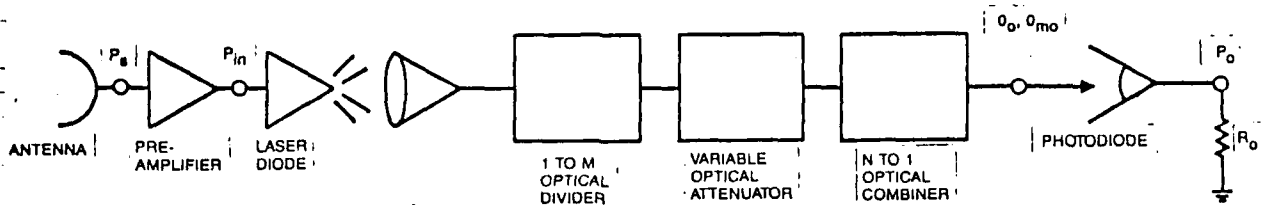

Figure 3. Received RF signal path from antenna through optical detector.

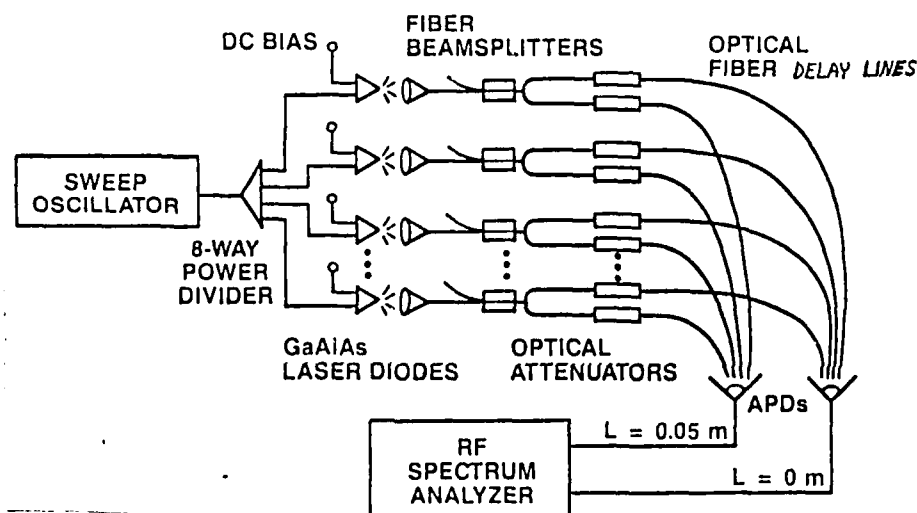

Figure 4. Experimental setup of the eight-laser, two-transversal filter DF processor. One transversal filter was constructed with an adjacent fiber length difference of $L = 0$ m and the other with $L = 0.05$ m.

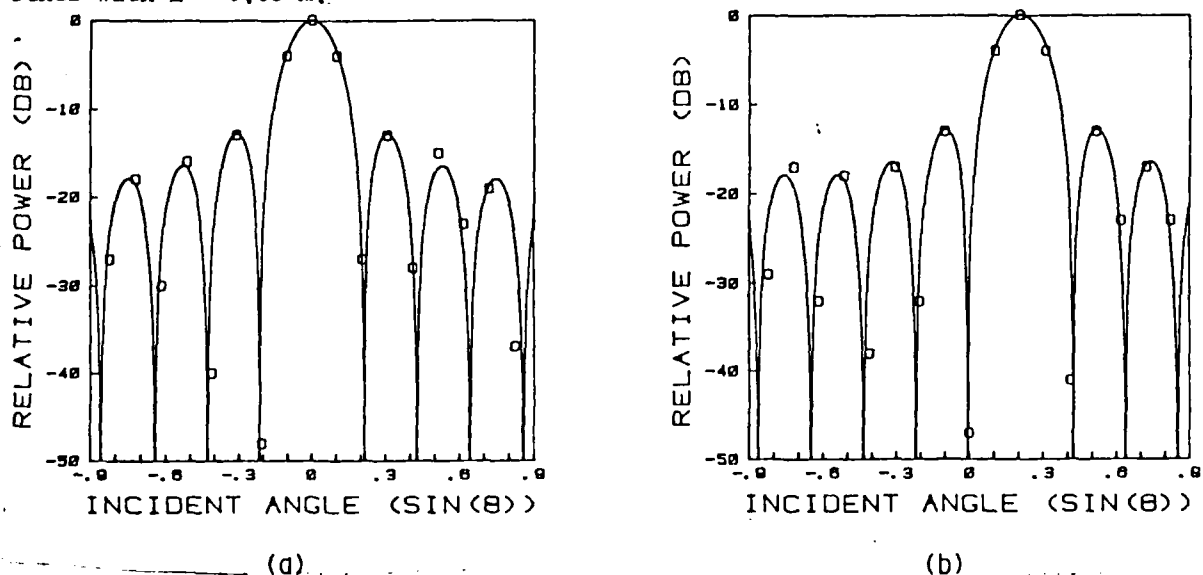

Figure 5. Experimental angular responses of the multimode matched-delay filter with $d = 0.35$ m at $f = 500$ MHz (circles) compared with the calculated responses (solid curves) for the transversal filter with (a) $L = 0$ m and (b) $L = 0.05$ m.

Start copying at bar code. Page no. 1 of 2. Page 1 of 2.

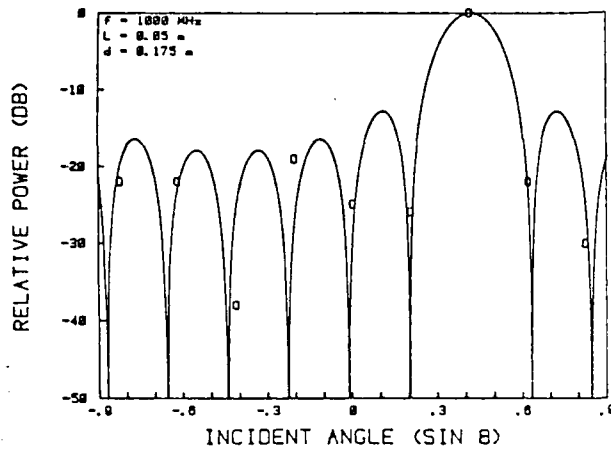

Figure 6. Experimental angular response of the single-mode matched-delay filter with $d = 0.175$ m at $f = 1000$ MHz (circles) compared with the calculated response (solid curve) for the transversal filter with $L = 0.05$ m.

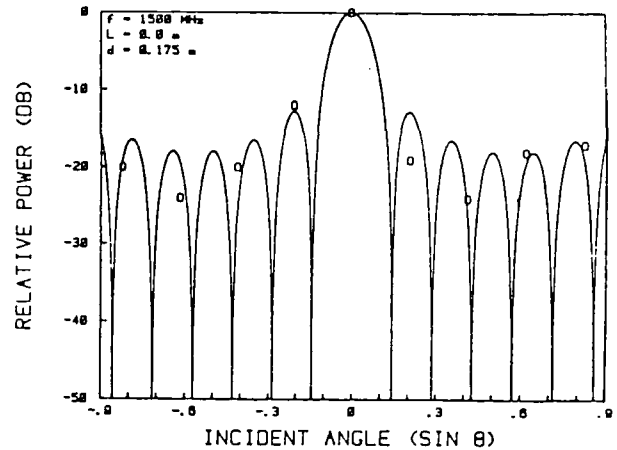

Figure 7. Experimental angular response of the single-mode DF processor with $L = 0$ m, $f = 1500$ MHz, and $d = 0.175$ m (circles) compared with the calculated response (solid curve).

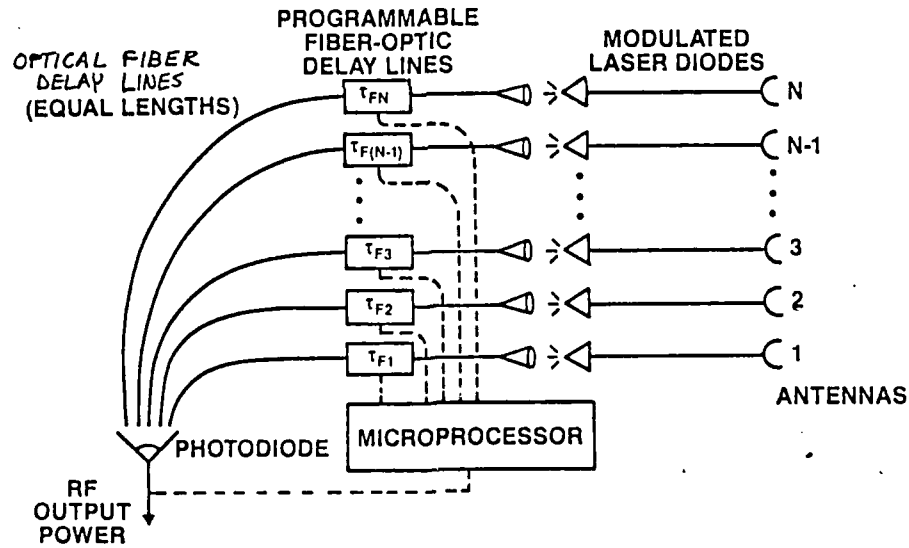

Figure 8. Scanning fiber optic direction finding system.

END

DATED

FILM

8-88

Dtic