

AD-A194 862

A FIBER OPTIC BEAMFORMING PROCESSOR FOR WIDEBAND
DIRECTION FINDING(U) NAVAL OCEAN SYSTEMS CENTER SAN
DIEGO CA S A PAPPERT APR 88

1/1

UNCLASSIFIED

F/G 17/11 NL



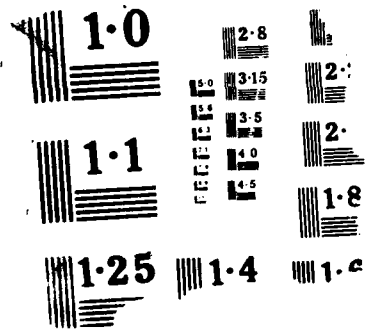

AD-A194 862

DOCUMENTATION PAGE

1a. REPORT UNCLASS		1b. RESTRICTIVE MARKINGS	
2a. SECUR		3. DISTRIBUTION/AVAILABILITY OF REPORT	
2b. DECLASSIFICATION/DOWNGRADING SCHEDULE		Approved for public release; distribution is unlimited.	
4. PERFORMING ORGANIZATION REPORT NUMBER(S)		5. MONITORING ORGANIZATION REPORT NUMBER(S)	
6a. NAME OF PERFORMING ORGANIZATION Naval Ocean Systems Center	6b. OFFICE SYMBOL (if applicable) NOSC	7a. NAME OF MONITORING ORGANIZATION Naval Ocean Systems Center	
6c. ADDRESS (City, State and ZIP Code) San Diego, California 92152-5000		7b. ADDRESS (City, State and ZIP Code) San Diego, California 92152-5000	
8a. NAME OF FUNDING/SPONSORING ORGANIZATION Director of Naval Laboratories	8b. OFFICE SYMBOL (if applicable) DNL	9. PROCUREMENT INSTRUMENT IDENTIFICATION NUMBER	
8c. ADDRESS (City, State and ZIP Code) Space and Naval Warfare Systems Command Washington, DC 20360		10. SOURCE OF FUNDING NUMBERS	
		PROGRAM ELEMENT NO. 62766N	PROJECT NO. ZE32
		TASK NO. RZ66300	AGENCY ACCESSION NO. DN305 044
11. TITLE (include Security Classification) A FIBER OPTIC BEAMFORMING PROCESSOR FOR WIDEBAND DIRECTION FINDING			
12. PERSONAL AUTHOR(S) S. A. Pappert			
13a. TYPE OF REPORT Presentation/speech	13b. TIME COVERED FROM Mar 1988 TO Mar 1988	14. DATE OF REPORT (Year, Month, Day) April 1988	15. PAGE COUNT
16. SUPPLEMENTARY NOTATION			
17. COSATI CODES		18. SUBJECT TERMS (Continue on reverse if necessary and identify by block number)	
FIELD	GROUP	fiber optics delay lines	
		signal processing devices	
		direction finding	
		optics	
19. ABSTRACT (Continue on reverse if necessary and identify by block number) This paper describes a wideband electro-optic direction finding (DF) processor employing an array of laser diodes, an array of photo-detectors, and a network of fiber optic delay lines. This DF filter offers a potential operational bandwidth in excess of 10 GHz and allows for multiple, simultaneous beam angular responses with peaks which are independent of frequency. Two eight-laser, two-beam laboratory test model DF devices, one utilizing multimode optical fiber and the other single-mode fiber, were constructed. These experimental optical beamforming filters are operable in the 100-2000 MHz frequency range and can simultaneously monitor two angles of arrival. Experiments were performed to determine the two systems' sensitivity, dynamic range, angular resolution, and frequency response. Presented at the Department of Defense Fiber Optics Conference '88, 22-25 March 1988, McLean, Virginia.			
20. DISTRIBUTION/AVAILABILITY OF ABSTRACT <input type="checkbox"/> UNCLASSIFIED/UNLIMITED <input checked="" type="checkbox"/> SAME AS RPT <input type="checkbox"/> DTIC USERS		21. ABSTRACT SECURITY CLASSIFICATION UNCLASSIFIED	
22a. NAME OF RESPONSIBLE PERSON S. A. Pappert		22b. TELEPHONE (include Area Code) 619-553-1066	22c. OFFICE SYMBOL Code 562

DTIC ELECTE
MAY 24 1988
S H D

A FIBER OPTIC BEAMFORMING PROCESSOR FOR WIDEBAND DIRECTION FINDING

Stephen A. Pappert

Electronic Material Sciences Division, Naval Ocean Systems Center
San Diego, California 92152-5000

1. ABSTRACT

This paper describes a wideband electro-optic direction finding (DF) processor employing an array of laser diodes, an array of photodetectors, and a network of fiber optic delay lines. This DF filter offers a potential operational bandwidth in excess of 10 GHz and allows for multiple, simultaneous beam angular responses with peaks which are independent of frequency. Two eight-laser, two-beam laboratory test model DF devices, one utilizing multimode optical fiber and the other single-mode fiber, were constructed. These experimental optical beamforming filters are operable in the 100-2000 MHz frequency range and can simultaneously monitor two angles of arrival. Experiments were performed to determine the two systems' sensitivity, dynamic range, angular resolution, and frequency response.

2. PRINCIPLE OF OPERATION

A schematic diagram of the fiber optic DF processor including a linear antenna array is shown in Figure 1. This system is essentially composed of many fiber optic transversal filters with each transversal filter matched to a single RF angle of arrival. This one-to-one correspondence between transversal filter and RF angle of arrival is accomplished by designing the individual transversal filters of the system with different adjacent fiber length differences. Each transversal filter will then provide the required time delay difference to compensate for only one time of arrival difference, i.e. angle of arrival, of the incoming RF signal at the antennas. Operating in the time-delay mode rather than the phase-delay mode, this DF technique yields RF arrival directions which are independent of frequency. The RF modulated optical power from each transversal filter is detected by independent high-speed photodetectors. Thus, a transversal filter with a specified adjacent fiber length difference, which is taken to be

constant, will have a peak detector response for only one RF angle of arrival. The number of independent transversal filters and laser diodes required by this system depends on the desired frequency coverage and minimum acceptable angular resolution.

The attractive features of the fiber optic beamforming processor for use in wideband DF can be summarized as follows:

- 1) it allows stationary DF platforms to be assembled that can simultaneously monitor different RF arrival angles.
- 2) it possesses a large instantaneous bandwidth (> 1 GHz).
- 3) it permits remote processing of the received RF signals yielding maximum electromagnetic interference/electromagnetic pulse (EMI/EMP) isolation.
- 4) the fiber optic components offer low cost, small size, and light weight.

3. RESULTS

To briefly summarize our results, two laboratory eight-laser, two-transversal filter DF devices have been designed, constructed, tested, and evaluated with favorable results. One system employs multimode fiber optic delay lines and the other single-mode delay lines. The experimental sensitivity and dynamic range of the multimode DF device was -57 dBm and 51 dB, respectively. The experimental sensitivity and dynamic range of the single-mode system was -42 dBm and 44 dB, respectively. These experimental results for both systems are close to 20 dB from the expected sensitivity and dynamic range derived assuming detector-limited operation. It was concluded that the experimentally attained sensitivity and dynamic

range of both systems were limited by a combination of imprecise fiber delay times and unequal modulated optical powers contributed by each fiber. Because the multimode system outperformed the single-mode system in our experiments (theoretically predicted and experimentally verified), the multimode fiber optic DF processor is concluded to be the superior system. And finally, it is concluded that this fiber optic beamforming processor can be a useful device for wideband DF.

4. RELATED REFERENCES

1. Pappert, S.A., McLandrich, M.N., Chang, C.T., "A Fiber-Optics Matched Delay Filter For RF Direction Finding," J. Lightwave Tech., vol. LT-3, No. 2, pg. 273-276, 1985.
2. Pappert, S.A., Chang, C.T., McLandrich, M.N., "Fiber Optic Transversal Filters For RF Direction Finding," J. Fiber and Integrated Optics, vol. 6, No. 1, pg. 63-77, 1987.
3. Pappert, S.A., "Ultra-Wideband Direction Finding Using A Fiber Optic Beamforming Processor," Proc. SPIE, vol. 886, Paper 29, 1988.

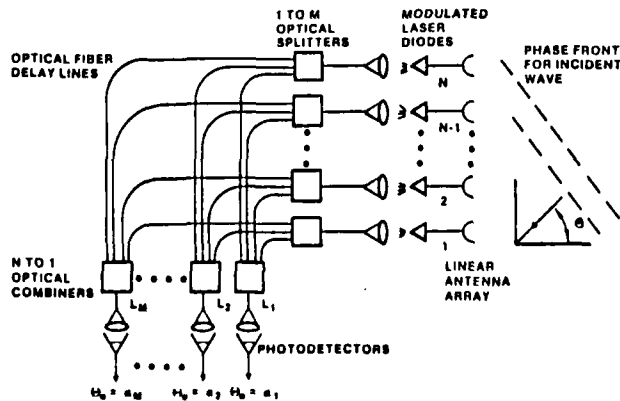

Figure 1. Multibeam fiber optic beamforming processor for RF direction finding.



Accession For	
NTIS GRA&I	<input checked="" type="checkbox"/>
DTIC TAB	<input type="checkbox"/>
Unannounced	<input type="checkbox"/>
Justification	
By	
Distribution/	
Availability Codes	
Dist	Avail and/or Special
A-1	

END

DATED

FILM

8-88

Dtic