

AD-A195 741

DTIC FILE COPY

2

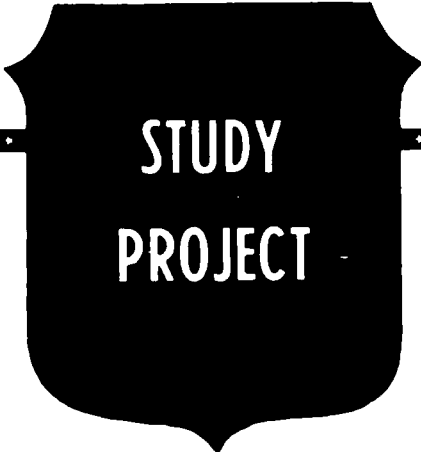

The views expressed in this paper are those of the author and do not necessarily reflect the views of the Department of Defense or any of its agencies. This document may not be released for open publication until it has been cleared by the appropriate military service or government agency.

THE ARMY OF EXCELLENCE:
AT WHAT PRICE TO COMBAT SERVICE SUPPORT?

BY

LIEUTENANT COLONEL ARTHUR P. DUPAY, AG

DISTRIBUTION STATEMENT A: Approved for public release; distribution is unlimited.

DTIC
ELECTE
S JUN 20 1988 D
CD
D

11 APRIL 1988



U.S. ARMY WAR COLLEGE, CARLISLE BARRACKS, PA 17013-5050

36 6 20 010

UNCLASSIFIED

SECURITY CLASSIFICATION OF THIS PAGE (When Data Entered)

REPORT DOCUMENTATION PAGE		READ INSTRUCTIONS BEFORE COMPLETING FORM
1. REPORT NUMBER	2. GOVT ACCESSION NO.	3. RECIPIENT'S CATALOG NUMBER
4. TITLE (and Subtitle) "THE ARMY OF EXCELLENCE: AT WHAT PRICE TO COMBAT SERVICE SUPPORT?"		5. TYPE OF REPORT & PERIOD COVERED Study Project
		6. PERFORMING ORG. REPORT NUMBER
7. AUTHOR(s) LTC Arthur P. Dupay		8. CONTRACT OR GRANT NUMBER(s)
9. PERFORMING ORGANIZATION NAME AND ADDRESS U.S. Army War College Carlisle Barracks, PA 17013-5050		10. PROGRAM ELEMENT, PROJECT, TASK AREA & WORK UNIT NUMBERS
11. CONTROLLING OFFICE NAME AND ADDRESS Same		12. REPORT DATE 11 April 1988
		13. NUMBER OF PAGES 55
14. MONITORING AGENCY NAME & ADDRESS (If different from Controlling Office)		15. SECURITY CLASS. (of this report) UNCLASSIFIED
		15a. DECLASSIFICATION/DOWNGRADING SCHEDULE
16. DISTRIBUTION STATEMENT (of this Report) Approved for public release; distribution is unlimited.		
17. DISTRIBUTION STATEMENT (of the abstract entered in Block 20, if different from Report)		
18. SUPPLEMENTARY NOTES		
19. KEY WORDS (Continue on reverse side if necessary and identify by block number)		
20. ABSTRACT (Continue on reverse side if necessary and identify by block number) In 1983, the Army embarked on a plan to redesign, then restructure, and then reorganize the entire tactical Army in support of Airland Battle doctrine. This plan was called the Army of Excellence. Designers of this new 28 division Army force point with pride to units which focus their resources on combat capability. The Army of Excellence also gives a corps structure with greater capabilities in artillery, aviation, and air defense which expanded the ability to influence the Airland Battle. It created light infantry (continued)		

DD FORM 1473

1 JAN 73

EDITION OF 1 NOV 65 IS OBSOLETE

UNCLASSIFIED

SECURITY CLASSIFICATION OF THIS PAGE (When Data Entered)

ABSTRACT--Continued.

divisions, with enhanced deployment capability. Finally, it eliminated the "hollowness" which had existed. The Army of Excellence did all of this without the addition of a single space in the active force and only moderate growth in the Reserve Components. There were two major trade-offs to achieve such a force. The first is a refinement in combat service support structure and the second is the expanded willingness to accept risk. This study seeks to examine the changes and impact which the Army of Excellence has brought to combat service support. It will examine the combat service support structure at all levels and within all components. It will make some assessments based on revisions to programmed end strength, the delayed fielding of many logistics unit improvements, and the ability of the divisions, with emphasis on the light infantry divisions, to conduct operations without significant augmentation. This study is a status report on one aspect of the Army of Excellence. It does not attempt to make recommendations for further changes to the total force.

UNCLASSIFIED

USAWC MILITARY STUDIES PROGRAM PAPER

The views expressed in this paper are those of the author and do not necessarily reflect the views of the Department of Defense or any of its agencies. This document may not be released for open publication until it has been cleared by the appropriate military service or government agency.

THE ARMY OF EXCELLENCE:
AT WHAT PRICE TO COMBAT SERVICE SUPPORT?

AN INDIVIDUAL STUDY PROJECT

by

Lieutenant Colonel Arthur P. Dupay, AG

Colonel L. D. Hardy, Jr.
Project Advisor



DISTRIBUTION STATEMENT A: Approved for public release; distribution is unlimited.

U.S. Army War College
Carlisle Barracks, Pennsylvania 17013
11 April 1988

Accession For	
NTIS CRA&I	<input checked="" type="checkbox"/>
DTIC TAB	<input type="checkbox"/>
Unannounced	<input type="checkbox"/>
Justification	
By _____	
Distribution /	
Availability Codes	
Dist	Availability Codes
A-1	

UNCLASSIFIED

ABSTRACT

AUTHOR: Arthur P. Dupay. LTC, AG

TITLE: The Army of Excellence: At What Price to Combat Service Support?

FORMAT: Individual Study Project

DATE: 11 April 1988 PAGES: 52 CLASSIFICATION: Unclassified

△ In 1983, the Army embarked on a plan to redesign, then restructure, and then reorganize the entire tactical Army in support of Airland Battle doctrine. This plan was called the Army of Excellence. Designers of this new 28 division Army force point with pride to units which focus their resources on combat capability. The Army of Excellence also gives a corps structure with greater capabilities in artillery, aviation, and air defense which expanded the ability to influence the Airland Battle. It created light infantry divisions, with enhanced deployment capability. Finally, it eliminated the "hollowness" which had existed. The Army of Excellence did all of this without the addition of a single space in the active force and only moderate growth in the Reserve Components. There were two major trade-offs to achieve such a force. The first is a refinement in combat service support structure and the second is the expanded willingness to accept risk. This study seeks to examine the changes and impact which the Army of Excellence has brought to combat service support. It will examine the combat service support structure at all levels and within all components. It will make some assessments based on revisions to programmed end strength, the delayed fielding of many logistics unit improvements, and the ability of the divisions, with emphasis on the light infantry divisions, to conduct operations without significant augmentation. This study is a status report on one aspect of the Army of Excellence. It does not attempt to make recommendations for further changes to the total force. (SNA.)

TABLE OF CONTENTS

	Page
ABSTRACT.	ii
CHAPTER I. INTRODUCTION.	1
II. THE ARMY OF EXCELLENCE.	4
The Hollow Force.	4
AOE Guidance.	5
End Strength and Balance.	8
III. AOE METHODOLOGY	11
Definition.	11
Division Design	11
Division Force Equivalent	13
The Trade Off	15
IV. THE AOE HEAVY DIVISION.	18
Division Base	18
Division Support Command.	20
V. THE AOE CORPS and ECHELONS ABOVE CORPS.	23
Logistics Unit Productivity Study	23
The ALO 1 Corps	25
Examples.	26
VI. THE AOE LIGHT INFANTRY DIVISION	28
Guidance.	28
Operational Concept	31
Deployment.	33
VII. CONCLUSIONS	40
Heavy Divisions	40
Corps/Echelons Above Corps.	41
Light Divisions	42
General CSS Issues.	45
BIBLIOGRAPHY.	47
APPENDIX 1.	A-1

THE ARMY OF EXCELLENCE:
AT WHAT PRICE TO COMBAT SERVICE SUPPORT?

CHAPTER I

INTRODUCTION

"Army leadership is convinced, based upon careful examination of studies which postulate the kind of world in which we will be living and the nature of conflict we can expect to face, that an important need exists for highly trained, rapidly deployable light forces." When the Army Chief of Staff published his White Paper¹ in April 1984 with these words, the decision to form light infantry divisions and increase the size of the total force from 24 to 28 divisions was made. These actions came during the period of an extensive modernization effort and a renewed commitment to defense from the President, the Congress, and the American people.

This paper will address two of the significant issues of this grand plan. The first issue is that of the light infantry division and its capability to conduct combat operations given the austere combat service support structure allocated to the

organization. Secondly, this paper will focus on the combat service support structure in the total Army of Excellence and examine the direction in which the tooth-to-tail ratio has gone, and at what cost.

There are many officers in the force today who do not yet understand the full scope of the Army of Excellence initiatives. Questions are continually being asked why so many light divisions are needed and how long can the Army continue to justify its current combat structure in view of forced end strength reductions. Nevertheless, the almost irreversible process of organizing, equipping, and stationing four light infantry divisions goes on. The heavy divisions, decremented by 3,000 spaces, are working hard to accomplish missions which did not decrease in a corresponding level to the authorizations. Finally, the logistics and personnel community continue to wait, and compete for the scarce dollars necessary to field the technological breakthroughs which will provide the capability to do more with less.²

Has the Army really eliminated the hollowness of the Division 86 force and if so has the cost been to the combat service support structure? Army of Excellence briefing data points out the 28 division force is designed for the actual threat. Time will soon tell whether we have a proper warfighting force or simply reassigned the risk?

ENDNOTES

1. John A. Wickham Jr., General, "Light Infantry Divisions - White Paper 1984, (Washington, D.C.: Department of the Army, 1984), p.4.

2. There are still a considerable number of officers who have frustrations understanding decisions of the AOE study and implementation. I am among them. Readers may find objection in the tone of certain statements of this study. Accept these as the personal bias of the author, who in no way is questioning the professional abilities, judgment, or integrity of anyone involved in the AOE process.

CHAPTER II

THE ARMY OF EXCELLENCE

The Hollow Force

In 1983, the term Army of Excellence (AOE) was introduced to the force. It found substance in the implementation of the Army of Excellence Study recommendations which significantly changed the Army force structure and doctrine. The study was commissioned by the then, new Army Chief of Staff, General John A. Wickham Jr. The Army leadership had become increasingly aware that much of the Army had evolved, during the 1970s, into a "hollow" force. The hollowness was manifested in several forms. In one case, forces were composed of units assigned multiple missions. Since the missions could occur simultaneously in different theaters, some forces would be short the necessary units to effectively execute their plans. In another form, the required number of units was placed in the force structure; however, manpower constraints dictated they be manned at a greatly reduced level, and in some instances existed solely on paper.

The Army's leadership was also concerned with the ability to rapidly react to crises. The lessons learned from the

Falklands and Grenada indicated that strategic mobility was, at times, far more essential than the fire power and total capabilities of heavy maneuver forces in a given theater. The 1983 forces were large, flexible, and powerful when operating on a battlefield, but getting to the battlefield could too often be slow or impossible. The Chief of Staff identified the need for a fighter-heavy, more deployable force.

General Wickham believed the Army's composition and capabilities reflected the commitments of the past. As the focus shifted away from Vietnam to the armored and mechanized battlefields of NATO, the structure became heavier to confront the Soviet heavy threat. However, against this backdrop of heavy forces, the actual nature of conflict since World War II has been mid to low intensity. General Wickham further believed that forces with great flexibility were required to respond to these types of crises, while still maintaining the capability to deal with the more dangerous NATO contingency.¹

AOE Guidance

The U.S. Army Training and Doctrine Command (TRADOC) was tasked to conduct a feasibility study which addressed the leadership's concerns (hollowness and strategic deployability)

and provide recommendations in late 1983. The Army Staff provided the following points of guidance:²

- The recommended designs would not exceed the Army's programmed personnel end strength. (Fiscal Year 1989 figures were programmed at 780,900 for the Active Army, 464,900 for the Army National Guard (ARNG), and 339,100 for the U.S. Army Reserve (USAR). (Planners could assume some modest growth in the Reserve Components not to exceed a combined total of 817,000.)

- Determine whether the Army can be manned at Authorized Level of Organization (ALO) 2. (This equates to filling a unit with the personnel and equipment to 90 percent of its required wartime strength.)

- Develop a proposal for a light, division-size force optimized for rapid deployment for contingency missions. (The Chief of Staff also wanted a division force that could be deployed using not more than 500 C-141 sorties.)

- Recommend reductions to the end strength of heavy divisions that will increase maneuverability of the organizations. In the recommendations, consideration should be given to centralizing assets at echelons above division (EAD).

- Redesign corps and echelons above corps (EAC) to improve their warfighting capability.

There are now many officers who argue that TRADOC was given an impossible task. Not only did they have but 90 days in which to make good all the shortcomings of Division 86, an organization which took six years to design, but they were given most of the answers along with the problem.³ Consequently, the critical elements essential to properly use the Concept Based Requirements System (CBRS) and Mission Area Analysis (MAA) were modified. The CBRS is a system by which concepts are developed and analyzed and from which doctrinal, organizational, training and materiel needs for the Army evolve. Once the concepts are approved they become input to the MAA, which is essentially an extensive assessment of force capability within a particular battlefield mission area, e.g., close combat (heavy and light), command and control (C²), combat service support (CSS), a total of 13, with the TRADOC integrating centers and schools serving as proponents.⁴

In the final AOE report, TRADOC states that the CBRS methodology was compressed and accelerated. TRADOC maintains that all concepts were reviewed to ensure compliance with doctrine, and then served as the basis for the development of design criteria. The MAA proponents took the concepts and design criteria and developed proposed organizations that met the conceptual requirements. In fact, it has been impossible to find any documents associated with the AOE Study which explain the current mix of the 28 division force.⁵

End Strength and Balance

Despite the assertion that doctrine and threat drove the change, the primary reason that the AOE study was undertaken was because the "sum of the Army's required parts exceeded the resources available to structure the Army".⁶ Regardless of the outcome generated by sophisticated computer models, the requirements of the warfighting CINCs (Commander-in-Chief), and the knowledge and expertise of those involved in the study, the final product was driven as much by the end strength issue as anything else.

Here it is of interest to note that in the early part of the Reagan Administration, the Army made plans to take advantage of the growing support to the defense establishment by proposing to expand the active force to 870,000 by 1989. The 870,000 plan contained proposals which would have allowed for the formation of new light divisions.⁷ However, the Army accepted a no end strength growth based on the need to maintain the modernization initiative and protect the "people programs". Consequently, for the past several years the Army has continued to operate within the 781,000 end strength constraint.

Another perception which had significant impact on the TRADOC study was the notion that, over time, the Army had gotten

out of balance among combat, combat support (CS), and combat service support (CSS) structure. Despite the fact that less than two years before AOE Army leaders were stating that the number-one manpower shortfall was CSS structure⁸ we shall soon see that this was the one of the primary bill payers for adding two light divisions.

The final driving point of the AOE study was the focus on doctrine. The focus of our Airland Battle doctrine has shifted from brigade and division level to corps. Therefore, many of the AOE initiatives, particularly those with regard to CS and CSS issues, are found at corps or EAC levels.

ENDNOTES

1. Wickham, p.5.
2. U.S. Department of the Army, Field Circular 100-1, The Army of Excellence, (Fort Levenworth, 1984), Volume I, p. 1-3.
3. Ibid. A review of the guidance will show that decisions regarding light divisions, size of heavy divisions, and staffing levels were made prior to a Concept Based Requirements System (CBRS) determination of need.
4. U.S. Army War College, Army Command Management: Theory and Practice, (Carlisle Barracks, 1987), p. 11-1.
5. Contact with Combined Arms Center and HQDA (DSCOPS) failed to produce documents relating to the division mix of the AOE. Certainly there must be a documented rationale and it is undoubtedly contained in documents (perhaps classified) beyond the level of research undertaken in this study.
6. Field Circular 100-1, p. 1-3.
7. Robert S. Rush, "Comparing Light Divisions", Military Review, LXVIII, (January 1987), p. 63.
8. Sam Damon and Ben Krisler (Pseudonyms), "Army of Excellence? A Time to Take Stock", Armed Forces Journal, (May 1985), p. 88.

CHAPTER III

AOE METHODOLOGY

Definition

Before taking a closer look at the light divisions and CSS capabilities, a discussion on how the AOE was developed is appropriate. Let's start by defining AOE. It was and remains a plan. It is a plan to redesign, then restructure, and then reorganize the entire tactical Army in support of Airland Battle doctrine, within a constrained resource environment. Not a small task under any circumstances, but given a 90-day time period in which it was accomplished, it represents one of the most significant force development actions ever undertaken.

Division Design

Because the corps and EAC are composed of divisions and the elements needed to support divisions, the various division designs were the first step.

The effort began with the design of the Light Infantry Division (LID). Most of the elements of the LID were developed

from the ground up and required a major revision in the way combat, CS, and CSS forces operate. Included in this portion of the study was an examination of the feasibility and desirability of standardizing all light forces in the Army.

The next step was the redesign of the Army's heavy forces. It was essentially an evolution of the Division 86 development process. Using the heavy Division 86 as a point of departure, the goal was to reduce authorizations and still maintain combat capability. However, reductions could not be imposed without some corresponding reduction in capability.

Proposed decrements to the heavy division sliced almost 16 percent of the personnel along with significant amounts of materiel. Whenever possible, the decrements were made in CS and CSS areas in order to maintain combat power. Lessons learned from the Logistics Unit Productivity Study (LUPS) were considered in the redesign of the division's support command (DISCOM). Efforts were made to increase unit productivity while improving the efficiency of the organization.

The functions and capabilities that will always be needed by a division were made organic in the design. To accommodate the occasionally used assets, an augmentation concept was used that placed specific capabilities in the division's parent corps' structure. The theory being, that the augmenting organization will be able to "plug" in as the situation dictates.

The most challenging task was to develop the corps and EAC for each theater. TRADOC had previously completed a study of the heavy and light corps and this was used as the baseline in the AOE study.¹ In the AOE corps more stringent and austere workload factors and allocation rules were imposed.² Personnel authorizations were established with a priority given to increasing overall combat capability and accepting a greater risk in the support functions. Given the 781,00 ceiling, if an addition was made to a theater or functional area, a corresponding decrease in authorization was made from elsewhere within the structure.

Division Force Equivalent

What special magic was used to find the spaces for the new divisions? TRADOC choose to use the Division Forces Equivalent (DFE) methodology to grow the AOE force to 28 divisions and live within the end strength constraints (AC, 781 K + RC, 817 K = Total, 1,598 K). The DFE is a mathematical expression of the combat, CS, and CSS within the Army, divisible by the number of divisions. The DFE consists of three increments: the division increment, which consists of the total division and its organic parts; the nondivisional combat increment (NDCI), wherein are found armored cavalry regiments, corps artillery, engineer, and attack helicopters; and the tactical support increments (TSI)

which generally corresponds to the CSS, signal, military police, and military intelligence units supporting the force.

The Army 86 force³ was laid down as follows in the DFE methodology:

	DIVISIONAL INCREMENT	+ NONDIVISIONAL INCREMENT	+ TACTICAL SPT INCREMENT	= CBT FORCE
Army 86	16 K	12 K	20 K	48 K
24 Div Force	384 K	288 K	480 K	1.152 K

The AOE allocation⁴ turned out a DFE which was 10,750 spaces less than the Army 86 model. Constraints imposed by the initial guidance, productivity enhancements, and risk acceptance all contributed to this lower figure.

AOE	15.1 K	8.3 K	13.8 K	37.25 K
28 Div Force	422 K	233 K	387 K	1.043 K

Equally significant in the requirement verses structure issue, is the significant changes in the use of COMPO 4 and ALO 2

through 10 staffing in the AOE organization. Component 1, commonly referred to as COMPO 1, is the Active Army, COMPO 2 is the ARNG, COMPO 3 is the USAR, and COMPO 4 is unresourced structure that is required TO&E organizations with no personnel or equipment allocated. Under Army 86, in order to build the required 24 division force, there were units in each increment staffed anywhere from ALO 1 through ALO 10 and in all four components. The AOE produced a plan that had all divisions at ALO 1, except for the 2d Infantry Division, which by deliberate choice was staffed at ALO 2. The NDCI and the TSI were to be maintained at ALO 2. Equally significant was the fact that no COMPO 4 units were added to the AOE design and the total number of COMPO 4 requirements decreased.⁵

The Trade Off

In order to achieve this, AOE has to accept considerable trade off. Although the structure was to be maintained at a high ALO in COMPO 1, 2, and 3, not all missions could be met. To make the model work for the entire AOE design, or any one of the parts, such factors as host nation support, contract labor and services, and a quantified risk had to be worked into the equation.

When all the absolutes were made part of the package it began to bulge. In order to stay within the given numbers, and comply with mandates to create two new divisions, increase tooth-

to-tail ratio, create an ALO 1 combat force, and increase leader-to-led ratios, the bill payers had to be found.

There is a perception that the Army of Excellence and its new divisions were resourced at the expense of combat service support. During the remainder of this paper we will look at what has happened to CSS structure and will examine the major changes AOE has given us. The primary focus will center on the light infantry division and its CSS capabilities.

Before going into details of the LID and its sustainment capabilities, a brief review of what happened to the CSS structure at the heavy divisions, corps, and EAC is necessary.

ENDNOTES

1. Briefing notes accompanying Combined Arms Center Briefing titled, Force Structure and Design Initiatives for an Army of Excellence. Also, Field Circular 100-1, p. 1-5.
2. Ibid.
3. Briefing slides for Combined Arms Center Briefing titled, Force Structure and Design Initiatives for an Army of Excellence.
4. Ibid.
5. Review of Personnel and Structure and Composition System Reports (PERSACS) reports from FY 84 projected to FY 92.

CHAPTER IV

THE AOE HEAVY DIVISION

The Division Base

Prior to AOE, the heavy divisions tipped the scales at 19,451 authorized (a base armored division in the Division 86 design). In the three month AOE study process a new organization was drawn up which decremented the division by 3,000 spaces, down to 16,530.¹ See figure 1 for comparison. A significant portion of the reduction came in the transfer of the Chaparral air defense system and 8" artillery to corps. By moving these units, system unique CSS could also be decreased. Additional spaces were given up by proponents who were told to reduce robustness and redundancy (R²) which had been initially designed into the system. Concepts such as area support rather than direct support, providing the capability for personnel to perform two or more functions, and the institution of area field feeding resulted in the most significant space reductions.

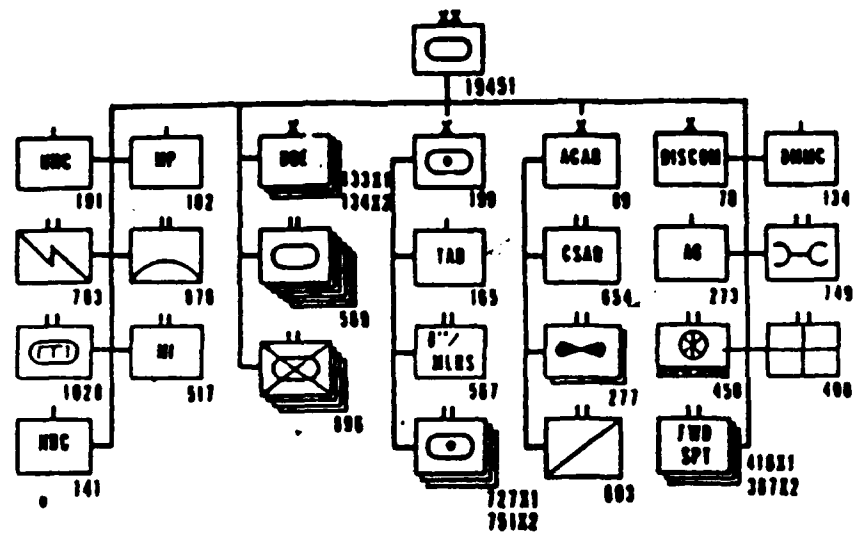

DIVISION 86 Design

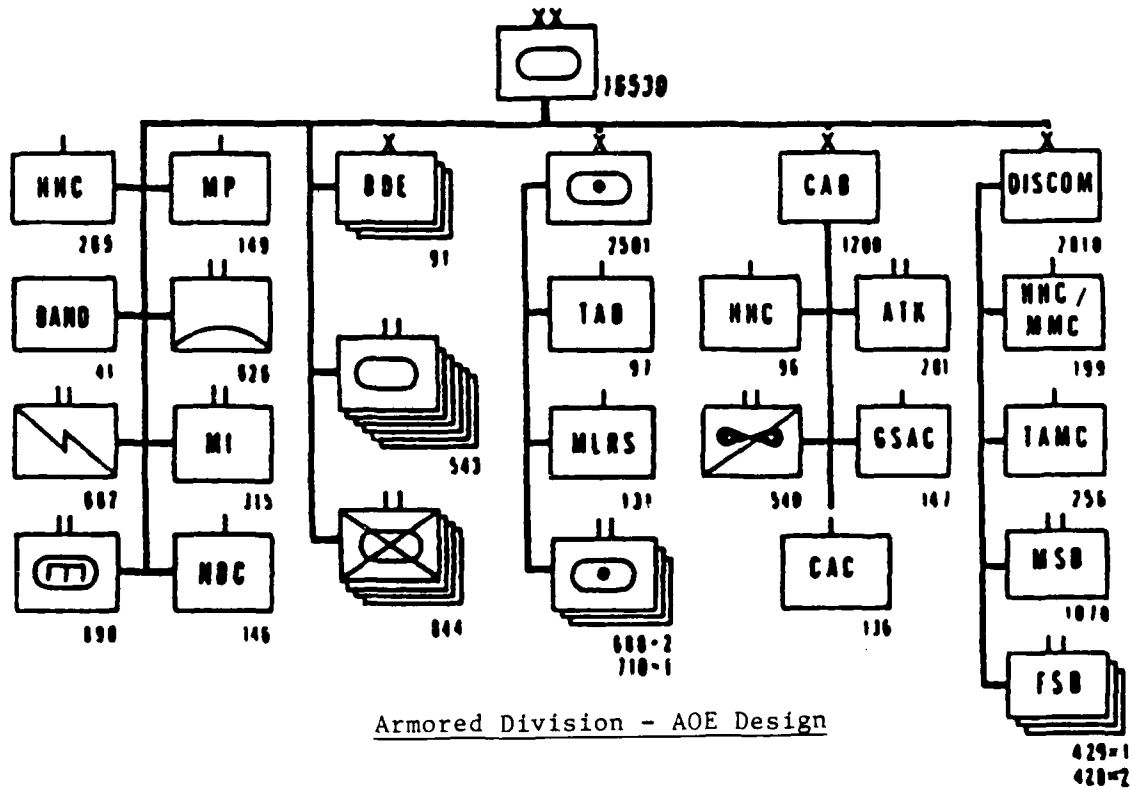

Armored Division - AOE Design

Figure 1

The Division Support Command

The armored DISCOM was reduced in size from 3,325 to 2,810, while at the same time gaining a 256 man aviation maintenance company previously in the aviation brigade. This equates to a net loss of 771 spaces to CSS structure, or 23 percent of the previous authorization.² To achieve this reduction all direct support (DS) maintenance, less military intelligence and signal, was consolidated within DISCOM. The major space savings came from elimination of supply and transport (S&T), medical, and maintenance battalions and placing some of those assets in a main support battalion (MSB). The DISCOM Headquarters and Headquarters Company (HHC) and the Division Materiel Management Center (DMMC) were consolidated. Most Adjutant General and finance functions were transferred to corps level. A reduced component repair capability was accepted by an increased reliance on direct exchange. This final point is somewhat offset by the transfer of unique weapons systems to corps which lowered support requirements. Although certain economies were realized with the consolidation of CSS functions into a MSB, much of the support structure given up was simply assigned to corps and given the mission to provide direct or general support to the division, e.g., AG, finance, heavy vehicle transport, and selected maintenance functions. See figure 2 for comparison of heavy division service support structure.

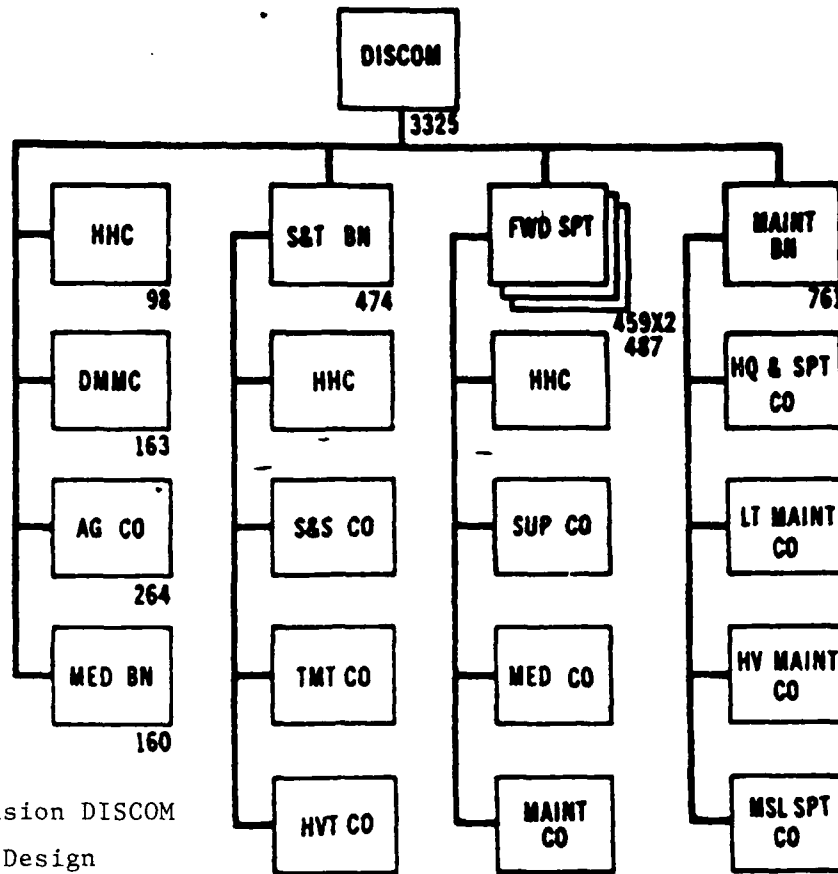

Armored Division DISCOM
Division 86 Design

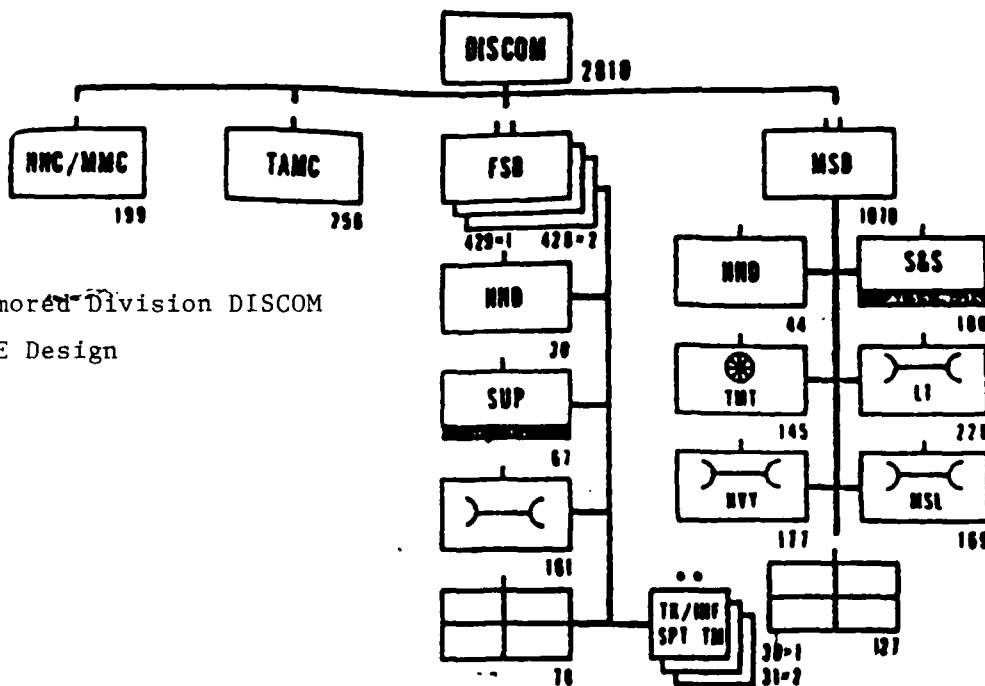

Armored Division DISCOM
AOE Design

Figure 2

ENDNOTES

1. Field Circular 100-1, Volume III, pp. 3-4.
2. Field Circular 100-1, Volume I, pp. 3-1 to 3-4.

CHAPTER V

THE ARMY OF EXCELLENCE CORPS and ECHELONS ABOVE CORPS CSS STRUCTURE

The corps and theater levels are where the AOE had the greatest impact on service support structure. The techniques used within the divisions, such as area field feeding, reliance on automation, elimination of R², and a greater emphasis on replacement components rather than repair were repeated. However, the biggest single space saver in the AOE was a redesign of almost all CSS driven by the Logistics Unit Productivity Study (LUPS).

Logistics Unit Productivity Study

LUPS was initiated by the Logistics Center at Fort Lee in 1983 and was jointly sponsored by the Transportation, Quartermaster, and Ordnance Schools. It was a plan to reduce authorizations in the combat service support arena, while at the

same time becoming more productive. The key was to improve the reliability, availability, maintainability, and durability of equipment; reduce weight, volume and manpower requirements; and improve logistics unit and systems productivity and throughput. Specific issues such as the palletized loading system (PLS), automated pipeline construction system, robotic refueling systems, and expert diagnostic systems¹ were just some of the reasons the logistics community assumed the "can do" attitude and handed over more than 15,000 active spaces² for AOE initiatives.

On the basis of technology, almost all of which is still within the research, development, test, and evaluation process, or only barely passed the first unit equipped stage, tremendous manpower saving have been projected. The Logistics Center stresses that AOE force structure and logistics initiatives have improved sustainability. Redesign of transportation, maintenance, field services, and supply units in all components based on LUPS reduced the stated CSS shortfall from 342,000 in Fiscal Year (FY) 90, to 194,000 in FY 91, to 151,000 in FY 92.³ These figures and the issue of improved sustainability have yet to be proven by any valid measure or test. Nevertheless, shortfalls still exist in direct and general support (DS and GS) maintenance, cargo movement, ammo services and supply, bridging and construction, and medical services.⁴

The ALO 1 Corps

What follows is an example how you can give up spaces and grow at the same time. Prior to AOE the five corps support commands (COSCOM) had approximately 180,000 spaces of structure. A total of 42,000 were unresourced and found in COMPO 4. Those remaining were heavily weighted in the Reserve Components and generally filled to ALO 3. Under AOE, the five COSCOMs are to have approximately 145,000 spaces, with all being resourced and staffed at ALO 1.⁵ The numbers will fluctuate as refinements are made, but such basic rules as no competing missions, and no additional COMPO 4 will remain.

As CSS organizations moved to corps level, from division or out of COMPO 4 into the resourced components, they got smaller. LUPS and the end strength issue were the major influences. This initiative resulted in the Army's five COSCOMs being organized with 145,000 authorized spaces. Compare this to the previous 180,000 structure required for the same five COSCOM organizations. Because of hollowness these 180,000 spaces could only be filled to the 111,000 level. At the corps level a gain of 35,000 soldiers in CSS structure appears exactly what was needed. However, remember that most of the spaces were transferred from the divisions. In actual spaces there is, in general, a zero sum gain. Productivity enhancement, as the basis for mission accomplishment, remains the critical element of this equation.

Examples

Here is one example of a space saving. Supply companies (heavy materiel, DS and GS) were reduced in number from 115 to 101. 7,483 spaces were given up in this process. However, this is not cause for alarm. LUPS says the heavy materiel units improve productivity from 765 to 1,400 short tons (ST) per day, the DS units improve their support capability from 8-15,000 soldiers to 18,000, and the GS units increase from 460 to 467 ST per day.⁶ New trucks, a PLS, paperless electronic supply, and improved maintenance and transportation management systems are all that are needed to make this a reality.

Another example is the terminal transfer company which has the mission of transferring cargo from one mode to another. New LUPS equipment for these units will reduce Army-wide requirements by 6,300 spaces. All that is needed is \$45 million for a rough terrain container crane and better forklifts and trucks.⁷

Many of these grand designs have been made by combat developers based on assumptions of continued growth in the defense budget on a par with FY 81 - 83. The past four years have, in fact, seen less growth and more belt tightening. The consequences may well have put us right back into the hollow structure AOE was designed to prevent.

ENDNOTES

1. Michael R. Gordon, "Light Doesn't Mean Easy", *Military Logistian*, Volume I, (May 1985), p. 31.
2. Department of the Army, "Combat Service Support", Discussion Paper prepared for Congressional Briefing Book, (DCSOPS, August 1986).
3. Department of the Army, "Total Force Sustainability", Discussion Paper prepared for Congressional Briefing Book, (DCSOPS, June 1986).
4. Breifing notes for CAC briefing on AOE.
5. Jim Tice, "Program to Cut Combat Service Support Manning by 12,500", *Army Times*, (23 November 1987), pp. 16-18.
6. John A. Wickham Jr., General, "U.S. Army Light Divisions", A Report to the Seneate Armed Services Committee, (Washington, D.C.: Department of the Army, 1984).

CHAPTER VI

THE ARMY OF EXCELLENCE LIGHT INFANTRY DIVISION

Guidance

The Chief of Staff gave the following guidance¹ to those involved in building a light division:

- Division to contain about 10,000 soldiers.
- Nine maneuver battalions.
- Deployable in 400-500 aircraft sorties.
- One half of the division will be infantry.

As with the total AOE study, the CBRS and the Battlefield Development Plan processes were significantly altered in the light division analysis. The need was established by the August 1983 Army Commander's Conference and so directed by General Wickham. Proponents were told to produce lean, austere organizations using the following design objectives:

- Commonality of supplies, equipment, and structure.

- Reduce noncombat soldiers and overhead to a minimum.
- Minimize support requirements.
- Identify plugs of augmenting units.
- Support systems to be compatible with foot-mobility.

The design of the LID was put together based on these, and several other concepts, approved and scheduled for implementation in five units. The 7th and 25th Infantry Divisions have converted to the new design. The 6th and the 10th Divisions in the active force, and the 29th Division in the ARNG will be formed and organized as light infantry. See figure 3 for LID organization diagram.

General Wickham was convinced that reorganization of combat forces were necessary and that the LID was an essential part of the new force. He said this about the Light Infantry Division in his special report to the Senate Armed Services Committee. "Light infantry divisions add an important new dimension to the national strategy of deterring conflict. When directed by the National Command Authorities, the light infantry divisions can deploy by air throughout the world and gain surprise by virtue of their excellent strategic mobility. Having gained surprise, the light infantry divisions can establish an airhead and begin to secure a lodgment for follow-on forces. The Army added light infantry divisions to its structure because of the increased

LIGHT INFANTRY DIVISION

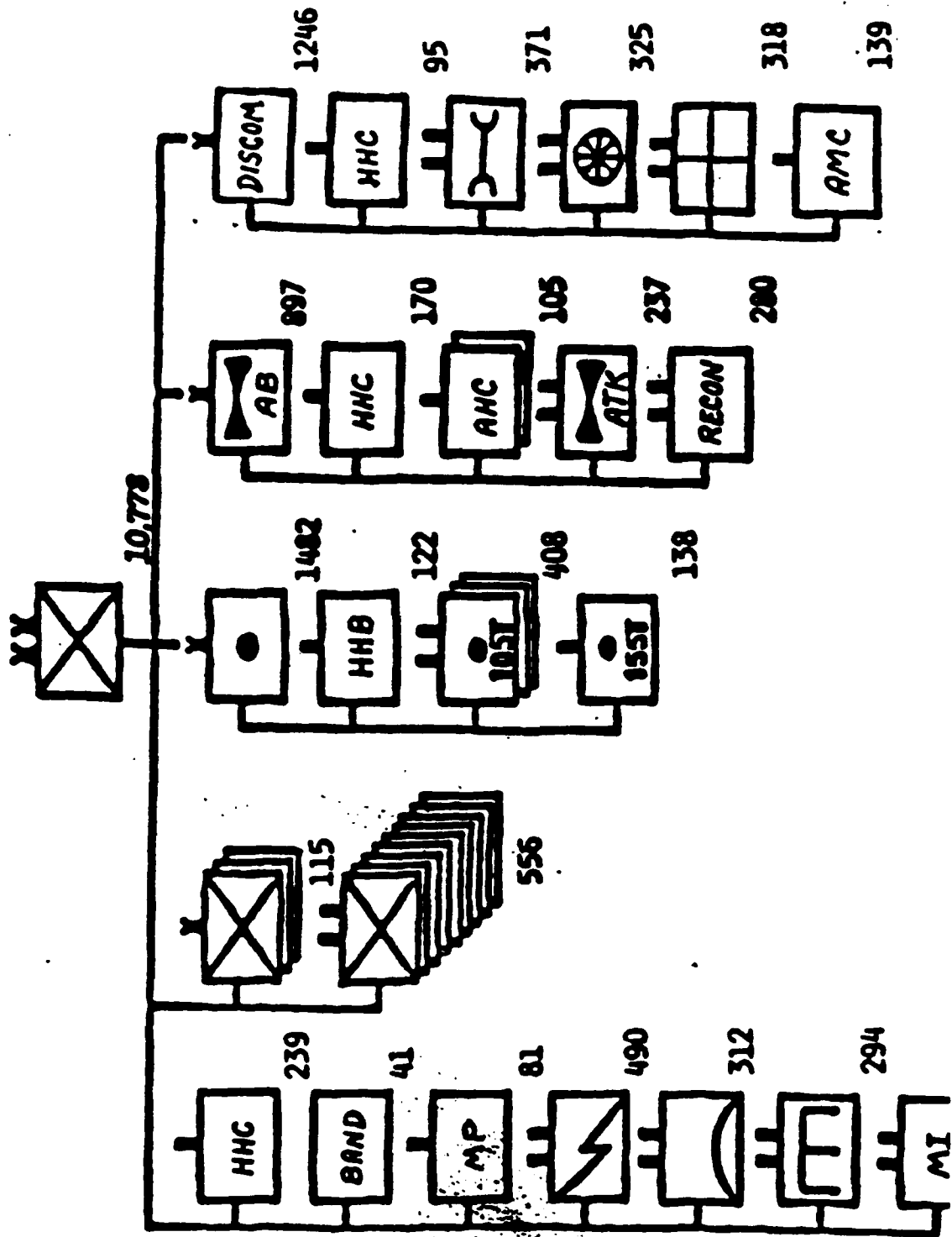

Figure 3

likelihood of low intensity threats to United States' interests throughout the world. To counter these low intensity threats, the Army designed the light infantry division to be its most strategically-mobile division and with more than one third foxhole strength."²

Operational Concept

The operational concept for the division calls for a small, flexible, and versatile fighting force capable of responding quickly to crisis situations. The division is organized for rapid deployment, immediate combat operations upon arrival in any conflict environment, and quick retrieval from the operational area after the mission is completed. The division is composed primarily of fighters equipped with lightweight weapons systems which are supposed to be sustained by an austere support structure. The division was designed to capitalize on technological advances to enhance its performance and reduce the manpower required to perform essential battlefield tasks.

Combat service support is limited to minimum essential assets for operations in contingency areas. The division is capable of operating for 48 hours without resupply and can conduct only limited resupply for its maneuver forces with organic assets.³ Personnel and field services are especially austere. While organic combat support and service support are

limited, the division is designed to accept augmentation readily by other forces.

The revised concepts under which the light infantry division CSS was designed are summarized as follows:⁴

- Supply. Field feeding using meals ready-to-eat and T-rations. Prepackaged clothing. POL to be throughput from EAD. This is an immediate requirement for corps support not counted in the division or possible augmentation. Ammunition to be throughput whenever possible. All other classes of supply, IV, VI, VII, VIII, and IX will be very much reduced and limited to combat essential items and levels.

- Risk. Accept more risk in order to minimized the deployability profile of the division.

- Materiel management. Decentralized and dependent on automation.

- Increased cost. The personnel and equipment savings have a concurrent effect of increasing cost. Reliance on exchange rather than fix, and floats rather than repair parts is costly. Prepackaged loads in all classes of supply will result in a higher percentage of waste.

- Automation. Maxium use of microcomputers is considered necessary to overcome the nonavailability of personnel in the manpower-intensive materiel management functions.

With the exception of the personnel functions performed at the division headquarters element, combat service support capabilities are found in the DISCOM. It includes an HHC, a medical battalion, a supply and transport battalion, a maintenance battalion, and an aircraft maintenance company. Support is orientated forward with emphasis on fueling, fixing, and rearming as close to the battle as possible. However, the design and actual capabilities impose some definite limits. See figure 4 for LID DISCOM organization.

Another structural change results from doctrine. The light division has no DMMC. The LID concept calls for battalions, acting in the role of commodity managers to bypass division using TACCS, or a similar microcomputer, and input to a large mainframe computer at corps level.

Augmentation and Deployment

The greatest concern to the light division support capabilities is the issue of augmentation, referred to as corps plugs. These corps plugs would not be dedicated to light infantry divisions; however, it is difficult to imagine a scenario where they would not be required. The division would be dependent upon augmentation for troop and supply transportation, petroleum supply units, medical units, personnel services and civil affairs, ammunition handling, and graves registration. The

Division Support Command
Light Infantry Division

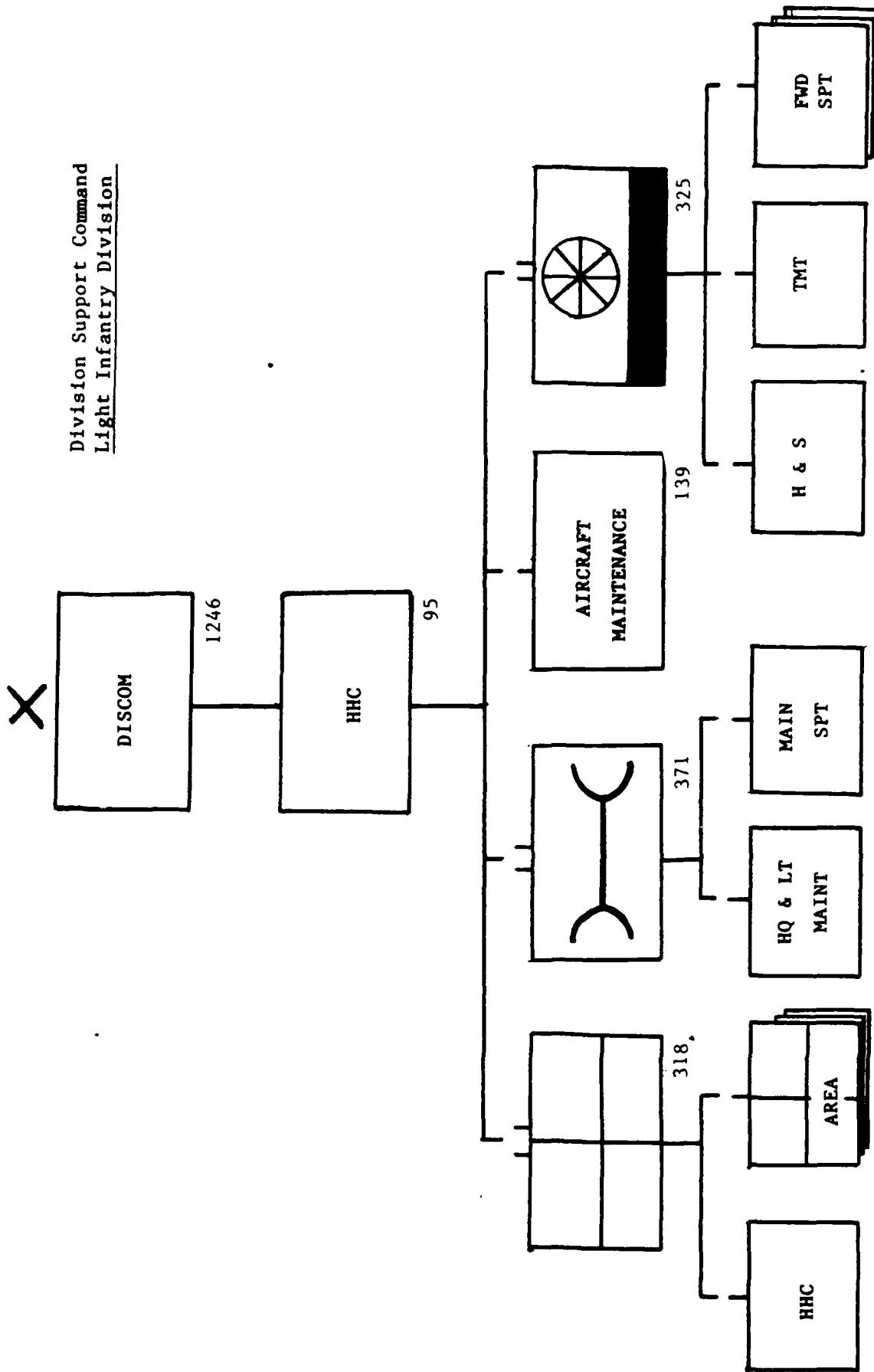

Figure 4

corps plugs for engineer, air defense, signal, and other combat support functions will, in turn, generate even further requirements for CSS. A summary of the light division's CSS capabilities is at figure 5.⁵ An extract of the augmentation matrix for the light division is at Appendix A.⁶

The original 400-500 sortie figure came out at 478 with the first design. After a few additions it is now officially listed as 500+. Planners take this to be approximately 520. It includes only the units organic to the light division, and those minimum essential forces in a low intensity conflict (LIC) environment. In almost every case corps units would have to deploy with the division. Under the most probable scenario, Southwest Asia, the corps augmentation would drive airframe requirements to over 700. Even using a LIC environment in Latin America, for a short duration, the force package would require at least 125 aircraft to deploy the corps augmentation.⁷

It also appears that the Logistics Center designers did not ensure that the LID included the required command and control systems necessary to integrate augmenting CSS assets. The doctrinal diagram for augmentation is at figure 6. Even if we assume the diagram is not all inclusive, and should contain the G1, G4, and DISCOM commander, the necessary structure does not exist in the organization. All of the staff elements and subordinate headquarters have been stripped to the bone. Without the organic capability or dedicated support practiced through

habitual training command and control may prove difficult to establish.

Simply operating in the day-to-day garrison environment has proven difficult. One division chief of staff wrote, "the LID organization didn't do us any favors. We make up for the shortfall in authorizations and manpower by late night and continuous weekend effort."

COMBAT SERVICE SUPPORT CAPABILITIES
of the
LIGHT INFANTRY DIVISION

CLASS I

- Battalion area field feeding
- Standard meal to be 1 MRE and 2 tray packs per day
- 229 cooks in the division
- Mobile kitchen trailers

WATER

- Three water points operated by DISCOM
- Supply point distribution
- Limited distribution to maneuver units using 1,500 gallon bags on back of stake and platform tractor trailer

CLASS III

- Push resupply, throughput from EAD
- Storage capacity provides 48 hour stand alone capability for MOGAS and DF-2 (DSA 30,000 gals, BSA 20,000 gals each)
- JP4 pushed from EAD to aviation brigade (Storage capacity is 30,000 gals or 3 days of supply)
- Storage is above ground in 10,000 gal bags

CLASS V

- 3 ammo transfer points - 1 per brigade
- Resupply to ATP by corps ammo units using corps transportation
- Each ATP can handle 250 ST per day
- Supply point distribution

TRANSPORTATION

- TMT company can lift 210 ST or 690 troops
- Support vehicles consist of 44 5-ton cargo trucks and 10 5-ton tractors with 22 1/2-ton trailers

MEDICAL SUPPORT

- Medical battalion with three DS companies
- Minimum holding capability - 20 beds per company
- Dental, X-ray, and lab services available
- 93 ambulances in division
- Air evacuation provided by EAD

PERSONNEL SERVICES

- Limited strength accounting, personnel management, replacement operations all contained within Division G1/AG

Augmentation Concept
Light Infantry Division

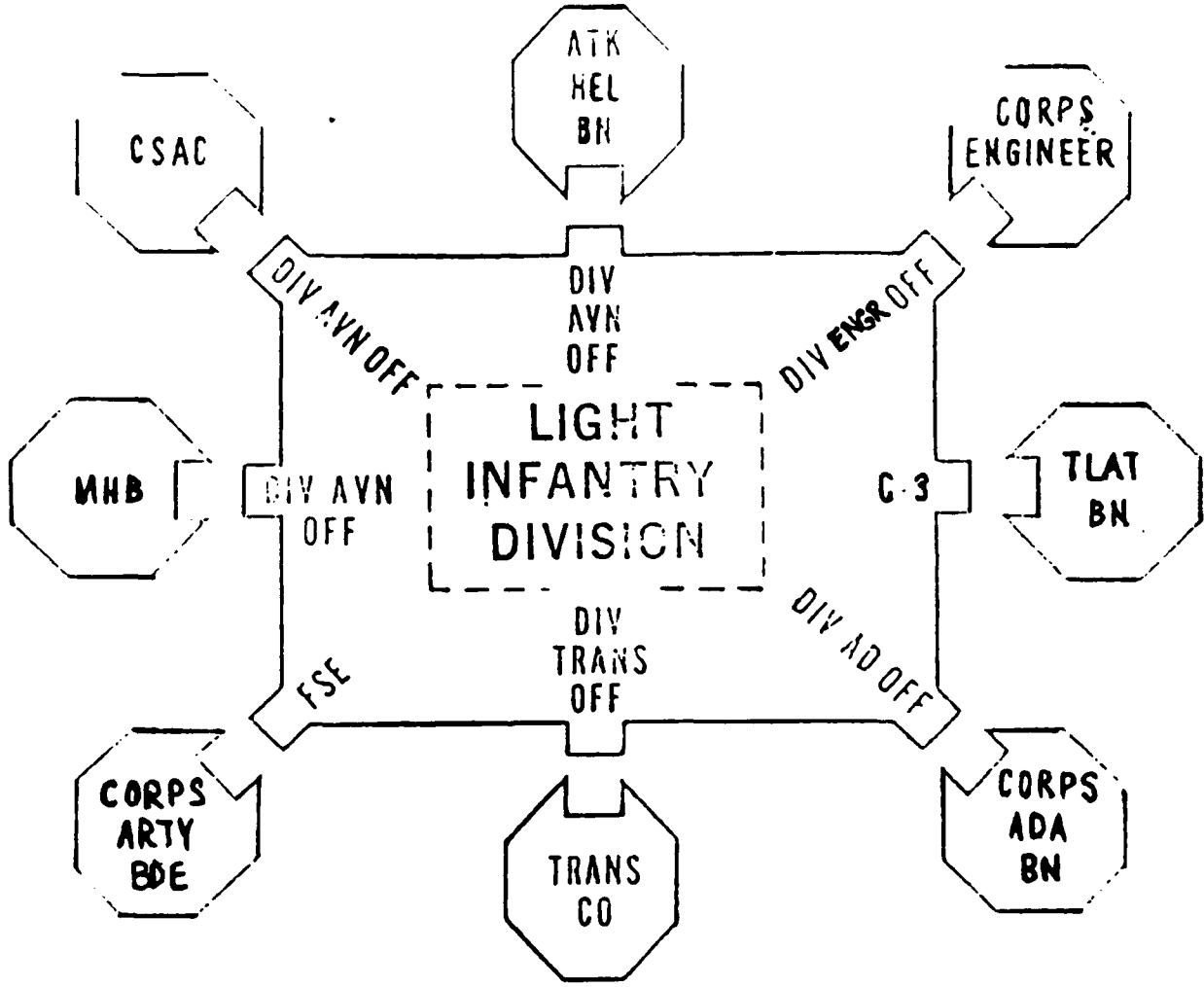

Figure 6

ENDNOTES

1. Field Circular 100-1, Volume II, p. 1.
2. Wickham, Light Division - White Paper, p. 3.
3. U.S. Department of the Army, Field Circular 71-101, Light Infantry Division Operations, (Fort Levenworth, 1984), p. 9-1.
4. Field Circular 100-1, Volume II, pp. 8-1 to 8-13.
5. Wickham, Report to SASC.
6. Field Circular 71-101, Appendix B.
7. Department of the Army, "Light Infantry Initiatives", A question and answer fact sheet prepared by DCSOPS for use before Congressional Committee, (April 1985).

CHAPTER VII

CONCLUSIONS

Having looked at what the AOE has given the Army, it is time to make some interim assessments. Clearly there was much of the Division 86 design and the supporting force that needed update. In this sense AOE can be viewed as a process of accepted evolution. It integrated the massive modernization program with new doctrine and attempted to capitalize on emerging "off the shelf" technologies. It attempted to reduce hollowness and provide more agile divisions. It beefed up the corps and gave it added ability to influence the Airland Battle. It gave us some streamlined, more readily deployable, light forces. Finally, it gave us some new CSS concepts and a greatly altered support structure. These last two items were perhaps more revolutionary than evolutionary. The concluding remarks will briefly assess the combat service support issues which have been discussed in this paper.

Heavy Divisions

The heavy divisions still have a significant CSS

capability, even though it was slashed by AOE. Where the entire division was reduced by 15 percent, the DISCOM lost more than 23 percent of its authorizations. Retention of the forward support battalions and the main support battalion left an efficient structure which can be task organized. However, the deletion of the functional battalions eliminated the backup necessary for any serious reconstitution effort.

Reductions were made in the maintenance areas based on industry advances in automated test sets and other sophisticated diagnostic maintenance equipment. However, much of this equipment has proven extremely difficult to operate and some performance has been disappointing.¹

Too much reliance has been placed on the assumption of host nation support. This notion may be acceptable in the NATO scenario; however, if we are to believe the threat assessment, this is the least likely theater for conflict. Almost all other contingencies depict an immature theater with a population, government, or support infrastructure unwilling or incapable of providing assistance.

Corps/Echelons Above Corps

At corps and EAC levels, the AOE experienced success in the ability to realign the CSS structure to provide better support.

The addition of rear area combat operations brigades, elimination of multiple missions, and ALO 1 staffing has certainly benefited the corps, COSCOM, and EAC units. Moderate increases to structure were realized in most functional areas.

It is too early to say all is well. The Logistics Unit Productivity Study may have overestimated the savings. Everything is based on increasing productivity and efficiency. If we can not realize savings under the LUPS program initiatives similar to what the signal community got from mobile subscriber equipment (minimum of two cable and wire companies and part of a radio battalion per corps)² the COMPO 4 CSS structure will climb right back up.

Much of what we need to make the CSS units productive and efficient, to the level AOE said was necessary, is not here. Until it is tested, fielded, and proven, the new philosophy which talks of increased support with decreased structure will be difficult to accept.

Light Divisions

When the light divisions were created, planners knew they had some significant problems with support. The Light Infantry Division Capability Analysis³ concluded that a corps has the ability to support a single light division. Augmentation will not solve the problem.

Some Army officials believe corps plugs are not an adequate substitute for having an organic capability. General Meyer, a former Army Chief of Staff, said " When you plug something in, you find it does not do well unless you offset the fact that the plugs are not permanent by some very, very strong training relationships." General Wickham also recognized this and his White Paper states "habitual training with corps augmentation units will enhance the combined arms concept. Colocating corps units with light infantry divisions will facilitate this training." However, many corps plugs will not be assigned to a particular division and the basic stationing problems will make "habitual training" extremely difficult.

The decision which took away organizations such as the AG company only to attach these very same soldiers, now assigned to a corps personnel service company, back to the division is suspect. The pride in belonging to a division is just as great for the CSS soldiers as it is for the front line soldier. It is hard to explain to someone working at the same job, in the same location, in support of the same organization, and doing so with less assets, why he is no longer part of the team. Reducing the deployment posture of the division has not significantly changed the total requirement. Does it really make any difference whose aircraft a soldier rides on?

Despite the scaled down requirements driven by the size and systems of the LID, a corresponding decrease in CSS personnel does not leave an adequate support level. The new logistical techniques have yet to prove their efficiency. Even with augmentation, some of the changes appear to fall short of providing required support. For example, one change involves the replacement of the "fix-forward" concept with an old "push-forward, pull-and-replace, or exchange" method. If the divisions do not fix broken or damaged equipment any more, there is doubt as to whether corps or theater level support units can keep up with a "push-forward" maintenance system. This philosophy has created a greater need for prepackaged stocks, most of which are not in the system or exist in insufficient quantities.

The elimination of the DMMC from the light division should be cause for genuine concern. This means more work for the DISCOM battalions which have already seen their robustness and redundancy stripped away. Although there are only a few success stories where automation and the installation of computers have actually resulted in decreased manpower requirements, this is exactly the rationale used to eliminate the DMMC. In many instances the performance of automation as a cure for personnel shortages has been disappointing.

General CSS Issues

Every summary of the Army of Excellence design talks about risk. The Army has long had a CSS shortfall. The current and projected CSS shortfall represents the decision to accept risk in support forces in order to strengthen deterrence in combat forces. This shortage is shared by heavy and light forces.

The designers of the Army of Excellence force have done an outstanding job. Working within the established constraints, building the structure for two additional divisions, scaling down the heavy divisions, and not greatly increasing the risk in other elements of the force was no small task. Unfortunately, what they could not see or predict was the mood of the Congress.

Implementation of the AOE initiatives requires resources. The Balanced Budget Amendment has already curtailed, reduced, or delayed many of the initiatives and productivity enhancement programs necessary for full AOE implementation. It is essential that as many of the programs as possible supporting the CSS mission will be kept alive. If the Army is able to weather the fiscal and manpower shortfalls with which it is faced in the current program years without a crisis requiring a major mobilization effort, the AOE structure has the potential to grow in a viable warfighting force with a competent sustaining force to back it up.

ENDNOTES

1. Edwin W. Besch, "Are Our Light Divisions Too Light?", Army, Volume 35, (February 1985), p. 45. Author was referencing statement made by Under Secretary of the Army.

2. Rush, p. 66.

3. Department of the Army, "Light Infantry Division Capability Analysis", Special Report, (Fort Levenworth, 1985), p. 14.

BIBLIOGRAPHY

1. Army War College Light Divisions - A selected Bibliography. Carlisle Barracks. December 1985.
2. Adams, John A. "Heavy Verses Light Forces: A Middle Ground." Military Review. Vol. LXVI, No. 10, October 1988, pp. 64-73.
3. Besch, Edwin W. "Are Our Light Divisions Too Light?" Army. Vol 35, No. 2, February 1985, pp. 42-48.
4. Damon, Sam and Krisler, Ben (Pseudonyms) "Army of Excellence? A Time To Take Stock." Armed Forces Journal. May 1985, pp. 86-94.
5. Downing, Wayne A. "Light Infantry Operations in Central Europe." Military Review. Vol. LXVI, No 9, September 1986, pp. 18-29.
6. Gordon, Michael R. "Light Doesn't Mean Easy." Military Logistian. Vol. I, No. 6, May 1985, pp. 28-33+.
7. Hartzog, William W. and Howard, John D. "Heavy / Light Operations." Military Review. Vol. LXVII, No. 4, April 1987, pp. 24-33.
8. Huddleston, Louis D. "Light Infantry Division: Azimuth Check." Military Review. Vol. LXV, No. 9, September 1985, pp. 14-21.
9. Landry, John R., et al., "CSS: Resourcing and Sustaining the Airland Battle." Military Review. Vol. LXVII, No. 1, January 1987, (A series of five related articles), pp. 23-61.
10. Ross, Jimmy D. "Jointness Receives Major Emphasis in Logistics Planning." Army. Vol. 37, No. 10, October 1987, pp. 148-159.
11. Rush, Robert S. "Comparing Light Divisions." Military Review. Vol. LXVIII, No. 1, January 1987, pp. 62-69.
12. Tice, Jim "Program to Cut Combat Service Support Manning by 12,500." Army Times. 23 November 1987, pp. 16+.
13. Wickham, John A. Jr. and Marsh John O. Jr. "The Posture of the United States Army for Fiscal Year 1987." Special Report by Department of the Army. Washington: 1986.

BIBLIOGRAPHY
continued

14. Wickham, John A. Jr. "U.S. Army Light Divisions." A Report to the Senate Armed Services Committee. Washington: Department of the Army, 1984.
15. Wickham, John A. Jr. "Total Army Readiness." Special Report. Washington: Department of the Army, 1984.
16. Wickham, John A. Jr. "Light Infantry Divisions." White Paper 1984. Washington: Department of the Army, 1984.
17. "Light Infantry Division Issue Papers." A collection of fact sheets and briefing charts from the files of the Light Infantry Division Task Force. Office of the Deputy Chief of Staff, Operations, Department of the Army, 1984-1987.
18. Personnel Structure and Composition System. Semi-annual reports produced by HQDA (DAMO) with current and projected authorizations. Department of the Army, 1983-1987.
19. U.S. Department of the Army, Field Manual 63-2: Combat Service Support Operations. Washington: 21 November 1983.
20. U.S. Department of the Army, Field Manual 63-3: Combat Services Support Operations - Corps. Washington: 24 August 1983.
21. U.S. Department of the Army, Field Manual 63-2-2: Combat Service Support Operations - Armored, Mechanized and Motorized Divisions. Washington: 29 October 1985.
22. U.S. Department of the Army, Field Manual 100-10: Combat Service Support. Washington: 1 March 1983.
23. U.S. Department of the Army, Field Circular 71-101: Light Infantry Division Operations. Fort Leavenworth, KS: 31 July 1984.
24. U.S. Department of the Army, Field Circular 100-1: The Army of Excellence. Fort Leavenworth, KS: 1 October 1984, with Vols. II, III, IV.
25. U.S. Department of the Army, TOE 770004J4: Light Infantry Division. Fort Monroe, VA: 1986.

Section XII. AUGMENTATION MATRIX--LIGHT INFANTRY DIVISION

B.84 A detailed discussion of augmentation units is continued in Appendix B of this field circular. Appendix B implies the doctrine for augmentation.

The augmentation concept for the light infantry division is situational dependent. Augmentation to the light infantry division reflects the reinforcement of the division with nonorganic assets to increase its capabilities. Augmentation can be provided to the division in the form of additional forces or additional support.

The conditions and parameters for command and support relationships are as follows:

- o Forces augmenting the division are normally attached or placed under the operational control (OPCON) of the division. However, augmenting forces may be assigned to the division when they are required for extended periods or when a permanent relationship is desired.

--When forces are attached to the division, the commander exercises the same degree of control over the attached unit as he does over organic units. He also assumes responsibility for providing administrative and logistic support.

--When forces are provided under the operational control of the division, the commander may employ the unit concerned and retain or delegate tactical control of the unit. The division is not responsible for the administrative and logistic support of OPCON units.

- o Additional support is provided to aid, complement, supplement, or sustain the division. The supporting unit remains under the command of its parent headquarters; however, the supporting unit responds to the division's requests for support. The command relationship of support is frequently established by the assignment of a tactical mission to the supporting unit. This includes direct support, general support, reinforcing, general support reinforcing, or the broader term support with an explanatory directive.

FC 71-101 specifically discusses command relationships associated with the following units/elements:

- o Command and control.
- o Close combat forces.
- o Aviation.
- o Air defense artillery.
- o Fire support.
- o Communications.
- o Intelligence and electronic warfare.
- o Engineer.
- o Nuclear, biological, and chemical (NBC).
- o Combat service support (CSS).

B.85 The matrix which follows is provided for quick and easy reference. It is important to remember that the command relationship and/or support relationship of a unit to the light infantry division is situational dependent. By no means is this augmentation matrix intended to serve as an absolute representation or rule for determining command or support relationships.

AUGMENTATION MATRIX		SUPPORT RELATIONSHIPS	
AUGMENTATION UNIT/ELEMENT	PARENT UNIT	DIVISION INTERFACE ELEMENT	COMMAND RELATIONSHIPS
		COMMAND AND CONTROL	
Replacement det	PSC (DS) R&A bn	G1/AG section	DS
Mbl ply team	PSC (DS) R&A bn	G1/AG section	DS
Personnel svc det	PSC (DS) R&A bn	G1/AG section	DS
Morale svc det	PSC (DS) R&A bn	G1/AG section	DS
Postal team	PSC (DS) R&A bn	G1/AG section	DS
MP plt; co; bn	MP bde	Provost marshal, staff	attached
Civil Affairs team; co	CA bn	G5; staff	DS
PSYOP tm; co	PSYOP bn	G3; staff (coord w/G5)	DS
		CLOSE COMBAT FORCES	
Maneuver bn; bde	Other mvr div	G3 and staff	OPCON or attached
Lt armd cav regt	Other mvr div	G3 and staff	OPCON or attached
Sep bde	Corps	G3 and staff	OPCON or attached
Anti-armor bn (sep)	Corps	G3 and staff	OPCON or attached
Armd cav trp; sqdn	Armd cav regt	G2 and staff (coord w/G3)	OPCON or attached
Air cav trp; sqdn	Lt armd cav regt	G2 and staff (coord w/G3)	OPCON or attached
Atk hel bn	Avn bde	G3 and staff	OPCON or attached
Long-range surveillance (LRS) Corps LRS co	Corps LRS co	G2 and staff (coord w/G3)	OPCON or attached
Cbt avn co; bn	Avn bde	G3 and staff	DS; GS
		FIRE SUPPORT	
FA bde	Corps	FSCOORD	OPCON or attached
Cannon bn (155-mm and 8-in)	Arty bde	FSCOORD	DS; GS; GSR; rel nf
M.LRS btry; bn	Arty bde	FSCOORD	DS; GS; GSR; rel nf
Tgt acq btry; bn	Arty bde	FSCOORD	DS; GS; GSR; rel nf

<u>AUGMENTATION UNIT/ELEMENT</u>	<u>PARENT UNIT</u>	<u>DIVISION INTERFACE ELEMENT</u>	<u>COMMAND RELATIONSHIPS</u>	<u>SUPPORT RELATIONSHIPS</u>
		<u>AIR DEFENSE</u>		
ADA bn York/Stinger	Corps ADA bde	Div ADA off (coord w/G3)		DS; reinf
Chap bn	Corps ADA bde	Div ADA off (coord w/G3)		DS; reinf
		<u>COMMUNICATIONS</u>		
Area sig co; bn	Sig bde	C-E off and staff		DS, GS
		<u>IEW</u>		
MI op bn	MI (CEMI) gp	G2 w/IEW unit cdr		DS; GS
MI aerial explt bn	MI (CEMI) gp	G2 w/IEW unit cdr		DS; GS
MI tac explt bn	MI (CEMI) gp	G2 w/IEW unit cdr		DS; GS
IPW team	TAC xpilt bn	G2 w/IEW unit cdr	attached	
CI team	TAC xpilt bn	DTOC spt elm and G3	attached	
IEW sec; op co	MI op bn, MI gp	DTOC spt elm and G3	attached	
Terminal comm co	MI op bn, MI gp	G2 w/IEW unit cdr, DTOC spt elm and C-E off	attached	
EW team; EW co	Tac xpilt bn	G2 w/IEW unit cdr, DTOC spt elm and G3	attached	
		<u>ENGINEER</u>		
Cbt engr co; bn	Engr bde	Engr bn and his staff		DS; GS
ADM plt; co; bn	Engr bde	G3 and engr bn cdr w/his staff		DS; GS
		<u>NBC</u>		
Cml co/smoke	NBC bde	Cml and NBC	attached	
Cml bde	NBC bde	Cml and NBC	attached	

<u>AUGMENTATION UNIT/ELEMENT</u>	<u>PARENT UNIT</u>	<u>DIVISION INTERFACE ELEMENT</u>	<u>COMBAT SERVICE SUPPORT</u>	<u>COMMAND RELATIONSHIPS</u>	<u>SUPPORT RELATIONSHIPS</u>
AVIM det	AVIM bn, COSCOM	DISCOM and div avn off		DS	
AMC	Avn maint bn, COSCOM	Div avn off and DTO		DS	
Med hel co; bn	Avn bde	Div avn off and DTO		DS; GS	
Slp tas; co	S&S bn, COSCOM	G4 plans, DISCOM implements		DS	
Mobile maint tas	Maint bn, COSCOM	G4 plans, DISCOM implements		DS	
Trans co	Trans bn, COSCOM	G4 and staff w/avn off and DTO		DS; GS	
Fld svc tas, co	S&S bn, COSCOM	G4 plans; DISCOM implements		DS	
Med bn	Med bde, EAC	G4 (coord w/surg)		DS; GS	
Air amb det, co	Med bde, EAC	G4 (coord w/surg)		DS; GS	
Amb plt, co	Med bde, COSCOM	G4 (coord w/surg)		DS; GS	
CSH	Med bde, EAC	G4 (coord w/surg)		GS	
Evac hosp	Med bde, EAC	G4 (coord w/surg)		GS	
MASH	Med bde, EAC	G4 (coord w/surg)		DS; GS	
Med det, tm LB	Med bde, COSCOM	G4 (coord w/surg)		DS	
Med co, clearing	Med bde, COSCOM	G4 (coord w/surg)		DS; GS	
Fin co	Fin bn, COSCOM	G1/AG		DS	
EOD det; co	COSCOM	G4, DISCOM (coord w/G2 and G3)		DS; GS	
Ammo co	Ammo bn, COSCOM	G4, DISCOM		DS; GS	