

*ite technical note techn*

DTIC FILE COPY

2

AD-A196 032

# Loran C Coverage in Alaska After Dual Rating Port Clearance

Robert H. Erikson

June 1988

DOT/FAA/CT-TN88/22

This document is available to the U.S. public through the National Technical Information Service, Springfield, Virginia 22161.



U.S. Department of Transportation  
Federal Aviation Administration

Technical Center  
Atlantic City International Airport, N.J. 08405

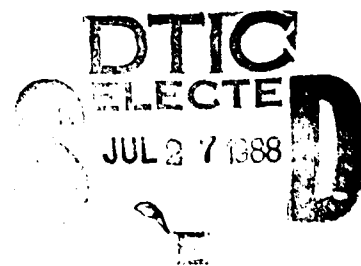

1. Report No. DOT/FAA/CT-TN88/22	2. Government Accession No.	3. Recipient's Catalog No.	
4. Title and Subtitle LORAN C COVERAGE IN ALASKA AFTER DUAL RATING PORT CLARENCE		5. Report Date June 1988	6. Performing Organization Code ACT-140
		8. Performing Organization Report No. DOT/FAA/CT-TN88/22	
7. Author(s) Robert H. Erikson		10. Work Unit No. (TRAIS)	11. Contract or Grant No. T0702N
9. Performing Organization Name and Address Federal Aviation Administration Technical Center Atlantic City International Airport, N.J. 08405		13. Type of Report and Period Covered Technical Note June 1987	
		14. Sponsoring Agency Code	
15. Supplementary Notes			
<p>16. Abstract</p> <p>This report describes flight tests conducted by the Federal Aviation Administration (FAA) Technical Center to measure Loran C coverage in Alaska. The flight tests were conducted within the state of Alaska after Loran C station Port Clarence was added to the Gulf of Alaska chain by dual rating the station. Flight tests were conducted in June 1987.</p> <p><i>Approved for Release</i></p>			
17. Key Words Loran C, Alaska Port Clarence, Alaska		18. Distribution Statement This document is available to the U.S. Public through the National Technical Information Service, Springfield, Va. 22161	
19. Security Classification (of this report) Unclassified	20. Security Classification (of this page) Unclassified	21. No. of Pages 39	22. Price

TABLE OF CONTENTS

	Page
EXECUTIVE SUMMARY	ix
INTRODUCTION	1
Objective	1
Background	1
Related Documentation	1
EQUIPMENT AND DATA COLLECTION	2
Data Acquisition System	2
Position Reference System	2
Spectrum Analyzer/Oscilloscope	2
TEST PROCEDURES	4
DATA REDUCTION	6
RESULTS	6
ANALYSIS OF RESULTS	7
Atmospherice Noise	7
Signal Strength Coverage	7
ECD	9
Position Error	9
Summary of Coverage	9
CONCLUSIONS	10
RECOMMENDATIONS	10
APPENDIX	

Accession For	
NTIS GRA&I	<input checked="" type="checkbox"/>
DTIC TAB	<input type="checkbox"/>
Unannounced	<input type="checkbox"/>
Justification	
By _____	
Distribution/	
Availability Codes	
Dist	Avail and/or Special
A-1	



## LIST OF ILLUSTRATIONS

Figure		Page
1	Data Collection System	10
2	Flight Route	11
3	Field Strength for Tok	12
4	Field Strength for Narrow Cape	13
5	Field Strength for Port Clarence	14
6	Atmospheric Noise	15
7	SNR(FS) for Tok	16
8	SNR(FS) for Narrow Cape	17
9	SNR(FS) for Port Clarence	18
10	SNR(PH) for Tok	19
11	SNR(PH) for Narrow Cape	20
12	SNR(PH) for Port Clarence	21
13	ECD for Tok	22
14	ECD for Narrow Cape	23
15	ECD for Port Clarence	24
16	TD Bias for MX	25
17	TD Bias for MT	26
18	Position Shift	27
19	Summary of Loran C Coverage From Flight Tests	28

LIST OF TABLES

Table		Page
1	Recorded Data	3
2	Flight Test Routes	5
3	Waypoint Positions	6

## EXECUTIVE SUMMARY

An analysis by the Federal Aviation Administration predicted Loran C coverage could be expanded throughout the interior of Alaska by modification of an existing Loran C transmitter. The modification would include adding Loran C station Port Clarence as a secondary on the Gulf of Alaska chain (7960) by dual rating the station.

During the summer of 1985 and winter of 1986, flight tests were conducted by the Federal Aviation Administration Technical Center to measure existing Loran C signals. These measurements were necessary to determine if the signal strengths from Loran C stations Tok, Narrow Cape, and Port Clarence were adequate for proper receiver operation. Estimates of position error could not be determined because the stations were operating on different chains. The purpose of adding Loran C station Port Clarence as a secondary on the Gulf of Alaska chain was to provide for the formation of a triad where all three stations would operate on the same chain. This was necessary for a single chain Loran C receiver to properly determine a position fix. Based on these flights it was decided to add Loran C station Port Clarence as a secondary on the Gulf of Alaska chain by dual rating the station. Loran C station Port Clarence was dual rated in the spring of 1987.

This report describes a flight test probe conducted in the summer of 1987 into the interior of Alaska to determine the extent of usable signals after dual rating Loran C station Port Clarence. The Loran C stations of interest were Port Clarence, Narrow Cape, and Tok, all operating on the Gulf of Alaska chain (7980). Most of the flights were conducted south of the Brooks Range, but limited flights were also conducted north of the Brooks Range. Flight measurements indicated a largely increased operational area located in the middle to southern interior of Alaska.

## INTRODUCTION

### OBJECTIVE.

The objective of this project was to investigate the extent of usable Loran C signals throughout the interior of Alaska, after adding Loran C station (LORSTA) Port Clarence as a secondary to the Gulf of Alaska chain.

### BACKGROUND.

A Federal Aviation Administration (FAA) analysis indicated that Loran C coverage would be increased by approximately 93,000 square miles if LORSTA Port Clarence was added as a secondary to the Gulf of Alaska Chain. This additional coverage would provide service to 98 percent of the population of Alaska and 93 percent of the state's airports.

During the summer of 1985 and winter of 1986 the FAA Technical Center conducted flight tests to evaluate Loran C coverage in Alaska. The tests were designed to evaluate the feasibility of adding LORSTA Port Clarence as a secondary on the Gulf of Alaska chain. Signal strength and noise levels were measured while the stations were operating on different chains; therefore, positional errors could not be measured. Based on these results it was decided to dual rate LORSTA Port Clarence. The results of this effort were reported in "Alaska Loran C Probe Test Results" (Related Documentation number 1).

The FAA designated funds in the fiscal year 1987 budget to allow the United States Coast Guard (USCG) to dual rate LORSTA Port Clarence, Alaska. The station was to function as a new secondary on the Gulf of Alaska Loran C chain. This would be in addition to its current function as the Yankee (Y) secondary on the North Pacific Loran C chain. LORSTA Port Clarence was added as a secondary on the Gulf of Alaska chain by dual rating for testing purposes in the spring of 1987. The system area monitor necessary for closed loop control of the transmitter was not installed at this time. Control of the transmitter was, therefore, by open loop methods.

During June 1987, the FAA Technical Center conducted flight tests to obtain Loran C data on the Gulf of Alaska chain with LORSTA Port Clarence operating as a secondary on this chain. This report addresses the signal quality of the Loran C signals measured from Loran C stations Port Clarence, Narrow Cape, and Tok based on the flight data.

### RELATED DOCUMENTATION.

1. Erikson, Robert; Evans, Jean; Dickinson, Mark; Wisser, Thomas; and Wortham, Martin, Alaska Loran C Probe Test Results, FAA Technical Center, Technical Note DOT/FAA/CT-TN87/23, September 1987.
2. Till, Robert D., Helicopter Global Positioning System Navigation With the Magnavox Z-Set, FAA Technical Center, Technical Note DOT/FAA/CT-TN83/03, August 1983.
3. Feldman, Donald A., An Atmospheric Noise Model with Application to Low Frequency Navigation Systems, United States Coast Guard, DOT-CG-13446-A, June 1972.

4. Approval of Area Navigation Systems for Use in the U.S. National Airspace System, FAA Advisory Circular 90-45A, February 21, 1975.

5. Slagle, D. and Wenzle, R., Loran C Signal Stability Study: St. Lawrence Seaway, U.S. Coast Guard, CG-D-39-82, July 1982.

## EQUIPMENT AND DATA COLLECTION

### DATA ACQUISITION SYSTEM.

The FAA Technical Center's Convair CV-580 aircraft was equipped with two Advanced Navigation Incorporated ANI-7000 Loran C receivers. These units were production models. One unit had the software modified to include LORSTA Port Clarence as a secondary on the Gulf of Alaska chain. Software versions for the modified unit were 5.60 NAV and 4.26 REC. The unmodified unit had software versions 5.09 NAV and 4.15 REC.

A Norden militarized PDP 11/34M computer was used to collect the data. The data were recorded on a Miltope 9-track tape recorder. A Technical Center designed aircraft systems coupler was used to interface the Loran C receivers, aircraft state sensors, and position reference system to the Norden computer. Figure 1 is a block diagram of the system. Data recorded on the 9-track tape are presented in table 1.

The ANI-7000 Loran C receiver was used in its automatic or wide open mode which automatically selects and deselects the various chains and stations. This method allowed the receiver to track the stations of interest: Tok, Narrow Cape, and Port Clarence. The data collection system sampled and recorded the Loran C data and aircraft parameters every 10 seconds. The exception to this was the barometric altitude from the air data computer which was recorded every second. Global Positioning System (GPS) data were recorded as available (nominally every 1.2 seconds).

In-flight printouts were generated every 30 seconds. Time, Inertial Navigation System (INS) position, and the differences in position between the INS and the respective Loran C and GPS receivers were printed for in-flight observation of the data.

### POSITION REFERENCE SYSTEM.

A GPS receiver, the Magnavox Z-set (Related Documentation Number 2) provided the primary aircraft position reference. The GPS accuracy is predicted to be better than 100 meters 2 distance root mean squared (drms).

### SPECTRUM ANALYZER/OSCILLOSCOPE.

The Loran C spectrum was observed using a Tektronix 7L5 spectrum analyzer scope plug-in. Monitoring of Loran C pulses was accomplished using a Tektronix 7A26 dual trace amplifier and 7B53 dual time base scope plug-ins. The desired scope plug-ins were installed as needed in a Tektronix R7603 mainframe oscilloscope which was permanently installed in the Technical Center CV-580. The signals were received using a Bayshore UPS-95 antenna and coupler.

TABLE 1. RECORDED DATA

Aircraft Sensors and Time

Time: Hours, minutes, seconds  
LTN-51 INS: Present position, heading, track angle,  
ground speed  
ADC-80: True airspeed, altitude  
CDI: Analog CDI  
GPS: Present position, velocities, and time

ANI-7000 Loran C Receiver Data

Present Position Lat/Long  
Stations Used for Navigation Solution  
Station Status (8 stations)  
Station SNR (8 stations)  
Station Field Strength (8 stations)  
Atmospheric Noise  
ECD (8 stations)  
Time Differences (8 Time of Arrivals)  
Secondary Phase Delay (all stations in track)  
Notch Filter Setting  
Front Panel Switch Setting  
Annunciator Lamps  
Receiver Status  
En Route/Approach  
To Waypoint Lat/Long  
From Waypoint Lat/Long  
Crosstrack Error  
Ground Speed  
Distance to Go  
Grid Reference  
Bearing to Waypoint  
Desired Track  
Estimated Time En Route

Note:

ADC = Air data computer  
CDI = Course deviation indicator  
ECD = Envelope-to-cycle difference  
GPS = Global positioning system  
INS = Inertial Navigation System  
LTN = Litton  
SNR = Signal-to-noise ratio

## TEST PROCEDURES

Based on earlier flight measurements and theory, the USCG predicted Loran C coverage for the newly formed triad. Predicted coverage was based on a 1/4 nautical mile (nmi) fix accuracy (95 percent 2 drms) with a 1:3 signal to noise ratio (SNR). Fix accuracy accounts only for the random position error and does not include differences between the propagation model and the real world. SNR expressed as a 1:3 ratio is equivalent to -10 decibel (dB). Figure 2 shows a map of Alaska provided by the USCG with the expected Loran C coverage and the location of the Loran C transmitters plotted. The limit of coverage is shown in figure 2 by a solid line. Loran C transmitters are annotated on the figure with a solid box. The baselines for the triad are also plotted. The Loran C stations of interest were Tok (M), Narrow Cape (X), and Port Clarence (T), all located in Alaska and part of the Gulf of Alaska chain. The group repetition interval for the Gulf of Alaska chain is 7960.

The flight route was selected to be at or near the limit of predicted coverage. Flights were conducted mostly south of the Brooks Range where coverage was expected. Limited flights were conducted north of the Brooks Range to obtain signal amplitude data from LORSTA Tok and LORSTA Port Clarence for future information. The actual flightpath was chosen to follow the existing very high omni-directional radio range (VOR) routes when possible. It was possible to use the VOR routes for all segments except for the flight from Bettles to Kotzebue. This segment was flown using the INS. The flight test routes are listed in table 2 and the waypoint positions used for the routes are listed in table 3. Flight routes and waypoints are shown in figure 2.

Loran C signal parameter data were to be collected on all flight routes. Poor Loran C receiver performance due to aircraft related noise or locally generated atmospheric noise was considered as atypical and the routes were reflown. Loran C signal parameter and aircraft position reference data were monitored during flight for proper operation. Signal reception on Loran C stations Tok, Narrow Cape, and Port Clarence on the Gulf of Alaska chain was considered critical. On several occasions the receiver lost track of the Loran C stations due to precipitation static. Since precipitation static is an aircraft dependent condition, segments lost due to precipitation static were reflown.

Desired flight altitudes were 1000 feet above ground level. Due to the limited number of airports which could support the aircraft and logistics, a higher altitude was necessary for fuel efficiency. The higher altitudes allowed longer flight segments. The target altitude was 17,000 feet mean sea level. All flights were flown at approximately this altitude except when minimum en route altitudes required higher values. The effect of this higher altitude on the measured data is expected to be lower propagation errors and higher field strengths than would exist near the earth's surface. The magnitude of these changes have not been well documented. One previous test conducted to study this effect (Related Documentation number 1) was unable to show proof of the effect.

TABLE 2. FLIGHT TEST ROUTES

<u>Date</u>	<u>Route</u>
6/8/87	Anchorage Fairbanks Fort Yukon Bettles Kotzebue Galena McGrath Anchorage
6/9/87	Anchorage Kenai King Salmon Bethel Nome Kotzebue Galena McGrath Anchorage
6/10/87	Fairbanks Fort Yukon Deadhorse Point Barrow Bettles Fort Yukon Fairbanks
6/11/87	Fairbanks Bettles Deadhorse Barter Island Fort Yukon Fairbanks Anchorage Kenai Terminated flight 170 nmi to King Salmon
6/12/87	Anchorage Kenai Terminated flight 100 nmi to King Salmon

TABLE 3. WAYPOINT POSITIONS

	<u>Name</u>	<u>Latitude (N)</u>	<u>Longitude (W)</u>
AKN	King Salmon	58° 43.5'	156° 45.0'
ANC	Anchorage	61° 09.1'	150° 12.3'
BET	Bethel	60° 47.1'	161° 49.3'
BGR	Big Lake	61° 34.2'	149° 57.9'
BRW	Point Barrow	71° 16.4'	156° 47.1'
BTI	Barter Island	70° 07.9'	143° 38.5'
BTT	Bettles	66° 54.3'	151° 32.0'
ENA	Kenai	60° 36.9'	151° 11.6'
FAI	Fairbanks	64° 48.0'	148° 00.6'
FYU	Fort Yukon	66° 34.5'	145° 16.4'
GAL	Galena	64° 44.3'	156° 46.5'
MCQ	McGrath	62° 57.1'	155° 36.5'
OME	Nome	64° 29.2'	165° 15.1'
OTZ	Kotzebue	66° 53.2'	162° 32.2'
SCC	Deadhorse	70° 12.0'	148° 24.8'

## DATA REDUCTION

A data base was constructed which included the following parameters: aircraft position (GPS), atmospheric noise, field strength, SNR derived from phase, SNR derived from field strength, envelope-to-cycle difference (ECD), and time differences (TD's). The field strength, SNR, and ECD values were obtained for the Tok, Port Clarence, and Narrow Cape Loran C stations on the Gulf of Alaska chain. TD's were for the Tok - Narrow Cape and Tok - Port Clarence lines of position.

Construction of the data base involved the merging of the aircraft position reference and Loran C data with respect to time. Merging of the data was done to within 0.1 second. The GPS data were used to produce an aircraft position reference file for merging. The aircraft position reference file has a position reference every 0.1 second. The high resolution position reference file is obtained by linearly interpolating the GPS position between the nominal 1.2-second GPS updates. Loran C receiver station tracking status was also included in the data. Loran C signal parameter data were only used for analysis if the receiver indicated it was properly tracking the Loran C station. The data base was generated with data points every 10 seconds.

## RESULTS

Plots of signal to noise ratio (phase) (SNR(PH)), signal to noise ratio (field strength) (SNR(FS)), ECD, field strength, atmospheric noise, and TD bias were plotted to present the results of the flight tests. Data were only plotted from the ANI-7000 receiver with the software modified to use LORSTA Port Clarence on the Gulf of Alaska chain. For analysis purposes, the average of 60 consecutive points were plotted. The averaged data point was plotted at the latitude and

longitude for the middle data point. With a ground speed of approximately 250 knots, this means a point was plotted every 40 nmi. Effects of antenna height have not been factored into the field strength and atmospheric noise data. To compensate for the antenna, 2 dB (Related Documentation Number 1) must be added to the data presented for field strength and atmospheric noise to obtain the actual values. SNR and ECD are not affected by this correction factor.

Figures 3 to 5 show the field strength of LORSTA Tok (M), LORSTA Narrow Cape (X), and LORSTA Port Clarence (T), respectively. Field strength is presented in dB per microvolt per meter.

Figure 6 is a plot of the atmospheric noise. Atmospheric noise is presented in dB per microvolt per meter through a 30 kilohertz bandpass filter.

Figures 7 to 9 are plots of SNR(FS) for LORSTA Tok (M), LORSTA Narrow Cape (X), and LORSTA Port Clarence (T), respectively. SNR(FS) is the SNR computed by subtracting the atmospheric noise from the field strength. SNR(FS) is presented in dB.

Figures 10 to 12 are plots of SNR(PH) for LORSTA Tok (M), LORSTA Narrow Cape (X), and LORSTA Port Clarence (T), respectively. SNR(PH) is the SNR computed from phase tracking information of the Loran C pulse. SNR(PH) is presented in dB.

Figures 13 to 15 are plots of ECD for LORSTA Tok (M), LORSTA Narrow Cape (X), and LORSTA Port Clarence (T). To obtain ECD in microvolts, the values presented on the plot must be divided by 10.

Figure 16 and 17 show the TD bias for the MX and MT baselines, respectively. TD bias is the difference between the measured TD's at a point and the predicted TD's at the same point. The predicted TD's are based on the Defense Mapping Agency's Loran C seawater propagation model. See the appendix for the equations used for the propagation model. A positive TD bias means the measured TD was greater than the predicted value.

## ANALYSIS OF RESULTS

### ATMOSPHERIC NOISE.

Review of atmospheric noise from figure 6 shows the noise level varies from 35 dB per microvolt per meter near Barter Island to 59 dB per microvolt per meter near Port Clarence. The noise levels generally changed slowly over a large area. Peaks in the noise occurred near Point Barrow, McGrath, and Port Clarence. Flight notes indicate the aircraft was charged by precipitation static in these areas so that the measured noise will be higher than actually existed in these areas. Due to the short duration of the noise bursts these flight segments were not repeated.

### SIGNAL STRENGTH COVERAGE.

Evaluation of signal coverage was based on the -10 dB SNR limit used by the USCG. The receiver used for this series of tests estimates an SNR value using field strength and atmospheric noise or jitter of the standard tracking point in the

Loran C pulse. The SNR value obtained using each method will be different given the same signal environment. SNR determined from the jitter of the standard tracking point will be higher than with the field strength and atmospheric noise method. SNR(PH) may be higher than SNR(FS) by 6 to 18 dB due to limiting and clipping performed in the cycle tracking loop and the type of noise (Related Documentation number 3). For this analysis an SNR(PH) of 0 dB will be considered equal to an SNR(FS) limit of -10 dB.

The Loran C receiver lost track of LORSTA Tok when flying over Norton Sound and did not reacquire LORSTA Tok until reaching Kotzebue. Field strength for this station as shown in figure 3 indicates the field strength was below 40 dB per microvolt per meter after passing King Salmon until the receiver lost track at Norton Sound. Review of SNR(FS) (figure 7) for LORSTA Tok shows the SNR to be below the USCG predicted value of -10 dB between King Salmon and Kotzebue. Using an SNR limit of 0 dB for SNR(PH) and reviewing figure 10 shows that the SNR became marginal in about the same area as SNR(FS). These results are very similar to the USCG predicted limits for the western part of the coverage area. Data also indicates that adequate signals exist throughout the other areas flown including the North Slope except where previously mentioned.

Signal propagation from LORSTA Tok in the direction of McGrath indicates that the signal attenuation rate may be greater than in other directions. This is justified by reviewing the field strength plots for LORSTA Tok (figure 3). On the flights between Anchorage and Fairbanks, the field strength dips about midway between the two locations. The field strength dips again around McGrath. On the flight from King Salmon to Nome the signal shows a much smaller dip. The signal path from LORSTA Tok towards McGrath crosses Mt. McKinley, which contains areas of glacial ice. Glacial ice attenuates the signal at a greater rate than most other types of soil or water.

The field strength from LORSTA Narrow Cape (figure 4) is generally above 40 dB per microvolt per meter except when north of Fort Yukon. The data does not show the expected increase in signal as it propagates up Cooks Inlet towards Bettles and Fort Yukon. The reason may be that the benefits of better signal propagation over the water path of Cooks Inlet are reduced by the poor signal propagation over the glacial ice of Mt. McKinley. A more detailed analysis of the data would be needed to validate this assumption. Since the area in question is small no detailed analysis in this area was conducted for this report.

Review of plots of SNR(FS) (figure 8) and SNR(PH) (figure 11) for LORSTA Narrow Cape using the same limits as for LORSTA Tok, shows that the SNR became marginal when west of a point midway between Kotzebue and Bettles. SNR north of Nome in the western part of the state was marginal. Both of these areas were predicted to be weak by the USCG. SNR north of Fort Yukon in the north eastern part of the state was also marginal. SNR values in the north eastern part of the state were expected to be better according to the USCG predictions.

The field strength for LORSTA Port Clarence (figure 5) was generally greater than 40 dB per microvolt per meter for all areas flown except between Fort Yukon and Barter Island. SNR(FS) (figure 9) was generally greater than -10 dB and SNR(PH) (figure 12) was generally greater than 0 dB for LORSTA Port Clarence except around McGrath and between Fort Yukon and Barter Island. The low SNR's at these two locations were due to an increased atmospheric noise level due to precipitation static. The location and increased power of LORSTA Port Clarence made signal coverage good for all areas flown.

### ECD.

ECD measurements by the test receiver have been suspect. Limited laboratory testing indicates that the receiver measures the ECD with a constant bias of about +0.5 microseconds. Currently, the Minimum Operational Performance Specification (MOPS) requires Loran C receivers to operate with ECD values between -2.4 and +3.0 microseconds. The proposed Technical Standard Order (TSO) covering Loran C receivers increases the upper limit to +3.5 microseconds.

ECD values for LORSTA Tok (figure 13) became negative between Bethel and Nome, and again when north of Fort Yukon. No values greater than +2.0 microseconds or less than -2.8 microseconds were measured for LORSTA Tok, except on the flight from Bethel to Nome just before the receiver lost track of the station. ECD values for LORSTA Narrow Cape (figure 14) ranged from -3.2 to +1.6 microseconds, except when near Port Clarence where the ECD went as low as -4.6 microseconds. ECD values for LORSTA Port Clarence (figure 15) ranged from -2.4 to +2.1 microseconds.

### POSITION ERROR.

TD bias for the MX line of position (figure 16) shows the TD bias to vary from 1.6 microseconds up to 3.6 microseconds. The TD bias changed slowly with position.

Review of figure 17 shows the TD bias for the MT line of position varied from 5.2 microseconds to +1.4 microseconds except for a point near McGrath. At McGrath the TD bias rapidly decreased to -9.8 microseconds. For all other areas the TD bias slowly changed with position.

Figure 18 shows the result of converting the TD bias for the MX and MT lines of position to a shift in position based on the Loran C geometry. The position shift presented in figure 18 is the radial shift in position. Equations for converting TD bias to a position shift can be found in the appendix. To obtain the position shift in feet from the plot multiply the values presented by 100. The radial position shift varied from 300 to 7400 feet. No position shifts could be determined north of Fort Yukon or in the area around Nome because TD bias values were not available from both lines of position.

The intent of this project was to investigate the propagation of the Loran C signals. In order to make the information useful to other people, the method used to determine position errors had to be traceable and published. The previously mentioned method was used in place of the Loran C receiver's position solution because it was traceable to known equations which could be duplicated by others. The Loran C receivers propagation model is proprietary and could not be published.

### SUMMARY OF COVERAGE.

Figure 19 shows a comparison of the USCG predicted Loran C coverage with the coverage obtained from flight tests. Coverage from flight data was defined to be those areas where Loran C stations Tok, Narrow Cape, and Port Clarence could be received with an SNR(FS) greater than -10 dB, an SNR(PH) greater than 0 dB, and ECD values between -3.0 and +3.5 microseconds. USCG predicted coverage is shown in the figure with a solid line and flight data coverage is shown as a cross hatch.

## CONCLUSIONS

Flight test data verified the U.S. Coast Guard (USCG) predicted Loran C coverage for the Gulf of Alaska chain using Loran C stations Tok, Narrow Cape, and Port Clarence with one exception. The one exception was the coverage north of Fort Yukon. Flight data showed sufficient signal levels for reliable navigation from Loran C station Narrow Cape did not exist when north of Fort Yukon contrary to the USCG prediction.

## RECOMMENDATIONS

Continue with the necessary work required to declare Loran C station Port Clarence operational on the Gulf of Alaska chain.

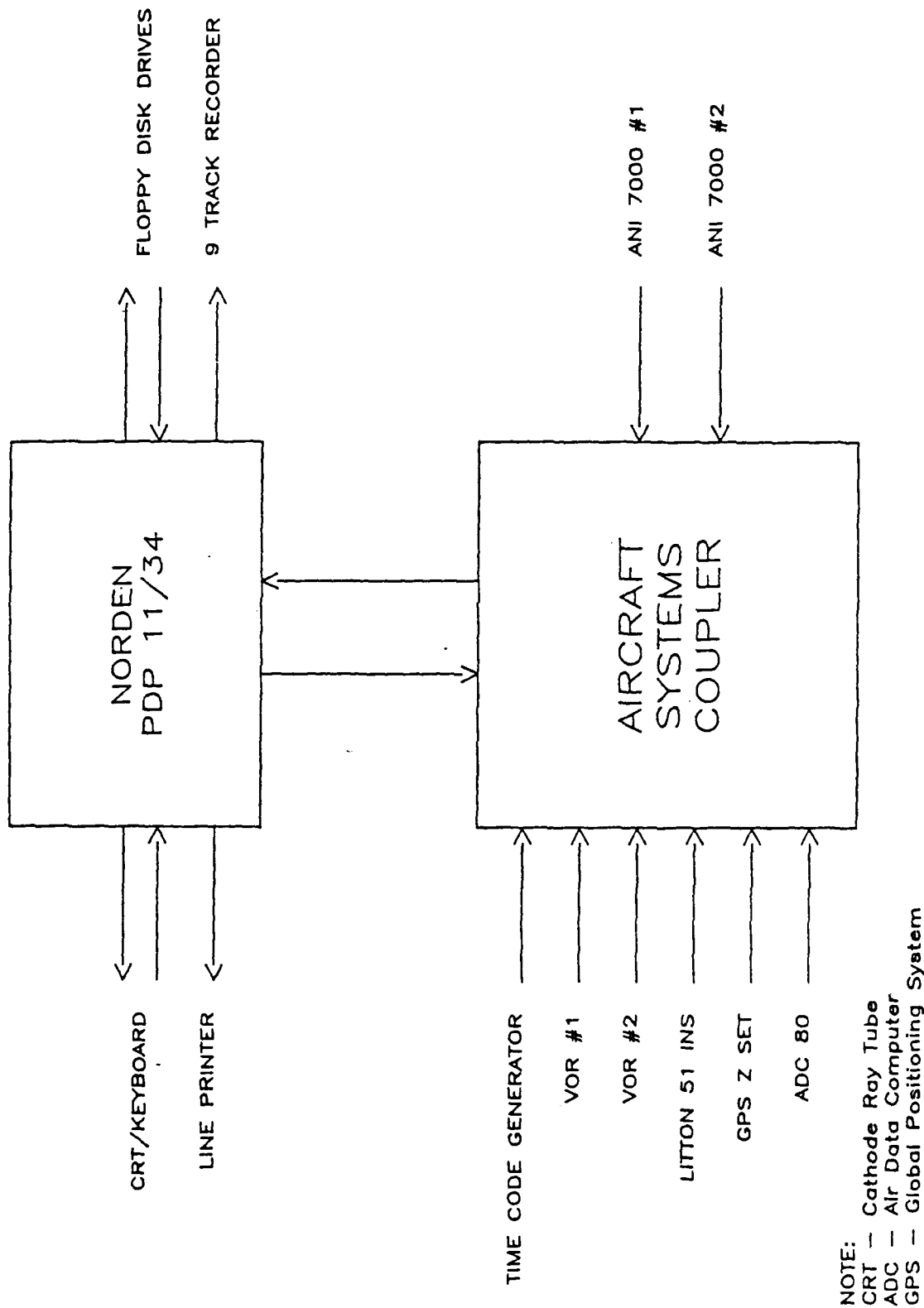

FIGURE 1. DATA COLLECTION SYSTEM

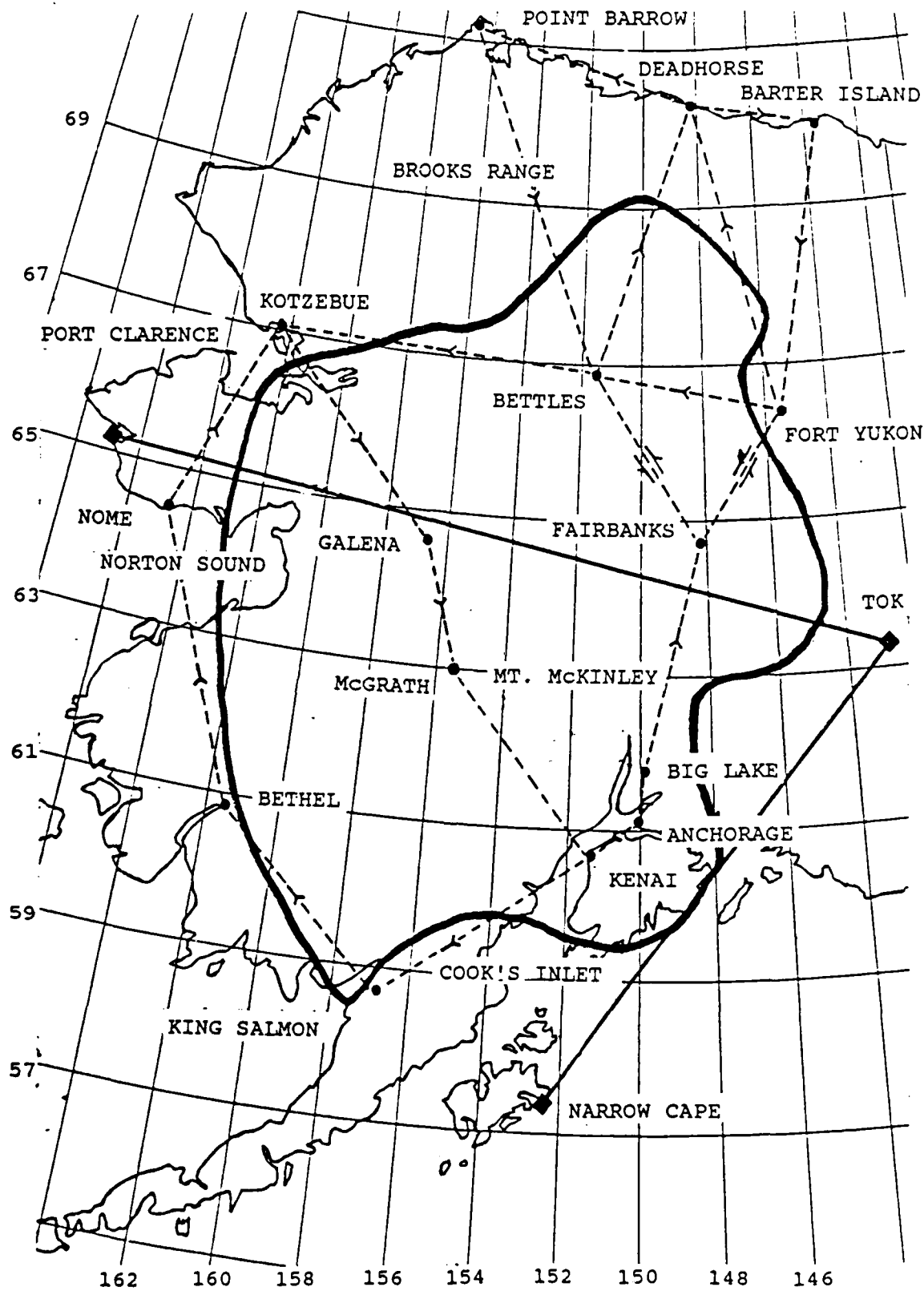

FIGURE 2. FLIGHT ROUTE

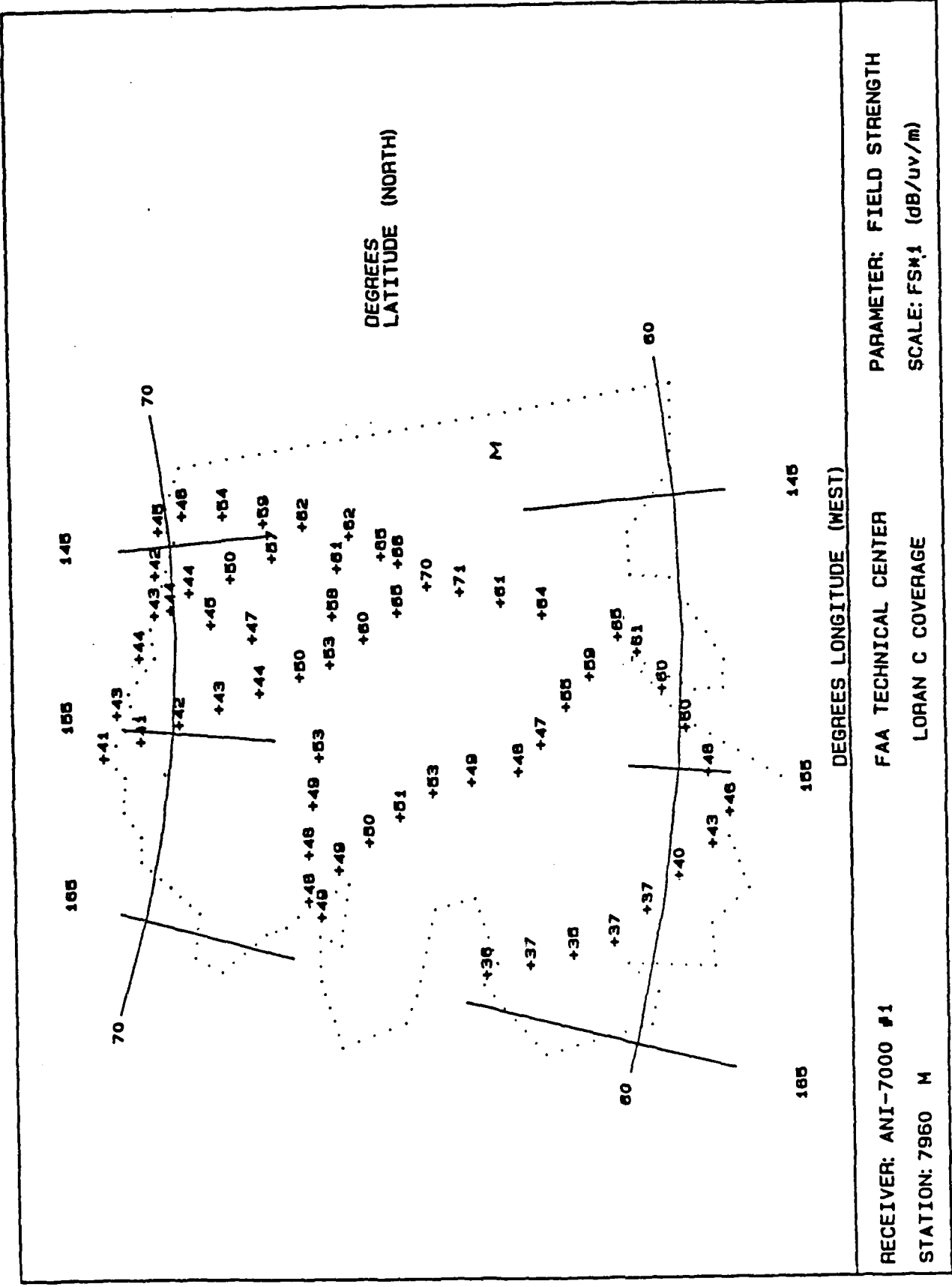

FIGURE 3. FIELD STRENGTH FOR TOK

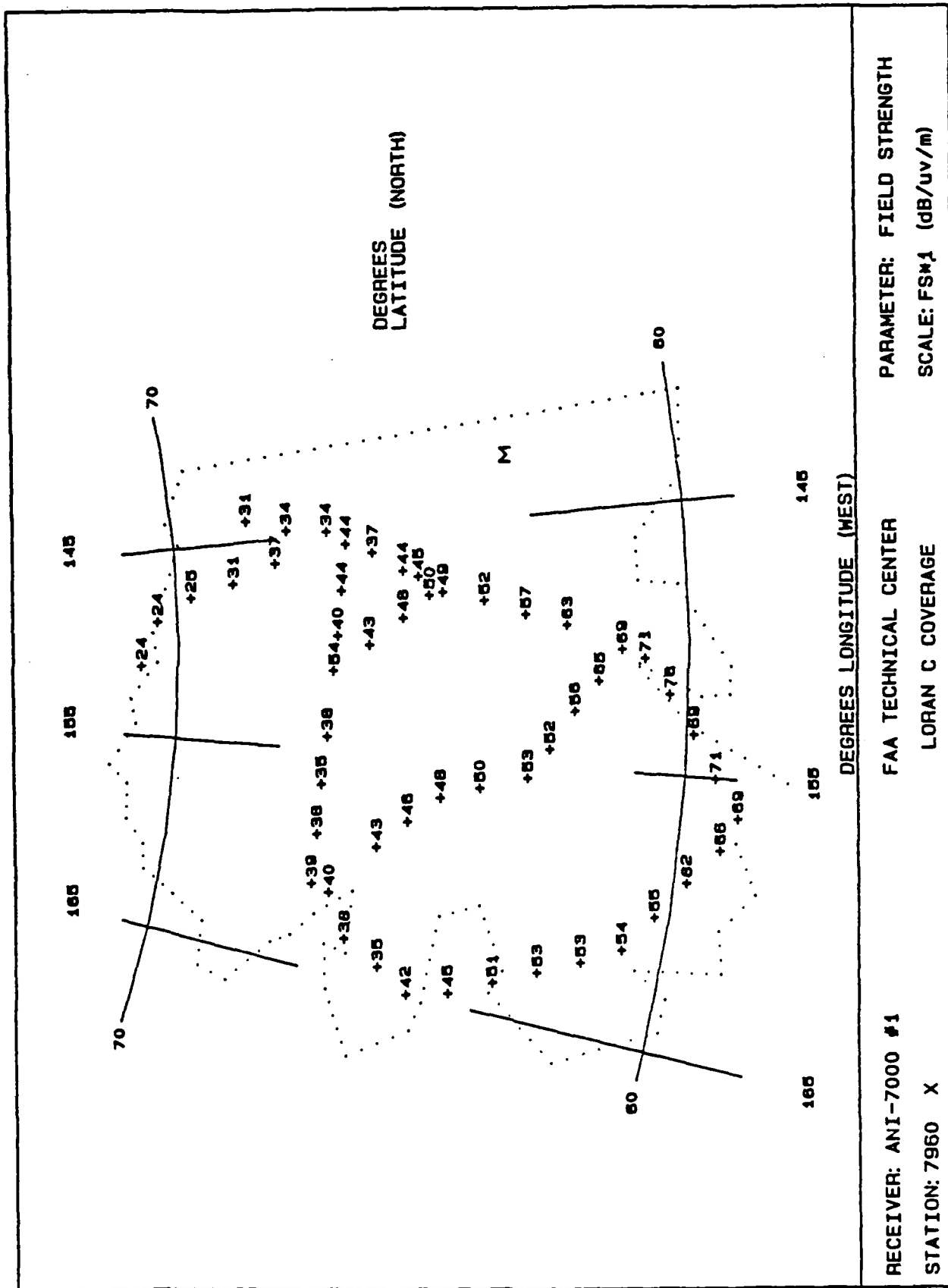

FIGURE 4. FIELD STRENGTH FOR NARROW CAPE

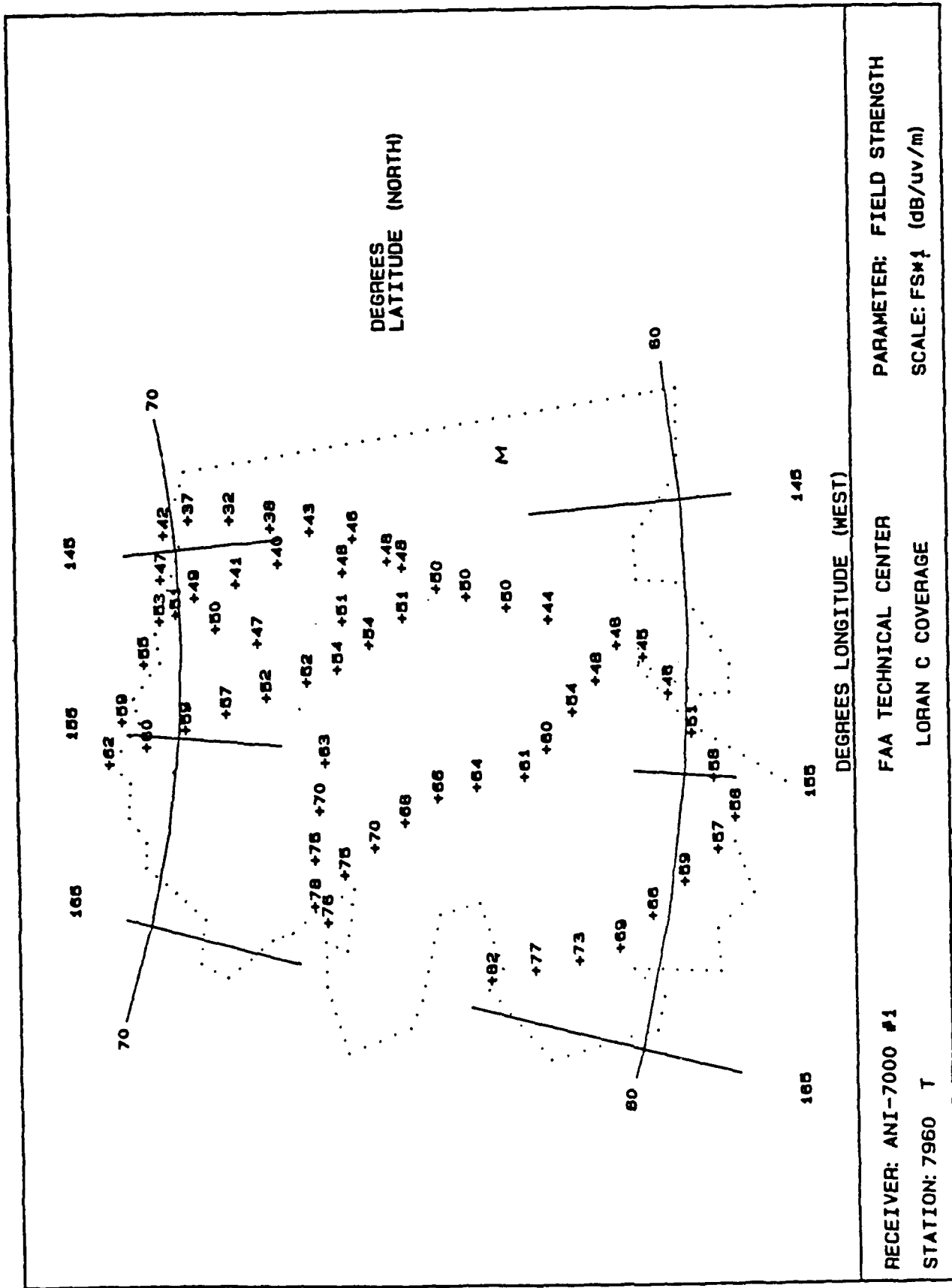

FIGURE 5. FIELD STRENGTH FOR PORT CLARENCE



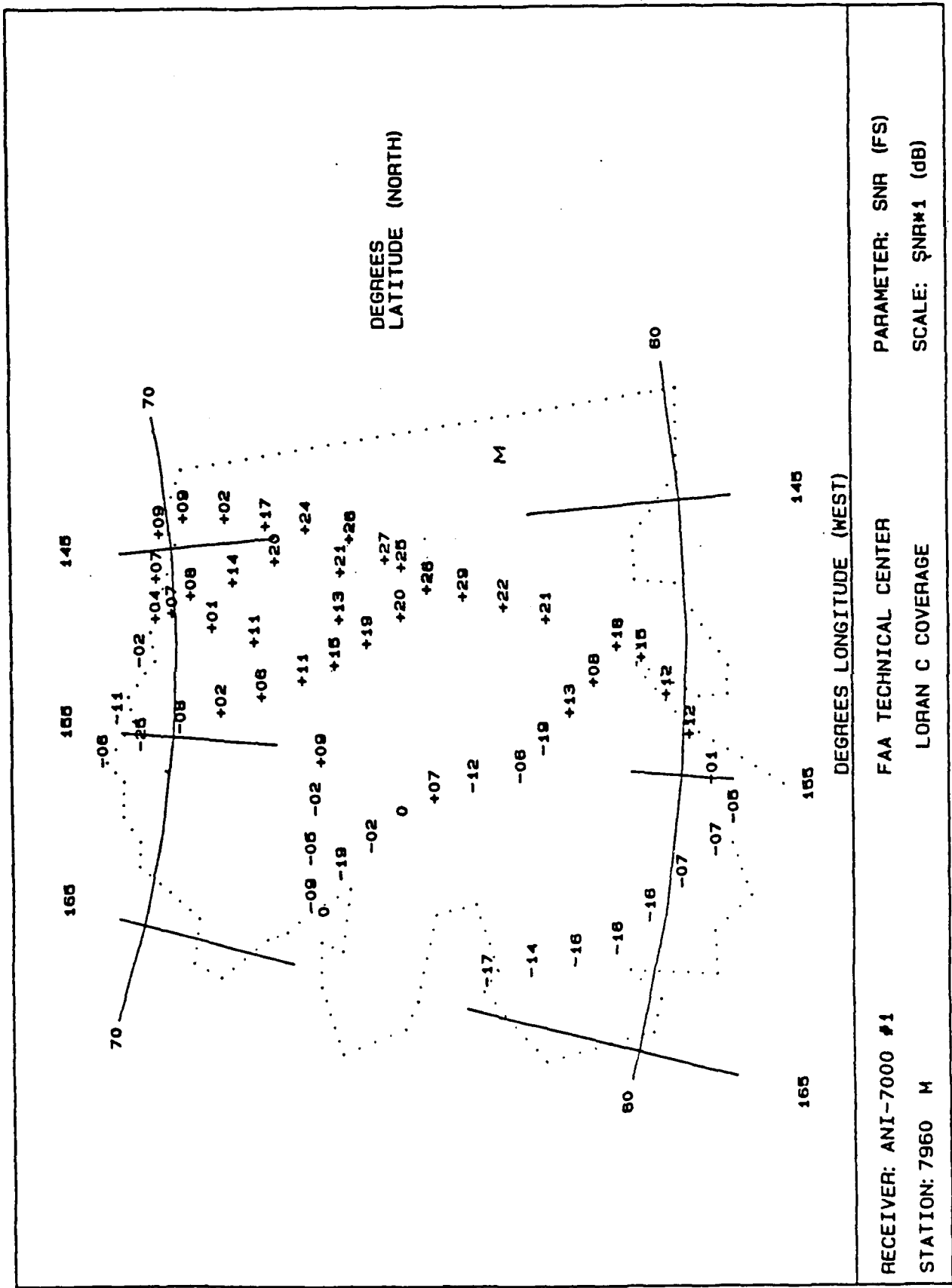

FIGURE 7. SNR(FS) FOR TOK

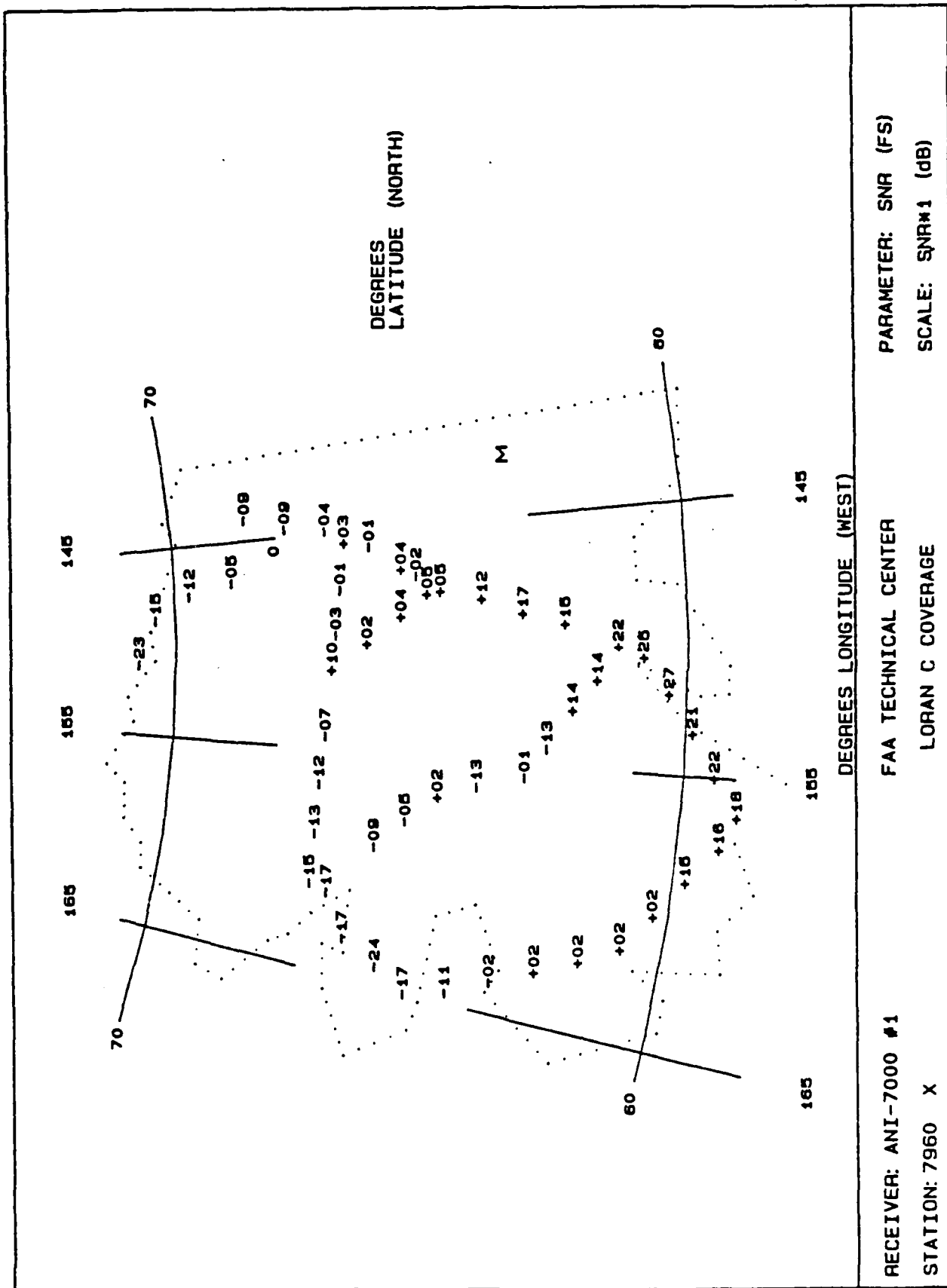

FIGURE 8. SNR(FS) FOR NARROW CAPE

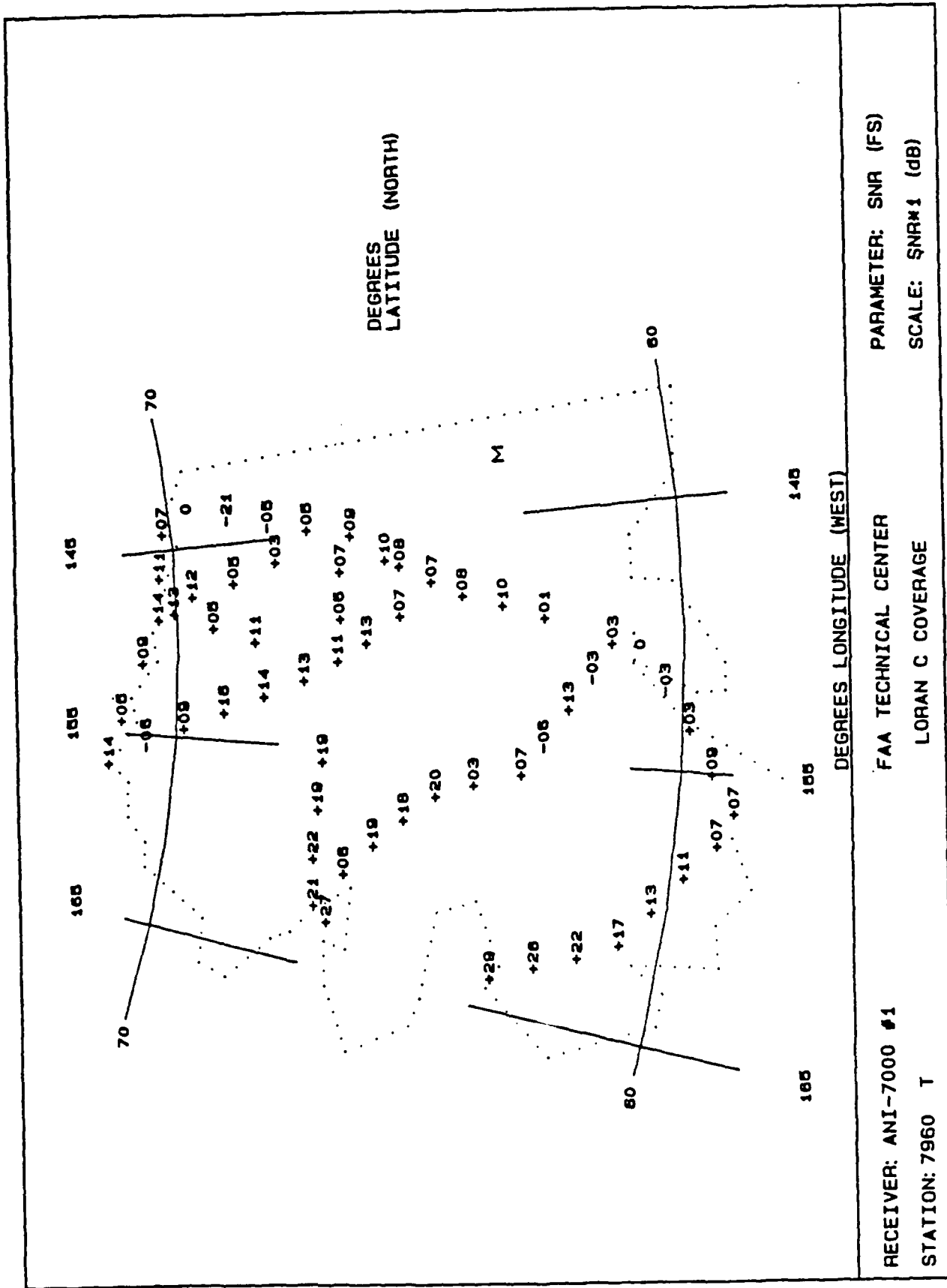

FIGURE 9. SNR(FS) FOR PORT CLARENCE

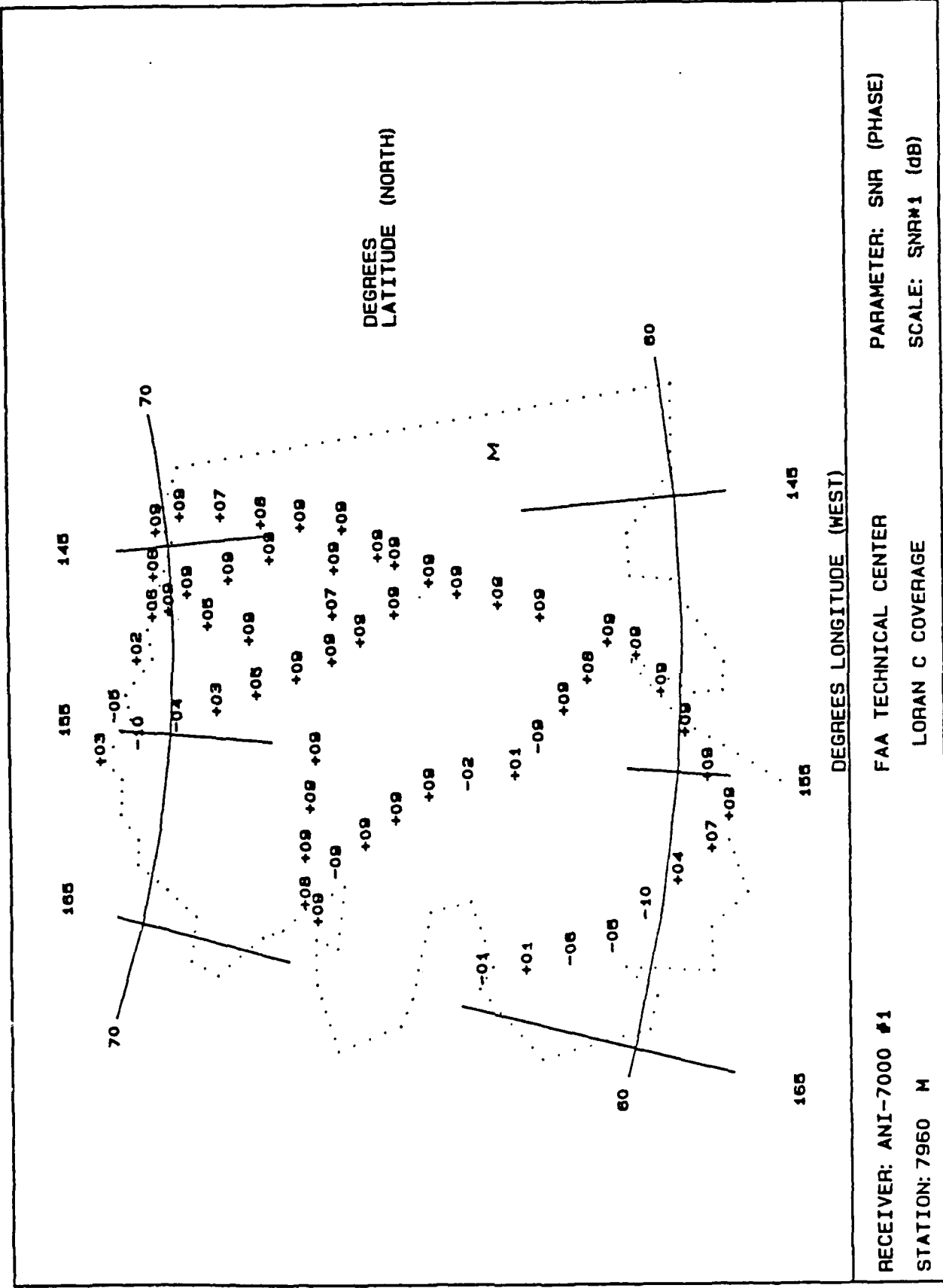

FIGURE 10. SNR(PH) FOR TOK

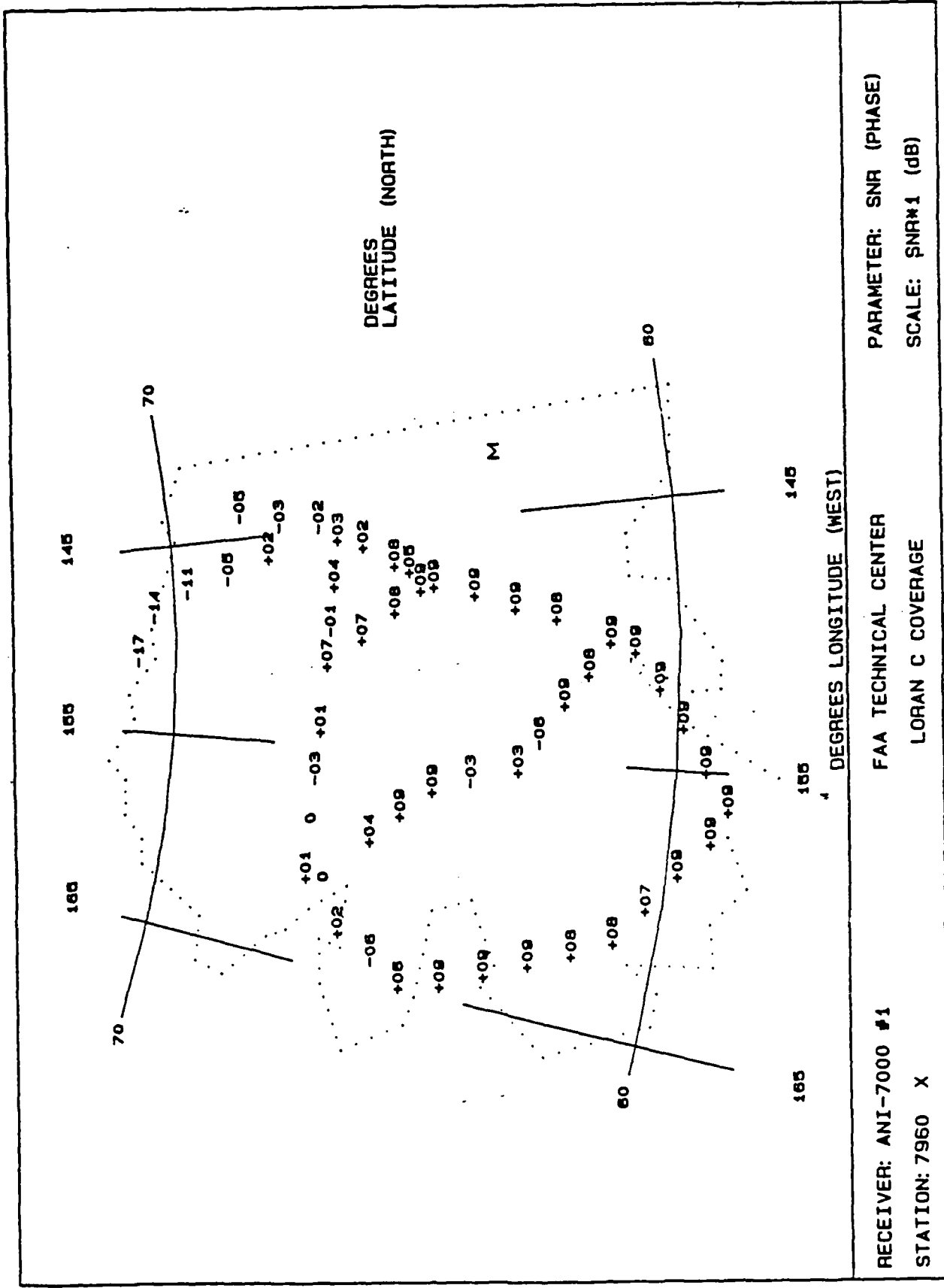

FIGURE 11. SNR(PH) FOR NARROW CAPE

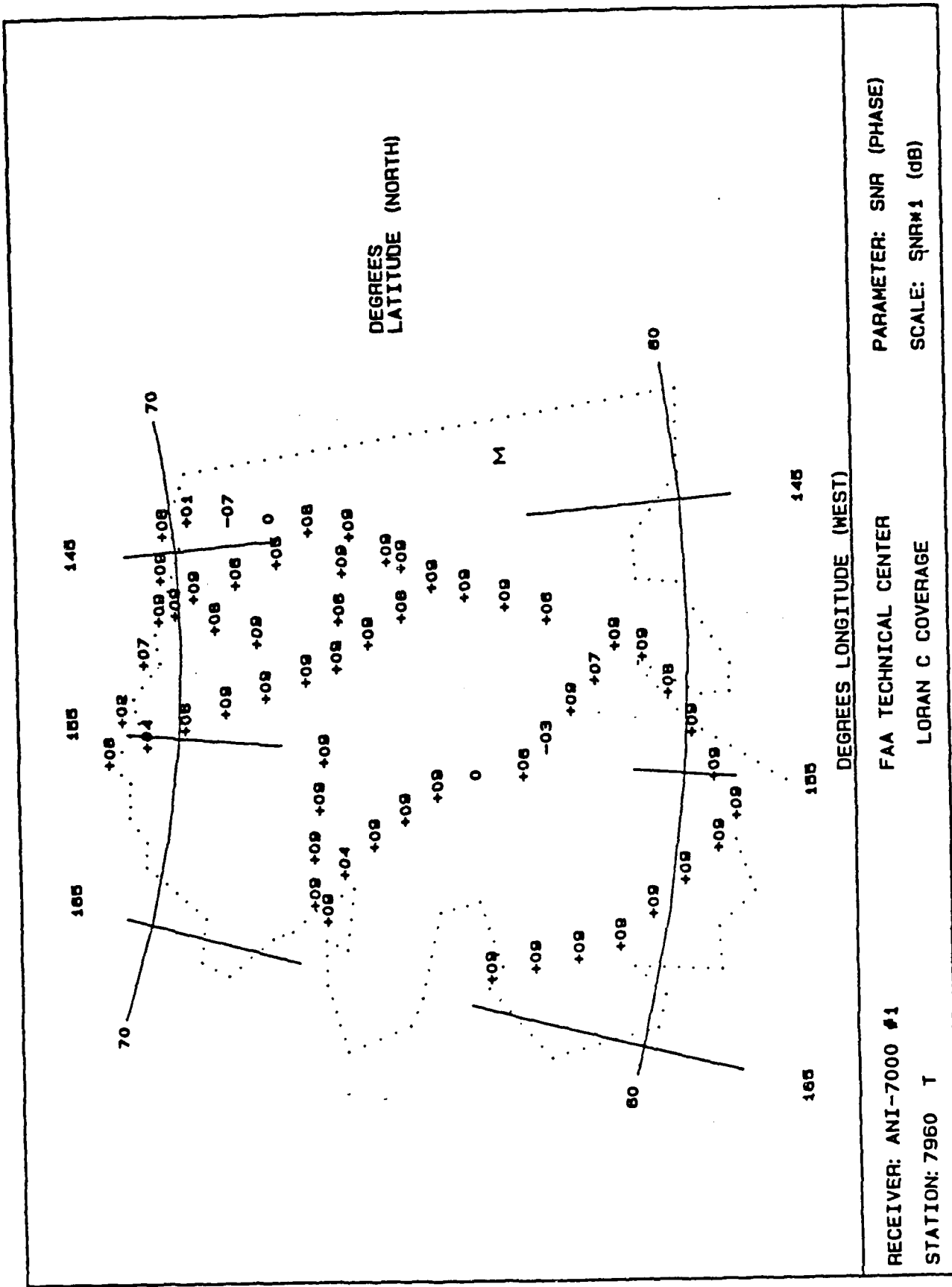

FIGURE 12. SNR(PH) FOR PORT CLARENCE

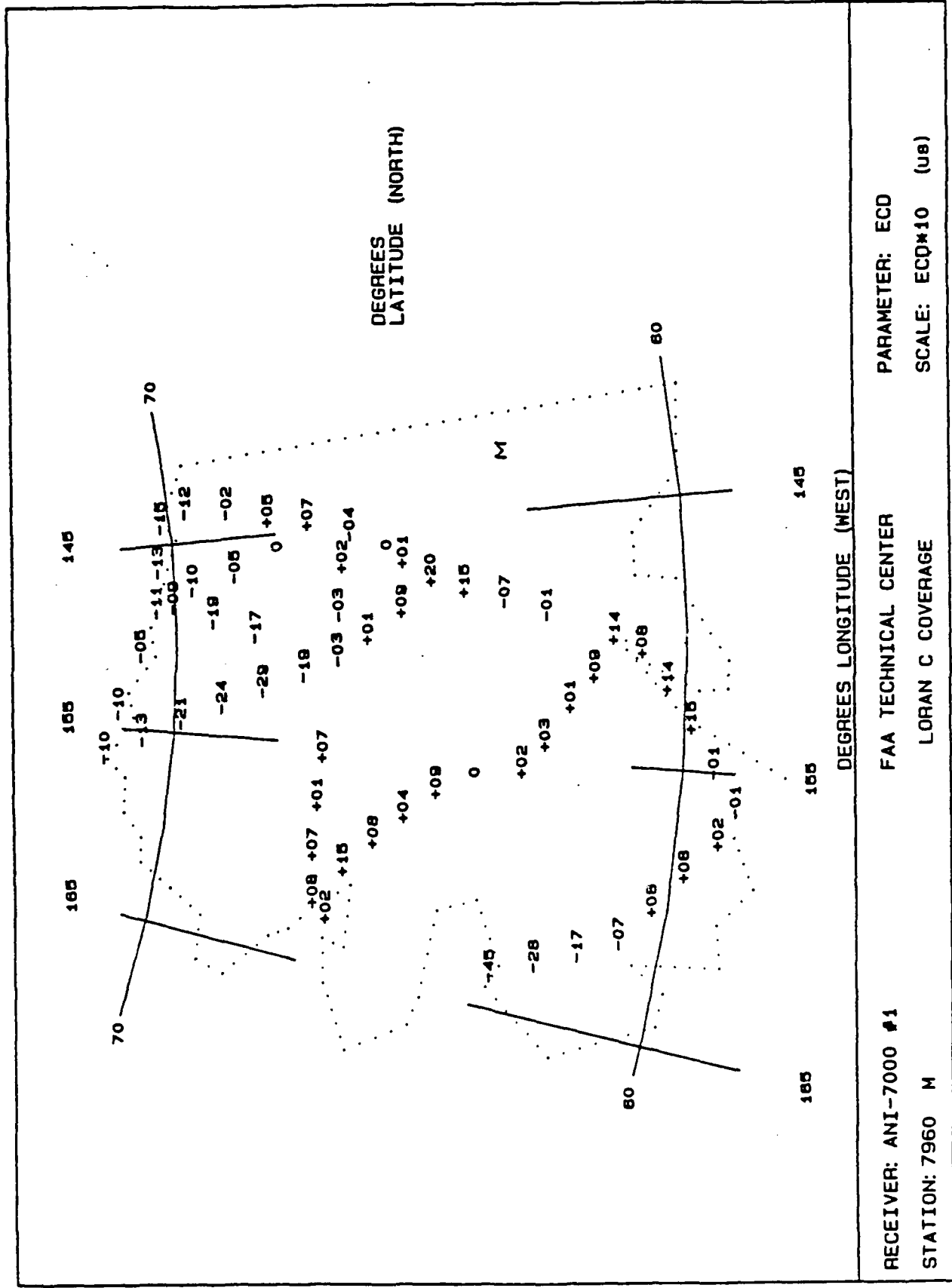

FIGURE 13. ECD FOR TOK

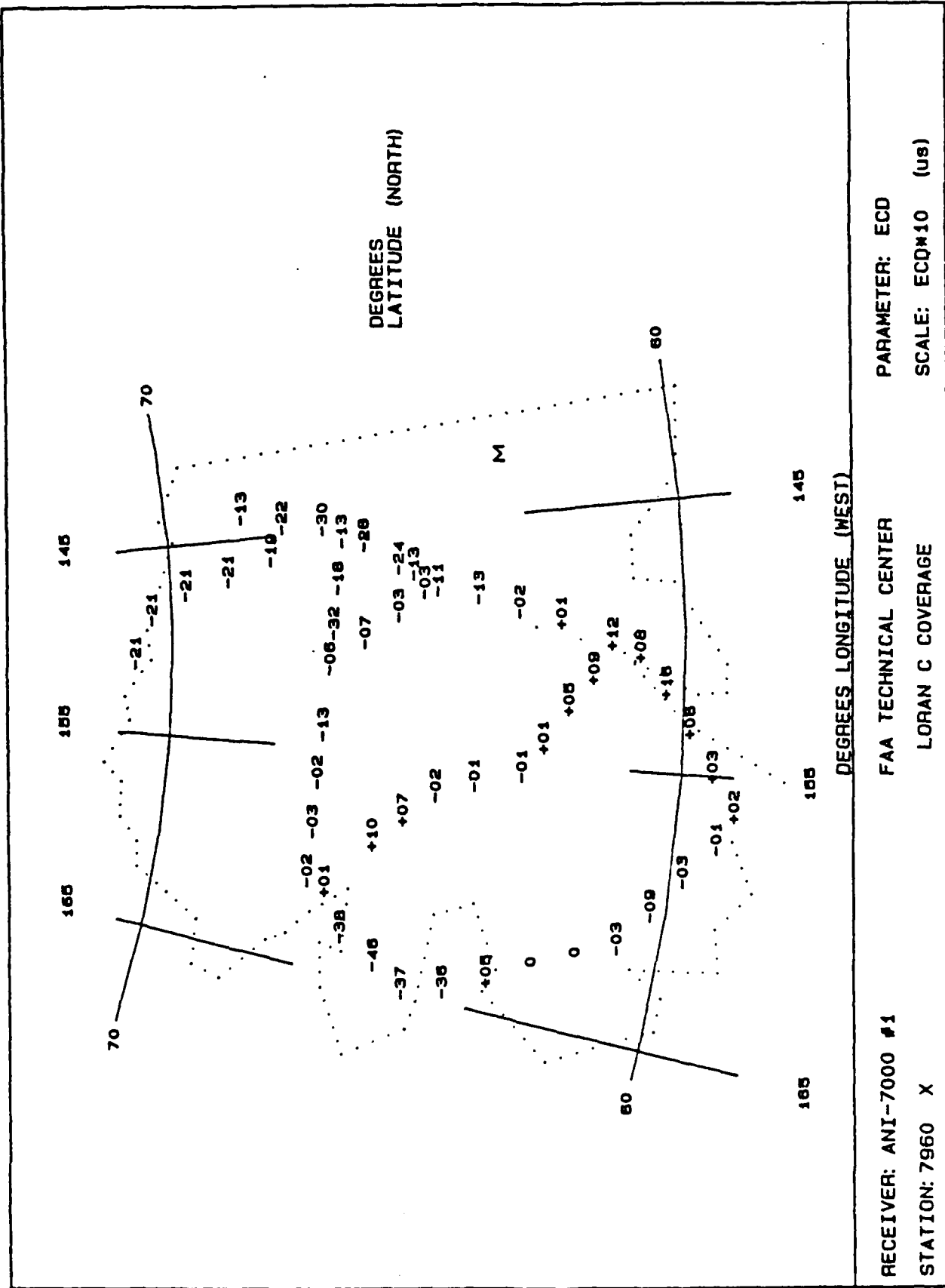

FIGURE 14. ECD FOR NARROW CAPE

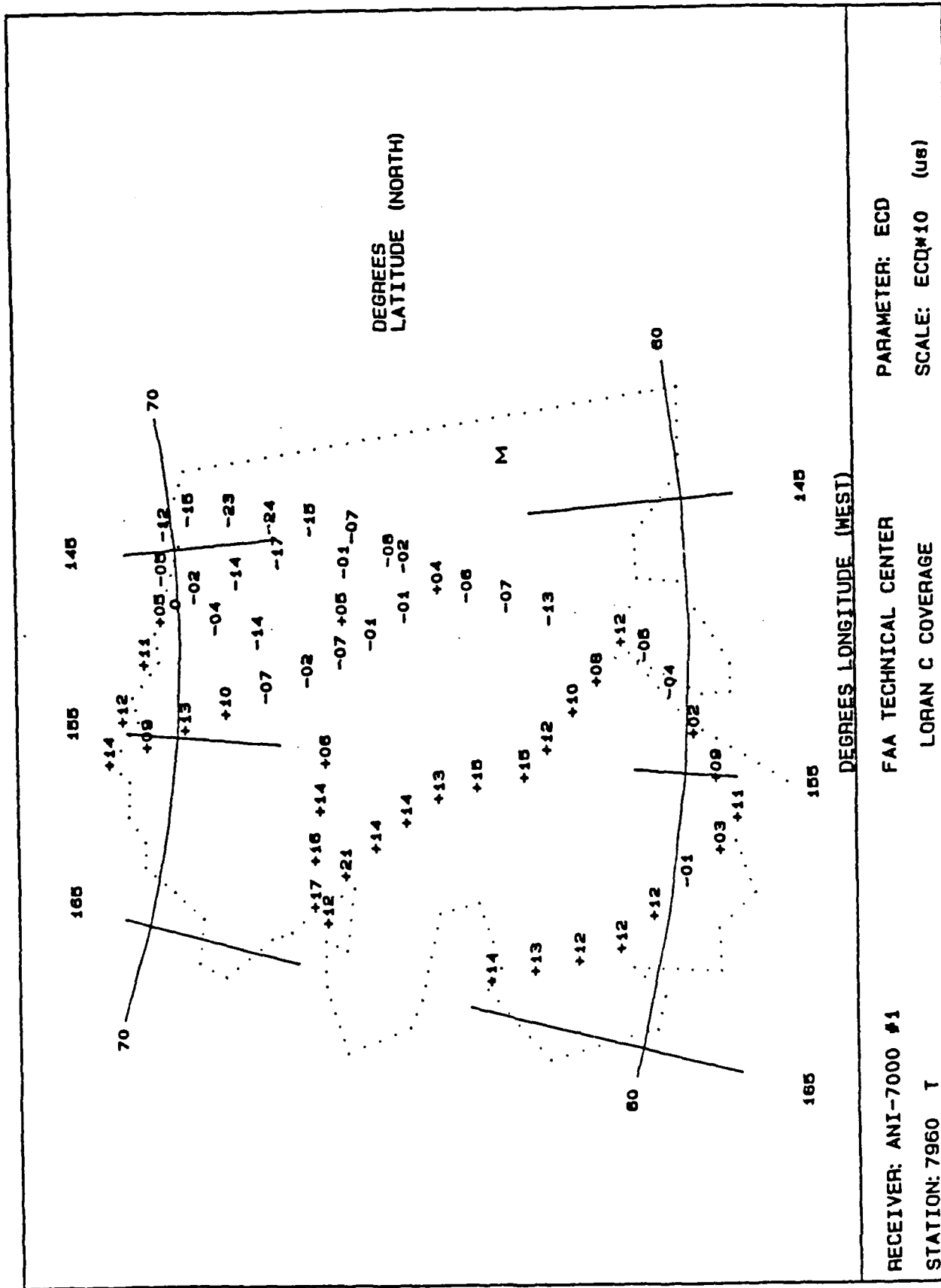
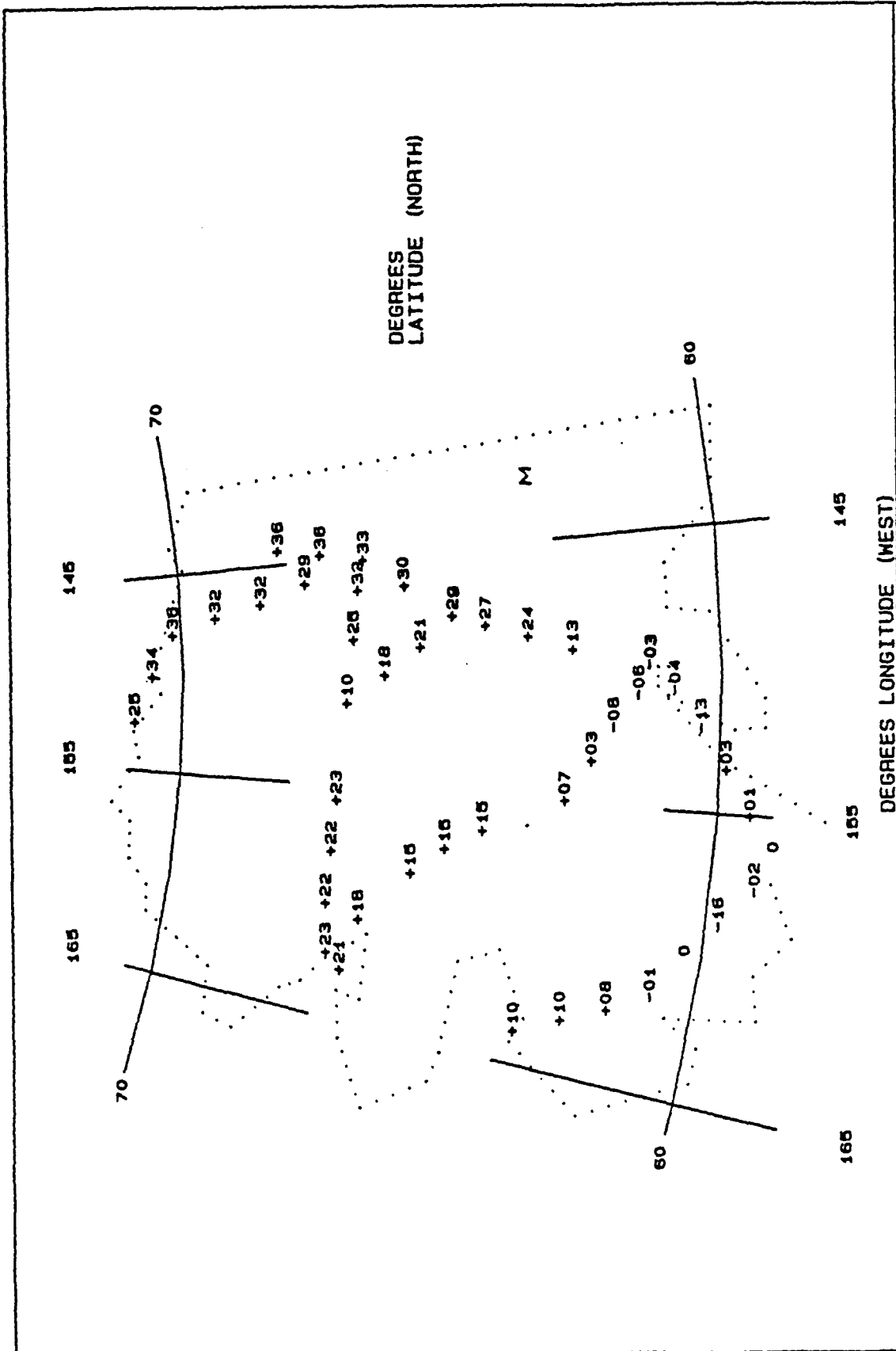

FIGURE 15. ECD FOR PORT CLARENCE



RECEIVER: ANI-7000 #1  
 LOP: 7960 MX  
 FAA TECHNICAL CENTER  
 LORAN C COVERAGE  
 PARAMETER: TD BIAS  
 SCALE: TD\*10 (US)

FIGURE 16. TD BIAS FOR MX

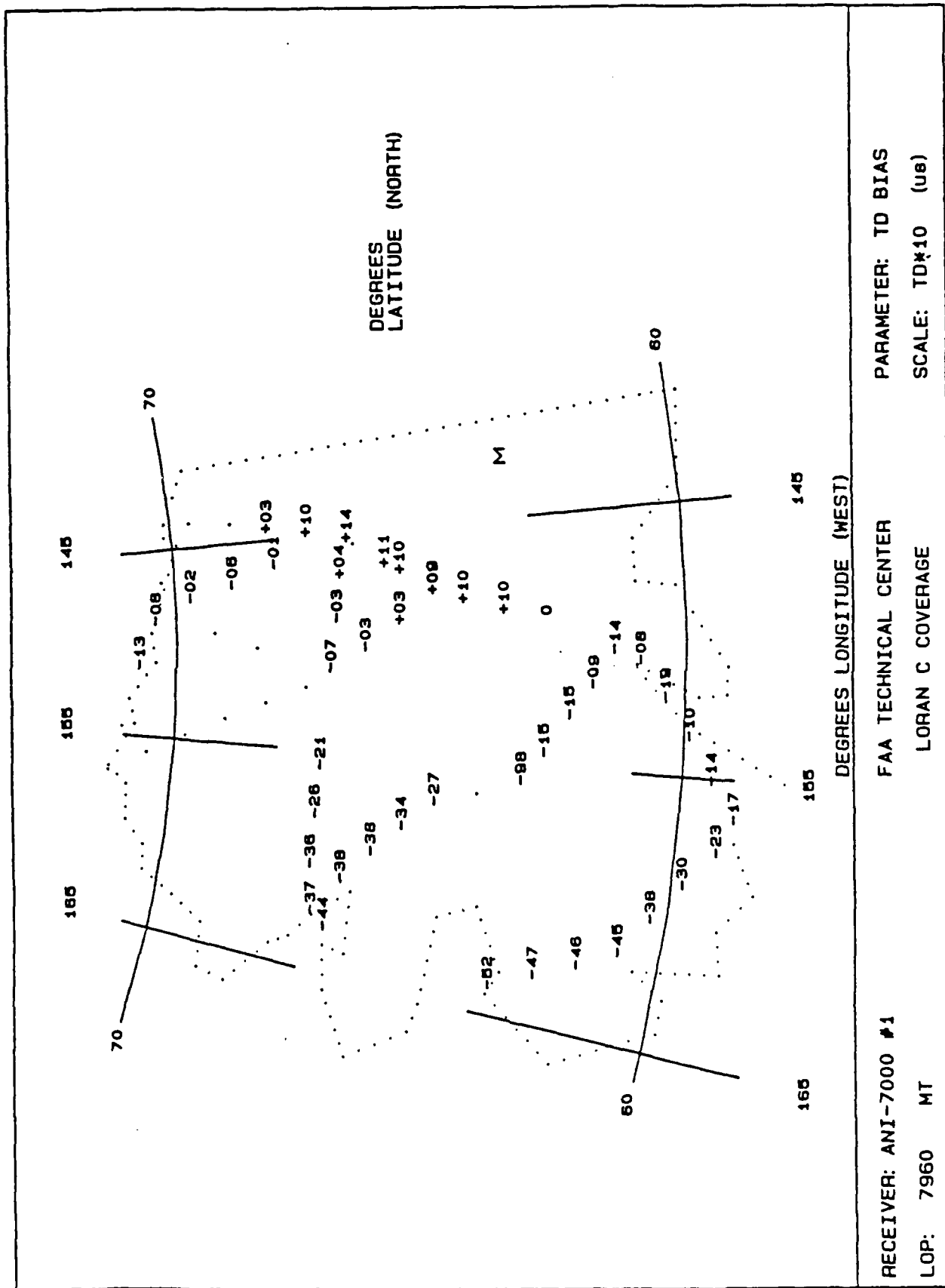

FIGURE 17. TD BIAS FOR MT

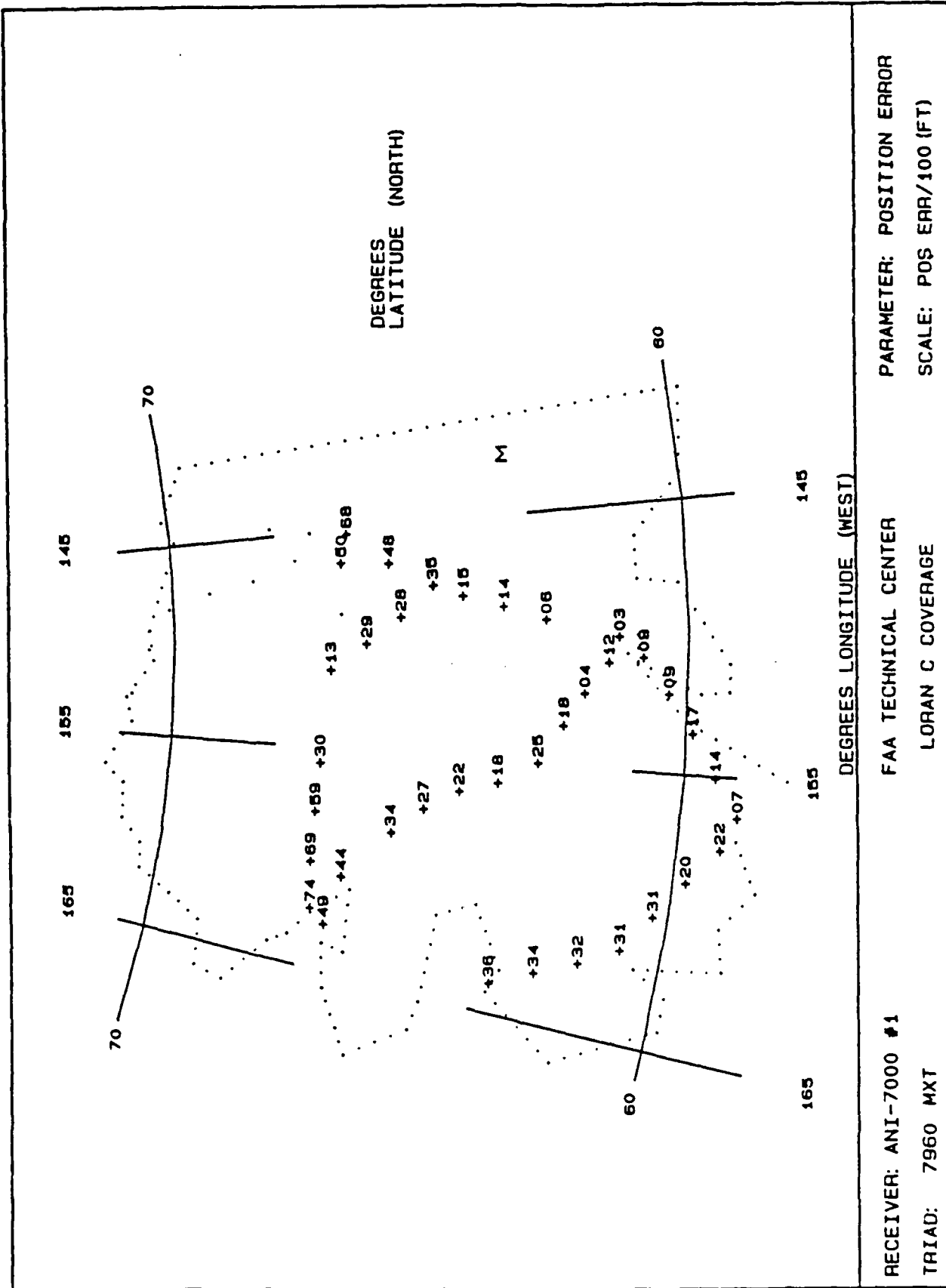

FIGURE 18. POSITION SHIFT

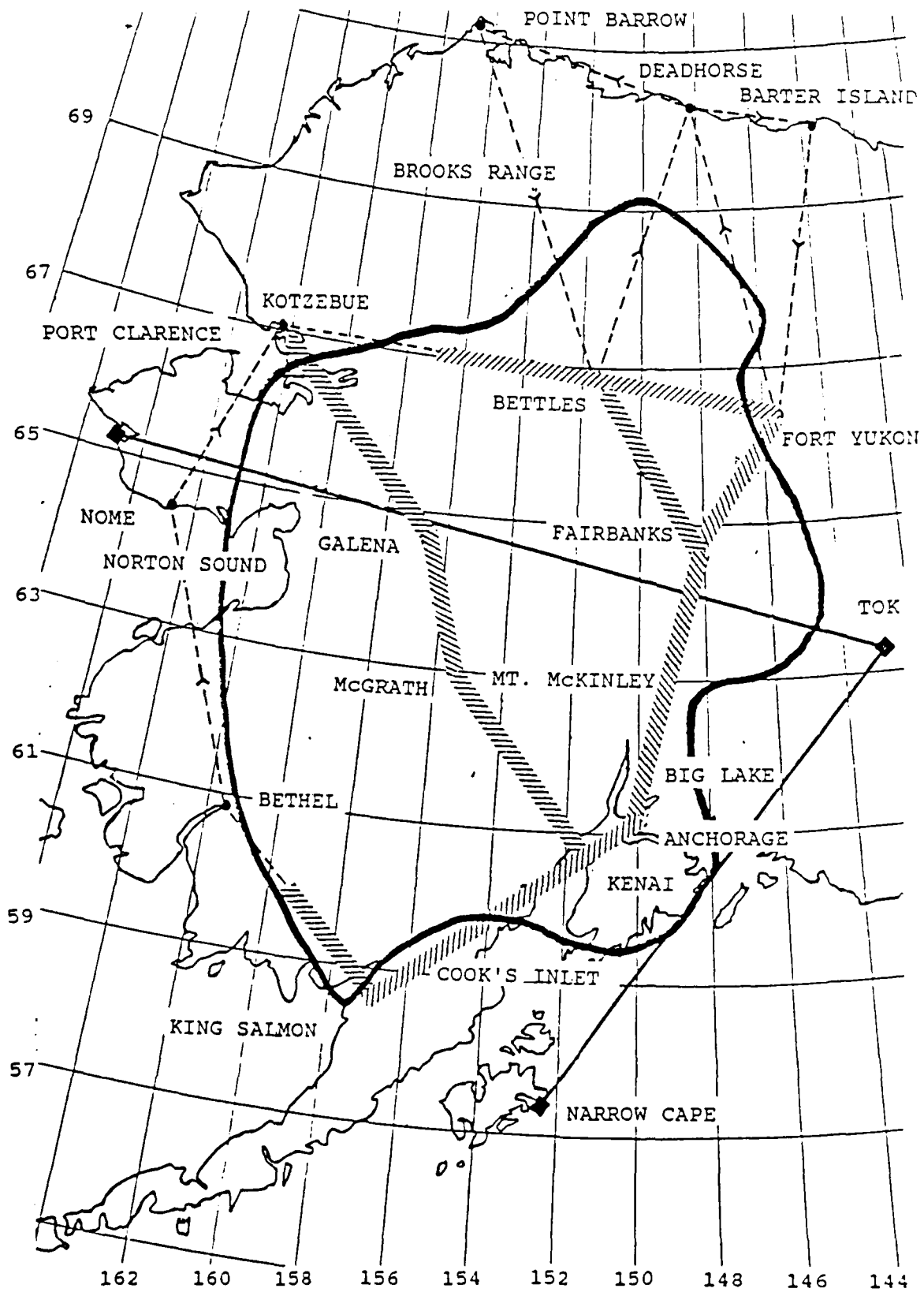

FIGURE 19. SUMMARY OF LORAN C COVERAGE FROM FLIGHT TESTS

## APPENDIX

### EQUATIONS AND CONSTANTS

#### GREAT CIRCLE DISTANCES.

The calculation of great circle distances was needed in the time difference equations. Equations can be found in Advisory Circular (AC) 90-45-A appendix J (Related Documentation number 4). These mathematical formulas are known as Sodano's method. The following constants representing the World Geodetic System 1972 (WGS-72) were used for the reference ellipsoid instead of those for the North American Datum 1927 (NAD-27). WGS-72 constants are used by the Loran C community to calculate Loran C receiver positions. All Loran C transmitters are defined in WGS-72 coordinates.

Earth flattening:

$$F = 1/298.26$$

Semimajor axis of the earth:

$$A_0 = 6378135 \text{ meters} = 3443.91049 \text{ nmi}$$

$$1 \text{ meter} = 3.280840 \text{ feet}$$

$$1 \text{ nmi} = 6076.1155 \text{ feet}$$

#### TIME DIFFERENCES (TD's).

The following equations were used to compute TD's at a given geodetic position. The method uses the same constants as the DMA seawater model, but the secondary phase delay has been converted to use distances in nautical miles (nmi) instead of in microseconds.

$$TD = (TS + DELTS) - (TM + DELTM) + ED$$

where:

TD = time difference at a given geodetic point P

TS = distance in microseconds from point P to the secondary

TM = distance in microseconds from point P to the master

DELTS = secondary phase delay in microseconds from point P to the secondary

DELTM = secondary phase delay in microseconds from point P to the master

ED = Nominal emission delay in microseconds as published by the USCG. In reality, ED of a secondary is changed to maintain a control TD at the SAM. Early equations used baseline length and coding delay in the equations but is equivalent to emission delay.

$$TM \text{ or } TS = D * v/c$$

where:

- D = great circle distance between the Loran C transmitter and point P
- v = index of refraction = 1.000338
- c = free space velocity = 0.299792458 km/microseconds
- v/c = 3.336768 microseonds/km = 6.179707 microseonds/nmi

DELTM or DELTS:

1. For great circle distances greater than 86.9 nmi  
 $= Co/D + C1 + C2 * D$

where: Co = 20.8820  
 C1 = -0.40758  
 C2 = 0.0039906

2. For great circles distances less than 86.9 nmi  
 $= Do/D + D1 + D2 * D$

where: Do = 0.443597  
 D1 = -0.011402  
 D2 = 0.002025

TD'S.

TD bias is defined as the difference between the measured TD at a location and the TD calculated using the above equations. TD bias is positive if the measured TD is greater than the predicted value.

POSITION ERROR.

A full explanation of the equations can be found in Loran C Signal Stability Study: St. Lawrence Seaway report (Related Documentation number 5). The basic equations were:

$$\begin{bmatrix} DE \\ DN \end{bmatrix} = -v * \begin{bmatrix} \sin(B1)-\sin(BM) & \cos(B1)-\cos(BM) \\ \sin(B1)-\sin(BM) & \cos(B2)-\cos(BM) \end{bmatrix} -1 \begin{bmatrix} DTD1 \\ DTD2 \end{bmatrix}$$

where:

- DE = shift in position in easterly direction
- DN = shift in position in northerly direction
- v = propagation of the signal = 983.2 feet/microsecond
- BM = true bearing from observation point to the master
- B1 = true bearing from observation point to secondary 1
- B2 = true bearing from observation point to secondary 2
- DTD1 = time difference bias for LOP 1
- DTD2 = time difference bias for LOP 2

### GREAT CIRCLE BEARING CALCULATIONS.

A full explanation of the equations can be found in "Loran C Signal Stability Study: St. Lawrence Seaway Report" (Related Documentation number 5). This set of equations assumes the earth is a perfect a sphere. The basic equations were:

$$E = \cos(La2) * \sin(Lo2 - Lo1)$$

$$F = \sin(La2) * \cos(La1) - \sin(La1) * \cos(La2) * \cos(Lo2 - Lo1)$$

$$H = \text{inv tan } (E/F)$$

If:

1. Observer is south and west of the transmitter  
B = H
2. Observer is north and west of the transmitter  
B = H + 180°
3. Observer is south and east of the transmitter  
B = H + 360°
4. Observer is north and east of the transmitter  
B = H + 180°

where:

La1 = latitude of the observer

Lo1 = longitude of the observer

La2 = latitude of the transmitter antenna

Lo2 = longitude of the transmitter antenna

B = great circle bearing from the observer  
to the transmitter