

AD-A196 065

ROYAL AIRCRAFT ESTABLISHMENT

Technical Memorandum IT 212

Received for printing 11 January 1988

A GUIDE TO GOOD MAGNETIC TAPE MANAGEMENT
PRACTICE FOR MODAS USERS

by

M. J. Broad

SUMMARY

This Memorandum gives some background information on the magnetic recording process employed in a Modular Data Acquisition System (MODAS) for use in harsh airborne environments, and highlights some of the more important problems encountered in producing an acceptable low error rate digital pcm recording. Advice is given on magnetic tape handling and storage which is generally applicable to high density tape recording. Also, methods of optimising the equalisation of the MODAS ground replay system are described so that users can ensure that the complete system is operating to full performance at all times.



Copyright
©
Controller HMSO London
1988

Accession For	
NTIS CRA&I	<input checked="" type="checkbox"/>
DTIC TAB	<input type="checkbox"/>
Unannounced	<input type="checkbox"/>
Justification	
By	
Distribution/	
Availability Codes	
Dist	Avail and/or Special
A-1	

LIST OF CONTENTS

	<u>Page</u>
1 INTRODUCTION	3
2 A DISCUSSION ON MODAS BASED MAGNETIC TAPE RECORDING AND REPLAY	3
2.1 General	3
2.2 Head/tape interface	5
2.2.1 Physical	5
2.2.2 Electro-magnetic	6
2.3 Head problems	8
2.3.1 Misalignment	8
2.3.2 Contamination	9
2.3.3 Head wear	9
2.3.4 Magnetisation	10
2.4 Tape problems	10
2.4.1 Contamination	10
2.4.2 Tape erasure	10
2.4.3 Tape handling	11
2.4.4 Tape storage	12
3 CHOICE OF PCM CODES	12
3.1 General	12
3.2 Bi-phase code	13
3.3 Miller-squared code	13
4 EQUALISATION OF THE REPRODUCE AMPLIFIERS	14
4.1 Need for equalisation	14
4.2 Optimisation of record current	14
5 SOME METHODS FOR OPTIMISING THE EQUALISATION OF REPRODUCE AMPLIFIERS	14
5.1 Eye patterns	14
5.2 Transition distribution analysis	15
6 CONCLUSIONS	17
Appendix Conversion factors	19
References	20
Illustrations	Figures 1-19
Report documentation page	inside back cover

1 INTRODUCTION

Modern aircraft data acquisition systems such as MODAS (Modular Data Acquisition System) employ harsh environmental recorders (HER) to record data on to magnetic tape. Digital pulse code modulation (pcm) techniques and multi-track recording¹ are used by MODAS to record the data directly on to the tape. The pcm codes used are Bi-phase (Bi- ϕ) or Miller-squared (M^2). HER machines are precision equipment and are made as small as possible to fit into the often restricted space in aircraft. Because of this, tape carrying capacities are limited, and the need for high packing density recording is important so that useful recording durations can be attained.

Good recordings, with low error rates, can only be realised by using airborne recorders such as HER which have been correctly set up for the pcm code required and it is essential that the headstacks and tape path be kept meticulously clean. Also careful tape handling is important.

The recordings are replayed on an Ampex 3030 tape transport which forms part of the MODAS ground replay system. Here good equalisation is necessary to recover the data and to keep the error rate to a minimum. The data recovery electronics uses error correction techniques² that can cope with burst errors contained in any single track.

The purpose of this Memorandum is to highlight some of the more important problems encountered in producing an acceptable digital pcm recording and to give advice on good tape management practice. Methods are also described for optimising the equalisation of the Ampex reproduce amplifiers.

The units for tape and head dimensions, tape speeds, etc described in the text are imperial. The Appendix contains an appropriate list of conversions from imperial measure to metric.

2 A DISCUSSION ON MODAS BASED MAGNETIC TAPE RECORDING AND REPLAY

2.1 General

MODAS is a data acquisition and recording system which can record up to 4096 parameters on magnetic tape, using time-division multiplexing, with a range of sampling rates up to a maximum of 131 kword/s (1.8 Mbit/s of data) at present, extending to 512 kword/s (approximately 8 Mbit/s of data) in the near future. To cope with these data rates and maintain a useful duration of recording, high data packing densities are necessary (see below). For example, the recording duration of an HER 400 type recorder on a single pass at a tape speed of

15/16 inches per second (ips) and a data rate of 8 kword/s is approximately 2½ hours, and for a tape speed of 15 ips and a data rate of 131 kword/s it is approximately 9 minutes.

The MODAS recorders are normally fitted with either one or two 14-track headstacks for RECORD only. These record heads comply with the IRIG Wideband 2 specification³. When two headstacks are available the individual tracks are effectively interleaved to produce a 28-track format, odd numbered tracks on one headstack and even numbered tracks on the other. Combinations of 7 or 14 record tracks can in fact be fitted depending on the requirements. Thus the duration can be increased by the use of track switching.

Track switching involves two or more passes of the tape, in both the forward and reverse direction. The record signals are switched to the appropriate group of track-heads on change of direction of the tape. The track switching is controlled by the detection of transparent windows at each end of the tape. The track switching concept and available head and tape speed combinations make the MODAS recorders very flexible in the range of recording data rates and durations offered to users.

At the present time two pcm codes are used with MODAS: Bi-phase (Bi- ϕ) or Miller-squared (M^2). In the majority of trials the codes are recorded at a maximum packing density of approximately 20000 flux reversals per inch giving 10 kbit/inch for Bi- ϕ and 20 kbit/inch for M^2 . Thus there is a 2:1 advantage in using M^2 where duration of recording is important.

Data are recorded in a multi-track serial format, the samples being time-division multiplexed according to a predefined program held in the MODAS processing unit. The recorded data words are separated into groups by track synchronisation words to help recovery on replay.

The magnetic tape used is high quality instrumentation tape, 1 inch wide with an anti-static back coating.

The tape capacities of the recorders currently in use are given in Table 1 (see also the Appendix).

Table 1

Tape capacities of the HER range

HER 400/401/402	700 ft
HER 600/601	1500 ft
HER 800	2400 ft

2.2 Head/tape interface

2.2.1 Physical

(a) Record/reproduce head design

A typical core structure for a single track is shown in Fig 1. For reasons of manufacture and assembly techniques the core is made up of two identical core halves using thin laminations of a high permeability material such as μ -metal. Each half is wound with identical signal windings and the pair are assembled with non-magnetic separators front and rear. The front miniscule gap generates a fringing magnetic field to magnetise the tape in the case of the record head, or collects the tape flux in the reproduce head. The rear gap is much deeper to offer minimum reluctance to the lines of flux through the core.

To reduce the rate of wear of the head it is common practice to bond a hard magnetic alloy such as Alfesil (a mixture of aluminium, iron and silicon) to the core in the form of a head tip plate.

Gap separators of various materials have been used to control the length of the front gap. Mica has been used extensively but modern narrow-gap heads have a layer of silicon oxide. It is placed on one half of the head assembly by vacuum deposition techniques. For Wideband 2 heads the dimensions of the gap are typically 85 μ inch for record and 25 μ inch for reproduce.

The head assemblies are made in two halves to simplify manufacture and are bonded together using epoxy resin or screws or both. The head profile is then ground and lapped to its final dimensions.

Fig 2 shows the recording surface view of a 14-track headstack indicating the individual track heads and the μ -metal shields which are interleaved. The shields are necessary to reduce crosstalk between adjacent tracks. The headblock is made of aluminium alloy. Electrical connections are made at the rear of the headstack and the wires are brought out to a multi-way connector.

(b) Head/tape relationship

The head/tape relationship is illustrated in Fig 3. When recording, the current flowing through the head winding gives rise to a fringing magnetic field across the gap where most of the circuit reluctance is located. The tape, passing over the gap, is magnetised by this field and since the tape coating is of high coercivity remanent magnetisation is retained. On replay, the recorded tape is passed in the same direction across the reproduce head gap where some of the flux from the tape will induce voltages in the coil. These voltages are proportional

to the rate of change of flux and hence output is proportional to the derivative of the signal recorded on the tape, necessitating frequency equalisation during replay.

Fig 4 illustrates some typical dimensions for head gap lengths and the thickness of the record surface, back coating, and the base material for magnetic tape.

2.2.2 Electro-magnetic

(a) Frequency response of reproduce head

The frequency characteristic of a typical reproduce head is shown in Fig 5. The ideal response rising at 6 dB/octave is modified at the higher frequencies by various physical constraints. The sections below describe briefly three of the more important effects. Of these gap length loss and coating thickness loss are inherent in the design of the head and make-up of the magnetic tape respectively. Head to tape separation loss is a measure of the surface quality of the tape but contamination of the head and/or tape or damage to the tape has a similar effect.

(b) Losses affecting response

(i) Gap length loss

When a sinusoidal variation in a magnetised tape is being scanned by a reproduce head whose gap is very small compared with the recorded wavelength, the output voltage corresponds to the rate of change of the instantaneous value of the recorded magnetisation and the sinusoidal variation is reproduced but with a 90° phase shift. However, as the recorded wavelength decreases and begins to approach the reproduce gap length an averaging effect occurs. When the wavelength reduce to twice the gap length the output corresponds to only $2/\pi$ times the peak of the recorded magnetisation. As the recorded wavelength decreases still further the averaging begins to include the opposite polarity of the second half cycle and the output falls off rapidly becoming zero when the gap length and recorded wavelength are equal.

The attenuation factor A_g for gap loss is given by this simple model to be:-

$$A_g = \frac{\sin(\pi g/\lambda)}{\pi g/\lambda} \quad (1)$$

where g = gap length
 λ = wavelength of recorded signal.

This gives null points in the response for $g = \lambda, 2\lambda, 3\lambda$, etc. Westmijze⁴ has derived a more accurate expression which gives the first null point at $g = 0.89 \lambda$, thus making the effective gap length about 1.12 times its physical length. This difference has little significance in practice because of the large tolerances in physical gap length.

Between the null points the response rises to a maximum, each successive maximum being lower than the previous one, the rate of fall being about 4 dB/octave, as shown in Fig 5.

(ii) Separation or spacing loss

Because of the extremely short excursions of the flux from the surface of the tape as the wavelength decreases, any separation of the tape from the head surface will result in a degradation of the recovered signal output.

The loss is often expressed in dBs and is quoted as the "Wallace Formula"⁵. The attenuation factor A_s , when reproducing signals from the tape, is given as:

$$A_s = 54.6 s/\lambda \text{ dB} \quad (2)$$

where s = separation
 λ = wavelength of recorded signal.

As a practical example of the separation loss, a Bi- ϕ recording of 10 kbp/s produces wavelengths of 100 μ inch minimum; therefore an attenuation of 6 dB would result from a separation of only 11 μ inch. Smoke particles are of the order of 20 μ inch!

The same order of loss of signal can occur at a replay speed of 120 ips due to tape separation resulting from the tape floating on a layer of air carried over the head by the tape.

(iii) Coating thickness loss

As the recorded wavelength decreases, the magnetised layers of the tape coating further from the replay head make a decreasing contribution to the total reproduced signal. The effect is similar to the spacing loss mentioned previously but is complicated by phasing between layers. The attenuation factor A_t is⁴:

TM IT 212

$$A_t = \frac{1 - e^{-2\pi t/\lambda}}{2\pi t/\lambda} \quad (3)$$

where t = coating thickness.

Again, for a Bi- ϕ recording of 10 kbpi, producing a wavelength of 100 μ inch, and a tape coating thickness typically of 200 μ inch, the attenuation factor due to this effect is 0.08 or -22 dB.

2.3 Head problems

2.3.1 Misalignment

(a) Height

This is not normally a user problem with the heads themselves unless there has been an error in manufacture. The headstacks are mounted on precision head-plates and the head-plate assemblies are themselves precisely located in the recorder or replay machine. The MODAS replay system has to cope with tapes produced from a number of different recorders, therefore all heads and head-plates are finely toleranced to be compatible. Any height problem is more likely to be associated with the tape and its guidance past the heads.

Individual reels of magnetic tape are slit from a wider length called the web, and although the cut is precise there is a possibility of slight weaving of the web as the cut is made. One manufacturer has quoted a figure of 0.125 inch weave or curvature per 48 inch of length which can produce a 0.010 inch misalignment for a 4 inch length. This length is close to the distance between the capstans of an HER deck so there could be a track offset approaching 0.010 inch. Track widths for both record and reproduce heads are 0.025 inch, so a reduction in signal of about 40% is possible.

Generally speaking tapes are produced to a much better tolerance than this but occasionally a reel may be encountered which reached the limit of production specification.

(b) Gap scatter

An example of gap scatter is shown in Fig 6. It is defined as the minimum distance between two parallel lines, in the plane of the tape, between which all the gap trailing edges in a record head fall. The effect is to cause the data bits which are recorded simultaneously on the tape to be physically displaced in proportion to the gap scatter. This is also known as intertrack time displacement error (ITDE). Again with new equipment this is not a user problem,

tolerances will have been checked during manufacture. However, displacement of gaps from the manufactured positions as a result of temperature cycling, particularly in harsh temperature environments, can sometimes cause a rapid deterioration in head performance.

(c) Azimuth

This is shown in Fig 7. If a multi-track recording is made with minimum gap scatter, the head gaps being at 90° to the tape, and then replayed on a head which is set at an angle other than 90° there will be a mean static skew of the tracks to be added to any gap scatter of the reproduce head.

The situation is further complicated by the fact that no recordings are perfect, thus dynamic skew produced by the record process will introduce greater time displacements on replay.

In the MODAS system the multi-track serial data recording format, Fig 8, with track synchronisation words inserted between groups of data words enables a de-skewing operation to be carried out in the recovery electronics on replay, so the above sources of error are minimised.

2.3.2 Contamination

The most common source of errors, certainly as far as the user is concerned, is the build-up of contamination on the headstacks. It takes the form of oxide and other debris picked up from the tape as it passes over the head and can cause head-to-tape separation and the associated degradation of either the recorded signal or reproduce output, the latter in accordance with the Wallace formula. Fig 9 indicates some typical sizes of contamination particles in relation to the head and tape dimensions.

The tape path components (capstan, guide rollers, headstacks, etc) can be cleaned using a proprietary cleaner which can be in the form of a lint free pad soaked in isopropyl alcohol. It is important that this is done frequently, as in some environments cleanliness cannot be assured and in any case oxide and other debris from tape will be collected over a period of time. It is good practice to clean the tape path components before each recording is made.

2.3.3 Head wear

(a) Normal head wear

The heads normally used in MODAS record and replay systems are designed to last for approximately 1000 hours of operation under the normal conditions

of tape tension and wrap angle. This holds true for the ground replay system. On the HERs the tape tension and wrap angle are increased to reduce the likelihood of tape separation under the high 'g' forces experienced in high performance aircraft, but since the tape is driven at lower speeds than the replay machines the head life will be similar.

(b) Gap distortion or 'smear'

This phenomenon occurs when the smooth surface of the tape causes molecular adhesion to the head surface. Core lamination material flows across the gap and short circuits it magnetically. The smear can be removed by using a lapping tape, followed by polishing along the line of the gap. (This requires specialist materials and should not be attempted by the user.)

2.3.4 Magnetisation

It is possible for the heads (both record and reproduce) to become magnetised.

Any magnetisation of the record heads will produce unwanted dc bias which will result in a distorted recorded waveform. This distortion may give rise to an increase in decode errors on replay owing to time displacement from their ideal positions of the transitions through zero.

Magnetisation of the reproduce head could attenuate or completely swamp the replay signal.

2.4 Tape problems

2.4.1 Contamination

Any contamination being present on the oxide surface will cause head-to-tape separation as mentioned earlier. The effect is to produce 'dropouts' or discontinuities in the recording.

To reduce the possibility of errors produced by contamination the tapes can be cleaned by passing them through a tape cleaner.

The tape is loaded onto a machine similar in design to that of a replay deck. The tape passes over tissue pads or rollers which contact and wipe both surfaces thus removing loose contamination from the tape.

2.4.2 Tape erasure

The MODAS tape recorders do not have erase heads built in. Therefore should it be necessary to re-use a reel of tape, it is essential that the

previous recording is completely erased. This can be done by using a bulk eraser, which will generate a strong alternating magnetic field. The reel of tape is placed in the magnetic field and then slowly removed. Thus the field effectively decays leaving the tape unmagnetised. The eraser must produce a magnetic field of at least 1000 Oersteds to effectively erase the tape of the type currently used. It is good practice to erase all new tape. Manufacturers do occasionally leave high level test signals recorded on samples.

2.4.3 Tape handling

MODAS recorders, especially the HER 400 and 600 range, have their reels loaded from a bulk source, usually 10.5 inch diameter reels of tape, and tape winders are provided for that purpose. Care is needed at the start of a wind to avoid creasing the tape by incorrect location on the guide rollers or tape reel. Creasing of the tape can produce head-to-tape separation.

It is advisable to inspect the reels for trueness before loading as bent or damaged reel flanges can cause edge damage to the tape and introduce low frequency flutter when recording.

It is good practice when loading the tape into the recorder to wind a few feet of tape on to the take-up spool to clear any possible area of damage.

It is NOT permissible to attach the ends of the tape to the reel hubs with adhesive tape of any kind or to use adhesive tape to secure the outer loose end. This will cause contamination of the headstack and/or guide rollers, and may even adhere to the capstan producing a tape roll resulting in mechanical damage.

One instance where extreme care is required is when tapes are being prepared for use with track-switching recorders. Transparent windows have to be present at each end of the tape and these are made by removing the oxide and anti-static black back coating leaving a clear base film. The current method is to lay the tape on a flat clean surface and place a metal mask over the area where the window is required. The coating exposed by the mask is then removed by dissolving the binder with methyl ethyl ketone solvent (MEK)*.

Obviously, significant handling of the tape is necessary during coating removal and of course when the tape is used data will be recorded up to the window edge. Therefore a large increase in dropout errors is inevitable. Great care must be taken to minimise this effect but any visible damage, however small,

* MEK is a highly inflammable solvent. It should only be used in accordance with the manufacturer's safety instructions.

will produce a large dropout error. Transparent leaders or reflective markers cannot be used in an airborne environment as any, even thin splicing material, will result in the joint being impressed through many layers of tape introducing large numbers of burst errors.

2.4.4 Tape storage

Ideally, the environment for the storage of magnetic tape in a dust-free atmosphere maintained at a temperature of between 15°C and 25°C and a relative humidity of 10% to 20%. Although the above conditions are recommended for long term storage it can be seen from Fig 10, a chart showing the zones of acceptable, marginal, and unacceptable storage conditions, that the temperature and humidity ranges for acceptable storage, zone 1, are quite large. Normal laboratory conditions will probably suffice provided that care is taken to ensure that the tapes are protected from dust and other contamination, also that they are not left near hot radiators or in direct sunlight. The reels of tape should always be stored with the flanges vertical.

Tape exposed to the extremes of temperature and humidity covered by zone 3 of Fig 10 for any length of time may suffer from the breakdown of the polymeric polyester urethane oxide binder. This breakdown may give rise to tape problems such as layer-to-layer adhesion, tape squeal, increased tape drag and friction, and liberation of gummy and sticky head deposits.

The above figures and information for the chart are taken from an Appendix to a BSI document on magnetic tape storage to be published shortly.

It is also recommended that reels of tape should be re-spooled periodically to relieve any internal stresses in the tape stack which may have built up during storage due to variations in ambient temperature. This is especially important for archival tapes required to be stored for long periods.

3 CHOICE OF PCM CODES

3.1 General

Two important features of the pcm codes used in the MODAS system are that:

(a) they are essentially dc free, since dc cannot be reproduced from magnetic tape because there is no change in flux and hence no induced voltage on replay, and

(b) they are self-clocking thus avoiding the need to record a separate clock track on the tape in order to recover the data.

The inclusion of clock tracks would reduce the number of tracks available for the recording of data.

The packing densities chosen for MODAS operations are very conservative when compared with manufacturers claims for performance, but recording conditions for airborne trials are far from ideal. It is very difficult to avoid tape contamination. Most systems certainly do not operate in dust free conditions any many recording systems have to be matched to a common replay system. Most manufacturers' claims for very high packing densities are for machines operating in laboratory conditions, the tapes usually being recorded and reproduced on the same machine.

3.2 Bi-phase code

This code, also known as the Double Frequency or Manchester code, is shown in Fig 1'a. The self-clocking feature of this code is achieved by inserting transitions at the clock rate. Two transitions are produced whenever a "1" is recorded. This is, of course, the double frequency and each "1" can be considered to be twice the clock frequency and a "0" to equal the clock frequency. The disadvantage is that double the bandwidth is required to generate this code, and as far as MODAS is concerned this limits the packing density on the tape to 10 kbp.

Bi-phase code is a very secure code with high tolerance for jitter and timing errors.

3.3 Miller-squared code

Miller-squared code is an evolution of the Miller code⁶ designed to remove the latter's asymmetry which results in dc shifts being produced when certain data patterns are encoded. The data are divided into four sequences. These are: a single "1", a pair of "0"s, a single "0" followed by an odd number of "1"s, and a single "0" followed by an even number of "1"s. All these bit patterns are symmetrical, except the last one, and this is modified to make it symmetrical by omitting the transition pertaining to the last "1". An example of M^2 code is shown in Fig 1'b.

Miller-squared code needs a higher signal-to-noise ratio than Bi-phase so the basic error rate will be greater for any given machine. Miller-squared should be reserved for long duration requirements. The packing density for MODAS application using Miller-squared is normally restricted to 20 kbp.

4 EQUALISATION OF THE REPRODUCE AMPLIFIERS

4.1 Need for equalisation

Fig 12 illustrates a typical record/reproduce response with frequency. It assumes that the recording head current is maintained at constant level for all frequencies. The tape magnetisation decreases at high frequencies and the resultant response is shown in Fig 12a.

The voltage induced in the reproduce head is proportional to the tape magnetisation and also its frequency. This tends to compensate for the decreasing magnetisation at the higher frequencies as shown in the voltage versus frequency curve, Fig 12b.

In order to achieve a constant output voltage over the entire frequency range, more amplification must be provided at the low and high frequencies. This is known as equalisation and its characteristic is shown in Fig 12c. The disadvantage of this amplification is that noise inherent in the system is also boosted at low and high frequencies, further restricting the useful range.

4.2 Optimisation of record current

When recording, there is an optimum record head current to produce the maximum reproduce head output for a given packing density. Fig 13 shows the relationship between head current and output. Heads driven above the optimum value suffer a loss of bandwidth due to an effect known as pulse crowding. In practice the head currents are adjusted by the selection on test of series resistors, one for each track, which are incorporated into the machine prior to it being issued to the user. This is not a user adjustment.

5 SOME METHODS FOR OPTIMISING THE EQUALISATION OF REPRODUCE AMPLIFIERS

5.1 Eye patterns

Although pcm recording is the process of transferring digital data to magnetic tape, the recorded signals are analogue. If the output of a reproduce amplifier is observed on an oscilloscope, waveforms of a near sinusoidal nature will be displayed. The waveforms which should be symmetrical about zero volts are known as 'eye patterns'. In a good recording with correct equalisation of the reproduce amplifiers, Fig 14a, the transitions through zero, termed zero crossings, should appear to be coincident, and the 'eyes' will appear large. This will result in good recovery of the recorded data with low error rates. Poor equalisation, Fig 14b, will result in the zero crossings being somewhat

spread and the 'eyes' will appear to be rather closed. The maximum allowable tolerance for the spread of the transitions is $\pm \frac{1}{2}$ bit period of the ideal position. Any transitions falling outside these limits will cause a recovery error and loss of data.

This observation technique is a convenient and fairly easy way to adjust and optimise the equalisation of the reproduce amplifiers of the MODAS replay tape transports for low error rates.

Using a known good recording the output level, phase equalisation, and amplitude equalisation adjustments can be made to minimise error rates on replay. The phase adjustment can be made in both the forward and reverse directions. The amplitude equalisation circuits are speed sensitive and therefore an adjustment is provided for each of the available tape speeds.

The method is to select a tape speed of say $7\frac{1}{2}$ ips, which is mid-range for MODAS replay, and at this speed and in the forward direction set the gain of the amplifier under adjustment to produce an output of about 1 volt rms measured at the test point provided on the printed circuit board. The phase control for the forward direction is then adjusted in conjunction with the appropriate band edge amplitude potentiometer to produce the best waveshape and zero crossing. The process is then repeated in the reverse direction using the reverse phase control only. The phase adjustment potentiometers are then left alone and at each other tape speed selected the band edge amplitude control is adjusted for best results. Fig 15 shows an example of good equalisation for both Bi- ϕ and M^2 recordings.

5.2 Transition distribution analysis

The timing periods for the zero crossings are well defined and for a perfect recording and perfect equalisation on replay the transitions will occur exactly at those times. In practice the transitions will vary from their ideal position owing to system imperfections such as jitter, peak shifting, noise and tape imperfections. The 'eye patterns' indicate the more frequent transitions quite easily but it is much more difficult to observe the less frequent combinations on an oscilloscope, especially for M^2 .

A more sophisticated technique has now been adopted using a Kode Time Interval Analyser type TIA-2001. This instrument takes the place of the oscilloscope as the monitor of the reproduce amplifier's output and uses statistical methods to indicate the equalisation performance of the amplifier. The TIA-2001 is programmable and can be set up to count and measure the time distribution of

a large number of transitions, up to 10^9 but 10^5 is usually good enough to determine the performance, and display the result in histogram form on a small integral display.

In the scan mode the display indicates in histograms the distribution of all the transitions taken in the sample. If the TIA-2001 is set to monitor and count from one zero crossing to the next in either direction, there will be two transition groups for $Bi-\phi$ occurring at 0.5 and 1 bit cell times, and five transition groups for M^2 occurring at 1, 1.5, 2, 2.5 and 3 bit cell times. Typical examples of the transition groups as displayed for both $Bi-\phi$ and M^2 are shown in Fig 16a&b. The time between transition groups will depend on the selected tape replay speed.

A segment mode can be used to set boundaries around the expected transition position. These boundaries or segments are time slots centred on the ideal zero crossing times. The widths of the segments are adjustable and for the pcm codes used are set to $\pm\frac{1}{4}$ bit period, any transition falling within these limits will count as good. The segments appear as lines along the time axis beneath the histograms (see Fig 18).

Each tape replay speed will require unique segment and timebase data settings on the TIA-2001 and it is possible to store up to eight sets of data in memory in the form of programs. Fig 17 shows the segment menu set up for M^2 recordings to be replayed at $7\frac{1}{2}$ ips. The mean values of each segment corresponding to the ideal transition times are entered in nanoseconds and the half-segment value is set to a $\frac{1}{4}$ bit period.

The memory has battery backup power so the information stored is not lost when the mains power is switched off. The program can be loaded into the working store by simply selecting the appropriate program number and pressing the program button.

An example of the segment mode display for a M^2 recording is shown in Fig 18. The selected timebase allowed only the first three transition histograms out of five to be displayed. The two vertical cursors mark the ideal zero crossing times for the first two groups. The segments are displayed underneath the histograms, a solid line indicating the first position and dotted lines the subsequent ones. The time-base selected for the display makes the lines appear continuous, but in fact there are gaps in time of 100 nanoseconds between segments.

The instrument can perform arithmetic on the segment data and display a summation graph, an example of which is shown in Fig 19a. The leading and trailing edge margins, the time difference between the segment boundaries and the intersection of the histogram on the time axis, are measured and can be displayed in nanoseconds. The shape of the histogram gives a good indication of the performance of the equaliser and/or the state of the recording. The ideal shape is a single vertical line at the centre of the segment, but in practice a symmetrical form with narrow skirts is a good compromise. This is the best display to use when adjusting the equalisation.

Another useful display, shown in Fig 19b, which can be used to determine the bit error rate is based on the data shown in Fig 19a. It indicates the probability density of the data. Pattern sensitivities show up as a flattening of the curve at the top while the signal to noise ratio affects the slope. The intrinsic bit error rate of the amplifier is revealed at the point of intersection with the segment boundary. To achieve an accurate assessment the data can be accessed, fed via an IEEE bus to a computer, and curve fitting applied using a suitable computer programme.

The adjustment procedure for the amplifier is the same as for the eye pattern method but the TIA-2001 provides a much more accurate picture of the equalisation performance.

6 CONCLUSIONS

This Memorandum has given some background information on the magnetic tape recording process used in MODAS and advice to users on good tape management. Design considerations and problems concerning the head/tape interface have been highlighted and reasons for the choice of pcm codes given. It has been emphasized that the user must be very careful when handling magnetic tape in order to reduce error sources to a minimum. Finally some insight into the equalisation performance and setting up procedure of the reproduce amplifiers has been provided.

All this is in the present! As for the future there are helical scan recorders on the market which have potential for use as MODAS airborne data recorders because of their small size, large data capacity and long recording duration. Also the use of associated magnetic tape cassettes simplifies machine loading and greatly reduces the possibility of tape damage. However, development work will be needed to improve their capability to operate in a harsh environment and to integrate them into the existing MODAS system.

AppendixCONVERSION FACTORS

Traditionally, the units used for dimensions and tape speeds in the realm of magnetic tape recording are imperial, and the text of this Memorandum reflects this. However, in order to comply with the use of metric units the following tables of conversion factors have been drawn up:

Head gap sizes

record	85 μ inch	-	2.16 μ m
replay	25 μ inch	-	0.63 μ m

Tape sizes

width	1 inch	-	25.4 mm
thickness	1240 μ inch	-	31.5 μ m

Record/replay tape speeds

15/16 ips	-	23.8 mm/s
1 $\frac{7}{8}$ ips	-	47.6 mm/s
3 $\frac{3}{4}$ ips	-	95.2 mm/s
7 $\frac{1}{2}$ ips	-	190.5 mm/s
15 ips	-	381.0 mm/s
30 ips	-	762.0 mm/s
60 ips	-	1524.0 mm/s
120 ips	-	3048.0 mm/s

HER capacities

700 ft	-	213 m
1500 ft	-	457 m
2400 ft	-	731 m

Packing density

10 kbit/inch	-	400 bit/mm approximately
20 kbit/inch	-	800 bit/mm approximately

Magnetic field strength

1000 oersted	-	$\frac{10^6}{4\pi}$ A/m
--------------	---	-------------------------

REFERENCES

<u>No.</u>	<u>Author</u>	<u>Title, etc</u>
1	G.R. Labrum D.C. Alexander C.W. Jackson	The design of a high packing density pcm magnetic tape replay system. RAE Technical Report 77140 (1977)
2	G.R. Labrum D.C. Alexander C.W. Jackson	The design of a high packing density pcm magnetic tape replay system. RAE Technical Report 77140 (1977)
3	Inter-range Instrumentation Group	IRIG Document 106-85. Secretariat, Range Commanders Council, White Sands Missile Range, New Mexico, USA (1985)
4	W.K. Westmijze	Studies on magnetic recording. Phillips Research Reports, Vol 8, pp 161-183, pp 245-269 June 1953
5	R.L. Wallace	Reproduction of magnetically recorded signals. Bell System Tech. Jour., pp 1145-1173, October 1951
6	David A. Schuldt	A discussion on pcm recording with emphasis on the Miller code. Applications Engineering - Ampex Instrumentation Division

Fig 1

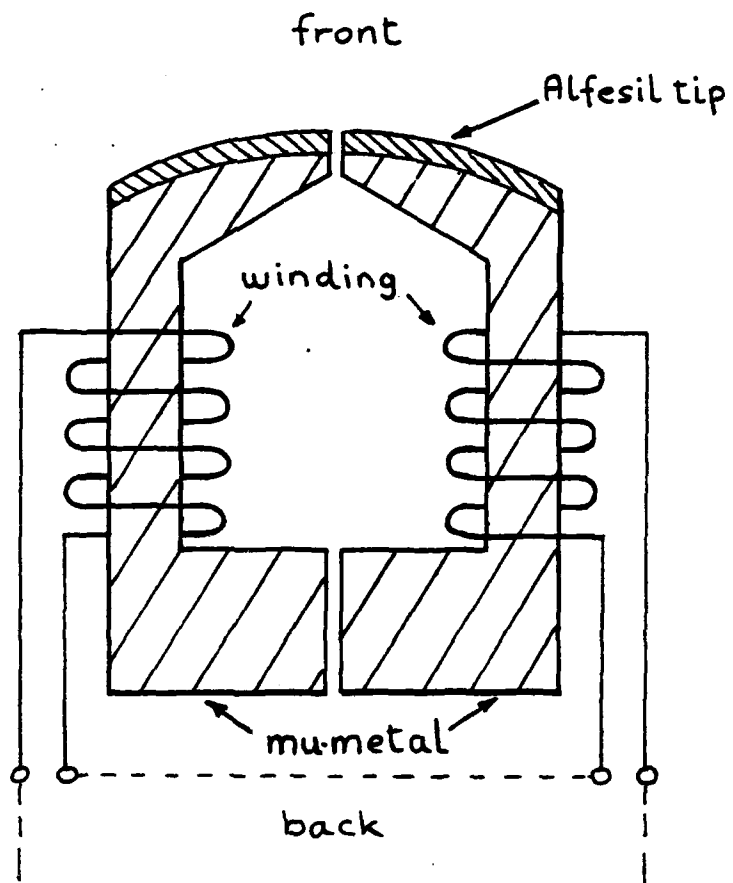

Fig 1 A typical core structure

TM IT 212

Fig 2

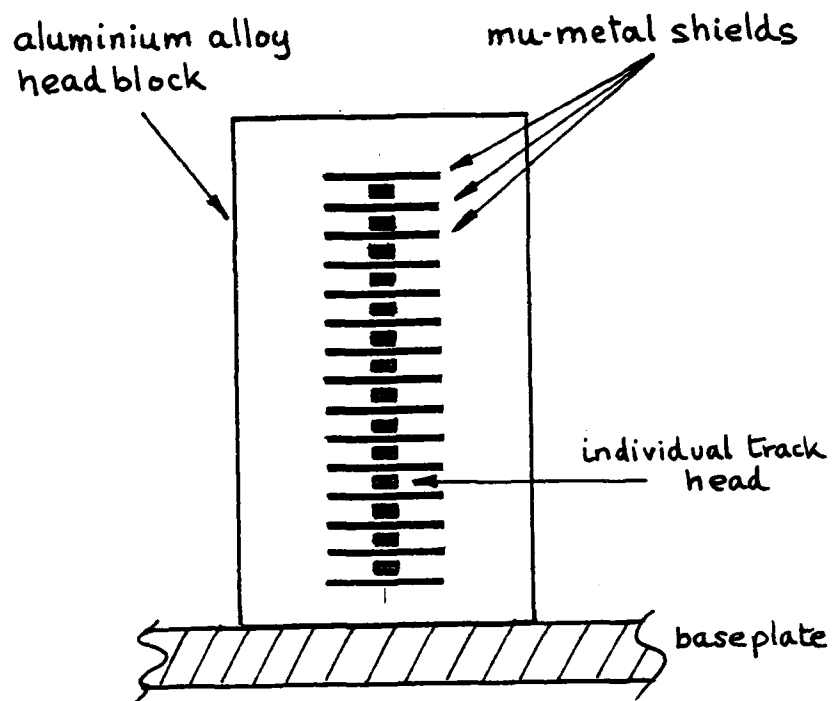
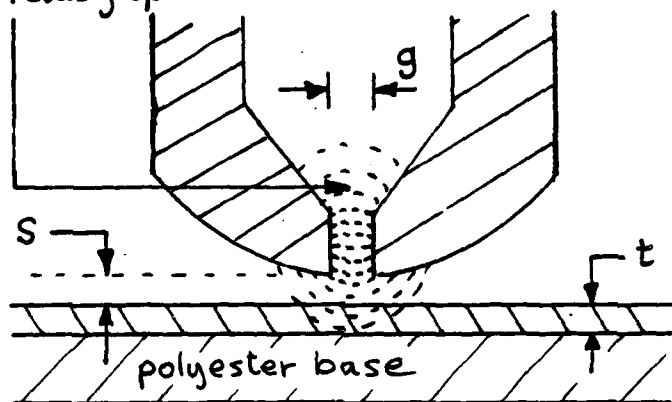

Fig 2 A 14-track headstack

Fig 3

fringing magnetic field
at head gap



g = gap length

S = head to surface spacing

t = thickness of recording layer

Fig 3 Head/tape relationship

Fig 4

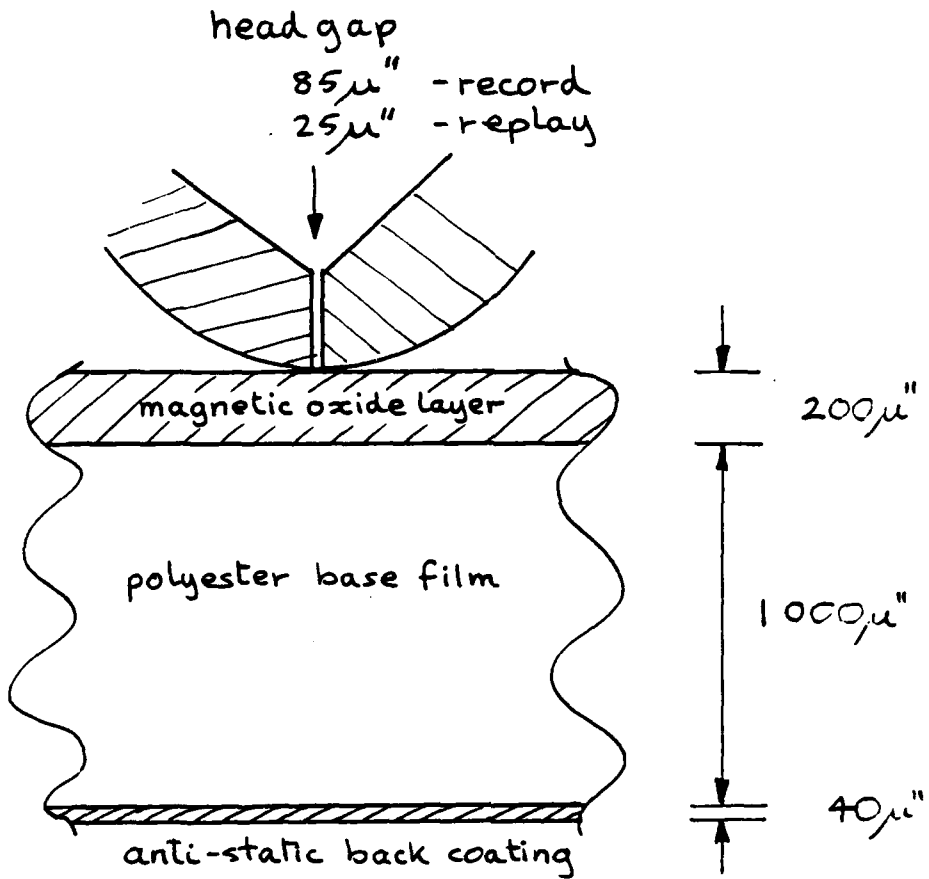
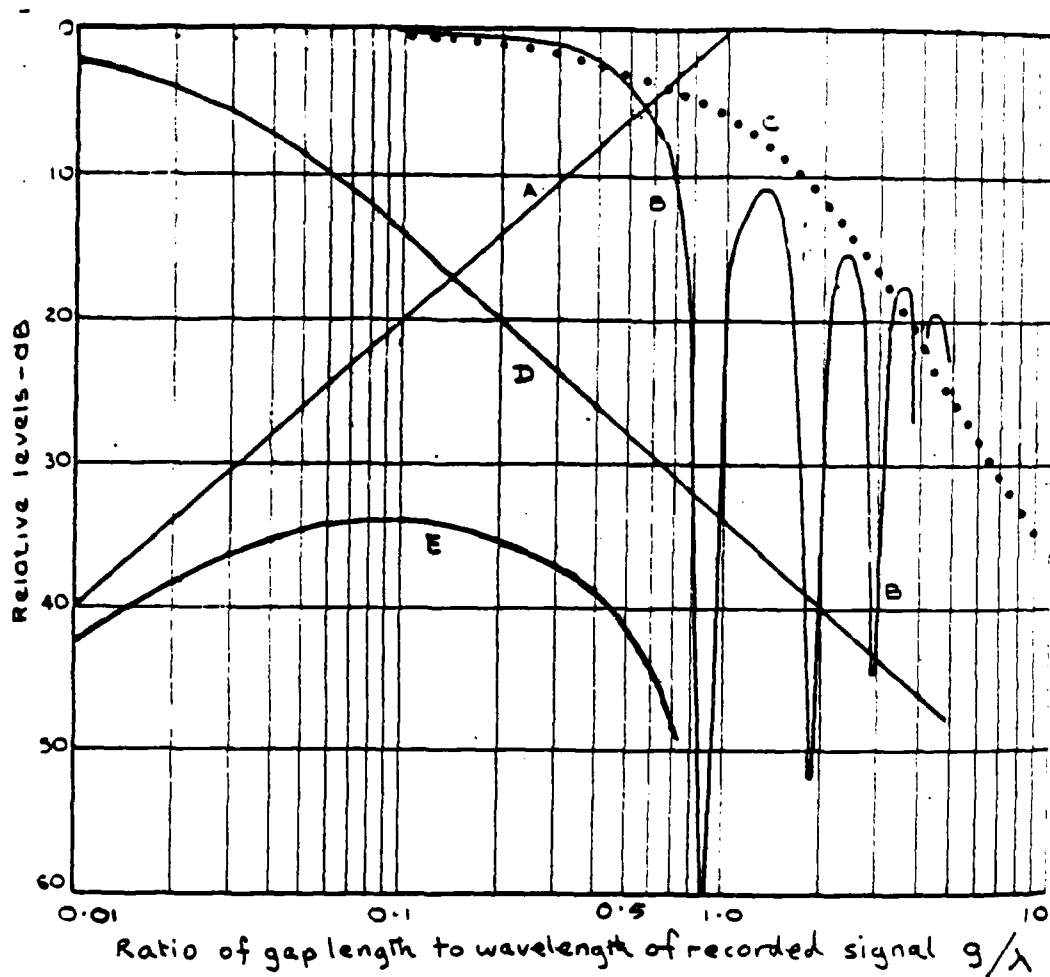

Fig 4 Typical head gap and tape dimensions

Fig 5



- A. Ideal response
- B. Gap loss
- C. Separation loss (for separation $S = 0.1g$)
- D. Thickness loss (for thickness $t = 8g$)
- E. Overall response

TM IT 212

Fig 5 Frequency characteristic for reproduce head

Fig 6

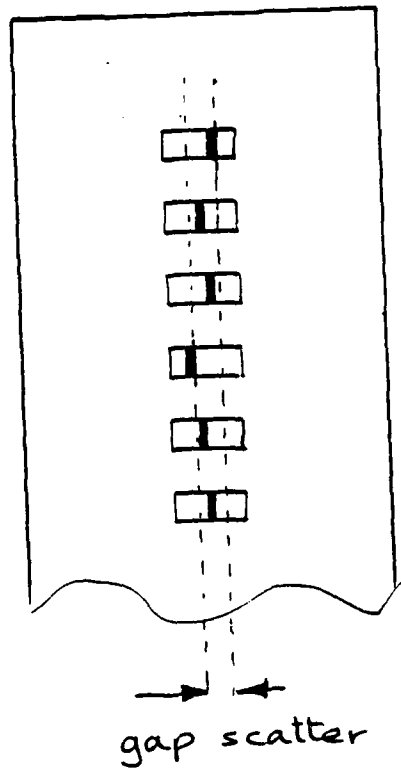

Fig 6 Gap scatter

Fig 7

Head azimuth line passes through the mean of the gap centres on all tracks

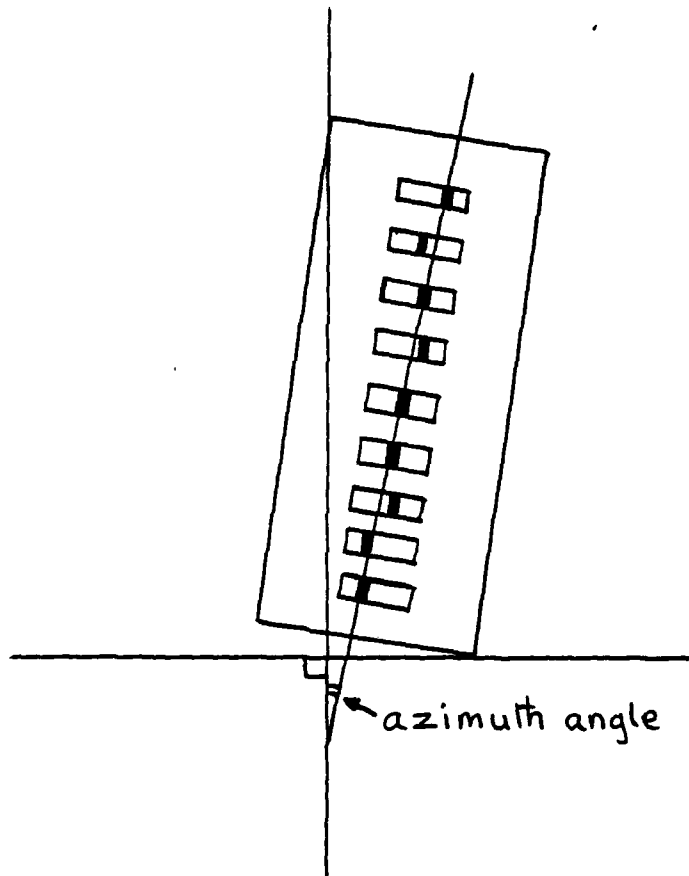

Fig 7 Head azimuth

Fig 8

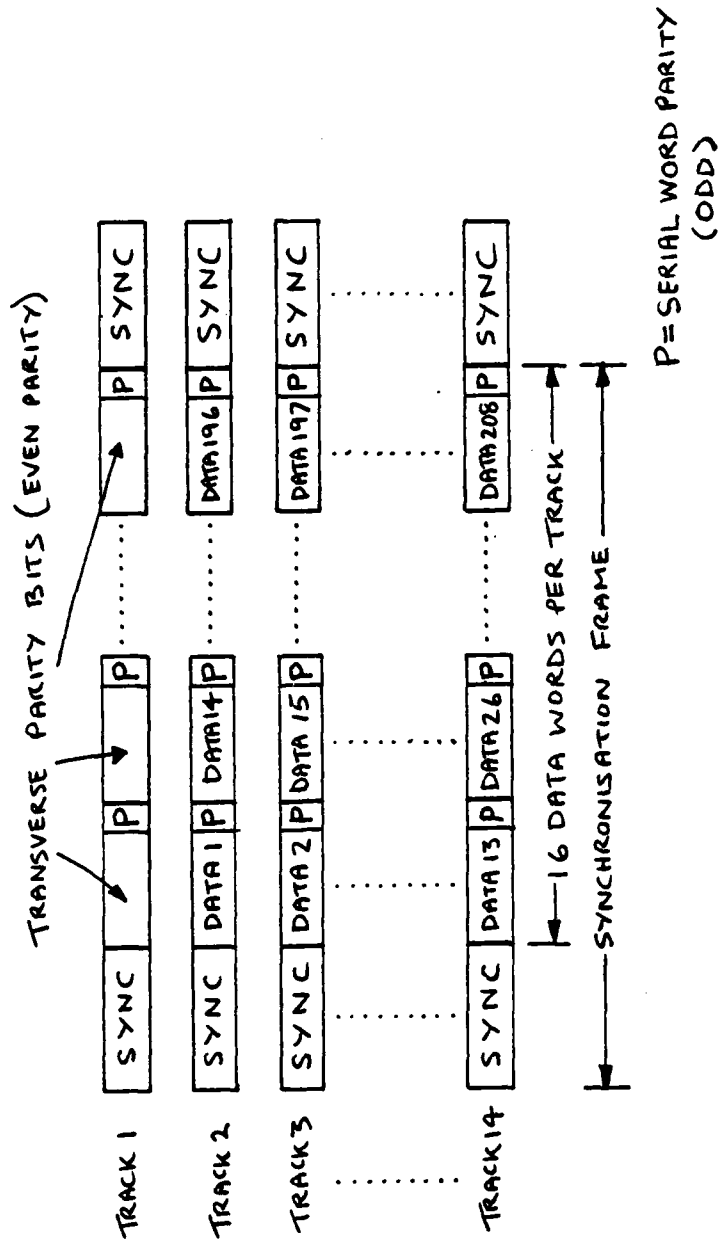

Fig 8 Multitrack serial data record format for MODAS

Fig 9

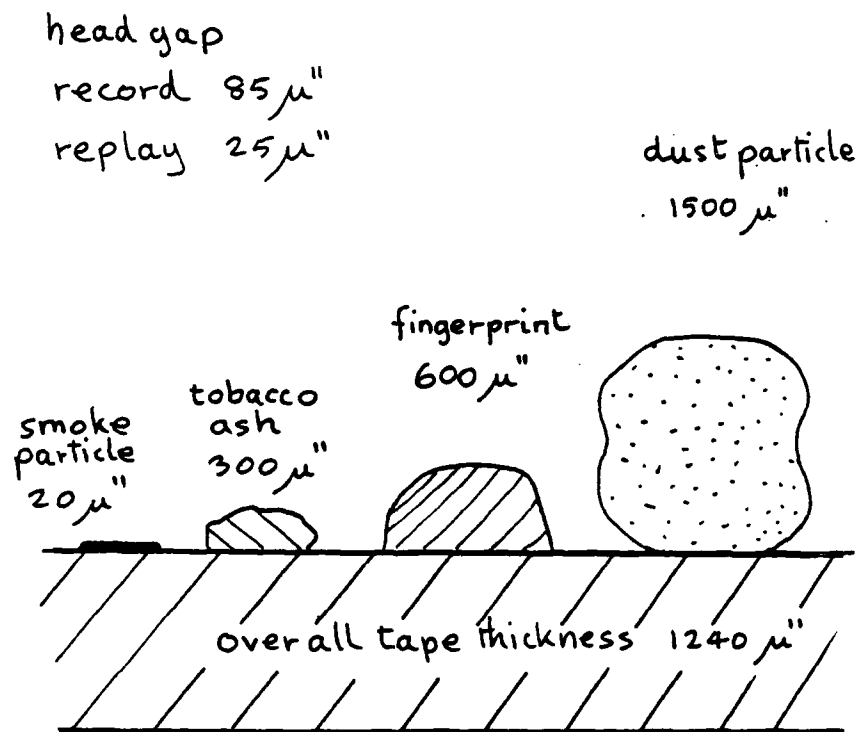

Fig 9 Typical sizes of contamination particles

Fig 10

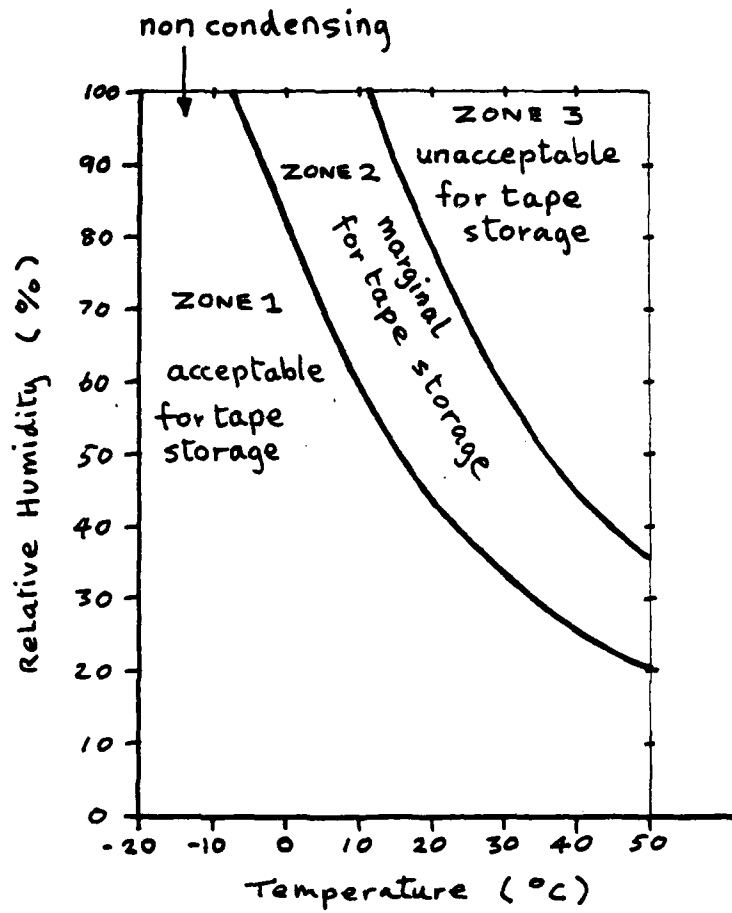

Fig 10 Magnetic tape storage environment

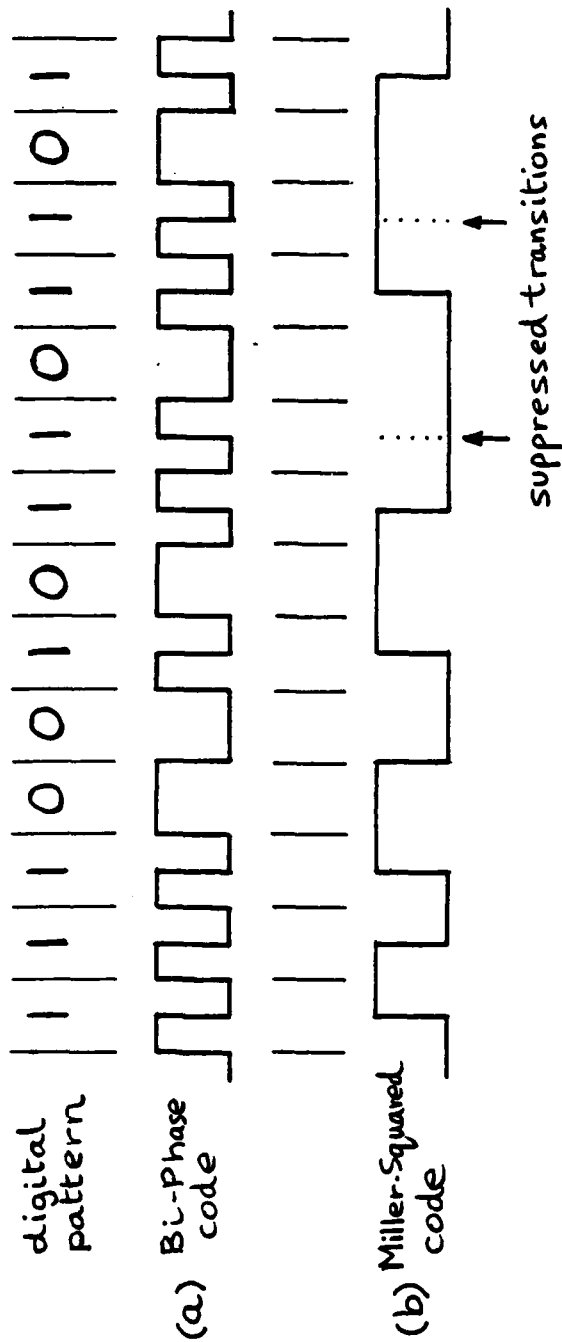

Fig 11

Fig 11 Examples of the pcm codes used by MODAS

Fig 12

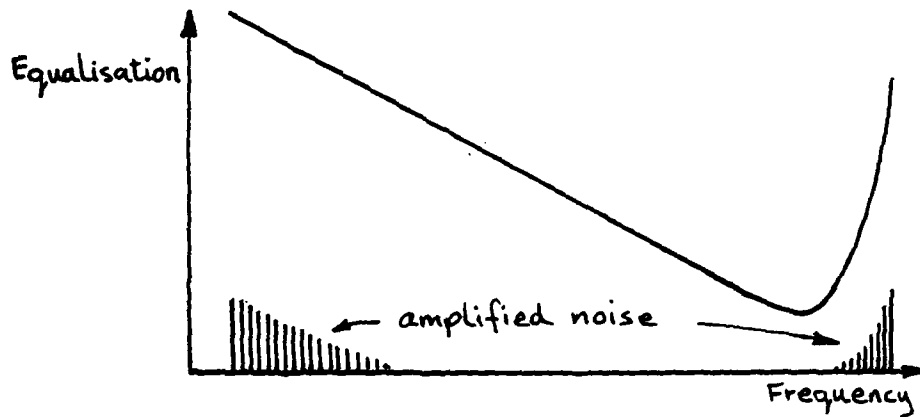
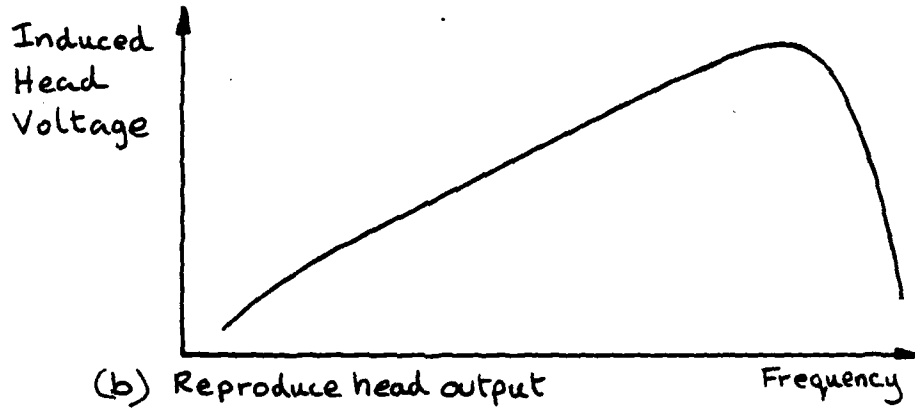
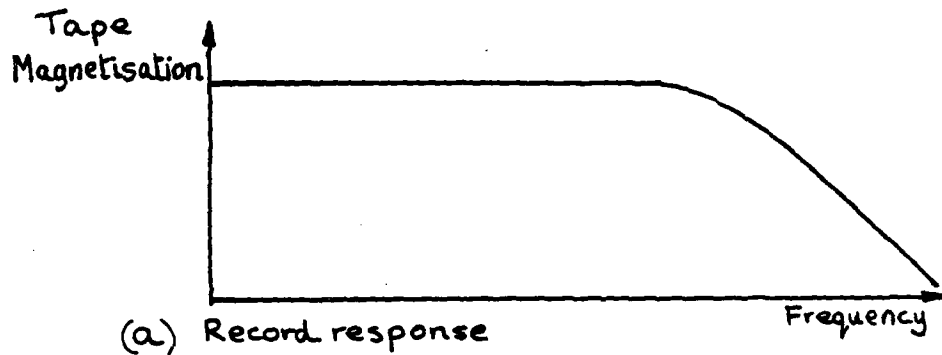

Fig 12 Typical record/replay response

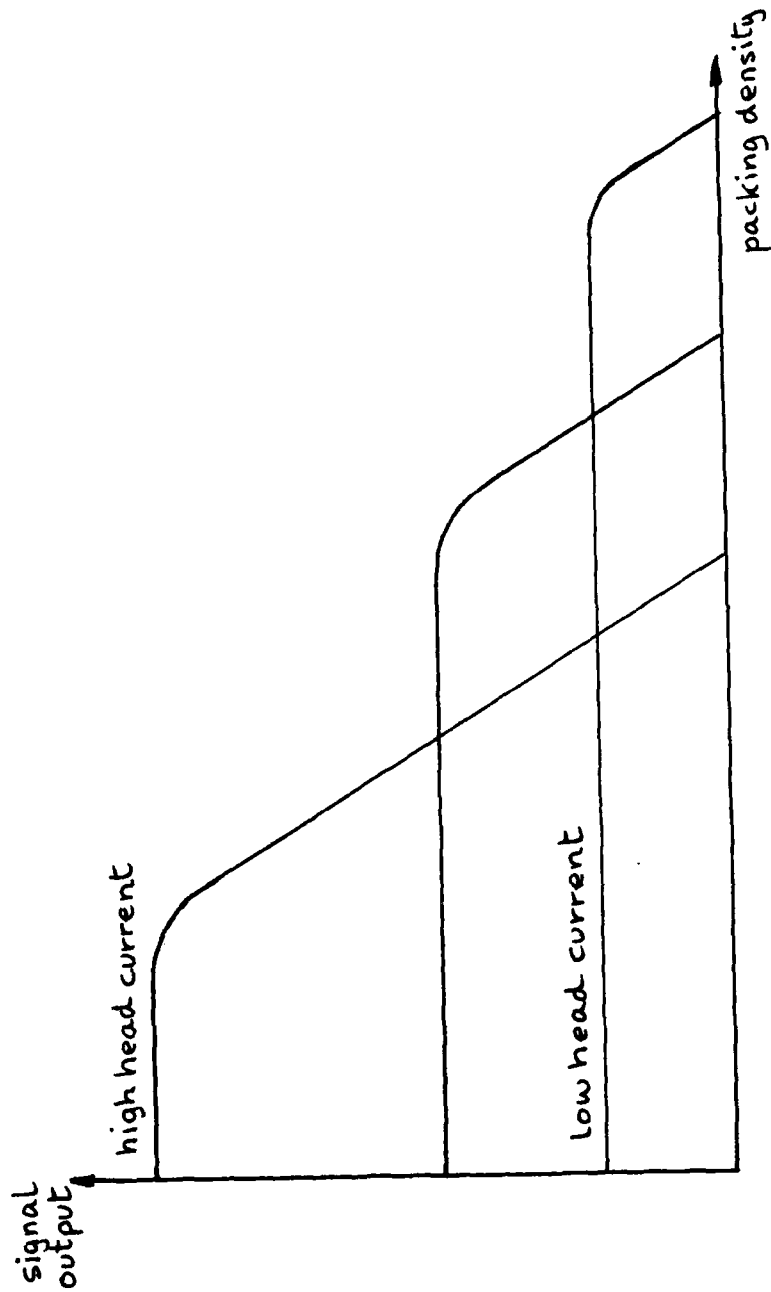
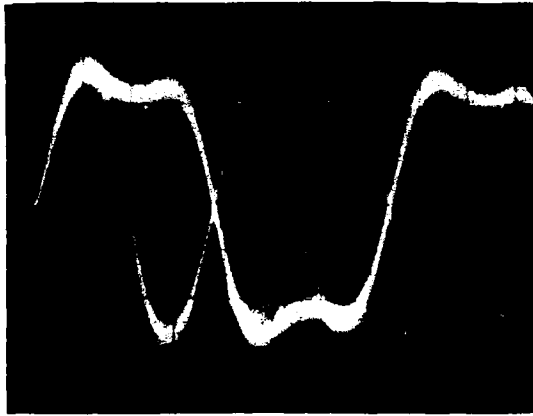

Fig 13

Fig 13 Relationship between head current and signal output

Fig 14



(a) Good 'eyes' - correct equalisation

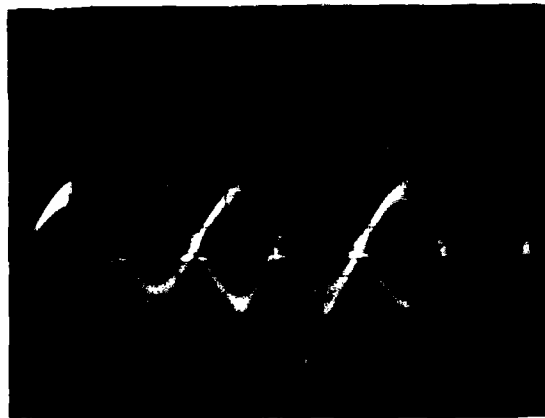

(b) Poor 'eyes' - incorrect equalisation

Fig 14 Eye patterns

Fig 15

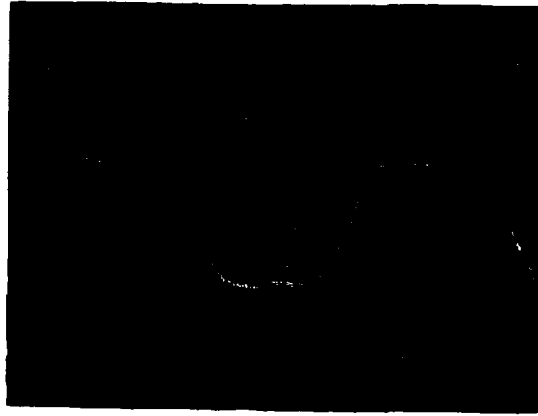

(a) Bi-phase

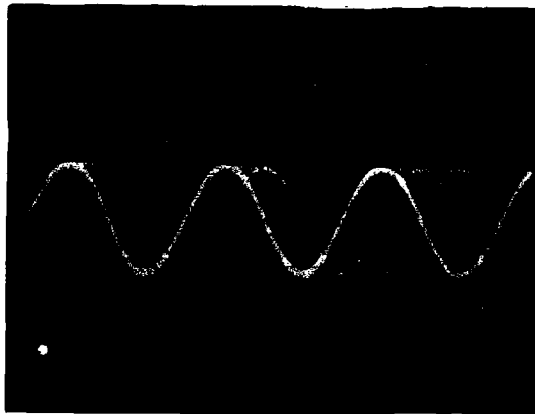

(b) Miller-squared

Fig 15 Examples of good equalisation

Fig 16

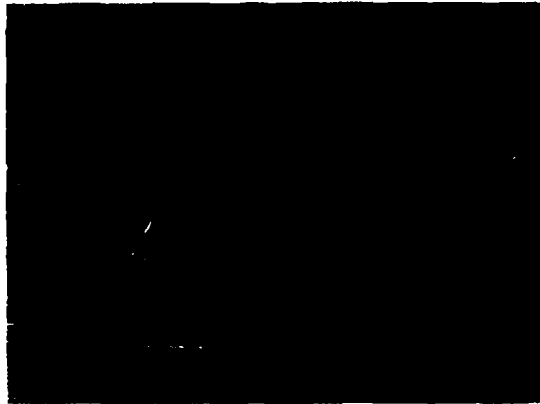

(a) Bi-phase

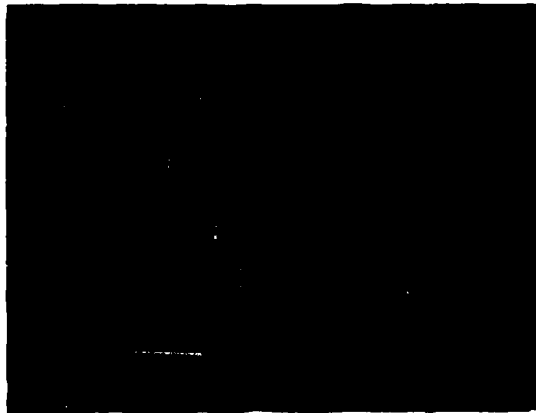

(b) Miller-squared

Fig 16 TIA-2001 - view mode display

Fig 17

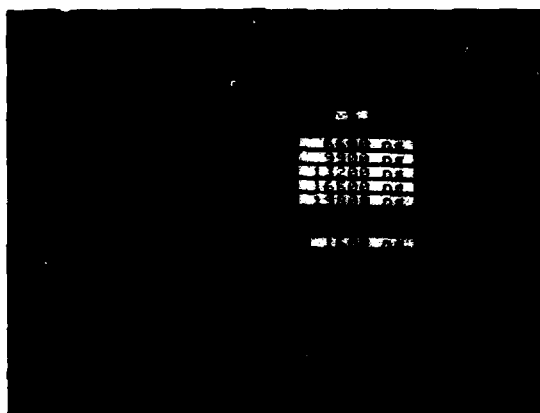

Segments set up for M² recording to be
replayed at 7½ ips

TM IT 212

Fig 17 TIA-2001 - segment menu display

Fig 18

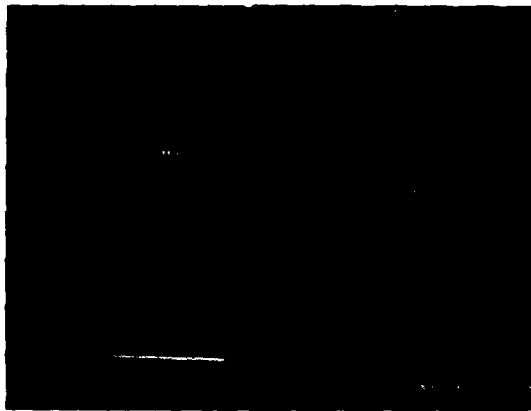
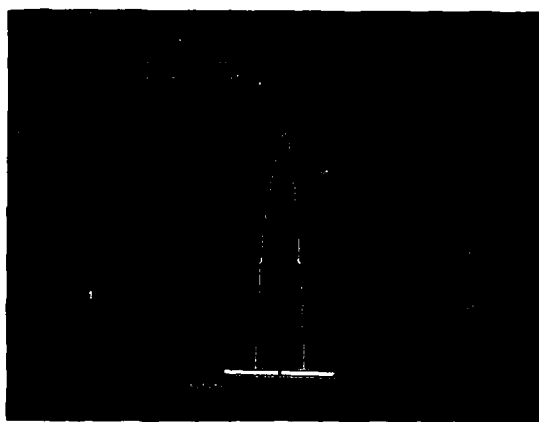
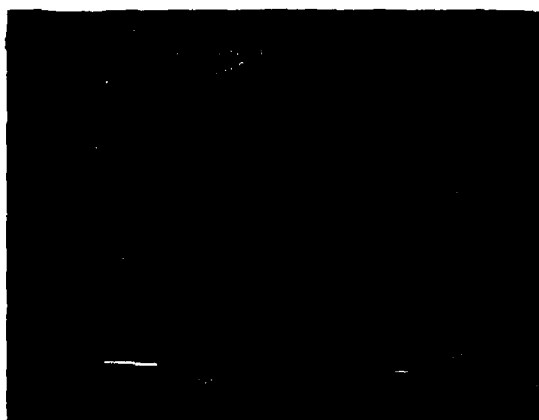

Fig 18 TIA-2001 - segment mode display

Fig 19



(a) Summation histogram



(b) Bit error rate determination curve

Fig 19 TIA-2001 - segment summation and bit error rate displays

