

UNLIMITED DISTRIBUTION



National Defence
Research and
Development Branch

Défense nationale
Bureau de recherche
et développement

TECHNICAL MEMORANDUM 88/202
February 1988

AD-A196 220

ERROR BOUNDS ON ESTIMATED AZIMUTHAL
AND VERTICAL ARRIVAL ANGLES AT
A ROTATABLE HORIZONTAL LINE ARRAY

James A. Theriault

DTIC
ELECTE
JUN 22 1988
H

Defence
Research
Establishment
Atlantic



Centre de
Recherches pour la
Défense
Atlantique

Canada

DISTRIBUTION STATEMENT A
Approved for public release
Distribution Unlimited

UNLIMITED DISTRIBUTION



National Defence
Research and
Development Branch

Défense nationale
Bureau de recherche
et développement

ERROR BOUNDS ON ESTIMATED AZIMUTHAL
AND VERTICAL ARRIVAL ANGLES AT
A ROTATABLE HORIZONTAL LINE ARRAY

James A. Theriault

February 1988

Approved by R.F. Brown Director/Underwater Acoustics Division

DISTRIBUTION APPROVED BY

D/UAD

TECHNICAL MEMORANDUM 88/202

Defence
Research
Establishment
Atlantic



Centre de
Recherches pour la
Défense
Atlantique

Canada

Abstract

A Horizontal Line Array (HLA) is subject to left-right bearing ambiguity and also to bearing bias caused by non-zero vertical arrival angles. However, if a second observation is made with the array rotated to a different orientation, the azimuthal and vertical arrival angles may be estimated. For two observations where the source-array geometries are static, a closed-form solution is available. For the solution error, a closed-form approximation is also available, but only if the observation errors are small. This report deals with the case of moderate to large observation errors and presents error bounds on the estimated azimuthal and vertical arrival angles. As well, several examples are included.

Sommaire

Un réseau linéaire horizontal (HLA) peut comporter une ambiguïté vers la gauche ou la droite ainsi qu'un biais de gisement en raison des angles d'arrivée verticaux non nuls. Toutefois, si on effectue une seconde observation après avoir amené le réseau à une autre orientation, on peut estimer les angles d'arrivée azimutaux et verticaux. Si l'on dispose de deux observations dans lesquelles la géométrie source-réseau est statique, on peut obtenir une solution de forme close. On peut aussi obtenir une solution de forme close pour la fonction d'erreur de la solution, mais seulement si les erreurs d'observation sont d'un très faible niveau. Le rapport traite des cas d'erreurs d'observation de niveaux moyens à très élevés et présente les limites d'erreur sur les angles d'arrivée azimutaux et verticaux estimés. Il contient aussi plusieurs exemples.

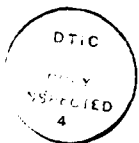

Accession For	
NTIS GRA&I	<input checked="" type="checkbox"/>
DTIC TAB	<input type="checkbox"/>
Unannounced	<input type="checkbox"/>
Justification	
By	
Distribution	
Availability Codes	
Avail and/or	
Dist	Special
A-1	

Contents

Abstract	ii
Table of Contents	iii
List of Figures	v
1 Introduction	1
2 The HLA Bearing Bias Problem	2
3 Estimation of Azimuthal and Vertical Angles	4
3.1 Method of Solution	4
3.2 Assumptions and Restrictions	4
3.3 The Analytic Model	4
3.4 Analytic Solution	5
4 Extrema of Error Intervals	6
4.1 Method of Solution and Definitions	6
4.2 Local Minima and Maxima of The Vertical Arrival Angle	8
4.2.1 Local Minima and Maxima in the Interior of the Domain	8
4.2.2 Local Minima and Maxima on the Boundary of the Domain	9
4.3 Local Minima and Maxima of Azimuthal Arrival Angle	10
4.3.1 Local Minima and Maxima in the Interior of the Domain	11
4.3.2 Local Minima and Maxima on the Boundary of the Domain	11
4.4 Summary on Error Bounds for ϕ and θ	12
5 Graphic Example	13
5.1 Errors in Observed Data	13
5.1.1 Errors in Observed Signal Arrival Angles	13
5.1.2 Errors in Rotation Angle	14

5.2	Definitions of Bounds on Various Parameters	14
5.3	Results for Small Observation Errors	14
5.4	Results for Moderate Observation Errors	18
6	Conclusion	21
	Bibliography	22
	Appendix	23
A	Parametric Analysis of Maximum Azimuthal and Vertical Arrival Angle Errors for Small Observation Errors.	23

List of Figures

2.1	Arrival Angle Geometry	2
2.2	HLA Bearing Bias as a function of azimuthal angle θ , for several values of vertical arrival angle ϕ	3
5.1	Maximum absolute error in computed azimuthal angles for $\Delta\theta = 20^\circ$, $\sigma_0 = 1^\circ$, and $h = 0^\circ$	15
5.2	Error bounds on computed vertical angles for $\Delta\theta = 20^\circ$, $\sigma_0 = 1^\circ$, and $h = 0^\circ$	16
5.3	Maximum absolute error in computed azimuthal angles for $\Delta\theta = 20^\circ$, $\sigma_0 = 0^\circ$, and $h = 1^\circ$	16
5.4	Error bounds on computed vertical angles for $\Delta\theta = 20^\circ$, $\sigma_0 = 0^\circ$, and $h = 1^\circ$	17
5.5	Maximum absolute error in computed azimuthal angles for $\Delta\theta = 20^\circ$, $\sigma_0 = 0^\circ$, and $h = 4^\circ$ using a small error approximation.	19
5.6	Maximum absolute error in computed azimuthal angles for $\Delta\theta = 20^\circ$, $\sigma_0 = 0^\circ$, and $h = 4^\circ$ without using a small error approximation.	19
5.7	Error bounds on computed vertical angles for $\Delta\theta = 20^\circ$, $\sigma_0 = 0^\circ$, and $h = 4^\circ$ using a small error approximation.	20
5.8	Error bounds on computed vertical angles for $\Delta\theta = 20^\circ$, $\sigma_0 = 0^\circ$, and $h = 4^\circ$ without using a small error approximation.	20
A.1	Maximum absolute error in computed azimuthal angles for $\Delta\theta = 45^\circ$, $\sigma_0 = 1^\circ$, and $h = 0^\circ$	24
A.2	Maximum absolute error in computed azimuthal angles for $\Delta\theta = 45^\circ$, $\sigma_0 = 0^\circ$, and $h = 1^\circ$	24
A.3	Maximum absolute error in computed azimuthal angles for $\Delta\theta = 90^\circ$, $\sigma_0 = 1^\circ$, and $h = 0^\circ$	25
A.4	Maximum absolute error in computed azimuthal angles for $\Delta\theta = 90^\circ$, $\sigma_0 = 0^\circ$, and $h = 1^\circ$	25
A.5	Maximum absolute error in computed azimuthal angles for $\Delta\theta = 135^\circ$, $\sigma_0 = 1^\circ$, and $h = 0^\circ$	26
A.6	Maximum absolute error in computed azimuthal angles for $\Delta\theta = 135^\circ$, $\sigma_0 = 0^\circ$, and $h = 1^\circ$	26
A.7	Error bounds on computed vertical angles for $\Delta\theta = 45^\circ$, $\sigma_0 = 1^\circ$, and $h = 0^\circ$	27

A.8	Error bounds on computed vertical angles for $\Delta\theta = 45^\circ$, $\sigma_0 = 0^\circ$, and $h = 1^\circ$.	27
A.9	Error bounds on computed vertical angles for $\Delta\theta = 90^\circ$, $\sigma_0 = 1^\circ$, and $h = 0^\circ$.	28
A.10	Error bounds on computed vertical angles for $\Delta\theta = 90^\circ$, $\sigma_0 = 0^\circ$, and $h = 1^\circ$.	28
A.11	Error bounds on computed vertical angles for $\Delta\theta = 135^\circ$, $\sigma_0 = 1^\circ$, and $h = 0^\circ$.	29
A.12	Error bounds on computed vertical angles for $\Delta\theta = 135^\circ$, $\sigma_0 = 0^\circ$, and $h = 1^\circ$.	29

1 Introduction

A Horizontal Line Array (HLA) is a one dimensional array of sensors lying in a horizontal plane. Such an array may be used to detect and estimate the arrival direction of a signal. The use of an arrival angle as bearing estimate causes two major problems: the arrival angle does not contain any information with regard to which side of the array the signal is arriving from (this is the left-right ambiguity problem); and if an arrival angle has a non-zero vertical component, the bearing will be biased toward broadside. For arrays which can be rotated in the horizontal plane, a technique has been developed to resolve these problems [1]. Should there be errors in the observed arrival angles, the resulting estimates will show a corresponding error. The main thrust of this memorandum is to investigate the effects such errors have on the estimates of azimuthal and vertical arrival angles.

The following two sections discuss the bearing bias problem and the prescribed technique to solve it. Section 2 shows that the bias is more pronounced towards the end fire directions (signals arriving from either end of the array) compared to the broadside direction. The technique described in section 3 allows the true azimuthal and vertical arrival angles to be estimated if the array is rotated in the horizontal plane to a different orientation and a second arrival angle observation is made.

The main contribution of this memorandum is found in section 4, which deals with error bounds on the estimated azimuthal and vertical arrival angles. Given arbitrary error bounds on the arrival and rotation angles, analytic bounds on the estimates of azimuthal and vertical arrival angles are derived.

In Section 5, the analytic error bounds on the estimated azimuthal and vertical arrival angles are used to validate the case of small observation errors in reference [1] and to illustrate the discrepancies when the observation errors violate the small error restriction.

2 The HLA Bearing Bias Problem

Figure 2.1 illustrates the geometry of a plane wave signal arriving at a Horizontal Line Array (HLA) lying in the plane $\phi = 0$ where ϕ is the vertical arrival angle. The azimuthal arrival angle θ of the signal is measured clockwise from the HLA forward axis direction. For such an array, two problems arise: the first is the so-called left-right bearing ambiguity; and the second is the bearing bias. These two problems are clarified below.

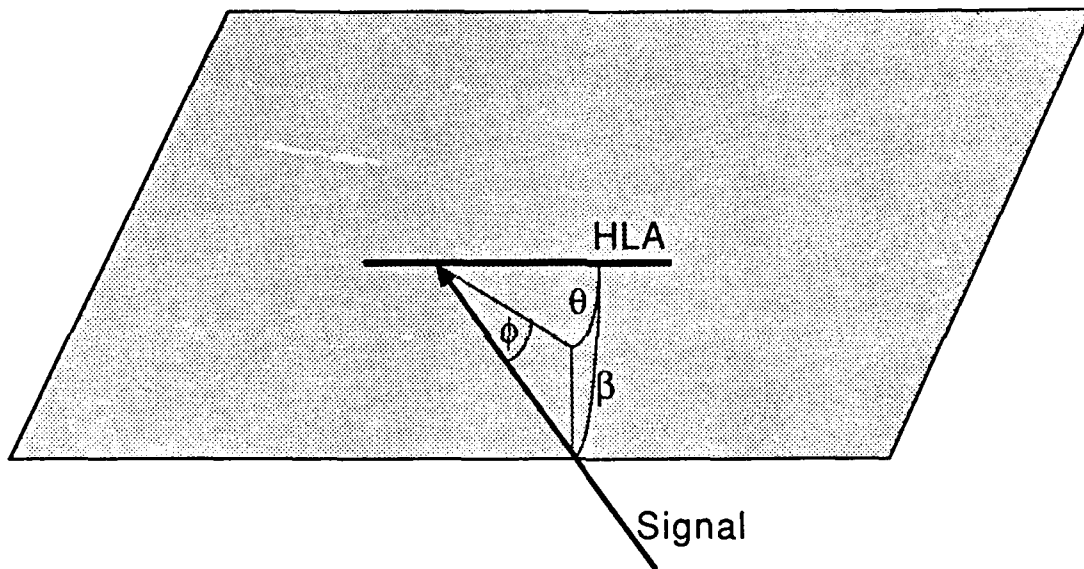

Figure 2.1: Arrival Angle Geometry

The HLA signal processing provides an estimate of β , the angle of incidence between the array axis and the signal vector. As a function of the azimuthal angle and the vertical angle, the angle β is given by

$$\cos \beta = \cos \theta \cos \phi. \quad (2.1)$$

From Equation (2.1), the angle of incidence is given by

$$\beta = \pm \cos^{-1} (\cos \theta \cos \phi) \quad (2.2)$$

which has a left-right ambiguity. Thus, if ϕ is restricted to lie between 0° and 90° , the bearing θ also has the right-left ambiguity.

If the signal is in the plane $\phi = 0^\circ$, then $\cos \beta = \cos \theta$. However, if $\phi \neq 0^\circ$, $\cos \beta$ is a biased estimator of $\cos \theta$. The effect of non-zero ϕ is to make $|\cos \beta|$ smaller than $|\cos \theta|$ so that θ is biased towards the broadside direction (where $\cos \theta = 0$).

To illustrate the seriousness of the bias B which is defined by

$$\begin{aligned} B &= \beta - \theta \\ &= \cos^{-1}(\cos \theta \cos \phi) - \theta, \end{aligned} \quad (2.3)$$

Figure 2.2 shows values of B as a function of θ for several values of ϕ between 0° and 50° . From the curves in Figure 2.2, it is evident that the vertical arrival angle can have a very significant effect and that the maximum bias occurs in the endfire directions $\theta = 0^\circ$ and $\theta = 180^\circ$.

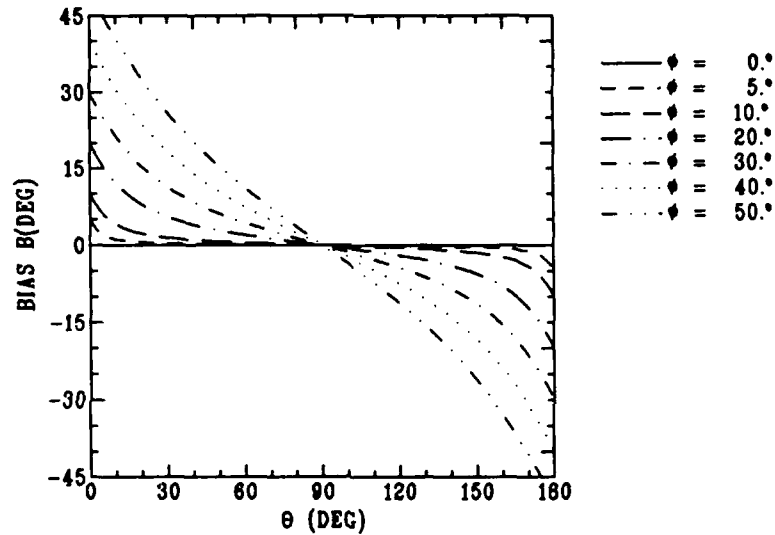

Figure 2.2: HLA Bearing Bias as a function of azimuthal angle θ , for several values of vertical arrival angle ϕ .

3 Estimation of Azimuthal and Vertical Angles

3.1 Method of Solution

The true values of the azimuthal and vertical arrival angles may be estimated if a second observation is made with the Horizontal Line Array rotated in the horizontal plane to a different orientation. For two such observations, the estimation problem can be modelled by two nonlinear equations in two unknowns. A closed form solution for this case is possible. In this section, the assumptions and restrictions on the model are presented, the analytic model is described, and the analytic solution of the azimuthal and vertical angles is given.

3.2 Assumptions and Restrictions

To find a computable closed-form solution, the following simplifying assumptions are made: 1. The array is assumed to be perfectly stable: that is, the errors due to tilting and stretching of the array are ignored. 2. The effects of motion between observations is ignored: that is, the source and receiver are assumed to be stationary. 3. The propagation path is assumed to be the same for both observations: that is, the vertical arrival angle ϕ is assumed to remain constant.

Regarding the above assumptions, the implications are as follows: 1. Array tilting may be included by enlarging the error interval for the array observations. 2. The error intervals for the input data may be enlarged to compensate for the relative motion between the source and array. 3. The assumption of constant ϕ restricts the usefulness of the method to propagation paths with stable vertical arrival angles.

3.3 The Analytic Model

Let the Horizontal Line Array be rotated in the horizontal plane through an angle $\Delta\theta$ measured in a clockwise direction and let the observed angles of incidence before and after the turn be β_1 and β_2 respectively. Let θ_1 and θ_2 be the corresponding azimuthal angles before and after the turn and ϕ_1 and ϕ_2 the corresponding vertical arrival angles. Then it is possible to describe the model by two equations and four unknowns: namely, by

$$\cos \beta_1 = \cos \theta_1 \cos \phi_1, \quad (3.1)$$

and

$$\cos \beta_2 = \cos \theta_2 \cos \phi_2. \quad (3.2)$$

The four unknowns (θ_1 , θ_2 , ϕ_1 , and ϕ_2) may be reduced to two (θ and ϕ) by assuming constant vertical arrival paths ($\phi_1 = \phi_2 = \phi$) and constant horizontal arrival paths ($\theta_1 = \theta$, and $\theta_2 = \theta - \Delta\theta$) where $\Delta\theta$ is the known rotation angle. Under these assumptions equations (3.1) and (3.2) become

$$\cos \beta_1 = \cos \theta \cos \phi \quad (3.3)$$

and

$$\cos \beta_2 = \cos(\theta - \Delta\theta) \cos \phi. \quad (3.4)$$

The vertical angle ϕ may be restricted to the interval $[0, 90]$ while the azimuthal angle θ may be restricted to $(-180, 180]$. Both of the incident angles β_1 and β_2 may be restricted to $[0, 180]$. The rotation angle $\Delta\theta$ may be restricted to $(-180, 180)$ excluding the point $\Delta\theta = 0$.

3.4 Analytic Solution

The above system of equations may be solved by expanding equation (3.4) and combining it with equation (3.3) [1]. The solutions for ϕ and θ are given by

$$\phi(\beta_1, \beta_2, \Delta\theta) = \cos^{-1} \sqrt{\left(\frac{\cos \beta_1 \cos \Delta\theta - \cos \beta_2}{\sin \Delta\theta}\right)^2 + \cos^2 \beta_1} \quad (3.5)$$

and

$$\theta(\beta_1, \beta_2, \Delta\theta) = \text{sgn}(\sin \theta(\beta_1, \beta_2, \Delta\theta)) \cos^{-1} \left(\frac{\cos \beta_1}{\cos \phi(\beta_1, \beta_2, \Delta\theta)} \right), \quad (3.6)$$

where ϕ and θ are functions of the known angles, β_1 , β_2 , and $\Delta\theta$ and where the sgn function is defined as follows:

$$\text{sgn}(x) = \begin{cases} -1 & \text{if } x < 0, \\ 0 & \text{if } x = 0, \text{ and} \\ 1 & \text{otherwise.} \end{cases} \quad (3.7)$$

Equation (3.4) may also be used to find $\sin \theta$;

$$\sin \theta(\beta_1, \beta_2, \Delta\theta) = \frac{\cos \beta_2 - \cos \beta_1 \cos \Delta\theta}{\sin \Delta\theta \cos \phi(\beta_1, \beta_2, \Delta\theta)}. \quad (3.8)$$

Equations (3.5) and (3.6) cannot be applied if $\sin \Delta\theta = 0$. This is related to the cases where the rotation is 0° and 180° . Since neither of these cases provides an effective geometry change, neither of these cases will be allowed.

Furthermore, if $\cos \phi = 0$, equations (3.6) and (3.8) cannot be applied. This is the case of the source being directly above or below the array. If $\phi = 90^\circ$, then both $\beta_1 = 90^\circ$ and $\beta_2 = 90^\circ$, and θ is indeterminate. Any value of θ will satisfy equations (3.3) and (3.4) in this case.

4 Extrema of Error Intervals

In practice the observed signal arrival angle and the rotation angle of the horizontal line array are usually known within certain error bounds. In the case of small errors (in the signal arrival angles and rotation angle), a closed-form approximation for the errors in the azimuthal and vertical arrival angles has been obtained in Reference [1]. In the case of moderate or large errors, however, no such approximation is possible. Instead, results for the latter case can be obtained conveniently through analytic expressions for the error bounds on the azimuthal and vertical arrival angles, for arbitrary error bounds on the input parameters (i.e. the signal arrival angle and the rotation angle). This section focusses on the derivation of these analytic bounds.

4.1 Method of Solution and Definitions

All of the local minima and maxima of θ and ϕ in the observation error region must be found in order to find the global minimum and maximum. The local minima and maxima can be determined by finding the values of the observed angles where the derivatives of θ or ϕ vanish. The values of θ or ϕ at such points may be compared with other such values and values on the boundary of the region to determine the global minimum or maximum.

To find the extrema, the first partial derivatives must be taken. To simplify the partial derivatives, each variable will be considered to have radians as units. The departure in units is for this section only.

Since β_1 and β_2 are only used in cosine form and since ϕ is only used in \cos^2 form, the following transformations can be used:

$$B_1 = \cos \beta_1, \quad (4.1)$$

$$B_2 = \cos \beta_2, \quad (4.2)$$

$$\Phi(B_1, B_2, \Delta\theta) = \cos^2 \phi(\beta_1, \beta_2, \Delta\theta), \quad (4.3)$$

$$\text{and } \Theta(B_1, B_2, \Delta\theta) = \theta(\beta_1, \beta_2, \Delta\theta). \quad (4.4)$$

Because of the β 's only appearing in cosine form and ϕ only appearing in \cos^2 form, the domain of the β 's can be restricted to $[0, \pi]$ and the range of ϕ can be restricted to $[0, \frac{\pi}{2}]$. This ensures that the transformations are invertable.

In addition to the above, define the limits on the error intervals as follows:

$$B_{1_{min}} = \text{minimum possible } B_1 \text{ value,}$$

$$B_{1_{max}} = \text{maximum possible } B_1 \text{ value,}$$

$B_{2_{min}}$	=	minimum possible B_2 value,
$B_{2_{max}}$	=	maximum possible B_2 value,
$\Delta\theta_{min}$	=	minimum possible $\Delta\theta$ value,
$\Delta\theta_{max}$	=	maximum possible $\Delta\theta$ value,
θ'	=	computed azimuthal arrival angle,
θ_{min}	=	lower bound on computed value of θ' ,
θ_{max}	=	upper bound on computed value of θ' ,
ϕ'	=	computed vertical arrival angle,
ϕ_{min}	=	lower bound on computed value of ϕ' ,
and ϕ_{max}	=	upper bound on computed value of ϕ' .

The angle $\Delta\theta$ may be restricted to the open interval $(0, \pi)$, which excludes the non-valid values of $\Delta\theta = 0$ and $\Delta\theta = \pi$. Recall that these angles imply that no effective geometry change has occurred. If $\Delta\theta$ is in $(-\pi, 0)$, it may be modelled by using $|\Delta\theta|$ in the calculations and negating the results for θ' . The modification of the values may be represented by the following algorithm.

$$\begin{aligned}\theta' &:= -\theta' \\ t &:= \theta_{min} \\ \theta_{min} &:= \theta_{max} \\ \theta_{max} &:= t\end{aligned}$$

The symbol $:=$ represents an assignment and t is used as a temporary variable.

Consider Φ (or Θ) as a mapping from a three dimensional real space to a one dimensional real space. The domain of possible values for B_1 , B_2 , and $\Delta\theta$ forms a cube in three dimensions. The global minimum and maximum of Φ (or Θ) may be found by comparing all local minima and maxima on the domain. Global minimum and maximum refer to the minimum and maximum over the entire domain while the local minimum and maximum refer to minimum and maximum on an arbitrarily small connected subset of the domain.

All such local minima and maxima must fall either in the interior or on the boundary of the cube. A minimum or maximum may occur at any point where a derivative fails to exist. Otherwise, if a point in the interior is a local minimum or maximum, all directional derivatives passing through that point must vanish there. If a point on the boundary is a local minimum or maximum, the conditions are slightly different.

Let \mathbf{x} be a point on the boundary where a local minimum or maximum occurs. \mathbf{x} may be a vertex, lie on an edge (but not a vertex), or lie on a face of the cube (excluding edges and vertices). Suppose \mathbf{x} lies on an edge. Two observed parameters are held constant and the partial derivative with respect to the third must vanish at \mathbf{x} . Suppose \mathbf{x} lies on a face, but not on an edge. In this case, one observed parameter is held constant and the partial derivatives with respect to the other two must vanish at \mathbf{x} . These conditions are necessary but not sufficient for the existence of a local minimum or maximum.

The following subsections contain the analysis showing necessary conditions for local minima and maxima of Θ and Φ to exist. This is done by finding the partial derivatives of Φ and

Θ and equating them to zero. Equating each of the derivatives to zero implies that a set of conditions must be satisfied. Local minima and maxima may be found by using various combinations of the implied conditions. Finally, all of the local minima and maxima are compared to find the global minimum and maximum.

As shown in the following sections, the interior of the cube may contain a maximum of Φ but no minimum. The maximum may be in the interior only if $\beta_1 = \beta_2 = \frac{\pi}{2}$ can be satisfied there. There is no local minimum or maximum of Θ in the interior. However, if the cube contains $\beta_1 = \beta_2 = \frac{\pi}{2}$, then Θ is indeterminate there and hence $\theta_{\min} = 0$ and $\theta_{\max} = \pi$.

4.2 Local Minima and Maxima of The Vertical Arrival Angle

As shown in the previous section, the solution for ϕ may be written as

$$\phi(\beta_1, \beta_2, \Delta\theta) = \cos^{-1} \sqrt{\left(\frac{\cos \beta_1 \cos \Delta\theta - \cos \beta_2}{\sin \Delta\theta}\right)^2 + \cos^2 \beta_1}. \quad (4.5)$$

Therefore, Φ may be expressed as

$$\Phi(B_1, B_2, \Delta\theta) = \left(\frac{B_1 \cos \Delta\theta - B_2}{\sin \Delta\theta}\right)^2 + B_1^2. \quad (4.6)$$

In subsections 4.2.1 and 4.2.2, the location of the minimum and maximum of ϕ (which is the same as of Φ) will be determined.

4.2.1 Local Minima and Maxima in the Interior of the Domain

Let \mathbf{x} be a point in the interior of the domain such that Φ has a local minimum or maximum at \mathbf{x} . Then each directional derivative of Φ at \mathbf{x} must vanish or fail to exist. In particular, the partial derivatives must vanish or fail to exist.

Each of the partial derivatives can be found as follows. The partial derivative with respect to B_1 is

$$\frac{\partial \Phi}{\partial B_1} = 2 \frac{B_1 - B_2 \cos \Delta\theta}{\sin^2 \Delta\theta}. \quad (4.7)$$

If $\partial \Phi / \partial B_1 = 0$ then

$$B_1 = B_2 \cos \Delta\theta. \quad (4.8)$$

The partial derivative of Φ with respect to B_2 may be written as

$$\frac{\partial \Phi}{\partial B_2} = 2 \frac{B_2 - B_1 \cos \Delta\theta}{\sin^2 \Delta\theta}. \quad (4.9)$$

If $\partial \Phi / \partial B_2 = 0$ then B_1 , B_2 , and $\Delta\theta$ must satisfy

$$B_2 = B_1 \cos \Delta\theta. \quad (4.10)$$

Finally, consider the derivative of Φ with respect to $\Delta\theta$:

$$\frac{\partial\Phi}{\partial\Delta\theta} = 2 \left(\frac{B_1 \cos \Delta\theta - B_2}{\sin \Delta\theta} \right) \left(\frac{B_2 \cos \Delta\theta - B_1}{\sin^2 \Delta\theta} \right). \quad (4.11)$$

If $\partial\Phi/\partial\Delta\theta = 0$, then either

$$B_2 = B_1 \cos \Delta\theta \quad (4.12)$$

or

$$B_1 = B_2 \cos \Delta\theta. \quad (4.13)$$

Note that each of the derivatives exists everywhere on the domain.

In order that a local minimum or maximum occur at \mathbf{x} , each of the partial derivatives must vanish. This implies that equations (4.8) and (4.10) as well as equations (4.12) or (4.13) must be satisfied. The latter two equations are exactly the same as the first two equations. In order that (4.8) and (4.10) be satisfied, both B_1 and B_2 must vanish which implies that $\beta_1 = \beta_2 = \frac{\pi}{2}$. Hence the only possible local maximum or minimum in the interior can occur at the point where $\beta_1 = \beta_2 = \frac{\pi}{2}$. This corresponds to $\phi = \frac{\pi}{2}$ which can only be a maximum and therefore a local minimum may only occur on the boundary.

4.2.2 Local Minima and Maxima on the Boundary of the Domain

Possible extrema on the faces of the domain cube will now be considered. The faces of the cube may be grouped into three disjoint sets with each set corresponding to faces with one of the three parameters being held constant. The parameter held constant may be at its minimum or maximum. Each set is discussed separately with the discussions enumerated 1 through 3.

1. Consider the two faces where B_1 is held constant: that is, $B_1 = B_{1_{min}}$ or $B_1 = B_{1_{max}}$. The partial derivatives $\partial\Phi/\partial B_2$ and $\partial\Phi/\partial\Delta\theta$ must vanish at the point where an extremum occurs. As shown in the previous discussion, each of these derivatives vanishing implies that one of equations (4.10), (4.12), or (4.13) holds. $\partial\Phi/\partial\Delta\theta = 0$ implies that either equation (4.12) or equation (4.13) must hold. $\partial\Phi/\partial B_2 = 0$ implies that equation (4.10) must be satisfied which is the same as equation (4.12). In order that both equation (4.10) and equation (4.13) hold, $B_1 = B_2 = 0$ must be satisfied. Hence either equation (4.10) or $\beta_1 = \beta_2 = \frac{\pi}{2}$ must be satisfied.

2. Repeat the same procedure with B_2 fixed: that is, $B_2 = B_{2_{min}}$ or $B_2 = B_{2_{max}}$. Therefore, both $\partial\Phi/\partial B_1$ and $\partial\Phi/\partial\Delta\theta$ must vanish simultaneously and either equation (4.8) or $B_1 = B_2 = 0$ ($\beta_1 = \beta_2 = \frac{\pi}{2}$) must be satisfied.

3. Again, repeat the same procedure with $\Delta\theta$ constant: that is, $\partial\Phi/\partial B_1 = \partial\Phi/\partial B_2 = 0$. Equations (4.8) and (4.10) must be satisfied: that is, $B_1 = B_2 = 0$ ($\beta_1 = \beta_2 = \frac{\pi}{2}$).

The conditions for local extrema on the edges will be approached in a similar fashion. Each edge corresponds to two observed parameters being held constant. There are three basic sets of edges with each set containing four edges; each set refers to the four edges corresponding to two parameters being held constant at their extrema. Each set is discussed separately with the discussions enumerated 1 through 3.

1. Consider the edges with B_1 and B_2 fixed: that is, $B_1 = B_{1_{min}}$ or $B_1 = B_{1_{max}}$ and $B_2 = B_{2_{min}}$ or $B_2 = B_{2_{max}}$. Then, for a point to be a local minimum or maximum, the partial derivative $\partial\Phi/\partial\Delta\theta$ must vanish and therefore either conditions (4.12) or (4.13) must be satisfied.

2. Now consider B_1 and $\Delta\theta$ fixed with $\partial\Phi/\partial B_2$ vanishing. $\partial\Phi/\partial B_2$ vanishing implies that equation (4.10) must be satisfied.

3. Finally, consider the edges with B_2 and $\Delta\theta$ fixed. $\partial\Phi/\partial B_1$ vanishing implies that equation (4.8) must be satisfied.

In each of the above conditions where an equation ((4.8), (4.10), (4.12), or (4.13)) must be satisfied, only one point satisfying these must be checked since Φ is constant on each of curves represented by these equations. Only the vertices are left to be checked for possible minima and maxima. Hence only a finite number of local minima and maxima must be compared to find the global minimum and maximum.

4.3 Local Minima and Maxima of Azimuthal Arrival Angle

The limits of the error interval for θ may be found in much the same manner as with ϕ . The azimuthal angle θ is given by

$$\theta(\beta_1, \beta_2, \Delta\theta) = \cos^{-1} \left(\frac{\cos \beta_1}{\cos \phi(\beta_1, \beta_2, \Delta\theta)} \right). \quad (4.14)$$

Therefore, Θ is given by

$$\Theta(B_1, B_2, \Delta\theta) = \cos^{-1} \left(\frac{B_1}{\sqrt{\Phi(B_1, B_2, \Delta\theta)}} \right). \quad (4.15)$$

As with the solution for the bounds of the error interval for Φ , the partial derivatives of Θ are required. The partial derivatives of Θ are given by

$$\frac{\partial\Theta}{\partial B_1} = -\frac{B_2}{\Phi(B_1, B_2, \Delta\theta) \sin \Delta\theta}, \quad (4.16)$$

$$\frac{\partial\Theta}{\partial B_2} = \frac{B_1}{\Phi(B_1, B_2, \Delta\theta) \sin \Delta\theta}, \quad (4.17)$$

$$\text{and } \frac{\partial\Theta}{\partial \Delta\theta} = \frac{B_1(B_1 - B_2 \cos \Delta\theta)}{\Phi(B_1, B_2, \Delta\theta) \sin^2 \Delta\theta}. \quad (4.18)$$

Equating each to zero implies that one of a number of conditions must hold. If $\partial\Theta/\partial B_1 = 0$ then

$$B_2 = 0 \quad (4.19)$$

which implies that $\beta_2 = \frac{\pi}{2}$.

If $\partial\Theta/\partial B_2 = 0$ then

$$B_1 = 0 \quad (4.20)$$

which implies that $\beta_1 = \frac{\pi}{2}$.

If $\partial\Theta/\partial\Delta\theta = 0$ then

$$B_1 (B_2 \cos \Delta\theta - B_1) = 0. \quad (4.21)$$

Each of the derivatives fail to exist if $\Phi = 0$ or $\sin \Delta\theta = 0$. $\Phi = 0$ is possible only if $\beta_1 = \beta_2 = \frac{\pi}{2}$. $\sin \Delta\theta = 0$ is not allowed.

Again, consider solutions for the extrema on the vertices, edges, faces and interior of the domain cube.

4.3.1 Local Minima and Maxima in the Interior of the Domain

In order that an extreme point occur in the interior of the domain, conditions (4.19), (4.20), and (4.21) must be satisfied at the point. This would imply that $B_1 = B_2 = 0$ and therefore, $\beta_1 = \beta_2 = \frac{\pi}{2}$ must be satisfied. This would mean that $\Phi = 0$ and therefore Θ would be indeterminate.

Hence, $\theta_{min} = 0$ and $\theta_{max} = \pi$ if $\beta_1 = \beta_2 = \frac{\pi}{2}$ is in the interior.

4.3.2 Local Minima and Maxima on the Boundary of the Domain

As in subsection 4.2.2, each of the faces and edges may be considered separately for possible extrema. There are three sets of faces to be considered; each set has a particular parameter held at its minimum or maximum. The sets are discussed separately with the discussions being enumerated 1 through 3.

1. Consider the faces with B_1 fixed: that is, $B_1 = B_{1_{min}}$ or $B_1 = B_{1_{max}}$. In order that a local minimum or maximum occurs on a face corresponding to B_1 fixed, $\partial\Theta/\partial B_1 = \partial\Theta/\partial\Delta\theta = 0$ and equations (4.20) and (4.21) must be satisfied. Satisfying these implies that the local minimum or maximum can occur only if $B_1 = 0$; i.e. $\beta_1 = \frac{\pi}{2}$.

2. Now consider the faces with B_2 fixed: that is, $B_2 = B_{2_{min}}$ or $B_2 = B_{2_{max}}$. Then $\partial\Theta/\partial B_1 = \partial\Theta/\partial\Delta\theta = 0$ at an extremum. Together, conditions (4.19) and (4.21) imply that $B_1 = B_2 = 0$ and therefore $\beta_1 = \beta_2 = \frac{\pi}{2}$ must be satisfied. Again this is the case where Θ is indeterminate.

3. Finally, consider the faces with $\Delta\theta$ fixed: that is, $\Delta\theta = \Delta\theta_{min}$ or $\Delta\theta = \Delta\theta_{max}$. In order that there be a local minima or maxima on the face, equations (4.19) and (4.20) must be satisfied. This implies that $B_1 = B_2 = 0$ or $\beta_1 = \beta_2 = \frac{\pi}{2}$. This is the case where Θ is indeterminate.

The conditions necessary for local minima or maxima in the interior and on the faces have been considered. Now consider the edges in three sets. The discussions of the three sets of four edges is enumerated 1 through 3. Each set refers to the edges defined by two parameters held at either of their extreme values.

1. Consider the edges with B_1 and B_2 fixed: that is, $B_1 = B_{1_{min}}$ or $B_1 = B_{1_{max}}$ and $B_2 = B_{2_{min}}$ or $B_2 = B_{2_{max}}$. In order that there be an extremum on one of the edges, equation

(4.21) must be satisfied. This implies that either $B_1 = 0$ or $B_2 \cos \Delta\theta = B_1$ must be satisfied. Θ is constant on the curves represented by each of these conditions which means that only one point need be found for each of the conditions.

2. Now consider B_1 and $\Delta\theta$ fixed: that is $B_1 = B_{1_{min}}$ or $B_1 = B_{1_{max}}$ and $\Delta\theta = \Delta\theta_{min}$ or $\Delta\theta = \Delta\theta_{max}$. Equation (4.20) must be satisfied at an extremum which implies that $\beta_1 = \frac{\pi}{2}$.

3. Finally, consider the edges with B_2 and $\Delta\theta$ fixed: that is, $B_2 = B_{2_{min}}$ or $B_2 = B_{2_{max}}$ and $\Delta\theta = \Delta\theta_{min}$ or $\Delta\theta = \Delta\theta_{max}$. The existence of an extreme point on the edges implies that equation (4.19) and therefore $\beta_2 = \frac{\pi}{2}$ must be satisfied.

The global extremum of Θ (and θ) may occur at any point in the domain which satisfies the above conditions or at one of the eight vertices. The possible points must be compared to find the global minimum and maximum.

4.4 Summary on Error Bounds for ϕ and θ

The preceding subsections 4.1, 4.2, and 4.3 embrace the following general results:

1. The domain of the two observed signal arrival angles ($B_1 = \cos \beta_1$, $B_2 = \cos \beta_2$) and the rotation angle ($\Delta\theta$) form a cube in three dimensions. The global minimum and maximum of ϕ and θ are found by investigating all local minima and maxima over the entire domain.

2. The interior of the cube may contain a global maximum but no local minima of ϕ .

3. It is possible that θ may be indeterminate at an interior point.

4. All other local minima and maxima of ϕ and θ occur on the boundaries of the cube.

5. Finally, only the local extrema at a finite number of points in the domain need be evaluated and compared to determine the global minimum and maximum.

The detailed descriptions of the above results have been coded in Fortran [2] and are used in the next section to obtain graphs of maximum error bounds for the azimuthal angle as well as upper and lower error bounds for the vertical arrival angles.

5 Graphic Example

The previous section presented analytic error bounds on the azimuthal and vertical arrival angles based on given observation error bounds. The effect of observation errors on the computed vertical arrival angle ϕ is considered by graphing the error bounds on ϕ as a function of the azimuthal angle θ . Similarly, the effect on the computed azimuthal angle θ is considered by graphing the maximum error on θ as a function of θ . Each is graphed for a specified rotation angle, rotation angle error, and signal arrival angle error. Other examples are presented in Appendix A.

In subsection 5.1, the errors in the observed data (the signal arrival angles and the rotation angle) are first defined. Next, in subsection 5.2, the definitions of the the bounds on the input parameters (β_1 , β_2 , and $\Delta\theta$) and the output parameters (ϕ and θ) are given. Then, in subsection 5.3, the results for the case of small observation errors are presented. Finally, in subsection 5.4, the results are given for the case where the restriction of small observation errors is violated. For consistency with the results in Reference [1], all angles are assumed to be in degrees.

5.1 Errors in Observed Data

The observation errors in the rotation and arrival angles may be defined as in the two following subsections. The error in rotation angles is constant while the error in the arrival angles is to be considered constant in the cosine space.

5.1.1 Errors in Observed Signal Arrival Angles

The absolute error in $\cos\beta$ is assumed to be independent of β and is denoted by:

$$\epsilon = \sin\sigma_0. \quad (5.1)$$

With the definition in (5.1), the error in $\cos\beta$ is constant, whereas the error in β varies as a function of β . Using this definition, σ_0 represents the error in β when β is equal to 90° (broadside). Reference [1] shows that the maximum error in β is approximately given by $10.7\sqrt{\sigma_0}$. This occurs near the endfire direction.

Therefore, the error interval for $\cos\beta$ is $[B_{min}, B_{max}]$ where

$$B_{min} = \max(-1, \cos\beta - \epsilon), \quad (5.2)$$

$$\text{and } B_{max} = \min(1, \cos\beta + \epsilon). \quad (5.3)$$

5.1.2 Errors in Rotation Angle

Further, the absolute error in $\Delta\theta$ is denoted by h ; therefore, the error interval for $\Delta\theta$ is given by $[\Delta\theta - h, \Delta\theta + h]$.

5.2 Definitions of Bounds on Various Parameters

The following definitions will be used:

$$\begin{aligned}\beta_{1_{min}} &= \cos^{-1}(\min((\cos \beta_1 + \sin \sigma_0), 1)), \\ \beta_{1_{max}} &= \cos^{-1}(\max((\cos \beta_1 - \sin \sigma_0), -1)), \\ \beta_{2_{min}} &= \cos^{-1}(\min((\cos \beta_2 + \sin \sigma_0), 1)), \\ \beta_{2_{max}} &= \cos^{-1}(\max((\cos \beta_2 - \sin \sigma_0), -1)), \\ \Delta\theta_{min} &= \Delta\theta - h, \\ \Delta\theta_{max} &= \Delta\theta + h, \\ \theta' &= \text{computed azimuthal arrival angle,} \\ \theta_{min} &= \text{lower bound on computed value of } \theta', \\ \theta_{max} &= \text{upper bound on computed value of } \theta', \\ \phi' &= \text{computed vertical arrival angle,} \\ \phi_{min} &= \text{lower bound on computed value of } \phi', \\ \text{and } \phi_{max} &= \text{upper bound on computed value of } \phi'\end{aligned}$$

where σ_0 is assumed to lie in the interval $[0, 90]$. Care has been taken through the use of the minimum and maximum functions to ensure that

$$|\cos \beta_{1_{min}}| \leq 1, \quad (5.4)$$

$$|\cos \beta_{1_{max}}| \leq 1, \quad (5.5)$$

$$|\cos \beta_{2_{min}}| \leq 1, \quad (5.6)$$

$$\text{and } |\cos \beta_{2_{max}}| \leq 1. \quad (5.7)$$

The maximum error in θ is defined by

$$\theta_{error} = \max(\theta_{max} - \theta', \theta' - \theta_{min}). \quad (5.8)$$

5.3 Results for Small Observation Errors

Reference [1] utilized a small error approximation to arrive at a closed-form solution for the errors in ϕ and θ . The small error requirement used in the earlier report can be formally written as:

$$\sin \sigma_0 \ll |\sin \Delta\theta| \cos \phi \quad (5.9)$$

$$\text{and } h \ll \frac{180}{\pi} |\sin \Delta\theta|. \quad (5.10)$$

In order to compare the results obtained by the method using the extrema of error intervals with those obtained in Reference [1](the small observation error approximation), graphs are presented below for parameters that satisfy Equations (5.9) and (5.10). This comparison serves to validate the case of small observation errors in Reference [1].

Figure 5.1 is a graph of the maximum error in the estimated azimuthal angle versus the azimuthal angle for $\Delta\theta = 20^\circ$, $\sigma_0 = 1^\circ$, and $h = 0^\circ$ (From the comments on page 13, a value of $\sigma_0 = 1^\circ$ corresponds to an error in β of about 1° at broadside increasing to about 10.7° at the endfire directions). As the vertical angle ϕ becomes steeper, the effect on the error in the computed azimuthal angle becomes larger and therefore the observation errors at these higher angles have a correspondingly larger value. Further, the largest errors occur in the endfire directions, where $\cos\theta = 1$, whereas the minimum errors occur near broadside, where $\cos\beta = 0$. Figures A.1 to A.6 in Appendix A contain similar graphs for $\Delta\theta = 45^\circ$, 90° , and 135° . These show a decrease in maximum error for $\Delta\theta = 90^\circ$.

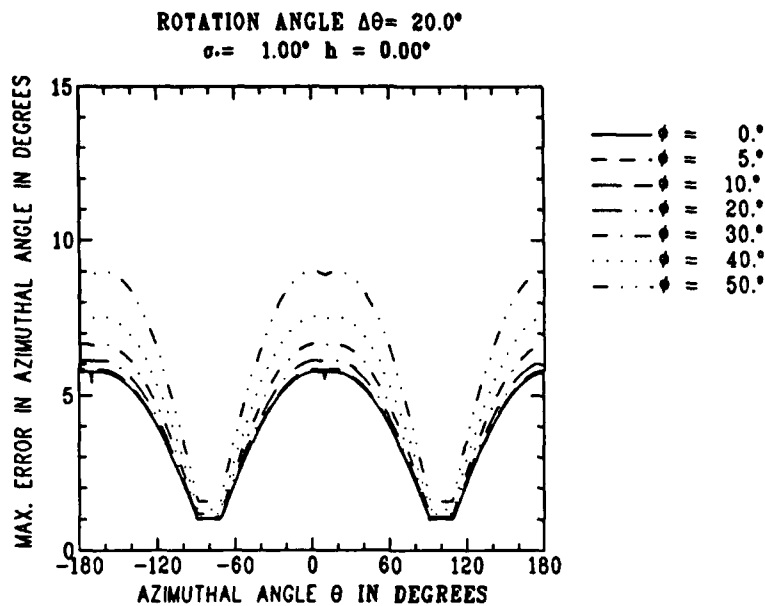

Figure 5.1: Maximum absolute error in computed azimuthal angles for $\Delta\theta = 20^\circ$, $\sigma_0 = 1^\circ$, and $h = 0^\circ$.

Figure 5.2 shows the effect of $\cos\beta$ observation errors on the calculated vertical arrival angle for the parameters $\Delta\theta = 20^\circ$, $\sigma_0 = 1^\circ$, and $h = 0^\circ$. The error bounds $\phi_{min} - \phi'$ and $\phi_{max} - \phi'$ are plotted. The maximum errors occur near broadside whereas the minimum errors occur near the endfire directions.

Figure 5.3 shows the effects of observation errors in rotation angle on the computed azimuthal angle with the parameters $\Delta\theta = 20^\circ$, $\sigma_0 = 0^\circ$, and $h = 1^\circ$. For $\Delta\theta = 20^\circ$, the maximum error in the azimuthal angle is independent of the vertical arrival angle. Figures A.7 to A.11 in Appendix A contain more graphs with $\Delta\theta = 45^\circ$, 90° , and 135° which show the same trends.

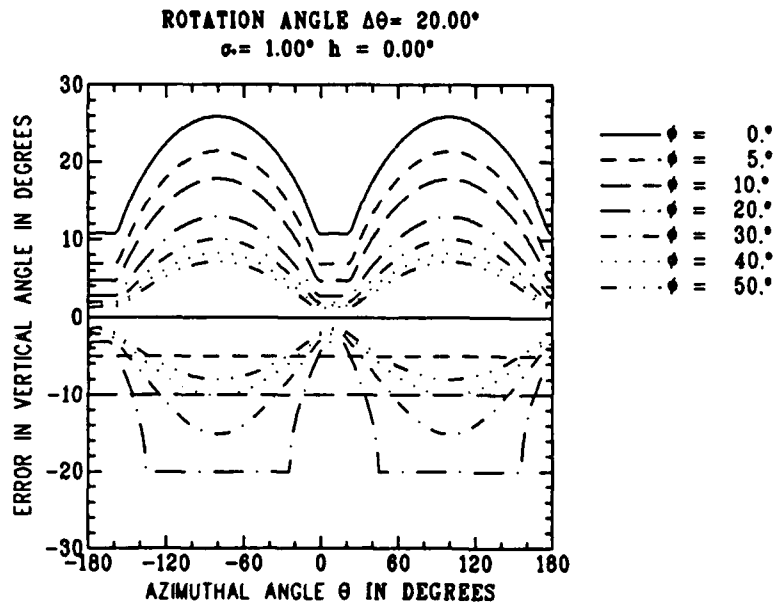

Figure 5.2: Error bounds on computed vertical angles for $\Delta\theta = 20^\circ$, $\sigma_0 = 1^\circ$, and $h = 0^\circ$.

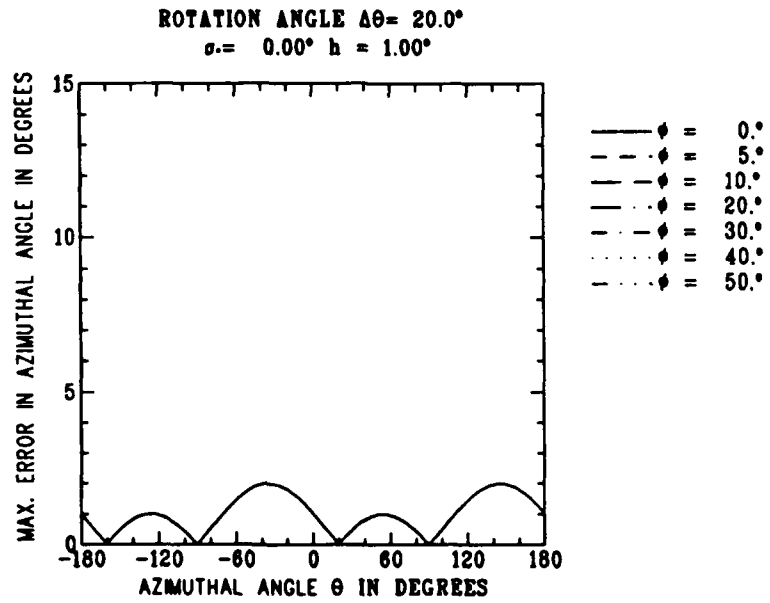

Figure 5.3: Maximum absolute error in computed azimuthal angles for $\Delta\theta = 20^\circ$, $\sigma_0 = 0^\circ$, and $h = 1^\circ$.

The errors in computed vertical arrival angles are much less influenced by errors in $\Delta\theta$ than errors in $\cos\beta$. Figure 5.4 shows the influence of errors in computed vertical arrival angles for $\Delta\theta = 20^\circ$, $\sigma_0 = 0^\circ$, and $h = 1^\circ$. This differs from the effect on computed azimuthal angles in that the errors in computed vertical arrival angles are dependent on the vertical arrival angles. The corresponding graphs with $\Delta\theta = 45^\circ$, 90° , and 135° in Appendix A also support this result.

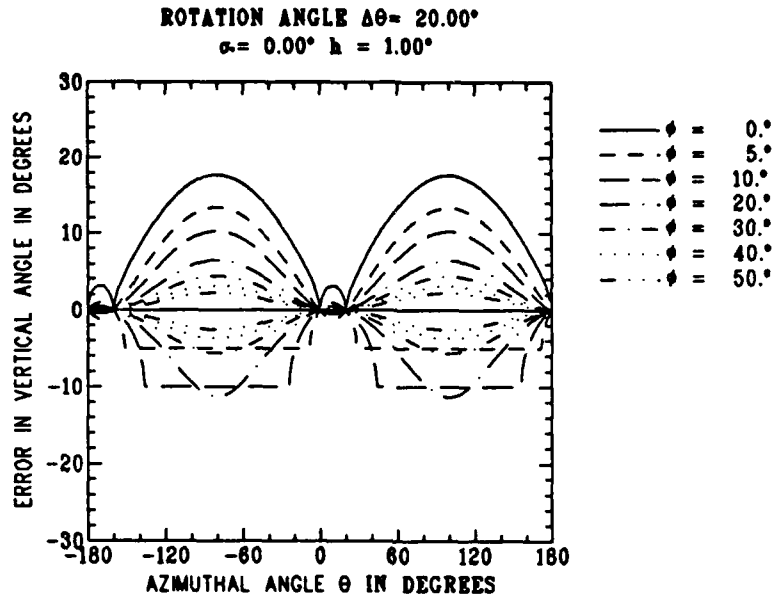

Figure 5.4: Error bounds on computed vertical angles for $\Delta\theta = 20^\circ$, $\sigma_0 = 0^\circ$, and $h = 1^\circ$.

As shown in Appendix A, the effect of errors in $\cos\beta$ on the computed azimuthal arrival angles may be minimized. Of the rotation angles used in Figure 5.1 and in Appendix A, a 90° rotation would minimize such effects. The effect of errors in $\Delta\theta$ on the computed azimuthal arrival angles are also minimized at $\Delta\theta = 90^\circ$.

The consequence of observation errors on the computed vertical arrival angle show similar trends. In fact, the effect of errors in $\cos\beta$ on the computed vertical arrival angle is minimized at $\Delta\theta = 90^\circ$. Also, the minimum effect of observation errors in $\Delta\theta$ on the computed vertical arrival angle occurs at $\Delta\theta = 90^\circ$.

Each of the above sets of example parameters was chosen to agree with previous work [1]. A comparison of the above graphs as well as those in Appendix A with the results in Reference [1] showed the same features and error magnitudes. The error magnitudes are the same within the possible accuracy measured from the graphs. Hence, the method of extrema of error intervals validates the results using the small observation error approximation.

5.4 Results for Moderate Observation Errors

The results in this subsection will illustrate the point that the approximate error bounds in Reference [1] cannot be used when the restrictions in Equations (5.9) and (5.10) are violated. For the case of moderate or large observation errors, the method using the extrema of the error intervals must be used.

Four graphs showing the effect of moderate observation errors have been prepared. The effect of errors in the observation of $\Delta\theta$ have been presented for $\Delta\theta = 20^\circ$. Graphs using the results obtained in previous work[1] have been included for comparison.

The error parameters $h = 4^\circ$ and $\sigma_0 = 0^\circ$ violate the conditions in Equation (5.10):

$$h \approx 0.2 \frac{180}{\pi} |\sin \Delta\theta|. \quad (5.11)$$

The values of these parameters are used to illustrate the discrepancies in the results obtained by the two methods. Figures 5.5 and 5.6 show the maximum absolute errors in the computed azimuthal arrival angles; Figure 5.5 makes use of the method based on the small error approximation whereas Figure 5.6 uses the method based on the extrema of error intervals. Similarly, Figures 5.7 and 5.8 show the upper and lower error bounds on the computed vertical arrival angles.

The graphs on the following two pages show noticeable differences between the methods. The approximate method (for small observation errors) tends to underestimate the error in azimuthal angle but tends to overestimate the error in vertical arrival angle. However, it can be shown that for other values of the parameters h and σ_0 , the approximate method will both underestimate and overestimate the error in azimuthal angle in different ranges of θ . Hence, the above results indicate that the method of extrema of error intervals developed in this paper should be used when the restriction of small observation errors in β and $\Delta\theta$ is no longer applicable.

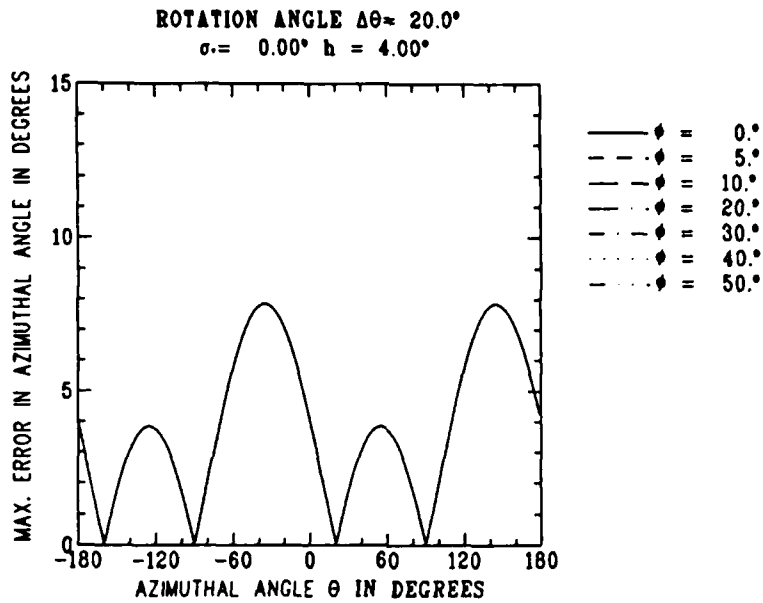

Figure 5.5: Maximum absolute error in computed azimuthal angles for $\Delta\theta = 20^\circ$, $\sigma_0 = 0^\circ$, and $h = 4^\circ$ using a small error approximation.

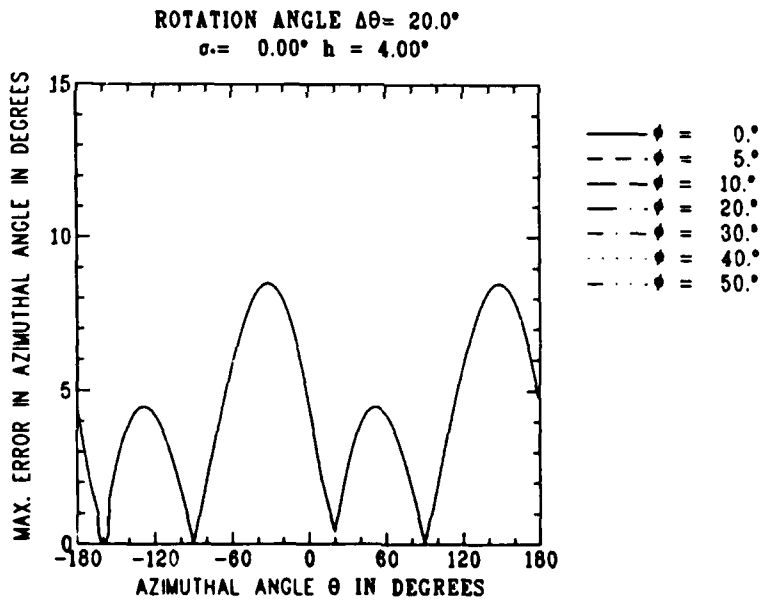

Figure 5.6: Maximum absolute error in computed azimuthal angles for $\Delta\theta = 20^\circ$, $\sigma_0 = 0^\circ$, and $h = 4^\circ$ without using a small error approximation.

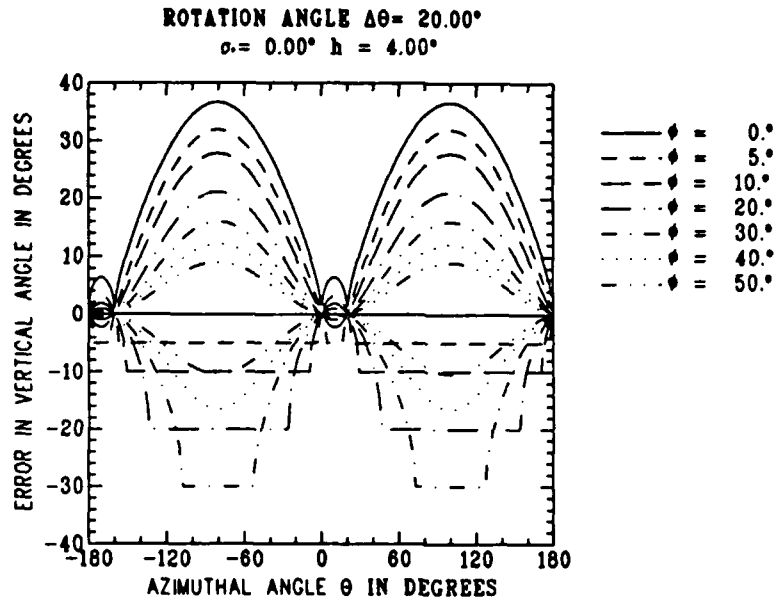

Figure 5.7: Error bounds on computed vertical angles for $\Delta\theta = 20^\circ$, $\sigma_0 = 0^\circ$, and $h = 4^\circ$ using a small error approximation.

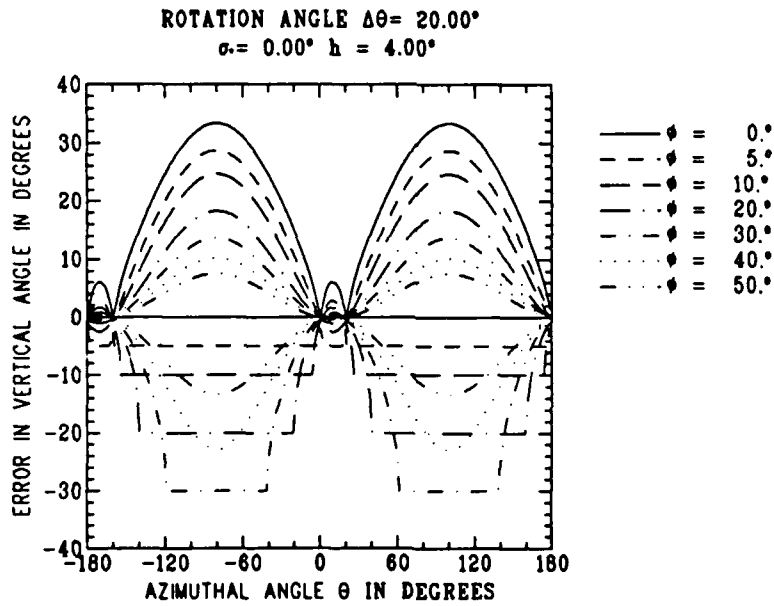

Figure 5.8: Error bounds on computed vertical angles for $\Delta\theta = 20^\circ$, $\sigma_0 = 0^\circ$, and $h = 4^\circ$ without using a small error approximation.

6 Conclusion

An earlier report showed that if a Horizontal Line Array (HLA) is rotated in the horizontal plane to a new orientation, it is possible to solve for the azimuthal and vertical arrival angles of the signal [1]. The same report gave simple expressions for r.m.s. and maximum errors in the solution when the observation errors are small.

In this report, however, the theory and method (of extrema of error intervals) are presented for computing error bounds on the solution when the observation errors are moderate to large. The method requires evaluation and comparison of possible solutions at a finite number of points. Though maximum errors in the solution are usually associated with maximum errors in the input, situations arise in which the maximum occurs at an intermediate value of the input error. This method has been implemented in Fortran code[2].

Graphs of the errors in the computed azimuthal and vertical arrival angles are presented. A comparison has been made with the previous work[1] for the cases of interest. Good agreement is found between the results of the two methods for small observation errors. Discrepancies between the two methods are shown for cases where the restriction of small observation errors is violated.

Bibliography

- [1] B. A. Trenholm and James A. Theriault, *Estimation of Azimuthal and Vertical Arrival Angles at a Rotatable Horizontal Line Array*. DREA Report R/87/101; May 1987.
- [2] James A. Theriault, *A Fortran Algorithm for Estimation of Azimuthal and Vertical Arrival Angles at a Rotatable Horizontal Line Array*. DREA, Unpublished Manuscript.

Appendix A Parametric Analysis of Maximum Azimuthal and Vertical Arrival Angle Errors for Small Observation Errors.

A number of graphs showing the effect of observation errors have been prepared to show the effect of errors in $\cos \beta$ and $\Delta \theta$ observations. These are presented here.

Graphs have been presented for rotation angles $\Delta \theta$ of 45° , 90° , and 135° . The observation error in β given by σ_0 is defined by

$$\begin{aligned}\cos(\beta_{min}) &= \min((\cos \beta + \sin \sigma_0), 1) \\ \text{and } \cos(\beta_{maz}) &= \max((\cos \beta - \sin \sigma_0), -1).\end{aligned}\tag{A.1}$$

The observation error in $\Delta \theta$, given by h , is defined by

$$\begin{aligned}\Delta \theta_{min} &= \Delta \theta - h \\ \text{and } \Delta \theta_{maz} &= \Delta \theta + h.\end{aligned}\tag{A.2}$$

For each rotation angle, graphs are presented with $h = 1^\circ$ or $\sigma_0 = 1^\circ$. The case where both σ_0 and h are non-zero is not considered.

Figures A.1 through A.6 show the maximum absolute errors on the computed azimuthal arrival angles. The maximum absolute error in θ is given by

$$\theta_{error} = \max(\theta_{maz} - \theta', \theta' - \theta_{min})\tag{A.3}$$

where θ' is a best estimate of θ . Figures A.7 through A.12 show the upper and lower error bounds on the computed vertical arrival angles given by $\phi_{maz} - \phi'$ and $\phi' - \phi_{min}$ where ϕ' is a best estimate of the vertical arrival angle ϕ .

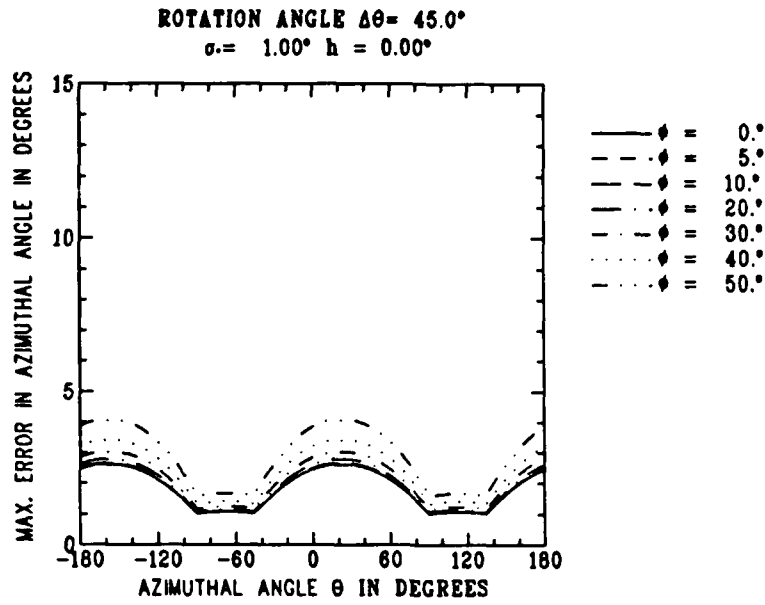

Figure A.1: Maximum absolute error in computed azimuthal angles for $\Delta\theta = 45^\circ$, $\sigma_0 = 1^\circ$, and $h = 0^\circ$.

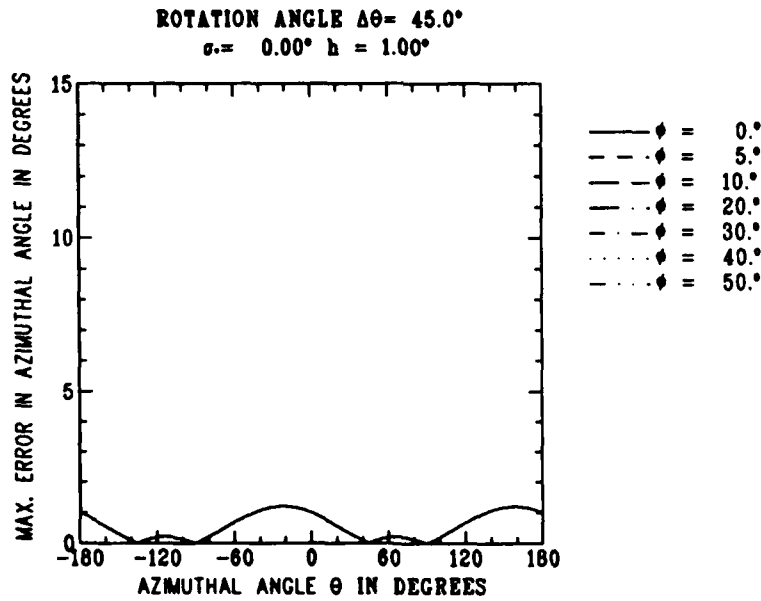

Figure A.2: Maximum absolute error in computed azimuthal angles for $\Delta\theta = 45^\circ$, $\sigma_0 = 0^\circ$, and $h = 1^\circ$.

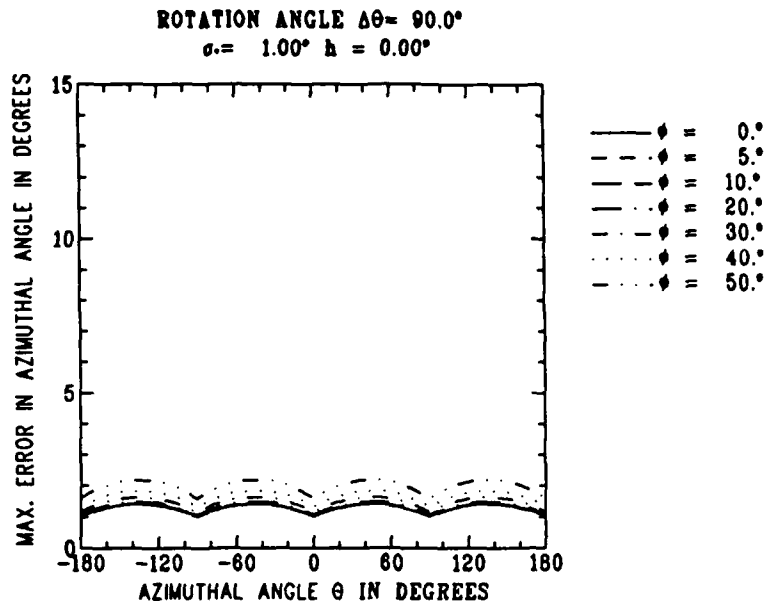

Figure A.3: Maximum absolute error in computed azimuthal angles for $\Delta\theta = 90^\circ$, $\sigma_0 = 1^\circ$, and $h = 0^\circ$.

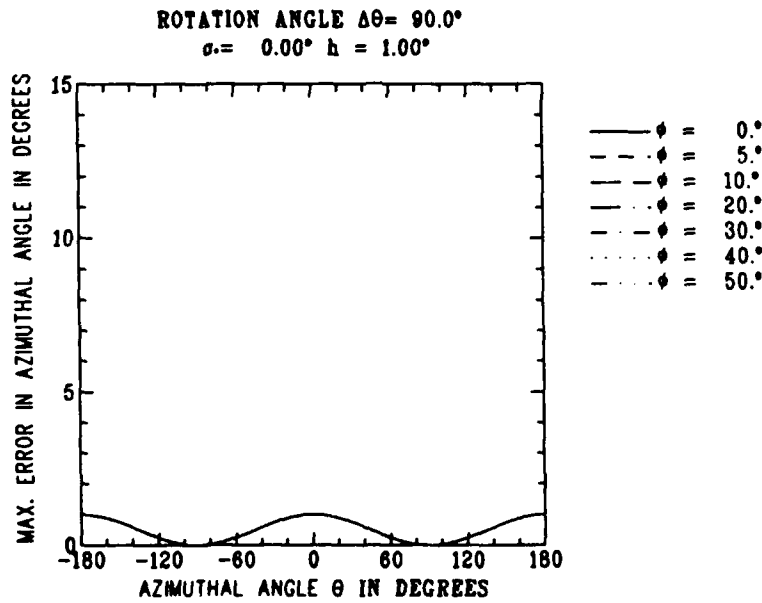

Figure A.4: Maximum absolute error in computed azimuthal angles for $\Delta\theta = 90^\circ$, $\sigma_0 = 0^\circ$, and $h = 1^\circ$.

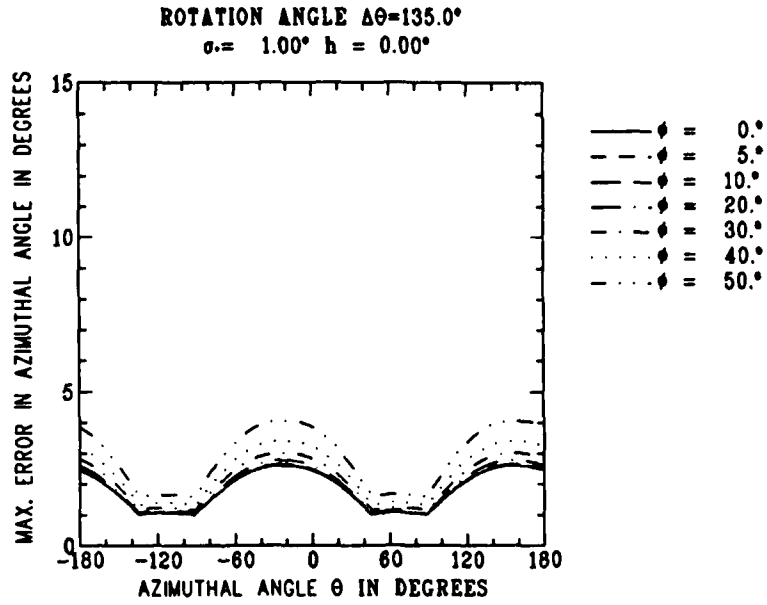

Figure A.5: Maximum absolute error in computed azimuthal angles for $\Delta\theta = 135^\circ$, $\sigma_0 = 1^\circ$, and $h = 0^\circ$.

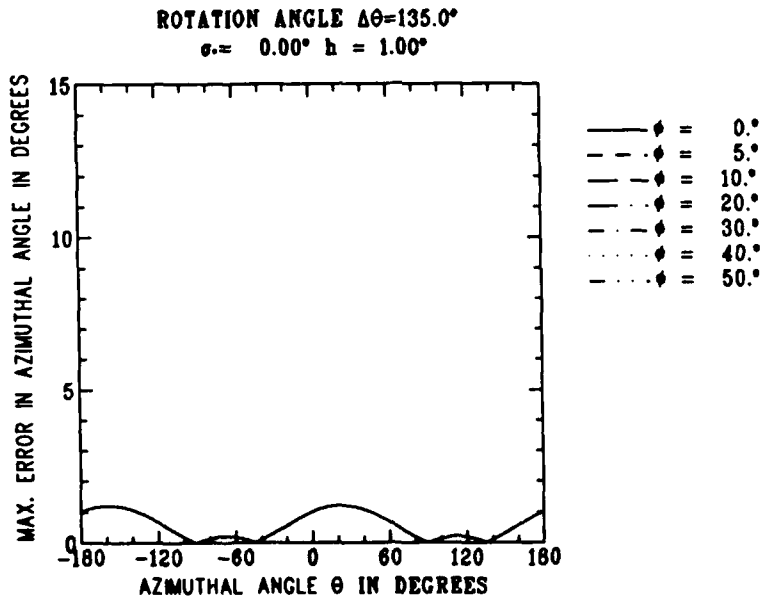

Figure A.6: Maximum absolute error in computed azimuthal angles for $\Delta\theta = 135^\circ$, $\sigma_0 = 0^\circ$, and $h = 1^\circ$.

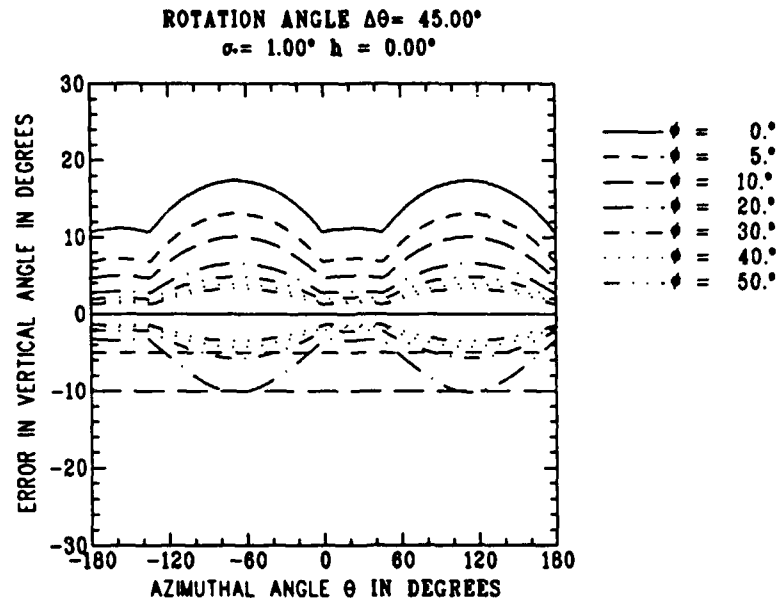

Figure A.7: Error bounds on computed vertical angles for $\Delta\theta = 45^\circ$, $\sigma_0 = 1^\circ$, and $h = 0^\circ$.

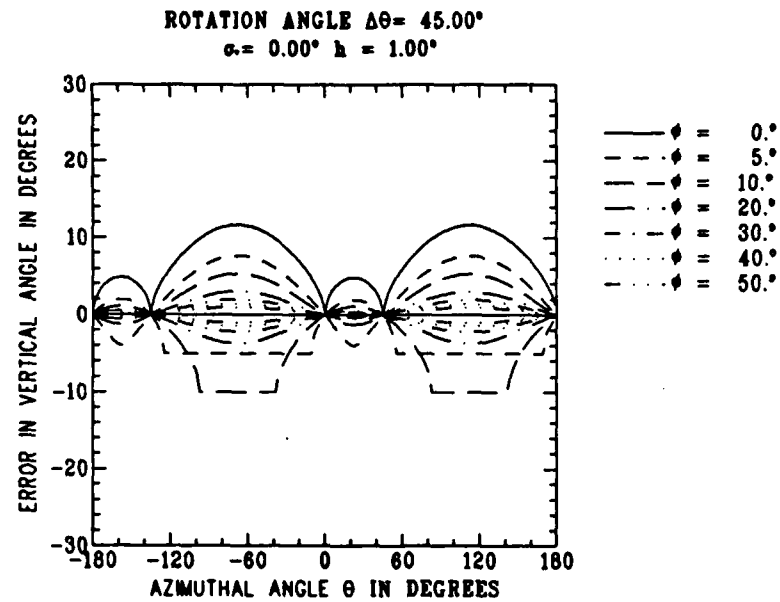

Figure A.8: Error bounds on computed vertical angles for $\Delta\theta = 45^\circ$, $\sigma_0 = 0^\circ$, and $h = 1^\circ$.

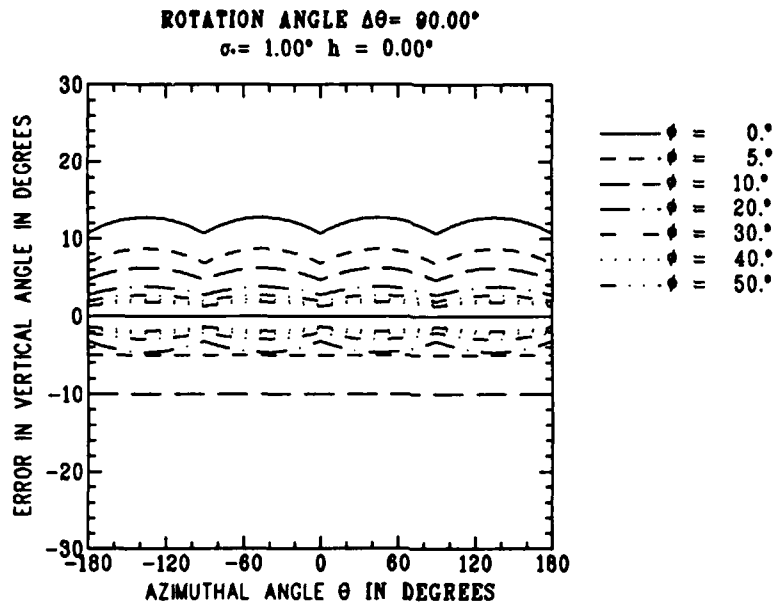

Figure A.9: Error bounds on computed vertical angles for $\Delta\theta = 90^\circ$, $\sigma_0 = 1^\circ$, and $h = 0^\circ$.

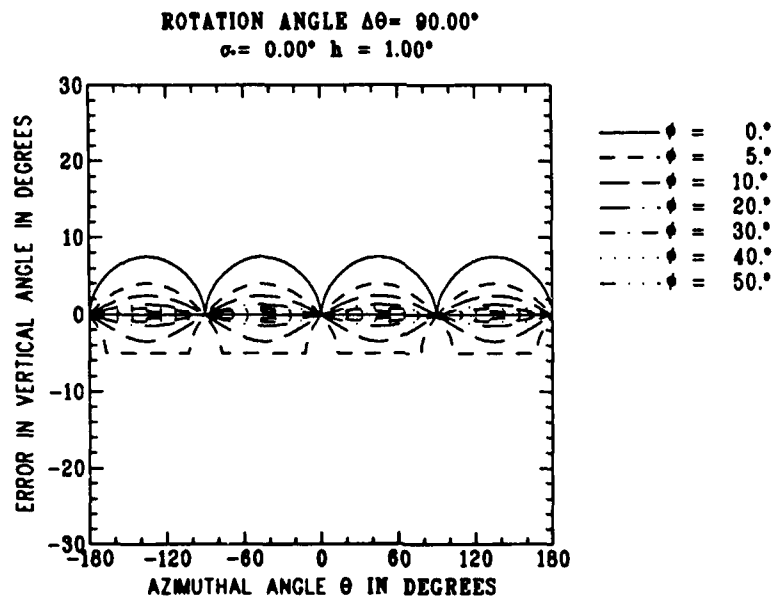

Figure A.10: Error bounds on computed vertical angles for $\Delta\theta = 90^\circ$, $\sigma_0 = 0^\circ$, and $h = 1^\circ$.

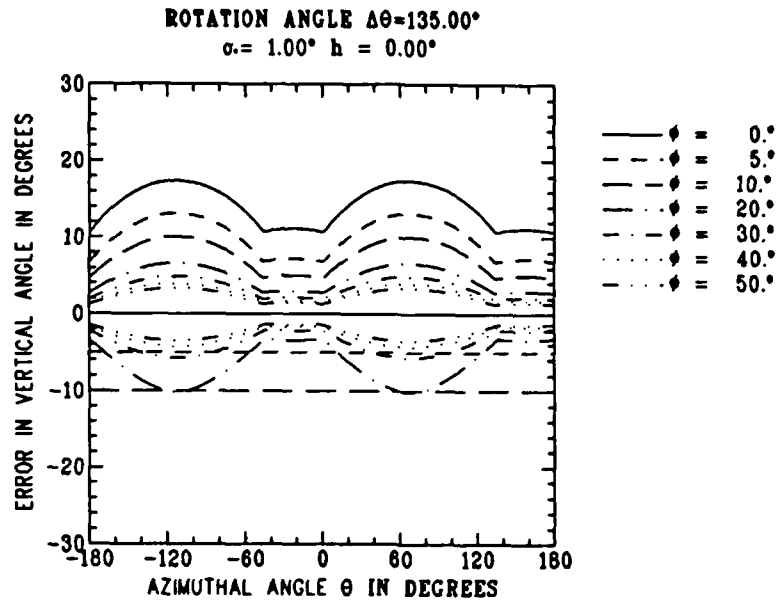

Figure A.11: Error bounds on computed vertical angles for $\Delta\theta = 135^\circ$, $\sigma_0 = 1^\circ$, and $h = 0^\circ$.

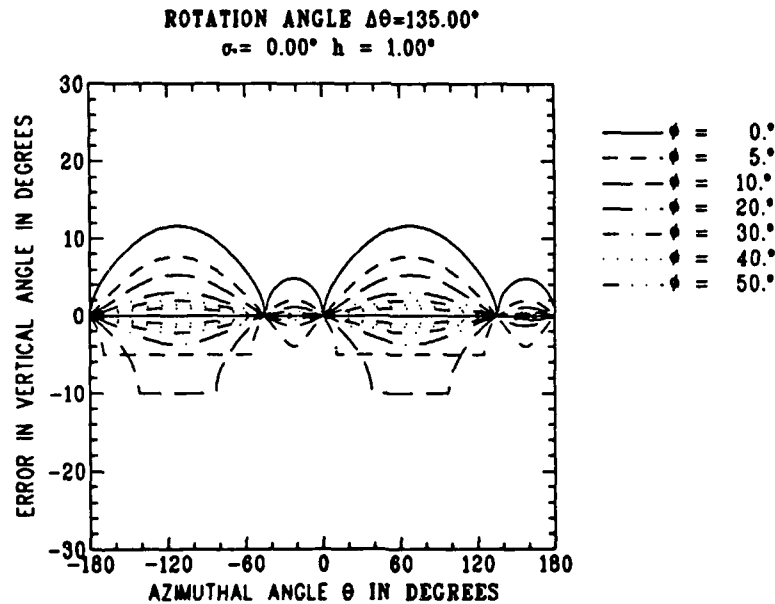

Figure A.12: Error bounds on computed vertical angles for $\Delta\theta = 135^\circ$, $\sigma_0 = 0^\circ$, and $h = 1^\circ$.

UNCLASSIFIED

SECURITY CLASSIFICATION OF FORM
(highest classification of Title, Abstract, Keywords)

DOCUMENT CONTROL DATA		
(Security classification of title, body of abstract and indexing annotation must be entered when the overall document is classified)		
1. ORIGINATOR (the name and address of the organization preparing the document. Organizations for whom the document was prepared, e.g. Establishment sponsoring a contractor's report, or tasking agency, are entered in section 8.) Defence Research Establishment Atlantic P.O. Box 1012, Dartmouth, N.S., B2Y 3Z7	2. SECURITY CLASSIFICATION (overall security classification of the document, including special warning terms if applicable) UNCLASSIFIED	
3. TITLE (the complete document title as indicated on the title page. Its classification should be indicated by the appropriate abbreviation (S,C,R or U) in parentheses after the title.) ERROR BOUNDS ON ESTIMATED AZIMUTHAL AND VERTICAL ARRIVAL ANGLES AT A ROTATABLE HORIZONTAL LINE ARRAY (U)		
4. AUTHORS (Last name, first name, middle initial. If military, show rank, e.g. Doe, Maj. John E.) THERIAULT, James A.		
5. DATE OF PUBLICATION (month and year of publication of document) February 1988	6a. NO. OF PAGES (total containing information. Include Annexes, Appendices, etc.) 37	6b. NO. OF REFS (total cited in document) 2
6. DESCRIPTIVE NOTES (the category of the document, e.g. technical report, technical note or memorandum. If appropriate, enter the type of report, e.g. interim, progress, summary, annual or final. Give the inclusive dates when a specific reporting period is covered.) DREA TECHNICAL MEMORANDUM		
8. SPONSORING ACTIVITY (the name of the department project office or laboratory sponsoring the research and development. Include the address.)		
9a. PROJECT OR GRANT NO. (if appropriate, the applicable research and development project or grant number under which the document was written. Please specify whether project or grant) DRDA06	9b. CONTRACT NO. (if appropriate, the applicable number under which the document was written)	
10a. ORIGINATOR'S DOCUMENT NUMBER (the official document number by which the document is identified by the originating activity. This number must be unique to this document.) DREA TECH. MEMORANDUM 88/202	10b. OTHER DOCUMENT NOS. (Any other numbers which may be assigned this document either by the originator or by the sponsor)	
11. DOCUMENT AVAILABILITY (any limitations on further dissemination of the document, other than those imposed by security classification) (X) Unlimited distribution () Distribution limited to defence departments and defence contractors; further distribution only as approved () Distribution limited to defence departments and Canadian defence contractors; further distribution only as approved () Distribution limited to government departments and agencies; further distribution only as approved () Distribution limited to defence departments; further distribution only as approved () Other (please specify):		
12. DOCUMENT ANNOUNCEMENT (any limitation to the bibliographic announcement of this document. This will normally correspond to the Document Availability (11). However, where further distribution beyond the audience specified in 11) is possible, a wider announcement audience may be selected.)		

UNCLASSIFIED

SECURITY CLASSIFICATION OF FORM

DC003 2/06/87

UNCLASSIFIED

SECURITY CLASSIFICATION OF FORM

13. ABSTRACT (a brief and factual summary of the document. It may also appear elsewhere in the body of the document itself. It is highly desirable that the abstract of classified documents be unclassified. Each paragraph of the abstract shall begin with an indication of the security classification of the information in the paragraph (unless the document itself is unclassified) represented as (S), (C), (R), or (U). It is not necessary to include here abstracts in both official languages unless the text is bilingual).

A Horizontal Line Array (HLA) is subject to left-right bearing ambiguity and also to bearing bias caused by non-zero vertical arrival angles. However, if a second observation is made with the array rotated to a different orientation, the azimuthal and vertical arrival angles may be estimated. For two observations where the source-array geometries are static, a closed-form solution is available. For the solution error, a closed-form approximation is also available, but only if the observation errors are small. This report deals with the case of moderate to large observation errors and presents error bounds on the estimated azimuthal and vertical arrival angles. As well, several examples are included.

14. KEYWORDS, DESCRIPTORS or IDENTIFIERS (technically meaningful terms or short phrases that characterize a document and could be helpful in cataloging the document. They should be selected so that no security classification is required. Identifiers, such as equipment model designation, trade name, military project code name, geographic location may also be included. If possible keywords should be selected from a published thesaurus, e.g. Thesaurus of Engineering and Scientific Terms (TEST) and that thesaurus-identified. If it is not possible to select indexing terms which are Unclassified, the classification of each should be indicated as with the title.)

ANTENNAS

BEAMFORMING

LINE ARRAY

UNDERWATER ACOUSTICS

CONICAL AMBIGUITY

UNCLASSIFIED

SECURITY CLASSIFICATION OF FORM