

HD-198 985

DETERMINATION OF SETTINGS OF A TILTED HEAD-CUTTER FOR
GENERATION OF HYPOI (U) ILLINOIS UNIV AT CHICAGO
CIRCLE F L LITVIN ET AL JUN 88 NASA-CR-182138
NAG3-783

171

UNCLASSIFIED

F/G 13/9

NL

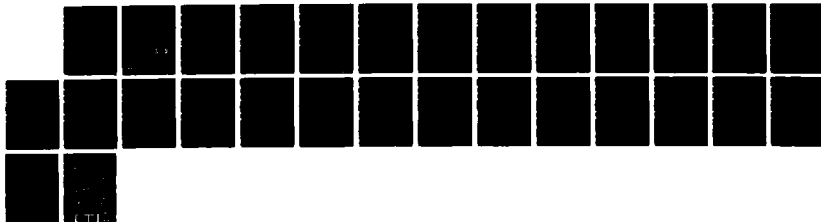

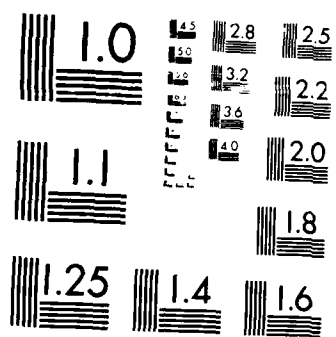

MICROCOPY RESOLUTION TEST CHART
NATIONAL BUREAU OF STANDARDS-1963-A

DTIC FILE COPY

2

NASA
Contractor Report 182138

AVSCOM
Technical Report 88-C-016

AD-A196 985

Determination of Settings of a Tilted Head-Cutter for Generation of Hypoid and Spiral Bevel Gears

F.L. Litvin and Y. Zhang
*University of Illinois at Chicago
Chicago, Illinois*

and

M. Lundy and C. Heine
*Dana Corporation
Fort Wayne, Indiana*

June 1988

DTIC
ELECTE
AUG 01 1988
S H D

Prepared for
Lewis Research Center
Under Grant NAG3-783



DISTRIBUTION STATEMENT A
Approved for public release;
Distribution Unlimited

DETERMINATION OF SETTINGS OF A TILTED HEAD-CUTTER
FOR GENERATION OF HYPOID AND SPIRAL BEVEL GEARS

F.L. Litvin and Y. Zhang
University of Illinois at Chicago
Chicago, Illinois 60688

and

M. Lundy and C. Heine
Dana Corporation
Fort Wayne, Indiana

Abstract

Kinematics of Gleason mechanisms of hypoid and spiral bevel cutting machines is considered. These mechanisms are designated to install the position and tilt the head cutter. The tilt of the head cutter with standard blades provides the required pressure angle. The authors have developed the matrix presentation of kinematics of these mechanisms and basic equations for the required settings. An example is presented based on the developed computation procedure.

1. Introduction

The synthesis of hypoid and spiral bevel gears is an important problem that has been a subject of intensive research by Gleason engineers, [1] and Litvin et al. [2]. Gleason engineers have designed machines to cut and grind hypoid and spiral bevel gears that are widely used in the industry. An ingenious mechanism is used in the Gleason gear cutting machines. This mechanism provides the required pinion pressure angle by tilting the head-cutter and thereby reducing the number of different cutter blades. A short description of the tilt head-cutter mechanism has been given by

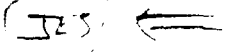
Lehmann [3] but the basic equations that are necessary for the settings have not been presented. The purpose of this paper is to investigate the kinematics of the tilt-mechanism and to derive the basic equations for the installment of the machine-tool settings. 

Henceforth we will use two coordinate systems, $S_k^{(i)}$ and $S_k^{(j)}$, that are rigidly connected to link k. However, only one coordinate system, $S_0^{(i)}$, is rigidly connected to the frame of the cutting machine and $z_0^{(i)}$ is the axis of rotation of the cradle (Fig. 1.1,a). The head-cutter is pointed to the observer. It is assumed that vectors \underline{s} and \underline{c} are known and they are represented in $S_0^{(i)}$. These vectors have been already determined at the stage of local synthesis [2]. Vector $\underline{s} = \overline{0_0^{(i)} 0_1^{(i)}}$ is located in the machine plane $z_0^{(i)} = 0$ and is represented by the row matrix (Fig. 1.1,b)

$$\underline{s} = [s \cos q \quad -s \sin q \quad 0] \quad (1.1)$$

where $s = \left| \overline{0_0^{(i)} 0_1^{(i)}} \right|$ and q determine the magnitude and orientation of vector \underline{s} .

Vector \underline{c} is the unit vector of the axis of the tilted head cutter and is represented in $S_0^{(i)}$ by the following row matrix (Fig. 1.1,b)

$$[\underline{c}_0] = [\cos p \quad -\sin p \quad \cos \mu] \quad (1.2)$$

Here: p is the angle that determines the orientation of vector \underline{c}^* , the projection of vector \underline{c} on the machine plane; μ is the angle that is formed between the axis of the cradle and the axis of the tilted head-cutter. The orientation of vector \underline{c} must satisfy the following requirements: (i) it must be perpendicular to plane P that is tangent to the root cone of the generated gear (see section A-A in Fig. 1.1,b) and (ii) the unit normal to the tilted cone of the head cutter must coincide with the

unit normal \underline{n} to the surfaces of the mating gears (see section B-B in Fig. 1.1,b). Due to the tilt of the head-cutter it becomes possible to use blades with the same shape angle ψ_c for various orientation of the surface unit normal \underline{n} (section A-A in Fig. 1.1,b).

The sketch of the mechanism for the installment of the machine-tool settings is shown in Fig. 1.2. The cradle (1) can be turned about the a-axis of the cutting machine. The cradle carries the so-called eccentric (2) that can be turned about the b-axis that is mounted on the cradle. The eccentric carries the swivel (3) that is provided with two joints whose axes are intersected and form angle ϵ . The swivel can be turned about the c-axis of the eccentric. The cutter spindle (4) is a link that is also provided with two joints, d and e, whose axes form the same angle ϵ as the joints of the swivel. The cutter spindle carries the head-cutter that rotates about the e-axis in the process of gear generation. Plane P of the blades passes through the point of intersection of axes d and e. The rotation of the head-cutter provides the desired velocity of cutting. However, when deriving the equations for the installment of machine-tool setting, we may assume that the head-cutter and the cutter spindle are rigidly connected. The tilt mechanism may be also represented as shown in Fig.1.3. The swivel and the head-cutter spindle are interconnected by the wedge. The relative motion of the cutter spindle with respect to the swivel is rotation about the d-axis that is perpendicular to the wedge.

It will be shown in section 3 of the paper that the required magnitude and orientation of position-vector \underline{s} (Fig. 1.1,b) is provided by the turning of the cradle and the eccentric. The required orientation of the unit vectors \underline{c} are provided with the turn of the swivel and the cutter spindle.



By _____	
Distribution/ _____	
Availability Codes _____	
Dist	Avail and/or Special
A-1	

2. Basic Kinematic Equations

The basic kinematic equations represent the machine-tool settings in terms of given parameters of vectors \underline{s} and \underline{c} (Fig. 1.1). The derivation of equations for settings is based on matrix representation of the coordinate transformation.

The mechanism for the installment of the machine-tool settings is shown in Fig. 1.2. The schematic of the mechanism and the applied coordinate systems are shown in Fig. 2.1. We consider that the cradle (1), the eccentric (2), the swivel (3) and the cutter spindle (4) are provided with two rigidly connected coordinate systems $S_k^{(i)}$ and $S_k^{(j)}$ ($k = 1, 2, 3, 4$). We will use for the coordinate transformation matrices of two types, G and M, that describe the link geometry, and the relative motion of interconnected links, respectively. The coordinate transformation from link 4 to link 0 is represented as follows

$$S_0^{(i)} \leftarrow S_1^{(j)} \leftarrow S_1^{(i)} \leftarrow S_2^{(j)} \leftarrow S_2^{(i)} \leftarrow S_3^{(j)} \leftarrow S_3^{(i)} \leftarrow S_4^{(j)} \leftarrow S_4^{(i)}$$

$$[M_{04}^{(ii)}] = [M_{01}^{(ij)}][G_1^{(ji)}][M_{12}^{(ij)}][G_2^{(ji)}][M_{23}^{(ij)}][G_3^{(ji)}][M_{34}^{(ij)}][G_4^{(ji)}] \quad (2.1)$$

Geometry matrix $[G^{(ji)}]$ for links 3 and 4 that are provided with two intersected axes of revolute joints is represented as follows (Fig. 2.2,a)

$$[G_\ell^{(ji)}] = \begin{bmatrix} \cos \varepsilon & 0 & (+)\sin \varepsilon & 0 \\ 0 & 1 & 0 & 0 \\ (+)\sin \varepsilon & 0 & \cos \varepsilon & 0 \\ 0 & 0 & 0 & 1 \end{bmatrix} \quad (\ell = 4, 3) \quad (2.2)$$

The upper and lower signs correspond to $\ell = 4$ and $\ell = 3$, respectively. Matrix $[G_k^{(ji)}]$ for links 2 and 1, that are provided with two parallel axes of revolute joints is represented by (Fig. 2.2,b)

$$[G_k^{(ji)}] = \begin{bmatrix} 1 & 0 & 0 & \mp l \\ 0 & 1 & 0 & 0 \\ 0 & 0 & 1 & 0 \\ 0 & 0 & 0 & 1 \end{bmatrix} \quad (2.3)$$

Here: the upper and lower signs correspond to $k = 2$ and $k = 1$, respectively.

Matrix $[M_{nm}^{(ij)}]$ is represented by the following equation (Fig. 2.3)

$$[M_{nm}^{(ij)}] = \begin{bmatrix} \cos\phi_{nm} & \sin\phi_{nm} & 0 & 0 \\ -\sin\phi_{nm} & \cos\phi_{nm} & 0 & 0 \\ 0 & 0 & 1 & 0 \\ 0 & 0 & 0 & 1 \end{bmatrix} \quad (2.4)$$

Here: $n = m - 1$; $m = 4, 3, 2, 1$. Equations (2.1) - (2.4) yield

$$[M_{04}^{(ii)}] = \begin{bmatrix} a_{11} & a_{12} & a_{13} & a_{14} \\ a_{21} & a_{22} & a_{23} & a_{24} \\ a_{31} & a_{32} & a_{33} & a_{34} \\ 0 & 0 & 0 & 1 \end{bmatrix} \quad (2.5)$$

where

$$a_{11} = \cos t (\cos^2 \epsilon \cos \phi_t + \sin^2 \epsilon) - \sin t \cos \epsilon \sin \phi_t$$

$$a_{12} = \cos t \cos \epsilon \sin \phi_t + \sin t \cos \phi_t$$

$$a_{13} = \frac{\cos t \sin 2\epsilon}{2} (1 - \cos \phi_t) + \sin t \sin \epsilon \sin \phi_t$$

$$a_{14} = l [\cos \phi_c - \cos(\phi_c + \phi_e)]$$

$$a_{21} = -\sin t (\cos^2 \epsilon \cos \phi_t + \sin^2 \epsilon) - \cos t \cos \epsilon \sin \phi_t$$

$$a_{22} = -\sin\tau\cos\epsilon\sin\phi_t + \cos\tau\cos\phi_t$$

$$a_{23} = -\frac{\sin\tau\sin 2\epsilon}{2} (1 - \cos\phi_t) + \cos\tau\sin\epsilon\sin\phi_t$$

$$a_{24} = -l[\sin\phi_c - \sin(\phi_c + \phi_e)]$$

$$a_{31} = \frac{\sin 2\epsilon}{2} (1 - \cos\phi_t)$$

$$a_{32} = -\sin\epsilon\sin\phi_t$$

$$a_{33} = \sin^2\epsilon\cos\phi_t + \cos^2\epsilon$$

$$a_{34} = 0 \quad (2.6)$$

Here: $\tau = (\phi_c + \phi_e + \phi_s)$; $\phi_c = \phi_{01}$ is the cradle angle; $\phi_e = \phi_{12}$ is the eccentric angle; $\phi_s = \phi_{23}$ is the swivel angle and $\phi_t = \phi_{34}$ is the cutter spindle angle. We will also need the coordinate transformation: (i) from $S_2^{(i)}$ to $S_0^{(i)}$ and (ii) from $S_4^{(i)}$ to $S_2^{(i)}$. Using the matrix equations (2.2) - (2.4), we obtain

$$\begin{aligned} [M_{02}^{(ii)}] &= [M_{01}^{(ij)}][G_1^{(ji)}][M_{12}^{(ij)}][G_2^{(ji)}] \\ &= \begin{bmatrix} \cos(\phi_c + \phi_e) & \sin(\phi_c + \phi_e) & 0 & l[\cos\phi_c - \cos(\phi_c + \phi_e)] \\ -\sin(\phi_c + \phi_e) & \cos(\phi_c + \phi_e) & 0 & -l[\sin\phi_c - \sin(\phi_c + \phi_e)] \\ 0 & 0 & 1 & 0 \\ 0 & 0 & 0 & 1 \end{bmatrix} \end{aligned} \quad (2.7)$$

$$\begin{aligned} [M_{24}^{(ii)}] &= [M_{23}^{(ij)}][G_3^{(ji)}][M_{34}^{(ij)}][G_4^{(ji)}] \\ &= \begin{bmatrix} b_{11} & b_{12} & b_{13} & 0 \\ b_{21} & b_{22} & b_{23} & 0 \\ b_{31} & b_{32} & b_{33} & 0 \\ 0 & 0 & 0 & 1 \end{bmatrix} \end{aligned} \quad (2.8)$$

Here:

$$b_{11} = \cos\phi_s (\cos^2\epsilon \cos\phi_t + \sin^2\epsilon) - \sin\phi_s \cos\epsilon \sin\phi_t$$

$$b_{12} = \cos\phi_s \cos\epsilon \sin\phi_t + \sin\phi_s \cos\phi_t$$

$$b_{13} = \frac{\sin 2\epsilon}{2} (1 - \cos\phi_t) \cos\phi_3 + \sin\phi_s \sin\epsilon \sin\phi_t$$

$$b_{21} = -\sin\phi_s (\cos^2\epsilon \cos\phi_t + \sin^2\epsilon) - \cos\phi_s \cos\epsilon \sin\phi_t$$

$$b_{22} = -\sin\phi_s \cos\epsilon \sin\phi_t + \cos\phi_s \cos\phi_t$$

$$b_{23} = -\frac{\sin\phi_s \sin 2\epsilon}{2} (1 - \cos\phi_t) + \cos\phi_s \sin\epsilon \sin\phi_t$$

$$b_{31} = \frac{\sin 2\epsilon}{2} (1 - \cos\phi_t)$$

$$b_{32} = -\sin\epsilon \sin\phi_t$$

$$b_{33} = \sin^2\epsilon \cos\phi_t + \cos^2\epsilon \quad (2.9)$$

3. Determination of Machine-Tool Settings

Determination of Cradle Angle and Eccentric Angle

Consider that vector \underline{s} is given and it is represented in the machine plane $z_0^{(i)} = 0$ as follows

$$[s] = \begin{bmatrix} s \cos q \\ -s \sin q \\ 0 \\ 1 \end{bmatrix} \quad (3.1)$$

where s and q are known values that have been determined at the stage of local synthesis [2]. To determine the eccentric angle and the cradle angle, we use

the following matrix equation

$$\begin{bmatrix} s \cos q \\ -s \sin q \\ 0 \\ 1 \end{bmatrix} = [M_{02}^{(ii)}] \begin{bmatrix} 0 \\ 0 \\ 0 \\ 1 \end{bmatrix} \quad (3.2)$$

where $[0 \ 0 \ 0 \ 1]$ are the coordinates of point $O_2^{(i)}$ in $S_2^{(i)}$. Equations (3.2) and (2.7) yield

$$s \cos q = \ell [\cos \phi_c - \cos(\phi_c + \phi_e)] \quad (3.3)$$

$$s \sin q = \ell [\sin \phi_c - \sin(\phi_c + \phi_e)] \quad (3.4)$$

where ℓ is a constant - the distance between the centers of the cradle and the eccentric. After transformations of equations (3.3) and (3.4), we obtain

$$\frac{s}{2\ell} \cos q = \sin \frac{\phi_e}{2} \sin(\phi_c + \frac{\phi_e}{2}) \quad (3.5)$$

$$\frac{s}{2\ell} \sin q = -\sin \frac{\phi_e}{2} \cos(\phi_c + \frac{\phi_e}{2}) \quad (3.6)$$

Equations (3.5) and (3.6) provide in the area of $0 < \phi_e < 2\pi$, $0 < \phi_c < 2\pi$ two solutions for ϕ_e and ϕ_c represented by the following equations

$$\phi_e = 2 \arcsin \frac{s}{2\ell} \quad (3.7)$$

$$\phi_c = q + 90^\circ - \frac{\phi_e}{2} \quad (3.8)$$

The two solutions are related as follows

$$\phi_e^{(2)} = 2\pi - \phi_e^{(1)} \quad \phi_c^{(2)} = \phi_c^{(1)} + \phi_e^{(1)} - \pi \quad (3.9)$$

The obtained results show that the required magnitude and orientation of vector \underline{s} may be obtained by two combinations of parameters of machine-tool settings, ϕ_c and ϕ_e . Fig. 3.1 and Fig. 3.2 illustrate the installment of the cradle angle, ϕ_c , and eccentric angle, ϕ_e , for the cases where a left-hand pinion and a right-hand pinion are generated. In the practice only the first solution for the parameters ϕ_e and ϕ_c is applied (with $0 < \phi_e < \pi$).

Determination of Cutter Spindle Angle and Swivel Angle

The combination of the cutter spindle angle, ϕ_t , and the swivel angle, ϕ_s , provides the required orientation of the unit vector \underline{c} of the tilted head cutter. The purpose of this section is to derive the equations that represent ϕ_t and ϕ_s in terms of the components of vector \underline{c} . The eccentric angle, ϕ_e , and the cradle angle, ϕ_c , are considered as known at this stage of derivations. We will use for the derivation of the swivel angle two alternative techniques.

First Technique Consider that vector \underline{c} is represented in $S_0^{(i)}$ by the row matrix

$$\underline{c}_0 = [c_{x0} \quad c_{y0} \quad c_{z0}] = [c_{x0} \quad c_{y0} \quad \cos\mu] \quad (3.10)$$

where μ is the angle that is formed by the cradle axis, $z_0^{(i)}$, and the axis of the tilted head cutter. The orientation of the axis of the tilted head-cutter is represented in $S_0^{(i)}$ by the elements a_{13} , a_{23} , and a_{33} . Here: a_{13} , a_{23} , and a_{33} are the direction cosines that are formed by axis $z_4^{(i)}$ (the head-cutter axis) and the axes $x_0^{(i)}$, $y_0^{(i)}$ and $z_0^{(i)}$ (see matrix (2.5)).

The cutter spindle angle can be determined from the equation

$$a_{33} = \cos\mu \quad (3.11)$$

Equating equation (3.11) and using the expression for a_{33} (see equations (2.6)), we obtain

$$\sin^2\epsilon \cos\phi_t + \cos^2\epsilon = \cos\mu \quad (3.12)$$

Equation (3.11) yields

$$\sin \frac{\phi_t}{2} = \frac{\sin \frac{\mu}{2}}{\sin\epsilon} \quad (3.13)$$

This equation provides two solutions for the cutter spindle angle, ϕ_t , considering that the magnitude of μ is given. The two solutions for ϕ_t are related as follows

$$\phi_t^{(2)} = 2\pi - \phi_t^{(1)} \quad (3.14)$$

In the practice only the first solution for $\phi_t^{(1)}$ ($0 < \phi_t^{(1)} < \pi$) is used. The derivation of the swivel angle is based on equations

$$a_{13} = c_{x_0}, \quad a_{23} = c_{y_0} \quad (3.15)$$

Using the expressions for a_{13} and a_{23} (see equations (2.6)), we obtain

$$\frac{\cos\epsilon \sin 2\epsilon}{2} (1 - \cos\phi_t) + \sin\epsilon \sin\epsilon \sin\phi_t = c_{x_0} \quad (3.16)$$

$$-\frac{\sin\tau\sin 2\epsilon}{2}(1 - \cos\phi_t) + \cos\tau\sin\epsilon\sin\phi_t = c_{y0} \quad (3.17)$$

where $\tau = \psi_c + \psi_e + \psi_s$.

We may transform equations (3.16) and (3.17) and represent them as a system of two pseudo-linear equations in the unknowns $\cos\tau$ and $\sin\tau$ as follows

$$\begin{aligned} a_{11} \cos\tau + a_{12} \sin\tau &= b_1 \\ a_{21} \cos\tau - a_{22} \sin\tau &= b_2 \end{aligned} \quad (3.18)$$

Here:

$$\begin{aligned} a_{11} = a_{22} &= \sin 2\epsilon \sin^2 \frac{\phi_t}{2} ; a_{12} = a_{21} = \sin\epsilon \sin\phi_t ; \\ b_1 &= c_{x0}, \quad b_2 = c_{y0} \end{aligned} \quad (3.19)$$

The solution of equation system (3.18) for the unknowns is

$$\cos\tau = \frac{a_{11}b_1 + a_{12}b_2}{a_{11}^2 + a_{12}^2} = A \quad (3.20)$$

$$\sin\tau = \frac{a_{21}b_1 - a_{11}b_2}{a_{11}^2 + a_{12}^2} = B$$

or

$$\tan \frac{\tau}{2} = \frac{1 - A}{B} \quad (3.20,a)$$

Then we obtain that

$$\phi_s = \tau - \phi_c - \phi_e \quad (3.21)$$

Second Technique

Consider that vector ζ is represented in coordinate system $S_2^{(i)}$ that is rigidly connected to the eccentric and is given by the row matrix

$$[c_2] = [c_{x2} \quad c_{y2} \quad c_{z2}]$$

Here:

$$[c_2] = [L_{20}^{(ii)}][c_o] \quad (3.22)$$

where $[L_{20}^{(ii)}]$ represents the coordinate transformation from $S_0^{(i)}$ to $S_2^{(i)}$ and is given by (see equation (2.7))

$$\begin{aligned} [L_{20}^{(ii)}] &= [L_{02}^{(ii)}]^T \\ &= \begin{bmatrix} \cos(\phi_c + \phi_e) & -\sin(\phi_c + \phi_e) & 0 \\ \sin(\phi_c + \phi_e) & \cos(\phi_c + \phi_e) & 0 \\ 0 & 0 & 1 \end{bmatrix} \end{aligned} \quad (3.23)$$

The unit vector of the axis of tilted head-cutter is represented in $S_2^{(i)}$ by its direction cosines b_{13} , b_{23} and b_{33} (see matrix (2.9)). The determination of the cutter spindle angle, ϕ_t , and the swivel angle, ϕ_s , is based on the following equations

$$b_{13} = c_{x2}, \quad b_{23} = c_{y2}, \quad b_{33} = c_{z2} \quad (3.24)$$

Equation $b_{33} = c_{z2}$ provides the same solution for ϕ_t as it has been represented by equation (3.12). Using the remaining two equations

$$b_{13} = c_{x2}, \quad b_{23} = c_{y2}$$

we obtain after transformations the following system of two pseudo-linear equations in the unknowns $\cos\phi_s$ and $\sin\phi_s$

$$m_{11} \cos\phi_s + m_{12} \sin\phi_s = n_1 \quad (3.25)$$

$$m_{21} \cos\phi_s + m_{22} \sin\phi_s = n_2 \quad (3.26)$$

Here:

$$m_{11} = \frac{\sin 2\epsilon}{2} (1 - \cos\phi_t), \quad m_{12} = \sin\epsilon \sin\phi_t$$

$$m_{21} = m_{12}, \quad m_{22} = -m_{11}, \quad n_1 = c_{x2}, \quad n_2 = c_{y2}$$

The solution of equations (3.25) and (3.26) for the unknowns $\cos\phi_s$ and $\sin\phi_s$ yields

$$\cos\phi_s = \frac{\frac{m_{11}n_1}{2} + \frac{m_{12}n_2}{2}}{m_{11} + m_{12}} = C \quad (3.27)$$

$$\sin\phi_s = \frac{\frac{m_{12}n_1}{2} - \frac{m_{11}n_2}{2}}{m_{11} + m_{12}} = D \quad (3.28)$$

where $m_{11}^2 + m_{12}^2 = 4\sin^2\epsilon \sin^2\frac{\phi_t}{2} \cos^2\frac{\mu}{2}$

or

$$\tan \frac{\phi_s}{2} = \frac{1 - C}{D} \quad (3.29)$$

Numerical Example

The input data in the discussed example is adopted from literature [2] and is represented in coordinate system $S_0^{(i)}$ as follows (length units in mm):

$$\underline{s} = [133.09 \cos(84.033^0); -133.09 \sin(84.033^0); 0]$$

$$\underline{c} = [0.1085; -0.1157; 0.9874]; \quad \lambda = 222.25; \quad \epsilon = 15^0$$

$$\cos \eta = c_2 = 0.9874$$

The following computations has been performed for the Gleason Cutting Machine #116. Equations (3.7) and (3.8) provide the data for the eccentric angle, ϕ_e , and the cradle angle, ϕ_c . Equation (3.13) provides the data for the cutter spindle angle, ϕ_t . Equations (3.21), (3.20) and (3.19) provide the data for the swivel angle, ϕ_s . Alternative equations (3.27) and (3.28) for determination of ϕ_s may be also used.

The final results of computations are represented in the following table

TABLE 1

Eccentric Angle, ϕ_e	Cradle Angle, ϕ_c	Cutter Spindle Angle, ϕ_t	Swivel Angle, ϕ_s
73.57°	137.25°	35.7175°	268.10°

Conclusion

The kinematics of the Gleason's mechanism for the installment of the machine-tool settings has been investigated.

The basic equations for the determination of the eccentric angle, cradle angle, cutter spindle angle and the swivel angle for the gear cutting machine have been developed. These equations provide the required magnitude and orientation of position-vector \underline{s} and the orientation of unit vector \underline{c} of the axis of the tilted head-cutter axis (Fig. 1.1,b).

A numerical example that illustrates the proposed computation procedure has been represented.

Nomenclature

c	Unit vector of tilted head-cutter axis
l	Machine constant
P	Angle determining the projection of cutter axis on machine plane
q	Basic cradle angle determining location of cutter axis
s	Radial setting for pinion head-cutter axis
μ	Angle of head-cutter axis inclined with cradle axis
ε	Wedge angle
ϕ_c	Cradle angle
ϕ_l	Eccentric angle
ϕ_s	Swivel angle
ϕ_t	Cutter spindle angle

References

1. Gleason Works, 1981, "Understanding Tooth Contact Analysis", Rochester, N.Y., 14692, Publication No. SD3139.
2. Litvin, F.L., and Gutman, Y.I., 1981, Methods of Synthesis and Analysis for Hypoid-Gear Drives of "Formate" and "Helix-form", J. of Mechanical Design, Vol. 103, pp. 89-113.
3. Lehmann, E.P., 1977, Tilt Generation of Spiral Bevel and Hypoid Gears, Gleason Works.

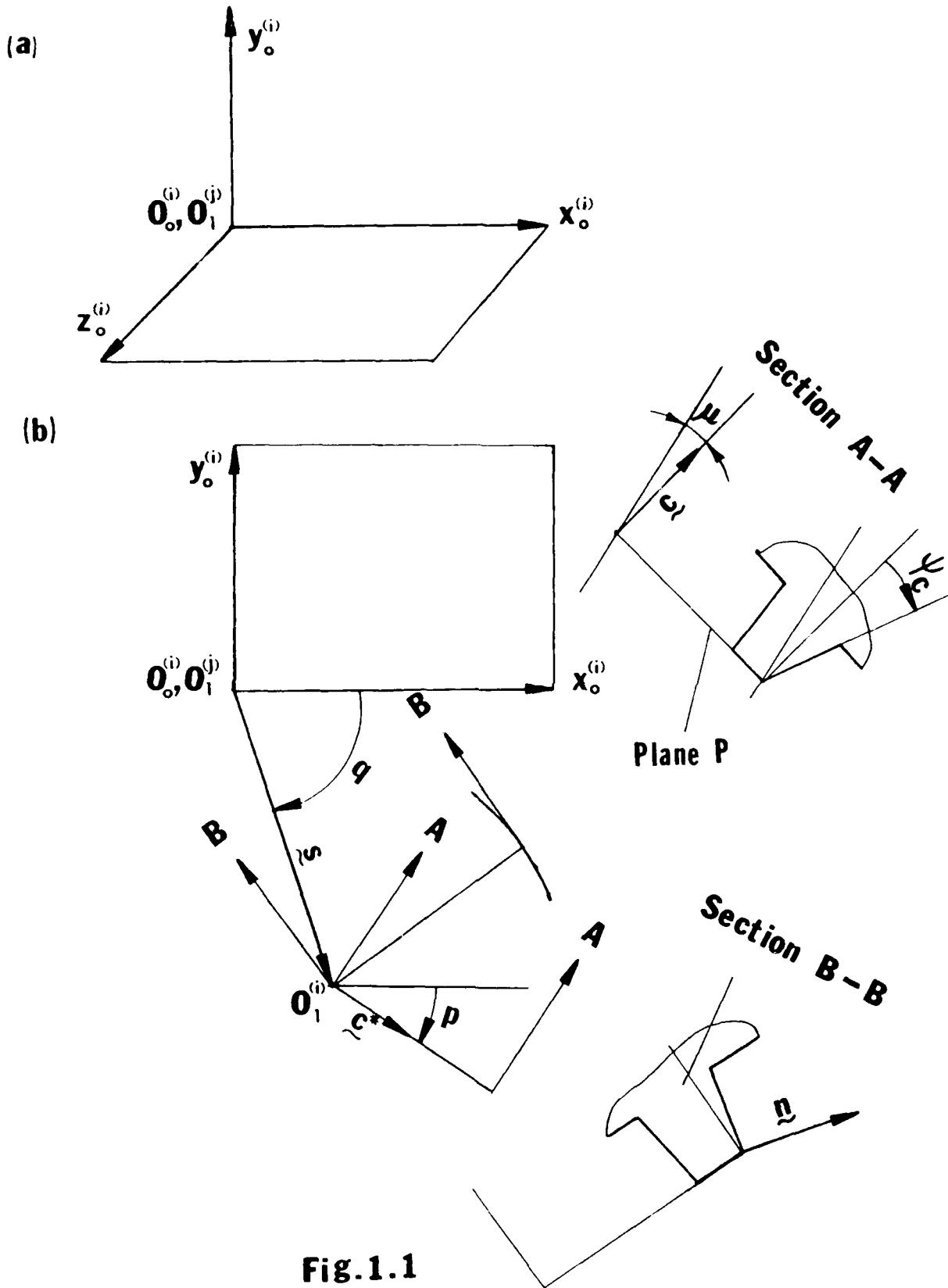

Fig.1.1
Basic Coordinate System

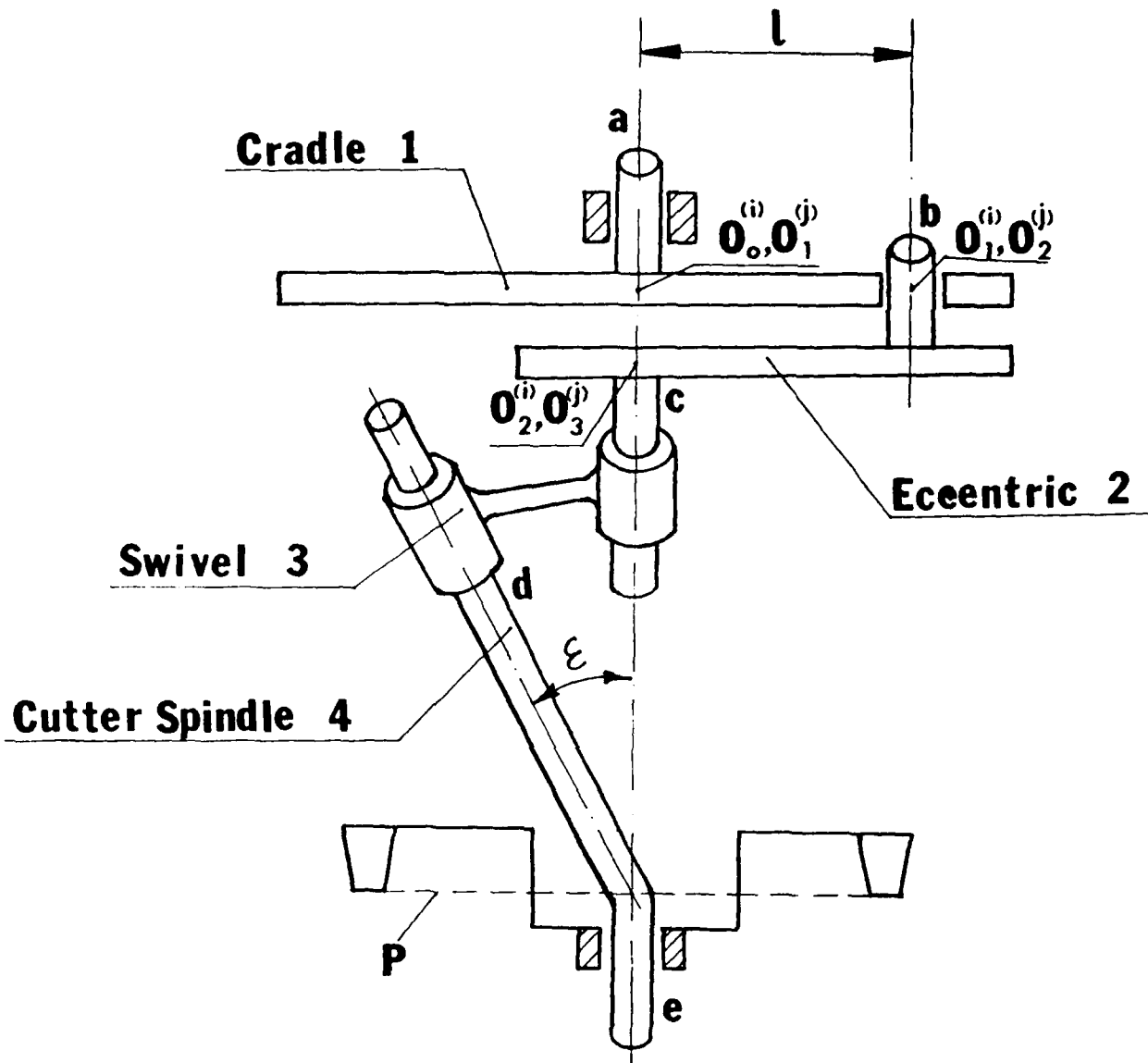

Fig.1.2
Installment Mechanism

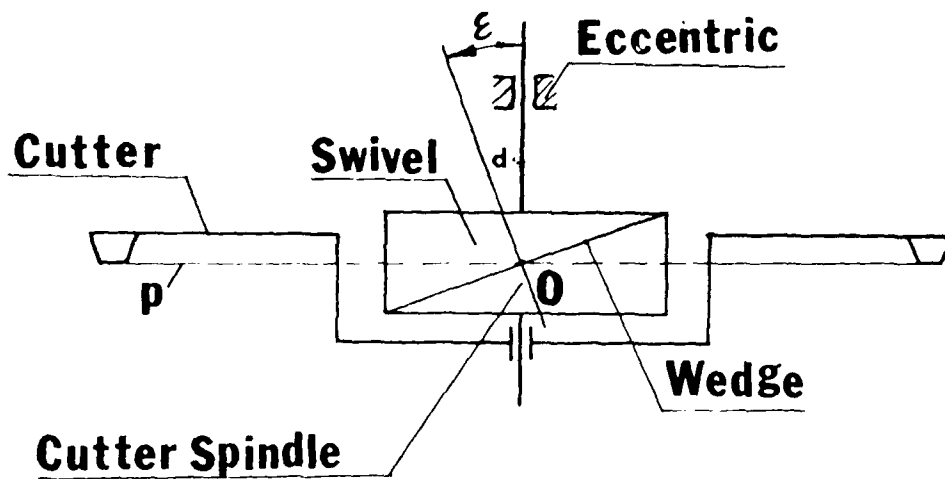

Fig. 1.3
Tilt Mechanism

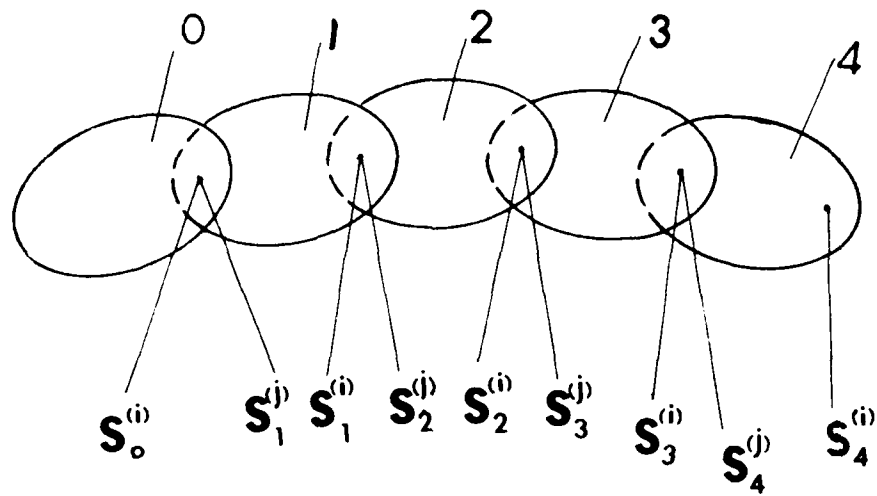
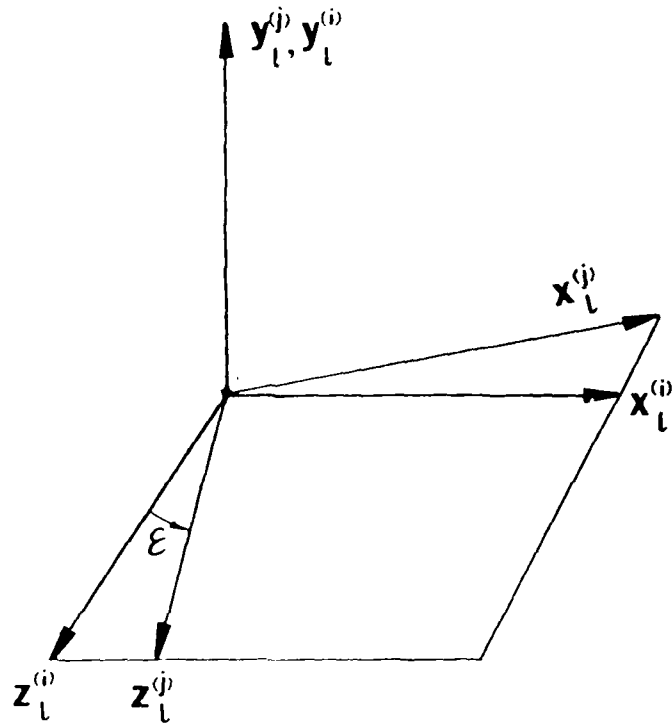

Fig. 2.1
Applied Coordinate Systems

(a)



(b)

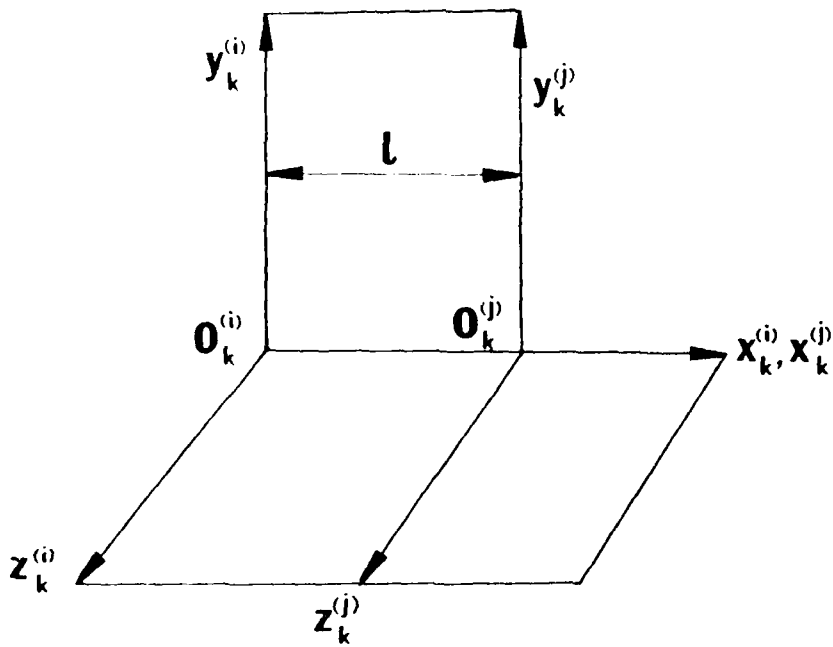

Fig. 2.2

Coordinate Transformation by Geometry Matrix

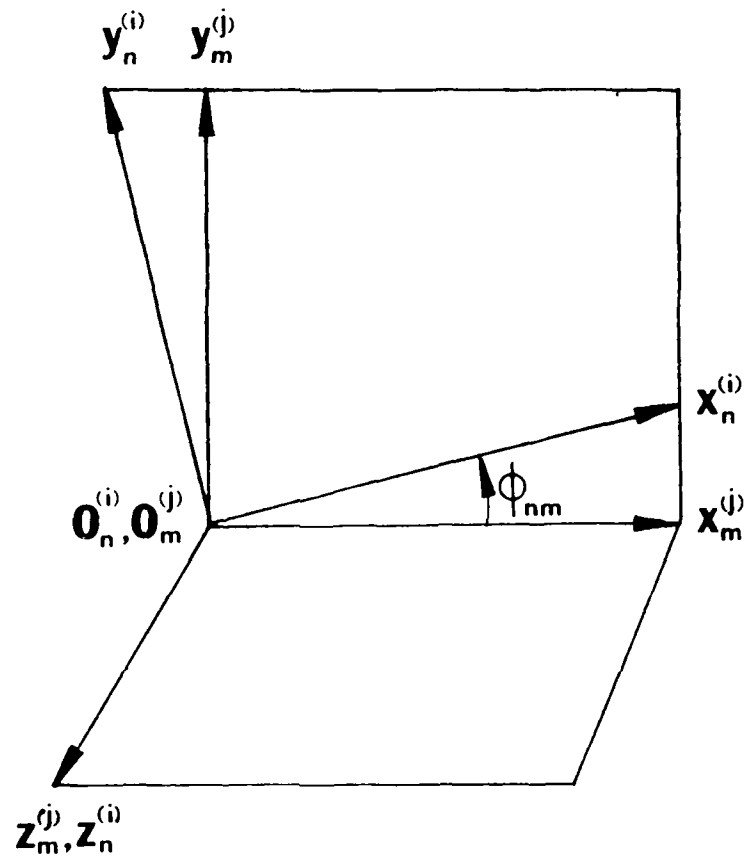
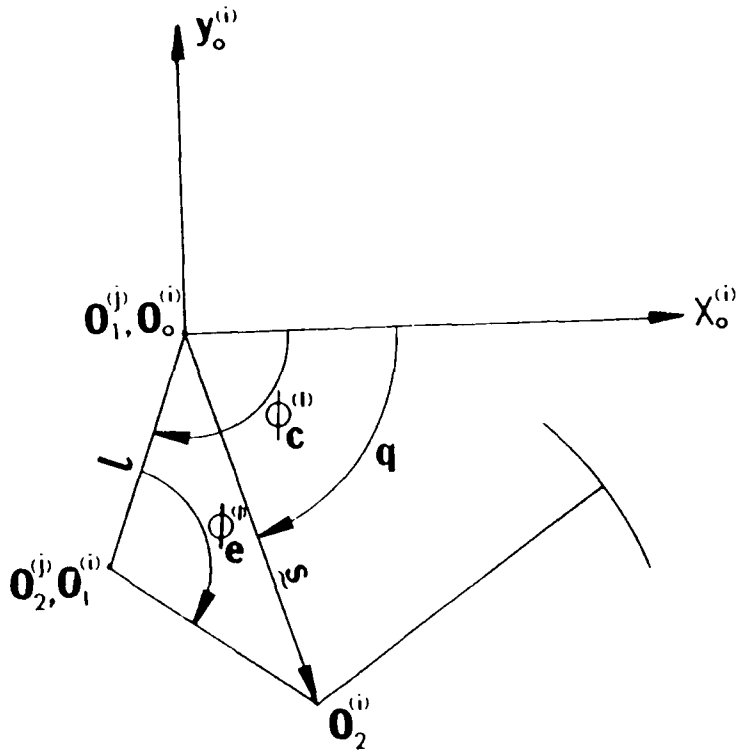

Fig.2.3

Coordinate Transformation by Rotation Matrix

(a)



(b)

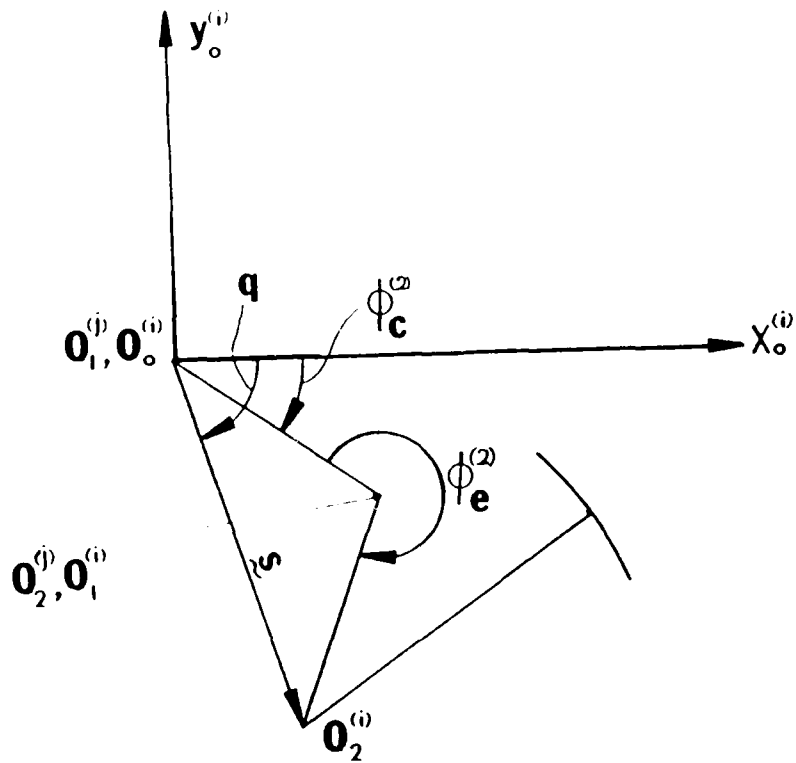
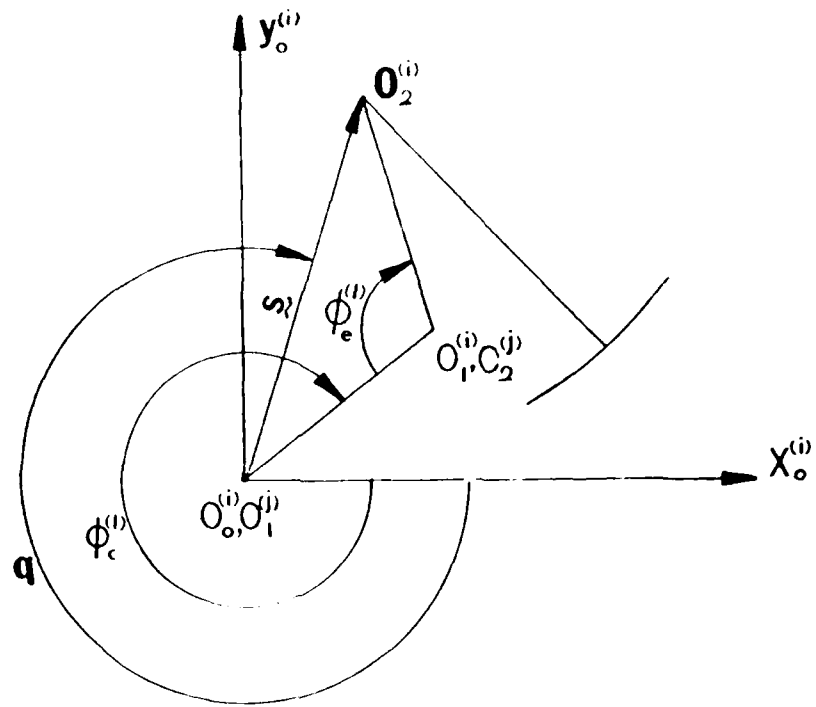

Fig. 3.1
Basic Settings for Left-Hand Pinion

(a)



(b)

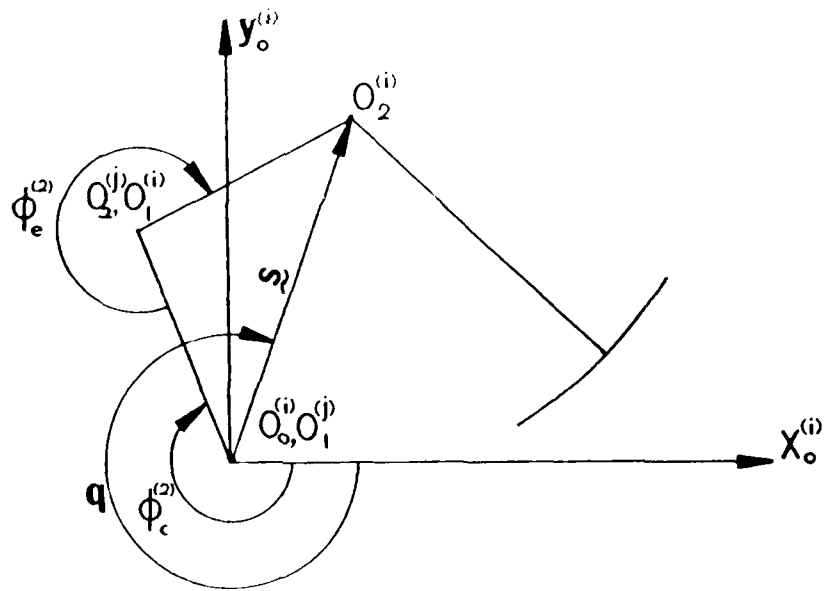

Fig. 3.2
Basic Settings for Right-Hand Pinion



Report Documentation Page

1 Report No NASA CR 182138 AVSCOM TR 88-C-016		2 Government Accession No <i>88-016</i>		3 Recipient's Catalog No.	
4 Title and Subtitle Determination of Settings of a Tilted Head-Cutter for Generation of Hypoid and Spiral Bevel Gears				5 Report Date June 1988	
7 Author(s) F.L. Litvin, Y. Zhang, M. Lundy, and C. Heine				6 Performing Organization Code	
9 Performing Organization Name and Address University of Illinois at Chicago P.O. Box 4345 Chicago, Illinois 60680				8 Performing Organization Report No. None	
12 Sponsoring Agency Name and Address Propulsion Directorate U.S. Army Aviation Research and Technology Activity AVSCOM Cleveland, Ohio 44135-3127 and NASA Lewis Research Center Cleveland, Ohio 44135-3191				10 Work Unit No. 1L162209AH76 505-63-51	
15 Supplementary Notes Project Manager, Robert F. Handschuh, Propulsion Directorate, U.S. Army Aviation Research and Technology Activity AVSCOM, Lewis Research Center. F.L. Litvin and Y. Zhang, University of Illinois at Chicago; M. Lundy and C. Heine, Dana Corporation, Fort Wayne, Indiana.				11 Contract or Grant No. NAG3-783	
16 Abstract Kinematics of Gleason mechanisms of hypoid and spiral bevel cutting machines is considered. These mechanisms are designated to install the position and tilt of the head cutter. The tilt of the head cutter with standard blades provides the required pressure angle. The authors have developed the matrix presentation of kinematics of these mechanisms, and basic equations for the required settings. An example is presented based on the developed computation procedure.				13 Type of Report and Period Covered Contractor Report Final	
17 Key Words (Suggested by Author(s)) Hypoid gears Spiral bevel gears Gear manufacture Gears				14 Sponsoring Agency Code	
18 Distribution Statement Unclassified - Unlimited Subject Category 37					
19 Security Classif. (of this report) Unclassified		20 Security Classif. (of this page) Unclassified		21. No of pages 26	22. Price* A03

END

DATE

9-88

DTIC