

UNCLASSIFIED

SECURITY CLASSIFICATION OF THIS PAGE (When Data Entered)

OTL FILE COPY

1

AD-A197 092

REPORT DOCUMENTATION PAGE

READ INSTRUCTIONS BEFORE COMPLETING FORM

1. REPORT NUMBER AFIT/CI/NR 88-151		2. GOVT ACCESSION NO.		3. RECIPIENT'S CATALOG NUMBER	
4. TITLE (and Subtitle) MANAGEMENT ANALYSIS AND SYSTEMS MODEL OF DEPARTMENT OF DEFENSE ACQUISITION STRUCTURE AND POLICY				5. TYPE OF REPORT & PERIOD COVERED PHD THESIS	
6. AUTHOR(s) GREGG MARSHALL BURGESS				6. PERFORMING ORG. REPORT NUMBER	
7. PERFORMING ORGANIZATION NAME AND ADDRESS AFIT STUDENT AT: FLORIDA STATE UNIVERSITY				8. CONTRACT OR GRANT NUMBER(s)	
10. PROGRAM ELEMENT, PROJECT, TASK AREA & WORK UNIT NUMBERS				11. CONTROLLING OFFICE NAME AND ADDRESS	
12. REPORT DATE 1988				13. NUMBER OF PAGES 375	
14. MONITORING AGENCY NAME & ADDRESS (if different from Controlling Office) AFIT/NR Wright-Patterson AFB OH 45433-6583				15. SECURITY CLASS. (of this report) UNCLASSIFIED	
15a. DECLASSIFICATION DOWNGRADING SCHEDULE				15. DISTRIBUTION STATEMENT (of this Report) DISTRIBUTED UNLIMITED: APPROVED FOR PUBLIC RELEASE	
17. DISTRIBUTION STATEMENT (of the abstract entered in Block 20, if different from Report) SAME AS REPORT				DTIC ELECTE S AUG 03 1988 D <i>CD</i>	
18. SUPPLEMENTARY NOTES Approved for Public Release: IAW AFR 190-1 LYNN E. WOLAVER Dean for Research and Professional Development Air Force Institute of Technology Wright-Patterson AFB OH 45433-6583					
19. KEY WORDS (Continue on reverse side if necessary and identify by block number)					
20. ABSTRACT (Continue on reverse side if necessary and identify by block number) ATTACHED					

THE FLORIDA STATE UNIVERSITY
COLLEGE OF BUSINESS

A MANAGEMENT ANALYSIS AND SYSTEMS MODEL
OF DEPARTMENT OF DEFENSE ACQUISITION
STRUCTURE AND POLICY

by

GREGG MARSHALL BURGESS

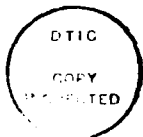

A Dissertation submitted to the
Department of Information and Management Sciences
in partial fulfillment of the
requirements for the degree of
Doctor of Philosophy

Accession	for	
1988	10/1	<input checked="" type="checkbox"/>
1988	10/3	<input type="checkbox"/>
1988	10/4	<input type="checkbox"/>
A-1		

Approved:

Thomas A. Clark, Jr.
Professor Directing Dissertation
John W. Ginn
William H. Ginn
Robert W. Ginn
John W. Ginn
John W. Ginn



Summer Semester, 1988

A MANAGEMENT ANALYSIS AND SYSTEMS MODEL
OF DEPARTMENT OF DEFENSE ACQUISITION
STRUCTURE AND POLICY

(Publication No.)

Gregg Marshall Burgess, Ph.D.
The Florida State University, 1988

Major Professor: Thomas Dillard Clark, Jr., DBA

This research reports the results of a policy modeling study in which a system dynamics simulation model of the United States weapon acquisition system was developed. The model integrates the impacts of the arms race, fiscal constraints, national budget priorities, the Department of Defense acquisition process, competing defense budget priorities, and the structure of the defense industrial base into a single model. The research presents the theoretical bases for the simulation model in the form of a graphical conceptual model. The conceptual model was developed after a review of the pertinent literature and in conjunction with interviews with senior analysts and executives representing the Congress, the executive branch, the Department of Defense, academia, and defense industry. The validation process for the simulation model and a demonstration of the policy evaluation capabilities of the model are presented.

ACKNOWLEDGMENT

First and foremost I would like to express my sincerest gratitude to Professor Thomas D. Clark, Jr. for his guidance, help and friendship. As my advisor, he provided me with sound counsel; as my chairman, he expertly guided me through the dense thicket of my dissertation; as my teacher, he provided me with the knowledge to succeed; and as a friend, he made the experience enjoyable. I am also extremely grateful to the members of my dissertation committee. They much of the credit for helping me make my research comprehensible. And last, but not least, I would like to thank Connie and Caitlin for providing me with the inspiration to finish up and move on to bigger and better things.

TABLE OF CONTENTS

LIST OF TABLES	vii
LIST OF FIGURES	viii
Chapter	
1. THE RESEARCH PROBLEM	1
Introduction	1
Problem Statement	4
Background and Justification for the Study	11
Acquisition System Structure	20
Research Methodology	29
Plan of Presentation	33
2. LITERATURE REVIEW	36
Introduction	36
Industry Sector	42
Defense Sector	52
National Sector	63
Threat Sector	66
Summary	69
3. RESEARCH METHODOLOGY	75
Introduction	75
Conceptualization	80
Formulation	86

Chapter		
	Testing	88
	Implementation	97
4.	CONCEPTUAL MODEL	99
	Introduction	99
	System Structure	102
	Threat Sector	105
	National Sector	114
	Defense Sector	120
	Industry Sector	131
	Summary	136
5.	PARAMETRIC MODEL	139
	Introduction	139
	Threat Sector	142
	National Sector	168
	Defense Sector	182
	Industry Sector	240
	Summary	255
6.	MODEL VALIDATION AND EXPERIMENTATION	257
	Introduction	257
	Tests of Model Structure	258
	Tests of Model Behavior	264

Chapter	
Tests of Policy Implications	276
Summary	279
Policy Experimentation	282
7. SUMMARY AND CONCLUSIONS	294
introduction	294
Literature	295
Modeling	298
Conceptual Model	300
Parametric Model	302
Future Research	306
Summary	308
APPENDIX	
A. THE INTERVIEW PROCESS	312
Introduction	312
Respondent Selection	315
First Round Interviews	318
Second Round Interviews	324
Model Evolution	329
Recommendations	342
B. DYNAMO CODE FOR PARAMETRIC MODEL	349
SELECTED BIBLIOGRAPHY	363

LIST OF TABLES

Table		Page
1.	Figure 28 Key	145
2.	Figure 45 Key	170
3.	Figure 53 Key	185
4.	Figure 65 Key	204
5.	Figure 80 Key	224
6.	Figure 90 Key	235
7.	Figure 94 Key	242
8.	<i>Parameter Verification Results</i>	261
9.	Model Behavior Sensitivity to Parameters	277
10.	Confidence Building Tests Results	281
11.	Summary of Conclusions by Category	310
12.	Interview Respondents	317
13.	Interview Schedule, August 1986	321
14.	Interview Schedule, March 1987	323
15.	Interview Schedule, September 1987	325
16.	Interview Schedule, March 1988	326
17.	Summary of Recommendations	347

LIST OF FIGURES

Figure		Page
1.	Overall System Structure	28
2.	The Research Process	34
3.	Weapon Acquisition Literature Summary	41
4.	Weapon Acquisition Literature Summary of Conclusions	74
5.	The Research Process Flow	76
6.	Example of Causal Mapping	84
7.	Example of a Negative Feedback Loop	85
8.	Forrester and Senge's (1980) Confidence Building Tests	89
9.	Weapon Acquisition System Structure	101
10.	Weapon Acquisition System Causal Map	106
11.	Threat Sector Basic Structure	107
12.	Global Tension Structure	109
13.	Threat Sector Complex Structure	113
14.	National Sector Basic Structure	115
15.	Spending and Investment Structure	116
16.	Savings and Money Supply and Demand Structure	117
17.	National Sector Complex Structure	119
18.	Defense Sector Basic Structure	122

Figure		Page
19.	Defense Spending Categories	123
20.	Research and Development Spending Structure	126
21.	Acquisition Spending Structure	127
22.	Operations and Maintenance/Personnel Spending Structure	129
23.	Defense Sector Complex Structure	130
24.	Industry Capacity and Investment Structure	132
25.	Industry Concentration and Competitiveness Structure	133
26.	Development, Production and Cost Structure	134
27.	Industry Sector Complex Structure	137
28.	Threat Sector Modified Flow Diagram	144
29.	Structure of Soviet Defense Share of GDP	146
30.	Structure of Soviet GDP Increase Rate	147
31.	Structure for Soviet Weapon Depletion Rate	150
32.	Structure of Soviet Weapon Inventory Spending Share	151
33.	Structure of Soviet Technology Spending Share	153
34.	Structure of Soviet Weapon Technology Depletion Rate	154
35.	Structure for Relative Intelligence Resolution Effect on Soviet Intelligence Spending	156
36.	Structure of Soviet Intelligence Resolution Depletion	157
37.	Structure of Soviet Intelligence Accuracy Amplitude	158
38.	Structure for Global Tension Effect on Soviet Capability Perceptions	160

Figure		Page
39.	Structure for Global Tension Effect on US Capability Perceptions	160
40.	Structure for Soviet Desired Tension Change	162
41.	Structure for US Desired Tension Rate of Change	163
42.	Structure for Soviets' Perceived Capability Differential Effect on Global Tension	164
43.	Structure for US Perceived Capability Differential Effect on Global Tension	165
44.	Structure of Combined Intelligence Accuracy Effect on Global Tension	167
45.	National Sector Modified Flow Diagram	169
46.	Structure for Interest Rate Effect on Propensity to Consume	171
47.	Structure for Deficit Effect on Social Spending	174
48.	Structure for Interest Rates Rate of Change	176
49.	Structure for Tax Rate Rate of Change	179
50.	Structure for Deficit Impact on Defense Spending	179
51.	Structure for the Impact of Global Tension on Defense Spending	180
52.	Structure for Impact of Perceived Military Capability Differential on Defense Spending	181
53.	Defense Sector Modified Flow Diagram: Weapon Inventory Structure	184
54.	Structure for Weapon Technology Multiplier	187
55.	Structure for Weapon Depletion Rate	188
56.	Structure for Training Effect on Weapon Depletion	189

Figure		Page
57.	Structure for Force Maintainability Effect on Weapon Depreciation Rate	190
58.	Structure for Weapon Acquisition Spending Share	191
59.	Structure for Weapon Technology Effect on Development Period	193
60.	Structure for Systems Availability Effect on System Development Cancellation Rate	195
61.	Structure for Desired Production Starts	197
62.	Structure for Weapon Technology Produced Effect on Development Cost	198
63.	Structure for the Effect of Unit Cost on Development Cost	199
64.	Structure for System Production Period Effect on Units Per System	202
65.	Defense Sector Modified Flow Diagram: Readiness Structure	203
66.	Structure of Personnel Quality Differential Effect on Readiness Change	206
67.	Structure for Force Maintainability Differential Effect on Readiness Change	207
68.	Structure for the Effect of Spares and Munitions Stock Differential on Readiness Change	208
69.	Structure for Level of Operations Effect on Spares and Munitions Depletion	209
70.	Structure of Spares and Munitions Differential Effect on Spares and Munitions Spending Share	211
71.	Structure for Global Tension Effect on Desired Spares and Munitions	212
72.	Structure for Spares and Munitions Effect on Maintainability	213

Figure		Page
73.	Structure for Personnel Quality Differential Effect on Maintainability	214
74.	Structure for Global Tension Effect on Desired Maintainability	215
75.	Structure for Personnel Spending Level Effect on Personnel Quality	217
76.	Structure for Personnel Quality Differential Effect on Personnel Spending Share	218
77.	Structure for Weapon Technology Effect on Desired Personnel Quality	219
78.	Structure for Weapon Inventory Size Effect on Desired Force Size	220
79.	Structure for Training Effect on Personnel Quality	222
80.	Defense Sector Modified Flow Diagram: Weapon Technology Structure	223
81.	Structure for Relative Weapon Technology Effect on Technological Rate of Change	226
82.	Structure for Perceived Weapon Inventory Ratio Effect on F&D Spending Share	227
83.	Structure for Weapon Technology Ratio Effect on Weapon Technology Depletion Rate	228
84.	Structure for Determining System Reliability Rate of Change (SYSR>.5)	229
85.	Structure for Determining System Reliability Rate of Change (SYSR<.5)	230
86.	Structure for Perceived Weapon Technology Ratio Effect on Desired Technology Produced	231
87.	Structure for Force Maintainability and Weapon Technology Effect on Lethality Spending Share	232
88.	Structure for Maintainability Differential Effect on Lethality Spending	233

Figure		Page
89.	Structure for Perceived Weapon Technology Ratio Effect on Lethality Spending	234
90.	Defense Sector Modified Flow Diagram: Intelligence Resolution Structure	235
91.	Structure for Perceived Intelligence Ratio Effect on Intelligence Spending	237
92.	Structure for Actual Intelligence Ratio Effect on Intelligence Depletion Rate	238
93.	Structure for Intelligence Resolution Ratio Effect on Intelligence Accuracy Amplifier	239
94.	Industry Sector Modified Flow Diagram	241
95.	Structure for Industry Capital Investment	244
96.	Structure for Government Capital Investment	245
97.	Structure for Perceived Risk	246
98.	Structure for Perceived Risk Effect on Industry Concentration	248
99.	Structure for Technology Produced Effect on Industry Concentration	249
100.	Structure for Systems in Production Impact on Industry Concentration	250
101.	Structure for Industry Concentration and Capacity Utilization Effect on Profit Markup	251
102.	Structure for Technology Produced Effect on Production Cost	252
103.	Structure for Production Technology Effect of Production Cost	253
104.	Structure for Capacity Utilized Effect on Production Cost	254
105.	Actual vs Model GNP (1960-1985)	265
106.	Actual vs Model Social Spending (1960-1985)	266
107.	Actual vs Model Defense Spending (1960-1985)	267
108.	Actual vs Model Soviet Defense Expenditures	268
109.	Comparison of Soviet and United States Model Generated Defense Expenditures	269

Figure		Page
110.	Defense Spending and Unit Cost	283
111.	Defense Spending Comparison	286
112.	Comparison of Federal Deficits	287
113.	Comparison of Production Rates	288
114.	Comparison of Systems in Production	289
115.	Comparison of System Production Periods	290
116.	Comparison of Units Produced Per System	291
117.	Comparison of Unit Cost	292
118.	The Research Process	313
119.	The Interview Process	314
120.	Version 1 of the Threat Sector Model	335
121.	Version 2 of the Threat Sector Model	337
122.	Version 3 of the Threat Sector Model	340
123.	Version 4 of the Threat Sector Model	341

CHAPTER 1

THE RESEARCH PROBLEM

Introduction

In the year 2054, the entire defense budget will purchase just one aircraft. This aircraft will have to be shared by the Air Force and Navy 3 1/2 days each per week except for leap year, when it will be made available to the Marines for the extra day (Augustine 1986, 143).

This somewhat facetious statement, based on extrapolation of aircraft unit costs and defense budgets, is one of Augustine's Laws that well illustrates the direction in which the United States is headed in terms of the weapons which it is buying and the decisions it must face.

That this outcome seems impossible is a virtual guarantee that it will be just that. What it means is that today's policies are unsustainable. They will be radically changed. The only question is how - whether in a political spasm or gradually, allowing those affected to plan ways of coping (Peterson 1987, 64).

The problem facing defense policy makers is how to bring about the reforms that are necessary in a manner that does not adversely impact the capability of the United States to defend itself and its global interests.

Since the 1960's there has been a continuous stream of government and independently sponsored research, using many perspectives and methods, into the problems of weapon acquisition reform. The research typically has been aimed at the Department of Defense and has involved a

combination of economic, quantitative, and subjective studies. The studies are actually all quite subjective in nature because none of the analyses directly imply that specific policy recommendations would be effective. The recommendations have all been based on a certain amount of intuitive analysis which is provided by experts with experience in the system.

The conclusions of these studies have provided competing policy alternatives that have been, in most cases, divergent. The result has been a cyclical pattern in policy reform. The policies of succeeding administrations tend to be resurrections of previous policies, such as prototyping, centralized decision making, decentralized implementation, concurrent production and development, and assorted contracting methods. During each administration, the impact on the unit cost of the weapons which are procured using these policies seems to be minimal, and so the policies are changed by following administrations. The number of policy alternatives which have been identified are limited and so each of the policies is recycled in its turn.

Policy-oriented models have been widely used in the government to aid in policy analyses and policy evaluations (Greenberger, Crenson and Crissey 1976). Large macroeconomic models are routinely used by Congressional budget staffs as well as the Office of Management and Budget. The Department of Defense is perhaps the biggest user of large-scale simulation models to aid in policy and decision making at all levels. However, no such models have been used to aid in the policy debates which continuously rage concerning the

widely held view that the United States has not been buying its weapons efficiently. The annual cost of this inefficiency in dollar terms is probably in the tens of billions of dollars if not higher (Fallows 1986, Stubbing 1986). Models such as the one reported in the Meadows' Limits to Growth (1972) have been able to attract significant public attention by their ability to infer some scientific method to public policy analysis (Greenberger et al. 1976). Given the size of the defense budgets and the seriousness of the consequences of not following a prudent policy, it is surprising that a policy model has not been presented in the public forum which is concerned with the public debate on defense acquisition.

According to Coulam (1977) a good understanding of the acquisition system is required to develop the kind of policies which would be effective in reforming the behavior of the system. Clark, Whittenberg and Woodruff (1985, 22) stated that the acquisition system is "large and complex, containing a myriad of interrelationships among its components. This complexity makes it difficult for a policy maker to visualize and understand the complete system." Policy models have been found to be effective tools in refining the intuition of policy makers (Greenberger et al. 1976). The educational role of policy models along with their ability to "provide a method of generating alternative answers given various structures and policies" (Clark et al. 1985, 43) make them well suited to an investigation of weapon acquisition reform.

Problem Statement

The problem addressed in this study has four facets. First, what is the nature of the decision process and information structure in what is labeled here as the defense acquisition system? Second, can a valid conceptual model be developed which provides a framework for policy discussions and further study? Third, can a valid computer-based policy evaluation model of the system be developed using the conceptual model as a basis? Fourth, can the usefulness of the models be demonstrated by testing representative policies for managing system behavior?

The objective of the study was to integrate the theoretical frameworks which have been used in defense acquisition policy studies into a single framework and then use it to develop a simulation model for studying long-term system behaviors. From this objective, certain research propositions and research questions were developed which governed the conduct of the study. The propositions are:

1. The causes of rapidly increasing unit costs, in real terms, for United States weapon systems can be effectively modeled conceptually based on the interactions between threat influences, national policies and fiscal constraints, defense acquisition policies, and the structure and policies of the defense industry (Chapter 4).
2. The complex interrelationships among the variables in the acquisition system can be effectively represented in a conceptual model which highlights

pairwise interactions and identifies information feedback structures (Chapter 4).

3. The complex interrelationships among the variables in the acquisition system can be effectively modeled parametrically as a system of difference equations (Chapter 5).

4. The influence of the threat on the weapon acquisition system can be effectively modeled by using the relationships between Soviet and American military capabilities, political objectives and domestic fiscal constraints (Chapters 4 and 5).

5. The influence of the national political agenda and the inherent fiscal constraints on the weapon acquisition system can be effectively modeled using a macroeconomic system which relates GNP, revenues, consumption, investment, budget levels, the budget deficit, the national debt, and defense and social budget levels (Chapters 4 and 5).

6. Policy experimentation using the parametric model can demonstrate effectively that policies implemented at the national and Defense Department level might result in effective weapon acquisition reform (Chapter 6).

Because the objective of the study was to develop a conceptual framework and policy model, the research questions are not stated in the null-alternative hypothesis format, but rather as broad foundations that provided direction for the research. The research questions provided a reference point for the conceptual and simulation models, and were based on problem

behaviors associated with the acquisition system and policy alternatives which deal with those behaviors.

Policies such as those supported by the Packard Commission Report (President 1986) and the "Carlucci initiatives" (Carlucci 1981) will continue to be ineffective even if they were totally implemented because they are too limited in scope and do not make any attempt at correcting structural deficiencies in the system (Goldwater 1987, Marsh 1986a, Ulsamer 1986). Policies which will result in structural changes will require unprecedented peace-time cooperation between the Congress and the Department of Defense; however, the cooperation will be necessary to avoid a crisis due to the problem of rising weapon costs (Kirkpatrick and Pugh 1985).

Most analyses and studies of the defense acquisition process have not concentrated on the long term problem of rising unit cost of weapon systems but rather on specific contributing causes of rising costs. The economic studies reviewed in Chapter 2 (Gansler 1980, Baldwin 1967, Peck and Scherer 1962, Fox 1974, Weida and Gertcher 1987) tend to focus on the economic inefficiencies in defense industries. These studies assume a priori that more efficient production and allocation could by itself curb the rising cost of the weapons. This view supposes that, like consumer electronics production, if resources are allocated efficiently, product performance can be increased simultaneously as production costs are lowered (Gansler 1980). These studies have ignored the possibility that the desire to produce weapons which push the

bounds of state of the art technology is a matter of policy which consciously limits the possibility of efficient production. The tradeoff relationship between weapon technology and production costs has been well established (Dews 1979, Gansler 1980, Perry 1971). There is no evidence, however, that the United States military and defense policy makers are willing to modify the specifications for weapon system performance in order to benefit from lower production costs which could result in larger weapon buys.

Many of the other studies cited in Chapter 2 analyze the role of specific policies and their effect upon weapon system procurement efficiency. These policies include: competition in development and production (Archibald 1981, Bickner 1964, Rich 1976), *prototyping* (Lee 1983, Perry 1971, Smith 1981), contractor profitability (Profit '76, DFAIR 1985), austere development (Lee 1983, Perry 1971, Rich 1986), multiyear budgeting (President 1986, Carlucci 1981), dual source production (Beltramo 1983, Gansler and Kratz 1986), and improved cost and schedule estimation (Baseman 1984, Bickner 1964, Rich 1986). These policies have been identified for many years and have been implemented at least in some limited fashion (Dews 1979). The impact of the policies on the cost of the weapons which are purchased has been minimal (Dews 1979, Stubbing 1986), although many of the proponents of these policies would undoubtedly argue that they were not fully implemented.

This research and the resulting conceptual and simulation models focus on the rising unit cost of major weapon systems and the determinants of this

behavior. System behaviors which have been thought to contribute to the problem of rising weapon costs were examined. These behaviors include: low levels of capital investment by defense contractors (Barker and Konwin 1982, Gansler 1980), over-capacity at the prime contractor level (Gansler 1980), under-capacity at the sub-contractor levels (Gansler 1980), lengthening production and development periods (Rich 1986, Smith 1980), fluctuating readiness levels (Fallows 1981, Luttwak 1984), and real increases in defense spending being used to increase to unsustainable levels the number of weapon systems in production (Fallows 1986, Clark et al. 1985).

The simulation model which is a product of this research can be used to determine the long-term impact of current and previous policies on these system behaviors. In addition, the model can be modified to specifically assess the following research issues: 1) What impact does a reduction of the number of weapon systems in production and development in a given year have on resources allocated to the remaining systems, on development and production schedules, and on unit costs? 2) Will a reduction in government provided plants and equipment result in higher levels of industry capital investment, as a consequence of reduced industry capacity, and more efficient means of weapon production? 3) Would a policy of limiting the number of new weapon developments and production starts in periods of rising defense spending result in more efficient use of defense funds in the long-run?

The first research question was initially tested by Clark, Whittenberg and

Woodruff (1985) using a more simplistic model than the one developed here. The second research question is a direct result of Gansler (1980) who claimed that an overcapacity exists at the prime contractor level within the defense industry and that this causes a reluctance for firms to invest in new and efficient production capital. The third research question is an attempt to deal with the problems resulting from the defense buildup which occurred between 1978 and 1984 (Fallows 1986). Fallows (1986) noted that spending increases were used to fund the development of new weapons whose production and operation would be unsustainable in the outyears, instead of being used to purchase additional weapons already in production or to fund current readiness accounts, such as spare parts, munitions and training.

The effectiveness of these and other policies can be evaluated based upon model outputs concerning the problem system behaviors as noted. Unit weapon cost (\$ per unit), industry capital investment (\$ per year), industry capacity (units per year) and capacity utilization (% of total capacity utilized), number of weapon systems in development, number of weapon systems in production, number of units per weapon system produced, readiness level (\$), intelligence resolution (\$), weapon technology level (\$), and weapon inventory level (\$) can all be tracked across time to determine the impact of these policies on system behavior.

To address these kinds of problems, a specific research methodology involving an iterative process of conceptualization, analysis and measurement,

and modeling generally referred to as the systems science paradigm (Schoderbek et al 1984) was followed resulting in the simulation model which is presented in Chapter 5. Each iteration of the paradigm resulted in an increased level of confidence in the conceptual model presented in Chapter 4 and the simulation model presented in Chapter 5.

As a first step a broad-based conceptual structure using information available in the literature was developed. An initial version of the conceptual model was developed at the same time. Then, participants at various executive levels representing a cross section of the acquisition system were interviewed. A complete list of those interviewed is presented in appendix A. These interviews were used to evaluate the conceptual structure and the initial conceptual model. The third step was the revision of the conceptual structure and conceptual model. At this point the structure of the model based on four interacting sectors was largely confirmed. The resulting conceptual model is presented in Chapter 4.

The fourth step was to present an explicit statement of the conceptual structure and conceptual model to the same executives for review. This round of talks was directed at evaluating, verifying and validating the conceptual structures. The fifth step involved mathematically modeling the four sectors. Each sector was tested and integrated into a single parametric model. The simulation model is presented in detail in Chapter 5. Confidence building tests suggested by Senge and Forrester (Forrester and Senge 1980) were

performed. These tests are described in detail in Chapter 3 and the results of the tests are presented in Chapter 6. The last step was to perform a sample policy experiment in order to demonstrate the usefulness of the parametric model and further validate its conceptual basis. In the remainder of this chapter a more specific discussion of the research methodology is provided along with an overview and description of the acquisition system.

Background and Justification for the Study

Since the 1950's there has been a nearly continuous call for far-reaching reforms in the way that the United States defense establishment develops, produces and contracts for major weapon systems (Coulam 1977, Stubbing 1986). The basis for this pressure to reform comes from the public's perception of wasteful defense spending, the rapidly rising costs of the weapons which are procured, and a shrinking piece of the GNP being allocated to defense, due mainly to an unwillingness to fund larger defense budgets at the expense of expanding social programs (Weida and Gertcher 1987). Contributing to the public's perception that the defense industrial complex is unable to efficiently allocate defense resources are the well publicized instances of spare parts overpricing, weapon program cost overruns and delays, and the operational deficiencies of some of the weapon systems which are procured (Rich et al 1986). The failings of the defense industrial complex as illustrated by any specific weapon purchase are debatable as both

proponents and opponents of the system have exaggerated the issues in their defense or condemnation of the system. There does seem to be a consensus that the weapons which are procured could be had at a much lower cost, but disagreement comes when the cause for the increased costs is assigned. Basically there are three groups which have been blamed for the inefficiencies in defense weapons acquisition: the defense industry, the Department of Defense and the armed services, and the Congress.

Defense industries have been blamed for exacting unreasonable profits (DFAIR 1985, Profit '76 1976) and have been widely accused of fraud (Schnever 1987). The Department of Defense has been accused of bureaucratic inefficiency (Fallows 1981, Luttwak 1984) and pursuing wasteful practices as a matter of policy (Fitzgerald 1972, Rasor 1985). The Congress is maligned because of the institutionalization of "pork-barrel" politics and its tendency to micromanage (Fallows 1981, Stubbing 1986, Weida and Gertcher 1987). What has been missing in the policy debates is a capability to determine the causes of the system's behaviors, such as rising weapon costs, and a means of evaluating policy alternatives. This research was accomplished in order to develop a systemic framework and model which emphasize causality, structure, and a long-term outlook to provide just this capability.

A systems perspective was essential because the wide ranging elements involved in weapon system acquisition are all very much interrelated. Previous studies have taken a more analytical perspective, dealing with a

single element or relationship. However "one must be very, very careful, therefore, that in the process of isolating the system for study, one does not ignore or cut out the essential interrelationships existing among the various components" (Schoderbek et al. 1985, 7). Previous works have studied contracting procedures (Peck and Scherer 1962, Scherer 1964, Fox 1974), industry structure and behavior (Baldwin 1967, Gansler 1980), the acquisition process (Defense Science Board 1978, Dews 1979, Fox 1974, President 1970, President 1986, Rich et al. 1986), and industry profitability and capital investment behavior (DFAIR 1985, PAYOFF '80 1980, PROFIT '76 1976) and have emphasized a relatively micro-analytical approach.

This research developed a systems framework model and a simulation model which together provide an explicit description of the system, provide a reference point for policy debate, and provide a means for evaluating alternative policies. Policy models are able to focus on causality within a systems framework and have been shown to be effective in combining elements of the scientific method with policy making (Greenberger et al. 1976).

Policy models can perhaps best be categorized by the kind of information that they generate and how it is used (Greenberger et al. 1976). The kinds of information produced by policy models include: unconditional forecasts, conditional forecasts, and educational information (Greenberger et al. 1976). Unconditional forecasting models are perhaps the most frequently mentioned type of model and are used as a technique for generating

predictions about circumstances that policy-makers may face. Econometric models fall in this category. Conditional forecasting models attempt to deal with the consequences of policy decisions by making predictions contingent on the actions of the policy-makers. Policy alternatives may be evaluated in this way by estimating the impact of each policy and predicting the consequences. Unlike the optimization models associated with operations research, conditional and unconditional forecasting models do not prescribe a "best" course of action for the decision maker. The models are used to supply information to aid in the decision making process. This is the type of model which has resulted from this research.

Policy models also generate information which is best suited to an educational role, that is "to refine the intuition of policymakers" (Greenberger et al. 1976, 25). This is perhaps the greatest contribution of these models to the decision making process. Explicit models invite criticism and examination and are effective at providing a structure for debate (Greenberger et al. 1976). A structure for debate or frame of reference is exactly what has been missing in the debates concerning defense acquisition. The first model presented in this research provides such a conceptual structure. The conceptual model detailed in Chapter 4 incorporates the views of many senior executives and politicians who have participated in the acquisition process. It provides an explicit systemic representation of the acquisition process which stresses causal relationships and provides the framework for a parametric model which

provides greater detail and the possibility of policy evaluation or analysis.

The models address the question of how Congressional, Department of Defense and industry structures and policies impact the cost of the weapons which are procured. The models do not focus on the size of the defense budget or the waste and abuse issue, but rather on rising weapon costs. The size of the defense budget in any given year is impacted by world events and political policy more than by military requirements which are hard to assess (Stockman 1986, Weida and Gertcher 1987). Many see the waste, fraud and abuse issue as a "political attention getter" rather than a substantive defense management issue (Correll 1984, Gileece 1985). The well publicized cases of overpriced hammers and coffeemakers are used for their political value with the public, and do not in and of themselves indicate a system run amok (Stockman 1986).

The determinants of weapon unit costs cited in the literature are: unchanging weapon system performance specifications, production technology used, number of weapons produced, length of production time, contractor profits, weapon technology, and development period (Clark et al. 1985, Coulam 1977, Dews et al 1979, Fallows 1981, Fox 1974, Gansler 1980, PAYOFF '80 1980, PROFIT '76 1976, Rich et al. 1986, Stubbing 1986). Each of these factors are impacted in some way by the structures and policies which are pursued by the defense industry, the Congress and the Department of Defense. The studies cited have investigated one or more influences independently within an industry or Department of Defense setting. None of these studies has

developed a framework which is capable of determining how these influences interact.

Of the many studies of the weapon acquisition system which have been completed over the past thirty years or so, only three have proposed a systemic representation using an explicit model (Barker and Konwin 1982, Clark et al. 1985, Sapp 1971). The most common method of study has been to apply intuition and experience to develop arguments in support of certain policies (Fallows 1981, Fitzgerald 1972, Luttwak 1984, President 1970, Rasor 1985, Stubbing 1986). Studies such as the Packard Commission's (President 1986), the Defense Science Board's (1978), Profit '76 (1976), and DFAIR (1985) characterize a kind of hybrid study which uses some quantitative analysis to support conclusions which are based on intuition and the lessons of experience. This reliance on intuition more than sound quantitative analysis is evidenced by the divergent conclusions which are reached by successive studies using the same data. Of the many government sponsored commissions which have studied the defense acquisition problem, perhaps the so called Packard Commission (President 1986) has been the most successful at generating Congressional backing. This is probably due more to the political circumstances of the day than anything, but it is not clear how the policies which have been passed into law (Goldwater-Nichols DoD reorganization act of 1986) will impact the behavior of the system.

The most analytical studies of the defense acquisition system have

utilized economic theories. Peck and Scherer's The Weapons Acquisition Process: An Economic Analysis (1962) and Scherer's The Weapons Acquisition Process: Economic Incentives (1964) were perhaps the first really influential studies, that coincided with the beginning of a decade of reform in defense acquisition management (Fox 1974). These two studies, based on case studies of twelve defense programs and seven highly technical commercial programs, concentrated on the procurement practices and regulations, and compared the behavior and performance of the contractors. Fox's Arming America (1974) was billed as a follow-on study to the Peck and Scherer study (1962). Fox found that the decision makers appeared to be making the same mistakes in the 1970's as they did in the 1950's and 1960's. Gansler's The Defense Industry (1980) is the most recent in this line of basically economic studies of the weapon acquisition system. The Gansler book bases specific policy recommendations on empirical analyses, however the causal relationships which he hypothesizes are limited by the paradigms which he has chosen. While these studies seem to be the most often cited studies, their influence does not seem to have been able to result in a consensus concerning weapon acquisition reform. The macroeconomic and industrial organization paradigms are unable to explicitly account for the interaction of all the pertinent factors which these authors have identified.

"Causal order is a substantive or empirical problem to be solved by our knowledge about how the real world works, not by statistical gyrations" (Davis

1985, 3). If the continual criticism of the system's behavior is justified, the economic arguments of Peck, Scherer, Fox and Gansler apparently have not been effective in providing a framework with the requisite variety (Beer 1967) required for understanding policy initiatives for defense acquisition management. Perhaps what is needed is a more systemic framework which can incorporate the contributions of multiple paradigms (Churchman 1968). The development of a causal model based on the views of participants in the system as well as those offered in the vast collection of literature available on the subject certainly seems to be what is needed and an approach not previously taken. An advantage of such a model is that it allows an open discussion of the explicitly stated assumptions that form its basis. This method of scientific research is closely aligned with Popper's refutationism (Bell and Bell 1980). Refutationists view knowledge as a set of

conjectures from which expectations can be deduced for empirical testing. Although scientists wishing to establish a theory hope the tests will be passed, a crucial quality of scientific conjectures is that they be refutable, or vulnerable to empirical error. If the conjectures pass empirical tests, they are corroborated; if not, they are falsified. In either case progress is made (Bell and Bell 1980, 15).

"A model is an experimental means of putting the theory into contact with the real world" (Harris 1968, 116). Also lacking in these previous studies was a way to test the policies which were recommended. The acquisition system is one which seemingly provides everyone who has experienced it first hand a different personal conceptual model about its behavior (Baseman 1984,

Fitzgerald 1972, Fox 1974, Gileece 1985, Marsh 1986a, Stubbing 1986). There have been a few attempts at developing such a model (Barker and Konwin 1982, Clark et al. 1985, Sapp 1971). None of the studies, however, have received much notoriety and none really deal with a true macro systemic structure.

The last type of approach to analysis found in the literature can be termed "subjective study". Included in these works are studies such as Fallows' (1981) National Defense which was based on extensive interviews, Luttwak's (1984) The Pentagon and the Art of War, and Stubbing's (1986) The Defense Game, which was based on the author's experiences as a career civil servant in the *Office of Management and Budget*. These three studies are interesting because of the broad view that they have taken, but are really compendiums of various personal perspectives about the system's behavior. Other subjective studies which appear in the popular press more typically take a rather narrow view of the system and the causes of the problems therein (Fitzgerald 1972, Rasor 1985).

In summary the problem of weapon acquisition is truly systemic in nature. As noted the studies mentioned have all taken a more limited view of the "acquisition system" than is presented in this research. This research studied the problems of weapon acquisition management with the aid of a macro-level model of the system using a methodology which allowed the inclusion of a wide variety of perspectives which are represented in the

literature. The development of a model allowed for the system structure to be explicitly stated and debated and for empirical validation of the theories inherent in the model. The model stresses causality and therefore is useful as a policy analysis as well as an educational tool to "refine the intuitions of policymakers" (Greenberger et al. 1976).

Acquisition System Structure

The reason behind the United States' tendency to procure increasingly costly weapons (Augustine 1986, Gansler 1980, Fallows 1981) is, in large part, the strategy which has been used for developing weapons since the second world war. During World War II, the United States produced relatively low technology weapons in vast quantities, technological advances tended to be incremental and the weapons were prototyped and tested prior to production (Coulam 1977). Following the war, the United States tended more and more to push the state of the art in weapons technology, with the result being weapons which are significantly more expensive in real terms and which take much longer to develop and produce (Gansler 1980). For example, in constant dollars, the 1960 F-4 fighter aircraft cost \$3.5 million while the 1975 F-15 fighter cost more than \$12 million (Gansler 1980, 16). A similar comparison of the World War II vintage British Spitfire aircraft with its modern day replacement, the Tornado, shows a remarkable 17,200% increase in constant dollar terms (Dyer 1985, 191). One result of the rapid rise in the cost of modern weapons is that

no nation, not even the richest, is able to afford to equip mass armies with the latest weapons as was done during the second world war and before (Dyer 1985, 191). In addition, rapid advances in technology create weapons which are extraordinarily lethal. The combination of extremely lethal and extremely expensive weapons results in smaller numbers of weapons available for combat and means that any future engagements will probably be very intense and very short, as both sides will be unable to produce enough weapons to keep up with losses. For example, in 1973, the Israelis and their opponents lost about fifty percent of their equipment in less than three weeks of combat (Dyer 1985, 192). Without advanced warning, conventional war can be *expected to be what is essentially a "come as you are" affair. This will preclude the United States from utilizing its superior industrial capacity, and puts a premium on defense readiness (Dyer 1985).*

This change in the way that the United States develops its weapons has been mirrored throughout the world, including the Soviet Union, even some less developed countries are buying the best weapons available (Dyer 1985). Within the United States, this behavior has been reinforced by the coalition which has been formed between the defense industry and its customers, the armed services. The defense industry has obvious reasons for wanting continuously to produce new and better weapons to replace existing ones, for that is, after all, how the firms make a profit. The individual services also have incentives to procure these weapons as they compete amongst themselves for

a share of the national security role and the resources that go with it (Luttwak 1984, Fallows 1981, Dyer 1985). Because the defense industry is a powerful and effective lobbying force representing a rather large and influential constituency, it can exert considerable political pressure to achieve desired ends (Stubbing 1986). The services are able to reinforce the political pressure by focusing attention on the perceived threats to national security (Dyer 1985). The services' behavior is reinforced by a system which bases promotion for individual officers on their ability to successfully defend their own service's interests and in acquiring new weapons, defining roles for them, and managing the enormous amounts of resources involved (Luttwak 1984, Dyer 1985).

Whatever the causes, the net result is that United States weapon acquisition policy has changed from large buys of relatively low cost, low technology weapons to small buys of high cost, high technology, highly lethal weapons which require long development periods and long production times. In some respects, the trend is self magnifying, in that any weapons procured in smaller quantities will cost more because industry overhead costs must be spread over smaller production runs (Coulam 1977, Perry 1979). The rapid increase in weapon technology and weapon costs has not coincided with real increases in defense spending, which tended to be flat through the 1950's, 1960's and 1970's (Fallows 1981, Gansler 1980). As long as acquisition funding stays at a nearly constant level and the United States continues buying more expensive weapons, longer and cheaper production runs may be

impossible due to fiscal constraints. One hope for breaking this cycle of spiraling weapons costs is that production efficiencies would enable the United States to produce the weapons more cheaply and high technology components would become less expensive as they have, for example, in consumer electronics (Gansler 1980). This has not occurred, largely due to the impact of the ever increasing sophistication of weapons technology which has been designed into the weapons produced. The requirements and design process which leads to design specifications is accomplished early and design specifications are not changed. This leads to a situation where performance tradeoffs cannot be made based on economic arguments. Weapons design *continually has tried to stay on the leading edge of technology advances* (Gansler 1980, Fallows 1981, Luttwak 1984). Production efficiencies depend, to a great degree, on the learning curve phenomena, large production runs, and relatively stable product and production technologies (Gansler 1980). To some degree the learning curve phenomena has been taken advantage of, although the effects have been mitigated by the shorter production runs and design instabilities of the weapon systems (Coulam 1977, Gansler 1980, Augustine 1985).

A second factor, which mitigates a lower production cost offsetting any increases due to technology improvements in the weapons, is that historically the defense manufacturers have been heavily dependent on government owned plants and equipment, especially in the aerospace industry (Gansler

1980). The impact of this dependence is that production is not accomplished using state of the art production methods, but more often using older and less efficient plants and equipment (Gansler 1980, Coulam 1977).

As noted in the last section, the history of studies, both government and private sponsored ones, dealing with the topic of weapon acquisition reform is quite long, and they generally support the conclusion that basic reform of the acquisition system has not been implemented effectively. In the 1960's concurrency of production and development was implemented to reduce the time of weapons development and to forego the expense of prototyping (fly before buy) (Coulam 1977, Stubbing 1986). The current problems of the B-1B strategic bomber procurement show the difficulty of managing concurrent acquisition with highly sophisticated weapons (Moore 1987). Also in the 1960's, Secretary of Defense McNamara tried to implement joint purchases for common requirements, with the most visible examples the Navy and Air Force purchase of the F-4, A-7 and F-111 aircraft. Extensive modification of these aircraft to serve particular needs of each service made this an expensive strategy. Secretary McNamara also introduced total package procurement and fixed price contracts to reduce cost growth, a centralized decision making and budgeting process (PPBS) and created a strong systems analysis group within the Department of Defense (Stubbing 1986, Clark et al. 1985). Fixed price contracts have created significant problems for some manufacturers and nearly sent the Lockheed aircraft company into bankruptcy. In the 1970's, Deputy

Secretary of Defense Packard implemented the Defense System Acquisition Review Council process which reduced concurrency pressures and reliance on fixed price contracts, and decentralized the responsibility and authority for acquisition management (Stubbing 1986, Clark et al. 1985). In the 1980's, beginning with the "Carlucci initiatives" and continuing with the implementation of many of the Packard Commission's recommendations, the emphasis has been on staged decision making, the budgeting process, incentive contracting, and the perception of a lack of competition in the defense industry (Stubbing 1986, Clark et al 1986).

Because the defense acquisition system is not an easy one to pin down, *previous studies have narrowed the concept of this system to either a study of the industry (Baldwin 1967, Gansler 1980), a study of the Defense Department acquisition process (Peck and Scherer 1962, Scherer 1964, Fox 1974, Clark et al. 1985, Coulam 1977, President 1970, President 1986) or a study of the impact of weapons acquisition policies on the national defense (Weida and Gertcher 1987, President 1986, Fallows 1981, Stubbing 1986).* The model presented here is a macro one which integrates the effects of threats to national security and global pressures; the setting of a national agenda and priorities; the weapon development, contracting and production processes; and the interaction of United States military capabilities with the threat. The model is represented as a system of four interacting subsystems or sectors. The industry sector embodies the structure and production characteristics of the defense

industry in terms of industry capacity, capital investment, production cost structure and determines the unit cost of the weapon mix which is determined in the defense sector. The defense sector transforms the resources which are allocated to it in the federal budget process into military capability. Military capability is composed of four dimensions: readiness, weapon inventory, weapon technology, and intelligence resolution. The national sector embodies the federal budgeting process and interactions between the federal budget and the United States' macroeconomic system. This sector places a fiscal constraint on the acquisition of military capabilities as a result of trading off social spending pressures, defense spending pressures and fiscal pressures. *The threat sector determines the demand for military capabilities resulting from the interaction of the United States' and Soviets' political agendas. A representation of the system structure, and the actors within the system, is shown in Figure 1.*

The military threat, which to a large degree is used to justify United States defense expenditures, is posed by the Soviet military or its surrogates (Luttwak 1984). Even in parts of the world where the United States would not expect to face Soviet troops, the probability is high that American troops would face Soviet trained and equipped troops (Dyer 1985). For this reason, as well as a desire to develop a parsimonious model, the threat sector represents primarily a Soviet influence. The real concern is not whether the Soviets are the only threat that is faced because they are not, but whether it is the Soviet

threat to which the acquisition system primarily reacts. The relationships in the threat sector are patterned after those in a threat sector of a model of the arms transfer process (Clark 1986). The interaction of the threat sector with the rest of the system is primarily through the pressure for defense expenditures in general, and increased pressure for specific defense expenditures depending on Soviet advances in readiness, technology or force levels.

The national budgeting sector also is represented using a relatively parsimonious strategy (Hall 1983, Stenberg 1980) based largely on classical macroeconomic theories. This sector will incorporate GNP, interest rates, consumption, investment, and three components of the federal budget: defense expenditures, social spending and debt service. Interaction with the rest of the system will occur through the pressure for defense spending and the defense spending variables. The national sector has been included because of the fiscal restraints that it will apply to the system, and because of the impact that fluctuating defense budgets have on the Department of Defense ability to efficiently procure weapons.

The defense sector is centered around the defense budget and is included to represent specific military capabilities that result from defense spending. The defense budget like the larger federal budget is decomposed into four components: personnel, operations and maintenance (O&M/P); acquisition; research and development (R&D); and intelligence resolution. Tightly linked to the defense budgeting process is the defense procurement

process. The defense sector is closely linked to the industrial sector through the variables which make up the procurement process. The procurement process is represented by the relationships between R&D and acquisition spending and the resulting technologies which are developed, the number of systems which are developed and produced, the number of units of each system which are produced, and the development and production periods.

The final sector, the industrial sector is included to reflect the relationships between industry structures and policies and defense sector outputs. Industry structure is represented by industry concentration, industry capacity, industry profitability and industry production costs. Industry policies include capital investment, bidding and pricing. The defense sector outputs and policies that impact the industrial sector include technology produced, units produced, systems produced, industry subsidies, foreign military sales and the provision of government owned capital. The defense and industrial sectors were at the heart of this systemic model and required a greater level of detail than the other sectors.

Research Methodology

The development of the simulation model which is a product of this research was a coordinated, iterative process. The system science paradigm (Schoderbek et al. 1984) calls for the development of a conceptual model as the first step toward the development of a parametric simulation model. This

paradigm proposes an iterative process of conceptualization, analysis and measurement, and modeling.

The objective of this study, as stated in the problem statement, was to develop an integrative systems framework and simulation model of the defense acquisition system. The first step in the process was a preliminary review of the literature. The literature review served multiple purposes. The review further defined the research objective and research problems, provided the initial basis for a conceptual framework with which to study the system, and provided the basis for developing an interview guide which was used in the next step of the process. The second step was to perform preliminary interviews with executives and others who were closely involved in the system to refine the conceptual framework, to refine the objective of the study and to determine the kind of literature which was most helpful in gaining a more detailed view of the system.

The third step in the modeling process was to combine the information gathered in interviews and literature review and use it in developing the initial conceptual model. A commonly used method for dealing with complex system structures while focusing on important interactions and relationships within the system is causal analysis or influence diagramming (Coyle 1977, Richardson and Pugh 1981). Using this technique required that the single interaction between each pair of interacting variables was considered in turn, and a causal relationship hypothesized. The difficulty in proposing such relationships was

not in formulating individual relationships or hypothesizing the direction of the influence, but in measuring its magnitude and dimension and in validating the existence of the relationships (Clark 1987). Many of the relationships identified in policy models are commonly held views, while other relationships can be supported with citations from the literature or from the interviews. Both types are important and produce different kinds of validity problems. The approach taken for validation of the models developed in this research is described in Chapter 3.

The development of the initial conceptual model was followed by further interviews and literature review in order to validate the concepts which were modeled. It is the nature of this kind of conceptual model that the validation process is accomplished primarily by assessing the reaction of "experts" to the model. The result of these validation interviews was a further refinement of the conceptual model. The next step in the modeling process was to develop a parametric model which corresponds to the conceptual model already developed. The parametric model required a modeling technique which could incorporate quantitative as well as qualitative relationships, and which was capable of effectively representing a complex decision/information structure. The system dynamics approach has been shown to be an effective modeling technique for this kind of application. It is able to focus on the structure of the acquisition system and emphasize the importance of complex feedback mechanisms that exist (Clark et al 1985, Richardson and Pugh 1981). The

approach required that any assumptions concerning the system's structure or behavior be explicitly stated in such a way that facilitates empirical or intuitive challenges. This characteristic placed the approach in the "refutationist" vein of scientific inquiry (Hall 1983). Forrester (1961) and Richardson and Pugh (1981) found that submitting the model to this critical process helps to create a more useful product for decision makers.

Just as with the conceptual modeling, the comments and criticisms of those interviewed were incorporated into the parametric model. Further interviews, further literature review and data collection and testing was the basis for the validation of the parametric model. Model validation was *conducted in accordance with the procedures outlined in "Tests for Building Confidence in System Dynamics Models"* (Forrester and Senge 1980). These tests include tests of model structure, model behavior and policy implications of the model. The results of the model validation process resulted in changes to the parametric model and a fuller understanding of its capabilities and uses.

The last step in the modeling process was the policy experimentation phase. During this phase, a policy experiment was conducted to demonstrate how the simulation model might be used in an actual policy analysis setting. This phase resulted in a fuller understanding of the system structure and behavior, and provided insights into potential policy alternatives. Following the development and validation of the conceptual and parametric models, and policy experimentation, the research objective was reviewed and ideas for

additional research into this area were developed. A representation of the research process which is further detailed in Chapter 3 is presented in Figure 2.

Plan of Presentation

The presentation of the research generally follows the sequence in which it was conducted. The research problem and the research hypotheses that address the main and subproblems are developed in Chapter 1 along with an overview of the area of study. The objectives of the study are stated and the scope and limitations of the study are addressed.

A review of the pertinent literature is presented in Chapter 2 in order to provide a conceptual framework for the study. The literature review served the dual purposes of developing the need for the study as well as providing the basis for much of the conceptual model presented in Chapter 4. Presented in Chapter 3 is a discussion of the methodology used in this study. An explanation of the causal modeling and system dynamics simulation techniques as they relate to information based decision systems is included and related directly to the theoretical framework developed in Chapter 4 and the simulation model presented in Chapter 5.

A theoretical framework for this research and conceptual model was developed and is presented in Chapter 4. This framework was based on a survey of the literature concerning defense acquisition management, defense economic issues, public policy and decision making and extensive interviews

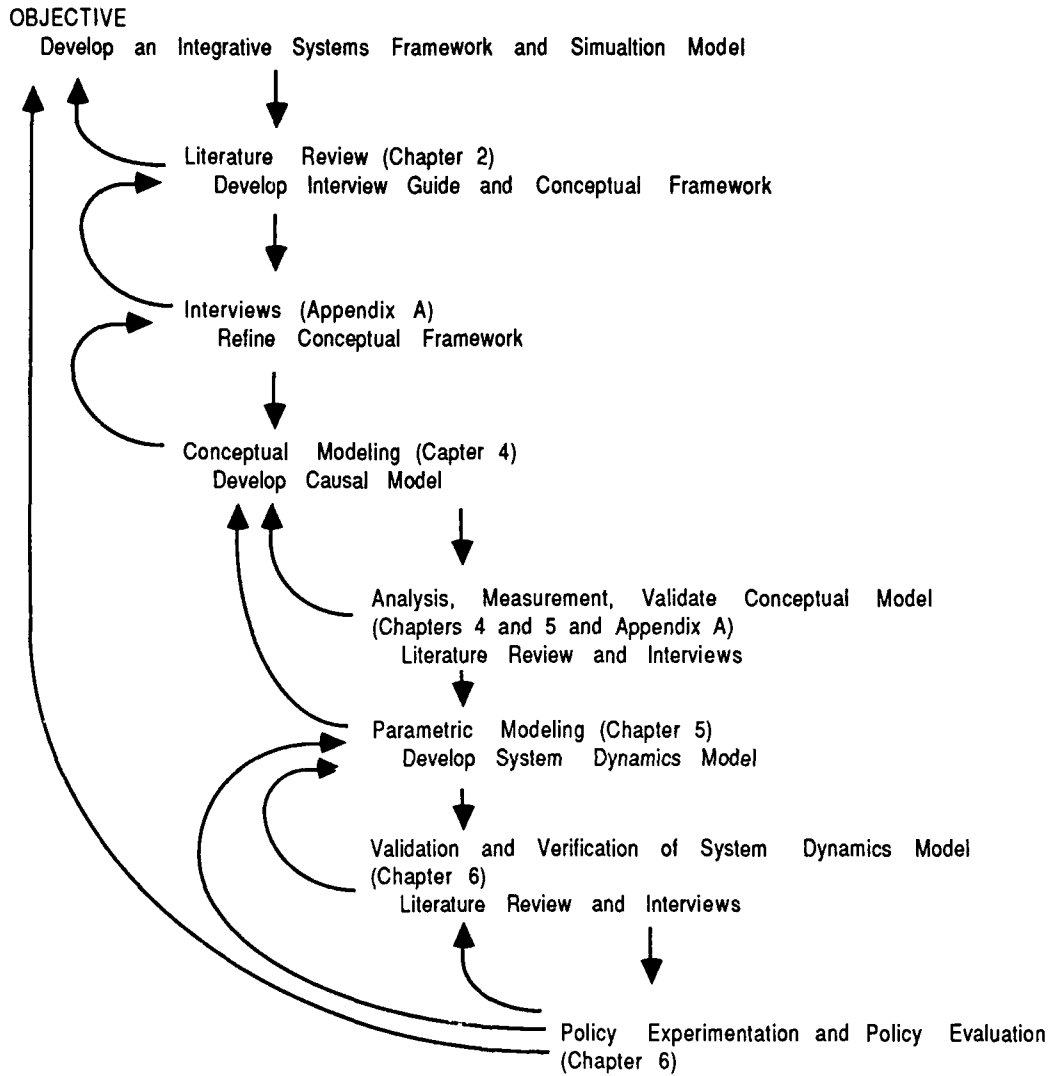

Figure 2. The Research Process

with knowledgeable experts.

The conceptual model described in Chapter 4 was developed with the dual purpose of providing a decision aid to policy makers and providing a basis for the parametric model described in Chapter 5. Chapter 5 contains the description and explanation of the parametric model. A description and the results and implications of the validation process as well as a demonstration of a policy experiment is presented in Chapter 6. A summary of the research, the overall conclusions and implications of the research, and an outline for further study are presented in Chapter 7.

CHAPTER 2

LITERATURE REVIEW

Introduction

A comprehensive review of the literature served three primary purposes in connection with this research. First the review established what has been accomplished in the study of defense acquisition issues in general and policy modeling specifically. Second, the review aiding in determining how these accomplishments fit together as a body of research and establish what research questions remained unanswered. The last purpose was the development of a conceptual framework based on the systemic relationships and variables found in the literature. In order to do this, a review of literature from multiple perspectives was required.

Two of the objectives of this research dealt with the development of systemic models of the defense acquisition system. The conceptual model is presented in Chapter 4 and the parametric model in Chapter 5. This literature review supports the contention that none of the previous modeling efforts have taken such a macro level view as that taken here, and that many of the studies of the acquisition system, or its components, have been descriptive rather than normative. This distinction between descriptive and normative studies is

important because so many of the studies recommend specific policy alternatives. In many cases the implications of the research did not support such specific recommendations. This observation is supported by the fact that many of the suggested reforms have been shown to be ineffective or that they have in fact contributed to the problem of rising weapon system costs (Archibald 1981, Beltramo 1983, Bickner 1964, Dews 1979, Gansler 1980, Perry 1971). The suggested policy alternatives tend to be based on intuition more so than objective analysis. The observation that previous research is relatively micro oriented and that the analyses do not support specific policy recommendations are very much interrelated. Studies which have a relatively narrow focus do not deal with all of the impacts that the recommended policies have outside of the realm of study. The complex interrelations between the system's major subsystems or sectors are what makes the system difficult to manage and what justifies a macro system perspective (Clark et al. 1985).

The studies which were reviewed here were limited in their scope, in terms of the number of components and interrelationships which were included, or by the paradigm which was used. The conceptual framework which was developed in this research attempted to integrate the literature concerning four areas of study. The research which has been conducted in the past treated the problems of weapon acquisition as ones which have their roots in the structure of one or two of the sectors identified in this research. No study has viewed the problems as stemming from the interaction between the sector which supplies

the weapons, the defense industries (industry sector), the sector which determines the need for the weapons and procures them, the Department of Defense (defense sector), the sector which determines the resources which will be made available for the acquisition of weapons, the federal government (national sector), and the sector which provides the demand for the weapons, the threats to national security (threat sector), simultaneously.

The most commonly studied sectors seem to be the defense sector and the industry sector. Most of these studies tend to emphasize the notions of economic and managerial efficiencies. On the other hand the impact of the national sector and the threat sector has been most often written about in the popular press with no scientific studies being completed. This can be seen clearly in the summary of the weapon acquisition literature reviewed which is presented in Figure 3.

The methods which were used to study the different aspects of the weapon acquisition system were broken down into four categories which were not necessarily mutually exclusive. The four categories were: economic analyses, mathematical modeling, other quantitative analyses, and studies based on interviews, personal experience and case study. Of these methods only the studies which have developed mathematical models provide for a means of explicitly testing recommended policy options. It is this feature of the other paradigms which are represented in this literature search which limits their usefulness in policy studies of the weapon acquisition system.

Previous studies of the weapon acquisition system have taken a more limited view of the system than what is proposed here. Peck and Scherer (1962) compared military procurement procedures with their commercial counterparts. Fox (1974) studied the Department of Defense's procurement procedures and the structure of the defense industry. Gansler (1980) studied the structure, behavior and performance of the defense industry. The Packard Commission (President 1986) studied the problem from a Department of Defense perspective as well as from the national perspective in that the impact of Congressional conduct on the acquisition system was included.

What is most similar about these and the vast majority of the other studies is not how the problem was viewed but rather that the idea of military capability was never introduced. Most previous studies have viewed the problem as being one of economic efficiency rather than of military effectiveness. The reason that the threat influence is left out of these analyses is probably due to the difficulty of quantifying military capability in a meaningful way. Military capability is a relative notion and has several dimensions. Military capability can only be discussed relative to other political entities which possess some military capability, there is no absolute scale which makes any sense. Military capability is also multidimensional, and has been measured in terms of strategic or tactical capabilities (Luttwak 1984) as well as along the lines of levels of expenditures in specific categories, such as weapon acquisition, research and development, operations and maintenance, and personnel (Clark

et al. 1985). Only two studies were found which dealt explicitly with the weapon acquisition reform issue and recommended policy alternatives based on an analysis of the comparative military capabilities of the United States and the threats to its national security (Fallows 1981, Luttwak 1984). However both of these studies were primarily subjective and the development of the important notion of military capability was not fully developed and could not be used as the basis for a more quantitative analysis. Chapter 4 presents a conceptual framework, in the form of graphical models, which attempts to integrate the relationships which have been identified in previous studies with the information gathered from interviews conducted in conjunction with this research.

Four interrelated sectors were identified in the literature as having important impact on the procurement of weapons, they were: the defense industry (Fox 1974, Gansler 1980), the national budgeting process (Fallows 1981, Stubbing 1986, Weida and Gertcher 1987), the influence of the threat (Clark 1986, Fallows 1981, Luttwak 1984), and the defense budgeting and acquisition processes (Clark et al. 1985, Coulam 1977, Fox 1974, Peck and Scherer 1962, President 1986). Each of the sectors will be treated separately and the literature will be reviewed by method, and in support of a specific conceptual model. An overview of the sectors, methods, and literature which has been reviewed are presented in Figure 3.

Sector \ Method	INDUSTRY	DEFENSE	NATIONAL	THREAT
ECONOMIC ANALYSIS	Peck (1962) Scherer (1964) Baldwin (1967) McKie (1970) Fox (1974) Gansler (1980)	Peck (1962) Scherer (1964) Fox (1974) Weida (1987)	Weida (1987)	
MODELING	Sapp (1971) Barker (1982)	Sapp (1971) Clark (1985)		
QUANTITATIVE ANALYSIS	Large (1974) <u>Profit '76</u> <u>Payoff '80</u> Stekler (1981) <u>DFAIR</u> (1985)	Hall (1965) Greenberg (1969) Perry (1971) <i>Defense Science</i> Board (1978) Stanley (1979) Dews (1979) Smith (1980) Smith (1981) Beltramo (1983) Lee (1983) President (1986)	President (1986)	
CASE STUDIES, INTERVIEWS, PERSONAL EXPERIENCE		Bickner (1964) President (1970) Coulam (1977) Rich (1976) Archibald (1981) Fallows (1981) Luttwak (1984) Stubbing (1986)	Rich (1976) Archibald (1981) Stubbing (1986)	Fallows (1981) Luttwak (1984) Stubbing (1986)

Figure 3. Weapon Acquisition Literature Summary

Industry Sector

Despite recent news stories which seem to blame the high cost of weapons, spare parts and other military equipment on greed inspired overpricing by individual defense contractors (R. Clark 1985, Fallows 1986, Moore 1987), the conduct of the defense contractors and the resulting prices paid for weapons and spare parts is more likely due to the structure of the system in which they interact with other contractors, the Congress and the Department of Defense (Fox 1974, Gansler 1980).

Three basic methodologies have been used to study the industrial sector of the weapon acquisition system. The three methods are: economic analyses, using microeconomic theories and the industrial organization paradigm; systems modeling; and other quantitative methods which have used accounting data from defense firms.

Microeconomic theory provides a framework for understanding a firm's conduct in varied market conditions given that some fairly rigid conditions are assumed to exist. Two specific market models, pure competition and monopoly, are well defined and understood in terms of their performance and efficiency (Olvey et al. 1984). Accurate pricing models have been developed for both of these markets (Nicholson 1978). Unfortunately none of the industrial markets which the Department of Defense deals with in the procurement of large weapon systems is either purely competitive or a monopoly (Gansler 1980). The markets which the Department of Defense faces in weapons acquisition is

more likely one of a few sellers, that is an oligopoly market.

No general theory of oligopoly markets exists and specific market results are typically indeterminate (Scherer 1970). This situation has led to analysis of the defense acquisition system as a special case. Microeconomic theories concerning supply, demand, and pricing have been widely applied in defense studies (Peck and Scherer 1962, Scherer 1964, Fox 1974, Gansler 1980), however the resulting analysis is typically descriptive rather than prescriptive.

Quite often the studies which have utilized microeconomic theories have also made substantial use of the industrial organization paradigm developed by Joe S. Bain in the 1930's. The paradigm is based on the relationships between *market structure*, *market performance* and *market behavior*. The paradigm was developed as a theoretical framework for dealing with oligopoly markets. Market structure is generally defined in terms of the number and relative sizes of the firms within an industry. Concentration ratios are often used as an indicator of market structure and indicate the market share of some number of the largest firms. Very small concentration ratios indicate that the largest firms do not have much market power and thus the market would behave competitively, whereas in a highly concentrated market, the behavior may be more in line with a monopoly or shared monopoly (Shepherd 1979). The theory implies that *market power is shared by firms within the industry and that the power retained by a firm is proportional to its market share* (Allen 1982). The theory that firms exercising their power, to the extent that they are capable, within a market is the

direct cause of market performance is widely held and provides the basis for the research which is being accomplished (Allen 1982).

The idea that structure is the lone or even the primary causal variable affecting market performance and conduct has been questioned (Kahn 1983) and recent work has been aimed at gaining further understanding of markets where these theories do not do well. The defense market is further complicated by the fact that only one buyer, or at least a very limited number, is present and this along with other factors may explain why purely economic theories have not been effective in explaining defense industry performance and conduct. This also helps explain why the authors who have a decidedly economics slant must *incorporate noneconomic arguments into their analyses.*

The earliest of the economic studies reviewed here provided the basis for much of the following research. Peck and Scherer (1962) compared the acquisition of twelve major weapon procurements to seven "technically advanced" commercial product developments. The study explained the differences in performance on these projects using classical microeconomic and industrial organization arguments. They found that weapon acquisition was characterized by a "unique set of uncertainties." The uncertainties included the quality of technical performance of the systems developed, the system development time, personnel characteristics, and the development cost. In this basically descriptive study Peck and Scherer concluded that a market system can never exist in the production of major weapon systems. Peck and

Scherer's The Weapons Acquisition Process: An Economic Analysis (1962) and Scherer's The Weapons Acquisition Process: Economic Incentives (1964) identified a large number of "profound and debilitating problems" and not coincidentally was published at the same time that an effort was begun to reform the way that the Department of Defense buys its weapons (Fox 1974).

A much more conventional study of the defense markets was Baldwin's The Structure of the Defense Market, 1955-1964 (1967). This study is more representative of the economic market analyses performed for other markets. Whereas Peck and Scherer and their followers (Fox 1974, Gansler 1980) tended to integrate purely economic and noneconomic arguments, the Baldwin study stuck very closely to the industrial organization paradigm. Baldwin concluded that the defense market is unique in "certain crucial respects", that comparisons with other markets or industries would be "misleading or meaningless" and that military procurement policy "cannot and should not be based entirely on the concepts of economic efficiency" (Baldwin 1967, 5). The conclusions of the study indicate that the economics perspective by itself is not effective in studying the broad spectrum of defense acquisition issues.

Fox's Arming America (1974) provides a complete description of the market, including both the buyer and the sellers, and the organizations which interact. The study concentrates on the management issues which Peck and Scherer ignored. These management issues included contract types, source selection procedures, profit negotiation, contract change procedures, and

program management from the perspectives of defense and industry managers.

For much of the study Fox (1974) relied on his experience as an Assistant Secretary of the Army to provide first hand descriptions of the acquisition process and organizations. None of the conclusions or recommendations seem to be based on the economic analyses, rather they seem to be based on a theory of management which Fox did not describe. That is not to say that the recommendations do not make good sense, many of them do. Rather the point is that the recommendations were not the direct result of any empirical research which was reported. This is probably due to the nature of applying economic theories to the study of the defense acquisition process. Most economists have agreed that the market mechanisms are not working and that the defense market is unique in many ways.

The most recent of the broad industry studies was Gansler's The Defense Industry (1980). Gansler accomplished his study with the idea of updating The Weapon Acquisition Process studies (Peck and Scherer 1962, Scherer 1964) and Fox's Arming America (1974) with a focus on the post-Vietnam War era (Gansler 1980). Like the others Gansler (1980) used a combination of microeconomic analysis and the industrial organization paradigm to argue his case. The study depended on empirical evidence to a much greater extent than did Fox (1974). Gansler's conclusions were based on his perception of significant changes in defense spending patterns following the Vietnam War. He concluded that the United States defense industry has

become less efficient in the production of defense materiel, as did Peck and Scherer (1962) and Fox (1974), and also that the defense industry has become "strategically unresponsive" in terms of production speedup capabilities which are needed in times of emergency. Jacques Gansler spent five years in the Office of the Secretary of Defense and twenty years as a manager in several firms within the defense industry. Many of the conclusions which Gansler makes are supported by this firsthand experience, but his empirical analysis is able to stand alone and explicitly supports many of his recommendations.

The economic studies which were reviewed presented a rather clear description of the defense industry and the nature of its relationship to the Department of Defense. These studies were very useful in determining the structure of the industrial sector and its interactions with the Department of Defense. These studies by themselves, however, did not provide a useful framework for considering policy alternatives for the weapon acquisition system. The economic frameworks do not have the capacity to include the threat or political influences which are so instrumental in determining the system's behavior and performance (Stubbing 1986, Fallows 1981, Stockman 1986).

Much of the policy discussion concerning defense acquisition has centered on system behavior rather than the causes of such behavior, that is system structure. In this vein, studies have been conducted to determine whether defense contractors are earning higher profits than commercial manufacturers (Comptroller General of the United States 1971, Department of

Defense 1986, Office of the Assistant Secretary of Defense 1976), whether and why defense industry capital investment is lower than commercial industries (United States Air Force Systems Command 1980), whether and why the defense industry is less competitive than commercial industries (Archibald et al. 1981, Rich 1976), and whether and why procurement cycles are getting longer (Defense Science Board 1977, Smith 1981, Smith and Friedman 1980). These studies tend to be relatively focused on symptoms of the problem. The extent of the problem is reported and suggestions made concerning remedies, however because of this limited scope, the impact of the suggested policies on other system behaviors was often not considered.

The Profit '76 (Office of the Assistant Secretary of Defense 1976) and the DFAIR study (Department of Defense 1986) were conducted to determine the extent of defense industry firm's profits which were considered by many to be too high. Neither of these studies made any policy recommendations, rather they simply reported the findings of what was essentially an industry audit. The Profit '76 study found that defense industry returns on investment were higher than those in the commercial durable goods industries and concluded that this was due to a lower level of investment. The DFAIR study on the other hand used a controversial return on assets measure of profitability and concluded that while defense industry profits were higher than the commercial durable goods industry the reason was most likely the affects of a recession that did not impact the defense industry as much as it did the commercial industries. This

conclusion that the commercial sector profits were low during the 1980's rather than the defense industry profits were too high was widely disputed. The Navy actually sponsored a study to counter these findings.

Partially in response to the findings of the Profit '76 study (Office of the Assistant Secretary of Defense 1976), the Payoff '80 study (United States Air Force Systems Command 1980) was commissioned to determine the state of defense industry capital investments. The study stated that "by far the most potent agent for the reduction of the cost of manufacturing is new or improved technology" (United States Air Force Systems Command 1980, 10). The study found that only 6% of Department of Defense owned machine tools were less than ten years old compared to 31% in the United States as a whole and 60% in Japan. Payoff '80 concluded that defense contracts do not encourage capital investment because of the risks and uncertainties associated with the annual budgets, and the lack of price competition in the defense industry (United States Air Force Systems Command 1980). As with the many other commission reports the recommendations of this study seem to be based on the experience and intuition of the commission members. The study concluded that incentive fee contracting had not worked and that contract termination protection and government/industry shared investments should be utilized (United States Air Force Systems Command 1980).

The notion that a lack of competition within the defense industry has led to higher profits and lower capital investment was mentioned in the profitability

studies and the investment study reviewed here. This notion has become increasingly popular and led to legislation regarding competition in defense acquisitions (Charles 1987, Correll 1986). In a Rand study conducted for the Air Force, Rich (1976) concluded that for too long students of the system acquisition process focused somewhat narrowly on the technological and economic aspects of policy issues while the influence of institutional and organizational factors and pressures on policy formulation and success is usually very great. Although the perceived benefits of competition include lower costs and higher technical achievements, Rich found that the Congress had been unable to take advantage of these benefits (Rich 1976). He also concluded that "consciously or otherwise, the Congress appears to value a flexible approach compatible with preserving the defense industrial base, upholding constituent interests, and using defense spending as a tool of fiscal policy" (Rich 1976, vii-viii). This perspective explains the successful implementation of competitive bidding on the vast majority of contracts which the Department of Defense lets for relatively small dollar items while effective competition on large systems is still an infrequent occurrence (Gansler and Kratz 1986).

In a Rand study conducted for the Office of the Secretary of Defense (Archibald et al. 1981), the authors found that while there is a "general belief" in the Congress, the Office of Management and Budget, and the Department of Defense, that competition should be more widely used, there is no quantitative analytical support for it. The study examined the incentives, disincentives and

uncertainties perceived by program managers and senior Department of Defense officials regarding competition in the acquisition process (Archibald 1981). Prior to full-scale development, competition among firms is quite common and relatively inexpensive. During procurement, however, the current-year costs of competition are much greater and must be weighed against cost savings in the out-years (Archibald 1981). Archibald (1981) concluded that no quantitative evidence exists which provides an adequate estimate of either the costs or benefits of competition in the procurement of high cost weapon systems. He recommend that better records on competitive procurement actions be kept so that future analyses can benefit from a more complete data base.

Many experts agree that since World War II, the ability of defense contractors to deliver high quality weapons to the Department of Defense at low cost and in a timely manner has deteriorated at an increasing rate. In large measure the increases in cost and production schedules was due to matters beyond the contractor's control. The conclusions which have been drawn by most economic analyses of the defense acquisition system were that competitive market forces which might exist in a classical monopsony market (one buyer and multiple suppliers) have been negated by the procedures, regulations and actions of the Department of Defense and the Congress. Over the past forty years, a new set of rules and incentives developed which effectively rule out classical competitive behavior by defense industry firms,

because it was simply not in their best interests. The behavior of the defense industry today is a result of the last forty years of weapons purchases and the system structure which has developed, not specific acquisition regulations, contracting procedures or shifty contractors.

Defense Sector

The defense sector structure determines, to a degree, the behavior of the industrial sector and the effectiveness of the overall weapons acquisition system in terms of its ability to efficiently procure weapons (Fallows 1981, Gansler 1980, Coulam 1977, President 1986). The influences outside of the defense sector; threats to our national security, national budgetary policies, and industrial policies; all have an impact, but it is their interaction with the defense sector, and the Department of Defense in particular, that creates much of the behavior which has been identified by some as being in need of reform (Stubbing 1986, Fallows 1981, Gansler 1980).

The majority of the completed studies of the weapon acquisition system dealt with problems within the Department of Defense. This is due, in part, to the fact that the Department of Defense itself commissioned a large number of studies to look into how it can better manage the procurement of weapons. Eleven of the studies cited here were sponsored by the Office of the Secretary of Defense or the Air Force and conducted by Rand Corporation analysts (Archibald 1981, Bickner 1964, Dews 1979, Greenberg 1969, Hall 1965, Perry

1971, Rich 1976, Smith 1980, Smith 1981, Stanley 1979). The majority of these studies used some type of quantitative analysis to determine the nature of relationships between "key" variables.

Rich (1976) studied the applicability of using competitive strategies to procure large weapons and found that any benefits would tend to be "long-term" and that the Congress has not really supported increased competition for large weapons buys. Archibald concluded that "existing research provides neither quantitative nor qualitative guidance for designing price-competitive procurement strategies" (Archibald 1981, vii).

In a study of acquisition intervals Smith (1980) found that the process of procuring weapons was taking longer but due more to production-rate slow downs than system development delays. Smith further concluded that longer development times were not necessarily harmful as they could be used to shorten the production phase by reducing the need to modify weapons once they were in production. Smith (1980) also found no statistical support for the claim that prototyping resulted in a longer acquisition process. In spite of this, Smith (1981) suggested the use of austere prototypes early on in an acquisition program.

Much of the sponsored research has emphasized management issues rather than strategic policy issues. Perry concluded:

Notwithstanding determined efforts during the 1960s to improve the outcome of major systems acquisition programs by altering contractual approaches and by introducing a variety of management reforms, typical programs continued to exhibit an average cost growth of about 40 percent, a schedule slip of about 15 percent, and final system performance that was likely to deviate by 30 or 40 percent from the original specifications (Perry 1971, v).

In a follow up study carried out nearly ten years later to determine the affect of reforms implemented by Deputy Secretary of Defense Packard, Dews concluded that:

The 1970s programs are achieving their performance and schedule goals to at least the same degree as the 1960s programs did, and are probably doing slightly better. The 1970s programs, moreover, are coming closer to their cost goals by some 10 to 20 percentage points (Dews 1979, ix).

These studies are representative of other government sponsored studies conducted in reaction to a perception that a single force is at work to increase weapon costs. The recommendations of these studies were more concerned with solving the problems of poor cost, schedule and performance estimation than solving the structural problems of increasing weapon costs.

The notion that longer weapon development and production schedules are somehow the root cause of the increasing costs of these weapons is a common thesis. The lengthening acquisition cycle was mentioned in Peck and Scherer (1962), Fox (1974), Gansler (1980), and was the basis of the model and analysis in Clark, Whittenberg and Woodruff (1985). The use of prototypes to reduce technical risks and concurrent production and development to reduce the acquisition cycle have been used intermittently since the 1960's (Coulam

1977, Perry et al. 1971). The two strategies were somewhat at odds with each other as prototyping tends to extend the cycle while concurrent production reduces the cycle by overlapping initial production and system development. The Report of the Acquisition Cycle Task Force (Defense Science Board 1978) found that the production and deployment schedules were increasing due to increased operational testing, reduced concurrency and production stretchouts due to lower funding. The report further concluded that the result of longer program schedules included the fielding of obsolete weapon systems in insufficient quantities with inadequate reliability and capability (Defense Science Board 1978). These conclusions are based on an analysis of the threat which was not included in the study and is, in this respect, representative of other government reports where conclusions were based on assumption, experience or intuition. The recommendations of the study did coincide with those of the Clark, Whittenberg and Woodruff (1985) study, which was based on the development of a system model. Both concluded that the number of systems in development and production should be limited and programs of "marginal" utility should be cancelled. The report also recommended a greater reliance on modified systems rather than new systems and that some level of concurrency be used (Defense Science Board 1978).

A Rand report (Smith and Friedman 1980) presented the results of a detailed historical survey and analysis of weapon system acquisition schedules. The report was commissioned by the Office of the Secretary of Defense (OSD)

to address three questions:

(1) Has the overall acquisition cycle really lengthened significantly during the past few decades, and if so what phases of the cycle have been most affected? (2) Do changes in the length of the acquisition cycle, or any phase of it, derive directly from previous changes in OSD organization or procedures? and (3) Regardless of past trends or events, are there practical ways to reduce the length of the present acquisition cycle without undesirably altering program outcomes? (Smith and Friedman 1980, v).

The study found that the time between issuance of a formal requirement for the system and start of full-scale engineering development has doubled in the past thirty years, but that this trend has not been affected by management changes initiated at OSD during the 1970's (Smith and Friedman 1980). The study also found that the largest change in the acquisition cycle was due to the "steady reduction in average production rates" (Smith and Friedman 1980, v). Smith and Friedman took exception to the Report of the Acquisition Cycle Task Force when they concluded that the increase in the duration of the demonstration and validation phases "should not automatically be deemed undesirable" because "projects undertaken during the 1960's had experienced relatively larger cost growth, schedule slippage, and performance shortfalls" (1980, v). Further the extended initial decision phase did not necessarily result in delayed initial operational capability dates, and if it did, the weapon system usually incorporated more effective technologies due to the delay (Smith and Friedman 1980), rather than being obsolete as characterized by the Defense Science Board (1978).

Peck and Scherer conducted an economic analysis of the defense

acquisition system in order to:

Determine the nature of the relationships between government and weapons contractors in the acquisition of advanced weapons and to analyze the effects of these relationships on weapons performance and the speed and cost of their acquisition (Peck and Scherer 1962, ix).

The study emphasized economic efficiency as a measurement of effectiveness by comparing defense programs with similar commercial programs. Peck and Scherer concluded that neither the economic concept of a market nor common commercial practices applied. While they found that there was no best way to run a weapon acquisition program, Peck and Scherer (1962) did conclude that the development of incremental technical performance not worth its cost, emphasis on timeliness and quality instead of cost, and inefficient use of the *available manpower all resulted in higher cost weapons.*

In a follow-on to the Peck and Scherer (1962) study, Fox (1974) looked at the weapon acquisition process and found that the situation was still "terrible." Fox's analysis was based on a mixture of economic analysis, interviews and personal experience as an Assistant Secretary of the Army. Fox (1974) concluded that "the acquisition process is out of control," that the bargaining positions between the Department of Defense and industry were "unbalanced," that "incentives for efficiency and candor are lacking," and that confusion exists due to "connivance and deception by the DOD-contractor combination." Many of Fox's conclusions and recommendations were based more on qualitative data than quantitative data.

Clark, Whittenberg and Woodruff (1985) have published one of the few

parametric models dealing with the defense acquisition process. The study used the system dynamics approach (Forrester 1961) and was "directed toward understanding and modeling the acquisition system within the Department of Defense" (Clark et al. 1985, 22). The resulting simulation model described the relationships between production affordability, systems in production, systems in development, acquisition cycle length, and program cost. The study identified a policy that could reduce program cost and acquisition cycle length, and concluded that the resulting model could be effective as a "vehicle for policy experimentation," and as an "aid for understanding the complex interactions in the Department of Defense acquisition system" (Clark et al. 1985, 43). Unfortunately the policy which was tested was not one which could be pursued unilaterally within the Department of Defense, which was the frame of reference of the model.

Other studies of the Department of Defense and its role in the acquisition process include Coulam's (1977) case study of the F-111 fighter-bomber acquisition, the report of the President's Blue Ribbon Panel (President 1970) and the books of Fallows (1981), Luttwak (1984), and Stubbing (1986). Each of these studies is based on interviews or personal experience. These sources provide excellent insights into what are typically less quantifiable aspects of the weapons acquisition system.

Luttwak (1984) found that the weapon technologies which were developed were often not well grounded in operational necessity, nor were they

made available for production. Fallows (1981) concluded that the United States military's dependence on a technologically superior force to overcome the numerical advantage that the Soviets have in many potential military confrontations was a root cause of the acquisition system failures. To many authors, it is this dependence on state of the art weapon technology that drives current acquisition policy and has led to rapidly escalating weapons costs (Fallows 1981, Luttwak 1984, Gansler 1980, Coulam 1977).

Maintainability technology received much less attention than force multiplier technology development prior to the 1980's, however its impact upon United States military capability can be significant because of the adverse impact that highly complex weapons can have on maintenance effectiveness and readiness (Fallows 1981). The employment of high technology weapons tends to increase the maintenance requirements initially, while the development and implementation of reliability and maintainability technology lowers it. The current operational readiness rates of the Air Force's and Navy's most advanced fighter aircraft (in the 90% range after being in the 50% range only a decade ago) indicate the impact of increased emphasis on the reliability and maintainability issue.

By and large the United States buys extremely complex weapons as a matter of policy, but not always to counter a confirmed threat capability in the view of some observers (Fallows 1981, Luttwak 1984). These highly complex weapons often require more complex maintenance, more highly skilled

operators and technicians, often result in lower readiness initially, are more expensive to produce, are procured in much smaller numbers, and are much more difficult to accurately budget for as cost estimates tend to be less accurate (Coulam 1977, Fallows 1981, Luttwak 1984, Lee 1983, Perry 1975, Augustine 1985). To the reform minded it seemed a little strange that much of the discussions having to do with defense spending highlighted the fact that the United States was at a sometimes severe numerical disadvantage, yet our acquisition policy was based on ensuring that this continued to be the case as fewer and fewer high cost weapons were purchased (Fallows 1981). Luttwak (1984) made an even more disturbing observation when he wrote that not only was the United States buying too few of the high technology weapons, but the technology that was bought was not always well grounded in operational necessity. This of course is a restatement of the "gold-plating" tendency of which the armed services have often been accused.

Luttwak (1984) found that in some cases, weapons acquisition pressures result from the desire to counter specific threats but also result from the desire to maintain a large defense to counter the aggregated threats to national security and to maintain a position of world leadership. The development of an extremely large and complex defense bureaucracy with too little responsibility spread among too many bureaucrats resulted in a system where internal threats, for example inter-service rivalries and "pork-barrel" politics, seem to drive acquisition actions as much as threats to national security (Luttwak 1984,

Coulam 1977, Stubbing 1986). Whatever the true causes of rapidly increasing weapon costs, it is the unit cost, system development period, and weapon system effectiveness that are the best measures of the efficiency and effectiveness of the weapon acquisition system (Coulam 1977, Stubbing 1986).

The outputs, identified in the literature, which are a result of the structure of the weapon acquisition system include: a lack of joint service cooperation, coordination and planning (Luttwak 1984, Fallows 1981, Stubbing 1986, Packard 1986); acquisition and development of expensive, complex weapons is stressed (Gansler 1980, Stubbing 1986, Luttwak 1984, Fallows 1981); long development and production phases for weapons make cancellations of any weapon system a *no-win proposition for the services* (Stubbing 1986, Fallows 1981); and finally large and growing weapon development bureaucracies within the military services tend to foster more and more complex weapons without ensuring their operational effectiveness (Luttwak 1984, Stubbing 1986).

The inability of the individual services to coordinate their missions and budgets results in overlapping capabilities at the same time that many less exciting but important mission capabilities go underfunded, for example fast ocean-going resupply, close air support, minesweeping and air-to-air and air-to-ground ordnances (Stubbing 1986, Luttwak 1984). Like in the national sector, there was little evidence that the important tradeoffs were being made, or even that they can be made, in the current defense budgeting process (Stubbing 1986).

The inability to make any kind of quantity for quality tradeoffs has reinforced the escalating weapon cost phenomena. The one contradiction to this tendency is very illustrative in that it indicates that there is no permanent decision structure for making the quality/quantity tradeoff. Secretary of Defense Schlesinger was able to get the Air Force to consider buying the winner of the lightweight fighter competition (the F-16) only after promising to buy three additional wings of these aircraft rather than the Air Forces' favored alternative, the F-15 (Stubbing 1986).

Contributing to the escalating cost of weapons is the tendency to build toward fixed force levels, which are set in negotiations between the Department of Defense and Congress, and the disincentives associated with cancelling weapon system programs that are in trouble (Fallows 1981). The fixed force level targets encourage the services to make the limited number of weapons they get the best possible, that is "gold-plated." No quality for quantity tradeoff is possible if the force size is fixed before the weapon is chosen. The cancellation of any weapon system, no matter how much difficulty it has experienced, is viewed by the services as a long delay in the delivery of any new weapon and, therefore, the incentive exists to try to keep the program alive and to fix any problems that are encountered following production. This is very expensive but the alternative to the services is no new weapons at all.

It should be noted that much of the literature was highly critical of the current acquisition strategies but that defenders of the system were able to

make just as compelling arguments. Unfortunately these responses do not typically find their way into the literature. It should also be noted that none of the highly critical studies was completed using a scientific methodology but rather using subjective arguments and selective interviews.

National Sector

The number of studies which have been completed which deal with the impact of the national political process on the acquisition of weapons is really quite limited. There are many studies of the economics of national defense but very few that describe the complex relationships between the federal budgeting process and its impact on the cost of weapons.

Weida and Gertcher (1987) using what they termed a "political economics framework" concluded that the weapon acquisition process was more political than economic. They claimed that the United States has no long term strategy to guide resource allocation at the national level because of the political constraints. Because of this basically reactive posture, Weida and Gertcher (1987) conclude that only a crisis can lead to real reforms. The Packard Commission report echoed these findings when they concluded that:

The entire undertaking for our nation's defense requires more and better long-range planning. This will involve concerted action by our professional military, the civilian leadership of the Department of Defense, the President, and the Congress (President 1986, xvii).

The commission went on to recommend a two year defense budget and a decrease in the ability of the Congress to micromanage using line item budget

approvals. Like Weida and Gertcher (1987) the Packard commission viewed the problem as one of military economic efficiency or maximizing deterrence with a given budget.

Stubbing (1986) recognized the influence that the national political process had on the weapon acquisition process. He characterized much of the impact as being "pork-barrel" politics, but he also recognized the importance of the fiscal constraint that the federal budgeting process places on the acquisition of weapons. Stubbing's book The Defense Game was based largely on the author's 20 years of experience working on the defense budget at the Bureau of the Budget and the Office of Management and Budget.

Classical macroeconomic theory postulates that national income (GNP), consumption, interest rates, government expenditures, investment, taxes and employment levels are all linked together and can be modeled as a system of simultaneous equations (Gapinski 1982, Samuelson 1980). The national sector presented in Chapter 4 is based on this kind of accepted classical macroeconomic structure.

A key element in the growth of the defense budget is the size and rate of growth of the national debt (Stockman 1986). There was considerable support for the idea that the national budgeting process does not make tradeoffs between defense and social spending directly, but rather increases each based on independent criteria (Stubbing 1986). The mediating variable is the debt service component of the budget and the pressure to reduce the rate of the

increase in the national debt, that is the annual Federal deficit (Stockman 1986). The defense buildup of the late 1970's and early 1980's, has not been accompanied by significant reductions in social spending but rather by record deficits, is a clear example that supports this structure (Stockman 1986, Fallows 1986) . Inherent in the difficulty of the Congress to make tradeoff decisions when deciding on spending levels is the process which is used to allocate funds to the defense budget and specific defense line items. Richard Stubbing (1986) made a compelling case that the political pressures which affect defense budgeting preclude any practical or planned ordering of priorities both within the defense budget and in the national budget. A short-term perspective is rewarded as is the advocacy role which is played by individual Congressmen. This structure was supported by the fact that major defense contractors are significant contributors to political action committees, and that the companies along with their subcontractors wield immense political weight as some of the largest employers of Congressional constituents (Stubbing 1986). Even without corporate pressures, Congressmen find it very difficult to make budget tradeoffs that adversely impact their home districts. The closings of essentially obsolete and inefficient military bases and weapon program cancellations which impact home districts are routinely opposed (Stubbing 1986).

A result of this structure was that many weapon system production rates have been slowed dramatically with attendant increases in unit cost (Stubbing 1986). The objective, of course, was to keep production lines open and

preserve jobs. At times, the armed services have exploited this political behavior forming political alliances with Congressmen to defeat cancellations of systems or attempts at reform (Fallows 1981, Stubbing 1986).

Threat Sector

Much like the literature dealing with the national sector there was not a group of literature which has been developed dealing with the impact of threats to national security on the weapon acquisition process. Instead there was a wide variety of possible sources which can shed light on these relationships. In fact the number of readings which could provide insights in this area is very large. Two books which have dealt with weapon acquisition reform issues specifically have been the most informative.

James Fallows' National Defense (1981) and Edward Luttwak's The Pentagon and the Art of War (1984) both made a case for the need to significantly reform the way that the United States military goes about its business including the way that it buys its weapons. Both of these books are somewhat unique in that they deal with the impact of current weapon acquisition policies on military effectiveness, rather than simply treating it as a management or economic problem. Luttwak stated that:

Vast sums of money and the true dedication of many have gone into the upkeep of American military power, only to yield persistent failure in the conduct of war and an unfavorable balance of strength for safeguarding peace (Luttwak 1984, 17).

Luttwak used no quantitative analysis to support his case, rather he based his recommendations on historical analysis.

Fallows (1981) made his case for military reform based on case study and interviews with military "experts." Central to Fallow's arguments was the contention that both sides of the military policy debate in the United States "suffer from the ancient fallacy of measuring input, rather than output" (Fallows 1981, xv). He argued that the problem of military acquisition must be viewed in relation to the capability that is purchased not how much is spent. The conclusions of these two books go beyond the acquisition of defense weaponry, but both sets of conclusions have significant implications for the way that the military currently buys weapons.

The emergence of the United States as a global military and economic superpower following World War II has resulted in current foreign policy based, to a large degree, on the concept of maintaining a balance of power between the United States and its allies, and the U.S.S.R. and its allies (Fallows 1981). Maintaining a political balance of power requires that the United States maintain strategic and tactical military forces sufficient to counteract conventional and nuclear Soviet forces and their surrogates worldwide (Luttwak 1984). In many ways, therefore, the structure of armed forces and defense industrial base has been shaped by the United States' perception of the Soviet threat (Luttwak 1984). Even though the Soviet threat is central to policy debates concerning United States defense policies, some have argued that our policies

do not accurately reflect the threat which it is meant to counter. In the long run this perception of the Soviet threat will almost certainly continue to shape American defense acquisitions (Luttwak 1984, Dyer 1985).

The United States and the Soviet Union each has its own political agenda which it attempts to meet. To some degree the ability to carry out a global agenda is determined by the ability of a nation to project a global military force (Luttwak 1984, Dyer 1985). As a result the Soviet Union and the United States not only increase their respective military capabilities to enable them to carry out political agendas but also as a countering force to influence the other's agenda (Dyer 1985). It is these counteracting forces that characterize the demand for weapons and the military capability that comes with them.

There was general agreement outside of the Department of Defense that the perceived threat a nation faces does not directly impact the acquisition of specific weapon systems, the number of weapons which are produced or the tradeoff of weapon quality for quantity (Fallows 1981, Dyer 1985). There are some notable exceptions, with electronic counter measures perhaps the best example. In most cases, however, the threat usually is used by the actors in the system to justify a given position (Luttwak 1984, Stubbing 1986). The result is that the weapons procurement process is quite well insulated from the actual threat influence and thus does not respond to individual threat capabilities, especially in the short term (Fallows 1981, Luttwak 1984, Stubbing 1986). The impression that the threat is indeed influencing the weapon selection decisions

is fostered by the process by which weapons purchases are justified to Congress and others.

Soviet defense spending levels are determined by the Soviet economic situation and desired military capability (Scott 1987) which tend to increase with a rise in the perceived threat caused by either an increase in perceived United States military capability or global tension. In an article which dealt with the dynamic forces which lead to the arms race, Clark (1986) found similar forces were at work throughout the world, not just in the superpower confrontation. The perception of the threat can obviously differ from the actual capabilities due to faulty intelligence, incorrect analyses, or biases in the threat assessment systems. In both the Soviet Union and the United States, it is certainly the perceived threat which drives the desire for additional capability and not the actual capabilities which are probably unknown (Dyer 1985). Dyer (1985) found the overstatement of threat capabilities to be a common intelligence or bureaucratic ploy that has the unintended impact of increasing the level of global tension and can result in pressure on opponents to develop a capability to counter the capability which has been developed to counter an overstated or nonexistent threat capability.

Summary

Each of the categories of literature which were reviewed here have their own distinctive advantages. The empirical literature gains credence

because it is more susceptible to argument based on objective analysis. The economic studies basically have been descriptive and the recommendations have been based more on the intuitive analysis of the author than on any strict empirically derived economic implications. Modeling studies were less common but seem to hold promise in that they allow for multiple perspectives, including economic, and provide explicitly defined models which can be tested for validity and to perform some policy experimentation or evaluation.

The commissioned studies incorporated economic analysis with a view toward recent historical performance of the system. Many of the conclusions and recommendations seem to be based more on intuition than any explicit analysis. These studies presented a perspective which seems to view the world outside the defense market place as a given. Very few of the recommendations impact the way that the Congress performs its duties, and not much concern is given to the impact on or by the threat and other national priorities.

The popular literature encompasses a vast collection of works in magazines, newspapers, and books which provide a great many perspectives on the problem. These works were based much more on subjective arguments, but their value was not reduced simply because of this. Some of the most insightful analyses were in this group. A general bias seemed to exist in this literature which advocated wide reforms in the current system.

A wide ranging body of literature has been presented which encompasses studies from each of the four sectors, and which have used a

variety of analytical perspectives. The industry studies have characterized the defense market as being very "unique" and highly "uncertain" (Baldwin 1967, Coulam 1977, Fox 1974, Gansler 1980, Greenberg 1969, McKie 1970, Peck and Scherer 1962). In addition quite a few of the studies have recognized the low levels of capital investment and have suggested the use of various incentives to increase the levels (Fox 1974, Gansler 1980, Greenberg 1969, Payoff '80, Profit '76, Rich 1986). Related to the question of capital investment is industry profitability. The Profit '76 study found that industry investment was low and that correspondingly their return on investment was much higher than commercial industries. The DFAIR (1985) study on the other hand found that industry profits were in line with commercial profits, although these findings were very controversial and disputed by a follow-up study for the Navy (Carrington 1986). Gansler (1980) and Coulam (1977) both noted that the performance of the defense industry and defense programs was dynamic and cyclical in nature.

The cyclical nature of the defense programs is evidenced by the continuous revisions of defense acquisition policies. The use of price competition, dual sourcing, prototyping, concurrent production and development, total package procurement, fixed fee contracts, and shorter production schedules have all been policies which were used to decrease the rate of weapon cost increases and later abandoned because they were deemed to have the opposite effect (Beltramo 1983, Bickner 1964, Defense

Science Board 1978, Fox 1974, Gansler 1980, Hall 1965, Lee 1983, Perry 1971, Rich 1986, Smith 1981). There was agreement that the acquisition cycle, the time from determination of a requirement for a weapon to the time that full-scale production begins, is getting longer (Dews 1979, Smith 1980), but there was disagreement about whether this is good or bad (Defense Science Board 1978, Lee 1983).

There seemed to be a growing consensus that the use of prototypes in the weapon development process does reduce uncertainty and results in better decision making (Perry 1971, Rich 1986, Smith 1981). There was wide support for a contention that defense contracts have been ineffective in providing the right incentives to defense contractors in terms of investment behavior as well as in terms of production costs (DFAIR 1985, Fox 1974, Gansler 1980, Payoff '80, Profit '76, Scherer 1964, Stubbing 1986). Perhaps the most widely supported contention was that the Department of Defense is in need of sweeping organizational reform (Coulam 1977, Fallows 1981, Fox 1974, Gansler 1980, Luttwak 1984, President 1970, President 1986, Stubbing 1986, Weida 1987). The nature of the proposed reforms, however, was not always clearly spelled out and many of these same authors noted widespread organizational resistance within the Department of Defense in response to the reform efforts carried out in the past thirty years. The resistance of this organization to change has been evident once again with the resignation of Richard Godwin from his newly created post as "defense acquisition czar" in

September 1987, after less than a year on the job (Smith and Moore 1987).

While the impact of the national budgeting process has not received as much attention as have policies internal to the defense department, the literature available seemed to agree on three points. There does not seem to be a long-term strategy for allocating resources to defense, rather the decisions are made with a short-term outlook (Fox 1974, Gansler 1980, Rich 1976, Stubbing 1986, Weida 1987). The decision process is influenced by selfish political considerations, so called "pork-barrel" politics, at the expense of long-term national interests (Fallows 1981, Fox 1974, Stubbing 1986). And finally, the Congress is reluctant to support pure price competition or any other acquisition policy which would restrict any of its flexibility in determining the recipient of large weapon contracts (Archibald 1981, Fox 1974, Rich 1976, Stubbing 1986). A summary of these conclusions is presented in Figure 4.

This literature review provided the basis for the conceptual and parametric models presented in Chapters 4 and 5 respectively. The research process which was followed in the development of these models is discussed in the next chapter.

	*High Level of uncertainty *Unique market *Low capital investment *High profits *Commercial solutions do not	*Reorganize Mgt *Ineffective incentives *Organization resists change *Technology bias *Acquisition cycle getting longer	*No long term strategy *Micro-management **"Pork-Barrel" *Competition restricts flexibility	*USSR is the threat *Threat used to justify procurements *Requirements process is insulated from threat influence
Sector	INDUSTRY	DEFENSE	NATIONAL	THREAT
Method				
Economic Analyses	Peck (1962) Scherer (1964) Baldwin (1967) McKie (1970) Fox (1974) Gansler (1980)	Peck (1962) Scherer (1964) Fox (1974) Weida (1987)	Weida (1987)	
Modeling	Sapp (1971) Barker (1982)	Sapp (1971) Clark (1985)		
Quantitative Analyses	Large (1974) <u>Profit '76</u> <u>Payoff '80</u> Stekler (1981) <u>DFAIR</u> (1985)	Hall (1965) Greenberg (1969) Perry (1971) Defense Science Board (1978) Stanley (1979) Dews (1979) Smith (1980) Smith (1981) Beltramo (1983) Lee (1983) President (1986)	President (1986)	
Case Study, Interviews, Personal Experience		Bickner (1964) President (1970) Coulam (1977) Rich (1976) Archibald (1981) Fallows (1981) Luttwak (1984) Stubbing (1986)	Rich (1976) Archibald (1981) Stubbing (1986)	Fallows (1981) Luttwak (1984) Stubbing (1986)

Figure 4. Weapon Acquisition Literature Summary of Conclusions

CHAPTER 3

RESEARCH METHODOLOGY

Introduction

In the first chapter, the general nature of the study was outlined. It was presented as a policy modeling study of the weapon acquisition system. Based on a literature review and interviews with executives and politicians who make up the system, a conceptual model and simulation model of the weapon acquisition system was developed and its operation tested. The arrangement of this chapter follows the sequential process of the study and provides a detailed explanation of the specific methodology employed.

The research process model introduced in Chapter 1 now can be expanded to show the progression of the research. The complete sequential process is shown in Figure 5. As can be seen in the figure, the process is not only sequential but also iterative, as the completion of a step may result in a reassessment and reaccomplishment of previous work. The reassessment often resulted in the identification of tasks which needed to be accomplished or reaccomplished because new information had to be taken into account. This research process has been called the system science paradigm and has been adapted to many systems studies (Schoderbek et al. 1985). The particular

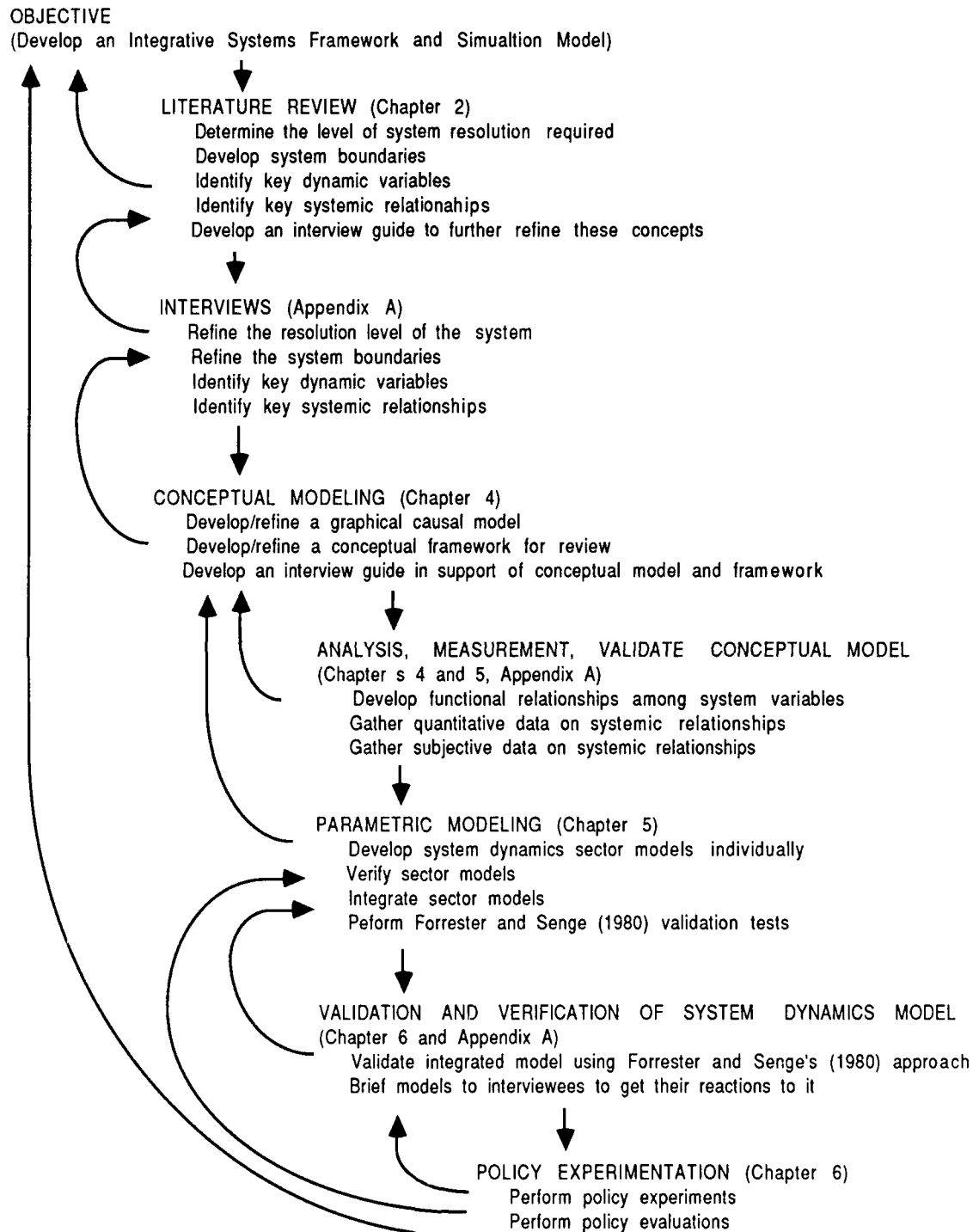

Figure 5. The Research Process Flow

process used in this research is closely aligned to that described by Randers (1980).

The first step in the research process was the determination of the objective of the research. As with any scientific endeavor, the objective of the study evolved as new knowledge was gained. The objective of this research was to develop a policy analysis model suitable for analyzing the relationships between the structure and performance of the weapon acquisition system. Because no such model currently exists, this study was very much exploratory and provides the basis for further research and theoretical modeling in this area.

The second step in the process was a literature review which was presented in Chapter 2. The purpose of this literature review was: 1) to determine the components of the weapon acquisition system; 2) to isolate the important system behaviors in need of analysis; 3) to determine the key variables which establish the system's structure and behavior; and 4) to focus on the relationships, between these variables, that determine the system's behavior. The literature review also was used to identify the methodologies and analytical perspectives which have been used to study this problem or related problems, and as a basis for developing an interview guide for the third step in the research process.

The third step in the research process was to conduct an initial set of interviews in order to further refine the objective of the study as well as to gather

empirical evidence about the weapon acquisition system's structure and performance. (See appendix A for a complete listing of those interviewed and a discussion of the interview process). The fourth step in the research process was the development of a conceptual model. The conceptual modeling process actually began with the initial literature review and continued during and after the first interviews. The conceptual model was constructed using a graphical technique discussed later in this chapter. The next step in the process was also an ongoing procedure and involved the validation of the conceptual model. Each step in the research process had implications for the validity of the conceptual model and resulted in its nearly constant modification. Literature was reviewed with the express intent of validating or refuting, with objective data, the structure of the evolving conceptual model. A second round of interviews was held in which the interviewees were asked to comment specifically on a paper which described in detail the causal model. This subjective validation is very important because no other models of the weapon acquisition system exist at the resolution level used in this research.

The sixth step in the research process was the parametric modeling process. During this step, the DYNAMO simulation language (Richardson and Pugh 1981) was used to translate the conceptual model into a parametric model which could be run on a digital computer. The parametric modeling process, which closely followed the procedures outlined by Randers (1980), Graham (1980), Tank-Nielsen (1980), Mass and Senge (1980), Stenberg

(1980), Bell and Senge (1980) and Forrester and Senge (1980), is further explained in this chapter. The last step in the process included experimentation using the parametric model in order to demonstrate the way in which the model presented in Chapter 5 could be used to evaluate weapon acquisition policy alternatives.

The modeling methodology described in this chapter is based on modeling causal influences and belongs to what is referred to as the refutationist method of scientific inquiry. Refutationism "assumes that scientific knowledge is not absolute truth, but it is centered upon the thesis that scientists can find empirical error - refutations - and can use error as a springboard to improve their theories" (Bell and Bell 1980, 15). An implication of the refutationist approach is that causal models must be conjectured and that the causal explanations must "be vulnerable to empirical error" (Bell and Bell 1980, 19). That is, the causal model must have contact with the "real" world, and thus the concepts must be observable. In fact, the more contact that the model has with the real system the more refutable it is, and the more refutable the better (Bell and Bell 1980). Another important feature of the refutationist approach is that the modeling process is iterative. The emphasis on causality requires that if a causal explanation is refuted then it must be replaced, thus improving the theory.

Conceptualization

The first step in Randers' "four stages of model construction" (1980, 119) is conceptualization. This stage begins with familiarization of the general problem area (Randers 1980). In this study, this step was accomplished with a review of the literature and the development of study objectives. This familiarization phase was used to further define the objective of the study and to determine the causes of certain system behaviors. The initial observation which started this process was the escalation in the cost of weapons and the apparent inability to implement effective policies to slow the rate of cost growth. The literature review provided the basis for initial determination of the level of aggregation, the boundaries of the system under study, and the time horizon of interest for the study. The literature also provided a basis for identifying important system variables and their relationships to each other. Concentrating on these variables and their relationships to each other helped in identifying the key feedback-loops which exist. These variables and relationships were used to describe, in a causal diagram, the basic mechanisms at work in the system. The causal diagram was useful in further focusing the objectives of the study and in developing an interview guide. Stenberg found, when dealing with public policy issues, that interaction with a "reference group" made up of "specialists" from within the system "can ensure that relevant questions are studied, that qualitative information is included in the analysis, and that some users become sufficiently familiar with the research effort so as to be able to

make an informed assessment of its quality" (Stenberg 1980, 294).

The initial interviews served much the same purpose as an exploratory field study and provided additional empirical basis for the conceptual model which emerged. Field studies, while giving up experimental control, have been found to be useful "to discover significant variables in the field situation, to discover relations among variables, and to lay the groundwork for later, more systematic and rigorous testing of hypotheses" (Kerlinger 1973, 406). Simon found the personal interview to be the "most flexible means of obtaining data" (Simon 1969, 252). These interviews served multiple purposes including: refining the level of resolution and aggregation of the model, refining the notion of the system's boundaries and its environment, identifying additional variables and their relationships, as well as building the groundwork for future model validation.

Twenty-nine managers, executives, and experts were interviewed, several of them more than once. The individuals that were interviewed represented the Office of the Secretary of Defense, the Joint Chiefs of Staff, the Secretary of the Air Force, the Chief of Staff of the Air Force, industry, the Congress, the Congressional Budget Office, and the Office of Management and Budget. Representatives of both political parties in the Congress, political appointees, academics, and career civil servants were included in the interview group. A complete listing of interviewees and the interview schedule is presented in Appendix A. Those interviewed were not chosen randomly but

rather for their level of responsibility, their extensive experience and their intimate knowledge of the system. Because of the high level of resolution which this model represents, only relatively high managerial level participants and analysts were interviewed. The size of the group which was interviewed was expanded iteratively until new information from the interviews was not developing. Due to the schedule constraints of those sought for interviews and the sensitivity of the subject matter, not all of those asked to be interviewed took part in the study. Repeated efforts were made to take into account all competing viewpoints.

The selection of a particular interview technique was governed by the purpose of the interview process, which was exploratory in nature. Perhaps because the weapon acquisition system is very large and complex; participants and observers of the system did not agree on system boundaries, the level of aggregation which should be used to view the problem or even what problems exist, much less how to go about solving any problems. The initial interviews were basically free flowing discussions that were directed at answering the following questions:

- (1) What variables and subsystems make up the weapon acquisition system?
- (2) What are the environmental factors?
- (3) What is the system behavior that needs to be corrected?
- (4) At what level must the problem be viewed?

- (5) What policies should be pursued to effect this change?
- (6) What are the key variables which contribute to this behavior?
- (7) How do these key variables interact?

The interview data was analyzed heuristically and integrated with the information from the literature review to form the basis for a conceptual framework. This step is recommended by Bell and Senge (1980) and Randers (1980). A more complete description of the interview process is included in Appendix A.

The next step in the process was the conceptual modeling phase. A commonly used method for dealing with complex system structures to focus on *important interactions and relationships within the system* is causal analysis or influence diagramming (Coyle 1977, Richardson and Pugh 1981). Use of this technique required that the single interaction between each pair of interacting variables be considered in turn, and a causal relationship hypothesized. The relationships which were hypothesized were supported by the literature review and the interviews. For example, a relationship between the number of weapon system units produced and the unit production cost of those weapons might be hypothesized. The relationship might be such that an increase in the number of units produced would result in a lower unit production cost. That is, as units produced goes up, there is a tendency for unit production cost to go down. To model the relationship, one would pose the question: if the number of weapons produced increases, would the unit cost of those weapons tend to increase or

decrease? The answer to the question forms a causal hypothesis, the nature of which is indicated by the plus or minus sign at the head of an arrow drawn from one variable to another. A minus sign indicates that the second variable moves in the opposite direction of the variable which is impacting it, a positive sign would indicate that they tend to move in the same direction.

If there is also a causal relationship between the two variables in which changes in the impacted variable causes a change in the impacting variable, then that relationship is also hypothesized and a causal loop can be said to exist. In this case, if a change in the unit production cost leads directly to a change in the number of units produced, then a second arrow should be added. The two relationships between these two variables form a feedback loop which, in this case, is positive. That is, the relationships are such that any movement in a variable's value is reinforced by the impact of its relationship with the other variable. In this example, if the number of weapons produced decreases, the effect would be to raise unit cost, and as unit cost increased, the number of weapons produced would go down resulting in higher unit production costs, and so on. In a causal model this relationship might be portrayed as shown in Figure 6.

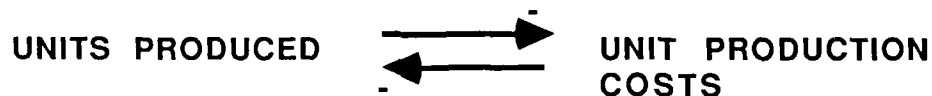

Figure 6. Example of Causal Mapping

A negative feedback loop, on the other hand, would create a balancing or equilibrium-seeking relationship that would tend to maintain some degree of stability. For example, if a relationship was formed between "pressure to increase defense spending" and "defense spending" as shown in Figure 7, the resulting feedback loop would be a negative one. In this case, as the pressure to increase defense spending increased, it would tend to increase defense spending as a result. Additionally, if defense spending increased, the pressure to increase defense spending would tend to recede or move in the opposite direction. This loop with an odd number of negative signs results in a negative feedback loop. Negative loops are stability producing structures within systems as they often incorporate system goals and goal attainment variables.

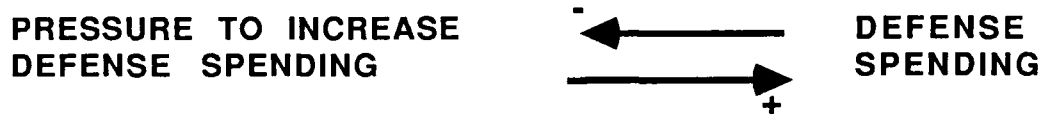

Figure 7. Example of a Negative Feedback Loop

A sector model was developed for each of the four subsystems or sectors, which were identified during this phase and shown in Figure 1 of Chapter 1, using the causal diagramming approach. The difficulty in proposing such relationships is not in formulating individual relationships or hypothesizing the direction of the influence but in measuring its magnitude and dimension and in validating the existence of the relationships (Clark 1987). That step, of course, was part of the parametric programming phase of the modeling

process. Prior to beginning parametric programming, the conceptual model was exposed to criticism in accord with the refutationist method of scientific research. A second round of interviews was accomplished in order to get feedback from those interviewed concerning the conceptual model. A complete description of these interviews and a list of those who were interviewed is presented in Appendix A. Each of those interviewed was sent a copy of the conceptual model in the form of a paper describing the research goal, conceptual modeling methodology, and the relationships hypothesized in the sector models. The conceptual model was further refined following these interviews and the process of identifying methods to operationalize the concepts in the conceptual model was begun. Further review of the literature was accomplished to develop support for the model and to develop data sources for parameterizing the hypothesized relationships.

Formulation

The second phase in Randers' (1980) four step process is formulation. This phase of the iterative modeling process involved the development of a parametric simulation model based upon the conceptual model. Simulation models have the ability to account for complex, nonlinear, dynamic relations, with a variety of interrelated and interacting variables. The particular simulation methodology used in this study was system dynamics which was initially developed as industrial dynamics (Forrester 1961).

Industrial Dynamics is the study of the information-feedback characteristics of industrial activity to show how organization structure, amplification (in policies), and time delays (in decisions and actions) interact to influence the success of the enterprise. . . . It is a quantitative and experimental approach for relating organizational structure and corporate policy to industrial growth and stability (Forrester 1961, 13).

The system dynamics philosophy is based on the belief that organizational behavior is caused primarily by the organizational structure in terms of information flows (Forrester 1961). System dynamics is predicated upon the notion that complex systems are comprised of feedback loops, which are chains of cause and effect loops.

System Dynamics is the application of feedback control systems principles and techniques to managerial, organizational, and socioeconomic problems. For managerial usage, System Dynamics advocates seek to integrate the several functional areas of an organization into a conceptual and meaningful whole, and to provide an organized and quantitative basis for designing more effective organization policy (Roberts 1978, 3).

The system dynamics approach to systems modeling was well suited to the specific research presented here because of its emphasis on information flows, feedback mechanisms, and the decisions based on that information. System dynamics models have been used to simulate and analyze complex decision making structures, and to perform policy evaluations with these systems (Clark 1985, Clark 1986, Hall 1976, Hall and Menzies 1983, Roberts 1978, Stenberg 1980). The system dynamics method uses a system of level and rate equations to represent the system structure. The levels represent accumulations of resources and information about levels provide the basis for

the decisions which are made. The rate equations determine the rate at which the level variables change and embody the decision structure of the system. The DYNAMO simulation language (Richardson and Pugh 1981) was used to develop the parametric model.

Testing

The third step in the modeling process described by Randers is testing the basic mechanisms that create the reference mode and its output behavior (Randers 1980). Each of the sector models was developed individually and tested prior to integrating the models into a single macro-system model. The testing process or validation of each of the models followed the outline proposed by Forrester and Senge (1980). The purpose of the validation process was to increase confidence in the model as a policy analysis tool. This approach to model validation is in accord with Coyle (1977) who stated that a system dynamics model should be judged on its ability to give insights into complex problems and to provide policy alternatives rather than by its specific conclusions.

The confidence building tests proposed by Forrester and Senge (1980, 227) include tests of model structure, model behavior and policy implications, and are presented in Figure 8. The results of each of these tests is addressed in Chapter 6. The testing of the model implies the "comparison of the model to empirical reality" (Forrester and Senge 1980, 210). However, empirical reality

Tests of Model Structure

- a 1. Structure Verification
- a 2. Parameter Verification
- a 3. Extreme Conditions
- a 4. Boundary Adequacy
- a 5. Dimensional Consistency

Tests of Model Behavior

- a 1. Behavior Reproduction (symptom generation, frequency generation and relative phasing, multiple mode, behavior characteristic)
- 2. Behavior Prediction (pattern prediction, event prediction, shifting-mode prediction)
- a 3. Behavior Anomaly
- 4. Family Member
- 5. Surprise Behavior
- 6. Extreme Policy
- 7. Boundary Adequacy
- a 8. Behavior Sensitivity

Tests of Policy Implications

- 1. System Improvement
 - a 2. Changed-Behavior Prediction
 - 3. Boundary Adequacy
 - a 4. Policy Sensitivity
-

a Core Tests

Figure 8. Forrester and Senge's (1980) Confidence Building Tests.

is not limited to numerical statistics, therefore, "model structure can be compared directly to descriptive knowledge of real-system structure; and model behavior may be compared to observed real-system behavior" (Forrester and Senge 1980, 210).

Tests of Model Structure

The first test of model structure is the "structure-verification test" which is aimed at verifying that the model structure does not "contradict knowledge about the structure of the real system" (Forrester and Senge 1980, 212). The basis for this test in this research was a comparison of the model's structure with the information concerning system structure gained from a review of the literature and the interviews conducted with experts which are reported in Appendix A. The purpose of the test was only to determine whether or not the important model structures have real system structures to which they correspond, not to determine whether the chosen structures were the really important ones or whether they had been implemented in the best fashion. This "core" test was applied to every equation in the model individually.

The second test of model structure is the "parameter-verification test" which entails "comparing model parameters to knowledge of the real system to determine if parameters correspond conceptually and numerically to real life" (Forrester and Senge 1980, 213). The notion of conceptual correspondence refers to the parameters matching elements of system structure. Each parameter in the model was subjected to this "core" test.

The third test of model structure is the "extreme-conditions test" which entailed tracing through all of the determinants of each rate equation in the model to determine the plausibility of the resulting rate of change when extreme conditions in preceding level equations were reached. Forrester and Senge claim that "much knowledge about real systems relates to consequences of extreme conditions" and that "if knowledge about extreme conditions is incorporated, the result is almost always an improved model in the normal operating region" (1980, 213). The extreme conditions test was useful for discovering flaws in model structure and in enhancing the "usefulness of the model for analyzing policies that may force the system to operate outside historical regions of behavior" (Forrester and Senge 1980, 214). Every rate equation in the model was subjected to this "core" test.

The fourth test of model structure is the "boundary-adequacy test" which seeks to determine whether or not the model level of aggregation was appropriate and whether or not the model includes all of the relevant structure. The conduct of this test is based largely on the purpose of the model and so the test was conducted with reference to the policy analysis examples cited in Chapter 1. It is highly likely that any specific analysis using the parametric model described in Chapter 5 will require that the model be modified in order to test additional policies. In that case, this test would need to be repeated in order to indicate which concepts would need to be added or modified. It must be remembered that any model must be viewed relative to the purpose for

which it was developed.

The fifth and final test of model structure is the "dimensional-consistency test." The test entailed a dimensional analysis of the model's rate equations to ensure that the same units of measure appear on both sides of each equation after mathematical manipulation. The use of scaling parameters to pass this test leads to the conclusion that no real-life structure has been identified that corresponds to the model's structure. For this reason this test was especially helpful in identifying faulty structures when performed in conjunction with the parameter verification test. This "core" test was applied to every equation in the model.

Tests of Model Behavior

Forrester and Senge (1980) describe eight tests of model behavior which deal with evaluating model generated behavior in comparison with actual data as well as to subjective expectations of system behavior. Some of these tests were quite important because they were more objective than the others and because the purpose of the model was to replicate system behavior in the hope that the model's structure, which generates such behavior, would lead to insightful observations concerning the real system. The first such test is the "behavior-reproduction test" which entailed examining how closely model generated behavior matches the observed behavior of the real system.

The behavior of the model was compared with historical time series data. In the

threat sector, the model output was compared to Soviet annual defense expenditures. In the national sector, model output was compared to United States budget data concerning annual gross national product, annual defense expenditures, annual Federal deficits, and annual social expenditures. In the defense sector, the model output was compared to annual defense expenditures in each spending category, number of systems in production, number of systems in development, force size, weapon system unit cost growth, weapon system production period and weapon system development period.

The second test of model behavior described by Forrester and Senge (1980) is the "behavior prediction test" in which model behavior is judged subjectively against future behavior patterns of the real system. This test is not a "core" test and was not performed. The test is discussed further in Chapter 6. The third test is the "behavior-anomaly test" in which model behavior was compared to system behavior and any "anomalous features of model behavior which sharply conflict with behavior of the real system" were "traced to the elements of model structure responsible for the behavior" at which point "one often finds obvious flaws in model assumptions" (Forrester and Senge 1980, 220). In the process of developing the model, progress was judged based on comparisons of model output with available time series data. In cases where the reference behavior was not produced, the model structures were examined in order to determine the reason. This "core" test was conducted repeatedly throughout the model's development. Specific results are reported in Chapter 6.

A test related to the "behavior-anomaly test" is the "surprise-behavior test." Forrester and Senge state that "the better and more comprehensive a system dynamics model, the more likely it is to exhibit behavior that is present in the real system but which has gone unrecognized" (1980, 221). When such behavior is observed in the model, the model builder must determine the causal relationships leading to the behavior, and compare these causes to the real system. When this procedure leads to the identification of previously unrecognized system behavior the "surprise-behavior test" adds to confidence in the model. In cases where the causes could not be substantiated, the behavior anomaly test resulted in a modification of the model. This test could *not be planned for in advance* as it depended on the model producing "surprise behavior" and the recognition of the behavior by the modeler.

The "extreme-policy test" involved altering rate equations in an extreme way and observing the model's behavior in these conditions. The key question was "does the model behave as we might expect the real system to under similar conditions?" If the answer was yes, confidence in the model was increased. This test was conducted in conjunction with the rate equations which correspond to the number of weapon system development starts, the number of weapon system production starts and the Soviet's share of their gross domestic product allocated to defense.

The "boundary-adequacy test" of behavior was conducted to determine whether or not additional model structures were necessary in order to generate

observed system behaviors. The test was conducted by running the model with and without individual model structures to determine how those structures influenced the behavior of the model. As with the "behavior anomaly test", this test was conducted fairly routinely during the modeling process.

The final test of behavior proposed by Forrester and Senge (1980) is the "behavior-sensitivity test" which focused on the sensitivity of model behavior to changes in model parameter values. The test was meant to determine whether plausible changes in parameter values resulted in the model failing behavior tests which were previously passed. When changing parameter values were not found to cause such failures in model behavior, confidence in the model was increased. This test was performed for every parameter.

Tests of Policy Implications

Forrester and Senge (1980) propose four different tests of policy implications for system dynamics models. The first test which they discuss is the "system improvement test" in which policies which are found to be beneficial after working with the model are implemented and found to improve the behavior of the real-world system. While this test would seem to be the ultimate test, implementing it within the system described in this research would have taken quite a long time as the impact of any policy changes are not readily observed in the weapon acquisition system. Other difficulties also arise. These have to do with implementing any policy effectively and also with interpreting

the cause and effects, because in such a complex system it could be argued that improvements were due either to the modified policy or some other factor or factors. Such a test is well beyond the scope of this research.

A second test of policy implications is the "changed-behavior-prediction test" in which policies are changed in the model and the resulting behavioral changes are evaluated subjectively. One strategy for this test would be to implement policies in the model which have been pursued in the real system and determine whether the model behaves as the system did. Unfortunately, this approach was not viable because the history of policy changes which affect the weapon acquisition system, characterized by the Packard initiatives of 1970 (Dews et al 1979) have been directed at relatively micro level issues which are not within the resolution of this model. More current policy changes such as the Carlucci initiatives, or those resulting from current legislation, have either not been implemented or were also directed at micro issues and have not had time to impact the system's behavior or apparently have had no real effect. As noted, the lack of system oriented policy options was one of the prime factors which led to the undertaking of this research. This test was conducted in conjunction with the policy experiment presented in Chapter 6.

The third test of policy implications suggested by Forrester and Senge (1980) is the "boundary-adequacy policy test." This test attempted to evaluate the chosen model boundaries by determining how policy recommendations might be altered with changes in the boundaries of the model. This "core" test

was conducted using the policy alternatives as outlined in Chapter 1.

The final test for building model confidence is the "policy-sensitivity test" in which changes in the policy recommendations of the model were evaluated in reference to changing parameter values. If in spite of changing parameter values the same policies would be recommended then confidence in the model was improved. The parameter values were modified in the same plausible range that was used in the previous parameter sensitivity test (Forrester and Senge 1980). Each of the parameter values in the model was modified and their impact upon the policies described above was evaluated.

Implementation

The last phase of the modeling process was the policy experimentation phase. This is the phase which Randers (1980) refers to as implementation. The purpose of this phase was to perform sensitivity analysis, policy evaluations, policy experimentation, and the "translation of study insights to an accessible form" (Randers 1980, 119). Sensitivity analysis is the process of determining which variables and parameter values in the model have the most impact upon the model behavior when changed. Similar tests are included as part of the validation process. If, however, the model behavior were sensitive to particular parameter values, this would have significant policy ramifications. The second step is policy evaluation that involves the testing of specific policies which have been suggested. This is different than policy experimentation or

policy analysis in that policies developed outside of this study are run with the model and their effects on system behavior observed (Greenberger et al 1976). The last step is policy experimentation in which policy alternatives which are developed as a result of the modeling process are tested. These policy alternatives often will be a direct result of the modeling process (Hall 1976, Hall and Menzies 1983).

This study emphasized the development of a simulation model which can be used to demonstrate the usefulness of a policy model in the weapon acquisition policy arena. The implementation phase, therefore, was not stressed, but instead, the development and validation of the model was of prime concern in this research and took precedence over actual policy evaluations.

Schoderbek stated that complexity is "defined by the number of elements in the system, their attributes, the interactions among the elements, and the degree of organization inherent in the system" (Schoderbek et al 1985, 90). The weapon acquisition system as it was envisioned in this study is highly complex according to this definition. It involves a large number of entities, with dynamic and nonlinear interactions and multiple attributes. The use of the particular modeling methodology presented in this chapter was well suited to this research because of the complexity of the system being modeled, because of the policy orientation, and because of the strong influence that information and perception have on the system's behavior. The conceptual model is presented in the next chapter, the parametric model in Chapter 5.

CHAPTER 4

CONCEPTUAL MODEL

Introduction

Two of the objectives of this research dealt with the development of systemic models of the weapon acquisition system. The conceptual model, presented in this chapter, resulted from the modeling process described in Chapter 3 and was used to develop the policy-analysis simulation model presented in Chapter 5. The conceptual model is usually an intermediate step in the process of developing a parametric simulation model rather than an important output. Since no corresponding conceptual model exists, however, this model can be useful as a stand alone decision aid.

The basis for the conceptual model was the literature review presented in Chapter 2, the interviews discussed in Appendix A and an analysis of the information gathered from these sources. The conceptual model is made up of four interacting sector models which correspond to the literature review of Chapter 2. The effects of threat and global pressures; the setting of national priorities; the weapon development, contracting and production processes; and the interaction of United States military capabilities with the threat capabilities form the basis for the systemic model presented in this chapter. The defense

sector interacts with the other three sectors to determine the requirements for national defense and to manage the transformation of the resources allocated to national defense into military capability. The Industrial sector interacts with the defense sector and the national sector to produce the weapon systems which are procured. The national sector interacts with the other three sectors making tradeoffs between social, fiscal and defense priorities. The threat sector interacts with the defense and national sectors and creates a demand for military capability based on the interacting political agendas of the two superpowers. The four sectors and their functions are presented in Figure 9.

As shown was shown in Figure 1 of Chapter 1, the sectors interact with *each other through specific variables within them*. In complex systems such as this, the interactions typically are projected through a series of information feedback mechanisms existing between variables (Coyle 1977, Forrester 1961, Richardson and Pugh 1981). In subsequent sections of this chapter, these interacting feedback mechanisms are discussed in detail. Hall (1976, 1983), Hall and Menzies (1983) and Axelrod (1976) have demonstrated the importance of focusing on feedback mechanisms when attempting to understand complex system behavior. Before a more detailed analysis, however, a discussion of the overall system structure will be presented.

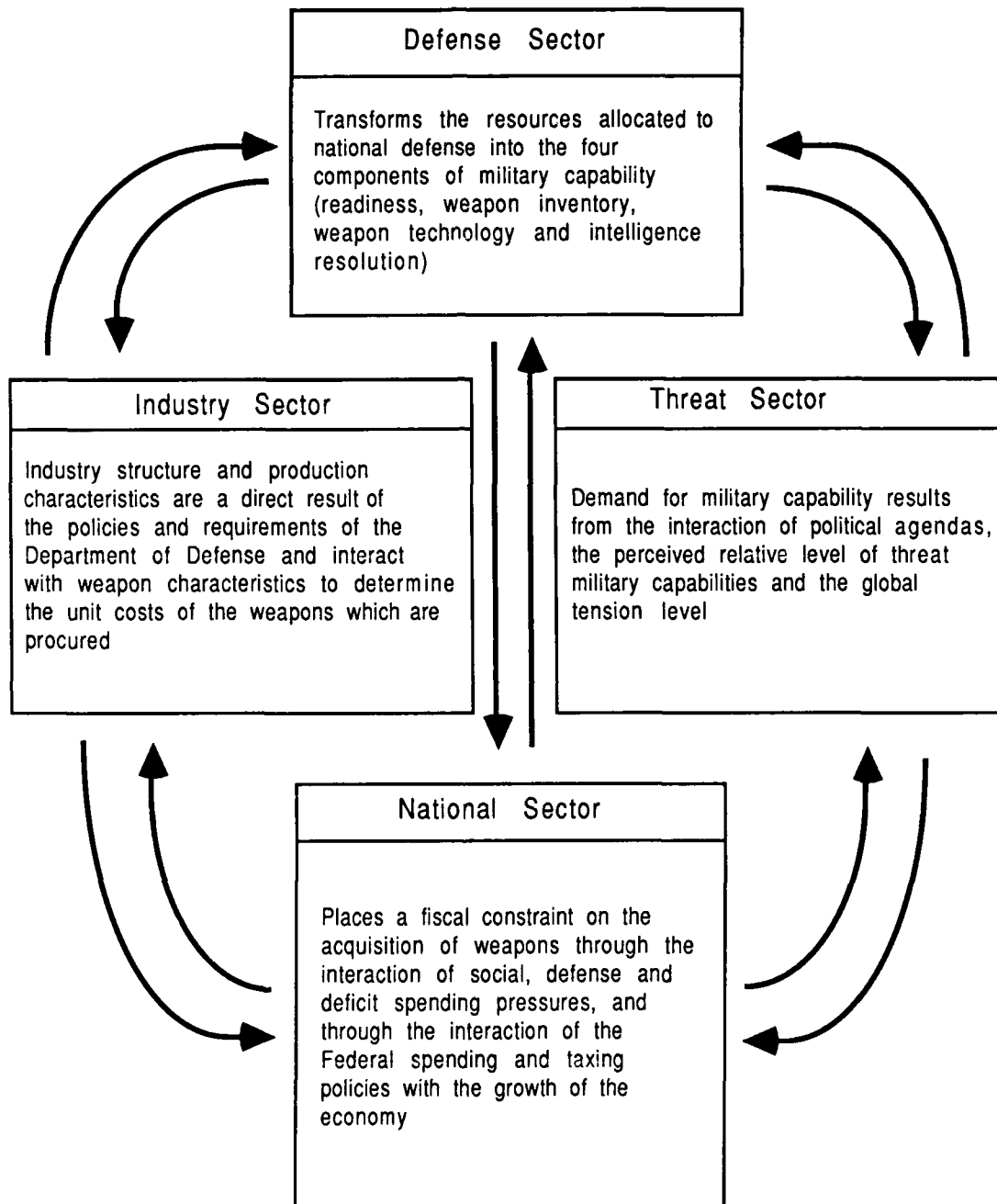

Figure 9. Weapon Acquisition System Structure

System Structure

The military threat, which to a large degree has been used to justify defense expenditures, stems from the perception of Soviet military capability (Luttwak 1984). Even in theaters where the United States would not expect to face Soviet troops, the probability is high that United States forces would face military units trained and equipped by the Soviets. For this reason as well as a desire to develop a parsimonious model, the threat sector explicitly reflects only the Soviet influence. The real concern was not whether the Soviets are the only threat the United States faces, but that the Soviet threat is the one to which the United States reacts (Brown and Korb 1983).

The threat sector and the defense sector interact through the defense spending and military capability variables. These two sectors embody the basic relationships, identified by Clark (1986), which encourage the current arms race. Increased military capability by either of the superpowers results in a perception of increased global tension which spurs increased military spending by the other. This results in increased military capability that results in a perception of increased global tension and so on.

The threat and national sectors interact with the arms race forces by limiting the positive feedback effects through the application of an economic constraint. That is, defense spending on both sides is limited by the resources of the two countries. The interactive relationships which are at work on the Soviet side are not as well understood as those on the United States'

side where increasing budget deficits have resulted in pressure to reduce the rate of increase of the federal budget and the defense budget.

The national sector was included to represent the budgeting and resource allocation issues confronting the United States government. Much of what has been included was based on classical macroeconomic theories. The sector incorporates GNP, investment, consumption, interest rates, population growth and three components of the federal budget (defense expenditures, social welfare expenditures and debt service). The national sector and the defense sector interact primarily through the defense spending variable. The national sector must weigh the importance of threats to national security, which demand additional military capability, against social demands and pressures to reduce the spending and revenues imbalance. The defense sector translates defense spending into military capability which in turn results in the United States being able to utilize a wider range of political options internationally.

The defense sector was included in order to detail the process by which the resource allocations are transformed into specific military capabilities. The defense budget, like the federal budget, was decomposed into the four components of operations, maintenance and personnel; acquisition; research and development; and intelligence resolution. The procurement process was represented by several complex variables that are addressed in a later section. The defense sector and the industrial sectors interact to determine the unit cost of the weapons which are developed and produced as a result of the decision

process within the defense sector. Decisions about which weapons and how many of these weapons are produced was determined in the defense sector taking into account threat requirements and budgetary constraints. Stubbing (1986) identified the ability of the weapons producers to affect these decisions based on their political influence. It is quite clear that any increase in the cost of a weapon system over its initially estimated cost often results in fewer units being purchased, and in this way the industry impacts the defense sector decisions. Gansler (1980) found that a primary cause of increased production costs in the defense industries was the overcapacity which existed at the prime contractor level. Gansler (1980) stated that low capacity utilization in the defense industries results in little or no pressure for firms to invest in more efficient means of production. Rich (1986) and Gansler (1980) both concluded that the technology of the weapons produced also accounted for the rising unit cost of these weapons. The structure of the defense industry is impacted by the defense sector through the weapon technology variable, the numbers of systems produced and the number of units of each system which are produced.

The industrial sector interacts with the other sectors through the relationship between industrial capacity, production technology, capacity utilization, production costs and weapon unit cost. The industrial sector is included because the unit costs of weapons is determined largely by industry characteristics. A macro level model which details the interactions among the four sectors is presented in Figure 10. Although this macro level model is

useful for identifying the ways in which the four sectors interact, its resolution is such that some important causal relationships are not included. In the following sections of this chapter, each of the sectors will be expanded upon and a more detailed causal map presented. The conceptual model presented in Figure 10 provided the bases for the even more detailed conceptual models discussed later and also provided the structure for the parametric simulation model presented in the next chapter.

Threat Sector

In the threat sector model, the primary feedback structure involves the the impacts of increasing United States and Soviet military capabilities, rising global tensions, and the desire to reduce global tensions by these two superpowers. The United States and the Soviet Union each has its own political agenda which it attempts to meet. Each has a desire for "global influence" as well. The ability to carry out a global agenda and gain influence is determined, to a large degree, by the ability to project a global military presence. The ability to project a military presence is determined by the level of resources allocated to each Nation's military forces. As a result, the Soviet Union and the United States not only increase their respective military capabilities through increased defense expenditures that enable them to carry out their respective political agendas, but also as a countering force to influence the other's agenda. These counteracting forces are represented in the threat

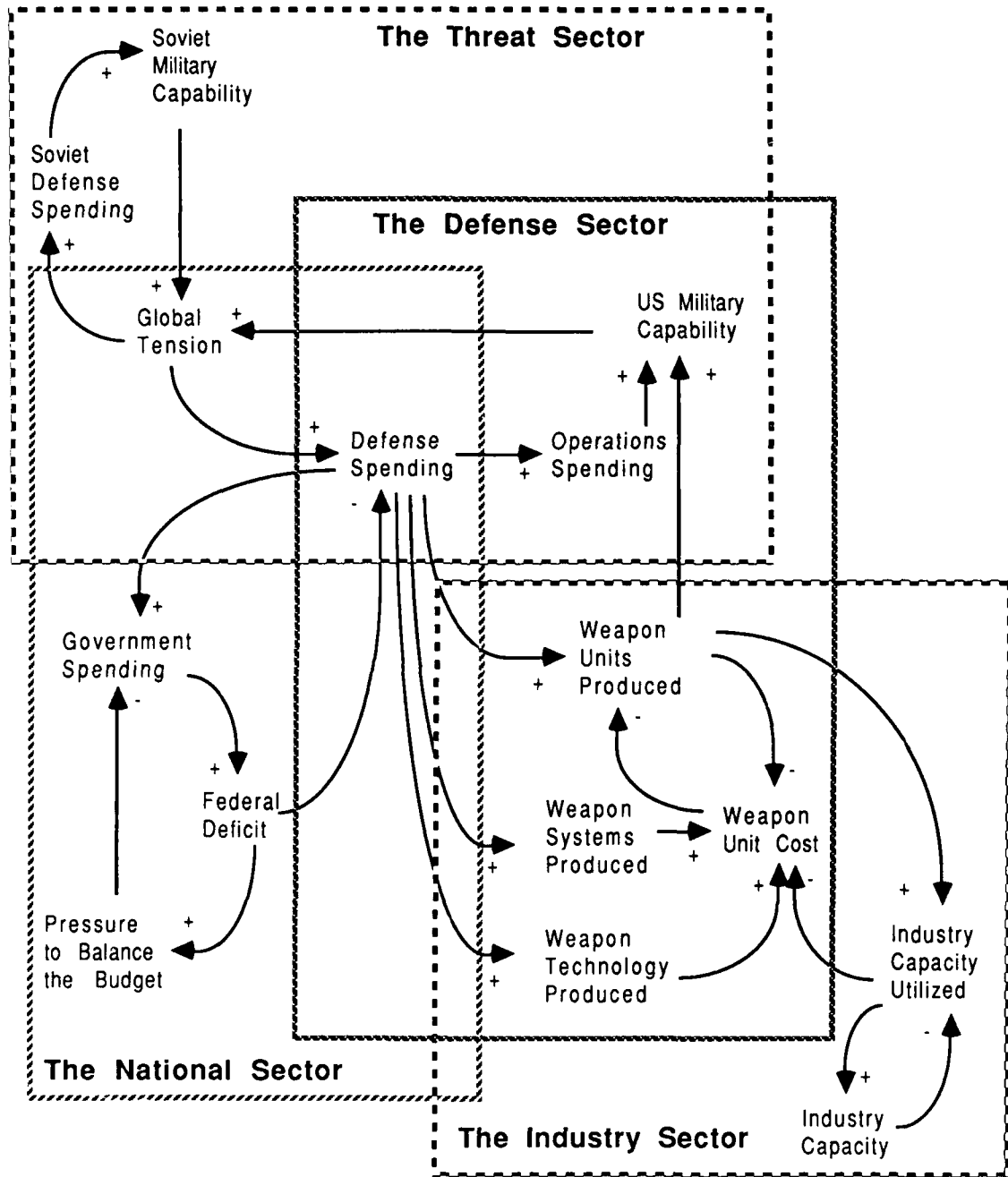

Figure 10. Weapon Acquisition System Causal Map

sector.

The structure of what has been labeled the "arms race" can be clearly seen when only a few of the variables in the threat sector are viewed. The key but simple loop structure in the sector is shown in Figure 11. As long as each nation is willing to accept military parity, a relative balance is maintained. If, however, either one of the superpowers has the perception that it is at a military disadvantage to the other, spending will increase and the ratio of Soviet to United States capability will fluctuate and the "race" will be sustained.

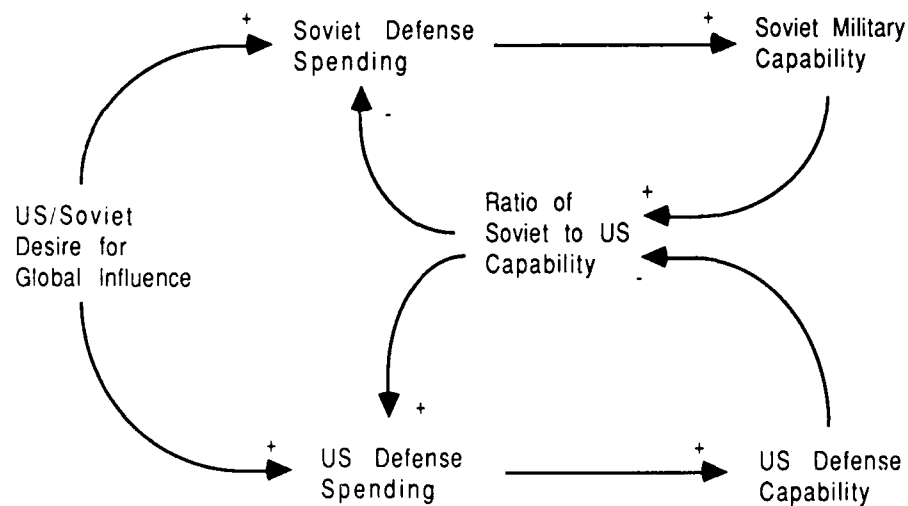

Figure 11. Threat Sector Basic Structure

At the same time that each nation desires influence, each also would like a world free of what has been called "cold war tensions" or what is called here "global tension." When variables are added to the model to capture the desire

to reduce tensions, the sector appears as in Figure 12. Global tension is a measure of how close the superpowers are to open conflict, either directly or through surrogate forces. Global tension is a primary determinant of the pressure for defense spending in both the United States and the Soviet Union. As global tension increases, higher states of readiness are required and annual defense expenditures are increased commensurately. Global tension tends to increase when either superpower's politically aggressive behavior increases, and when a perceived shift in the balance of power occurs due to a change in perceived military capabilities. It is the desire to avoid war, and reduce tensions, that tends to mediate aggressive political behavior on both sides. The *desire to reduce tensions by either nation rises with an increase in global tension and falls, through feedback effects, when tensions are low.*

Although the basic structure of the threat sector model is presented in Figure 12, there are other forces and a finer level of detail that should be included. Also, the linkage of this sector to the United States political structure, captured in the national sector, must include the structure that limits defense spending. This finer level of detail for the threat sector will be discussed and a more detailed model presented before the linkages which restrict the military capabilities are added.

While there are some notable exceptions like electronic counter measures, there was general agreement, among those interviewed and in the literature, that the perceived threat which the United States faces does not

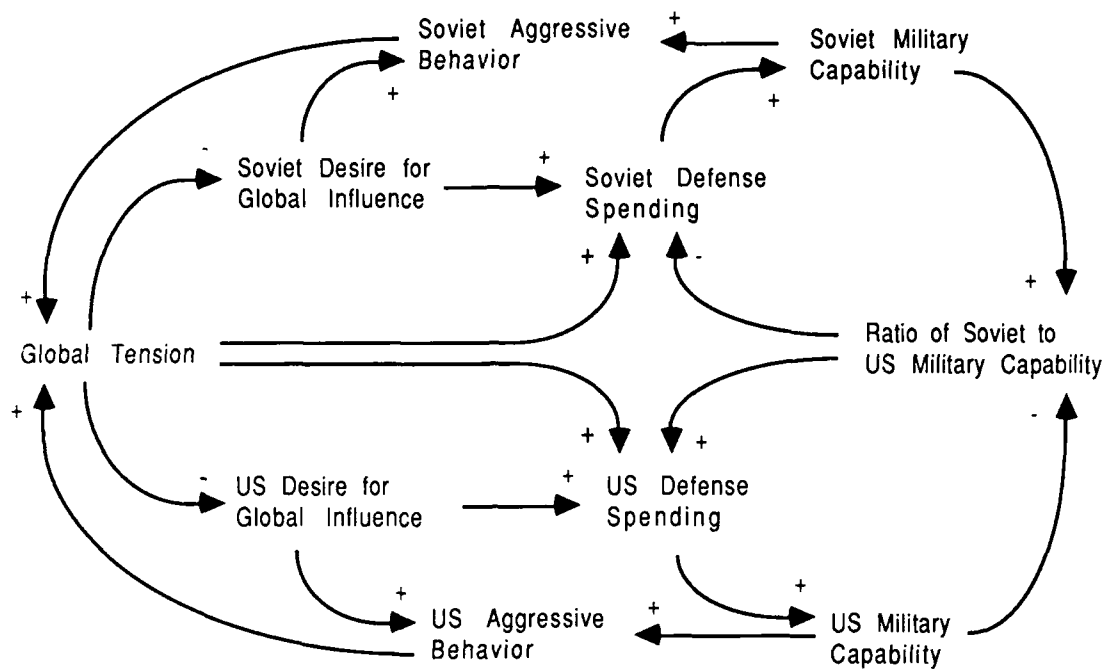

Figure 12. Global Tension Structure

seem to directly impact the acquisition of specific weapon systems, the number of weapons which are produced or the tradeoff of weapon quality for quantity (Brown and Korb 1983, Dyer 1985, Fallows 1981, Luttwak 1984). The perception is that the threat is used by the actors in the system to justify a given position on arms acquisition (Dyer 1985, Fallows 1981, Luttwak 1984). The result is that the weapons procurement process seems to be quite insulated from a direct threat influence and thus does not respond to individual threat capabilities. In reality, the process of detining a requirement for a weapon, designing the weapon, developing and producing it has become so lengthy that intelligence estimates a decade or more in advance are required. Intelligence

estimates of current capabilities are not completely accurate and estimates of capabilities ten years or more into the future contain much more uncertainty. Because of this inherent uncertainty, "perceived threat" and its determinant "perceived capability" were introduced into the model to accurately represent the actual threat reaction phenomena.

The threat sector model is basically symmetrical in structure, with respect to Soviet and United States military capability determination. The major exception is that the Soviet macroeconomic system was not modeled as it was for the United States in the national sector. The process by which the Soviets determine their level of defense spending has been effectively shielded from outside observation and this model only reflects the notion that defense spending by the Soviets affects the growth in Soviet gross domestic product (GDP) which in turn limits the Nation's long term ability to fund increased military purchases (Collins 1978). On the other hand, the budgeting process of the United States is observable and has a significant impact upon the efficiency of the weapon acquisition process. The budgeting process and a simple macroeconomic model of the United States' economy are presented in the national sector model in the next section.

Military capability for both the United States and the Soviets is a complex variable. It is determined by the level of defense expenditures in four distinct categories. Defense expenditures can 1) increase weapon technology, 2) produce larger weapons inventories, 3) increase readiness levels, or 4) can be

used to either increase ones own intelligence resolution or decrease the intelligence resolution of an adversary. Soviet weapon technology is impacted directly by the level of United States technology and its own intelligence resolution because of the transfer of technology, legal and otherwise, from the United States and other countries.

Because of faulty intelligence, incorrect analyses or biases in the threat assessment systems, the perception of the threat may differ from the actual threat stemming from military capability differentials. In both the Soviet Union and the United States, it is certainly the perceived threat which drives the desire for additional capability and not the actual capabilities which are unknown. The overstatement of threat capabilities is a common intelligence reaction to a demand for future threat assessments that has the unintentional impact of increasing the level of global tension and results in pressure on opponents to develop a capability to counter the capability which has been developed to counter an overstated threat capability (Dyer 1985). Just as in the requirements determination process in which the services take a conservative approach (it is presumed to be better to err on the side of overestimating requirements than the alternative), the intelligence community deals with the inherent uncertainties by tending to overestimate threats rather than underestimating them.

Increases in perceived capability differential lead to that country feeling less threatened, which reduces global tension, but also enables it to pursue a more aggressive international political agenda which can increase global

tensions. Perceived capability differential is based on a net assessment of the two superpower military capabilities and depends on the political agenda that the military capability is to support. If a country was intent on aggressive political action, it would necessarily view its own capabilities relative to those intentions. The net assessment also is impacted by the accuracy of the intelligence concerning the threats' capabilities.

The impact of intelligence functions and perception on the acquisition process was included in the model using the "intelligence resolution" and "perceived capability" variables. The additional variables and more detailed structure allowed the effects of biased threat assessments, technology transfer, counterintelligence strategies and perceived military capability to be represented. They also allowed for the determination of the impact of incomplete and inaccurate intelligence on the system's behavior. Adding this structure resulted in the more complex sector model shown in Figure 13. The "desire for global influence" variable was deleted at this more detailed level and was replaced by the political behavior variables which are shown to be interacting with each other and the global tension variable.

This level of detail allowed meaningful loop analysis that increased insight into how the system might behave under differing policy alternatives. For example, careful study of the loop structure showed that an excellent way to stabilize the arms race may be to have free and open inspection by both sides of each others capabilities. This is, of course, quite unlikely but the system's

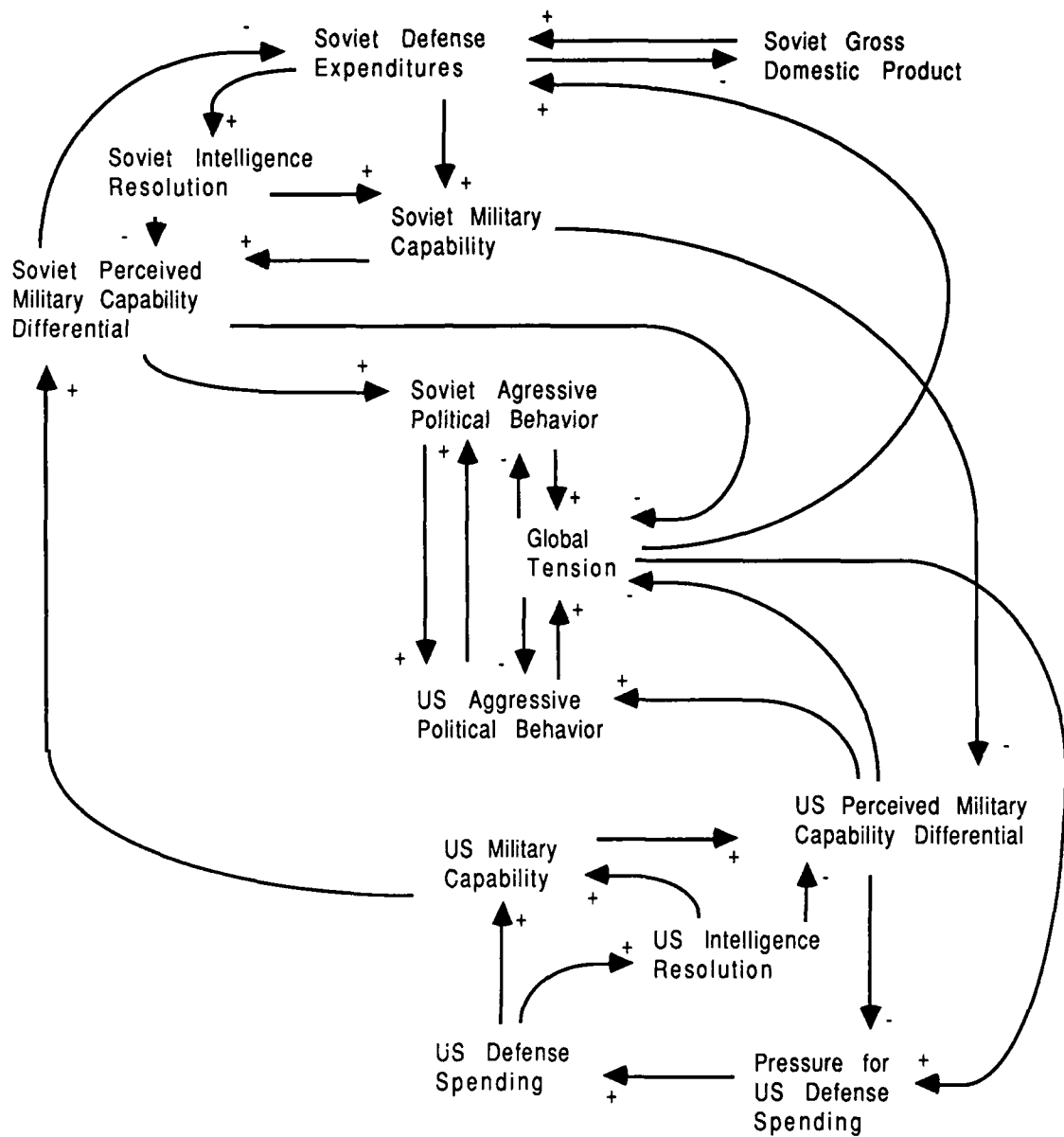

Figure 13. Threat Sector Complex Structure

structure as modeled would indicate that accurate information would reduce the rate of spending. Pressure for United States defense spending results not only from threat influences but also from domestic pressures and deficit pressures which tend to lower it. These influences are included in the national sector.

National Sector

Because defense spending levels are determined in a process where the political considerations of federal budgeting interact, a defense acquisition system model must include a representation of the effects of that process. Increased defense spending can have an important impact on national economic policies and long term economic growth. The purpose was not to model the United States economy or the budgeting process in great detail, but rather to represent their impact on the weapon acquisition process. The interactions of the national sector like those of the threat sector produce long-term effects on system behavior. The setting of national priorities through budgeting for national defense, entitlements, welfare payments and deficit reduction is represented in this sector. Economic theory related to the national budgeting process was used to represent a macroeconomic system which reflects the long-term impact of defense spending on the national economy as well as to generate the characteristic cyclical behavior in GNP growth.

The key loop in this sector reflects the significant political pressures

which relate current defense spending levels and the size of the budget deficit. The interactions among the key elements are shown in Figure 14. The variable, United States defense spending, introduced in the threat sector is the key link between the two sectors. As defense spending grows, the federal budget will increase and all things equal, so will the budget deficit. This growth in the deficit has produced increasing pressure to balance the budget by reducing spending. These forces are reflected in the figure.

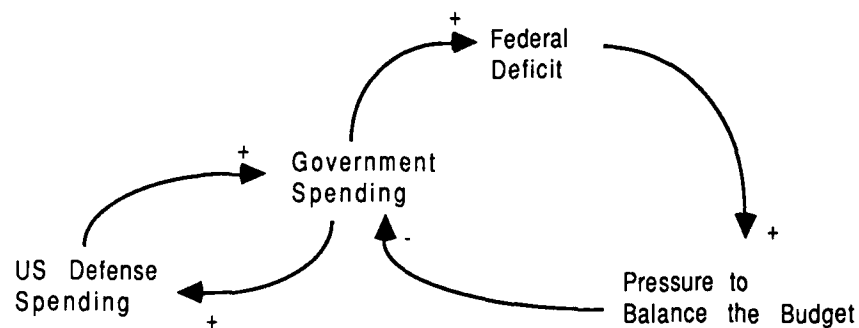

Figure 14. National Sector Basic Structure

The more detailed structure of the national sector was based on accepted, classical macroeconomic theory which postulates that national income (GNP), consumption, interest rates, government expenditures, investment and taxes are all linked together and can be modeled as a system of simultaneous equations. National income is affected positively by investment, consumption and government spending. Growth in GNP results in increased consumption stemming from higher incomes and in higher government

spending stemming from higher tax revenues. The countering force to these positive effects is the interest rate which, as it rises, acts to reduce investment and decrease consumption. The interest rate rises and falls depending on the relative positions of the money supply and money demand. As money demand rises due to increases in government borrowing or increases in investment, interest rates rise to attract more money. If money supply rises relative to the demand for money then interest rates drop which encourages borrowing. The model does not reflect the impact of inflation on these variables, but instead, the relationships shown are between the "real" values rather than the "nominal" values. These forces are shown in Figure 15.

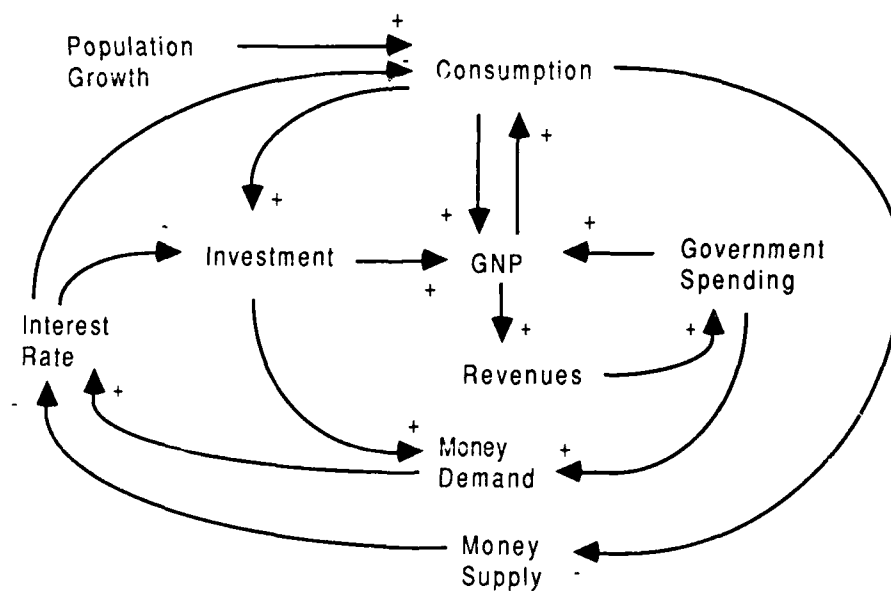

Figure 15. Spending and Investment Structure

Because of the expectation of increased profits from meeting expanding demand with expanded capacity, both employment and investment tend to rise with increases in consumption. When interest rates rise, consumption is replaced by savings as consumers delay purchases to take advantage of investment income opportunities, and investment becomes less desirable at the higher interest rates thus reducing the demand for money and bringing interest rates down toward some equilibrium position. This additional structure is represented in Figure 16.

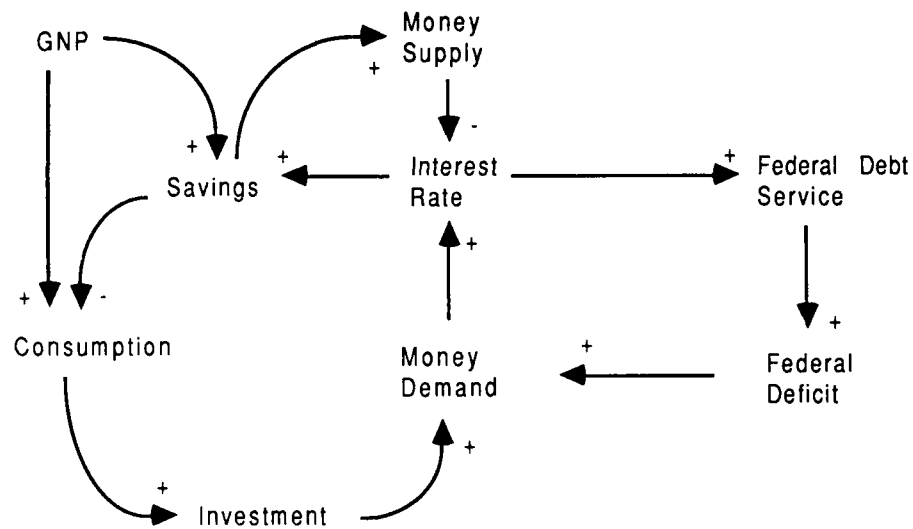

Figure 16. Savings and Money Supply and Demand Structure

A key element in the national sector is the size and rate of growth of the national debt which results from Federal spending deficits. There is considerable support for the idea that the national budgeting process does not make tradeoffs between defense and social spending directly, but that each

component is determined based on independent criteria (Stockman 1986, Stubbing 1986). The mediating variable seems to be the debt service component of the budget and the pressure to reduce the rate of increase in the national debt that is the annual Federal deficit. This structure is in agreement with the implications of the cybernetic paradigm of organizational decision making (Steinbruner 1974) which holds that complex tradeoffs tend to be avoided. An example is the defense buildup which took place between 1978 and 1984 which was not accompanied by significant reductions in social spending but rather by record deficits. Pressure to balance the budget is impacted by the annual budget deficit level. The pressure to reduce the budget deficit can result in either lower federal budget levels, increased revenues or both of these outcomes.

National priorities were assumed to be reflected by the federal budget funding levels. The three budget components reflected in the complex model of the sector shown in Figure 17 are: defense spending, debt service and all other spending. The other spending category is labeled "social spending" even though the label may not accurately reflect all that comprises this component. The important output of the national sector to the acquisition system is the defense spending level, so for the purpose of this research, it is not necessary to represent the national economy in any greater detail. Additional economic variables are included to capture the concepts discussed earlier. As discussed, the structure was well grounded in macroeconomic theory. It was not the intent

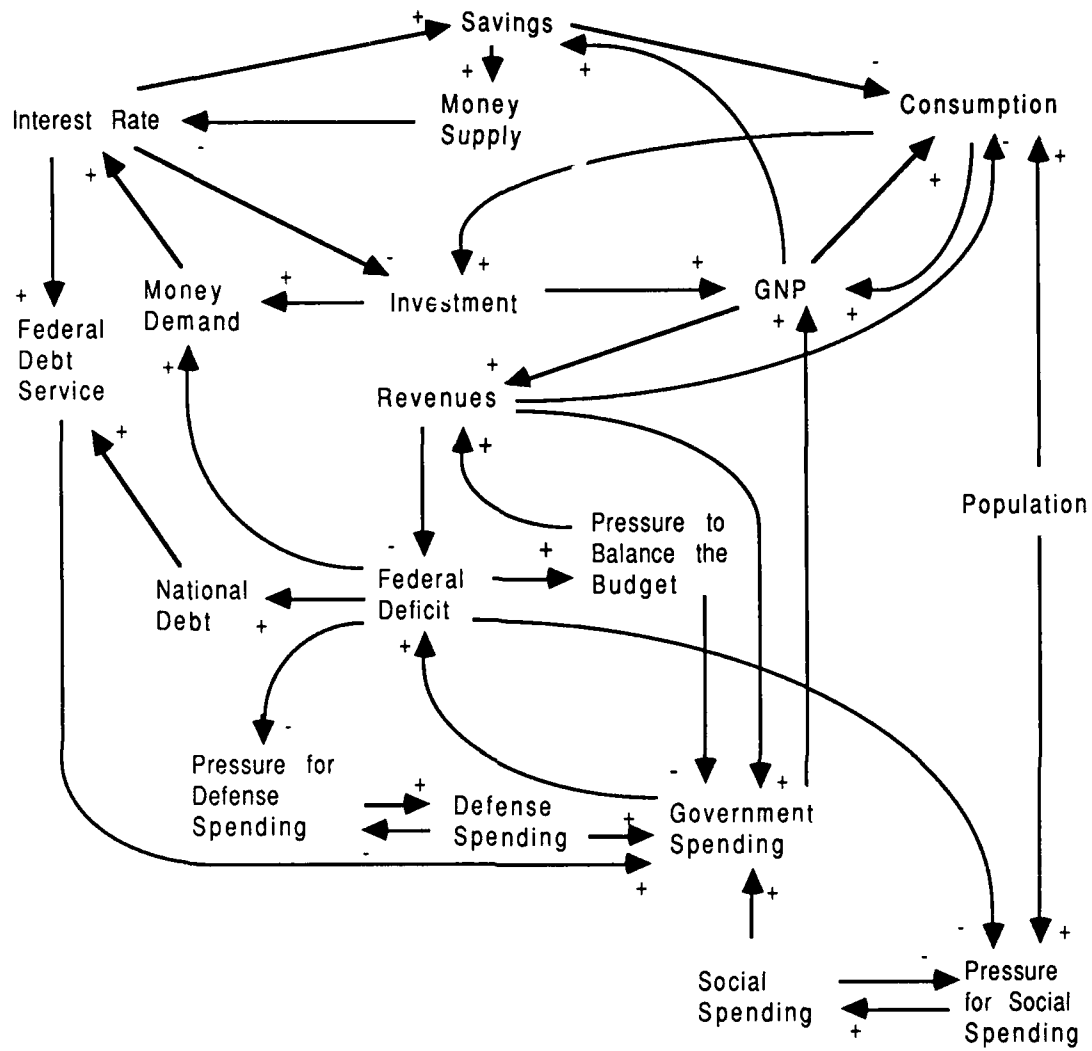

Figure 17. National Sector Complex Structure

of the model to explain the national economy, but simply to represent the influence of the current state of the economy on the acquisition process.

The defense sector integrates the budgetary constraint with the demands of the threat and determines how the funds will be spent and what the result is in terms of military capability. The defense sector is presented in the next section.

Defense Sector

Since the primary objective of this research was to provide a useful tool for policy analysis of defense acquisition, greater model detail and resolution was needed in the defense sector model. A second reason for providing additional detail in this sector was that most of the people interviewed believed that any successful restructuring of the acquisition system is more likely in this sector than the others. The defense sector structure determines, to a large degree, the behavior of the industrial sector and the effectiveness of the overall weapons acquisition system in terms of its ability to efficiently produce weapons (Coulam 1977, Fallows 1981, Gansler 1980, President 1986). The influences outside of the defense sector (threats to United States national security, national budgetary policies, and industrial policies) have an impact, but it is the interaction of the outside factors with the defense sector that has created much of the behavior which has been identified as being in need of reform (Fallows 1981, Gansler 1980, Stubbing 1986).

The defense sector was structured around the key relationships between the defense spending components: operations, maintenance and personnel (O&M/P); acquisition; research and development (R&D); and intelligence resolution. Expenditures in these categories result in the major systemic outputs of readiness, weapon inventory, technology produced, and intelligence resolution. These results of defense spending (readiness, weapon inventory, weapon technology, and intelligence resolution) determine the military capability of the United States which, when compared to the military capability of the Soviets, individually and collectively generates defense spending pressure. The interactions and processes of this sector, therefore, form a significant *positively reinforcing* structure that is a key element in overall system behavior. This basic structure, which will be expanded later, is shown in Figure 18. The development of the basic structure shown in Figure 18 will be pursued in the remainder of this section.

The strong *positively reinforcing* nature of increased defense spending can be seen clearly in Figure 18. There are no feedback elements shown and no negative forces represented. Of course, there are pressures to control spending, but they are exerted outside of the defense sector. The primary constraints come from the economic realities imposed in the national sector and the rising global tensions in the threat sector which would result from *unchecked defense spending*.

Priorities within the defense sector, like those in the national sector, are

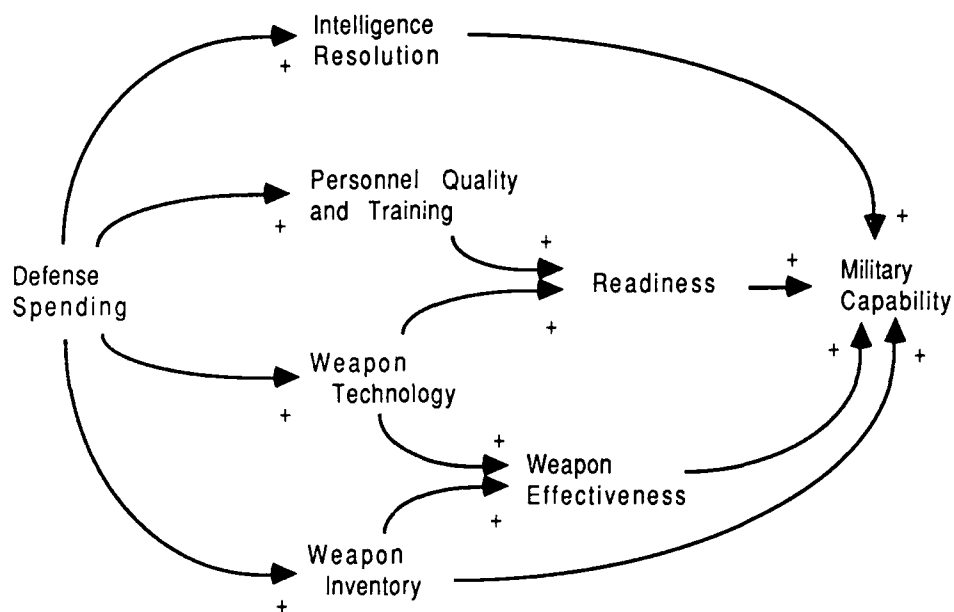

Figure 18. Defense Sector Basic Structure

best represented in the budget figures for different defense accounts. The defense budget was broken down into four separate accounts along threat lines rather than by service components as is done in the individual departmental budgets. This aggregation across services reflects the threat sector structure, where no service distinctions were made. The threat was comprised of four components, there was a near term component (Soviet readiness), a medium term component (Soviet weapon inventory), a long term component (Soviet weapon technology) and a Soviet intelligence resolution component which exerts influence in each time dimension. These spending categories, shown in Figure 19, and the capabilities that they yield will be discussed in detail.

The first component of the defense budget is the research and development (R&D) account. The purpose of R&D spending is the development of new weapon technologies which embody both "force multiplier" technology and "reliability and maintainability" technology. The first type of

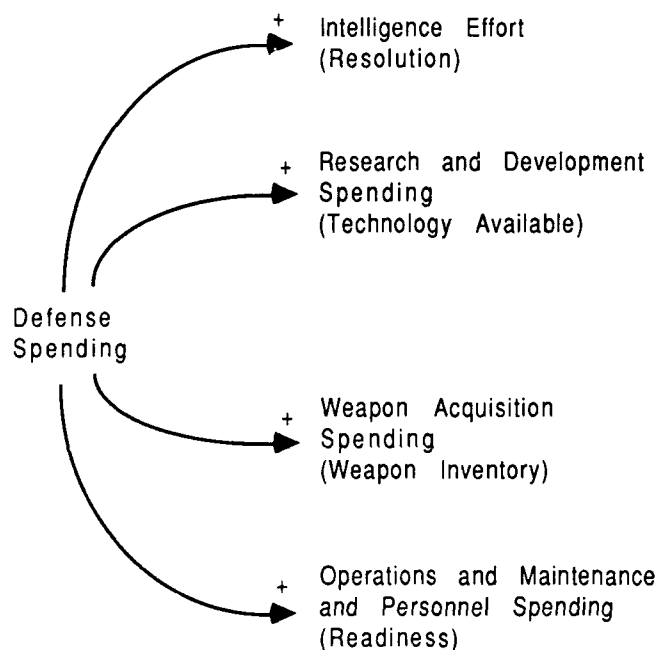

Figure 19. Defense Spending Categories

technology, force multiplier, increases the lethality of a given system and the second type, reliability and maintainability, affects its availability. The pressure to increase R&D spending comes from the current levels of weapon technology available, the current levels of weapon reliability and maintainability, and the technology level of Soviet weapons. Although comparison of available technology with Soviet technology should determine United States R&D spending requirements, the determination of the balance of forces in terms of

technology is not easy to make, so other factors often impact R&D spending levels.

Because weapon technologies that are developed are not always produced, a distinction between technology available and technology produced was made. The United States military depends on a technologically superior force, as a matter of policy, to overcome the numerical advantage that the Soviets have in many potential military confrontations. To some, it is this dependence on state of the art weapon technology that drives current acquisition policy and has led to rapidly escalating weapons costs (Fallows 1981, Luttwak 1984, Gansler 1980, Coulam 1977).

Although maintainability technology received much less attention than lethality technology development prior to the 1980's, its impact upon United States military capability can be significant because of the adverse impact that highly complex weapons can have on maintenance effectiveness and readiness (Fallows 1981). The employment of high technology weapons tends to increase the maintenance requirements initially, while the development and implementation of reliability and maintainability technology lowers it. The current operational readiness rates of the Air Force and Navy's most advanced fighter aircraft (in the 90% range after being below 50% only a decade ago) indicate the impact of increased emphasis on the reliability and maintainability issues.

The relationship between the number of systems developed and the

number of systems produced provides the check on R&D spending. Weapons cannot be acquired until they have gone through the development phase, so the number of weapons which have been developed places an upper bound on the number of systems which can be produced. Of course, pressure for weapons purchases and development will build up if too few weapons are being produced. These forces are shown in Figure 20.

The second component of the defense budget is the acquisition account. Pressure to increase the rate at which weapons are developed and acquired comes from a wide variety of sources including: the assessment of threat capabilities; the assessment of United States' weapon inventory and military capabilities; the technological age of the current inventory; and various political considerations. An increase in acquisition funding results in buying more weapons as well as stimulating the development and production of brand new weapons. The purchase of brand new weapons is dependent upon the availability of new designs resulting from previous R&D spending, so the production of new weapons as a result of a defense build-up usually lags other spending increases. The key relationships here include: the tendency for unit cost to go down as the number of units procured goes up, the number of units procured varies inversely with the number of different systems produced, and the increase in the length of time to develop and produce a weapon that comes with the larger number of weapons in production and development. These relationships are at the heart of the interaction between the R&D and

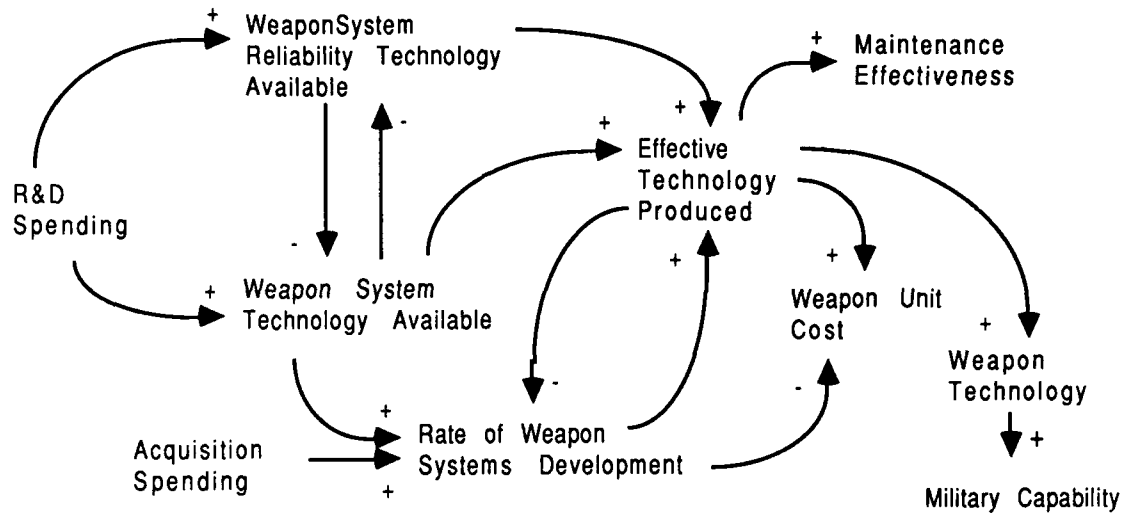

Figure 20. Research and Development Spending Structure

acquisition functions. The addition of acquisition spending is shown in Figure 21.

Shown in the figure are the key variables in the defense sector which impact the unit cost of weapon systems. They are the system development rate, the level of weapon technology produced, and the production period. The observation that longer development periods were leading to more expensive weapons led to the policy of concurrent development and production in the 1960's (Coulam 1977). In many cases, however, it was the lack of prototyping and effective testing and evaluation that led to extensive modification of weapons already in production and thus caused, in reality, longer development and much higher unit costs (Coulam 1977). The F-111 is perhaps the most notable example. Gansler (1980) noted that the technology produced also

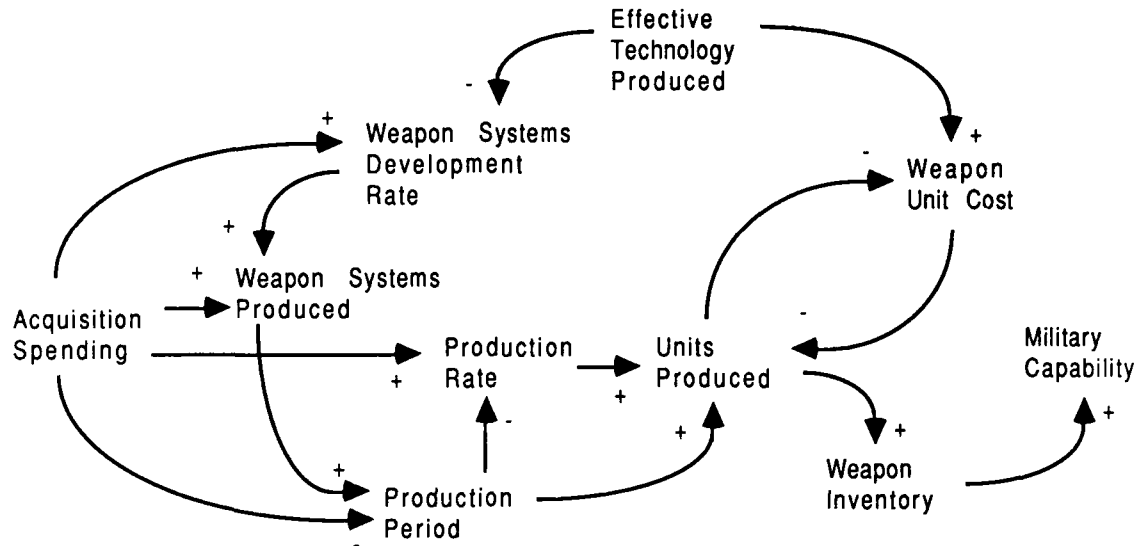

Figure 21. Acquisition Spending Structure

increased the lead time required by industry to produce the weapons which further lengthened the production period.

Fallows (1981) speculated that the desire for increased weapon capabilities was only partly due to the desire to offset the numerical disadvantage that the United States faces, but also was affected by the budgeting process. He observed that as soon as a firm number of weapons is agreed upon by the Department of Defense and the Congress, the services push to make them as capable as possible. Gansler (1980) identified similar pressures when he observed that the "hi-tech" work force that makes up the defense industry has a predisposition toward state of the art technology independent of any military requirements.

The third defense budget component, operations & maintenance and

personnel (O&M/P), includes spending for the procurement of spare parts, munitions and personnel training. This component typically is the most sensitive account to spending cuts (Foelber 1985) and is often the first account to be increased when spending levels increase (Fallows 1981). This probably is due to the nature of defense budgeting where acquisition outlays lag behind acquisition decisions, whereas O&M/P outlays are nearly all accomplished in the current year.

Increased stocks of spares and munitions directly increase readiness (Luttwak 1984), and the effectiveness of the maintenance function as less down time and cannibalization are necessary. Increased training also directly *increases readiness* as operations and maintenance effectiveness are increased (Luttwak 1984). At the same time, increased training also increases maintenance requirements, expenditures for spare parts and munitions, and results in the loss of some equipment. Pressure for increased O&M spending results from the *perceived level of readiness of the military, which is the result of O&M spending*, as well as the global tension variable, which is associated with a near term threat. These forces are shown in Figure 22.

The final component of the defense sector is the intelligence resolution. This component is presented in more detail in the threat sector. The presumption that the next superpower confrontation will be a "come as you are affair" (Brooks 1983, Dyer 1985) places great pressure on the strategic intelligence function which must provide early warning of conflict and assure

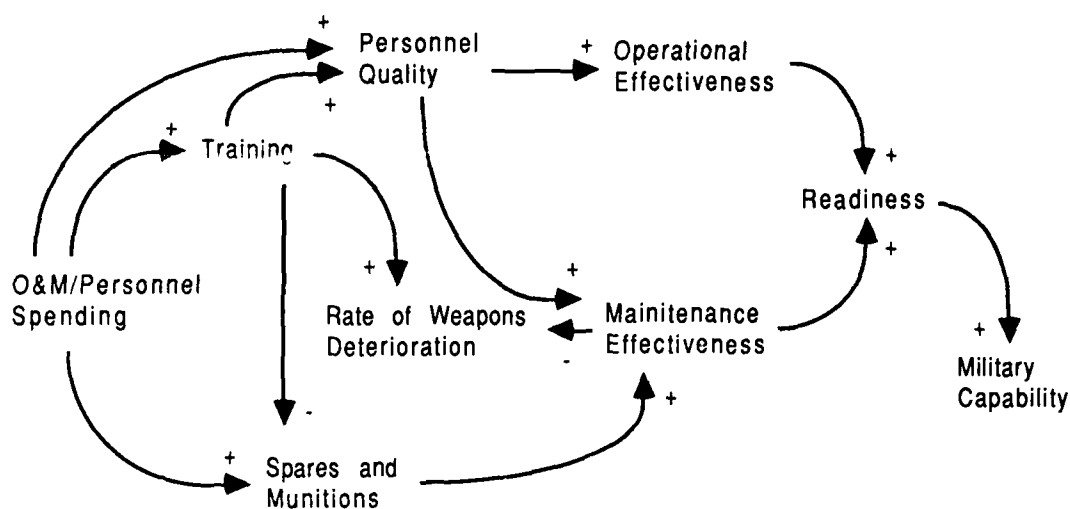

Figure 22. Operations and Maintenance/Personnel Spending Structure

proper development of forces. The resolution of the military intelligence function, therefore is a significant component of military capability. The intelligence components introduced in the discussion of the threat sector are shown in Figure 23, along with the other elements introduced earlier. Also shown in Figure 23 is the relationship between training, weapon deterioration and the weapon inventory. In the more complex diagram the training and weapon deterioration variables have been replaced by a single variable, "level of operations", in the interest of parsimony. As the level of military operations increases so does the level of personnel quality, due to the training effect. At the same time the weapon inventory is decreased due to weapon deterioration from the increased operations. The links to the industrial sector of the system also are shown in Figure 23. The number of weapon system units actually

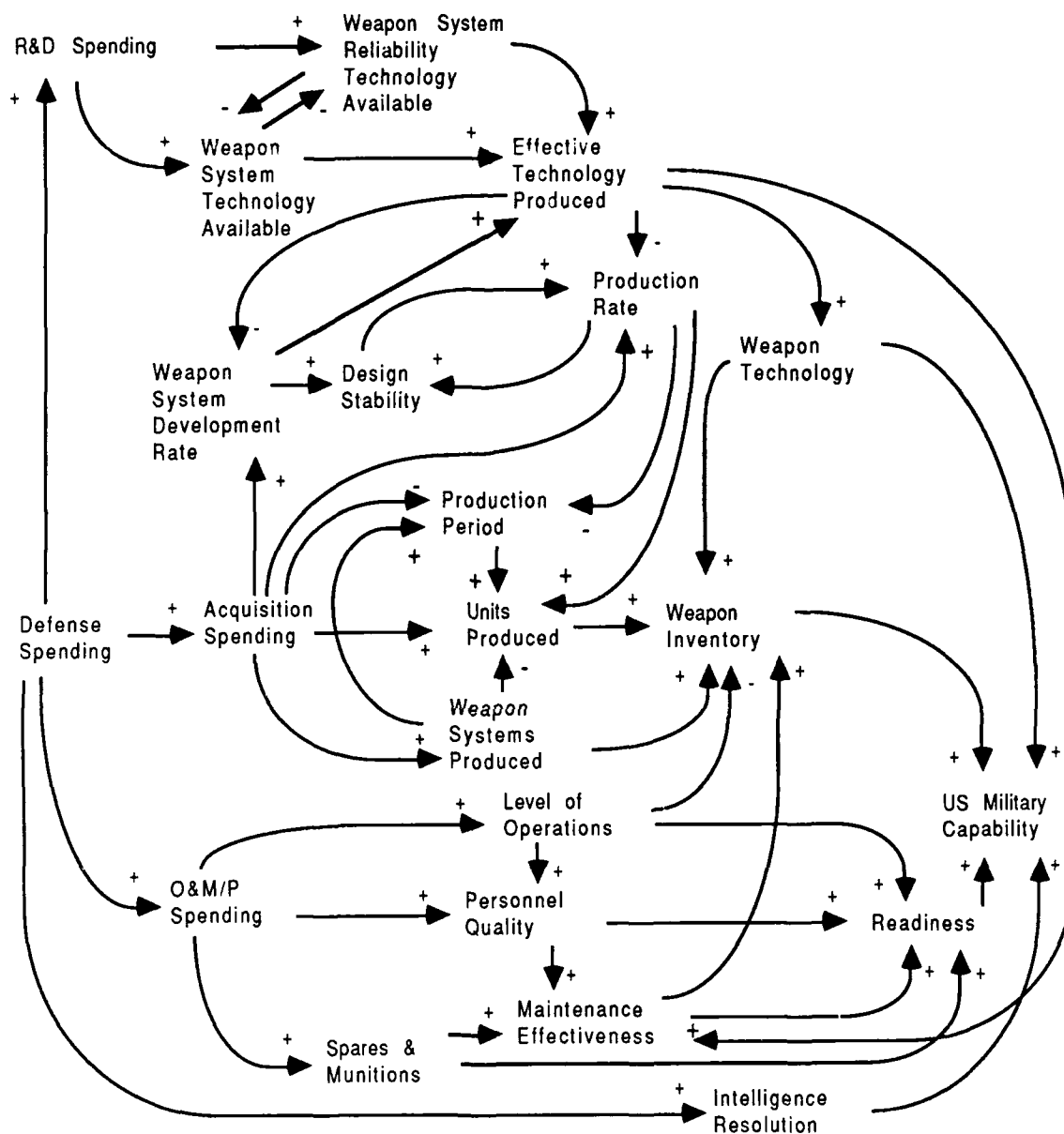

Figure 23. Defense Sector Complex Structure

produced and their costs become the focus of the industry sector, which is the subject of the next section.

Industry Sector

There are several excellent studies of the relationships between the national defense establishment and the United States' defense industry including: The Defense Industry (Gansler 1980), Arming America (Fox 1974), and The Weapons Acquisition Process (Peck and Scherer 1962). These studies, and others, provided the basis for the industrial sector structure presented in this section. The basic structure which has evolved in the defense industry is much the same as for any other industry but with some key differences. The important relationships which define the defense industry structure are contained in the capacity feedback loop, the unit cost feedback loop and their interactions which are shown in Figure 24. The "weapon unit cost" variable is the critical element that is determined in the industry sector and that provides the key linkage with the defense sector. Weapon unit cost, in this sense, is the cost to the Department of Defense and includes production cost and the contractors' profit. It is composed primarily of production costs which are influenced by the level of capacity utilization. Industrial capacity incorporates production technology and directly results from the industry's capital investment. Also adding to unit costs is the technology incorporated into a given weapon system.

firms perceive is presented in Figure 25. The use of foreign military sales and subsidies from the Department of Defense, in the form of bail outs and renegotiated contracts have been used to cover losses and reduce contractor risk in order to maintain the contractor base.

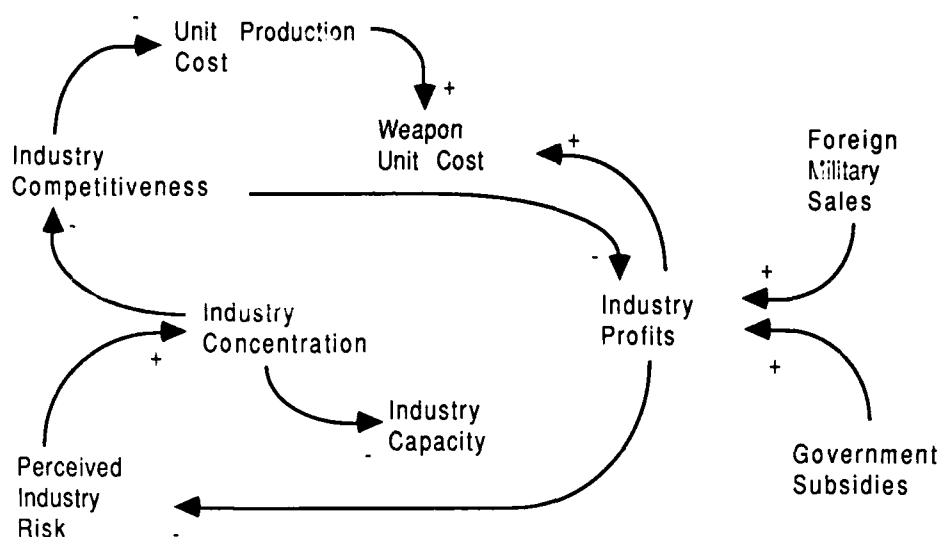

Figure 25. Industry Concentration and Competitiveness Structure

These basic economic structures exist in a highly charged political environment in which competing interests have various ideological and economic status. Political pressures from industry and other constituencies can be used to extend production runs, often at very low production rates, or to avoid cancellation of a given weapon system. The major impact of this politicizing of the acquisition process is that weapon systems are rarely cancelled resulting in longer production periods for the systems in production and in lower production rates. Long production periods in the past have

increased the pressure for concurrent production and development which tends to increase production costs because the design is modified during production. The B-1 bomber offers an excellent example of how political forces affect procurement actions (Kotz 1988). This structure is presented in Figure 26.

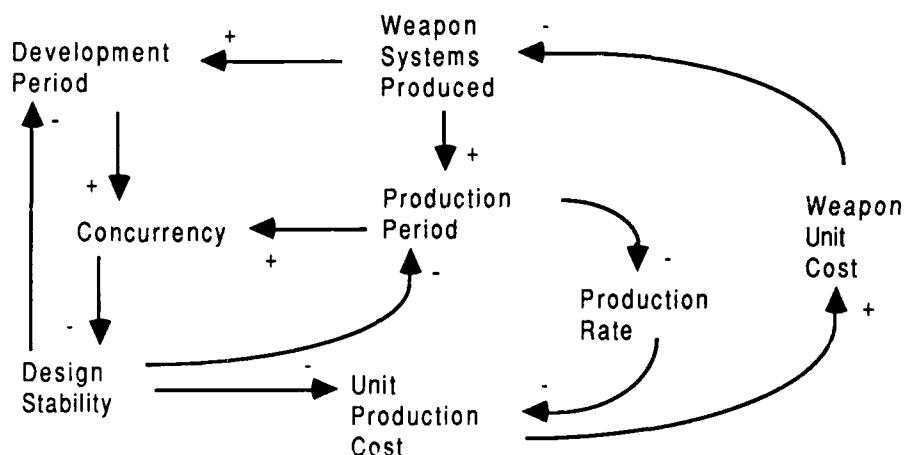

Figure 26. Development, Production and Cost Structure

Factors which contribute to the inability of contractors to meet contract requirements include: the uncertainty of estimating high-technology weapons costs, the tendency of the services to increase or resist the reduction of the capabilities requirements, and changing production schedules due to budget instability. The impact of these practices is that competitive economic forces are reduced and a different set of incentives replaces them.

The Department of Defense has followed a strategy where technology has for the most part been used to maximize the performance of individual weapon systems rather than to lower production costs and improve system

effectiveness simultaneously as is done more commonly in other industries (Gansler 1980). Although industry capital investment which could lower production costs has been the target of many incentive contracts in the past (Coulam 1977), only in the F-16 program (and similar programs) where a subsidy in the form of investment seed money was provided have firms invested heavily and effectively in capital equipment.

Much has been made of the low levels of investment by defense contractors (Gansler 1980, Barker and Konwin 1982), but this does not seem surprising from an industry where the natural competitive forces which would encourage investment in low-cost production capabilities have been negated by *increased risks for contractors*. The key factors affecting weapon system unit costs include: design and budget stability, the level of industry competition, production costs, the number of systems procured, overhead expenses, and the weapon technology produced. Capital investment by the industry would have the dual affect of lowering production costs at the same time as raising industry capacity and lowering capacity utilization. Lower capacity utilization, however, results in less pressure to invest in capital equipment. The feedback loop between industry capacity, capacity utilization and capital investment indicates that the overcapacity situation which exists at the prime contractor level, and is made worse by the government providing plants and equipment, must be addressed before a significant improvement in the investment practices of the prime contractors can occur.

The economic and political forces which shape the industrial sector are represented in Figure 27 along with the Department of Defense policy variables in a presentation of the complex system structure. The variables in the diagram capture the concepts discussed in this section.

Summary

The conceptual model which has been presented in this chapter was based on a review and analysis of the literature presented in Chapter 2 and the information gathered in the interviews described in Appendix A. The graphical conceptual models presented in this chapter have emphasized the structure of the weapon acquisition structure by concentrating on pair-wise interactions among system variables. The resulting system representations highlight the information feedback loops which exist in the real system.

The four interacting sectors which were modeled make possible their integration in a single simulation model based upon the structure identified in the conceptual modeling process. The level of detail of the complex sector models make their presentation in the form of an integrated model problematic. However the integration of the four sectors into a single simulation model which allowed for objective policy analysis and evaluations does not place the same demands on policy analysts. Instead the modeler alone is confronted with a simulation model's complexity. The conceptual models provide a good reference for discussions between the modeler and policy analysts concerning

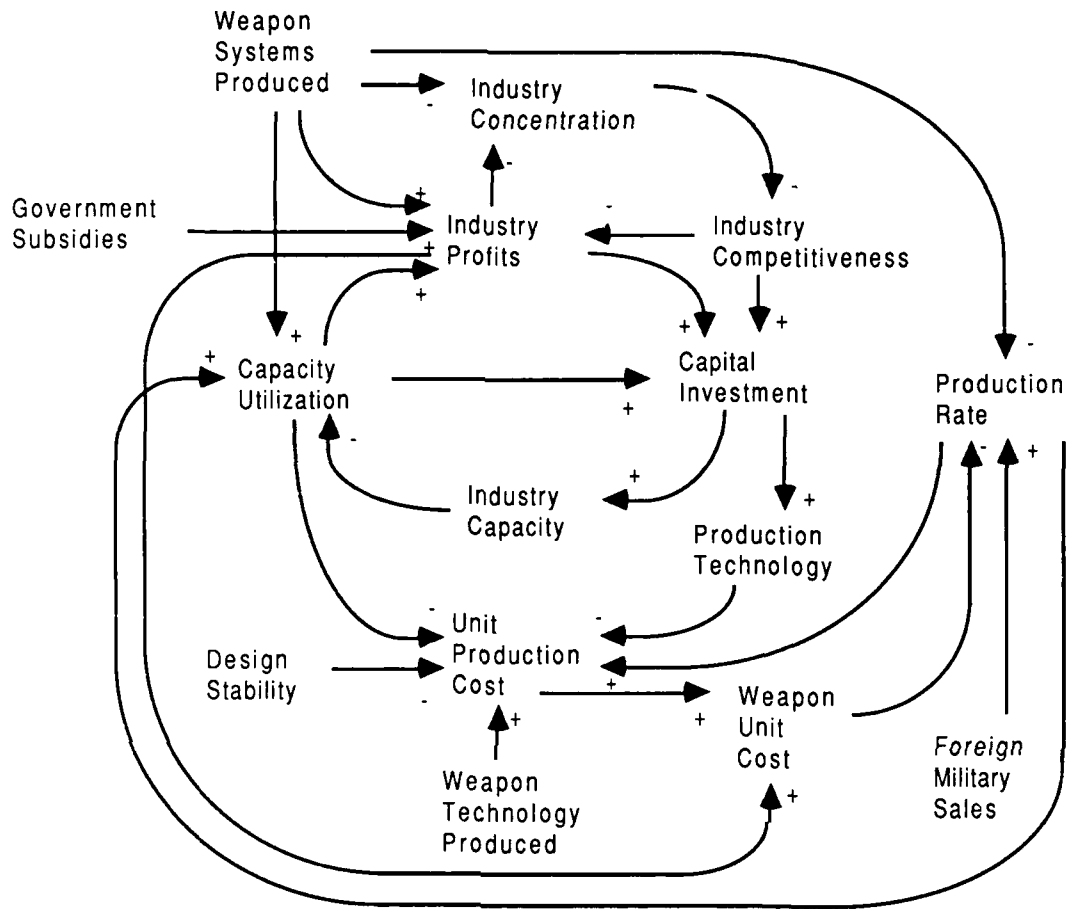

Figure 27. Industry Sector Complex Structure

policy alternatives and how the policies might be implemented in the model.

The simulation model which was developed based on the conceptual models presented in this chapter is presented in detail in the next chapter.

CHAPTER 5

PARAMETRIC MODEL

Introduction

The major emphasis of this research was the development of a model which can be used to perform policy analysis concerning the acquisition of major weapon systems. The conceptual model which was presented in Chapter 4 provided the conceptual basis for the parametric simulation model which is presented in this chapter. In the next chapter the validation process for the model described in Chapter 3 is discussed and a policy experiment is demonstrated as outlined in Chapter 1.

The parametric model which is presented in this chapter is a translation of the conceptual model presented in the previous chapter. The conceptual model was translated into a system dynamics (Forrester 1961) simulation model based on the process described in Chapter 3. The parametric model allows the impacts of the relationships identified in the conceptual model to be more readily observed. The simulation model provides the opportunity to compare policies in more than just a subjective manner. As with the conceptual model, the structure of the parametric model is open to scrutiny and discussion. Unlike the conceptual model, however, once a structure was agreed upon, quantitative

information resulting from the simulation model allowed for an objective validation of the model, objective policy comparisons, and objective evaluations of system behavior.

The output of the simulation model is composed of time series values of each variable included in the model. This enhances the ability of policy analysts to determine more fully the impact of time delays on the system's behavior. This was not possible using the conceptual model alone. The parametric model closely parallels the conceptual model upon which it is based. The same four sectors were modeled as interacting subsystems. The primary difference was the conversion of concepts and interrelationships into specific mathematical equations. The parametric model is more detailed than the conceptual model presented in Chapter 3, and therefore some new variables have been added to the model in order to operationalize the broad concepts included in the conceptual model.

Because of the macro level of perspective which has been taken with this research and the associated models, many of the variables represent aggregated concepts. A specific example of this is the notion of a weapon system. In the parametric model no distinction is made among types of weapon systems. Differences between the acquisition of the wide variety of weapon systems which are procured (tanks, aircraft, ships) have been ignored because the focus is not on individual weapon systems but the process of acquiring them. This aggregation of the system components and outputs created a

vehicle that should be used to evaluate system policies and not specific procurements of individual weapons. Another impact of aggregation is that the available data had to be aggregated in order to parameterize some of the relationships.

The initial conditions for the model were indexed to the year 1960. All dollar amounts in the model are in billions of 1960 dollars. Inflation was not modeled so all dollar amounts through time are constant 1960 dollars. In many cases, the choice for initial variable values was based on the need to generate observed dynamic system behaviors. Once one initial value was chosen, other values were often assigned based on their relative magnitude, and the effect on system behavior. This does not cause a problem because it was the dynamic trends in the variables which were concentrated on rather than the actual values (Forrester 1980, Starr 1980, Randers 1980). In the national sector most of the concepts have been used frequently in macroeconomic models and initial values were easily obtained from published data.

In the rest of this chapter, each of the four sector models is presented with a detailed explanation of the equations which constitute them. The equations which make up the model are presented in the same form as they appeared when ready for compilation with the DYNAMO compiler as specified in Richardson and Pugh (1981). The Dynamo code is in smaller type with an explanation of the variable names below each equation and an equation number at the right. The equations are numbered with a sector identifier

(T - threat, N - national, D - defense, I - industry) followed by the equation type (L - level, A - auxiliary, R - rate, T - table, N - initial level, C - constant term) followed by a number. For example, TA3 would indicate the third auxiliary equation in the threat sector.

Table functions which were used extensively are presented with a graphical presentation of the relationship and are numbered consecutively within a sector. The axes of the table functions are labeled with variable names, or functions of variables, and with the equation number which describes that variable. Table functions are an important aspect of system dynamics modeling as they allow for dynamic, nonlinear relationships to be modeled between a variable dependent upon one or more independent variables. The table functions allowed the system model to change its behavior based on some aspects of the state of the system. This is the basis for the dynamic nature of systems (Forrester 1961).

Threat Sector

The threat sector model includes the variables which interact to generate the arms race and the variables that place the same fiscal limitations on Soviet defense spending as the national sector model places on the United States. While parameter values for most Soviet variables have been taken from Lee's respected references "Soviet Defense Expenditures" (1976) and The Estimation of Soviet Defense Expenditures 1955-1975 (1977), very little about Soviet

defense expenditures in dollar terms actually is known with certainty. As a result some of the parameters which appear in the model have been chosen in relation to United States values to ensure compatible comparisons and an initially stable system. The structure of the threat sector model is presented in the modified flow diagram of Figure 28 in the form described in Richardson and Pugh (1981). Each of the variables shown will be explained in subsequent discussion.

Annual Soviet defense expenditures (SDE) are determined by multiplying the Soviet defense share of the Soviet gross domestic product (SDGP) by gross domestic product. The share of Soviet GDP which is allocated to defense is determined by the Soviet's perception of the military capability differential (SPMCD) with the United States. The greater the imbalance, the greater the share of the GDP allocated to defense. The initial level of Soviet GDP applied to defense is 9% (Lee 1976, 265). The rate of increase is limited to ten percent of the current level per year and a maximum level of 17% which also corresponds with the data in Lee (1976, 1977). This relationship is shown in Figure 29 where the rate of increase from the table function is multiplied by the difference between the current defense share and the maximum level of 17%.

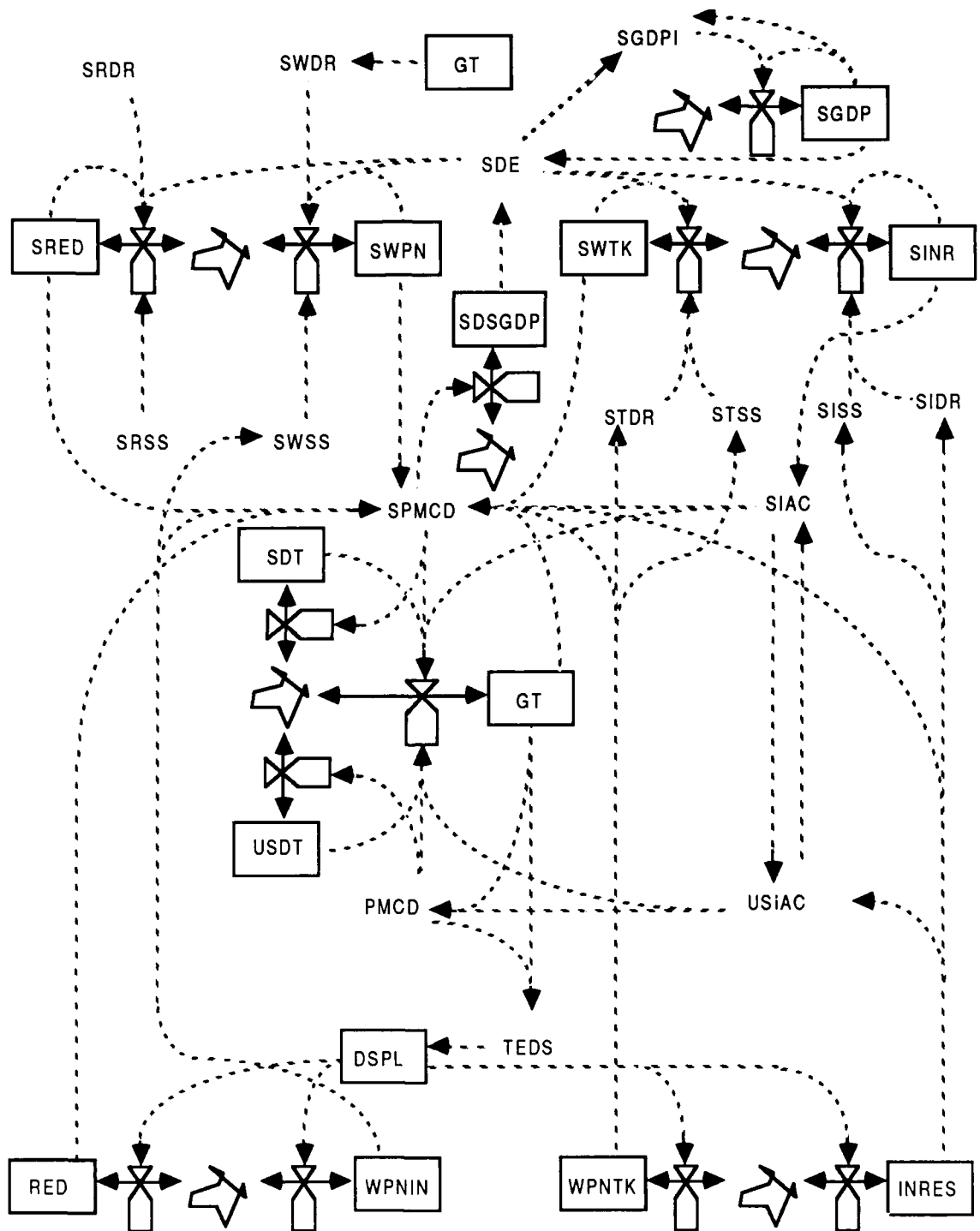

Figure 28. Threat Sector Modified Flow Diagram

Table 1. -- Figure 28 Key

VARIABLE	NAME	MEASURE
DSPL	Defense Spending Level (US)	\$ billion/year
GT	Global Tension	global tension units
INRES	Intelligence Resolution (US)	\$ billion
PMCD	Perceived Military Capability Difference	\$ billion
RED	Readiness (US)	\$ billion
SDE	Soviet Defense Expenditures	\$ billion/year
SDSGDP	Soviet Defense Share of GDP	%
SDT	Soviet Desired Tension	global tension units
SGDP	Soviet Gross Domestic Product	\$ billion/year
SGDPI	Soviet GDP Increase	% change/year
SIAC	Soviet Intelligence Accuracy	dimensionless
SIDR	Soviet Intelligence Depreciation Rate	years
SINR	Soviet Intelligence Resolution	\$ billion
SISS	Soviet Intelligence Spending Share	%
SPMCD	Soviet Perceived Military Capability Difference	\$ billion
SRED	Soviet Readiness	\$ billion
SRSS	Soviet Readiness Spending Share	%
STDR	Soviet Technology Depreciation Rate	years
STSS	Soviet Technology Spending Share	%
SWDR	Soviet Weapon Depreciation Rate	years
SWPN	Soviet Weapon Inventory Level	\$ billion
SWSS	Soviet Weapon Spending Share	%
SWTK	Soviet Weapon Technology Level	\$ billion
TEDS	Threat Effect on US Defense Spending	% change/year
USDT	US Desired Tension Level	global tension units
USIAC	US Intelligence Accuracy	dimensionless
WPIN	Weapon Inventory Level (US)	\$ billion
WPNTK	Weapon Technology Level (US)	\$ billion

A $SDE.K = SDSGDP.K * SGDP.K$ TA1
 Note Soviet Defense Expenditures (\$ billion/year)
 L $SDSGDP.K = SDSGDP.J + (DT * SDSRC.JK)$ TL1
 N $SDSGDP = .09$
 Note Soviet Defense Share of Gross Domestic Product (%).
 R $SDSRC.KL = SDSGDP.K * SPCEDS.K * (.17 - SDSGDP.K)$ TR1
 Note Soviet Defense Share Rate of Change (%/year).
 A $SPCEDS = TABHL(TSDS, SPMCD.K, -200, 200, 100)$ TA2
 T $TSDS = 1, .25, 0, -.12, -.6$ TT1
 Note Soviet Perceived Capability Effect on Defense Share (% change/year).

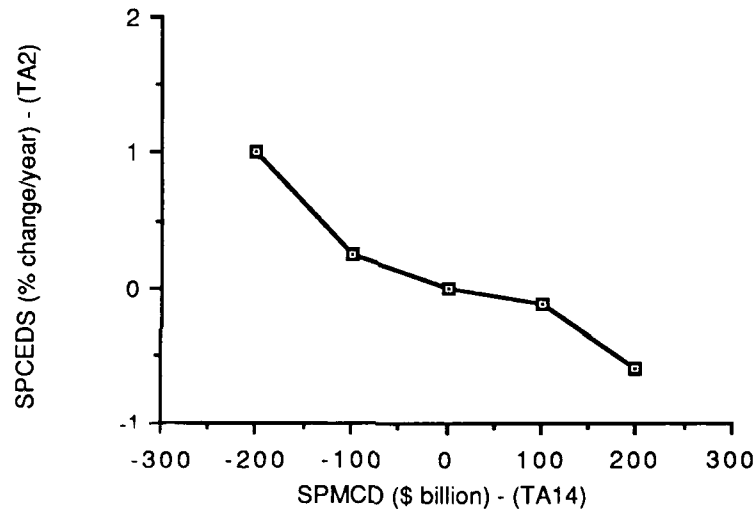

Figure 29. Structure of Soviet Defense Share of GDP

Soviet GDP increases at an annual rate which is partially dependent upon the level of Soviet defense spending. The more of Soviet GDP which is allocated to defense the slower the rate of GDP growth. This is shown in Figure 30. The table indicates a maximum growth rate of the Soviet economy of 3.5% per year with a minimum growth rate of two percent per year. The initial level of Soviet GDP (\$215 billion) and the annual growth rates were derived from Lee (1976, 1977) using his estimation of Soviet GDP in rubles multiplied by an

approximate rubles to dollar conversion rate (1:1.2).

L	$SGDP.K=SGDP.J+DT*SGDPRC.JK$	TL2
N	$SGDP=215$	
Note	Soviet Gross Domestic Product (\$ billion).	
R	$SGDPRC.KL=SGDP.K*SGDPI.K/3$	TR2
Note	Soviet GDP Rate of Change (\$ billion/year).	
A	$SGDPI.K=TABHL(TSGDP,SDE.J/SGDP.J,.09,.15,.01)$	TA3
T	$TSGDP=.035,.034,.031,.026,.023,.021,.02$	TT2
Note	Soviet GDP Increase (%).	

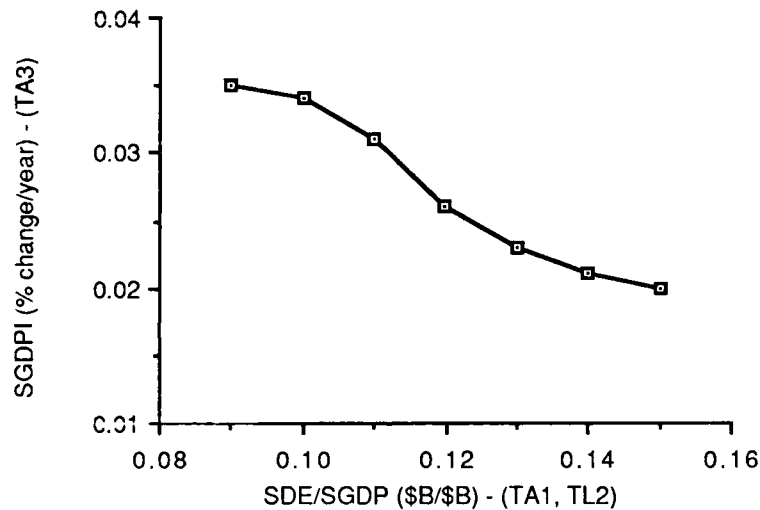

Figure 30. Structure of Soviet GDP Increase Rate

Both the United States' and Soviet military capabilities are composed of four individual components: readiness, weapon inventory, weapon technology, and intelligence resolution. The determination of each of these components for the United States is detailed at length later in the defense sector model. In the case of the Soviets, the component capability levels are a direct result of the amount of money that is spent. The greater level of detail in the defense sector model does not translate every dollar spent on weapons acquisition into an

additional dollars worth of inventory; therefore a spending efficiency factor has been added in the threat sector to reflect this for the Soviets. A spending efficiency in the Soviet readiness category of .4, or 40% efficiency, was used because it is close to the effective efficiency of the United States realized in the defense sector of this model and thus maintains some balance in the model. The rate of increase for each of the Soviet's military components is determined by the components' share of the defense expenditures. Except in the case of readiness, the component shares of the annual expenditures are determined by the perceived difference between the Soviet and United States component capability levels. For both the United States and the Soviet Union, the readiness account is determined as a result of the other shares.

Each of the component capability levels declines over time due to depreciation. Each component capability depreciates or depletes at a different rate. If the depreciation rate is ten years for readiness then in each year ten percent of the readiness level will be depleted. An initial level of readiness of \$15 billion was chosen in conjunction with a two year depreciation period because the initial annual readiness expenditures would sustain that level of readiness. The two year depreciation rate reflects the relatively fast rate at which personnel attrition occurs and the degree to which persistent training is required to maintain personnel readiness.

L	$SRED.K = SRED.J + (DT * SRRC.JK)$	TL3
N	$SRED = 15$	
Note	Soviet Military Readiness Level (\$ billion).	
R	$SRRC.KL = (SRSE * SRSS * SDE.K) - (SRED.K / SRDR)$	TR3
Note	Soviet Readiness Rate of Change (\$ billion/year).	
C	$SRSE = .4$	
Note	Soviet Readiness Spending Efficiency (%).	
C	$SRDR = 2$	
Note	Soviet Readiness Depletion Rate (years).	
A	$SRSS.K = 1 - SWISS.K - SWTSS.K - SISS.K$	TA4
Note	Soviet Readiness Spending Share (%).	

The Soviet weapon inventory level (SWPN) is a sum of the Soviet expenditures for weapons acquisition. The initial value of the Soviet weapon inventory was chosen based on a depreciation period of 25 years and annual effective expenditures in 1960 of \$4 billion. Weapon inventory depreciation rates are determined by the level of global tension, which measures the level of military activity. As military operations increase along with global tension levels the the rate at which weapon systems are used up increases. This could be due to either attrition in combat and training or the systems just wearing out more quickly with increased use. The relationship is shown in Figure 31. The global tension index, described more fully below is defined between zero and one hundred. A global tension level of zero corresponds to a total lack of hostilities world wide while a level of 100 corresponds to world war. The table indicates that as global tension increases the useful life of weapon inventories gets smaller. At a global tension level of 100, world war, the whole inventory is depleted in six months (Dyer 1985).

L	$SWPN.K = SWPN.J + (DT * SWIRC.JK)$	TL4
N	$SWPN = 100$	
Note	Soviet Weapon Inventory (\$ billion).	
R	$SWIRC.KL = (SPE * SWE.K * SWTM.K) - (SWPN.K / SWDR.K)$	TR4
Note	Soviet Weapon Inventory Rate of Change (\$ billion/year).	
C	$SPE = .6$	
Note	Soviet Production Efficiency (%).	
A	$SWE.K = SWISS.K * SDE.K$	TA5
Note	Soviet Weapon Expenditures (\$ billion/year).	
A	$SWDR.K = TABHL(TSWD, GT.K, 0, 100, 20)$	TA6
T	$TSWD = 50, 30, 25, 20, 10, .5$	TT3
Note	Soviet Weapon Depletion Rate (\$/year).	

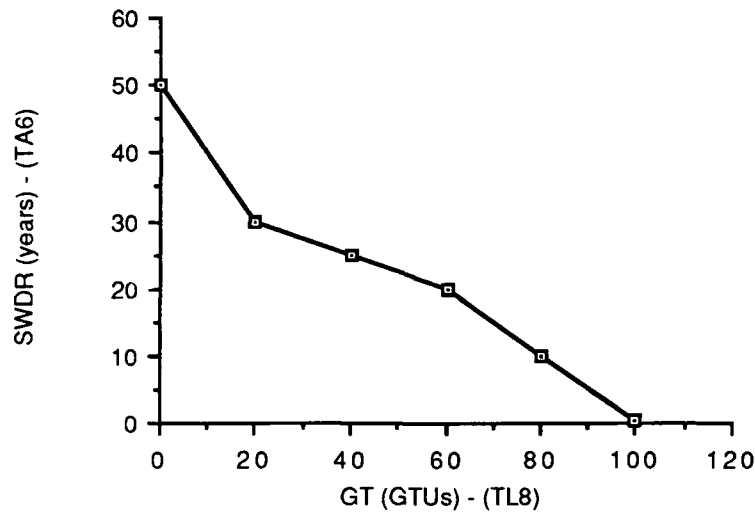

Figure 31. Structure for Soviet Weapon Depletion Rate

Perceived levels of United States weapon inventories which are compared to Soviet levels to determine Soviet weapon acquisition spending share are based on actual United States weapon inventory levels (WPNIN) and Soviet intelligence accuracy (SIAC). Intelligence accuracy is a dynamic multiplier which can result in either over estimations or under estimations of the opponents capability levels. The relationship shown in Figure 32, indicates a maximum share of 50% and a minimum share of 30% going to weapon

acquisition. When the Soviets perceive a weapon inventory ratio of one the share is 37%. These figures correspond to those found in Lee (1977,117).

A SWISS=TABHL(TSWS,SWPN.K/(SIAC.K*WPIN.K),0,2,.5)

T TSWS=.5,.41,.37,.34,.3

Note Soviet Weapon Inventory Spending Share (%).

TA7

TT4

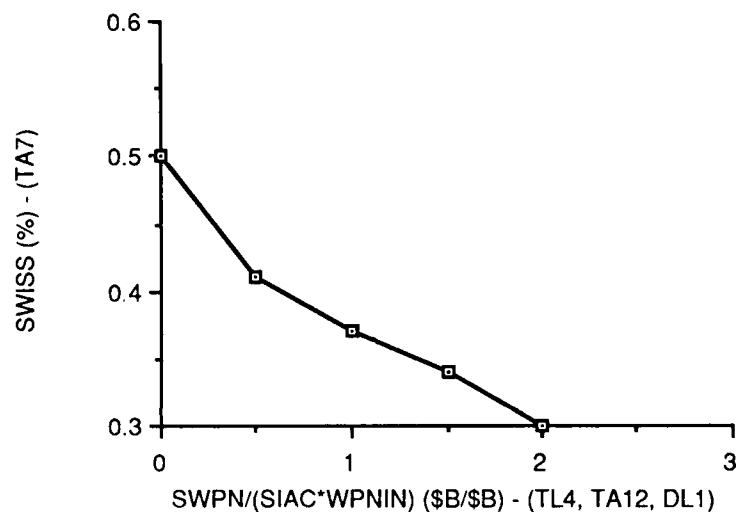
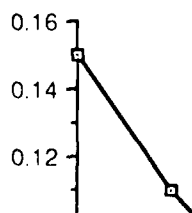

Figure 32. Structure of Soviet Weapon Inventory Spending Share

The second component of Soviet military capability is weapon technology (SWTK). The ratio of Soviet to United States weapon technologies determines the magnitude for a weighting factor used with the United States weapon inventory level. In cases where the technology levels are equal, additions to the United States weapon inventory are not modified. When the United States weapon technology level exceeds the Soviet level, additions to the United States weapon inventory are multiplied in value dependent upon on how big a difference exists. This reflects the impact of higher levels of

technology which are embedded in American weapons due to a greater reliance on weapon quality rather than quantity. The share of the defense expenditures which is applied to weapon technology is determined by the perceived technology ratio, that is the actual ratio modified by a factor for Soviet intelligence accuracy. This same structure is used throughout the model for operationalizing perceptions concerning military capability that was discussed in Chapter IV. The relationship, shown in Figure 33, indicates a maximum spending share for technology of 15% and a minimum level 5%. This range of values corresponds to those found in Lee (1977, 117). The initial level of Soviet weapon technology of six billion dollars is based on effective annual expenditures of two billion dollars and an initial depreciation period of about three years which reflects the technological disadvantage relative to the United States in 1960.

L	$SWTK.K=SWTK.J+(DT*SWTRC.JK)$	TL5
N	$SWTK=6$	
Note	Soviet Weapon Technology (\$ billion).	
R	$SWTRC.KL=(STE*SWTSS*SDE.K)-(SWTK.K/SWTDR.K)$	TR5
Note	Soviet Weapon Technology Rate of Change (\$ billion/year).	
C	$STE=.6$	
Note	Soviet Technology Efficiency (%).	
A	$SWTSS=TABHL(TSWTS,SWTK.K/(SIAC.K*WPNTK.K),0,2,.5)$	TA8
T	$TSWTS=.15,.11,.08,.06,.05$	TT5
Note	Soviet Weapon Technology Spending Share (%).	



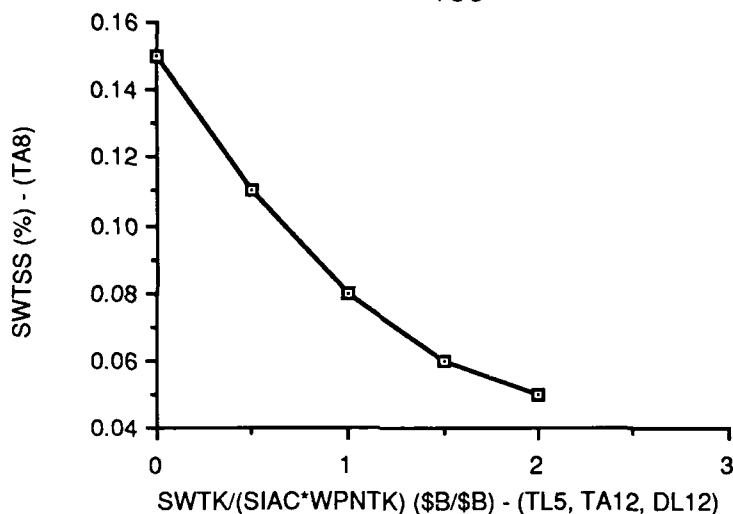

Figure 33. Structure of Soviet Technology Spending Share

The weapon technology levels, for both the United States and the Soviets, are relative values that must be viewed in relation to one another. While weapon technologies grow continually in the absolute sense, it is the relative levels of technology that are important to defense policy makers. Technology depreciation rates will be relatively short, between three and five years, which places an emphasis on current research and development spending. This also reflects the rapid technological advances made in weaponry and the way in which some technologies can be made obsolete very quickly either through tactical or technical innovation. In order to create a structure which behaves as if advances in weapon technologies are often aimed at specific technologies which an opponent develops; the rate of technology depletion was modeled as a function of the ratio of actual technology levels. The relationship between weapon technology ratio and Soviet technology depreciation is shown in

Figure 34.

A $SWTDR.K = TABHL(TSTD, SWTK.K / WPNTK.K, 0, 2, 5)$
 T $TSTD = 3, 3.7, 4, 4.3, 5$
 Note Soviet Weapon Technology Depletion Rate (years).

TA9
 TT6

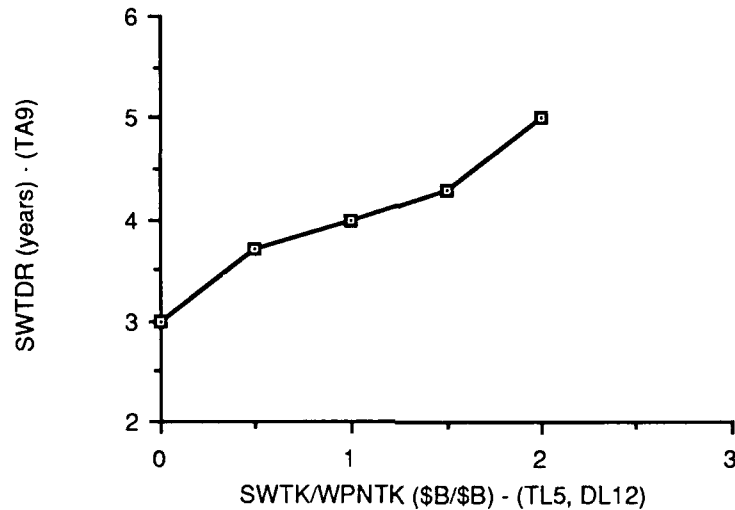

Figure 34. Structure of Soviet Weapon Technology Depletion Rate

The level of Soviet intelligence resolution (SINR) is increased by annual expenditures and decreased by a depreciation rate which is dependent upon the ratio of the two superpower's intelligence resolution. As the Soviet's level of intelligence resolution increases relative to the United States' level the Soviet's are more able to distort the United States' intelligence using counter-intelligence measures. This distortion resulting from increasingly effective counter-intelligence activity is operationalized as a faster depreciation of the opponent's level of intelligence resolution. The initial level of Soviet intelligence resolution of six billion dollars is based on approximately two billion

dollars annual expenditures and a three year depreciation rate, which reflects initial parity among the superpower intelligence functions. The share of defense expenditures allocated to the intelligence role is dependent upon the perceived ratio of intelligence resolution and is shown in Figure 35. The table function indicates a slower rate of change around a perceived ratio of one with faster changes at more extreme ratios, with a maximum spending level of 12% and a minimum level of eight percent.

Very little information is available for either the Soviets or the United States concerning intelligence budgets. The United States figures are estimations based on information available in the United States Air Force Summary 1986. Soviet values were chosen to match the United States values. The 70% intelligence spending efficiency is slightly higher than that of the United States because the collection of intelligence is somewhat easier in the United States for the Soviets than it is for the United States to collect intelligence in the Soviet Union.

L	$SINR.K = SINR.J + (DT * SINRR.JK)$	TL6
N	$SINR = 9$	
Note	Soviet Intelligence Resolution (\$ billion).	
R	$SIRRC.KL = (SISE * SISS.K * SDE.K) - (SINR.K / SIDR.K)$	TR6
Note	Soviet Intelligence Resolution Rate of Change (\$ billion/year).	
C	$SISE = .7$	
Note	Soviet Intelligence Spending Efficiency (%).	
A	$SISS.K = TABHL(TSIS, SINR.K / INRES.K, 0, 2, .5)$	TA10
T	$TSIS = .12, .105, .1, .095, .08$	TT7
Note	Soviet Intelligence Spending Share (%).	

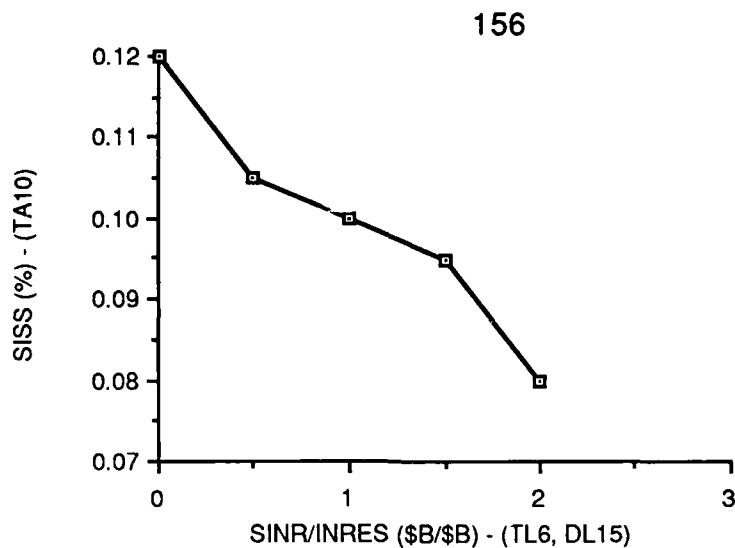

Figure 35. Structure for Relative Intelligence Resolution Effect on Soviet Intelligence Spending

The depletion of Soviet intelligence resolution is dependent upon the actual ratio of the superpower intelligence resolutions. This reflects the ability of each superpower to utilize their intelligence communities either to gather information or to disrupt the other's capability through counter-intelligence efforts. As the ratio of Soviet to United States intelligence resolution gets smaller, the intelligence resolution of the Soviets depletes more quickly, and as the ratio increases, it is depleted less quickly. This relationship is shown in Figure 36. The depreciation period ranges between two and four years which reflects not only the dynamics of the components of military capability but also the dynamics of the political environment. Intelligence about political intentions is extremely important and subject to rapid change.

A SIDR.K=TABHL(TSID,SINR.K/INRES.K,0,2,.5)

T TSID=2,2.7,3,3.3,4

Note Soviet Intelligence Depletion Rate (years).

TA11

TT8

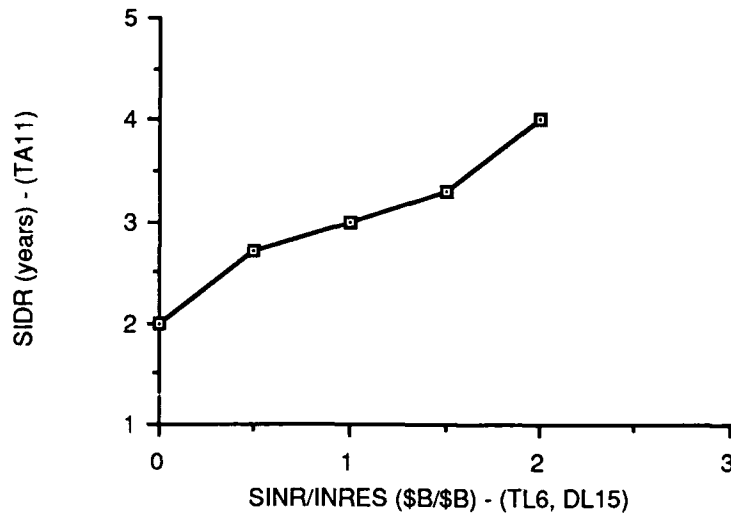

Figure 36. Structure of Soviet Intelligence Resolution Depletion

The Soviet intelligence accuracy multiplier (SIAC) is modeled as a function of the ratio of the intelligence resolution levels and includes a constant 10% overestimation bias which results from projecting estimates forward in time. The further into the future that intelligence estimates are extrapolated, in order to predict future threat capabilities, the less is the confidence in the estimates and the greater the tendency to overestimate threat capabilities. The relationship is shown in Figure 37, and indicates a larger accuracy figure when the Soviets have a lower resolution level than the United States. The larger accuracy figure reflects the higher level of uncertainty which corresponds to a lower relative intelligence resolution.

A $SIAC.K=1+SBIAS*SAMP.K$

TA12

Note Soviet Intelligence Accuracy Multiplier.

A $SAMP.K=TABHL(TSIAC,SINR.K/INRES.K,0,2,.5)$

TA13

T $TSIAC=2,1.3,1,.9,.85$

TT9

Note Soviet Intelligence Accuracy Amplifier.

C $SBIAS=.1$

Note Soviet Intelligence Bias.

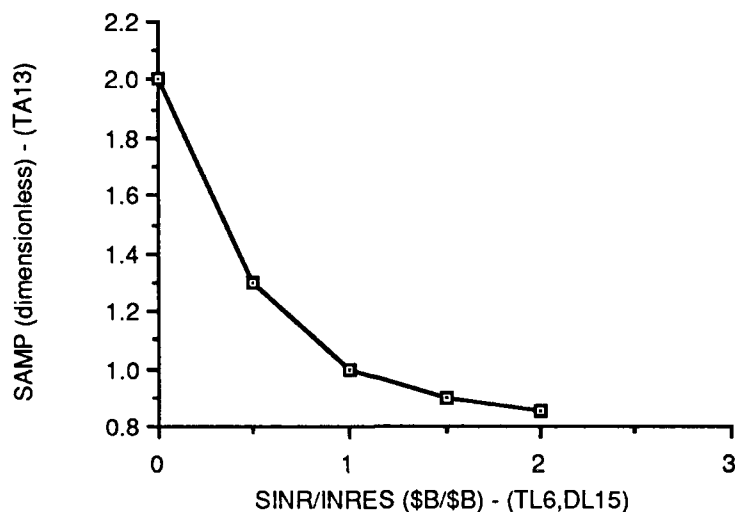
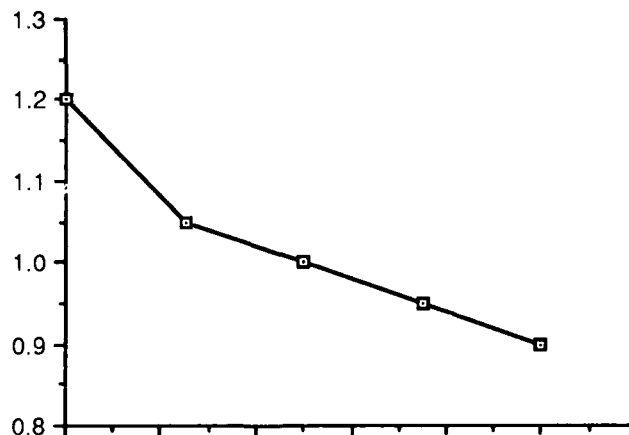

Figure 37. Structure of Soviet Intelligence Accuracy Amplitude

The Soviet perceived military capability difference (SPMCD) is an important factor in determining overall Soviet defense expenditures and also plays a key role in the determination of the global tension level. Basically it is the sum of the perceived differences between the Soviet and American military capability components. As the perceived military capability difference approaches zero or becomes negative the Soviets counter the perceived imbalance by increasing defense expenditures. A possible side affect of this situation is that global tensions would increase as feelings of military vulnerability increased. Perceived military capability differences for both the

United States and the Soviet Union are based upon military capability component differentials, intelligence accuracy, and the global tension level. Any capability differential is viewed relative to the current global situation. That is, a given capability comparison would be viewed differently in a high tension environment than it would in a low tension environment. The relationship between global tension and perceived military capability multipliers (SGTE and GTE) for both the Soviets and the United States are shown in Figures 38 and 39 respectively. The table functions indicate that at high levels of global tension that perceived differences are discounted, while at low levels of global tension perceptions are inflated.

A	$SPMCD.K = (SRE.K + SWIE.K + SWTE.K + SIE.K) * SGTE.K$	TA14
Note	Soviet Perception of Military Capability Difference (\$ billion).	
A	$SGTE.K = TABHL(TSCD, GT.K, 0, 100, 25)$	TA15
T	$TSCD = 1.2, 1.05, 1, .95, .9$	TT10
Note	Global Tension Effect on SPMCD (dimensionless).	
A	$PMCD.K = (RE.K + WIE.K + WTE.K + IRE.K) * GTE.K$	TA25
Note	US Perceived Military Capability Differential (\$ billion).	
A	$GTE.K = TABHL(TCD, GT.K, 0, 100, 25)$	TA26
T	$TCD = 1.2, 1.05, 1, .95, .9$	TT16
Note	Global Tension Effect on PMCD (dimensionless).	



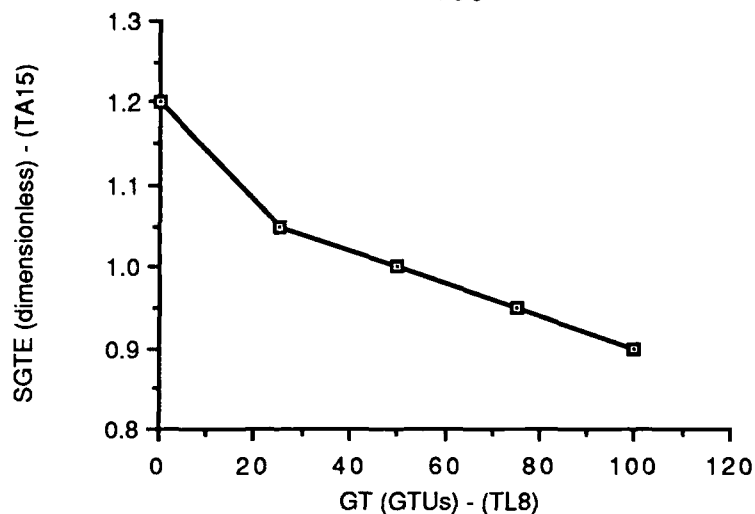

Figure 38. Structure for Global Tension Effect on Soviet Capability Perceptions

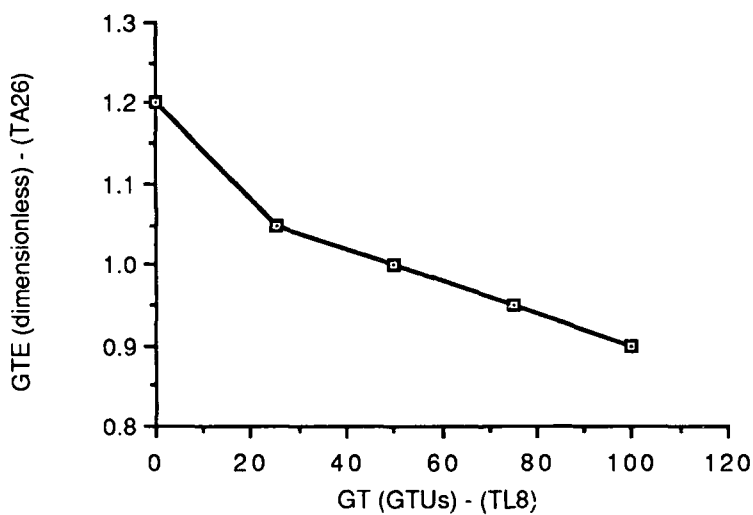

Figure 39. Structure for Global Tension Effect on US Capability Perceptions

The Soviet readiness effect on Soviet perceived military capability differential (SPMCD) is a function of the difference between the known level of Soviet readiness and the perceived level of United States readiness. A parallel structure is presented for the United States.

A	$SRE.K = SRED.K - (RED.K * SIAC.K)$	TA16
Note	Soviet Readiness Effect (\$ billion/Global Tension Unit).	
A	$SWIE.K = SWTK.K - (WPNTK.K * SIAC.K)$	TA17
Note	Soviet Weapon Inventory Effect (\$ billion/ Global Tension Unit).	
A	$SWTE.K = SWTK.K - (WPNTK.K * SIAC.K)$	TA18
Note	Soviet Weapon Technology Effect (\$ billion/Global Tension Unit).	
A	$SIE.K = SINR.K - (INRES.K * SIAC.K)$	TA19
Note	Soviet Intelligence Effect (\$ billion/Global Tension Unit).	
A	$RE.K = RED.K - (SRED.K * USIAC.K)$	TA27
Note	US Readiness Effect on Perceived Military Capability Differential.	
A	$WIE.K = WPNIN.K - (SWPN.K * USIAC.K)$	TA28
Note	US Weapon Inventory Effect on Perceived Military Capability Differential.	
A	$WTE.K = WPNTK.K - (SWTK.K * USIAC.K)$	TA29
Note	US Weapon Technology Effect on Perceived Military Capability Differential.	
A	$IRE.K = INRES.K - (SINR.K * USIAC.K)$	TA30
Note	US Intelligence Effect on Perceived Military Capability Differential.	

The desired tension level variables (SDT and USDT) represent political policies which act to modulate the global tension level and can be modified in different policy settings. The desired level of tension depends on the perceived military capability differential. As the military capability differential becomes more positive the country is less likely to avoid confrontation than if it faces an adverse situation in terms of relative military capability. These relationships for the Soviets and the United States are shown in Figures 40 and 41 respectively. The relatively slow rates of change which are possible reflect the rate at which the political bodies involved are able to change policy direction substantively in a short time.

L SDT.K=SDT.J+(DT*SDTRC.JK) TL7
 N SDT=50
 Note Soviet Desired Tension Level (Global Tension Units - GTUs).
 R SDTRC.KL=TABHL(TSDT,SPMCD.K,-200,200,100)*SDT.K TR7
 T TSDT=-.02,-.005,0,.005,.02 TT11
 Note Soviet Desired Threat Rate of Change (GTUs/year).
 L USDT.K=USDT.J+(DT*USDTRC.JK) TL9
 N USDT=50
 Note US Desired Tension Level (GTUs).
 R USDTRC=TABHL(TUSDT,PMCD.K,-200,200,100)*USDT.K TR9
 T TUSDT=-.02,-.005,0,.005,.02 TT15
 Note US Desired Threat Rate of Change (GTUs/year).

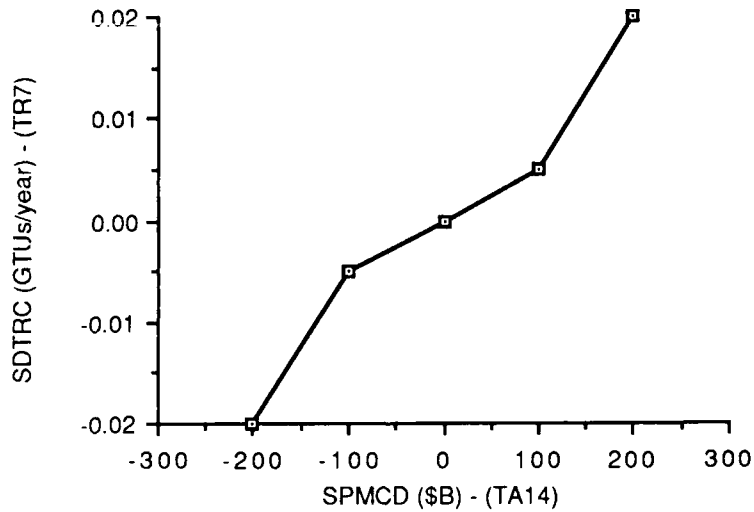

Figure 40. Structure for Soviet Desired Tension Rate of Change

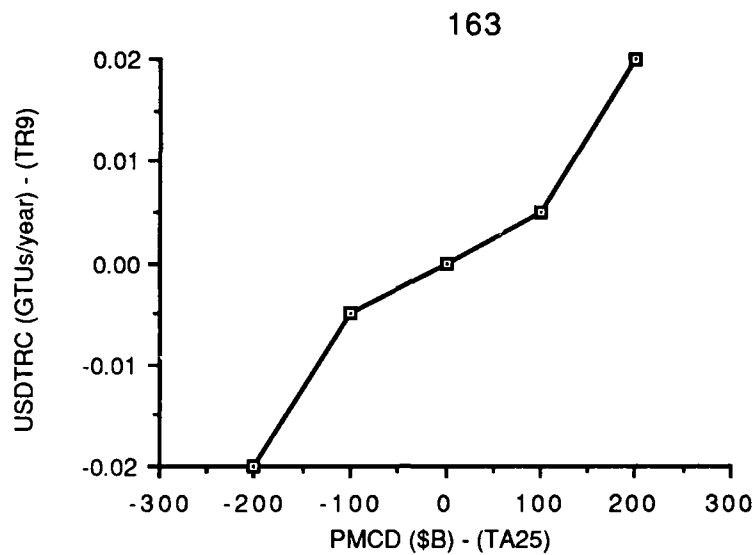

Figure 41. Structure for US Desired Tension Rate of Change

The global tension level changes because of differences between global tension and the desired levels of global tension, perceived differences in military capabilities and an intelligence impact. If either superpower desires a higher level of global tension than currently exists then it will pursue political and military policies which will increase the level of global tension. Likewise if either superpower desires a lower tension level then it would pursue policies which would act to lower the tension level. Any imbalance in military capabilities has the potential to increase global tension as well, this is why a "balance of power" is sought. Low levels of intelligence accuracy, on either side, can lead to uncertainty and misinterpretation which directly increase global tension. In order to replicate system behavior during the period 1960-1985 which was used as the reference mode an increase in global tension was added which corresponds to the Viet Nam war.

L $GT.K = GT.J + (DT * GTRC.JK)$ TL8
 N $GT = 50$
 Note Global Tension (GTUs).
 R $GTRC.KL = (GT.K * INE.K * (SPCE.K + USPCE.K + SDTE.K + USDTE.K)) + VNE.K$ TR8
 Note Global Tension Rate of Change (GTUs/year).

The effect of Soviet and United States perceived capability differentials on global tension are shown in Figures 42 and 43 respectively. The table functions reflect that if either country perceives a military imbalance that global tensions rise, conversely if either country perceives a favorable balance that tensions are reduced. In reality perceived military capabilities are not very accurate, and so situations where both countries perceive a positive or negative imbalance can occur.

A $SPCE.K = TABHL(TSPC, SPMCD.K, -200, 200, 100)$ TA20
 T $TSPC = .1, .02, 0, -.02, -.1$ TT12
 Note Soviet Perceived Military Capability Differential Effect on Global Tension
 Note (% change/year).

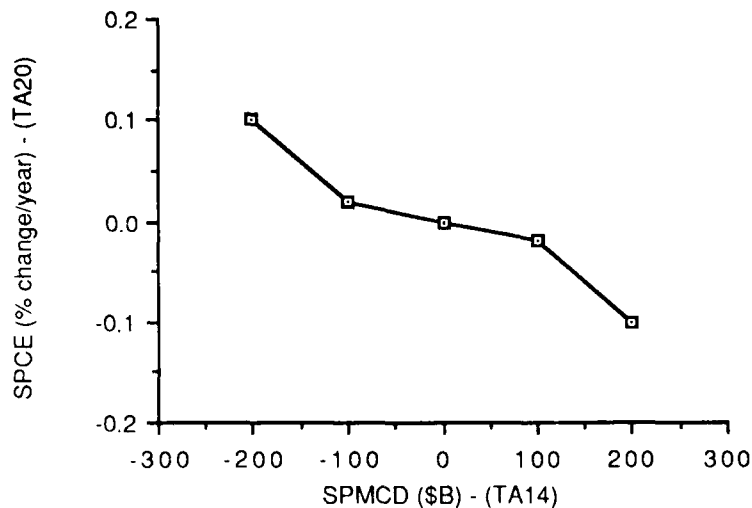

Figure 42. Structure for Soviets' Perceived Capability Differential Effect on Global Tension

A USPCE=TABHL(TUSPC, PMCD.K,-200,200,100)

TA21

T TUSPC=.1,.02,0,-.02,-.1

TT13

Note US Perceived Military Capability Differential Effect on Global Tension

Note (% change/year).

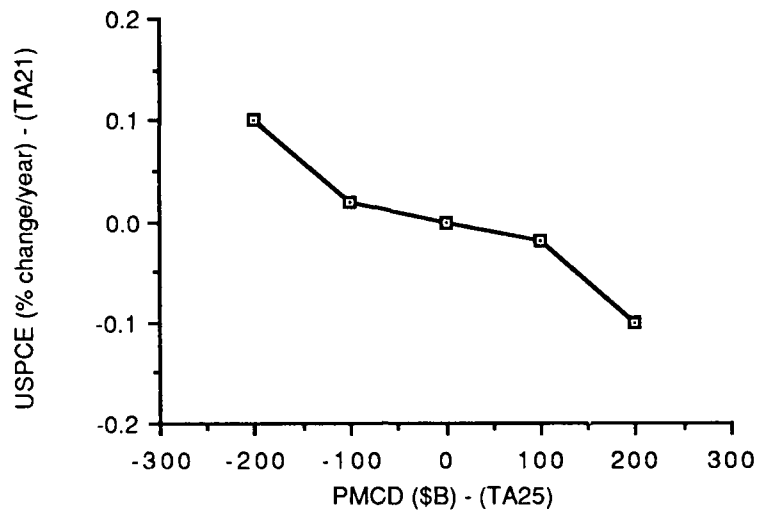

Figure 43. Structure for US Perceived Capability Differential Effect on Global Tension

The Soviet desired threat effect on global tension (SDTE) and the United States effect (USDTE) are determined based on the difference between the desired tension levels and the actual tension levels. A time delay of three and two years was used to reflect the ability of the two nations' political bodies to develop and enact policies which could reduce global tensions in a timely manner. These time delays reflect the length of time which the political systems require to generate consensus, the United States' reaction is assumed to be quicker because of the impact that public opinion has on the American political process, while the Soviet system is assumed to be slower to change because of

its bureaucratic structure.

A	$SDTE.K = (SDT.K - GT.K) / (3 * GT.K)$	TA22
Note	Soviet Political Behavior Effect on Global Tension (% change/year).	
A	$USDTE.K = (USDT.K - GT.K) / (2 * GT.K)$	TA23
Note	US Desired Threat Effect on Global Tension (% change/year).	

Soviet and United States intelligence accuracy fluctuate between 1.0 and 1.2, with one being perfect accuracy and 1.2 representing a 20% over estimation. A maximum of 20% over estimation may seem relatively small when considered as it relates to estimating individual capabilities, however in the aggregate it is felt that a 20% error would be quite large. The product of the two countries accuracy measures reflects the overall level of intelligence accuracy which impacts global tension. This reflects the fact that when both countries have relatively poor intelligence resolution the probability of misinterpreted intentions leading to global tension is at its highest. The relationship between intelligence accuracies and global tension is shown in Figure 44.

A	$INE.K = TABLE(TINE, USIAC.K * SIAC.K, 1, 1.5, .1)$	TA24
T	$TINE = 1, 1.02, 1.1, 1.15, 1.18, 1.2$	TT14
Note	Intelligence Effect on Global Tension (dimensionless).	

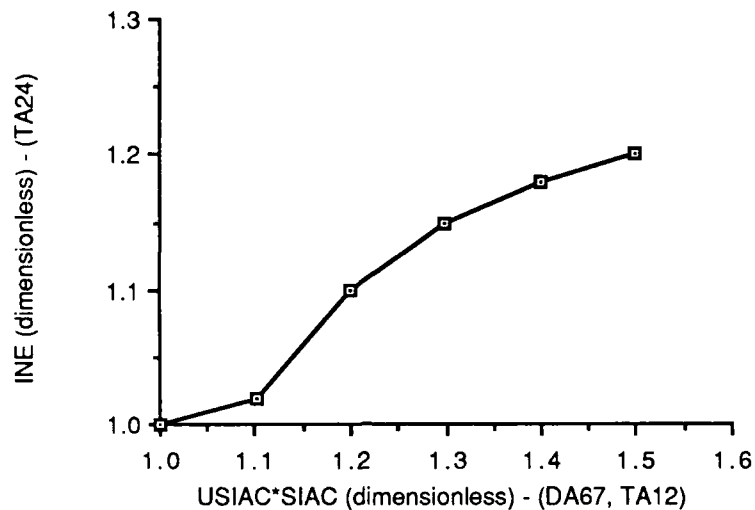

Figure 44. Structure of Combined Intelligence Accuracy Effect on Global Tension

The Viet Nam effect (VNE) on global tension was implemented in order to generate the increased levels of defense spending by the United States during the period 1965-1972 and also to increase the rate of weapon inventory depletion. This was accomplished by adding a dynamo ramp function which increased the level of global tension for three years beginning in 1965, and then decreased global tension beginning in 1969.

A $VNE.K=20*(RAMP(.4,5)-RAMP(.4,8)-RAMP(.4,9)+RAMP(.4,12))$

TA31

Note Viet Nam Effect on Global Tension Rate of Change (GTUs/year).

The threat sector model has detailed the interactions between United States and Soviet military capabilities as well shown the determinants of the global tension variable. This sector in conjunction with the defense sector provides the pressures to increase defense spending levels which are

determined in the national sector. The national sector will be described in detail in the next section.

National Sector

The national sector model includes the variables and concepts which make up the United States' macroeconomic system. The purpose of this sector model was to provide the structure which limits the growth of United States defense expenditures but not to fully model the United States economy. Only those output and input components important to this study were included. The structure of the national sector model is presented in the modified flow diagram presented in Figure 45. This model incorporates Low's (1980) system dynamics model of Samuelson's basic multiplier-accelerator model. As a result, detailed references for each concept have not been included as they are fully documented in Low's work. The multiplier-accelerator model was modified to include a more detailed government spending structure, and the effect of interest rates and federal revenues. Initial values for this model were taken from the "Historical Tables, Budget of the U.S. Government, 1987" and Low's (1980) model.

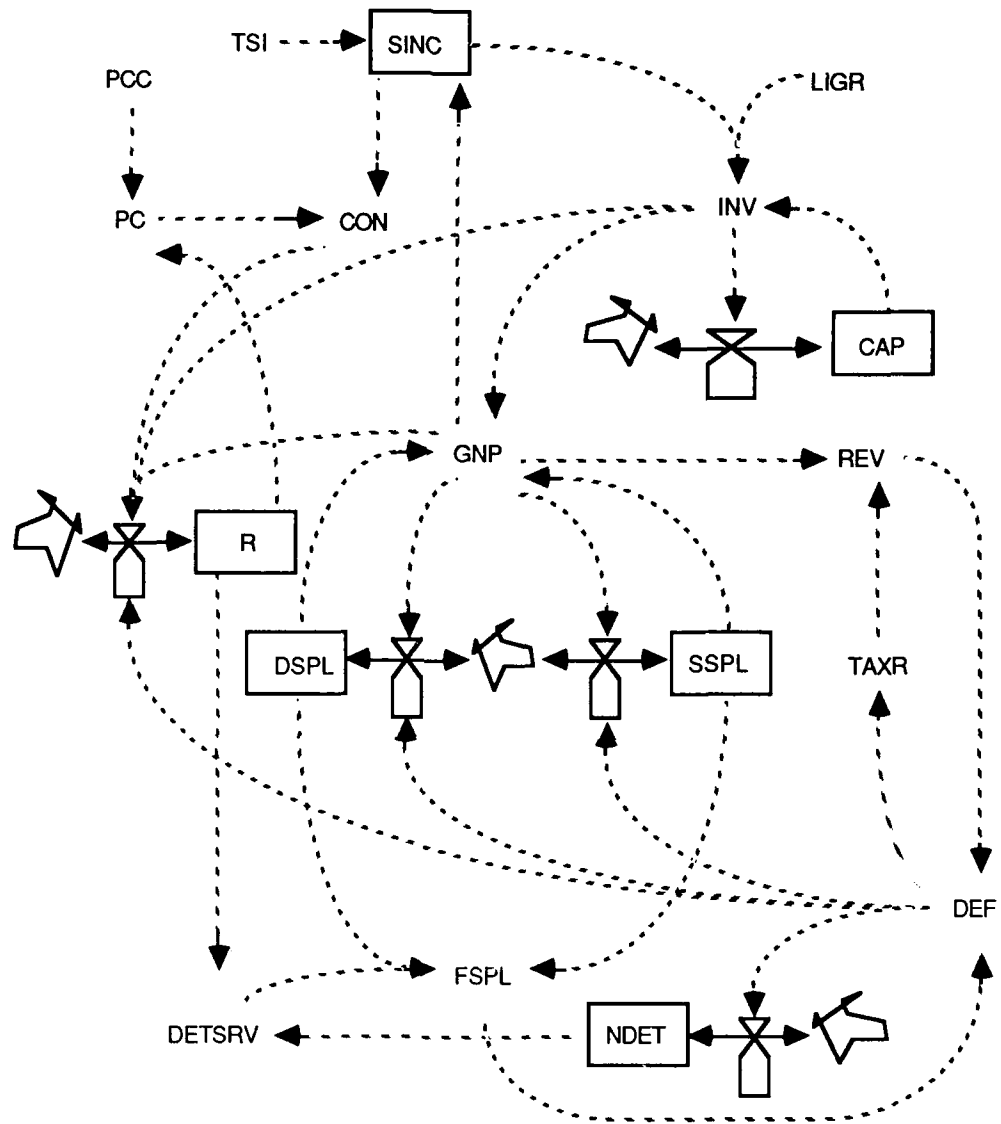

Figure 45. National Sector Modified Flow Diagram

Table 2. -- Figure 45 Key

VARIABLE	NAME	MEASURE
CAP	Capital Stock	\$ billion
CON	National Consumption	\$ billion/year
DEF	Federal Deficit	\$ billion
DETSRV	Debt Service	\$ billion/year
DSPL	Defense Spending Level	\$ billion/year
FSPL	Federal Spending Level	\$ billion/year
GNP	Gross National Product	\$ billion/year
INV	Net Investment	\$ billion/year
LIGR	Long-run Investment Growth Rate	% change/year
NDET	National Debt	\$ billion
PC	Propensity to Consume	%
R	Aggregate Rate of Interest	APR
REV	Federal Revenues	\$ billion/year
SINC	Smoothed Income Level	\$ billion/year
SSPL	Social Spending Level	\$ billion/year
TAXR	Aggregate Tax Rate	%
TSI	Time to Smooth Income	years

National income or gross national product (GNP) is composed of national consumption, net investment, and government spending excluding debt service. Consumption is determined by lagged income and the propensity to consume which is a function of interest rates. The relationship between interest rates and the propensity to consume, shown in Figure 46, reflects a decrease in the propensity to consume with rising interest rates as the incentive to save increases.

A	$GNP.K=CON.K+INV.K+(SSPL.K+DSPL.K)$	NA1
Note	Gross National Product, National Income (\$ billion/year).	
A	$CON.K=PC.K*SINC.K$	NA2
Note	Consumption (\$ billion/year).	
A	$PC.K=PCC*REPC.K$	NA3
Note	Propensity to Consume (\$ consumption/\$ income).	
C	$PCC=.8$	
Note	Initial Propensity to Consume.	
A	$REPC.K=TABHL(TREPC,R.K,0,.1,.02)$	NA4
T	$TREPC=1.01,1.003,1,.999,.996,.99$	NT1
Note	Interest Rate effect on propensity to consume (dimensionless).	

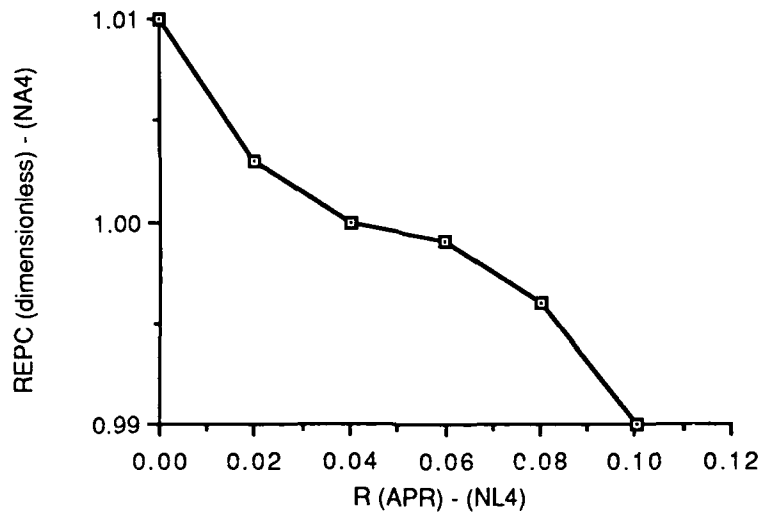

Figure 46. Structure for Interest Rate Effect on Propensity to Consume

Consumption is based on smoothed income as consumers tend to save more of each additional dollar of income when incomes are rising and likewise tend to reduce spending more slowly when incomes decline. The "time to smooth income" variable reflects the length of time delay for consumers to fully increase or decrease their consumption based on a change in real income. A two-year time to smooth income value implies that consumption will change only half as much as income in a given year. Consumption changes, in other

words, lag income (Gapinski 1982, Low 1980). An initial smoothed income of \$482 billion was chosen, because it results in an initial level of GNP which corresponds closely to the initial level in 1960.

L	$SINC.K=SINC.J+(DT*SINCRC.JK)$	NL1
N	$SINC=482$	
Note	Smoothed Income (\$ billion/year).	
R	$SINCRC.KL=(GNP.K-SINC.K)/TSI$	NR1
Note	Smoothed Income Rate of Change (\$ billion/year/year)	
C	$TSI=2$	
Note	Time to Smooth Income (years).	

Net investment (INV) in the Low (1980) model is based on the difference between the current capital stock and the desired capital stock and the time it takes to adjust the capital stock (NTACAP). Net investment includes the investment in capital equipment, depreciation of that equipment, and investment in inventories. If depreciation exceeds capital investment or inventories are allowed to decline, it is possible to have negative net investment. The structure of the Low (1980) model did reproduce the very long-term behavior of the United States economy so the investment in any given year in this study was modeled to provide the observed dynamics of the system, with a long term growth of 4% per year. A sine function was used because of the tendency of the United States economy to experience a cyclical growth pattern. The parameters which have been used were chosen specifically because they result in long-run growth similar to that of the actual system. The process of selecting parameters for the model is discussed in detail in Chapter 6.

The capital stock level, which includes capital equipment and inventories,

changes based on net investment in inventories, and net investment in capital equipment.

A	$INV.K=LIGR*SINC.K*(2+SIN(6.283*TIME.K/IPER))$	NA5
Note	Net Investment (\$ billion/year).	
C	$IPER=15$	
Note	Long-run Investment cycle Period (years).	
C	$LIGR=.04$	
Note	Long-run Investment Growth Rate (% change/year).	
L	$CAP.K=CAP.J+DT*INV.J$	NL2
N	$CAP=1100$	
Note	Capital Stock (\$ billion).	

Government spending or Federal spending level (FSPL) is composed of three components: social spending (SSPL), defense spending (DSPL), and debt service (DETSRV). Social spending is an overall category which includes all Federal spending except for debt service and defense spending. Each of the component levels reflects the level of annual expenditures rather than budget levels which in reality reflect only obligation authority. Social spending increases at up to 12% annually in real terms depending on lagged information concerning the deficit. As the deficit increases, the rate of increased spending falls to a low of 5.5% for any deficit which exceeds five percent of GNP, this relationship is shown in Figure 47. These values are consistent with the behavior of the system since 1960.

A $FSPL.K = SSPL.K + DS.L.K + DETSRV.K$ NA6
 Note Federal Spending Level (\$ billion/year).
 L $SSPL.K = SSPL.J + (DT * SSPLRC.JK)$ NL3
 N $SSPL = 37$
 Note Social Spending Level (\$ billion/year).
 R $SSPLRC.KL = SSPL.K * DESS.K / 2$ NR3
 Note Social Spending Level Rate of Change (\$ billion/year/year)
 A $DESS.K = TABLE(TSS, SDEF.K / GNP.K, -.05, .05, .025)$ NA7
 T $TSS = .12, .09, .07, .06, .055$ NT2
 Note Deficit Effect on Social Spending (% change/year).

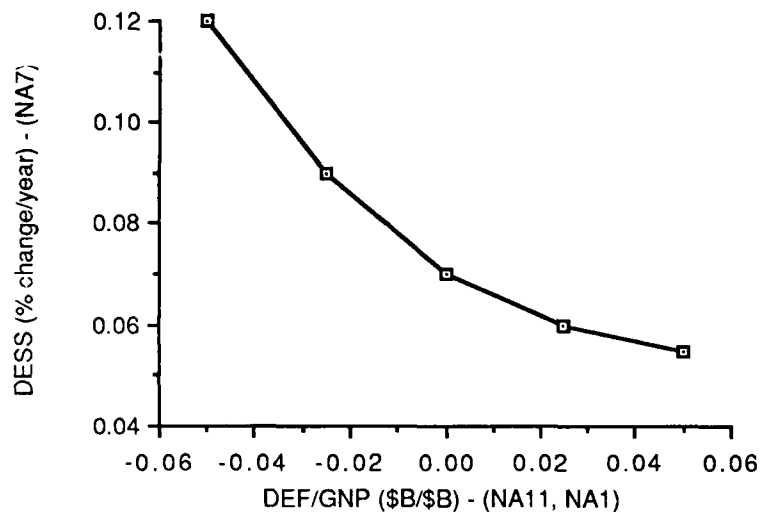

Figure 47. Structure for Deficit Effect on Social Spending

Annual debt service is calculated by multiplying the current accumulated national debt by the rate of interest. Interest rate is modeled as a level corresponding to real interest rates that changes based on the relationship between money demanded for investment and debt service and the money supplied by savings, which is the difference between income and consumption. Real interest rates do not include the impact of inflation on the time value of money. The model does not include the impact of foreign investment which was

judged to be an unnecessary structure because of its dependence on random world events which cannot be modeled systemically. The relationship between interest rates, money supply and money demand reflects a maximum rate of increase of ten percent of current rates in any given year, and a maximum decline of six percent of current rates in a given year which approximates the behavior of real interest rates since 1960. This relationship is shown in Figure 48.

A	$DETSRV.K = NDET.K * R.K$	NA9
Note	Debt Service (\$ billion/year)	
L	$R.K = R.J + (DT * RRC.JK)$	NL4
N	$R = .05$	
Note	Interest Rate (APR).	
R	$RRC.JK = R.K * TABHL(TR, BOR.K / SAV.K, 0, 1, .2)$	NR4
T	$TR = -.06, -.03, -.01, 0, .02, .1$	NT3
Note	Interest Rate rRate of Change (APR/year).	
A	$SAV.K = GNP.K - CON.K$	NA9
Note	Annual Savings (\$ billion/year).	
A	$BOR.K = INV.K + DEF.K$	NA10
Note	Annual Borrowing (\$ billion/year)	

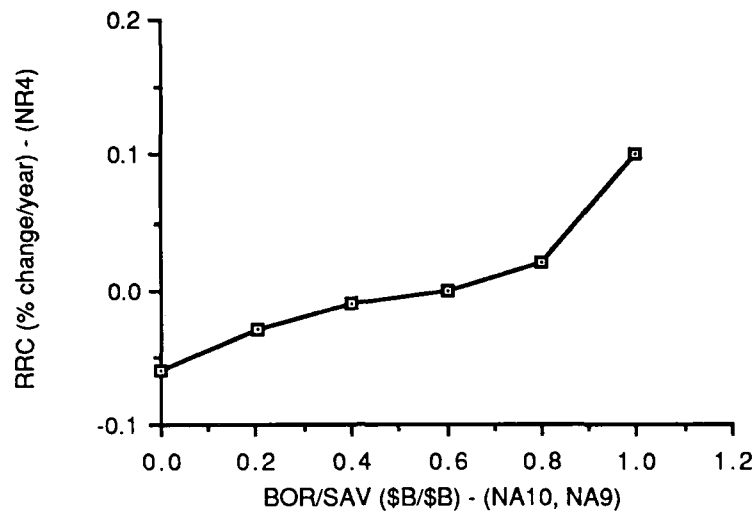

Figure 48. Structure for Interest Rates Rate of Change

The national debt is a level which accumulates the annual deficits or surpluses of the federal government. The annual deficit is simply the difference between total Federal spending and Federal revenues. A surplus is simply a negative deficit. Debt is retired in years when a surplus occurs. Federal revenues are determined by multiplying the GNP by an aggregate tax rate. The tax rate is increased or decreased depending on whether a deficit or surplus is experienced. The impact of the deficit on the tax rate is adjusted by the impact of the time lag between determining the extent of the deficit and the passage of tax legislation. An additional factor is the time lag in gathering information concerning the level of the annual deficit which results in decisions being made without current information. The delays due to these factors have been accommodated using an exponential smoothing function (DLINF3). The initial tax rate of 18% was calculated by dividing 1960 revenues by 1960 GNP. The

relationship between tax rates and the deficit is shown in Figure 49. The rate of change is assymetrical which reflects the relative ease with which taxes can be reduced and the relative difficulty which is encountered when trying to raise tax rates significantly.

L	$NDET.K = NDET.J + (DT * DEF.K)$	NL5
N	$NDET = 138$	
Note	National Debt (\$ billion).	
A	$DEF.K = FSPL.K - REV.K$	NA11
Note	Federal Spending Deficit (\$ billion/year).	
A	$SDEF.K = DLINF3(DEF.K, 2)$	
Note	Smoothed Deficit (\$ billion).	
A	$REV.K = TAXR.K * GNP.K$	NA13
Note	Revenues (\$/year).	
L	$TAXR.K = TAXR.J + (DT * TRRC.JK)$	NL6
N	$TAXR = .18$	
Note	Tax Rate (% of aggregate income).	
R	$TRRC.KL = TAXR.K * DETR.K$	NR6
Note	Tax Rate Rate of Change (%/year).	
A	$DETR.K = DLINF3(TABLE(TDT, SDEF.K / GNP.K, -.05, .05, .025), 3)$	NA14
T	$TDT = -.2, -.1, 0, .005, .02$	NT4
Note	Deficit Effect on Tax Rates (% change/year).	

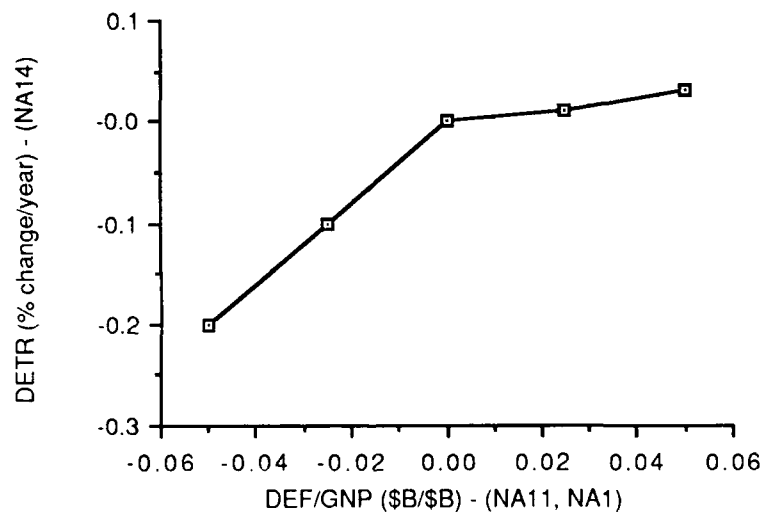

Figure 49. Structure for Tax Rate Rate of Change

Annual defense spending levels (DSPL) change in reaction to two factors: the effect of the deficit and the perception of the threat. The three year lag in the smoothed deficit effect reflects the length of time that it takes for information concerning the deficit to impact spending. The impact of the threat is divided between the effect of the perceived military balance with the Soviets, a separate effect from changing global tension and a one time effect which is referred to as the "early eighties arms build-up". The relationship between the deficit and the defense spending rate of change is shown in Figure 50. The table function reflects the tendency to rapidly decrease the defense budget in the face of extended deficit pressures when threat related spending pressures are not considered. The table functions which determine the effects of the pressures to alter defense spending were derived in conjunction with one another. The combination of values was picked which best replicated the pattern of spending from 1960-1985. This process, which is part of the validation process, is described in more detail in Chapter 6. Because each of the forces acts on defense spending simultaneously it is not possible to accurately estimate them independently.

	L DSPL.K=DSPL.J+(DT*DSLRC.JK)	NL7
	N DSPL=41	
Note	Defense Spending Level (\$ billion/year).	
	R DSLRC.KL=DSPL.K*(DEDS.K+GTEDS.K+PCDEDS.K+EEAB.K)	NR7
Note	Defense Spending Level Rate of Change (\$ billion/year/year).	
	A DEDS.K=DLINF3(TABHL(TDD,SDEF.K/GNP.K,-.05,.05,.025),3)	NA15
	T TDD=.02,.002,0,-.025,-.07	NT5
Note	Deficit Effect on Defense Spending Level (% change/year).	

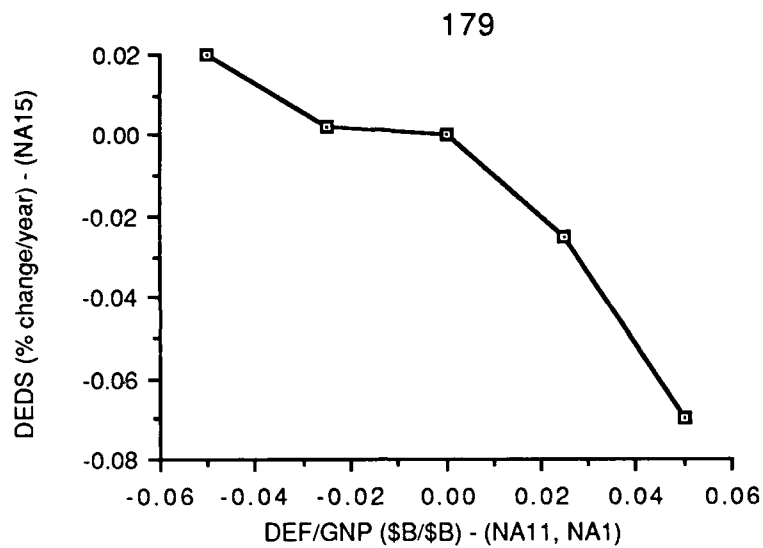

Figure 50. Structure for Deficit Impact on Defense Spending

The relationship between changing global tension levels and defense spending changes is shown in Figure 51. The table function reflects that as tension increases, spending increases at a faster rate than it would decrease in times of falling tensions.

A GTEDS.K=TABHL(TGTDS,GT.K-DLINF3(GT.K,1),-10,10,4)

NA16

T TGTDS=-.04--02,-.01,.01,.08,.1

NT6

Note Global Tension Effect on Defense Spending (% change/year).

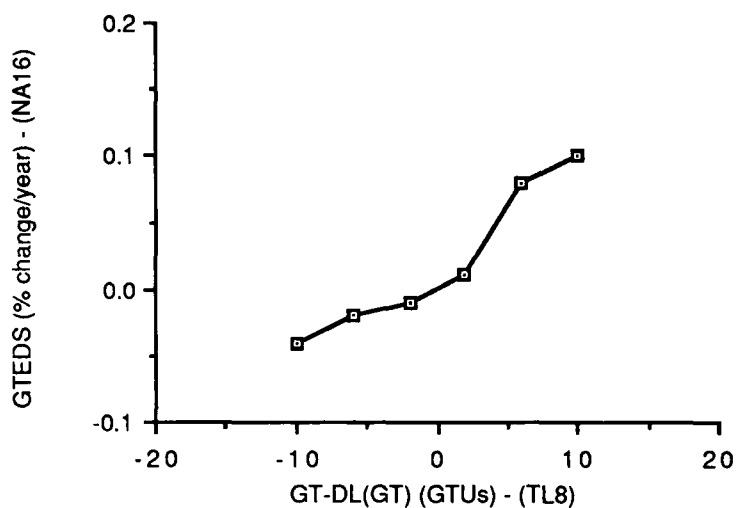

Figure 51. Structure for the Impact of Global Tension on Defense Spending

The second effect of the threat on defense spending is the relationship between perceived military capability differential and changes in defense spending. This relationship is shown in Figure 52. The table function reflects that when the perceived difference is greater than \$100 billion, there is no pressure to increase or decrease defense spending. However, when the the difference falls below this level the result is a rapidly increasing rate of change.

A PCDEDS.K=TABHL(TPCDDS,PMCD.K,-100,100,50)

T TPCDDS=.03,.028,.02,.005,0

NA17

NT7

Note Perceived Capability Differential Effect on Defense Spending (% change/year).

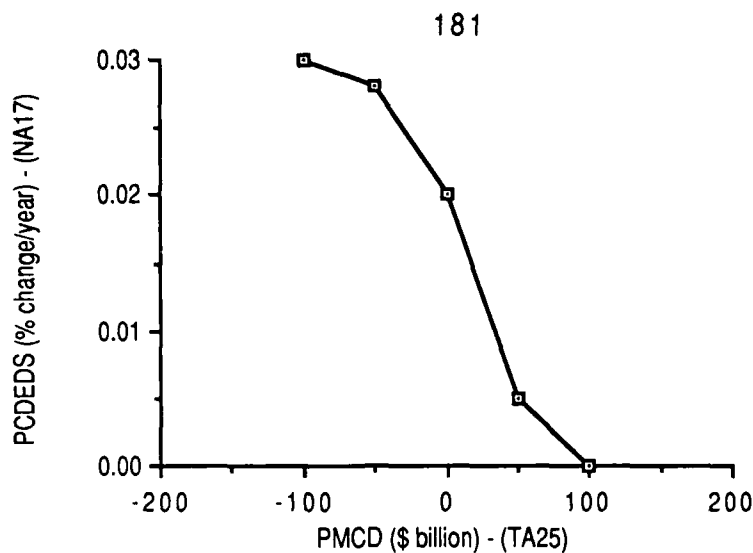

Figure 52. Structure for Impact of Perceived Military Capability Differential on Defense Spending

The "early eighties arms build-up" (EEAB) was included in the model because it represents a departure from the volatility of past changes in defense spending levels. The build-up took place in a period when global tensions were lower than during the Viet Nam build-up and in the face of growing deficits. One possible explanation for the build-up is the fact that the United States was passed in annual defense expenditures at some time during the mid 1970's by the Soviets, (Collins 1978) and this realization led to a political situation where it was possible to rapidly increase peace time defense expenditures. This is not considered to be a permanent structure and has thus been modeled as a separate, one-time phenomena, although it is realized that under the right circumstances it could happen again. The build-up is modeled as a annual step increase in defense expenditures beginning in 1979 and ending in 1983 at which time the model structure takes over.

EEAB.K=DLINF3((STEP(.07,17)+STEP(.13,18)-STEP(.2,21)),2)
Note Early Eighties Arms Buildup (% change/year).

NA18

The national sector model provides the structure which determines the level of defense spending based on competing pressures. These pressures include global tension, perceived military capability differential and deficit reduction pressures. The defense sector model, which is described in the next section, provides the structure which allocates the defense funds to the four defense categories based on competing pressures as well.

Defense Sector

The defense sector model includes the variables which interact and make up the defense budgeting process, the requirements determination process, the weapon specification process, and the weapon development process. The conceptual model, which provided the basis for the parametric structure which is presented in this chapter, was presented in Chapter 4. The defense sector model determines the amount of the defense expenditures which are allocated to each of four spending components: intelligence resolution; operations, maintenance and personnel; research and development; and weapon acquisition. Spending in each of these categories leads to increased military capability which is portrayed in four dimensions: intelligence resolution, readiness, weapon technology and weapon inventory. The budget figures which have been used to parameterize this model were derived from the United

States Air Force Summary 1986 (Comptroller of the Air Force 1986).

The structure of the defense sector was broken down in order to simplify its presentation. The sector was divided into four subsectors which correspond to the structure associated with a single component of military capability. The military capability components are: weapon inventory, weapon technology, readiness and intelligence resolution. The first subsector which is described is the weapon inventory sector, which includes the process of weapon development and weapon production.

Weapon Inventory Structure

This subsector model details the flow of weapon systems through the weapon system "pipeline" beginning with their development and ending with production. This subsector includes the decision making process concerning how many systems are developed, how many are cancelled, how many are produced, as well as how many units of each system are produced, how many units are produced each year and how long systems remain in production. The structure of the weapon inventory subsector model is shown in Figure 53.

Each of the four military capability dimensions were modeled as a level, measured in dollars, which increases with annual expenditures and decreases with use and attrition. The structure is similar to that for Soviet capability dimensions in the threat sector. While some might argue against measuring military capability in terms of dollars of inventory or dollars of intelligence

Table 3. -- Figure 53 Key

VARIABLE	NAME	MEASURE
DCST	Development Cost	\$ billion/system
DCR	Development Completion Rate	systems/year
DCNX	Development Cancellation Rate	% of systems/year
DPST	Desired Production Starts	systems/year
DST	Development Starts	systems/year
ICAP	Industry Capital Stock	\$ billion production/year
OBS	Obsolescence Rate	systems/year
PCNX	Production Cancellations	systems/year
PCOM	Production Completions	systems/year
PFND	Production Funds	\$ billion/year
PROR	Production Rate	units/system/year
PST	Production Starts	systems/year
SAFP	Systems Available for Production	systems/year
SDP	System Development Period	years
SID	Systems in Development	systems
SIP	Systems in Production	systems
SPP	System Production Period	years
TKAV	Technology Available	\$ billion
TKPRO	Technology Produced	\$ billion
UCST	Unit Cost	\$ billion/unit/system
UPS	Units Produced per System	units/system
WASL	Weapon Acquisition Spending Level	\$ billion/year
WIRC	Weapon Inventory Rate of	\$ billion/year
WPNIN	Weapon Inventory Level	\$ billion

resolution, it was essential that the capability components be additive and thus in commensurable units. This operationalization limits the applicability of the model to particular uses, but at the same time, it is acceptable for the policy analyses that the model was developed to support.

The weapon inventory level is increased with the production of each unit of each weapon system. The value of each unit is reflected by the unit cost of the weapon. Each dollar of weapon added to the inventory is weighted by a relative technology measure. The technology multiplier is a function of the ratio of the United States' technology level to that of the Soviets. This formulation allows for the weapon inventory level to reflect the long term impact of weapon technologies while the weapon technology level reflects only the current situation. If the current weapon technology ratio favors the United States, additions to the inventory in that year will be multiplied by the technology factor. The relationship between the technology ratio and the multiplier is shown in Figure 54. The initial level of the United States weapon inventory level was chosen based on initial annual expenditures on weapon procurement of seven billion dollars (Peck and Scherer 1962, 26) and a 25 year depreciation rate.

L	$WPIN.K = WPIN.J + (DT * WIRC.JK)$	DL1
N	$WPIN = 175$	
	Note US Weapon Inventory (\$ billion).	
R	$WIRC.KL = (PROR.K * SIP.K * UCST.K) * WPNTM.K - (WPIN.K / USWDR.K)$	DR1
	Note Weapon Inventory Rate of Change (\$ billion/year).	
A	$WPNTM.K = TABHL(TWTM, WPNTK.K / SWTK.K, 0, 2, .5)$	DA1
T	$TWTM = .8, .95, 1, 1.03, 1.05$	DT1
	Note Weapon Technology Multiplier (dimensionless).	

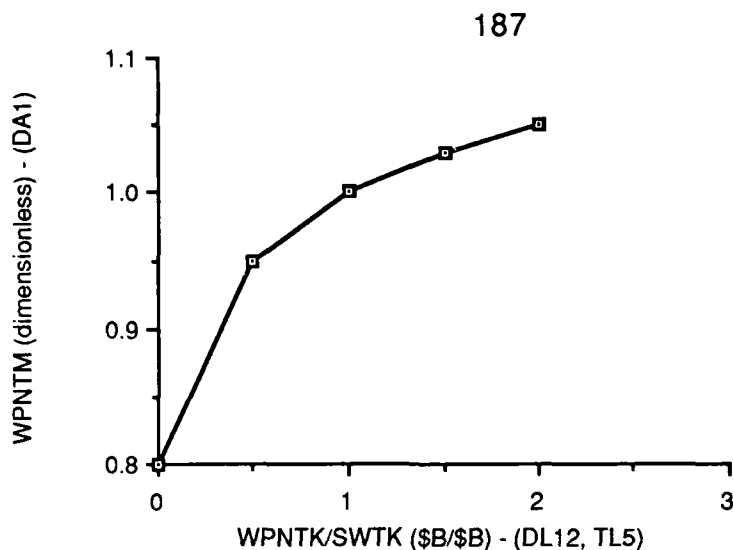

Figure 54. Structure for Weapon Technology Multiplier

The depletion rate of the weapon inventory is a function of the level of force maintainability, training and global tension. The relationship is shown in Figure 55. As the level of training or global tension increases the depreciation period in years of the weapon inventory decreases. This is somewhat offset by increased maintainability with higher levels of maintainability causing weapons to depreciate more slowly.

A USWDR.K=TABHL(TWDR,(TRAF.K+GT.K)*FMM.K,0,100,20)

T TWDR=50,30,25,20,10,.5

Note US Weapon Depletion Rate (years).

DA2

DT2

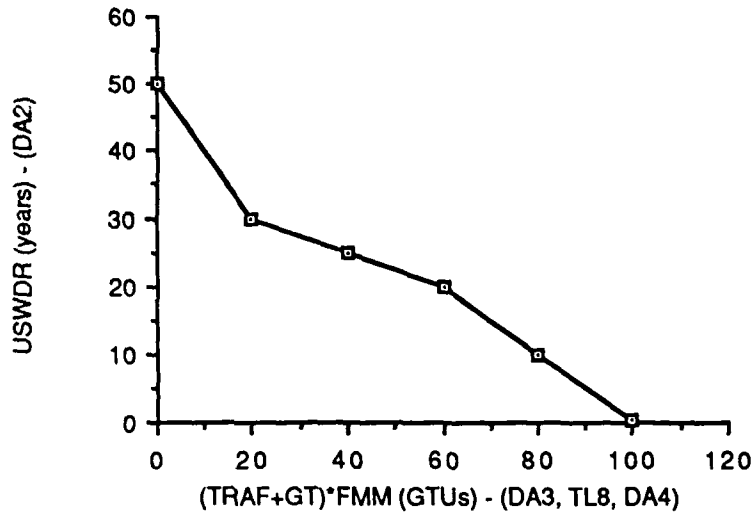

Figure 55. Structure for Weapon Depletion Rate

The impact of training on the depreciation of the weapon inventory is determined by the annual training budget relative to the total defense expenditures. The table function DT3, shown in Figure 56, relates a relative level of training to a global tension level so that the two effects become additive. A training budget below five percent of the defense expenditures is relatively low and so the impact of global tension on weapon depreciation is reduced.

A TRAF.K=TABHL(TTRAF,TRA.K/DSPL.K,0,.2,.05)

DA3

T TTRAF=-5,-1,0,.5,1,2,4

DT3

Note Training factor (dimensionless).

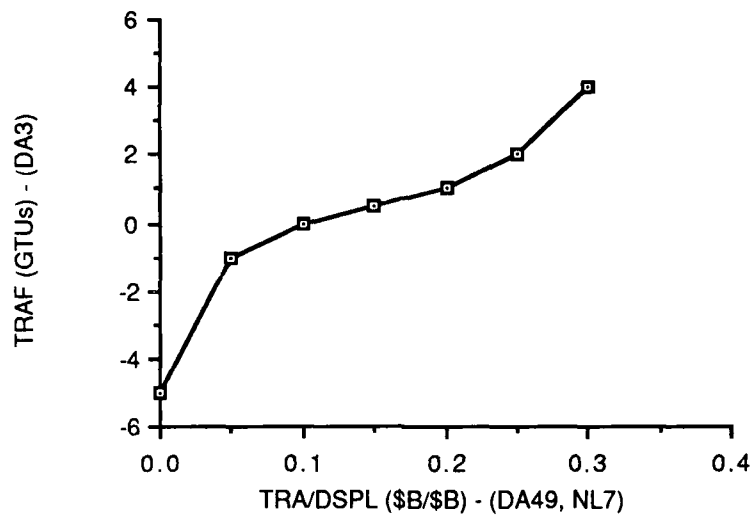

Figure 56. Structure for Training Effect on Weapon Depletion

The impact of force maintainability on weapon depletion was modeled as a multiplier. The global tension and training effects are added and then multiplied by a force maintainability multiplier (FMM). Low levels of force maintainability result in a multiplier of greater than one which causes more rapid depreciation. Relatively high levels of force maintainability result in slower depreciation. The relationship between the multiplier and force maintainability is shown in Figure 57.

A FMM.K=TABLE(TFMM,FM.K,0,1,.2)

T TFMM=2,1.8,1.2,1.05,.95,.9

Note Force Maintainability Multiplier (dimensionless).

DA4

DT4

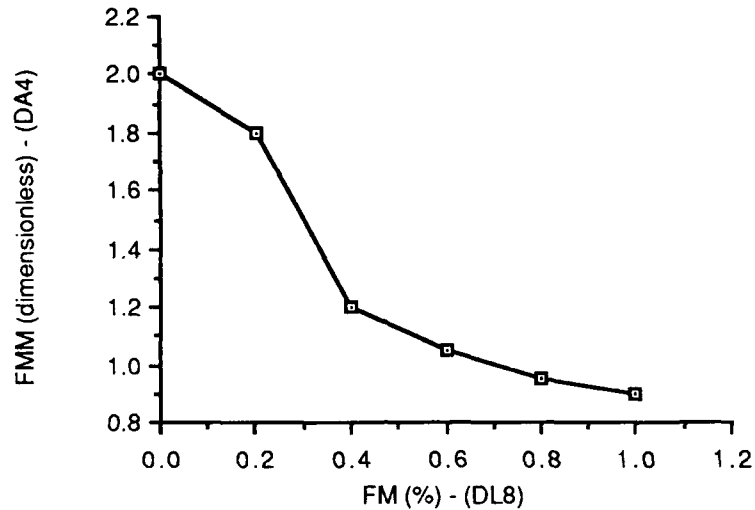

Figure 57. Structure for Force Maintainability Effect on Weapon Depreciation Rate

The amount of funds spent on weapon acquisition in a given year is determined by multiplying the weapon acquisition share (WASS) by the annual defense expenditures. The weapon acquisition share is a function of the ratio of the United States weapon inventory to the perceived Soviet weapon inventory. The relationship between weapon acquisition share and the weapon inventory ratio is shown in Figure 58. As in the threat sector the perceived Soviet levels are determined by multiplying actual levels by United States intelligence accuracy (USIAC). The range of values indicated in table function DT5 corresponds to the actual share of annual defense expenditures allocated to weapon procurement since 1960.

A $WASL.K = WASS.K * DSPL.K$

DA5

Note Weapon Acquisition Spending Level (\$ billion/year)

A $WASS.K = TABHL(TWASS, WPNIN.K / (USIAC.K * SWPN.K), 0, 2, .5)$

DA6

T $TWASS = .35, .33, .29, .26, .24$

DT5

Note Weapon Acquisition Spending Share (%) of annual defense spending.

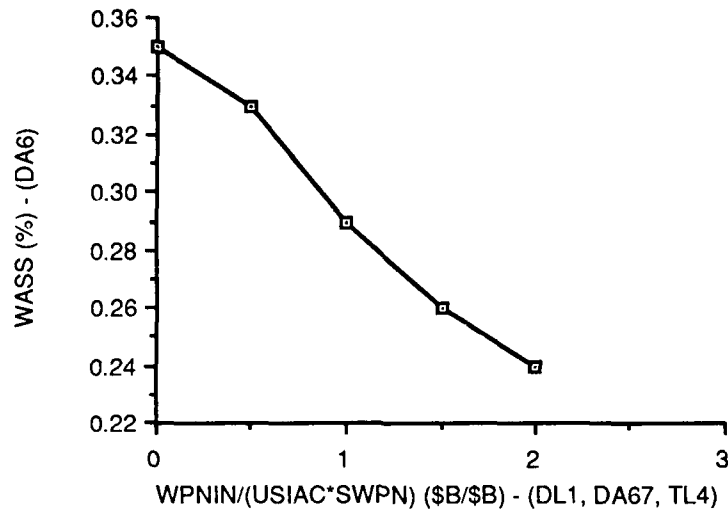

Figure 58. Structure for Weapon Acquisition Spending Share

The weapon acquisition process begins with the development of weapon systems. Individual types of weapon systems are aggregated into a level (systems in development - SID) which rises and falls as new systems are started, or as those in development are either made available for production or cancelled. The number of annual development starts is a function of weapon system affordability which was discussed in Chapter 4. Affordability is determined parametrically by the ratio between the cost of developing a weapon system and the amount of funds available for weapon acquisition. A constant eight percent of the annual spending level is made available for annual weapon development spending, this corresponds to the roughly constant levels of research and development funding since 1960. As the annual cost of weapon development increases relative to acquisition spending, the number of systems which are started is fewer and the system development

period is extended (Clark et al. 1985). The initial number of "systems in development" was chosen in conjunction with the initial values of "systems in production," "systems available for production," "system development period" and "system production period" so that the system was initially in a state of equilibrium and in agreement with the data presented in Peck and Scherer (1962). Approximately 90 major weapon systems were in development during the period 1945 to 1960 with approximately half of them never going into production (Peck and Scherer 1962, 645-667). This corresponds to approximately six development starts per year, with an average development time of four years (Smith and Friedmann 1980). This means that approximately 24 systems would be in development at any given time.

L	$SID.K = SID.J + DT * (DST.JK - DCR.JK - DCNX.JK)$	DL2
N	SID=24	
Note	Systems In Development (systems).	
	$SIDRC.KL = (DST.K - DCR.K - DCNX.K) * ((1 - SID.K) / SID.K)$	DR2
Note	Systems in Development Rate of Change (Systems/year)	
A	$DST.K = DSP * WASL.K / (DCST.K / SDP.K)$	DA7
Note	Development Starts (systems/year)	
C	DSP=.08	
Note	Development Starts Proportion of WASL (%)	

The rate at which systems in development are completed is determined by the system development period (SDP). The development period is affected by the weapon technology inherent in the specifications and the cost of developing a system. As the cost of developing a system increases, the period is increased so that the acquisition of other systems remains affordable. The relationship between weapon technology and its effect on development period is shown in

Figure 59.

A	$DCR.K = SID.K / SDP.K$	DA8
Note	Development Completion Rate (systems/year).	
A	$SDP.K = WTKE.K * DCSTE.K$	DA9
Note	System Development Period (years).	
A	$WTKE.K = TABHL(TWTKE, TKPRO.K, 0, 10, 2)$	DA10
T	$TWTKE = 3.5, 3.8, 4, 4.05, 4.2, 4.6$	DT6
Note	Weapon Technology Effect on system development period (years).	

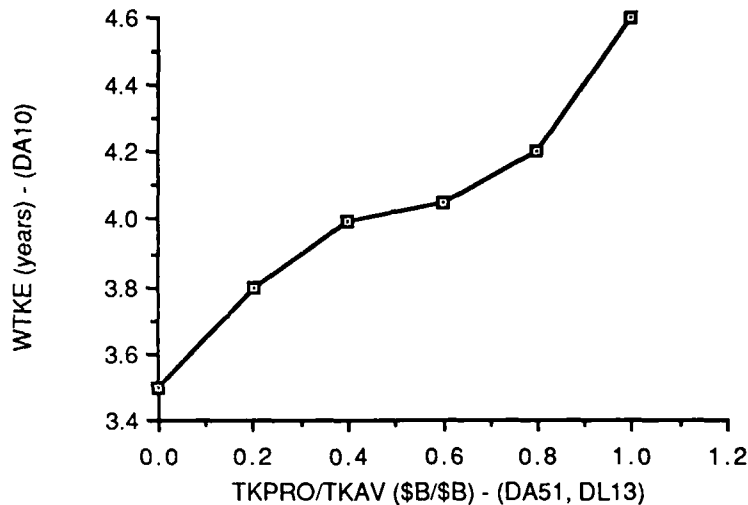

Figure 59. Structure for Weapon Technology Effect on Development Period

The relationship between development cost and development period is shown below as a linear relationship between the two variables. The "development cost effect" is a multiplier of the "weapon technology effect" described above. The "weapon technology effect" determines the "normal" system development period based on the technology level. This "normal" period is then multiplied by development cost effect which is determined by the ratio between the development cost and the weapon acquisition spending level. As the development cost gets cheaper relative to the funding available then the

development period can be shortened by applying additional funds more quickly. On the other hand if development cost gets large in relation to acquisition funding then it is more likely that the development period will be stretched out to allow more programs to be funded.

A $DCSTE.K = .5 + (12 * DCST.K / WASL.K)$ DA11
 Note Development Cost Effect on system development period (dimensionless).

The number of systems in development which are cancelled in any given year ranges between zero and 13.5% depending upon the number of systems that are available for production. Its actual value is set by policy managers, and so it becomes an important experimental factor. A cancellation rate of 10% reflects a 46% chance for any system to be cancelled during a four year development. Peck and Scherer reported that slightly more than 50% of the systems in development between 1945 and 1960 were cancelled (1962, 645-667) however some systems in the model are cancelled after completing development. The relationship between the number of systems available for production and the cancellation rate is shown in Figure 60.

A $DCNX.K = SID.K * DCNXR.K$ DA12
 Note Development Cancellations (systems/year)
 A $DCNXR.K = TABHL(TDCR, SAFF.K, 0, 10, 2)$ DA13
 T $TDCR = 0, .07, .1, .12, .13, .135$ DT7
 Note Development Cancellation Rate (%).

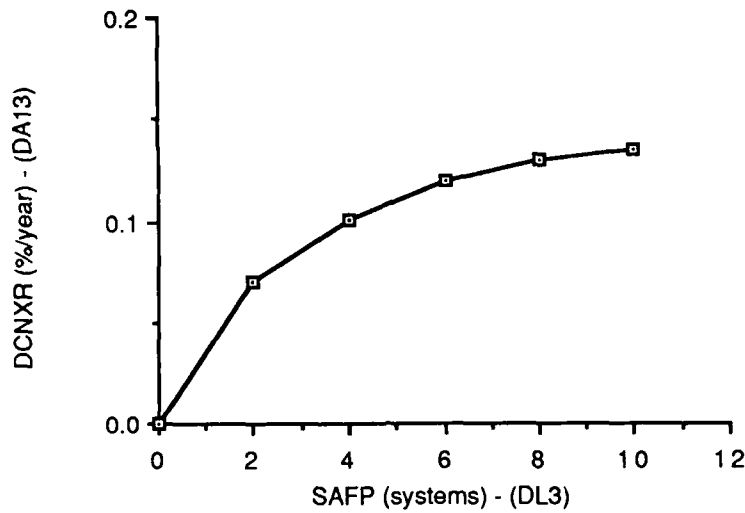

Figure 60. Structure for Systems Availability Effect on System Development Cancellation Rate

Systems which leave the system development pipeline are either cancelled or made available for production. Not all systems which are available for production are produced but this level provides a ceiling on the number of systems which can be produced. Systems which remain available for production are apt to become obsolete if a backlog exists. An obsolescence period of four years was chosen because this results in approximately 25% of the systems available for production becoming obsolete in a given year.

The number of systems which are brought into production in any given year is determined by the number of systems which are available and the number of systems which are desired based on an affordability assessment. The initial conditions have been set so that approximately three systems are put into production each year. This closely corresponds to the nearly 45 major

system production starts in 15 years reported by Peck and Scherer (1962, 645-667). The impact of affordability on desired production starts is determined by the current number of units being produced of each system (UPS) and the length of the production period (SPP). As the number of units per system declines or the production period gets longer the number of desired production starts declines. This relationship is shown in Figure 61.

L	$SAFP.K = SAFP.J + (DT * (DCR.JK - DSOR.JK - PST.JK))$	DL3
N	$SAFP = 5$	
	Note Systems Available For Production (systems).	
R	$SAFPRC.KL = DCR.K - DSOR.K - PST.K$	DR3
	Note Systems Available for Production Rate of Change (systems/year).	
A	$DSOR.K = SAFP.K / DSDR$	DA14
	Note Developed Systems Obsolesence Rate (systems/year).	
C	$DSDR = 4$	
	Note Developed Systems Depreciation Rate (years).	
A	$PST.K = \text{MIN}(DPST.K, SAFP.K)$	DA15
	Note Production Starts (systems/year).	
A	$DPST.K = \text{TABHL}(TDPST, UPS.K, 0, 300, 50) * (DSPP / SPP.K)$	DA16
T	$TDPST = .2, 1, 2, 2.6, 3, 3.3, 3.5$	
	Note Desired Production Starts (systems/year).	
C	$DSPP = 5$	
	Note Desired System Production Period (years).	

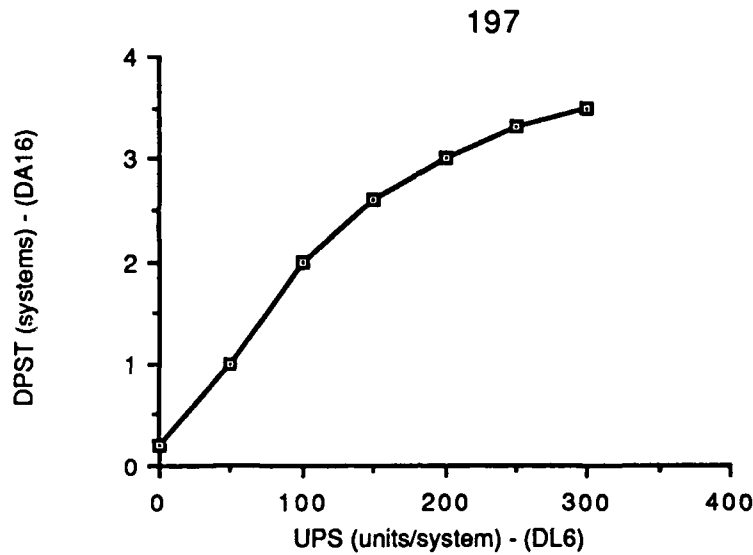

Figure 61. Structure for Desired Production Starts

The funds available for production of weapon system units in a given year (PFND) is determined by subtracting the annual cost of development for each system in development and government investment in plants and equipment from the annual weapon acquisition spending level (WASL). The annual cost of system development is determined by dividing the total system development cost (DCST) by the development period (SDP). The "development cost rate of change" is dependent upon two factors; the technology produced and the unit cost of systems produced. An initial development cost level of \$400 million over the life of the development period was chosen based on a level of \$2.3 billion in procurement funds programmed for development in 1959 (Peck and Scherer 1962, 26). This assumes 24 systems in development and a four-year development period. The relationship between the technology produced and its impact on development cost is shown in Figure 62.

A PFND.K=WASL.K-GINV.K-((SID.K*DCST.K)/SDP.K) DA17
 Note Production Funds (\$ billion/year).
 L DCST.K=DCST.J+(DT*DCRC.JK) DL4
 N DCST=.4
 Note Development Cost (\$ billion/system).
 R DCRC.KL=(TKE.J+UCSTE.J)*DCST.J DR4
 Note Development Cost Rate of Change (\$ billion/system/year)
 A TKE.K=TABHL(TTKE,TKPRO.K,0,5,1) DA18
 T TTKE=-.04,-.02,-.005,0,.01,.04 DT9
 Note Technology Effect on development costs (% change).

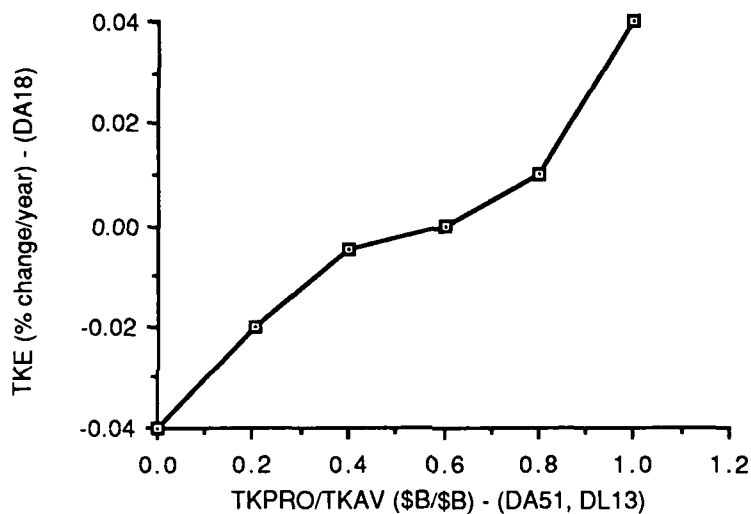

Figure 62. Structure for Weapon Technology Produced Effect on Development Cost

The impact of unit weapon cost on development cost is shown in Figure 63. The relationship between unit cost and development cost reflects the homogeneous treatment of the systems in the model. As unit cost goes up, the materials and components which drive the price up will also tend to drive up the price of the weapon systems being developed as follow-on systems.

A UCSTE.K=TABHL(TUCSTE,UCST.K/DCST.K,0,3.5,.5) DA19
 T TUCSTE=0,.03,.05,.06,.065,.0675,.069,.07 DT10
 Note Unit Cost Effect on development cost (% change).

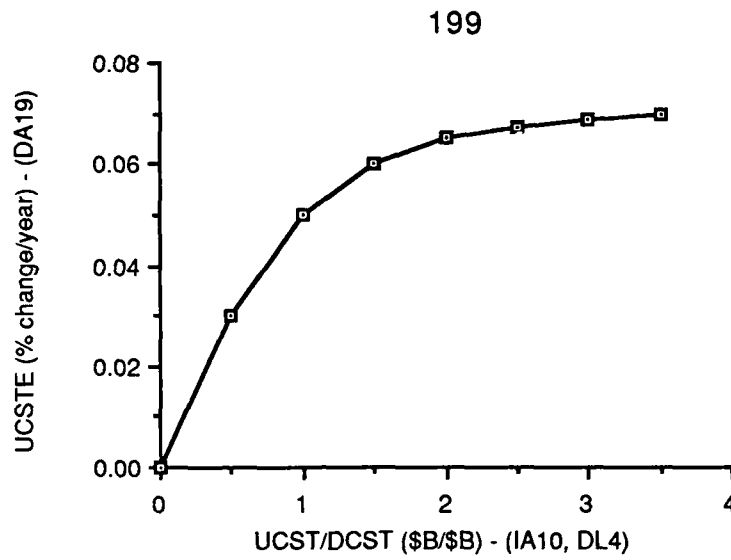

Figure 63. Structure for the Effect of Unit Cost on Development Cost

The level of systems in production (SIP) is increased when new production starts occur and is reduced when systems complete production or are cancelled. The total rate of change of the systems in production has been modeled so that a minimum of one system will always be in production. An initial level of 17 "systems in production" was chosen based on approximately three production starts per year (half of the six development starts) and a five and a half year production period (Smith and Friedmann 1980, 40). Production cancellations (PCNX) is, of course a variable under management's control and, therefore, is not modeled endogenously. Production completions are determined by the production period (SPP) which is simply the number of units produced for each system (UPS) divided by the annual production rate (PROR) in units per year. The annual production rate (PROR) is a function of affordability and industry capacity. Production capacity (CAPL) places an upper

limit on the production rate. Otherwise the production rate is determined by the funding available and the unit cost of the weapon systems. That is as many systems are produced as there is money available in a given year.

L	$SIP.K = SIP.J + (DT * (PST.JK - PCNX.JK - PCOM.JK))$	DL5
N	$SIP = 17$	
	Note Systems In Production (systems).	
R	$SIPRC.KL = (PST.K - PCNX.K - PCOM.K) * ((SIP.K - 1) / SIP.K)$	DR5
	Note Systems in Production Rate of Change (systems/year).	
A	$PCNX.K = SIP.K * PCR$	DA20
	Note Production Cancellations (systems/year).	
C	$PCR = 0$	
	Note Production Cancellation Rate (% systems cancelled each year).	
A	$PCOM.K = SIP.K / SPP.K$	DA21
	Note Production Completion rate (systems/year).	
A	$SPP.K = UPS.K / PROR.K$	DA22
	Note System Production Period (years).	
A	$PROR.K = \text{MIN}(CAPL.K, FEPR.K)$	DA23
	Note Production Rate (units/system/year).	
A	$FEPR.K = PFND.K / (SIP.K * UCST.K)$	DA24
	Note Funding Effect on Production Rate (units/system/year)	

Production capacity, which is determined in the industry sector model, is measured in billions of dollars of production per year. The total annual production for the Department of Defense is added to annual level of foreign military sales to determine the amount of production capacity used. The annual production rate is restricted from surpassing the industry capacity.

A	$CAPL.K = (ICAP.K - FMS.K) / (PRCST.K * SIP.K)$	DA25
	Note Capacity Limitation on production rate (units/system/year).	

The number of units of each weapon system which are produced throughout the production period is determined by affordability alone rather than taking into account any threat assessment. The relationship between the

number of units produced of each system (UPS) and unit cost, and between systems in production and available funds indicates that the number of units per system is based on the difference between current unit cost, number of systems in production and the available funds and the three year lagged values of these variables. The decision of how many units of each weapon system will be produced is made early on during the production cycle and is based on the available information concerning unit costs, which is only known for systems well along in the acquisition process. The result is that the decision on units per system is based on three year old information and a ten percent increase in unit cost, will result in something less than a ten percent decrease in the number of units produced per system. The impact of the production period on units produced per system is such that as the production period becomes longer than 7.5 years that the units produced per system is reduced. The relationship between production period and the units produced per system can be seen in Figure 64.

L	$UPS.K = UPS.J + DT * UPSRC.JK$	DL6
N	$UPS = 265$	
	Note Units Produced per System (units/system).	
R	$UPSRC.KL = (FNDE.K + SPPE.K) * (UPS.K - 1)$	DR6
	Note Units per System Rate of Change (units/system/year).	
A	$FNDE.K = (UPSF.K - SUPSF.K) / (5 * SUPSF.K)$	DA26
	Note Funding Effect on Units Per System Rate of Change (% change/year)	
A	$UPSF.K = PFND.K / (SIP.K * UCST.K)$	DA27
	Note Units Per System Factor (units/system)	
A	$SUPSF.K = DLINF3(UPSF.K, 3)$	DA28
	Note Smoothed UPSF (units/system)	
A	$SPPE.K = TABHL(TSPP, SPP.K, 7.5, 10, .5)$	DA29
T	$TSPP = 0, -.002, -.005, -.01, -.02, -.04$	DT11
	Note System Production Period Effect on Units Per System Rate of	
	Note Change (% change/year).	

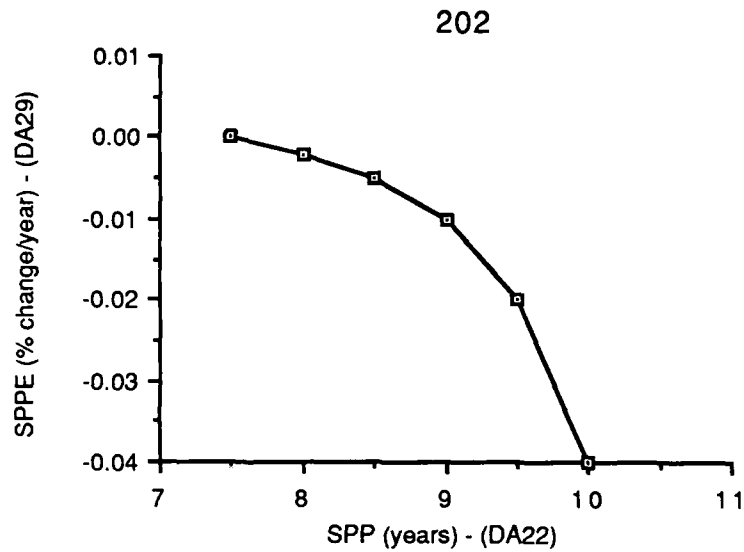

Figure 64. Structure for System Production Period Effect on Units Per System

Readiness Structure

The level of readiness (RED) is a three dimensional concept which reflects the quality of military personnel, the level of force maintainability, and the level of the stock of spares and munitions. Personnel quality is a function of the input quality of recruits, the rate of personnel attrition and the amount of training which occurs annually. The structure of the readiness subsector is shown in Figure 65.

Each of the components of readiness is depreciated individually so that there is no aggregated readiness depreciation as there was with the weapon inventory. The rate of change of readiness is determined by the differential between each of the components and its desired level, which are functions of global tension. An initial level of readiness of \$30 billion was chosen based on experimentation with the model to determine the aggregate impact of

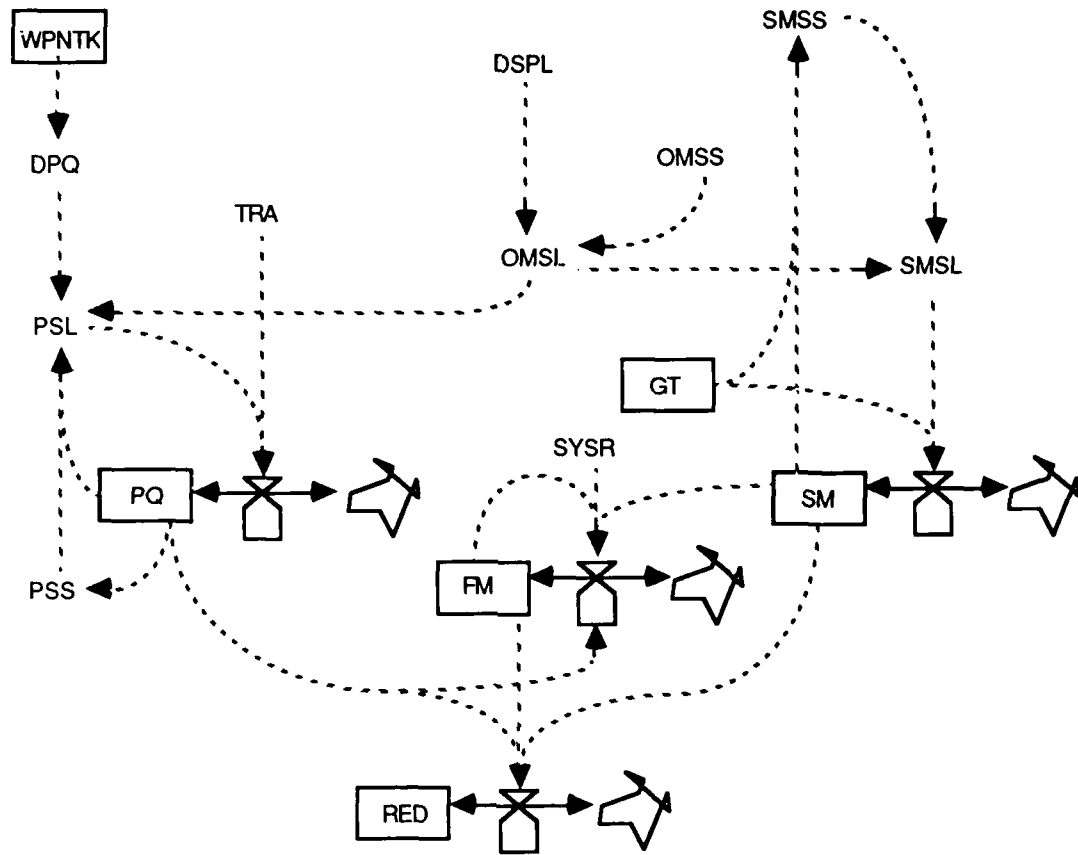

Figure 65. Defense Sector Modified Flow Diagram: Readiness Structure

Table 4. -- Figure 65 Key

VARIABLE	NAME	MEASURE
DPQ	Desired Personnel Quality	\$1000/person
DSPL	Defense Spending Level	\$ billion/year
FM	Force Maintainability	% mission capable
GT	Global Tension	global tension units
OMSL	O&M Spending Level	\$ billion/year
OMSS	O&M Spending Share	%
PQ	Personnel Quality	\$1000/person
PSL	Personnel Spending Level	\$ billion/year
PSS	Personnel Spending Share	%
RED	Readiness Level	\$ billion
SM	Spares and Munitions Stock	\$ billion
SMSL	Spares and Munitions Spending Level	\$ billion/year
SMSS	Spares and Muntions Spending Share	%
SYSR	System Reliability	% mission capable
TRA	Training Level	\$ billion/year

depreciation of the three dimensions of readiness. An initial spending level of approximately \$15 billion per year and an approximately two year aggregate depreciation rate leads to a \$30 billion initial equilibrium level.

L	$RED.K = RED.J + (DT * REDRC.JK)$	DL6
N	$RED = 30$	
Note	US Readiness level (\$ billion).	
R	$REDRC.KL = (PQF.K + FMF.K + SMF.K) * RED.K$	DR6
Note	Readiness Rate of Change (\$ billion/year).	

The effect of personnel quality on the rate of change of the readiness level is dependent upon the difference between actual personnel quality, measured in \$1000 of quality/man, and the desired level of personnel quality, which is a function of weapon technology. Personnel quality is influenced by the quality of the personnel attracted to the military, which is largely a function of compensation, and the level of training. These relationships are described in detail below. The relationship between personnel quality, desired personnel quality and readiness change is shown in Figure 66.

A	$PQF.K = TABHL(TPQF, PQ.K - DPQ.K, -3, 3, 1)$	DA30
T	$TPQF = -.3, -.15, -.06, 0, .03, .08, .15$	DT12
Note	Personnel Quality Factor (% change/year).	

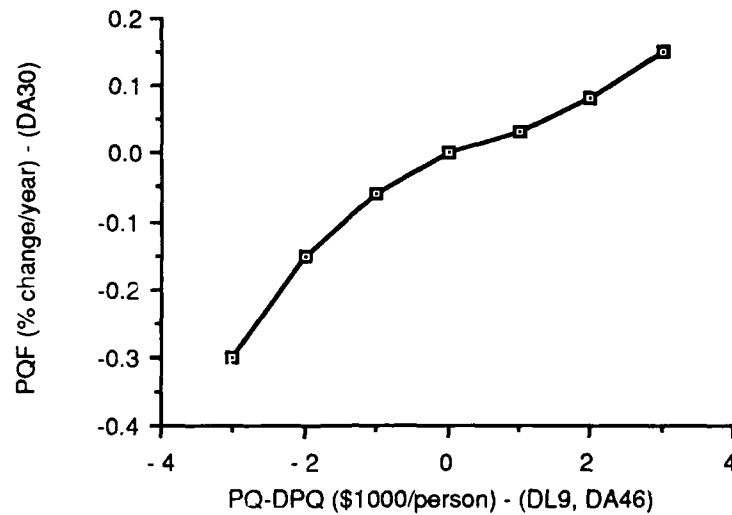

Figure 66. Structure of Personnel Quality Differential Effect on Readiness Change

The relationship between force maintainability and readiness change is shown in Figure 67. The table function indicates that readiness is affected adversely to a greater degree by poor reliability and maintainability than it is affected positively by good maintainability. This is largely because the desired maintainability levels and actual mission capable rates are closer to 100% than 50% and so not much upside impact is possible (Comptroller of the Air Force 1986).

A FMF.K=TABHL(TFMF,FM.K-DFM.K,-.5,.5,.2)
 T TFMF=-.3,-.1,-.01,.01,.03,.08
 Note Force Maintainability Factor (% change/year).

DA31
 DT13

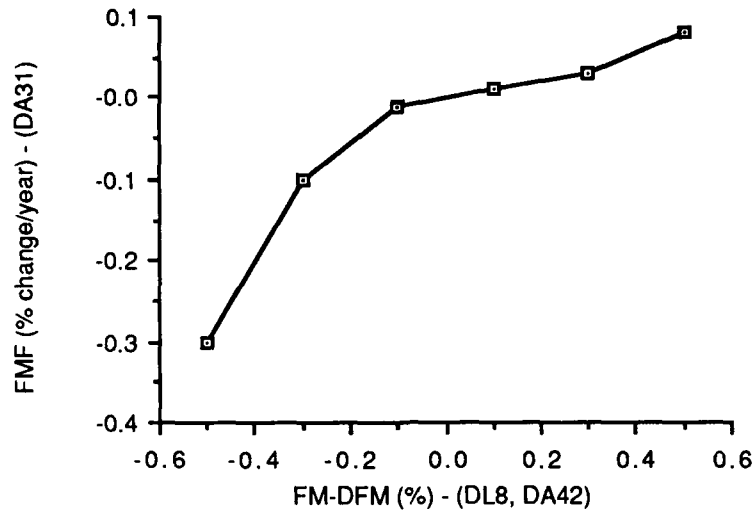

Figure 67. Structure for Force Maintainability Differential Effect on Readiness Change

The relationship between the stock of spares and munitions (SM) and readiness change is shown in Figure 68. The table function reflects that the down side to not having enough spares and munitions is larger than is the upside where more than the desired stocks are held. There is some advantage to having excess stocks but the relationship is not symmetrical about zero. The table function reflects that when a severe shortage in spares exists that force maintainability could fall as much as 30% in a given year.

A SMF.K=TABHL(TSMF,SM.K-DSM.K,-3,3,1)

T TSMF=-.3,-.15,-.06,0,.03,.08,.15

Note Spares and Munitions Factor (% change/year).

DA32

DT14

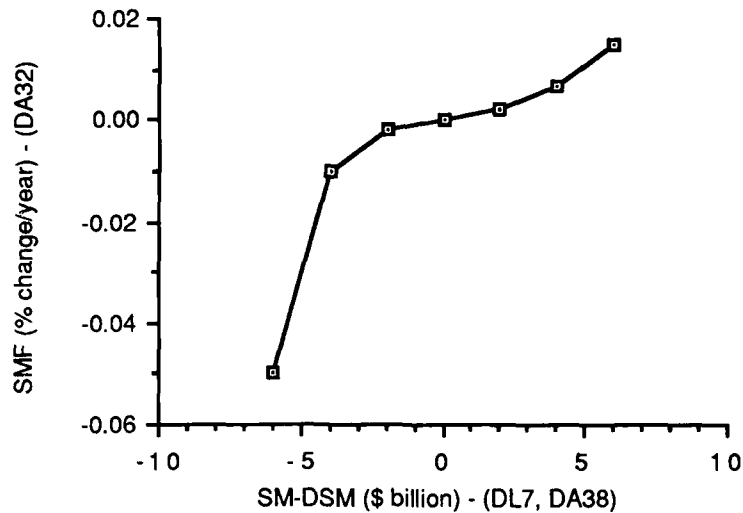

Figure 68. Structure for the Effect of Spares and Munitions Stock Differential on Readiness Change

The level of the spares and munitions stock is increased as money is spent for them and is depleted by operations. The level of operations, and the spares and munitions depletion rate, is determined by the global tension level and the training level. An initial level of \$12 billion in spares and munitions was chosen based on an initial annual spending level of four billion dollars and an initial three year depletion rate. The relationship between the spares and munitions depletion rate, in years, and the operations level is shown in Figure 69. These depreciation rates reflect a compromise between the relatively rapid use of spares during peace time with the relatively slow use of munitions. During periods of higher tensions the rate of use of both components is relatively rapid.

L $SM.K = SM.J + (DT * SMRC.JK)$

DL7

N $SM = 12$

Note Spares and Munitions stock level (\$ billion).

R $SMRC.KL = SMSL.K - (SM.K / SMDR.K)$

DR7

Note Spares and Munitions Rate of Change (\$ billion/year).

A $SMDR.K = TABHL(TSMDR, GT.K + TRAM.K, 0, 100, 25)$

DA33

T $TSMDR = 10, 4, 2, 1, .5$

DT15

Note Spares and Munitions Depreciation Rate (years).

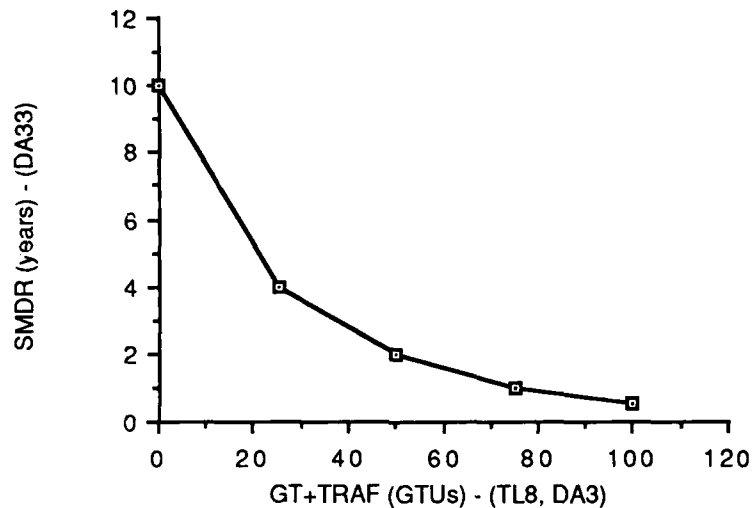

Figure 69. Structure for Level of Operations Effect on Spares and Munitions Depletion

The rate at which the spares and munitions stock is increased is directly related to the spending level. The annual expenditures on spares and munitions (SMSL) is determined by multiplying the spares and munitions share by the operations and maintenance expenditures. The spares and munitions spending share (SMSS) of the operations, maintenance, and personnel annual expenditures (OMSL) is determined by comparing the spares and munitions stock with the desired stock. This relationship is shown in Figure 70. The desired spares and munitions stock is a function of global tension. As global

tension rises the desired level of spares and munitions increases in order to deal with the possible conflicts resulting from the rising tensions. The operations and maintenance (O&M) spending level is determined by the O&M spending share of the total defense expenditures and the level of defense expenditures. The O&M spending share (OMSS) is determined as a result of the other component spending shares which are based on independent threat assessments. As a result the O&M accounts will be funded at minimum levels during periods when each of the other shares are maximized due to perceived shortfalls in either weapon inventory, weapon technology, or intelligence resolution.

A	$SMSL.K = OMSL.K * SMSS.K$	DA34
Note	Spares and Munitions Spending Level (\$ billion/year).	
A	$OMSL.K = OMSS.K * DSPL.K$	DA35
Note	O&M Spending Level (\$ billion/year).	
A	$OMSS.K = 1 - RDSS.K - WASS.K - IRSS.K$	DA36
Note	O&M Spending Share (%) of annual defense expenditures.	
A	$SMSS.K = TABHL(TSMSS, DSM.K - SM.K, 0, 5, 1)$	DA37
T	$TSMSS = .22, .25, .27, .28, .287, .29$	DT16
Note	Spares and Munitions Spending Share of O&M spending level (%).	

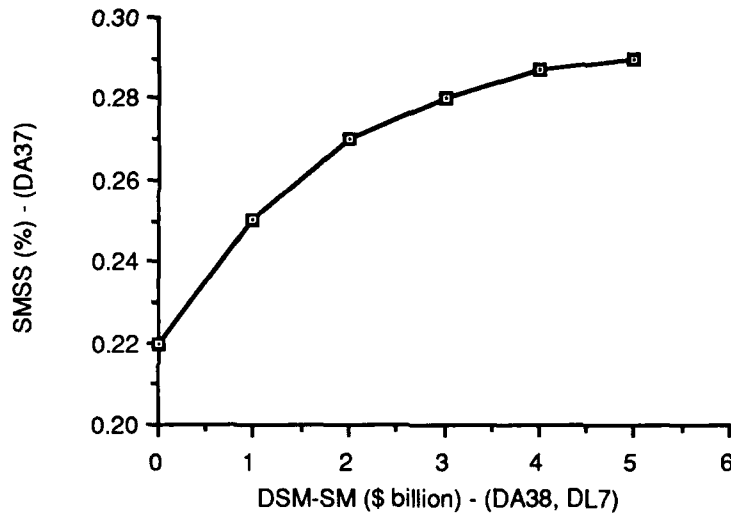

Figure 70. Structure of Spares and Munitions Differential Effect on Spares and Munitions Spending Share

The desired level of the spares and munitions stock is a function of the global tension level. This relationship is shown in Figure 71. The table function indicates a steadily increasing desired stock as global tension increases with a higher rate of increase or decrease at extreme levels of global tension. Information concerning the current size of the United States' stock of spares and munitions is not readily available. These table function values were determined using the approximate annual expenditure levels (Comptroller of the Air Force 1986) and the depreciation rates shown previously in DT15.

A DSM.K=TABHL(TDSM,GT.K,0,100,25)

T TDSM=8,14,15,16,22

Note Desired Spares and Munitions level (\$ billion).

DA38

DT17

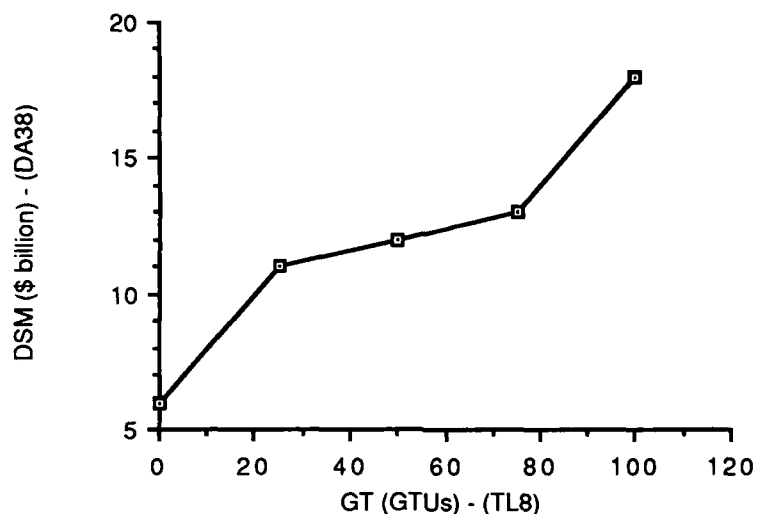

Figure 71. Structure for Global Tension Effect on Desired Spares and Munitions

Force maintainability has three dimensions which account for the impact of weapon system availability on military capability. If the systems tend to break down, take a long time to fix, or there are no spare parts, readiness is adversely affected. The three dimensions of force maintainability, therefore, are spares and munitions stock availability, system reliability, and personnel quality which impacts maintenance effectiveness. The three terms are additive. The impact of spares and munitions on force maintainability rate of change is shown in Figure 72.

$$L \text{ FM.K} = \text{FM.J} + (\text{DT} * \text{FMRC.JK})$$

DL8

$$N \text{ FM} = .8$$

Note Force Maintainability force multiplier(%).

$$R \text{ FMRC.KL} = (\text{SMFM.K} + \text{SRFM.K} + \text{PQFM.K}) * (1 - \text{FM.K})$$

DR8

Note Force Maintainability Rate of Change (%/year).

$$A \text{ SMFM.K} = \text{TABHL}(\text{TSMFM}, \text{DSM.K} - \text{SM.K}, 0, 5, 1)$$

DA39

$$T \text{ TSMFM} = .01, .003, 0, -.003, -.01, -.05$$

DT18

Note Spares and Munitions effect on Force Maintainability (% change/year).

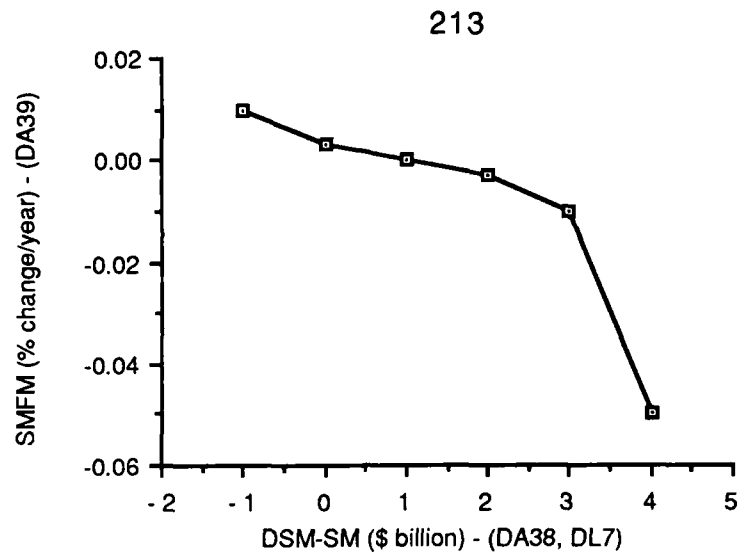

Figure 72. Structure for Spares and Munitions Effect on Maintainability

The effect of system reliability on force maintainability is a function of the difference between system reliability and force maintainability, and the value of new weapon system production. System reliability reflects the current reliability of new systems being added to the force and so its impact on overall force maintainability is slow. The impact is determined by the difference between current reliability and maintainability and the value of the weapons which are added to the inventory in the current year.

$$A \text{ SRFM.K} = (\text{SYSR.K} - \text{FM.K}) * (\text{PFND.K} / \text{WPNIN.K})$$

Note System Reliability effect on Force Maintainability (% change/year).

The impact of personnel quality on force maintainability is determined by the difference between personnel quality and the desired level of personnel quality, which is a function of weapon technology. Higher levels of weapon technology level dictates that a higher level of personnel quality is necessary.

When the desired level of personnel quality rises relative to the current level of personnel quality the impact is a reduction in the force maintainability level. The relationship is shown in Figure 73. Once again a personnel quality level which exceeds the desired level has less positive marginal impact than when the personnel quality level is lower than the desired level. The particular values in the table function were derived in conjunction with the other table functions impacting "force maintainability rate of change" in order to reproduce a stable level of force maintainability which reacted to overall levels of O&M spending.

A PQFM.K=TABHL(TPQFM, DPQ.K-PQ.K, -2,10,2)

DA41

T TPQFM=.02,.005,0,-.005,-.02,-.05,-.1

DT19

Note Personnel Quality effect on Force Maintainability (% change/year).

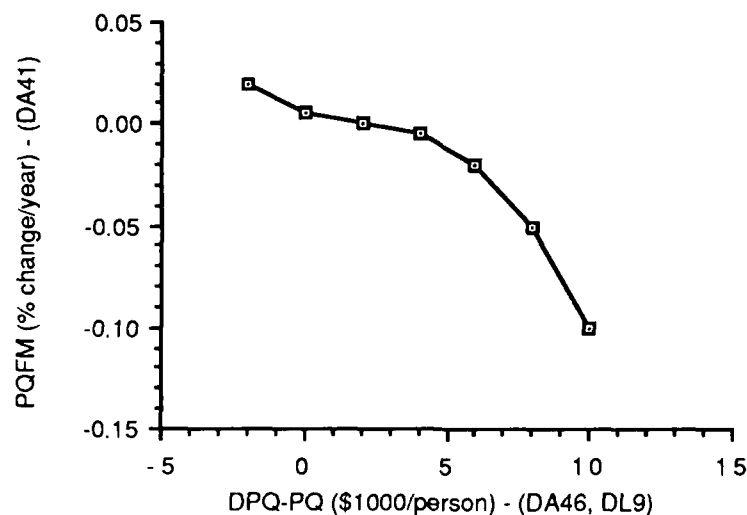

Figure 73. Structure for Personnel Quality Differential Effect on Maintainability

The desired force maintainability level (DFM) and the actual level of force maintainability together determine the impact of force maintainability on overall

readiness. The desired level of force maintainability is determined as a function of global tension. The premise is that the closer the United States gets to hostilities, higher levels of maintainability and readiness are desired. The relationship between global tension and the desired level of maintainability is shown in Figure 74.

A DFM.K=TABHL(TDFM, GT.K,0,100,25)
 T TDFM=.5,.7,.85,.9,.95
 Note Desired Force Maintainability (%).

DA42
 DT20

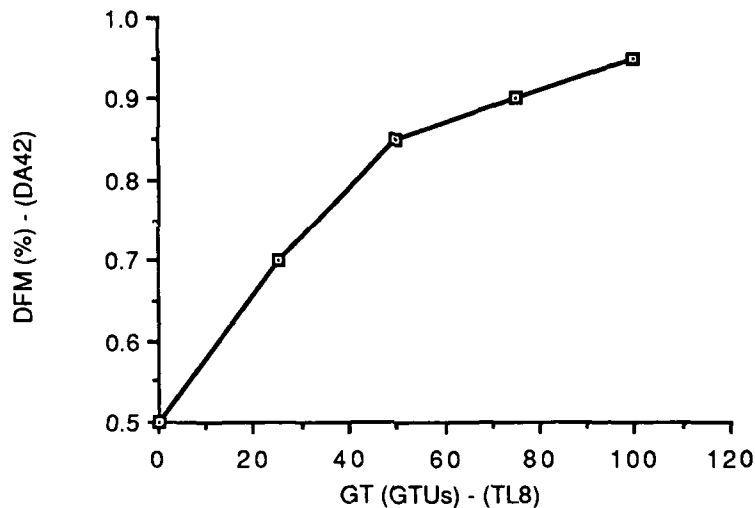

Figure 74. Structure for Global Tension Effect on Desired Maintainability

The third component of readiness is the personnel quality level. Personnel quality in the model is measured in \$1000/person of quality. This operationalization reflects the limited structure used in the model which includes only the monetary effects on personnel accessions and retention. This structure is consistent with the rest of the model. Personnel quality impacts the

operational effectiveness of the military as well as the maintenance effectiveness. The level of personnel quality in the model is impacted positively by the level of quality of new recruits, the retention of recruits, and by the training which is experienced while in the service. The input quality-level of new recruits is dependent, of course, upon many factors. The model, however, only reflects the economic impact of the aggregate wage. As per capita compensation increases so does the quality level of new recruits, and conversely, as compensation goes down so will input personnel-quality. The retention of recruits is also a complex process which is affected mostly strongly by monetary reimbursement. Both of these effects are modeled using the per capita wage. The impact of per capita compensation on personnel quality is shown in Figure 75. An initial level of personnel quality was chosen using experimentation with the model to determine what level of personnel quality is sustainable in equilibrium conditions. The shape of the table function indicates that marginal increases in the per capita personnel spending level have a declining impact upon the personnel quality level. Also relatively low wages result in more rapid personnel quality decline than is able to be made up with relatively high wages. This reflects the fact that attrition from the force cannot be compensated for with higher levels of accession because the attrition comes from higher experienced personnel who cannot be immediately replaced.

L $PQ.K = PQ.J + DT * PQRC.JK$

DL9

N $PQ = 11$

Note Personnel Quality level (\$1000/person).

R $PQRC.KL = (WIMP.K + TIMP.K) * PQ.K$

DR9

Note Personnel Quality Rate of Change (\$1000/person/year).

A $WIMP.K = TABHL(TWIMP, PSL.K / FS.K, 2, 6, 1)$

DA43

T $TWIMP = -.03, -.01, 0, .01, .015$

DT21

Note Wage Impact on Military Personnel quality input level (% change).

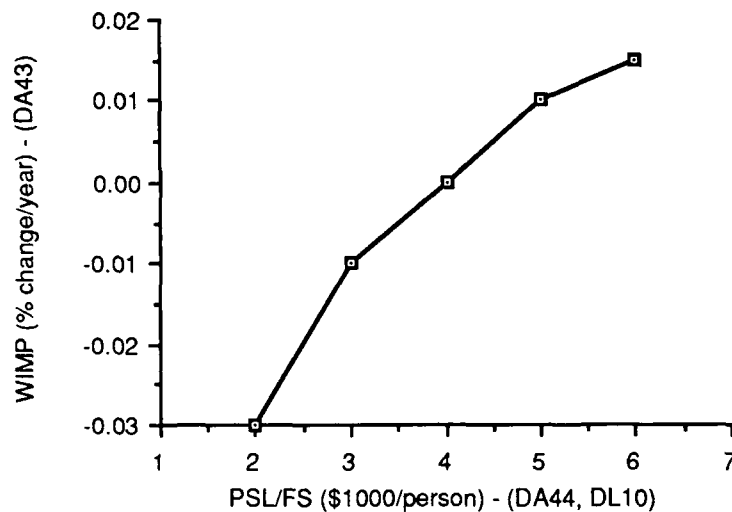

Figure 75. Structure for Personnel Spending Level Effect on Personnel Quality

The total annual expenditures on personnel (PSL) is determined by multiplying the personnel share (PSS) by the O&M/Personnel spending level (OMSL). The personnel spending share is determined by the difference between the current personnel quality level and the desired level. This relationship is shown in Figure 76 and reflects actual spending levels (Comptroller of the Air Force 1986).

A $PSL.K = PSS.K * OMSL.K$

DA44

Note Personnel Spending Level (\$ billion).

A $PSS.K = TABHL(TPSS, DPQ.K - PQ.K, -3, 3, 1)$

DA45

T $TPSS = .4, .47, .51, .54, .55, .57, .6$

DT22

Note Personnel Spending Share (% of O&M/P spending level).

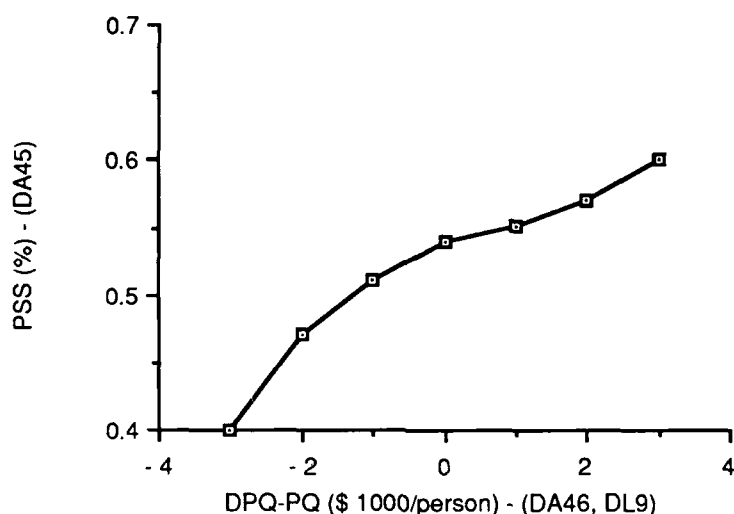

Figure 76. Structure for Personnel Quality Differential Effect on Personnel Spending Share

The desired personnel quality level (DPQ) is a function of weapon technology. As the weapon technology level rises the quality of the personnel needed to maintain and operate the weapon systems effectively increases. The relationship between weapon technology and desired personnel quality is shown in Figure 77. The table function reflects a minimum desired quality level of \$7500 per person which increases slowly at first and then increases more rapidly to a maximum of \$15000 per person. These values were derived in conjunction with the other table functions which impact personnel quality in

order to ensure compatibility with the Comptroller of the Air Force report (1986).

A $DPQ.K = TABHL(TDPQ, WPNTK.K, 0, 20, 5)$

T $TDPQ = 7.5, 8, 9, 11, 15$

Note Desired Personnel Quality level (\$1000/person).

DA46

DT23

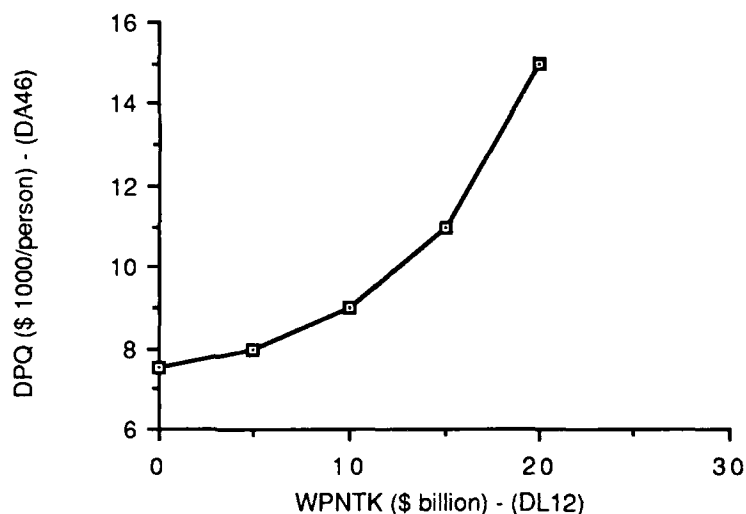

Figure 77. Structure for Weapon Technology Effect on Desired Personnel Quality

The size of the military forces (FS) is a level which is increased or decreased as a function of the size of the weapon inventory (WIS). The weapon inventory size is a variable which reflects the aggregate size of the weapon inventory in terms of units (e.g. ships, tanks, aircraft, etc) rather than in dollar terms. The initial force level reflects the approximately 2.5 million people on active duty in 1961 (Luttwak 1984, 296). The desired force size (DFS) is determined by the weapon inventory size, and the rate of change of the force is determined by the difference between the current force size and the desired force size. A five year delay has been built in to reflect the speed at which

changes in the force can be implemented due to enlistment periods and other factors. The relationship between the weapon inventory size and the desired force size is shown in Figure 78. The table function shows the basic relationship between inventory size and desired personnel, as the inventory size declines so does the desired force size. The specific values were chosen in order to replicate the actual decline in force size which has occurred since 1960.

L	$FS.K=FS.J+(DT*FSRC.JK)$	DL10
N	$FS=2.5$	
Note	Force Size (millions of active duty military personnel).	
R	$FSRC.KL=(DFS.K-FS.K)/5$	DR10
Note	Force Size Rate of Change (millions of persons/year).	
A	$DFS.K=TABHL(TFS,WIS.K,0,40000,10000)$	DA47
T	$TFS=1.5,1.6,1.8,2.2,2.8$	DT24
Note	Desired Force Size (millions).	
L	$WIS.K=WIS.J+(DT*WISRC.JK)$	DL11
N	$WIS=35000$	
Note	Weapon Inventory Size (units).	
R	$WISRC.KL=(PROR.K*SIP.K)-(WIS.K/USWDR.K)$	DR11
Note	Weapon Inventory Size Rate of Change (units/year).	

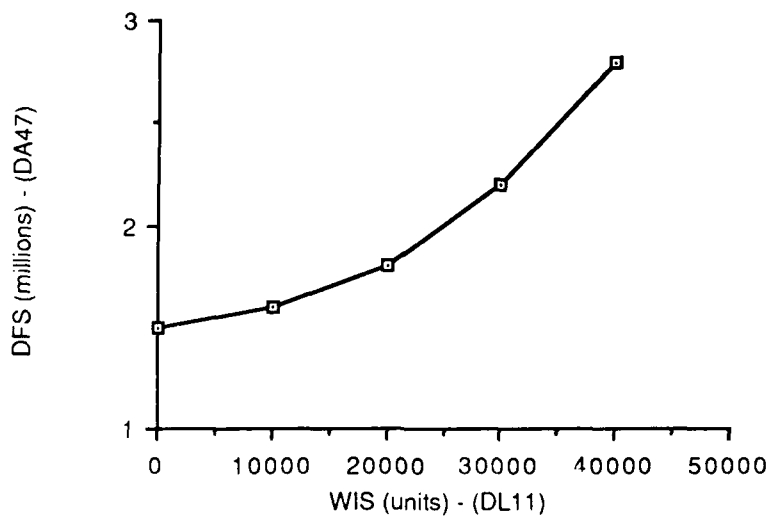

Figure 78. Structure for Weapon Inventory Size Effect on Desired Force Size

The impact of training on personnel quality is determined by the annual training expenditures (TRA) and the force size. The relationship reflects that training expenditures of \$3000 per person results in no increase or decrease in personnel quality. This value and those in the table function were chosen in conjunction with other model parameters in order to replicate the actual levels of training expenditures (Comptroller of the Air Force 1986). Training expenditures below this level result in relatively rapid decay in personnel quality. The relationship between training expenditures, force size, and personnel quality is shown in Figure 79. The annual training expenditures (TRA) are determined by multiplying the training share of the O&M expenditures (TRAS) by the annual O&M spending level (OMSL). The training share is that part of the O&M expenditures that are left over after the personnel and spares and munitions shares are determined.

A	$TIMP.K = TABHL(TTIMP, TRA.K/FS.K, 0, 6, 1)$	DA48
T	$TTIMP = -.03, -.015, -.005, 0, .005, .007, .008$	
	Note Training Impact on Personnel quality (% change/year)	
A	$TRA.K = TRAS.K * OMSL.K$	DA43
	Note Training Level, annual expenditures (\$ billion/year)	
A	$TRAS.K = 1 - PSS.K - SMSS.K$	DA44
	Note Training Share of O&M annual expenditures (%).	

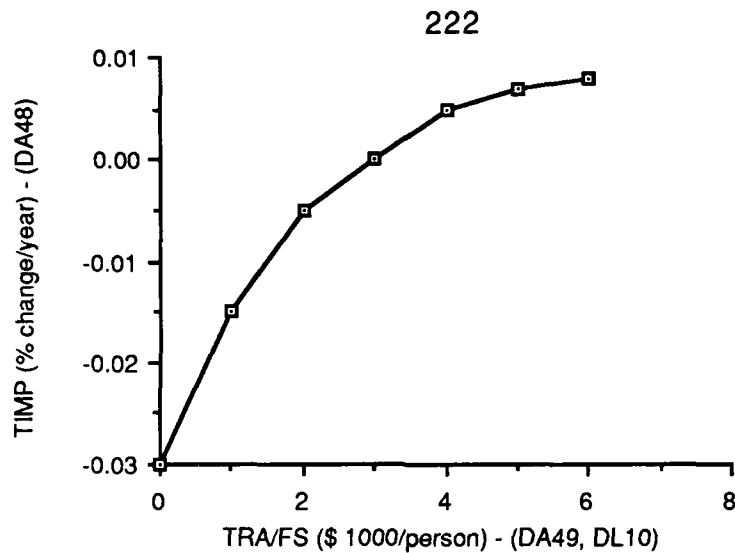

Figure 79. Structure for Training Effect on Personnel Quality

Weapon Technology Structure

The third component of military capability is weapon technology. The level of weapon technology is a relative measure which reflects the technologies embedded in the production of new weapons. The weapon inventory, with its technology multiplier, reflects the long-term technology accumulation. Weapon technology is increased as a result of research and development and decreases due to technological advancement in general and Soviet weapon technology specifically. The structure for the weapon technology subsector is shown in Figure 80.

The weapon technology produced is determined by the level of technology available which results from research and development spending and the level of system reliability. The technology available level places a ceiling on the technology which is produced. The initial level of weapon technology is based on initial annual R&D expenditures of approximately \$4.5 billion and a four year

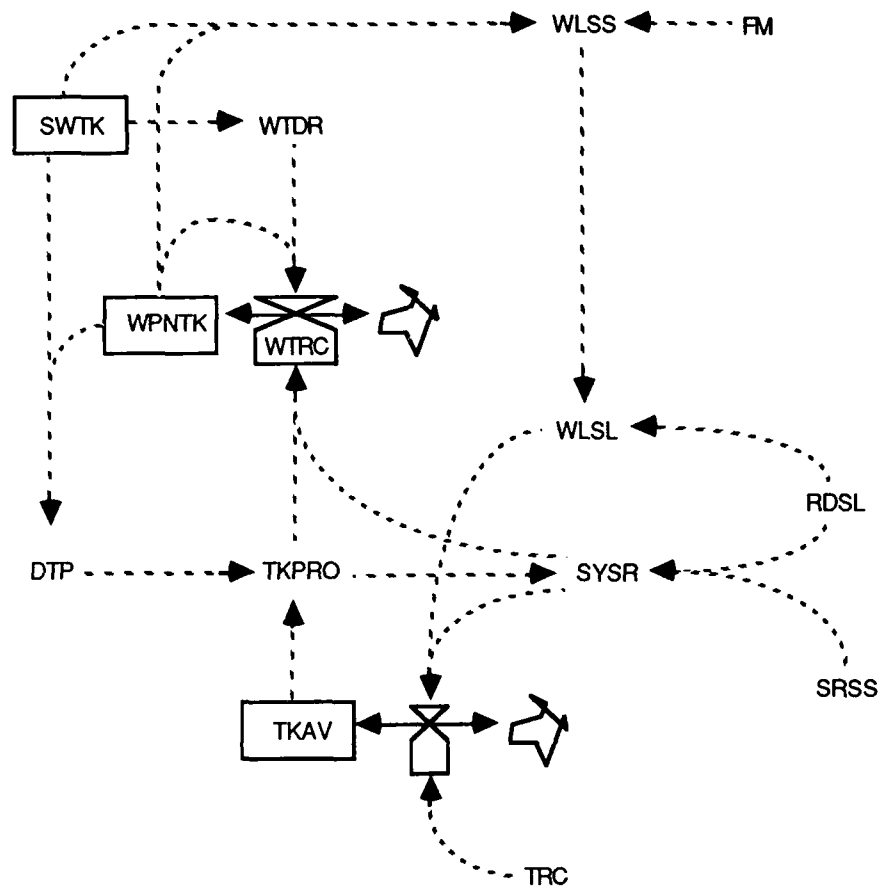

Figure 80. Defense Sector Modified Flow Diagram: Weapon Technology Structure

Table 5. -- Figure 80 Key

VARIABLE	NAME	MEASURE
DTP	Desired Technology Produced	\$ billion
FM	Force Maintainability	% mission capable
RDSL	R&D Spending Level	\$ billion/year
SRSS	System Reliability Spending Share	%
SWTK	Soviet Weapon Technology	\$ billion
SYSR	System Reliability	% mission capable
TKAV	Technology Available	\$ billion
TKPRO	Technology Produced	\$ billion
TRC	Technological Rate of Change	years
WLSL	Weapon Lethality Spending Level	\$ billion/year
WLSS	Weapon Lethality Spending Share	%
WPNTK	Weapon Technology Level	\$ billion
WTDR	Weapon Technology Depletion Rate	years
WTRC	Weapon Technology Rate of Change	\$ billion/year

depreciation rate.

The level of technology available (TKAV) includes system lethality technologies. System reliability technologies are modeled separately and used as a multiplier of technology produced. The technology available level increases with spending on weapon lethality technologies and decreases with time due to the technological rate of change. The initial level of technology available (TKAV) was chosen based on experimentation with the model to determine a sustainable level based on equilibrium conditions and a 4.5 year depletion rate. The technological rate of change is dependent upon the relative levels of Soviet and United States weapon technology levels. The higher the Soviet level of technology relative to the United States, the faster the technology is depleted and vice versa. This relationship is shown in Figure 81.

L	$WPNTK.K = WPNTK.J + (DT * WTRC.JK)$	DL12
N	$WPTNK = 18$	
Note	US Weapon Technology level (\$ billion).	
R	$WTRC.K = (TKPRO.K * SYSR.K) - (WPNTK.K / WTDR.K)$	DR12
Note	Weapon Technology Rate of Change (\$ billion/ year).	
A	$TKPRO.K = \min(DTP.K, TKAV.K)$	DA51
Note	Technology Produced (\$ billion/year).	
L	$TKAV.K = TKAV.J + (DT * TKAVRC.JK)$	DL13
N	$TKAV = 10$	
Note	Technology Available (\$ billion).	
R	$TKAVRC.KL = (WLSL.K * LTSE) - (TKAV.K / TRC.K)$	DR13
Note	Technology Available Rate of Change (\$ billion/year).	
C	$LTSE = .6$	
Note	Lethality Technology Spending Efficiency (%)	
A	$TRC.K = TABHL(TTRC, WPNTK.K / SWTK.K, 0, 5, 1)$	DA52
T	$TTRC = 3.5, 4.2, 4.5, 4.7, 4.8, 4.85$	DT26
Note	Technological Rate of Change (years).	

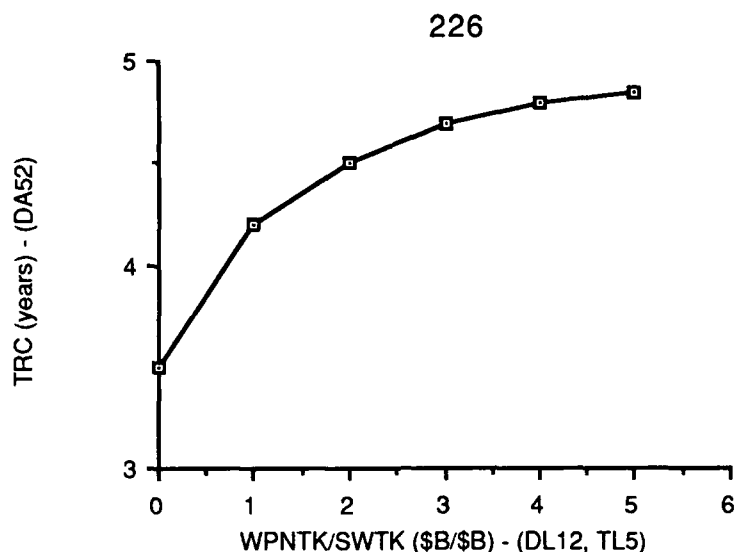

Figure 81. Structure for Relative Weapon Technology Effect on Technological Rate of Change

The annual expenditures on research and development (RDSL) is determined by the research and development (R&D) spending share (RDSS) and the annual defense expenditures. The R&D spending share is determined by the perceived weapon inventory ratio. The United States uses weapon technology as a counter to the numerically superior forces of the Soviet Union, and so R&D pressures come from a comparison of the technology weighted weapon inventories rather than from an assessment of the Soviet's weapon technology alone. This relationship is shown in Figure 82.

A $RDSL.K = RDSS.K * DSPL.K$

DA53

Note Research and Development Spending Level (\$ billion/year).

A $RDSS.K = TABHL(TRDSS, WPNIN.K / (USIAC.K * SWPN.K), 0, 5, 1)$

DA54

T $TRDSS = .15, .12, .1, .09, .085, .083$

DT27

Note Research and Development Spending Share (%) of annual

Note defense expenditures.

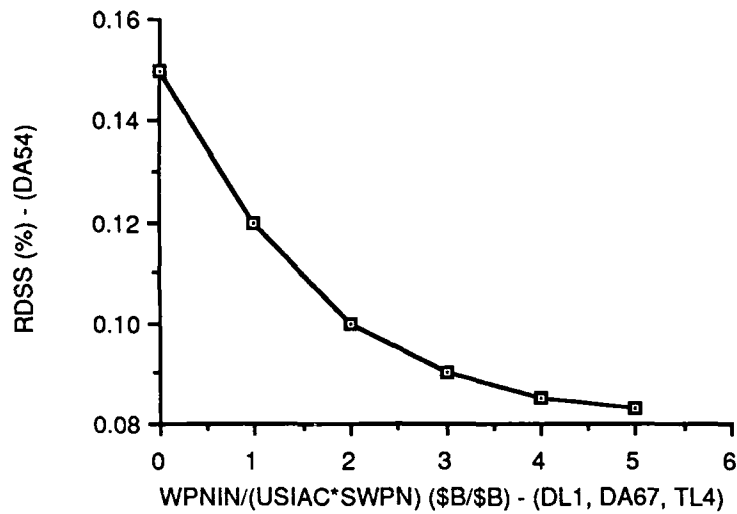

Figure 82. Structure for Perceived Weapon Inventory Ratio Effect on R&D Spending Share

As with the Soviet weapon technology level, which was defined in the threat sector, United States weapon technology is a relative concept. The depletion rate of weapon technology, therefore, is dependent on the relation between the Soviet and United States weapon technology levels. This relationship is shown in Figure 83. The parameters have been chosen in conjunction with those in the threat sector to reflect the slow but steady decline in the technological advantage of the United States that has occurred since 1960 (Defense Science Board 1987).

A WTDR.K=TABHL(TWTDR,WPNTK.K/SWTK.K,0,5,1)

T TWTDR=3.1,3.8,4.1,4.3,4.7,5.2

Note Weapon Technology Depletion Rate (years).

DA55

DT28

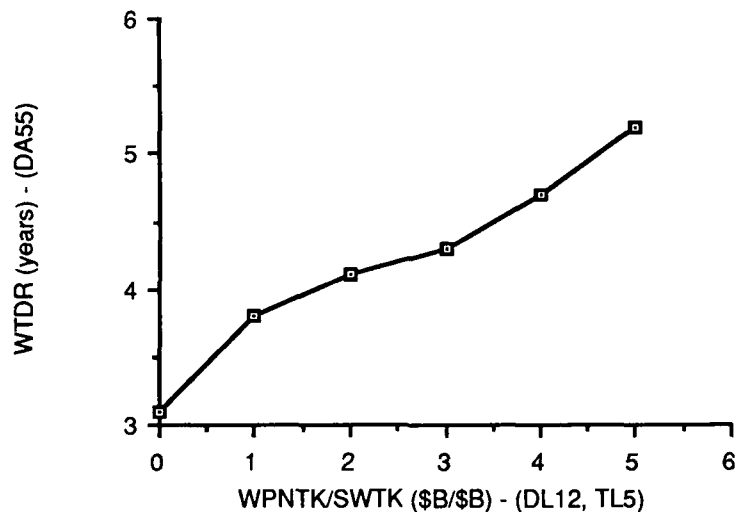

Figure 83. Structure for Weapon Technology Ratio Effect on Weapon Technology Depletion Rate

The system reliability level, which is an important component of weapon technology, is a measure of how often a weapon system is available for operational use, or conversely, how often it breaks down. System reliability is increased as the the level of R&D spending directed at system reliability (SRSL) increases relative to the level of technology being produced. This formulation reflects the notion that highly lethal weapons can be very unreliable unless reliability is a design criterion. The relationship between system reliability level change and expenditures and technology produced is shown in Figures 84 and 85. The CLIP function has been used because increases in reliability are more difficult the nearer the system reliability is to one, just as decreases in reliability are more difficult when system reliability is close to zero. The CLIP function allows for different system reliability rates of change depending on whether the reliability is greater than or less than 0.5.

L $SYSR.K = SYSR.J + DT * SYSRRC.JK$ DL14
 N $SYSRC = .7$
 Note System Reliability (OR rate) of new weapon systems
 T $SYSRRC.KL = CLIP(SRRC1.K, SRRC2.K, SYSR.K, .5)$ DR14
 Note System Reliability Rate of Change (% /year)
 A $SRRC1.K = (1 - SYSR.K) * TABHL(TSRRC1, SRSL.K / TKPRO.K, 0, 1, .2)$ DA56
 T $TSRRC1 = -.2, -.05, 0, .01, .05, .1$ DT29
 Note System Reliability Rate of Change when $SYSR > .5$
 A $SRRC2.K = (SYSR.K) * TABHL(TSRRC2, SRSL.K / TKPRO.K, 0, 1, .2)$ DA57
 T $TSRRC2 = -.1, -.01, 0, .03, .1, .2$ DT30
 Note System Reliability Rate of Change when $SYSR < .5$

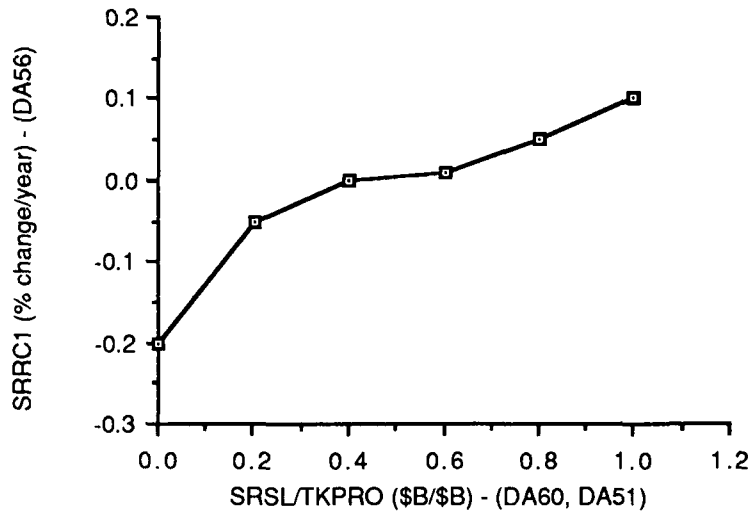

Figure 84. Structure for Determining System Reliability Rate of Change (SYSR > .5)

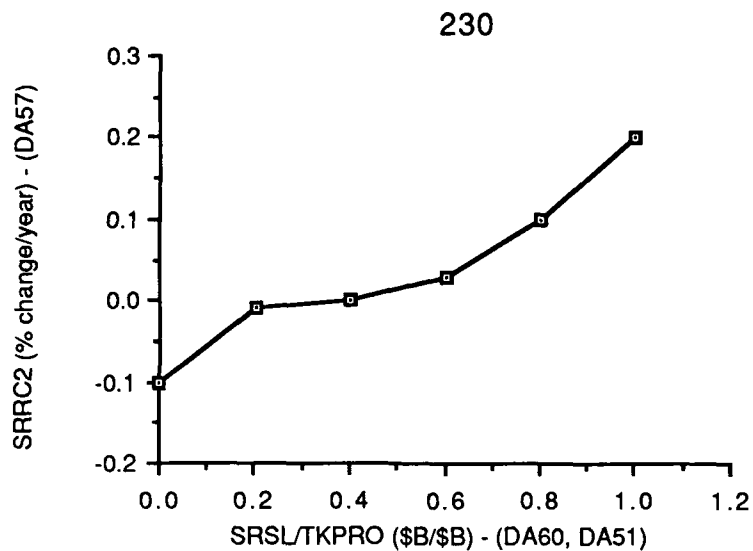

Figure 85. Structure for Determining System Reliability Rate of Change (SYSR<.5)

The desired level of technology produced (DTP) is determined by an assessment of the Soviet weapon technology. The relationship between desired technology produced and the perceived weapon technology ratio is shown in Figure 86. As the perceived level of Soviet weapon technology increases the reaction of United States decision makers is to increase the rate of R&D spending and the level of weapon technology produced. Of course the production of any weapon technology depends upon its availability and so the reaction to perceived advances in technology by the Soviets is an increase in the desired technology which will result in increases in actual technology if there is a gap between desired and available levels of technology.

A $DTP.K = TABHL(TDTP, WPNTK.K / (USIAC.K * SWTK.K), 0, 5, 1)$

DA58

T $TDTP = 15, 10, 8, 7, 6.5, 6.3$

DT31

Note Desired Technology Produced (\$ billion/year).

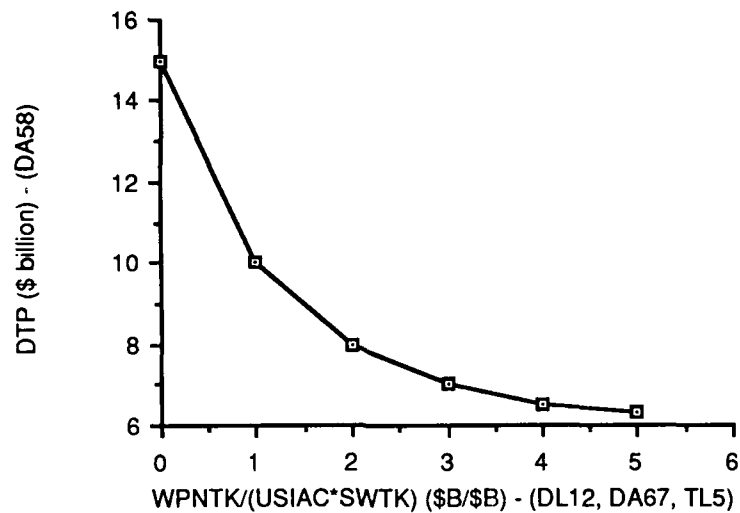

Figure 86. Structure for Perceived Weapon Technology Ratio Effect on Desired Technology Produced

The research and development expenditures were divided into two categories: weapon lethality and system reliability spending. The reliability share of the expenditures is dependent upon what is spent on lethality. The lethality share is impacted by two factors which trade off force maintainability for weapon technology overall. The determination of the lethality spending share (SLSS) is shown in Figure 87. The relationship indicates that a minimum of 50% and a maximum of 78% of the R&D expenditures will be spent on weapon lethality depending on the relative impacts of force maintainability and relative weapon technology. This range of values results in model behavior which correspond to the system reliability figures reported in the Comptroller of the Air Force report (1986).

A SYRSS.K=1-WLSS.K DA59
 Note System Reliability Spending Share (%) of R&D spending level.
 A SRSL.K=SYRSS.K*RDSL.K DA60
 Note System Reliability Spending Level (\$ billion/year).
 A WLSS.K=TABHL(TWLSS,FME.K*WTCE.K,0,100,20) DA61
 T TWLSS=.5,.6,.67,.72,.76,.78 DT32
 Note System Lethality Spending Share (%) of annual R&D expenditures.

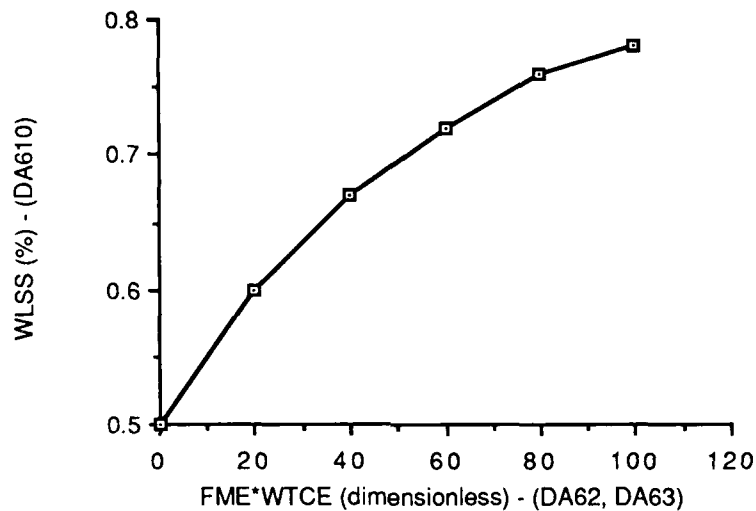

Figure 87. Structure for Force Maintainability and Weapon Technology Effect on Lethality Spending Share

The impact of force maintainability on lethality spending is determined by the difference between force maintainability and the desired level of this variable. If the desired force maintainability level, which is a function of the global tension level, is greater than the current force maintainability level the result is increased spending for system reliability. The relationship is shown in Figure 88.

A FME.K=TABHL(TFME,FM.K-DFM.K,-.5,.5,.2) DA62
 T TFME=0,.1,.3,.7,.9,1 DT33
 Note Force Maintainability Effect on lethality spending share.

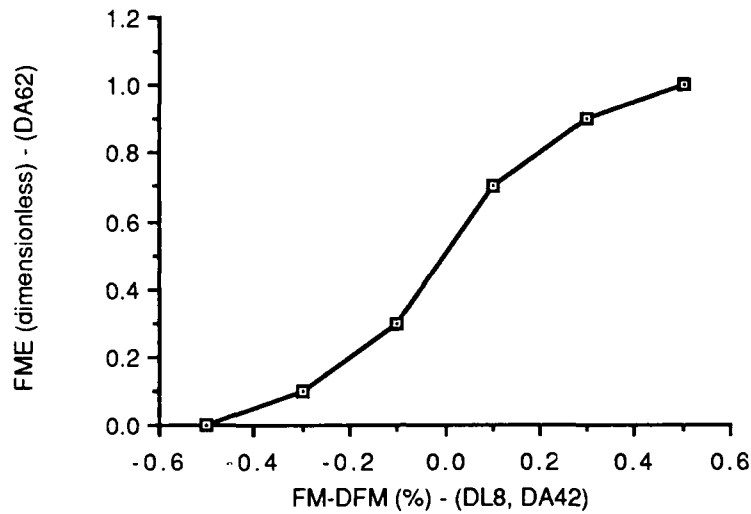

Figure 88. Structure for Maintainability Differential Effect on Lethality Spending

The impact of the weapon technology comparison on lethality spending is shown in Figure 90. The table function shows that in periods of United States dominance in weapon technology that relatively more is spent on reliability than otherwise. This relationship indicates that when both lethality and reliability levels are low that lethality spending will be the higher priority. The system lethality spending share is determined by multiplying the lethality spending share (SLSS) by the R&D spending level. The parameters chosen for these two table functions result in spending levels which closely resembles that derived from actual spending data (Comptroller of the Air Force 1986).

A WTCE.K=TABHL(TWTCE,WPNTK.K/(USIAC.K*SWTK.K),0,5,1)

DA63

T TWTCE=100,96,90,82,72,60

DT34

Note Weapon Technology Comparison Effect on system lethality spending share.

A WLSL.K=WLSS.K*RDSL.K

Note Weapon Lethality Spending Level (\$ billion).

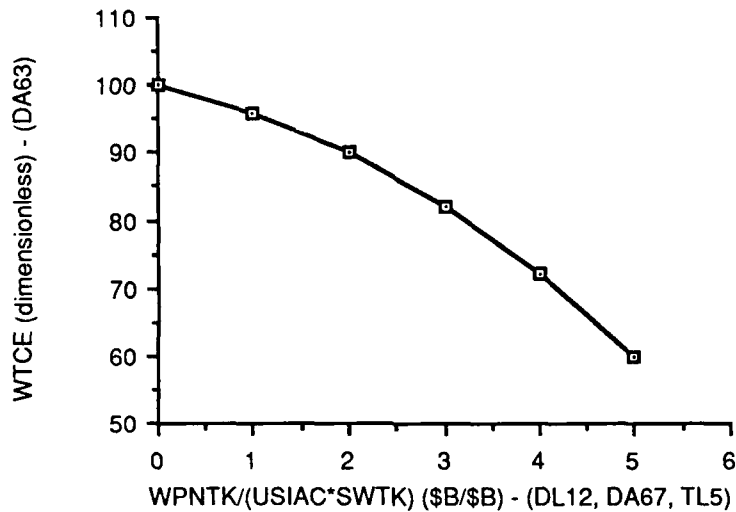

Figure 89. Structure for Perceived Weapon Technology Ratio Effect on Lethality Spending

Intelligence Resolution Structure

The final component of military capability is intelligence resolution. Intelligence resolution is measured in billions of dollars and reflects the combination of intelligence gathering and counter-intelligence capabilities. Not very much published data is available for either Soviet or American intelligence expenditures. The model reflects a fairly balanced structure. The structure for the intelligence resolution subsector is shown in Figure 90.

The level of intelligence resolution is increased with annual expenditures and is depleted over a number of years. The rate of depletion is dependent upon the relative level of United States and Soviet intelligence resolution. This reflects the capacity for each country to exploit their counter-intelligence capabilities. The level of annual intelligence expenditure is determined by the annual defense expenditures, the relative efficiency of United States

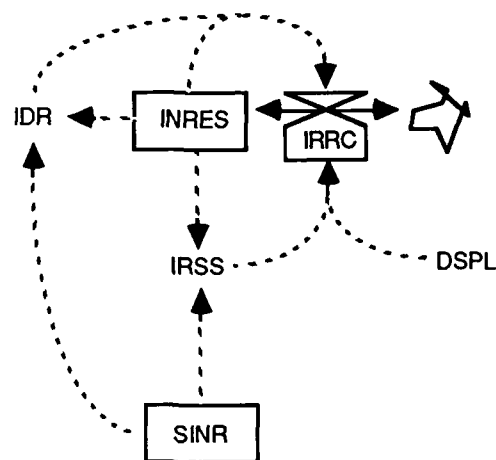

Figure 90. Defense Sector Modified Flow Diagram: Intelligence Resolution Structure

Table 6. -- Figure 90 Key

VARIABLE	NAME	MEASURE
DSPL	Defense Spending Level	\$ billion/year
IDR	Intelligence Depletion Rate	years
INRES	Intelligence Resolution	\$ billion
IRRC	Intelligence Resolution Rate of Change	\$ billion/year
IRSS	Intelligence Resolution Spending Share	%
SINR	Soviet Intelligence Resolution	\$ billion

intelligence spending, and the intelligence resolution share of those expenditures (IRSS). The United States intelligence expenditures are less efficient than Soviet intelligence expenditures because of the relative ease with which the Soviets are able to gather information in the United States. Because of this, United States expenditures are multiplied by a 60% efficiency factor. The size of the intelligence share is determined by an assessment of the relative Soviet and United States intelligence resolutions. This relationship is shown in Figure 91. Intelligence expenditures fluctuate between 8.5% and 11.5% of the defense expenditures. An initial level of intelligence resolution of nine billion dollars was based on initial annual effective expenditures of three billion dollars and a three year depreciation rate.

L	$INRES.K = INRES.J + (DT * IRRC.JK)$	DL15
N	$INRES = 9$	
Note	Intelligence Resolution (\$ billion).	
R	$IRRC.KL = (ISE * IRSS.K * DSPL.K) - (INRES.K / IDR.K)$	DR15
Note	Intelligence Resolution Rate of Change (\$ billion/year).	
C	$ISE = .6$	
Note	Intelligence Spending Efficiency (%).	
A	$IRSS.K = TABHL(TISS, INRES.K / SINR.K, 0, 2, .5)$	DA65
T	$TISS = .115, .105, .1, .095, .085$	DT35
Note	Intelligence Resolution Spending Share (%) of annual defense expenditures.	

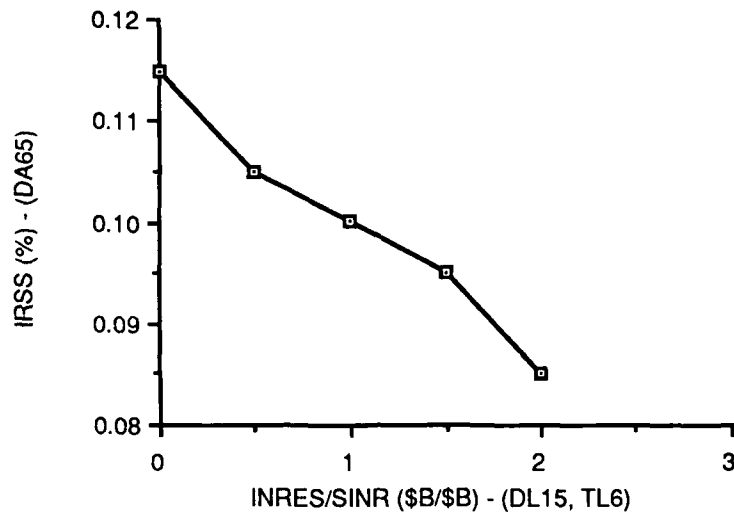

Figure 91. Structure for Perceived Intelligence Ratio Effect on Intelligence Spending

The relationship between intelligence resolution depletion rate and the actual intelligence resolution ratio is shown in Figure 92. When the United States is in a very poor relative position in terms of intelligence, the intelligence resolution declines at a rate of 50% per year (two year depreciation rate). When in a very strong relative position, the intelligence resolution takes twice as long to deplete.

A IDR.K=TABHL(TIDR,INRES.K/SINR.K,0,2,.5)

T TIDR=2,2.7,3,3.3,4

Note Intelligence resolution Depreciation Rate (years).

DA66

DT36

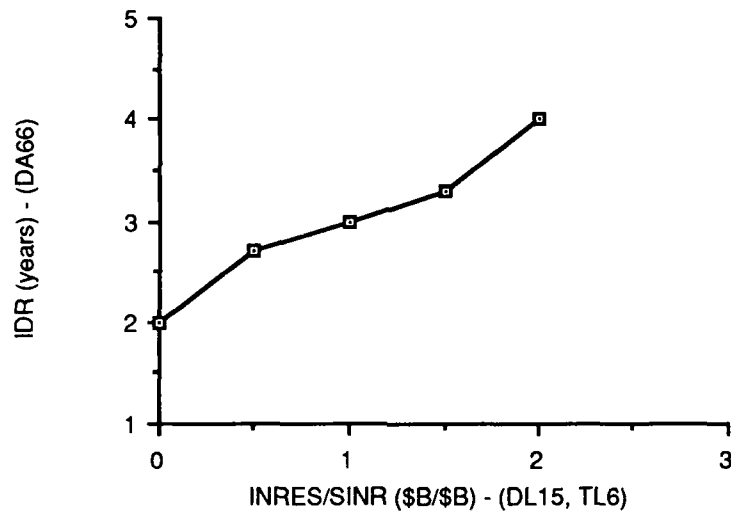

Figure 92. Structure for Actual Intelligence Ratio Effect on Intelligence Depletion Rate

Just as with Soviet intelligence accuracy in the threat sector, the United States intelligence accuracy multiplier (USIAC) is modeled as a function of the ratio of the intelligence resolution. When the two superpower's intelligence resolution is equal the result is that both tend to overestimate the other's aggregate capability by ten percent. The overestimation is due to the fact that intelligence estimates are less accurate the further into the future assessments are made and the propensity of the intelligence communities to use conservative estimates (Dyer 1985). This relationship is shown in Figure 93. In situations where the Soviets have an advantage in their intelligence capability the the United States overestimates the Soviet capabilities to an even greater degree.

A $USIAC.K=1+USBIAS*AMP.K$

DA67

Note US Intelligence Accuracy

C $USBIAS=.1$

Note US Intelligence Bias (% overestimation).

A $AMP.K=TABHL(TIAC,INRES.K/SINR.K,0,2,.5)$

DA68

T $TIAC=1,.2,.1,.05,.03$

DT37

Note Amplifier of US intelligence Accuracy.

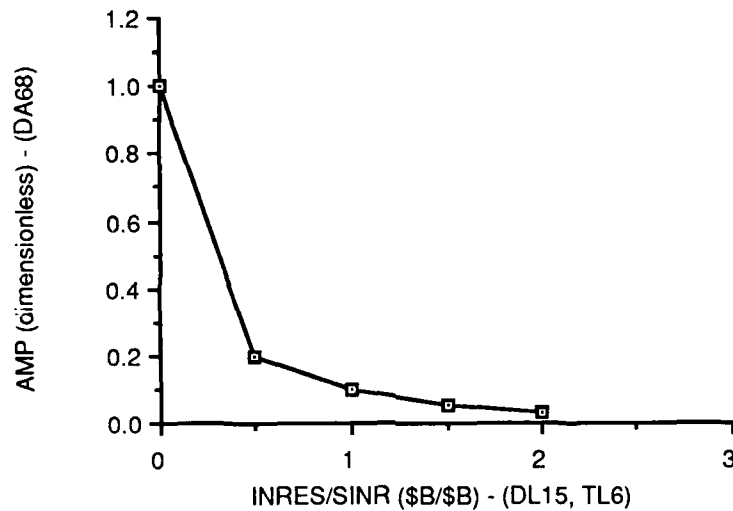

Figure 93. Structure for Intelligence Resolution Ratio Effect on Intelligence Accuracy Amplifier

The defense sector model has detailed the decision making structure which is concerned with allocating defense expenditures among the competing capability components. The weapon inventory subsector detailed the decision making structure which is concerned with the production of weapon systems. The decisions made in the defense sector determine to a great degree how efficiently the defense expenditures are used. However it is the structure of the defense industry that determines how efficiently the defense funds spent on the acquisition of weapon systems are used. The structure of the defense industry

model is described in the next section.

Industry Sector

The primary role of the industry sector is the determination of the unit cost of the weapons which are procured. Weapon system unit cost is affected indirectly by many of the policies and structures reflected in the other three sector models. Weapon system unit cost is a function of production costs and industry profit margins within the industry sector. Production costs are influenced by industry capacity utilization, industry production technology, industry competitiveness, as well as weapon design specifications, production rate, and other variables which are determined outside of the industry sector model. Industry profits are impacted by the number of firms competing within a given industry, the production technology level, and the capacity utilization. The industry sector model will detail the relationships of these variables, the industry sector modified flow diagram is presented in Figure 94.

The defense industry is actually the aggregation of many individual industries. In this model the impact of the individual industry structures on weapon unit cost has been aggregated and is patterned somewhat after the defense aircraft industry. The defense aerospace industry is characterized by low levels of capital investment relative to commercial goods producers, excess capacity at the prime contractor level, and production of state of the art weapon systems (Gansler 1980).

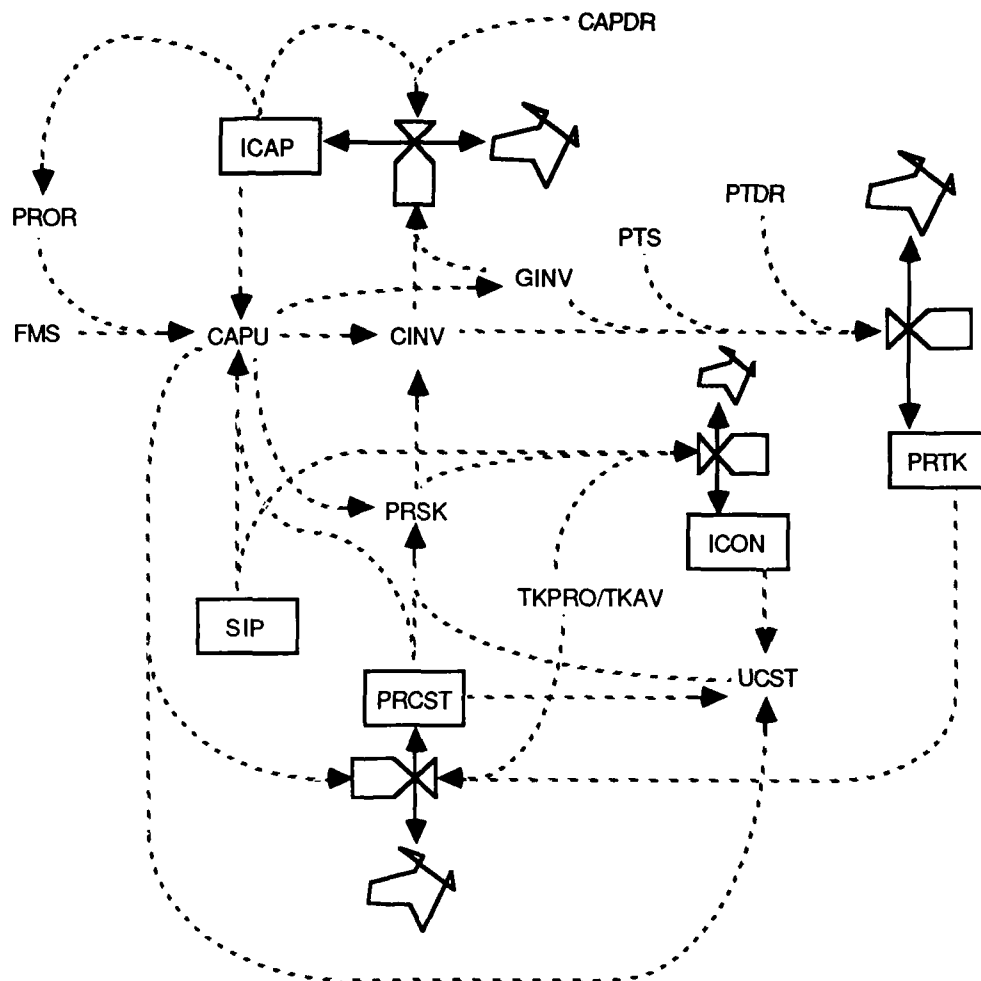

Figure 94. Industry Sector Modified Flow Diagram

Table 7. -- Figure 94 Key

VARIABLE	NAME	MEASURE
CAPDR	Capital Depreciation Rate	years
CAPU	Capital Utilization	%
CINV	Industry Capital Investment	\$ billion/year
FMS	Foreign Military Sales	\$ billion/year
GINV	Government Investment	\$ billion/year
ICAP	Industry Capital Stock	\$ billion
ICON	Industry Concentration	production/year firms/industry
PRCST	Production Cost	\$ billion/unit/system
PROR	Production Rate	units/system/year
PRSK	Perceived Risk	risk units
PRTK	Production Technology	\$ billion
PTDR	Production Technology Depreciation Rate	years
PTS	Production Technology Share	%
SIP	Systems in Production	systems
TKAV	Technology Available	\$ billion
TKPRO	Technology Produced	\$ billion
UCST	Unit Cost	\$ billion/unit/system

The capacity of the industry is measured in billions of dollars of annual production capacity. An initial level of \$24 billion was based on initial weapon production expenditures of approximately \$12 billion and a capacity utilization of nearly 50% (Gansler 1980, 174). Industry capacity (ICAP) is increased by industry and government capital investment in plants and equipment and decreases over time due to depreciation. Annual capital investment levels for the industry is determined by a comparison of the current capacity utilization and the perceived risk. The relationship between industry investment and these factors is shown in Figure 95.

L	$ICAP.K = ICAP.J + (DT * ICAPRC.JK)$	IL1
N	$ICAP = 24$	
Note	Industry Capacity (\$ billion annual production capacity).	
R	$ICAPRC.KL = CINV.K + GINV.K - (ICAP.K / CAPDR)$	IR1
Note	Industry Capital Rate of Change (\$ billion/year).	
C	$CAPDR = 30$	
Note	Capital Depreciation Rate (years).	
A	$CINV.KL = TABHL(TCINV, CAPU.K / PRSK.K, 0, 1, .2) * ICAP.J$	IA1
T	$TCINV = 0, .02, .03, .035, .038, .04$	IT1
Note	Capital Investment (\$ billion/year)	

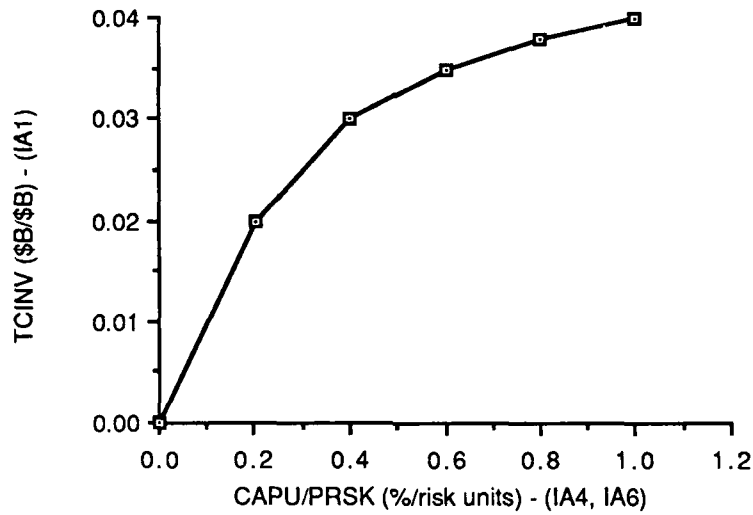

Figure 95. Structure for Industry Capital Investment

Government capital investment in the defense industry is justified by the desire to maintain an excess defense production capability which could be a valuable asset in time of war (Gansler 1980). Government investment is modeled as a function of capacity utilization; as capacity utilization approaches 100% higher levels of investment result. Likewise as capacity utilization goes toward zero additional capital investment is not required. The relationship between government investment and capacity utilization is shown in Figure 96.

A $G_{INV.K} = WASL.K * GIP.K$ IA2

Note Government Investment (\$ billion annual production capacity).

L $GIP.K = GIP.J + (DT * GIPRC.JK)$ IL2

Note Government Investment Percentage (%) of weapon acquisition spending

Note level.

R $GIPRC.KL = TABHL(TGIP, CAPU.K, 0, 1, .2) * GIP.K$ IR2

T $TGIP = 0, .007, .016, .027, .04, .06$ IT2

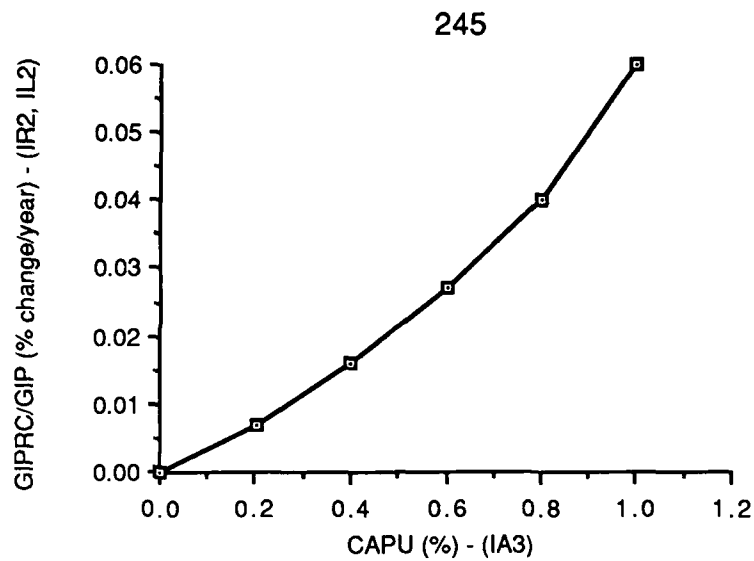

Figure 96. Structure for Government Capital Investment

Capacity utilization (CAPU) is determined by adding the level of foreign military sales to the production cost for all units produced in a given year and dividing by the industry capacity. Foreign military sales (FMS) is measured in billions of dollars of production capacity used, and is treated as an exogenous variable, which may be used to reflect United States policy concerning arms transfers. The perceived risk of the industry is an economic notion that is an attempt to explain why defense firms are slow to invest in production capital. In reality it is a function of a great many factors including budget instability, program instability, and cost reimbursement policies. The notion of risk was modeled as a function of the difference between the unit price of a weapon system and the production cost and the level of capacity utilization. This implies that if the profit level is high enough the industry will perceive less risk, that is the perceived risk is reduced. This relationship is shown in Figure 97.

A	$CAPU.K = (FMS.K + (PROR.K * SIP.K * PRCST.K)) / ICAP.K$	IA3
Note	Capacity Utilized (%)	
A	$FMS.K = 1$	IA4
Note	Foreign Military Sales (\$ billion annual production)	
A	$PRSK. = TABHL(TPRSK, ((UCST.K - PRCST.K) / UCST.K) * CAPU.K, 0, .2, .05)$	IA5
T	$TPRSK = 10, 7, 3, 1, 0$	IT3
Note	Industry Perceived Risk (risk index, 0=No risk, 10=high risk)	

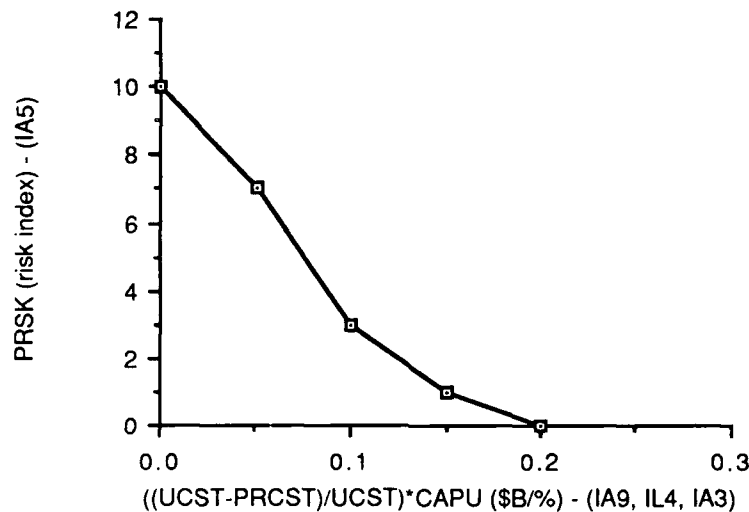

Figure 97. Structure for Perceived Risk

Industry concentration (ICON), which reflects the number of firms competing in a market, was used as a surrogate measure for industry competitiveness. It is assumed that as the concentration goes up, that is firms drop out of an industry, that the industry gets less competitive and that as the concentration goes down that the industry becomes more price competitive. Concentration of the industry depends to a great extent on the ease with which firms can enter or leave the industry in question. Many of the defense industries are characterized by severe barriers to entry (Gansler 1980). This is reflected in

the rate of change of concentration which tends to increase more quickly than it recedes. Industry concentration is modeled as a function of perceived risk, profitability, the number of systems in production, and the technology level of the weapons which are procured. The relationship between perceived risk and industry concentration change is shown in Figure 98. As profitability goes up smaller firms are encouraged to compete and some new firms may enter the industry. As profits go down firms may tend to shy away from defense work and concentrate on commercial production. An initial level of industry concentration of five firms was based on Gansler's (1980, 42) survey of 23 military markets in which 12 markets had higher than 90% four-firm concentration ratios and the lowest was 50%.

L	ICON.K=ICON.J+(DT*ICONRC.JK)	IL3
N	ICON=5	
	Note Industry Concentration (four firm concentration ratio).	
R	ICONRC.KL=(TPEC.K+PREC.K+SIPEC.K)*ICON.K	IR3
	Note Industry Concentration Rate of Change (%/year).	
A	PREC.K = TABLE (TPREC, PRSK.K,0,10,2)	IA6
T	TPREC=.05,.02,.007,0,-.01,-.05	IT4
	Note Perceived Risk Effect on Concentration (% change/year).	

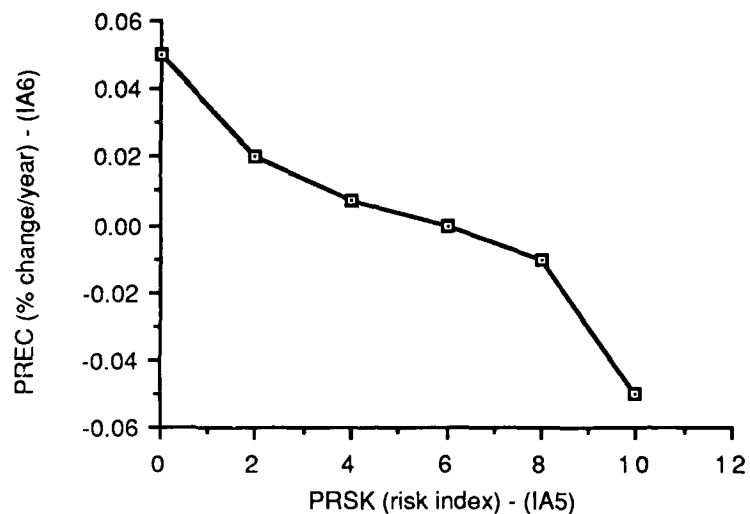

Figure 98. Structure for Perceived Risk Effect on Industry Concentration

One of the largest barriers to entry in the defense industry is the high level of technological sophistication which is required of the contractors. As the technology level of the weapons which are produced increases so does this barrier to entry. The relationship between technology produced and changes in industry concentration are shown in Figure 99.

A TPEC.K=TABHL (TTPEC, TKPRO.K,0,10,2)

IA7

T TTPEC=.02,.005,0,-.002,-.005,-.02

IT5

Note

Technology Produced Effect on Concentration (% change).

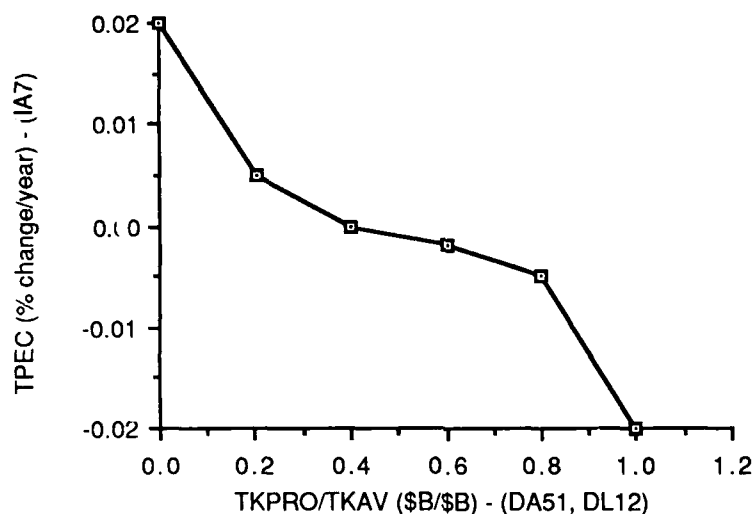

Figure 99. Structure for Technology Produced Effect on Industry Concentration

The number of systems in production also has an impact upon the number of firms which remain in an industry. As the number of weapon systems in production declines the number of firms that can land contracts also declines. In cases where firms team up to bid on large weapon programs the result is the same as if there were fewer firms bidding independently, that is competition is reduced. The relationship between systems in production and industry concentration is shown in Figure 100.

A SIPEC.K=TABHL(TSIP,SIP.K/ICON.K,0,4,1)

T TSIP=-.3,-.1,-.03,0,.01

Note Systems in Production Effect on Concentration (% change).

IA8

IT6

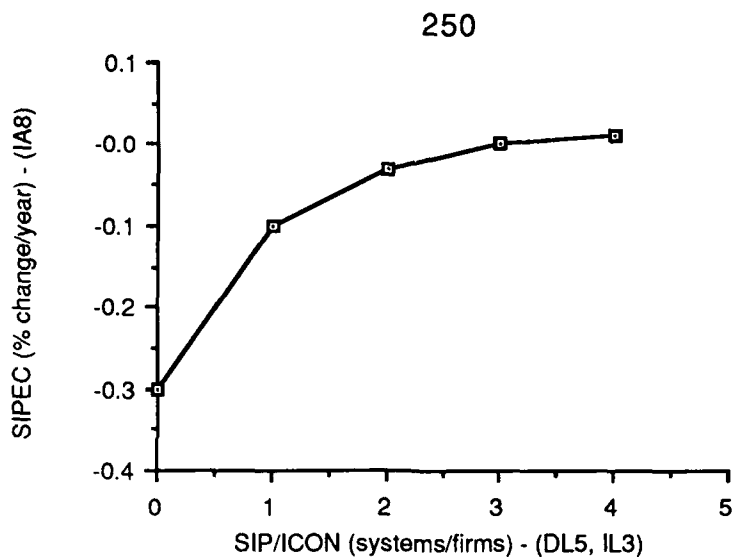

Figure 100. Structure for Systems in Production Impact on Industry Concentration

The unit cost of a weapon system is determined by production costs and the profit level that the firms are able to negotiate. The ability of a firm to negotiate is determined by the structure of the industry. Therefore the concentration of the industry which reflects competition within an industry, and the industry's capacity utilization is used to modify the profit as a percentage of production cost. If capacity utilization is high then there is not as much incentive to bid competitively as when capacity utilization is low. The relationship between concentration, capacity utilization and profit markup is shown in Figure 101. The initial level of weapon unit production cost (PRCST) was chosen in conjunction with the units per system variable in the defense sector. Since the notion of a weapon system in this model represents everything from tanks to aircraft carriers the numbers must be in a broad range but it is the relative

change in these variables' values which is important rather than the specific values.

A $UCST.K = PRCST.K * ICEUC.K$

IA9

Note Unit Cost (\$ billion/ unit produced).

A $ICEUC.K = TABHL(TICE, ICON.K / CAPU.K, 1, 10, 3)$

IA10

T $TICE = 1.2, 1.15, 1.11, 1.08, 1.07$

IT7

Note Industry Concentration Effect on Unit Cost (dimensionless).

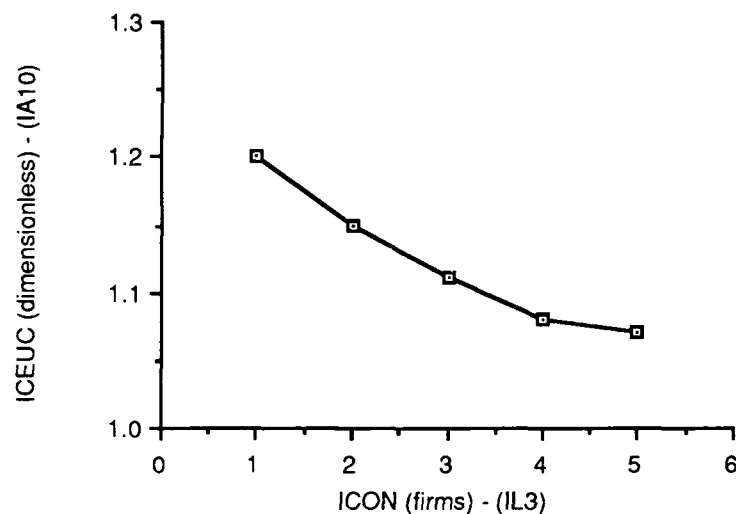

Figure 101. Structure for Industry Concentration and Capacity Utilization Effect on Profit Markup

The cost of producing a weapon system unit is dependent upon four factors: the technology associated with the design specifications, the production technology, the state of capacity utilization, and the production rate. High technology weapons tend to involve more exotic materials and production processes and thus cost more. The use of highly advanced means of production including robotics has been shown to greatly reduce production costs in many industries. How well the production capacity is matched with the

production rate also impacts production cost. An initial production cost level of nine million dollars per unit was chosen based on an initial unit cost figure of ten million dollars and a ten percent return on sales (Gansler 1980,140).

The relationship between technology produced and production cost is shown in Figure 102. The higher proportion of the technology which is available for production that is produced the higher is the cost of production. Striving for the last marginal increases in weapon performance is relatively expensive and is reflected in the sharp upward slope of the curve when greater than 60% of the available technology is produced.

L	PRCST.K=PRCST.J+(DT*PCRC.JK)	IL4
N	PRCST=.009	
Note	Production Cost per unit (\$ billion/ unit).	
R	PCRC.KL=((TPEPC.K+PTEPC.K+PREPC.K)*CUEPC.K)*PRCST.K	IR4
Note	Production Cost Rate of Change (\$ billion/unit/year).	
A	TPEPC.K=TABHL(TTPEPC,TKPRO.K/TKAV.K,0,1,.2)	IA11
T	TTPEPC=-.05,-.02,-.005,0,.03,.1	IT8
Note	Technology Produced Effect on Production Cost (% change/year).	

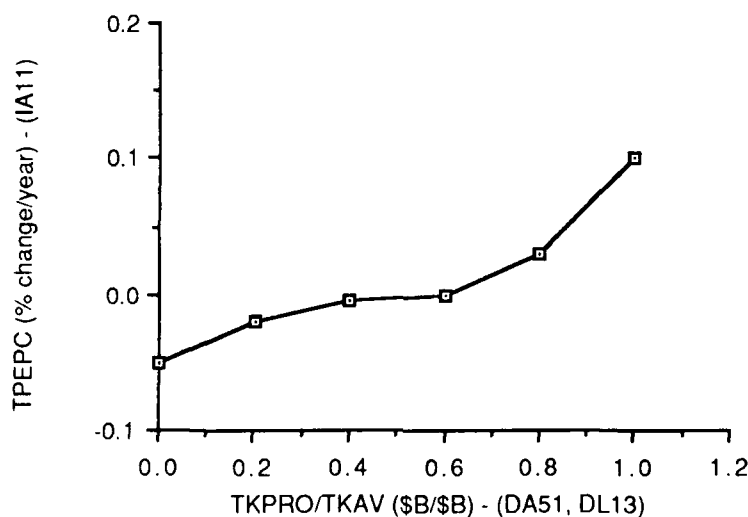

Figure 102. Structure for Technology Produced Effect on Production Cost

The relationship between production technology and production cost is shown in Figure 103. Much like the impact of the technology produced large cost increases are possible when too little technology is brought to bear in producing high technology weapons. However significant cost reductions are also possible if large investments in production technology are made (Gansler 1980).

A PTEPC.K=TABHL(TPTEPC,PRTK.K,0,2,.4)

T TPTEPC=.06,.03,.01,0,-.01,-.05

Note Production Technology Effect on Production Cost (% change/year).

IA12

IT9

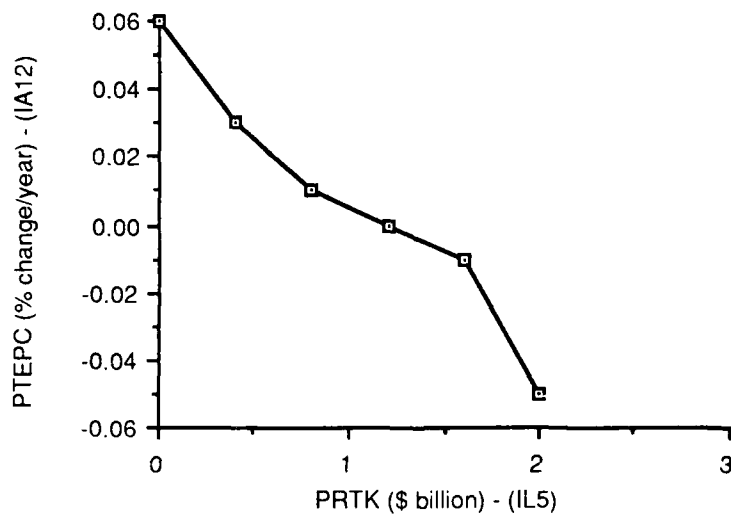

Figure 103. Structure for Production Technology Effect of Production Cost

The impact of production rate effect on production cost is such that when the production rate is lowered that cost per unit goes up as overhead reductions lag production rate reductions. The difference between the production rate and the delayed production rate indicates the annual change in production rate.

The relationship between industry capacity utilized and production cost is shown in Figure 104. In instances where too much capacity exists the excess overhead is prorated over fewer units, and in cases where too little capacity exists production often gets bogged down and bottlenecks develop slowing production and raising costs. Therefore production costs tend to increase when capacity utilization strays too far from "optimal" which is thought to be near 90% utilization (Gansler 1980).

A $PREPC.K = -.1 * (PROR.K - DLINF3(PROR.K, 1)) / PROR.K$ IA13
 Note Production Rate Effect on Production Cost (% change/year).
 A $CUEPC.K = TABHL(TCUEPC, CAPU.K, 0, 1, .2)$ IA14
 T $TCUEPC = 3, 1.5, 1.1, 1, .9, 1.1$ IT10
 Note Capacity Utilization Effect on Production Cost (dimensionless).

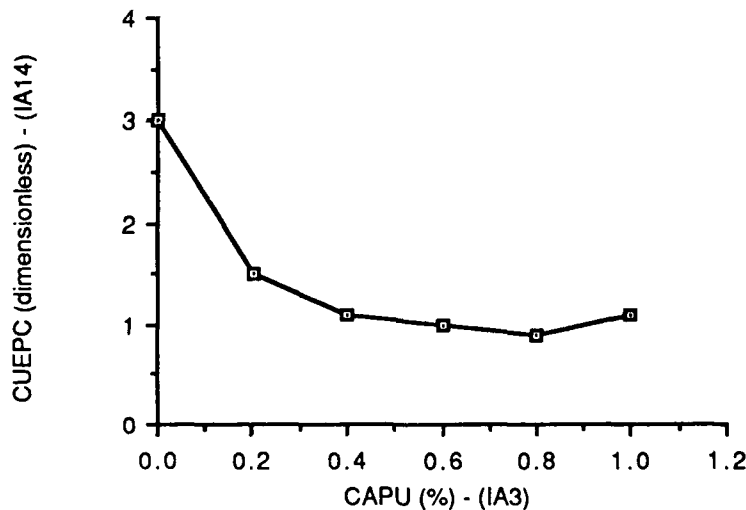

Figure 104. Structure for Capacity Utilized Effect on Production Cost

Production technology which is measured in billions of dollars is a variable which denotes the amount of capital investment in high technology means of

production. Because the emphasis is on high technology production methods this variable is depreciated more quickly than is normal capital equipment. The concept of production technology (PRTK) is modeled so that a certain share of industry investment is made in high technology production methods while the rest is made in more general purpose production equipment. The initial level of production technology is based on \$1.2 billion of capital investment per year by the defense industry and the government, a ten percent share going to high technology production capital equipment and a ten year depreciation rate for that capital equipment.

L	$PRTK.K = PRTK.J + (DT * PTRC.JK)$	IL5
N	$PRTK = 1.2$	
Note	Production Technology level (\$ billion).	
R	$PTRC.KL = (PTS * CINV.K + GINV.K) - (PRTK.K / PTDR)$	IR5
Note	Production Technology Rate of Change (\$ billion/ year).	
C	$PTDR = 10$	
Note	Production Technology Depletion Rate (years).	
C	$PTS = .1$	
Note	Production Technology Share of industry capital investment.	

Summary

The parametric model which was described in detail in this chapter integrates four individual sector models into a single integrated model. The resulting simulation model can be used to evaluate any of a number of possible policies which might be developed to deal with the management of the acquisition of weapons. The policy alternatives are not limited to policies which can be implemented within the Department of Defense. The boundaries of the

model allow for policies to be tested which are directed at the industrial, national and international level as well.

The parametric models are closely related to the conceptual models presented in Chapter 4 and much of the confidence in the parametric model is a result of the validation process which the conceptual models were exposed to. Further validation of the parametric model was accomplished in accordance with the procedures recommended by Forrester and Senge (1980) which were described in Chapter 3. The validation process was an integral part of the modeling process and was performed simultaneously rather than as a separate procedure. The results of the Forrester and Senge validation procedure are described in the next chapter and are reflected in the model presented in this chapter.

CHAPTER 6

MODEL VALIDATION AND EXPERIMENTATION

Introduction

The purpose of this chapter is to describe the results of the validation procedure, presented in Chapter 3, and to demonstrate how the simulation model presented in Chapter 5 can be used to perform policy analyses. Reporting the results of the validation process is important in order to transfer some of the confidence in the model which was accumulated during the modeling and validation process to the reader. According to Forrester and Senge: "validation is the process of establishing confidence in the soundness and usefulness of a model" (Forrester and Senge 1980, 210). The validation process is an ongoing one which can never truly be completed. The results of the validation process are reported in subsequent sections following the procedure that was laid out by Senge and Forrester, and discussed in Chapter 3

Not only is the validation process impossible to complete, but the notion of a valid model, that is one that inspires confidence, is a relative one. The notion of validity is relative to the purposes for which the model is constructed. To some, a model that facilitates insight into the structure of the real system or makes accurate predictions might be considered useful, while to others, a

useful model must explain causal relationships and "provide a basis for designing policies that can improve behavior in the future" (Forrester and Senge 1980, 211). In light of this concept of model validity, the validation tests which were performed with the parametric model developed during this research are presented and at each point a level of confidence about each one established. The measures low, medium and high were used to guide overall assessment of the model's value. At the conclusion of the chapter, a policy analysis experiment is demonstrated using the model.

Tests of Model Structure

Forrester and Senge (1980) outlined five separate tests of model structure. The first such test is the "structure-verification test" which was aimed at verifying that the model structure does not "contradict knowledge about the structure of the real system" (Forrester and Senge 1980, 212). This test was conducted in a two step process. The first step was the validation of the conceptual model presented in Chapter 4. This was important because the conceptual models provided the theoretical framework upon which the simulation model rests. The validation of the conceptual model was conducted using a combination of three methods. The model had to satisfy the modeler that it was valid based on experience with and knowledge of the system's structure. The model was also subjected to a critique based on a review of the weapon acquisition literature. Finally, the conceptual model was subjected to

criticisms from a wide variety of experts on the policies of weapon acquisition. The critique of the experts is discussed in detail in Appendix A.

The second step in the verification of structure test was to compare the emerging parametric model with the validated conceptual model. These comparisons were important because the conceptual models had been reviewed by system experts while the modified flow diagrams and the parametric code were not subjected to such a rigorous review. During the parametric modeling process additional detailed structures tended to "creep into" the model and often they conflicted with the conceptual model. The result was an overly complex model that at times was conceptually invalid. By comparing the conceptual and parametric models at regular intervals, the parametric model tended to remain more parsimonious and more accurate conceptually. This process also helped to shape the boundaries of the model in that only those concepts were included which supported the original goals of the conceptual model.

The purpose of this test was only to determine whether or not the important model structures had real system structures to which they corresponded (Forrester and Senge 1980). Given the reaction of the experts and the results of the literature review, a high level of confidence in the structure of the model was established.

The second test of model structure is the "parameter-verification test" which entailed "comparing model parameters to knowledge of the real system

to determine if parameters correspond conceptually and numerically to real life" (Forrester and Senge 1980, 213). The simulation model includes nineteen parameters or constants. This is a relatively small number for a model of this size, and is due in part to the fact that this model is meant to evaluate the long-term impacts of policy options, so in the long-term, fewer of the modeled concepts could be treated as constants. Each of the parameters correspond conceptually to the reference system although data for some of them do not exist or were impossible to obtain. Ten of the parameter values were chosen based on experimentation and in concert with other parameter values based on their combined impact on model behavior. The other nine parameter values were estimated using a combination of experimentation and available empirical data. Two of these parameters (PCC, TSI) were taken directly from another system dynamics study (Low 1980). The parameters, their values and the method of estimation are presented in Table 8. Because several of the parameters were chosen based on model experimentation and their impact in concert with other parameters on model behavior this test is judged to provide a medium level of confidence.

The third test of model structure is the "extreme-conditions test" which entailed tracing through all of the determinants of every rate equation in the model to determine the plausibility of the resulting rate of change when extreme conditions in preceding levels are reached. This was accomplished by testing each rate equation in the model sequentially by determining what the impact on

Table 8. -- Parameter Verification Results

Sector	Parameter	Source
Threat		
	SRSE=.4 Soviet Readiness Spending Efficiency	Experimentation
	SRDR=2 years Soviet Readiness Depreciation Rate	Experimentation
	SPE=.6 Soviet Production Efficiency	Experimentation
	STE=.6 Soviet Weapon Technology Efficiency	Experimentation
	SISE=.7 Soviet Intelligence Spending Efficiency	Experimentation
	SBIAS=.1 Soviet Intelligence Bias	Experimentation
National		
	PCC=.8 Initial Propensity to Consume	Low (1980)
	TSI=2 years Time to Smooth Income	Low (1980)
	LIGR=.04 Long-term Investment Growth Rate	Experimentation and Federal budget data
	IPER=15 years Investment Period	Experimentation and Federal budget data
Defense		
	DSP=.08 Development Starts Proportion	Experimentation and DoD budget data
	DSDR=4 years Developed Systems Depreciation Rate	Experimentation and Peck and Scherer (1962)
	DSPP=5 years Desired System Production Period	(Smith and Friedman 1980)

Table 8. -- Parameter Verification Results Continued

Sector	Parameter	Source
Defense		
	PCR=0 Production Cancellation Rate	Experimentation
	LTSE=.6 Lethality Technology Spending Efficiency	Experimentation
	ISE=.6 Intelligence (U.S.) Spending Efficiency	Experimentation
	USBIAS=.1 U.S. Intelligence Bias	Experimentation
Industry		
	CAPDR=30 years Industry Capital Depreciation Rate	Gansler (1980)
	PTDR=10 years Production Technology Depreciation Rate	Experimentation
	PTS=.2 Production Technology Share	Experimentation

the rate of change was when each of the auxiliary and level equations that determined rate of change reached their extreme values. Every combination of extreme values, both low and high, was tested. If the rate of change at the extremes was implausible, the model structure was modified. Otherwise, the structure was left intact and confidence in the model increased. This test was conducted exhaustively and thus the confidence was judged to be high.

The fourth test of model structure is the "boundary-adequacy test" which was used to determine whether or not the model level of aggregation was appropriate and whether or not the model included all of the relevant structure. This test was conducted relative to the policies discussed in Chapter 1 and the policy analysis presented at the end of this chapter. The results of the test are relative to the policy or policies which the model is used to test. In this respect, the model's boundary adequacy has not been tested very completely as it has not been exposed to a wide range of possible policy analyses. The results of the test indicated that some of the model structures included in the model presented here were not necessary to test the policies which were to guide the model's development. The model, however, was not developed to perform a specific policy analysis, and so it includes some generally applicable structures which may or may not be useful for specific policy analyses. The model's validity relative to this test was judged to be medium. Given the nature of the test and the ability of the model to handle a variety of policy alternatives, this is not a problem.

The fifth and final test of model structure is the "dimensional-consistency test." The test entailed a dimensional analysis of every one of the model's rate equations to ensure that the correct units resulted from the mathematical equations. Each of the rate equations was checked to ensure that the units on both sides of the equal sign were identical. No scaling parameters were used in the model in order to pass this test and so the confidence in the model with respect to dimensional consistency was judged to be quite high.

Tests of Model Behavior

Forrester and Senge (1980) described eight tests of model behavior which deal with evaluating model generated behavior in comparison with actual data as well as with subjective expectations of system behavior. The first such test is the "behavior-reproduction test" which entailed examining how closely model generated behavior matches the observed behavior of the real system. The behavior of the model was compared with *historical time series data*. The comparisons presented below indicate that the model was able to *reproduce fairly closely the actual system behavior*. All figures are in billions of 1960 constant year dollars, and are derived from the "Historical Tables, Budget of the U.S. Government, FY 1987."

The comparison of actual GNP figures with model GNP values, shown in Figure 105, indicates that the model exhibits cyclic growth behavior with a long term growth rate which is quite close to that of the United States economy. The

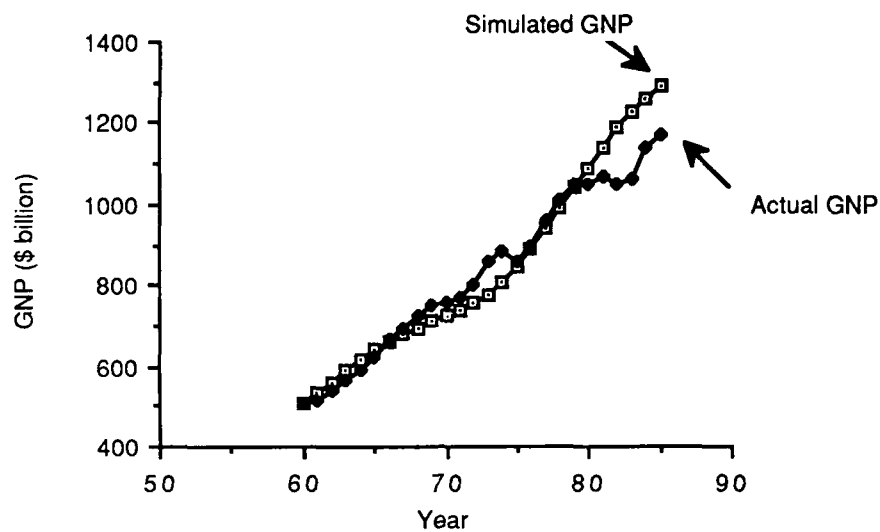

Figure 105. Actual vs Model GNP (1960-1985)

fact that the model did not generate real decreases in GNP in any period was not considered to be a problem because the impact of the recessions is not an important factor in the rest of the model. The behavior produced by the model provides the necessary structure and impact on the rest of the model.

"Social spending" was calculated by subtracting defense expenditures and net interest payments from the annual outlays of the United States government. The comparison of actual "social spending" with model output shown in Figure 106 indicates that the model was able to produce behavior which is quite similar to system behavior in terms of long term growth. While actual spending tends to be slightly more volatile than the model behavior, this is not of concern because the focus of the model is long-term rather than short-term behavior.

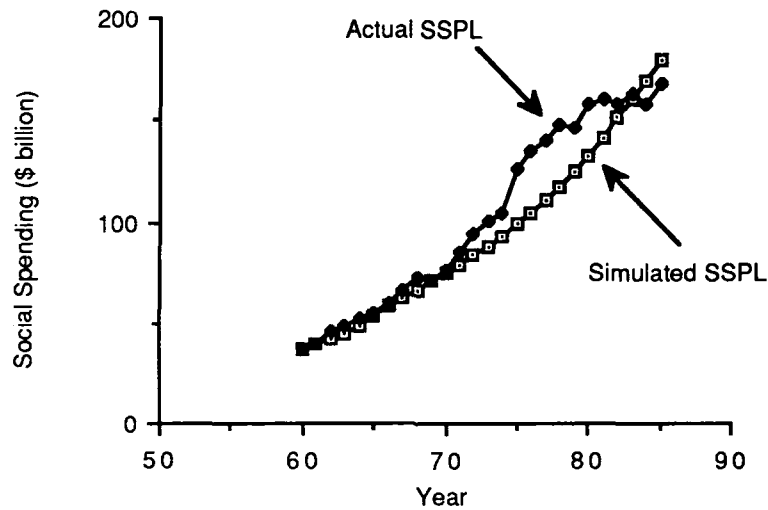

Figure 106. Actual vs Model Social Spending (1960-1985)

The comparison of actual and model defense outlays was perhaps one of the most important comparisons in that defense outlays have such a large impact on the rest of the model's behavior. The plot of actual defense outlays shown in Figure 107 indicates two rapid buildups which occurred in the period of interest and both of which required specific structures to be added to the model. The first rapid increase in defense expenditures corresponds to the Viet Nam war period. The model was modified to include a rapid increase in global tension in 1965 followed by a rapid decrease beginning in 1969. No other changes were implemented in the model and the resulting comparison of actual and model defense spending indicates that the model structure concerning the role of global tension in determining budget allocations is an effective one.

The second rapid buildup of defense spending which began in 1979 and

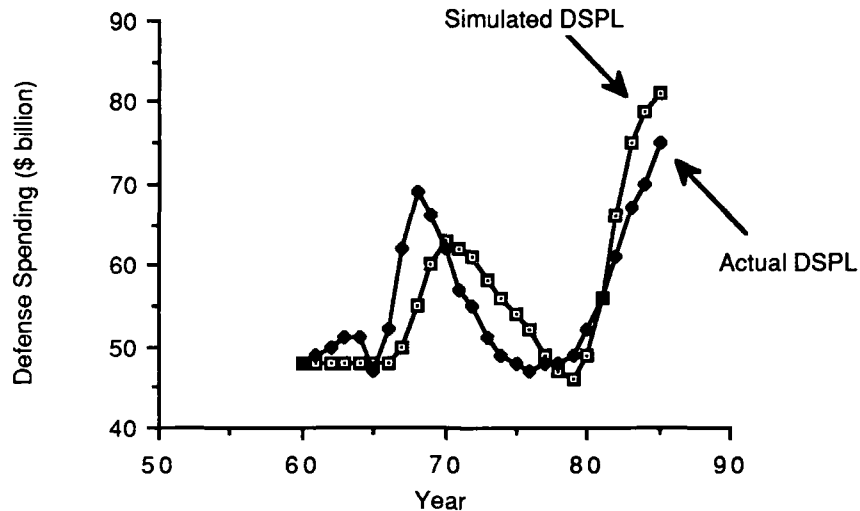

Figure 107. Actual vs Model Defense Spending Level (1960-1985)

continued through 1985 was not replicated by the basic model's structure. One possible explanation for the rapid buildup which took place during this period is that just the right political conditions existed at the time which in conjunction with a perceived "window of vulnerability", vis a vis the Soviets, led to a situation where defense spending was increased to unsustainable peacetime levels. The window of vulnerability may have been a result of the perception that the Soviets had, at some time in the mid 1970s, surpassed the United States, for the first time, in annual defense expenditures (Collins 1978). This interpretation of the early eighties defense buildup views the buildup as an anomaly which is not likely to occur periodically. The model was modified so that a rapid increase in defense expenditures begun in 1979 lasted for five years. At that point, the increase was cut off and the basic model structure

allowed to take over. The result was a curtailment of the buildup as deficit pressures mounted, this same outcome has occurred recently in the real system as defense spending has declined in real terms since the peak in 1985.

The behavior of the model in terms of Soviet defense expenditures is also a relatively important issue. Actual Soviet defense expenditures were calculated using the data available in Lee (1977) using a ruble/dollar exchange rate of 1:1.2 and adjusted for inflation using United States GNP deflators. The comparison of model and "actual" Soviet defense expenditures is shown in Figure 108. Again the model was able to replicate the long-run growth that characterizes the Soviet defense expenditures.

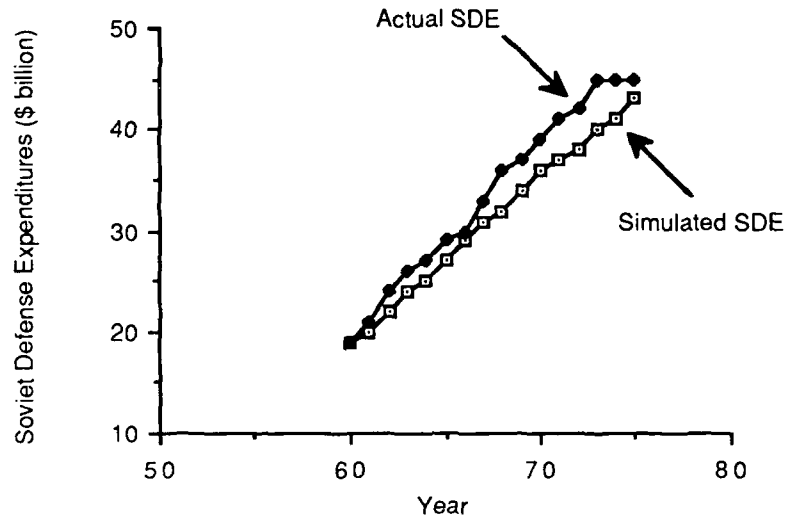

Figure 108. Actual vs Model Soviet Defense Expenditures

As noted earlier, Collins (1978) reported that at some time during the mid 1970s, Soviet and United States defense expenditures crossed for the first time

with the Soviets taking the lead. The relationship between Soviet and United States model-produced defense expenditures is shown in Figure 109 and indicates that the two are nearly equal in 1977 which corresponds to this crossing point which occurred just prior to the early eighties defense buildup.

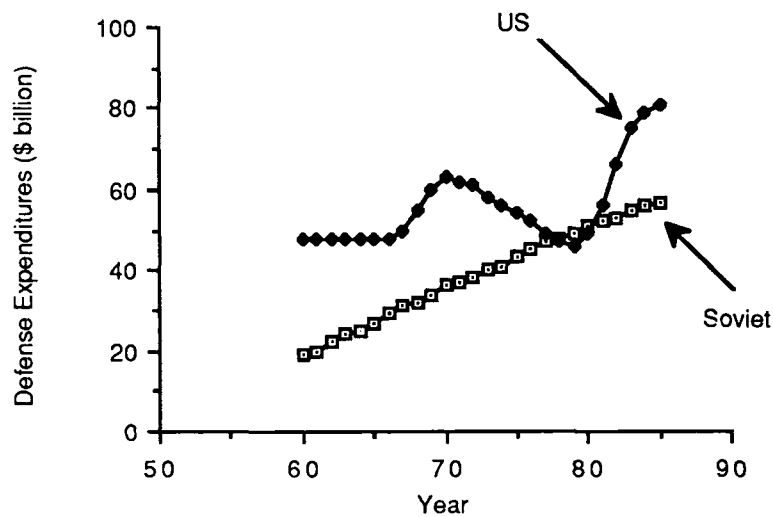

Figure 109. Comparison of Soviet and United States Model Generated Defense Expenditures

Other behaviors which showed correspondence between the real system and the model include the rise of weapon system unit costs. Gansler (1980, 16) estimated that between 1960 and 1975 unit costs for a variety of weapon systems including tanks, ships and fighter aircraft doubled in cost. This corresponds closely to model results which indicated an increase of about 240% in the same fifteen year period. The model also indicated that development and production periods were lengthening during the period 1960-1980 as was reported by Smith and Friedmann (1980). The model also

indicated a declining military force following the Viet Nam war, as well as a reduced production rate for weapon systems in production. Both of these behaviors have occurred similarly in the real system. The force size of 2.5 million men in the armed forces in 1960 had fallen to 2.15 million in 1985 against the model's 1985 level of 2.04 million.

Although many other model behaviors could be compared to actual system behaviors, confidence in the model based on this test was high as a result of its ability to reproduce the behaviors that were discussed here.

The second test of model behavior described by Forrester and Senge (1980) is the "behavior prediction test" in which model behavior is judged *subjectively against future behavior patterns of the real system*. This test was not conducted because it is beyond the scope of this research. This test could be conducted by showing *extrapolated model output, using current conditions as the initial model conditions*, to the same kind of experts that reviewed the conceptual model.

The third test is the "behavior-anomaly test" in which model behavior was compared to system behavior and any "anomalous features of model behavior which sharply conflict with behavior of the real system" was "traced to the elements of model structure responsible for the behavior" (Forrester and Senge 1980, 220). Throughout the modeling and validation effort, key model results were compared with system results. In the national sector, primary emphasis was placed on the ability of the model to reproduce system behavior

in terms of the GNP, Federal deficit, social spending and defense spending variables. In the threat sector, primary emphasis was placed on reproducing the system's behavior regarding Soviet GDP and defense expenditures. In the defense sector, force size, weapon unit cost, annual acquisition expenditures, systems in production, systems in development, development period and production period were all tracked against actual system behavior. In the industry sector, primary emphasis was placed on the model's output concerning industry capacity utilized, production cost, and industry concentration. When differences were found between model output and system behavior, model structure was reviewed and compared to the conceptual model. *Structural changes were made if necessary and otherwise, parameter values and table functions were modified to render the desired results.*

An example of this process was the point when the "Viet Nam effect" was added to the model. Prior to that time the effect of the "global tension" variable on defense spending was based on the absolute level of global tension rather than the change in global tension. This formulation did not result in a fall off in defense spending following the reduction in global tension, only the rate of change fell. Because actual expenditures did fall, it was determined that defense spending tends to increase due to changes in the level of global tension rather than react to the level of global tension. This resulted in a structural change in the model's formulation.

Another such test was conducted with the model and resulted in the

changes implemented to bring on the "early eighties buildup". The model without the additional structure showed an increase in defense expenditures beginning in 1983 instead of 1979, resulting from increased pressure due to a perception of increased aggregate Soviet military capability. The magnitude of that increase was much smaller than the actual buildup of the late 1970's and early 1980's.

Without the "early eighties buildup" effect, the model resulted in increased defense expenditures at a slow but steady pace and resulted in a more rapid escalation in weapon unit cost and a reduction in production rate, units produced per system, and the number of systems produced than did the model which included the "early eighties buildup" structure. Once the model was modified with the "early eighties buildup" structure it produced a period of slower rising weapon unit costs, increased production rates, increased units produced per weapon system and an increased number of systems produced. These beneficial effects reflect the impact that a large increase of funding can have on the efficiency of the current weapon acquisition system. This behavior was further examined in the policy experiment presented at the end of this chapter. Confidence in the model regarding the behavior anomaly test was judged to be high.

A test related to the behavior-anomaly test is the "surprise-behavior test." When surprise behavior was observed in the model output, an attempt was made to determine the causal relationships leading to the behavior, and these

causes were compared to the real system. In cases where the causes of the surprise behavior were not found in the system, model structure was modified. As an example, after a period of increased defense spending, followed by a decline to previous levels, the model indicated that fewer weapon systems are produced and fewer units of each system are produced even though cumulative spending is higher. The explanation for this behavior is that fairly quickly after an increase in defense spending, the production rate of weapon systems in production is increased and more units of each system are produced. In the longer term the number of weapon systems in production is increased, higher levels of technology are produced and the production rate again slows down. As the industry capacity utilization increases in response to the increased production rate, pressure is exerted for additional capital investment. The additional capacity is not available immediately and comes on line over the next few years. When the decrease in funding occurs, the system then reduces the production rate to accommodate lower funding levels, and this in conjunction with the additional capacity that now exists acts to make unit production costs rise much more quickly than before. This kind of surprise behavior is most often found during policy evaluations. Because this model has not been used extensively to test specific policies, confidence in the model regarding the surprise behavior test was judged low.

The fifth test of model behavior is the "extreme-policy test." The "extreme-policy test" involved altering rate equations in an extreme way and observing

the model's behavior in these conditions. One such extreme policy was tested. The policy was a one-time, 50% reduction in United States defense spending. The result was a rapid decline in military capability as the readiness component level fell rapidly. The annual increases in defense spending did not fully restore defense spending to the original level for eight years. The readiness level was not restored for 20 years as the major portion of the budget went to fund continued acquisition of weapon systems which were already in development and production. Production rates were slowed dramatically and production periods were extended. Unit cost for the weapons procured rose at four times the previous annual rate. Although it is not clear how such a drastic cut in defense expenditures would actually impact the system, the scenario reflected by the model is not impossible or even highly unlikely if a cut of that magnitude was made. Based on only one extreme policy test, the confidence in the model was judged to be low although the results of this test were good. Other extreme policies which could be tested include drastic reductions in defense budget components (e.g. acquisition funding, personnel funding, research and development funding) or a sharp reduction in the defense industry's production capacity.

The "boundary-adequacy test" of behavior is conducted to determine whether or not additional model structures are necessary in order to generate observed system behaviors. The test was conducted by running the model with and without individual model structures to determine how these structures

influenced the behavior of the model. This test was used to test alternative structures and to aid in deciding whether a structure is needed at all. In general, the test resulted in adding additional structures rather than in reducing model structures. Examples of such additions were the modifications which represent the "Viet Nam effect" and the "early eighties arms buildup". The model was unable to reproduce the observed system behavior without these additional structures. The adequacy of the boundaries of any model are relative to the policies which the model was designed to test. The model presented in Chapter 5 was developed with certain policies in mind, although some general purpose structures have been included in the model that do not necessarily support those particular policy analyses. For this reason the confidence in the model regarding the test of the model's boundary adequacy was judged to be medium.

The final test of behavior proposed by Forrester and Senge (1980) is the "behavior-sensitivity test" which focused on the sensitivity of model behavior to changes in model parameter values. Each of the nineteen parameters included in the model were varied individually between what were considered to be plausible extreme values, and the impact on the model's behavior noted. The absolute values of the Soviet and United States spending efficiency parameters were less important than their values relative to one another. If the efficiency parameters differed by more than .1, the associated military capability components tended to diverge. The value of the intelligence bias for both the

United States and the Soviets was able to vary between zero and .2 without resulting in significant changes in model behavior. At levels above .3 the global tension and defense spending levels tended to increase too rapidly. The other parameters were able to vary over wide ranges without impacting model behavior significantly. The range of values which were tested for the parameters and found not to significantly affect model behavior is shown in Table 9. The confidence in the model based on the behavior sensitivity test was judged to be high.

The tests of model behavior provide the best opportunity for passing on to model users the confidence in the model that the modeler develops during the modeling process. These tests tend to be viewed as being much more objective than some of the other tests. By concentrating on comparisons with observed system behavior, the confidence accumulated during the modeling process grew and is apparent from the previous discussion. The tests of policy implications, which are discussed in the next section, were much more subjective. The usefulness of tests of policy implications was hampered because the model was built to test the types of policies which have not yet been implemented in the system.

Tests of Policy Implications

Forrester and Senge (1980) proposed four different tests of policy implications for system dynamics models. As discussed in Chapter 3, the first of

Table 9. -- Model Behavior Sensitivity to Parameters

Parameter		Acceptable Range
SRSE=.4	(Soviet Readiness Spending Efficiency)	*
SRDR=2	(Soviet Readiness Depreciation Rate)	*
SPE=.6	(Soviet Production Efficiency)	*
STE=.6	(Soviet Weapon Technology Efficiency)	*
SISE=.7	(Soviet Intelligence Spending Efficiency)	*
SBIAS=.1	(Soviet Intelligence Bias)	*
PCC=.8	(Initial Propensity to Consume)	.6-.95
TSI=2	(Time to Smooth Income)	1-5
LIGR=.04	(Long-term Investment Growth Rate)	**
IPER=15	(Investment Period)	**
DSP=.08	(Development Starts Proportion)	.04-.12
DSDR=4	(Developed Systems Depreciation Rate)	2-10
DSPP=5	(Desired System Production Period)	2-10
PCR=0	(Production Cancellation Rate)	0-.1
LTSE=.6	(Lethality Technology Spending Efficiency)	*
ISE=.6	(Intelligence (U.S.) Spending Efficiency)	*
USBIAS=.1	(U.S. Intelligence Bias)	*
CAPDR=30	(Industry Capital Depreciation Rate)	20-40
PTDR=10	(Production Technology Depreciation Rate)	5-20
PTS=.2	(Production Technology Share)	.1-.4

Notes:

* Depends on associated Soviet/U.S. parameter value.

** Determines GNP growth rate, so these values were chosen in order to get closest match between model and system behavior.

these tests was not implemented. The second test of policy implications is the "changed-behavior-prediction test" in which policies would be changed in the model and the resulting behavioral changes evaluated subjectively. As noted in Chapter 3, these tests were not conducted because the vast majority of the policies implemented over the past 20 years have not been of the type which lend themselves to evaluation with the model presented here. This lack of a macro orientation in weapon acquisition policy analyses was one of the prime motivations for this research. The confidence in the model based on these tests is judged to be low.

The third test of policy implications suggested by Forrester and Senge (1980) is the "boundary-adequacy policy test." This test was conducted subjectively to evaluate the chosen model boundaries by determining how policy recommendations might be altered with changes in the boundaries of the model. The macro orientation of the model and the macro level policies which were used to guide the development of the model required a less complex model in general. The tendency was nearly always to model at a level of detail greater than was necessary for the policy analyses that were originally considered. Performance of this test usually resulted in deleting model structures rather than adding to the model structure. Again, the results of this test like the other boundary adequacy tests are relative to the purpose of the model. If the model was tested relative to another use, the structure would need to be modified. The confidence in the model based on this test was judged to

be medium.

The final test for building model confidence is the "" test. The emphasis of this research was placed on the development of a general purpose model which could demonstrate how a macro level policy analysis model could contribute to weapon acquisition policy debates. This emphasis did not require that policy analyses be conducted. As was stated earlier, the use of this model to perform a specific policy analysis will require that the model be modified and further validation steps be taken with the modified model. The confidence in the model based on this test, therefore, cannot be evaluated.

Summary

Eight out of ten of Forrester and Senge's (1980) "core" tests for building confidence were performed with the model. The two core tests that were not performed were tests of policy implications. Additional testing, as with any simulation model, should be conducted prior to using it, or a modification of it, for policy analysis. The process of model development and validation has only been started with this research and it is expected that if the model is used to conduct policy analysis that modifications will be made and that the validation process will be continued. This is, of course, true for any useful simulation model (Banks and Carson 1984, Shannon 1975).

A summary of the results of the validation process is presented in Table 10. Each of the confidence building tests prescribed by Forrester and Senge

(1980) is shown with a subjective rating of the level of confidence which was imparted to the model based on the completion of each of the tests. The table indicates that the lowest levels of confidence are associated with the tests which deal with policy evaluation. The confidence in the model in this area can be strengthened further as the model is used to test specific policy alternatives. Generally, confidence that the model meets its stated purposes and is thus useful has been established.

The model represents the results of the first truly systemic study of the weapon acquisition process and is a useful tool in all three of the functions described by Greenberger, Crenson and Crissey (1976). The model can be used to conduct policy experimentation such as that discussed in the next section. The model is useful as a means of developing a clearer understanding of the key feedback structures within the system which create the observed behavior patterns. And finally, the parametric and conceptual models can be used as a basis for defining policy debates in the area of weapon acquisition and defense funding. At this time, too much of the policy debate is concerned with symptoms rather than structure, so this model may aid in the process of focusing debate on key issues of system structure.

During the validation process it was observed that model behavior was significantly different during periods of growing defense spending than it was during periods of falling defense spending. In general it appeared that periods of rising funding resulted in a slower rate of increase in weapon unit cost and

Table 10. -- Confidence Building Test Results

Test	Level of Confidence
Tests of Model Structure	
a 1. Structure Verification	High
a 2. Parameter Verification	Medium
a 3. Extreme Conditions	High
a 4. Boundary Adequacy	Medium
a 5. Dimensional Consistency	High
Tests of Model Behavior	
a 1. Behavior Reproduction	High
2. Behavior Prediction	*
a 3. Behavior Anomaly	High
4. Family Member	Low
5. Surprise Behavior	Low
6. Extreme Policy	Low
7. Boundary Adequacy	Low
a 8. Behavior Sensitivity	High
Tests of Policy Implications	
1. System Improvement	*
a 2. Changed-Behavior Prediction	*
3. Boundary Adequacy	Medium
a 4. Policy Sensitivity	*

a Core Tests

* This test was not performed

that during periods of constant or decreased funding that the rate of increase was much higher. This behavior prompted a policy experiment which is used to demonstrate how the model may be used to conduct policy experimentation which is discussed in the next section.

Policy Experimentation

The policy experiment which was chosen to demonstrate potential uses of the model illustrates how the model can be modified to represent the implementation of alternative policies and how the model behavior under different policies can be evaluated. Two runs of the model were made under different conditions in order to determine how the system might react under differing policy conditions. The measure of interest was the unit cost of the weapon systems which are produced. The question was, how does unit cost react to different policies and why does it behave as it does? This second question, why does unit cost behave as it does under the different policies, is important as it can aid decision makers in gaining a better understanding of the the relationships between the system's structure and its behavior. This often is as important as the answer to a specific policy evaluation.

During the model validation procedure, it was noted that the model produced annual rises in weapon unit costs more slowly during periods of increasing defense spending. This led to a basic policy question of whether sharp increases in defense spending followed by periods of decreased

spending resulted in higher or lower weapon unit costs in the long-term . The first step in this demonstration policy analysis was a causal loop analysis. The overall system structure diagram, presented in Figure 10 of Chapter 4, provided the necessary amount of resolution. The required structure is shown in Figure 110.

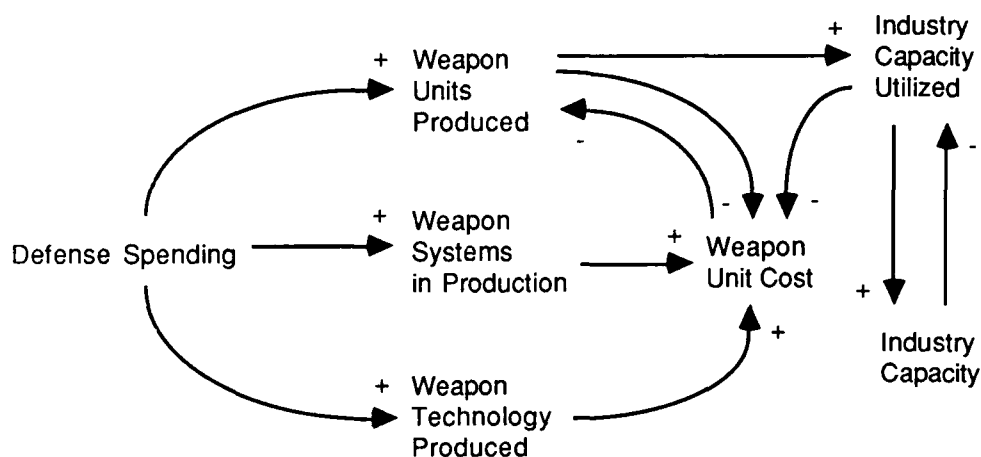

Figure 110. Defense Spending and Unit Cost

Analysis of the loop structure shown in Figure 110 indicates that as defense spending increases, the number of units produced per weapon system, the number of weapon systems in production and the technology produced all increase. When time is considered, however, it is obvious that increases in the number of weapon systems in production and the technology level of the weapons in production could not occur immediately and in fact might take a few years before these increases were effective. A change in the number of units produced of each system could, however, occur quickly which would act to reduce the upward pressure on unit cost and would increase the

industry capacity utilization. Although industry's response to increased utilization would be increased capital investment, the impact of increased investment also would not be felt immediately. So, the initial response of the system to an increase in defense spending should be either lower unit costs or at least a slower rise in unit costs. A number of years after the initial increase, the number of systems produced, the technology produced and industry capacity would all begin to rise. The effect of each of these variables increasing would be an increase in weapon unit costs. It is not clear from the loop analysis whether or not the increased production rate effect would negate the other forces that would act to drive up unit cost. It is clear, however, that if the increase in defense spending is short lived and followed by a decrease in spending levels, the rate of unit cost increase will certainly be higher after the rise and fall of spending than if there had been no change. This would occur because near the time that the spending begins to fall and production rates slowed, the new weapon systems, new technologies and new capacity that resulted from the spending increase would begin to come into operation. The impact of these effects taken in combination would probably be sharply reduced production rates and rapidly rising unit costs.

In order to test this policy using the simulation model, two experiments with the model were completed. The initial conditions for both runs were the 1960 initial conditions with the "Viet Nam War effect" and the "early eighties defense buildup effect" removed. These effects were removed to isolate fully

the effects of the experiment. The baseline experiment was allowed to run for thirty years and was compared to an alternative policy which was to increase defense expenditures at year seven for four years at a rate of 10% per year followed by a four year decline in the defense spending levels of 10% per year. The alternative policy will be referred to as the "volatile defense spending" policy. The increased level of funding over an eight year period resulted in a significant increase in cumulative defense expenditures. The question of interest was whether the system was able to accommodate relatively volatile changes in defense funding levels effectively, or whether the system would react in a way to negate the positive effects of the increased funds.

The baseline policy was run using the model described in Chapter 5 with two modifications. As noted, the increase in global tension corresponding to the Viet Nam war was removed and the "early eighties arms buildup" effect was also removed. This was done by setting both of these factors equal to zero ($VNE.K=0.0$ and $EEAB.K=0.0$). The volatile spending policy run also removed these factors with the exception that at time period seven, a 10% increase in the "defense spending level rate of change" was added using the STEP function described in Richardson and Pugh (1981). In time period eleven, a negative STEP was used which resulted in a net 10% decline in the defense spending rate of change. At time period fifteen, a positive STEP was added which negated the impact of all previous STEP functions. The resulting defense spending levels for the two runs are shown in Figure 111.

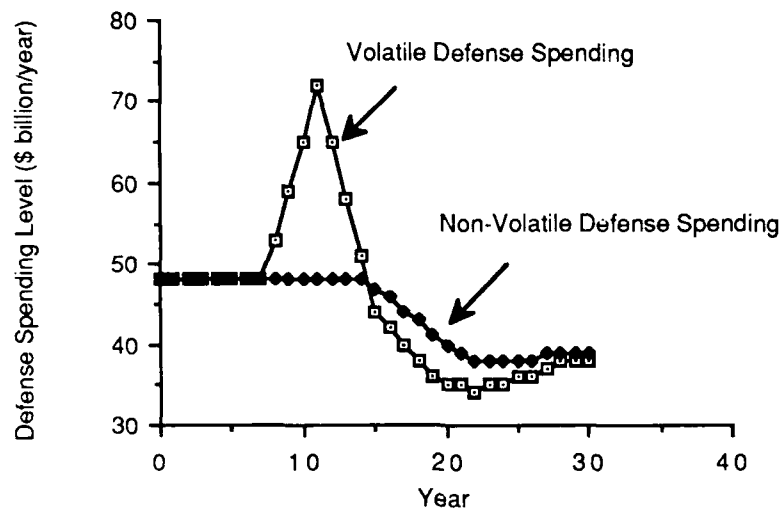

Figure 111. Defense Spending Comparison

The decrease in defense spending beginning in year 14 which affected both runs was a result of the building pressure of the deficits which occurred in that time frame. The other impacts on defense spending rate of change, global tension and perceived military capability, did not have much impact during this period because of the relative advantage that the United States had in military capability in 1960 which was the year corresponding to the initial conditions for these runs.

As would be expected during periods of rising defense spending, production rates for weapons in production were increased and the result was an increase in efficiency because of the low level of initial capacity utilization in the defense industry (around 50%). Gansler (1980) claimed that capacity utilization of approximately 80-90% would lead to the most efficient production of weapon systems. In addition to increased production rates of "systems in

production," the increase in funding also resulted in more units per system being produced, more systems in production and development and lower unit costs as long as the funding increase lasts.

One other important impact of the increased defense expenditures was an increase in the Federal deficit. The impact of the deficits was a sharper decline when defense spending falls with the level falling below the level of defense spending when no intervention took place to increase spending. The larger deficits acted to increase tax rates in the future which resulted in lower deficits in the out-years but the impact on defense spending was on balance mostly negative. A comparison of the deficits generated by the two model runs is shown in Figure 112.

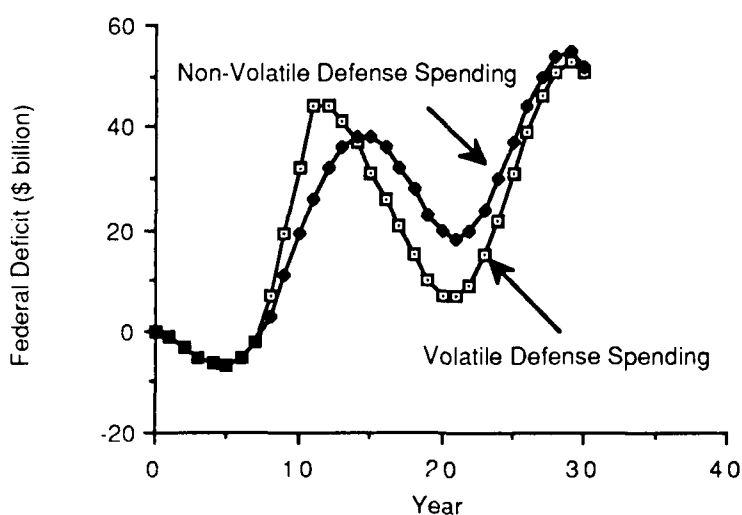

Figure 112. Comparison of Federal Deficits

At the end of the 15th year when the intervention was complete the production rate, the number of units of each system produced in a given year, was already lower than in the case where funding remained steady. This was because the production rate was very sensitive to annual funding and unit cost changes, whereas other production variables such as number of units produced of a weapon system, the number of systems in production and production period were slower to change. In fact, the production rate fifteen years after the intervention occurs was still lower and the result was less efficient production and higher unit cost. The relationship between the production rates for the two runs is shown in Figure 113.

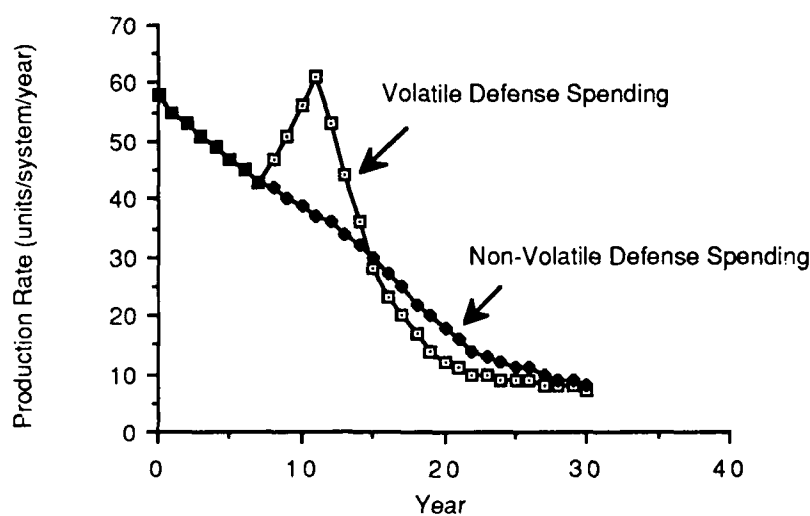

Figure 113. Comparison of Production Rates

A factor which acted to reduce production rates further in times of falling defense spending was the impact of the number of systems in production and

the number in development. During periods of rising funding, the number of systems which began development was increased and the number of systems which begin production also was increased. Once these systems enter the pipeline it was not easy to quickly reduce them. This is the so-called "bow-wave" effect that a number of authors discuss relative to the arms buildup of the early 1980's (Fallows 1986). As funding levels begin to fall, the reduction in the number of systems in production lags behind, and the only alternative is to reduce the rate of production and increase the production period. The relationship between the number of systems in production for the two runs is shown in Figure 114, and the comparison between production periods is shown in Figure 115.

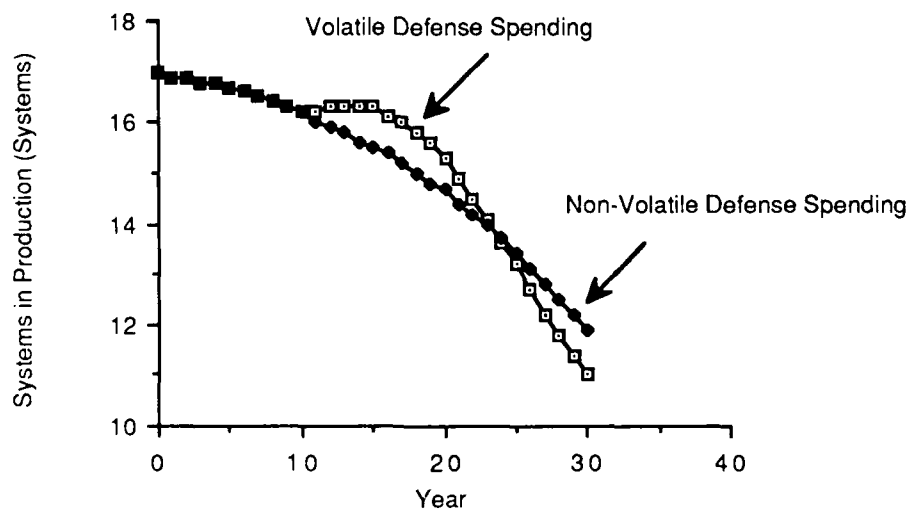

Figure 114. Comparison of Systems in Production

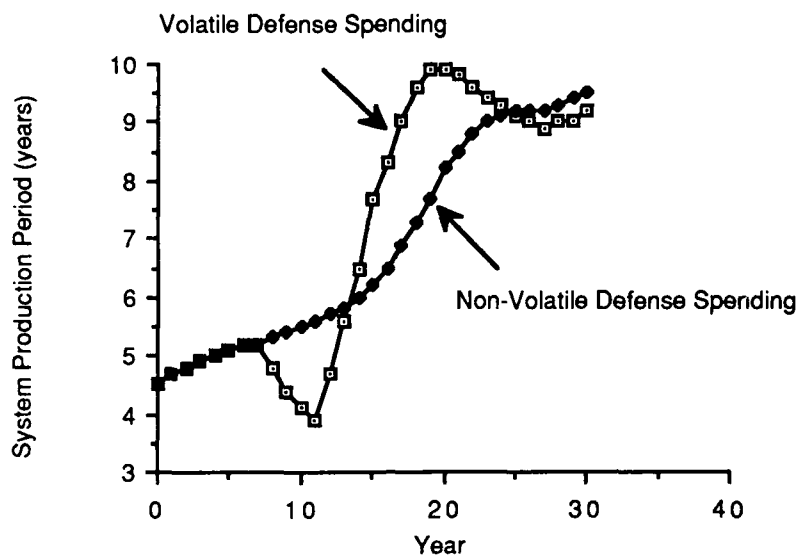

Figure 115. Comparison of System Production Periods

In the final analysis, perhaps the most important question is how many units of each system are being produced and how many systems are in production. In combination, these two variables determine at what rate the weapon inventory of the United States is growing. Related to this question is the one of how much is being paid for each weapon produced, because it is the unit cost that determines the effectiveness of the defense dollars. The number of units produced over the total production period changes as a function of changes in the unit cost and the funds available for the acquisition of weapons. The comparison of units per system values for the two runs of the model is shown in Figure 116. Not only are fewer weapon systems being produced with the experiment which contains the increased level of defense spending shown in Figure 114, but also, fewer units of each system are being produced. Figure 116 indicates, over the thirty year period shown, that there is not much

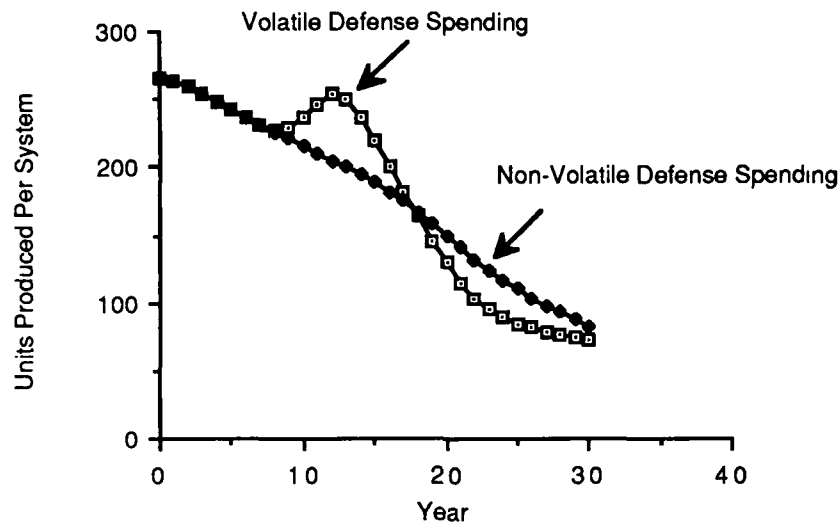

Figure 116. Comparison of Units Produced Per System

difference in the cumulative effect of the two policies. It must be noted, however, that the "volatile spending" policy results in fewer units produced per system well into the future. After fifty years the "volatile spending" policy results in 25.7 units per system and 5.3 systems in production, while the other policy results in 28.1 units per 5.5 systems. This long-term effect is due, of course, to the increased unit cost with the "volatile spending" policy.

The final measure of system effectiveness is the unit cost of the weapons procured. In this case, the run with the increased defense spending compares unfavorably with the results of the run with no increase in spending levels. This is shown in Figure 117. The reasons for the difference in the unit cost have already been discussed and have been explained in terms of system structure. The results of this policy experiment indicate that rapid increases in

defense funding levels may in fact do more long-term harm than good if the funding level cannot be sustained.

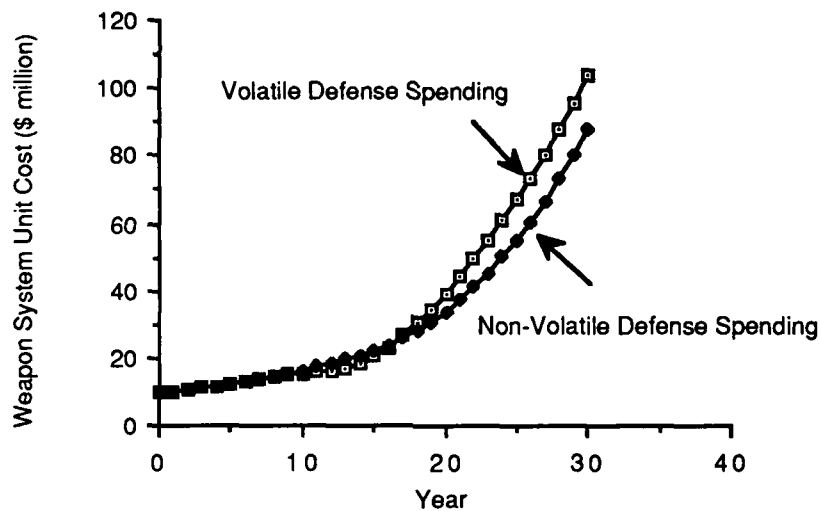

Figure 117. Comparison of Unit Cost

This policy experiment demonstrates the way in which the model is able to be used as a policy analysis tool as well as the way in which it provides additional insights into the relationship between system structure and system performance. It is recognized that additional structures may need to be added to the basic model to perform certain analyses, but that is the nature of using simulation models in a policy evaluation setting. The model described in Chapter 5 sets forth the basic structures of the weapon acquisition system and provides a framework for specific analyses. No other model like the one developed in this research currently exists which can be used to evaluate the macro policies of weapon acquisition. Further experimentation and validation

are required in order for this model to gain the confidence of weapon acquisition policy makers, but this is nature of policy modeling.

CHAPTER 7

SUMMARY AND CONCLUSIONS

Introduction

Presented in this chapter are a summary of the research discussed in the preceding six chapters and the conclusions which can be drawn from it. The research presented was guided by the problem statement in Chapter 1. The problem was multifaceted and dealt with 1) determining the nature of the decision process and information structure in the "defense acquisition system"; 2) developing a conceptual model of the system; 3) developing a computer-based, policy-evaluation model; and 4) demonstrating the value of the models as policy analysis tools. These components of the research problem will be addressed in this chapter.

The major objective of the study, stated in Chapter 1, was "to integrate the theoretical frameworks which have been used in defense acquisition policy studies into a single framework and use it to develop a simulation model for studying long-term system behaviors." This objective and the research propositions, stated in Chapter 1, which it spawned will also be evaluated in this chapter.

The discussion and conclusions will be divided into five categories: first,

those conclusions which can be made based on a review of the literature presented in Chapter 2; second, those conclusions which deal with the modeling process which was discussed in Chapter 3; third, those conclusions concerning the development of the conceptual model which was presented in Chapter 4; fourth, those conclusions which have to do with the parametric model presented in Chapter 5; and fifth, conclusions concerning the direction of future research in the area of weapon acquisition management. A summary of the conclusions dealing with the interviewing process is included in Appendix A.

Literature

As stated in Chapter 2, the literature which has been published in the area of weapon acquisition management is quite diverse and fragmented. This is not a condemnation of the literature, rather it is one of its strengths. The broad range of perspectives and analysis methodologies helps to ensure that the research does not become method bound or emphasize theory over application. There are, however, some shortcomings in the literature covering the area. No studies were found which integrated all of the important aspects identified in the literature. These aspects include the demand created by threats to national security, the fiscal limits placed on the system by the national political and budget process, the resource allocation and management process at the national and Department of Defense levels, the interaction of the requirements determination and weapon design processes, and the interaction

between defense policies and the defense industry structure. No truly systemic studies have been reported. A further conclusion is that policy studies which ignore any of the key relationships will not be able to provide firm support for any system policy recommendations. The policies which have been recommended have been based on something less than a system perspective, so the exact impact of them on the overall behavior of the system cannot be determined accurately.

With few exceptions, the literature has concentrated on symptoms of the weapon acquisition problem, rather than on analysis of the system structure which leads to such behavior. Most of the studies have viewed the problem from the perspective of either the defense industry (Gansler 1980), the process within the Department of Defense (Clark et al 1985, Fox 1974, Peck and Scherer 1962), the national political process (President 1986, Stubbing 1986), or the superpower confrontation (Fallows 1981, Luttwak 1984). This research introduced the notion of dealing with each of these perspectives simultaneously by treating the system as the interaction of related sectors or subsystems corresponding to the defense industry, the Department of Defense, the national budgeting and priority setting process and the interaction of the superpowers in the global arena. Only a few of the studies reviewed have investigated the interaction of pairs of the sectors, and none of the studies attempted to integrate all four of the sectors which are described in this research.

Many of the studies which propose reform policies have been based solely

on subjective analysis. These studies are characterized by the use of interview data along with personal experience. The shortcomings of these studies is that too often the interview respondents did not represent a cross section of the many perspectives of the system and many of the conclusions based on interview comments were not supported with objective data. With few exceptions, the more objective, analytical studies have been oriented to micro issues and problem symptoms rather than system structure. The analytical studies have utilized several quantitative analysis techniques including economic analysis, econometric analysis, statistical analysis, and simulation modeling. These studies have generally lacked the holistic, system perspective that would help them focus upon the differences between symptoms and causes of behavior. Three exceptions to this general trend in the analytical studies are those by Peck and Scherer (1962), Gansler (1980) and Clark, Whittenberg and Woodruff (1985). These studies took a more systemic view of the acquisition process, but the studies were limited because they considered at most, the interactions between the defense and industry sectors.

Most studies of the weapon acquisition system have been descriptive and have provided very little empirical basis for the policy recommendations which have been made. One reason for the lack of truly effective normative studies is that the methodologies which have been used have not been conducive to testing any policy options which are developed. Only the Clark et al (1985) study included a model which could be used to experiment with and evaluate

policy alternatives and it was narrowly focused on the Defense System Acquisition Review Council review process that manages procurement within the Department of Defense.

Modeling

The conclusions which can be drawn from the modeling effort discussed in this study parallel closely the guidance on systems modeling which is included in such sources as: Shannon (1975), Legasto, Forrester and Lyneis (1980), Randers (1980), and Banks and Carson (1984), all of which are recommended for those who plan to undertake a system modeling project. The modeling effort which was reported in this research substantially validates the system science paradigm that was discussed in Chapter 3.

Any significant system modeling effort such as this should proceed with a modeling partner (or modeling team) who maintains very close contact with the progress of the project at all times. In fact, a small modeling team is most likely the best strategy. Further, at least one of the modeling partners should have extensive applied experience in systems modeling and the other experience with the system being studied.

Significant effort was devoted to producing a valid conceptual model prior to beginning the parametric modeling effort. By creating a strong conceptual framework, fewer conceptual problems were encountered during parametric modeling than otherwise would have been the case. This is the preferred

method because conceptual problems uncovered during the parametric modeling phase may not be recognized immediately and can result in wasted effort. Validation of the conceptual model using interviews with system experts with diverse perspectives not only refined the conceptual model and increased confidence in the model, but it also resulted in the correct presentation of important system concepts. This is very important with respect to the value of the model as a tool for use by other analysts and policy managers. In order to perform the validation, frequent review of the model and its description by system experts is required.

The top-down, modular approach to modeling, which is recommended by Shannon (1975) and others, aids the modeler in stressing system structure rather than system behavior in the evolving model. Concentration on structure in both modeling phases is a certain key to success as is diligent real-time documentation of the model and the reasoning which supports the model.

A final conclusion which is supported by this research is the importance of a good combination of software and hardware in which to implement the parametric model. The combination of a hard-drive micro computer with a high resolution graphics monitor and the Professional DYNAMO modeling language proved to be a very powerful combination, and far superior to the alternative of using a mainframe computer. The micro-computer allowed for a dedicated computer and superior graphics and provided compilation and simulation times which in elapsed time were superior to that available with a mainframe.

Conceptual Model

The conceptual model, presented in detail in Chapter 4, is a graphical representation of the four interacting sectors which make up the weapon acquisition system. The four sectors are the threat sector, the national sector, the defense sector, and the industry sector. The threat sector details the interaction between the Soviet and American military capabilities and their impact on global tension and national policies. The threat sector provides the demand pressures for military capability which result in increased defense expenditures. The national sector details the relationship between the American economy and the Federal budget in general, and the annual defense expenditures specifically. The defense sector details the process by which the resources that are allocated to defense are converted into military capability. Military capability in this sector and the threat sector is made up of four components: readiness, weapon inventory, weapon technology, and intelligence resolution. The final sector is the industry sector in which the cost of producing the weapon systems is determined as a result of industry structure and its interaction with the procurement policies determined in the defense sector.

The first research proposition from Chapter 1 stated that "the causes of rapidly increasing unit costs for United States weapon systems can be effectively modeled conceptually based on the interactions between" these four sectors. This proposition was tested primarily using the review of the literature

and preliminary interviews and was found to be supported throughout the research process, both during the modeling phases and the interviews which were used to validate the conceptual model.

The second research proposition from Chapter 1 stated that "the complex interrelationships among the variables in the acquisition system can be effectively represented in a conceptual model which highlights pair-wise interactions and identifies information feedback structures." The reactions of the people interviewed to the conceptual models was mixed, but the negative reactions generally were based on a desire to see a less complex model. These reactions led to a more parsimonious model (see Appendix A for details). The system, however, is extremely complex, and so a certain level of complexity was necessary for the models to be of any real value in policy discussions.

The advantage of the modeling methodologies which were used in this research is that the structure and boundaries of the system of interest are explicitly stated and clearly observable. The graphical conceptual model allowed the model to be viewed in a system representation and provides a systems framework for the debate on weapon acquisition policies which has been missing. The graphical model not only provides the basis for debate concerning the acquisition of arms but also facilitates debate of the model's structure. This feature helps to ensure the model's validity as it is constantly exposed to criticism that will build users' confidence in the model each time that it is employed in analysis.

The conceptual model is based on causal relationships and structure, not on symptoms of behavioral outcomes. This allows users to gain insight into how the system structure results in the observed behaviors and allows them to formulate policies to produce desired behaviors. The model's emphasis on system structure rather than system behavior enabled experts representing conflicting points of view about policy alternatives to find common ground. Such a model lessens the reliance on emotion and political considerations, and lessens the tendency to assign blame for system behavior to specific organizations. The conceptual model was also a useful tool for validating the concepts in the parametric model.

Parametric Model

The parametric model is an interpretation of the conceptual model using the DYNAMO simulation language (Richardson and Pugh 1981). It mathematically integrated the four interacting sectors into a single experimental structure. The model represents the system in terms of its stocks and flows of material and information and constitutes a consolidated theory about the decision and information structure of the weapon acquisition system. The parametric modeling process was guided by the conceptual model which had been validated during numerous interviews (see Appendix A for details). The choice of parameters was based on two criteria; agreement of parameter values with known system parameters and agreement of model behavior with

observed system behavior since 1960.

The pressure for increased defense expenditures stemming from comparisons of Soviet and American military capabilities and due to changes in global tension levels is mathematically represented in the threat sector. The actual level of annual defense expenditures is mathematically represented in the national sector by integrating information concerning the threat, global tension and the current Federal deficit. Mathematical structure in the defense sector models the distribution of defense resources among the four competing military capabilities based on net assessments of Soviet and American capabilities. Within the defense sector, decisions as to how many units of each weapon system would be produced, the number of systems beginning production, the number of systems cancelled and the level of weapon technology produced were modeled. The industry sector contains mathematical structure to represent the decisions concerning weapon system production, the level of weapon technology produced and investment policies. These variables interact to determine the unit cost of the weapons.

The third research proposition stated that the "complex interrelationships among the variables in the acquisition system can be effectively modeled parametrically as a system of difference equations." The DYNAMO simulation language is based on a difference equation format so the use of DYNAMO facilitated the modeling process because of its ability to effectively model information feedback structures. The one drawback to using the DYNAMO

language for this research was the inability of the language to model discrete concepts such as the addition of discrete chunks of capital or discrete weapon systems. Some type of combined continuous-discrete model may best deal with this feature of the system.

The fourth research proposition stated that the "influence of the threat on the weapon acquisition system can be effectively modeled by using the relationships between Soviet and American military capabilities, political objectives and domestic fiscal constraints." The model structure which corresponds to this proposition was supported during the literature review, the interview process, which was largely aimed at validating the conceptual model, and during the validation of the parametric model.

The fifth research proposition stated that the impact of the national political agenda and the fiscal constraints on the weapon acquisition system could be modeled effectively as a macroeconomic system relating GNP, Federal spending, the Federal deficit, consumption, interest rates, and net investment. This structure was supported during all phases of the research and the model was able to reproduce observed system behaviors quite accurately as was demonstrated during model validation which is detailed in Chapter 6.

The validation of the conceptual model was accomplished largely during the interview process which is detailed in Appendix A. The validation of the parametric model followed the procedure described in Forrester and Senge's (1980) seminal article about validation of system dynamics models. The

process consisted of building confidence in the model by using a series of tests aimed at validating the structure of the model, validating the behavior of the model and validating the policy implications of the model. The individual tests and their results are described in detail in Chapter 6. Also described in Chapter 6 are the types of policy analysis for which the model can be used. An experiment was performed in order to demonstrate how the model can be modified to evaluate individual policy alternatives. The experiment compared the impacts of volatile defense expenditure streams, characterized by short-term increases in defense expenditures, with relatively steady expenditure streams. The experiment indicated that the more volatile pattern of defense expenditures can result in higher unit costs for weapons in the long-run as well as lower levels of weapon inventories. Policies which could be implemented to limit the impact of volatile defense spending would be the use of longer term, multi-year budgets which correspond to the five year defense plans now in use.

Like the conceptual model, the structure of the parametric model is explicitly stated so that each assumption about the system's structure can be debated and validated to the extent possible. The parametric model allows for objective evaluations of different policies based upon these explicit assumptions. The parametric model allows for a more structured analysis than is possible with the conceptual model, and for observation of the impact of time and information delays on the behavior of the system.

While validation of a model is never complete, the model in its current form

can be useful as a policy analysis tool. With proper handling of its structure, the model can be used to evaluate policy alternatives at the national policy level. Primarily, it is useful in its current form for evaluation of a variety of possible defense funding policies, acquisition policies, and industry management policies.

Future Research

Future research in the area of weapon acquisition management should stress the broad systemic perspective which has been taken in this research and use research methodologies which allow the policy alternatives which are developed to be tested fully. The further use of the model which is presented here would serve two purposes. First it would further build confidence in the model, and second, it would provide a consistency to the analysis which has been missing. The debate concerning weapon acquisition policy tends to be very political and this methodology of policy analysis has the ability to remove some of the highly charged political aspects of the debate. Some of the subjective studies of the acquisition system have placed the blame for rising weapon costs and the perceived inefficiencies in arms procurement on a misguided propensity to build extremely complex weapons without regard to threat considerations (Fallows 1981, Luttwak 1984) or on some sort of big business bias within the Department of Defense (Fitzgerald 1972, Rasor 1985) which results in a de facto institutionalization of waste, fraud and abuse. None

of these studies have researched whether the behaviors which they have found could be due to some inherent system structure. Instead they have focused on symptoms and problem behaviors and have found "experts" with an explanation for why the system behaves as it does. Usually, the explanation is based upon an interpretation of the system's behavior which is not fully supported by the empirical data found in the objective studies. The model developed in this research is able to explain the behavior of the system in terms of the structure of the system without resorting to unsupported interpretations of past system behaviors. This can have the effect of focusing the debate on the structure of the system rather than on peripheral political issues.

Further analysis using the model will require modifications to the model in order to perform specific analyses. This was explained in Chapter 6 with the policy experimentation which was performed. The rate equations generally correspond to decision structures within the system and they can be modified in order to reflect a change in policy. Additional policies can be implemented by modifying the "desired" level auxiliary equations. As an example, the production cancellation rate equation could be modified so that more systems were cancelled during periods of declining production rates. This would implement a policy of reducing the number of systems in production rather than reducing the rate at which the systems are produced, which tends to increase the rate of cost growth. This policy was suggested by Clark et al (1985).

Future research to determine the impact of using a continuous simulation language such as DYNAMO to model a system which has continuous and discrete characteristics is recommended. Further modeling using a hybrid language which allows for both continuous and discrete modeling to be combined in a single model would allow the model to reflect more accurately the discrete nature of weapon system production and industry capital improvements. The model presented in this research does not reflect discrete weapon systems moving through the development and production process, nor does it reflect the addition of plants and equipment in discrete units. The impact of not modeling discrete weapon systems is unknown at this time. Additional research should use the model developed here as a starting point and then modify the defense weapon subsector to reflect the discrete development and production of weapon systems. Policy analyses using the original model and the modified model would allow a comparison of the two models to determine whether the modifications were of any true value.

Summary

The four facets of the original problem statement have been dealt with in the course of the research presented here. The nature of the decision process and information structure in the defense acquisition system has been carefully detailed in the conceptual model presented in Chapter 4 and the parametric model presented in Chapter 5. The conceptual model was subjected to a

detailed review and critique during the interview process and is considered to be a quite valid model integrating the impacts of the threat, national priorities, fiscal constraints, defense policy and industry structure. Finally the conceptual model provided the framework for a parametric model which has been demonstrated to be a valuable policy analysis tool in the area of weapon acquisition. A summary of the conclusions discussed in this chapter is presented in Table 8.

Table 11. -- Summary of Conclusions by Category

Category	Conclusions
Literature	<ul style="list-style-type: none"> * No studies have integrated all of the important aspects of the weapon acquisition problem * Policy studies which ignore any of the key aspects are suspect in terms of their policy recommendations * Only one study (Clark et al. 1985) have provided a methodology for testing policy recommendations * Policy recommendations are largely based on subjective analyses * Objective/quantitative studies have typically investigated relatively micro policy issues
Modeling	<ul style="list-style-type: none"> * The system science paradigm (Shannon 1975) was further validated * A modeling partner or team is required for this kind of effort * Maximum effort should be spent on development of a valid conceptual model * The top-down and modular approaches to modeling (Shannon 1975) were very effective and are recommended

Table 11. -- Summary of Conclusions by Category Continued

Category	Conclusions
Conceptual Modeling	<ul style="list-style-type: none"> <li data-bbox="403 625 1447 730">* The causes of rapidly increasing weapon unit costs can be effectively modeled conceptually based on the interactions between the four sectors identified in this research (threat, national, defense, industry) <li data-bbox="403 768 1447 873">* The use of causal digraphs, which highlight pair-wise interactions between system variables, was very effective for presenting complex system structures <li data-bbox="403 911 1447 1014">* The conceptual model presented in Chapter 4 emphasizes system structure and by doing so lessens the reliance on emotional and political considerations in policy discussions
Parametric Model	<ul style="list-style-type: none"> <li data-bbox="403 1129 1463 1234">* The DYNAMO simulation model presented in Chapter 5 is an effective system representation of the complex interrelationships among the variables in the weapon acquisition system <li data-bbox="403 1272 1463 1304">* The simulation model is a useful policy analysis tool <li data-bbox="403 1341 1463 1413">*The simulation model allows policy analysts to observe the impact of time delays in information and material flows
Future Research	<ul style="list-style-type: none"> <li data-bbox="403 1528 1463 1591">* Further use, modification and validation of the existing conceptual and simulation models <li data-bbox="403 1629 1463 1665">* Determine the desirability of integrating discrete and continuous models

APPENDIX A

THE INTERVIEW PROCESS

Introduction

The interview process which is described in this appendix was an integral part of the research process described in Chapter 3. As shown in Figure 118, the interviews were an important step in the modeling process. The steps in the research process which are discussed in this appendix are shown inside the boundaries of Figure 118, which was first presented in Chapter 1. This appendix will describe the role of the interviews, detail the interview process, and make some recommendations based on the experience.

The interviews conducted in conjunction with this research served multiple purposes, including the determination of the scope and objective of the study, defining the system and model boundaries and components, validation of the conceptual and parametric models, and validation of the policy experimentation. The interviews took place over a span of twenty months between August 1986 and March 1988. A characterization of the interview process is presented in Figure 119. This model of the interview process was used as a framework for this appendix.

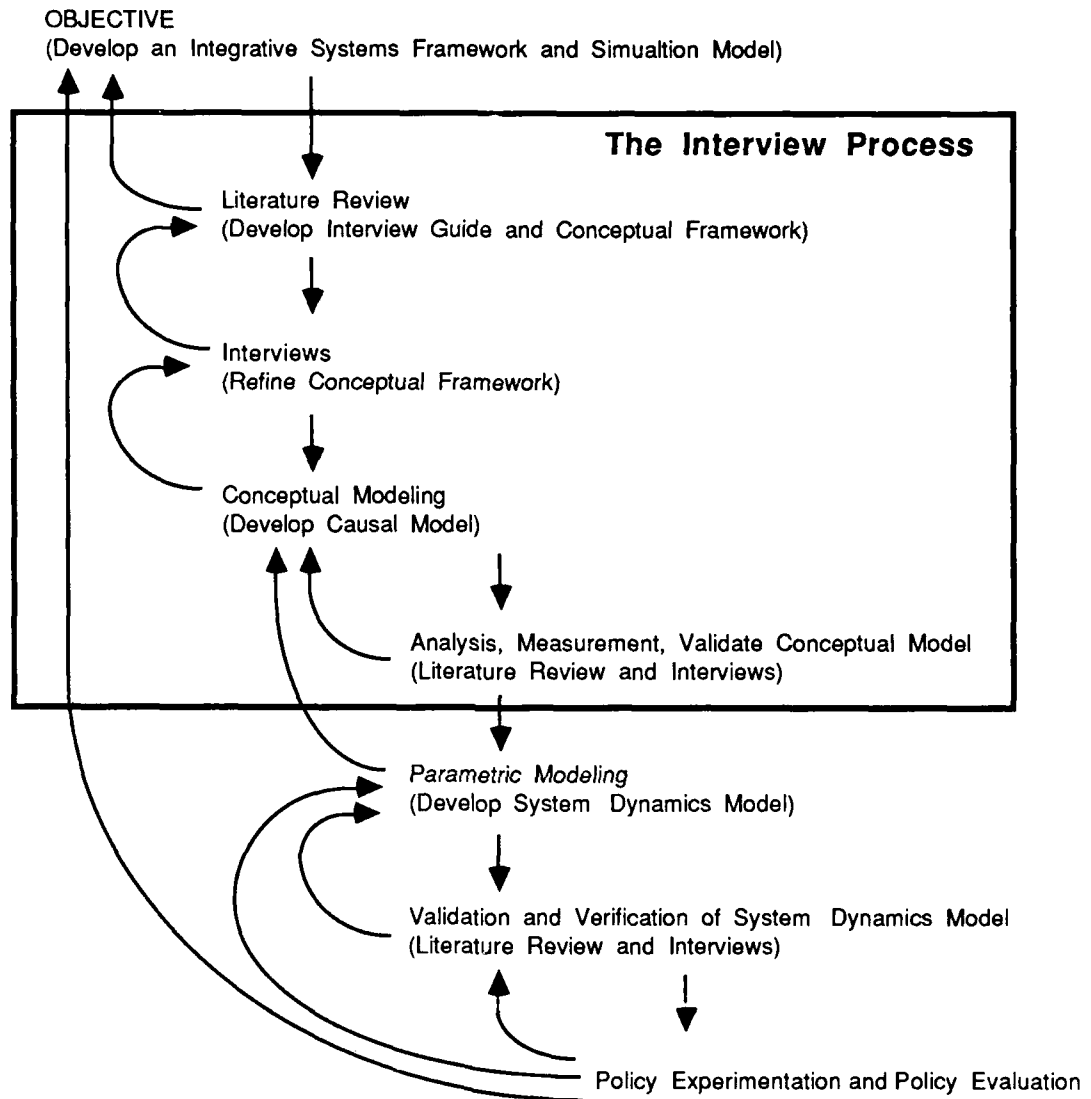

Figure 118. The Research Process

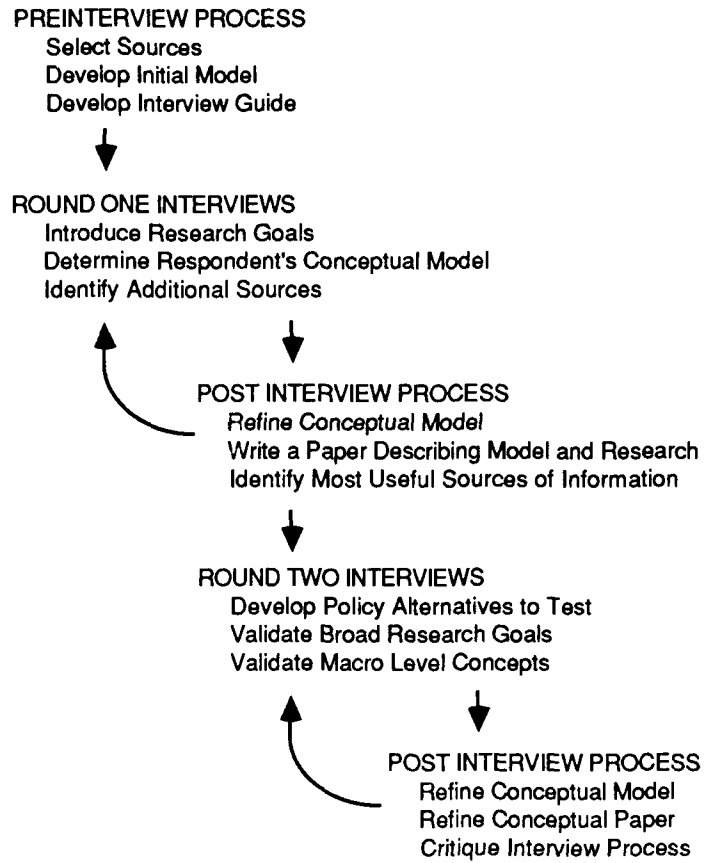

Figure 119. The Interview Process

Although, each round of interviews was accomplished to support a specific research goal, the nature of these interviews was such that the discussions were wide ranging and were not always confined to a single task or set of tasks. Generally each interview was structured based on the desires of the respondent and the primary purpose of the interview from the research perspective. The interviews were not tape recorded at the request of the respondents because of the political sensitivity of the topic and the desire of the majority of the participants not to have their comments directly attributed to them in print. While this undoubtedly resulted in a loss of some useful information, it also provided an atmosphere where the respondents were quite open and frank with their observations and opinions. During the interviews, extensive notes were taken by the interviewer and following the meeting, the notes were transcribed into a more complete record of what was said during the interview. Because many of the respondents did not want to have their comments attributed to them specifically, none of the comments or ideas which resulted from an interview are cited specifically in the study. The material was, however, used extensively in structuring the conceptual model and in framing the research questions.

Respondent Selection

The selection of the respondents who participated in this research was accomplished based on an iterative scheme. Interviews were requested from

Congressional staffs representing both political parties from both the Senate and House of Representatives; the Department of Defense, including the Office of the Secretary of Defense, the Office of the Secretary of the Air Force, the Chief of Staff of the Air Force, and the Joint Chiefs of Staff; the aerospace industry; the Office of Management and Budget; the Congressional Budget Office; Senior Air Force leadership; and noted authors in the field. A complete list of the interview respondents, grouped by their area of expertise is presented in Table 12. A list of the full name and position of each respondent along with the date and time of the interview is presented in subsequent sections of this appendix.

One of the few drawbacks in trying to interview senior executives and policy analysts is that given the extensive demands on their time, their schedules often do not allow them to take the time to grant interviews. Additionally, some are reluctant to be interviewed because of their positions. A common response to letters requesting interviews with senior executives in the Congress or the Office of the Secretary of Defense was to decline altogether or to have an assistant offer an interview. Another response was to allow only a very short time for the interview, which in some cases, allowed only time for introductions and for the executive to ask general questions about the research.

Because of the reluctance of some active duty military personnel to participate in such a sensitive study, interviews were sought with recently retired officers and former executives. Generally, these individuals were much

Table 12. -- Interview Respondents

Congress	Executive Branch		Industry	Academic/ Analytical
	DOD	Other		
R. Emmerichs	J. Anderson	J. Boucher	N. Augustine	R. Emmerichs
J. Etherton	R. Carver	A. Burman	H. Driessnack	J. Gansler
R. Hale	C. Cunningham	M. Connolly	J. Gansler	D. Hicks
P. Heilig	H. Driessnack	R. Cooper	D. Hicks	E. Luttwak
	C. Gabriel	J. Zimmerman	D. Schillerstrom	D. Zakheim
	J. Gansler		P. Sullivan	
	D. Hicks		E. Thorson	
	K. Konwin			
	D. Latham			
	R. Marsh			
	J. Russ			
	W. Sadler			
	A. Sherbo			
	T. Spangrud			
	J. Stewart			
	E. Thorson			
	B. Wood			
	D. Zakheim			

Note: Names that appear twice indicate that the person has held separate positions in each of the categories for which he is listed.

more inclined to grant interviews and the interviews tended to be more informative than those with officials currently serving in the Department of Defense. Possibly, these respondents had found time to consider the acquisition system's problems in a broader context after being relieved from the day-to-day demands of their jobs. This contrasted with an observation that executives still involved day-to-day in the system tended to take shorter term outlooks and tended to be more interested in problems of the day rather than the long-term problems and dynamics of the weapons acquisition system. This observation can have important implications for system behavior if it is valid, with the most important effect possibly being felt on efforts to reform the system. If current executives do not have time to recognize and deal with the systemic problems which they face and that have been recognized as problems by various commissions, then it is quite likely that any suggested reforms will be circumvented by the organizations which they impact.

First Round Interviews

The purpose of the first round of interviews held during August 1986 and March 1987 was to: 1) make contacts which would be helpful later in validating the conceptual and simulation models, 2) determine the problem behaviors associated with the acquisition system, 3) identify potential policies which might be used to deal with these behaviors, 4) identify future problems and the direction of change of the system, 5) determine the important variables,

relationships and boundaries of the acquisition system, and 6) to identify the key structures which determine the behavior and performance of the acquisition system. The schedules for these interviews are presented in Table 13 and Table 14. In retrospect, an additional objective should have been included, and that was to determine additional sources of information and data. In fact this kind of information did emerge from some of these interviews. If, however, such a goal had been explicitly recognized from the beginning, the process of building a useful, supportive interview sample may have been easier. For example, a question which should have been asked explicitly was "what do you think of the objective of this research and whom do you suggest I talk to about this specific study?"

Because the purpose of these first interviews was multifaceted, and because these are quite different perspectives of the acquisition system, the interviews were conducted in a semistructured format designed to allow the respondent to expound as much as possible without being influenced by specific interview questions. The questions which guided these first interviews were:

"What do you view as the major problems with the current weapon acquisition process?"

"What do you think are possible policies or strategies for dealing with these problems?"

"What are future problems about which policy makers must worry given that the structure of the acquisition system does not change significantly?"

"What are the important structural characteristics of the weapon acquisition process which make it behave as it does?"

"What are the important variables and relationships which must be incorporated into any policy maker's personal model of the system?"

In each interview these questions were asked in an order which corresponded with the flow of the discussion, not necessarily in the same order for each interview. In many cases only one question had to be asked in order to get the respondent started on a long discourse which answered each of these questions. In other cases respondents did not view the problems associated with weapon acquisition in a systemic framework and some of the questions were then not applicable.

Following the first round of interviews in August 1986, participants who had been helpful were contacted to determine other useful sources and to aid in the process of obtaining interviews with other respondents or with people who had not been receptive to an initial interview. Both of these tactics worked very well. Being able to say "so and so talked to me and suggested that I talk to you" was very helpful in opening some doors which had been closed before. While the interviews which were conducted with the assistants were not necessarily useful as sources of data, these interviews often seemed to be a necessary first step in order to be able to see the assistant's boss during the next round of interviews. The second set of interviews was held with a much more focused group of respondents because the groundwork had been laid with the August 1986 interviews.

Table 13. -- Interview Schedule, August 1986

4 August 1986	1100-1245	Mr. Paul Heilig, Senate Budget Committee Staff Member
	1300-1400	Mr. Bob Hale, Director for National Security, Congressional Budget Office
5 August 1986	1000-1100	Mr. John Etherton, Senate Armed Services Committee Staff Member
	1230-1315	Mr. Jim Boucher, Bureau of Economic Affairs, Department of Commerce
	1330-1530	Mr. Martin Connolly, Mr. Joseph Zimmerman, Mr. Robert Cooper, Office of Federal Procurement Policy, Office of Management and Budget
7 August 1986	1030-1100	Mr. David Schillerstrom, Director for Public Relations, Aerospace Industry Association
	1330-1420	Mr. John Russ, Principal Assistant to the Deputy Assistant Secretary of Defense, Comptroller
	1430-1530	Dr. Dov Zakheim, Deputy Under Secretary of Defense, Policy and Resources
12 August 1986	0930-1100	Col. Jim Anderson, Director of Program Costing, Comptroller of the Air Force
	1100-1130	Maj. Andy Sherbo, Information Management Branch, Comptroller of the Air Force
	1200-1330	Maj. Buddy Wood, Fighter Division, Air Force Studies and Analysis
	1415-1425	Lt. Gen. Truman Spangrud, Comptroller of the Air Force
	1500-1600	Mr. Richard Carver, Assistant Secretary of the Air Force, Financial Management
13 August 1986	0900-1030	Mr. Pat Sullivan, Procurement Division, Aerospace Industry Association

This second set of interviews, held in March 1987, was aimed at the same purpose as the interviews conducted in August 1986; however, interviews only were scheduled with individuals believed to possess macro-level perspectives required by this particular study. In retrospect, it seems that any information gained from the first round of interviews was a value-added benefit with the primary value of these interviews being the determination of those people likely to be useful as primary interview respondents.

The method of taking notes during the interview and transcribing them immediately afterward was adequate. However, it became clear that there simply is no substitute for having a voice recording of the interview. If the interview cannot be recorded, the transcribing must be accomplished as soon as possible after the interview is completed, otherwise too much information may be forgotten. Related to this point is the process of scheduling the interviews. Allowances must be made for the interview to start a little late. And, while most of the interviews were completed in about an hour, at least two hours should be allowed for each interview as at least thirty minutes should be allocated to transcribe the interview and adequate time to travel to the next interview should be scheduled. If the sites of the interviews are geographically separated, it can be very difficult to get more than one interview completed in the morning and one completed in the afternoon.

Table 14. -- Interview Schedule, March 1987

16 March 1987	0900-1030	Dr. Jacques Gansler, Senior Vice President The Analytical Sciences Corporation
	1330-1500	Mr. Pat Sullivan, Procurement Division Aerospace Industry Association
17 March 1987	1000-1015	Dr. Edward Luttwak, Senior Fellow, Georgetown University Center for Strategic and International Studies
	1130-1230	Mr. Eric Thorson, Deputy Assistant Secretary of the Air Force for Financial Management
	1300-1430	Lt. Gen Hans Driessnack (USAF ret), Director Technical Programs, United Technologies Corporation
18 March 1987	0900-1000	Lt. Col Woody Sadler, Office of the Secretary of Defense, Personnel and Force Management
	1000-1130	Capt. Jake Stewart, USN, Office of the Secretary of Defense, Plans and Assessment
19 March 1987	0900-1000	Mr. Bob Emmerichs, House Armed Services Committee Staff Member
	1400-1530	Dr. Al Burman, Deputy Director Office of Federal Procurement Policy, Office of Management and Budget
20 March 1987	0830-1000	Gen. Robert Marsh (USAF ret), formerly Commander Air Force Systems Command
	1030-1115	Mr. Donald Latham, Assistant Secretary of Defense, Command, Control, Communications, and Intelligence

Second Round Interviews

The second round of interviews was conducted with the specific intent of validating the conceptual models which were generated with the information gathered during the first interviews. The schedule of interviews is presented in Table 15 and Table 16. In addition, the problem setting, system behaviors, and the potential policies which became the focus of the study were also presented for validation. Drafts of the conceptual models, and problem setting were included in a paper which was forwarded to the respondents for review about one month prior to these interviews. The paper was sent to those respondents who indicated that they were interested in the study and its results, but not only to those who *necessarily would support the content of the paper*. Indeed some of the best criticism came from those individuals who disagreed the most with structures included in the paper.

These interviews were conducted to answer specific questions about the models and the ideas included in the paper. Those who were interviewed had all read the paper and most of them provided a critiqued copy and were anxious to discuss specific concepts. One common thread to the comments was that the graphical models which were presented in this early draft were too complicated to be of any use to a decision maker. If the reviewer did not specifically talk about the graphical models then he was asked for his specific reaction to this kind of model, the models presented in the paper in particular, and for a reaction to the specific relationships which were included. The

Table 15. -- Interview Schedule, September 1987

10 Sept 1987	0900-1030	LGen Charles J. Cunningham (USAF ret), Senior Vice President of Aerospace, Mowell Financial Group Inc., formerly Commander of the Twelfth Air Force
16 Sept 1987	1300-1400	Dr. Jacques Gansler, Senior Vice President, The Analytical Sciences Corporation
	1500-1600	Dr. Donald Hicks, President Hicks and Associates, former Under Secretary of Defense for Research and Engineering
21 Sept 1987	1000-1100	LGen Hans Driessnack (USAF ret), Director Technical Programs, United Technologies Corp.
	1500-1600	Dr. Al Burman, Deputy Director Office of Federal Procurement Policy, Office of Management and Budget
23 Sept 1987	0900-1030	Gen Robert Marsh (USAF ret), former Commander Air Force Systems Command
	1430-1500	Dr. Dov Zakheim, Executive Vice President, Systems Planning Corporation
25 Sept 1987	0900-1000	Mr. Eric Thorson, Deputy Assistant Secretary of the Air Force for Manpower and Personnel
	1030-1200	Mr. Bob Emmerichs, House Armed Services Committee Staff Member

Table 16. -- Interview Schedule, March 1988

3 March 1988	1500-1630	Mr. Leroy Haugh, Vice President, Aerospace Industries Association of America, Inc.
4 March 1988	0900-1000	Dr. Jacques Gansler, Senior Vice President, The Analytical Sciences Corporation
	1040-1130	Mr. Bob Emmerichs, House Armed Services Committee Staff Member
7 March 1988	1000-1100	Dr. Donald Hicks, President Hicks and Associates, former Under Secretary of Defense for Research and Engineering, and Gen Charles Gabriel (USAF ret), former Chief of Staff, US Air Force
	1330-1530	Mr. Harvey Gordon, Director Government Business Relations, Martin Marietta Aerospace Mr. Norman Augustine, President Martin Marietta Aerospace*
8 March 1988	1000-1130	Mr. Edward N. Luttwak, Senior Fellow Georgetown University Center for International and Strategic Studies
	1640-1800	Gen Robert Marsh (USAF ret), former Commander Air Force Systems Command

* Note: Mr. Augustine was unable to keep his appointment, but he provided a copy of the paper with his written comments.

respondents were also asked if they felt that any key variables or relationships had been left out.

Nine interviews were set up to validate the emerging conceptual models. These subjects were chosen based on their willingness to help, their broad range of perspectives and their insights concerning the acquisition system and its problems. These respondents represented a wide diversity of opinion and backgrounds. Four of the nine respondents reacted negatively to the causal diagrams which were presented in the paper and commented that they were confusing and not appropriate or useful for a decision maker. Three of the nine reacted positively to the diagrams and suggested specific ways in which they could be improved. Two of these respondents might be accurately characterized as professional analysts who have had a great deal of exposure to similar models. In general those who did not have previous experience with these kind of models thought them to be of little utility and their comments centered on the paper which described and supported the relationships shown in the models.

In retrospect, the paper and the models were probably too detailed for these kind of interviews. The intent of the interviews was a validation of broad conceptual ideas concerning the acquisition system. The models and the paper which explained the relationships in the models were highly detailed descriptions of the system. Such descriptions are perhaps more useful for developing a parametric simulation model than for discussing broad policy

issues. The paper was approximately thirty pages long and the diagrams of sufficient complexity that at least an hour and a half would be required to read and understand the material in the paper. The paper and the diagrams should both have been more focused so that the interviews concentrated on the key structures which had been identified. In two cases, it was obvious that the respondent had only skimmed the paper and ignored the diagrams. It was equally obvious that in six cases the paper had been thoroughly read and critiqued.

The second set of interviews which were conducted to review the conceptual models were conducted with a revised draft of the paper which incorporated the comments from the earlier interviews. By this time the graphical models had been scaled down significantly and it was felt that the conceptual framework was well developed. This feeling was supported by the reaction of the reviewers to the paper, which in all cases was very positive. Comments tended to be directed at the macro issues which were addressed in the paper rather than the detail oriented discussions of previous interviews. Most of the comments were directed at system descriptions in the text rather than the graphical models. The interview schedule is presented in Table 12.

The most important data source during these interviews proved to be the written comments of the respondents (on drafts of the paper) concerning the conceptual models and their narrative descriptions. Because of this, any letter accompanying a system overview paper should request that written comments be provided. Once again, the interviews should be recorded if possible, and if not, the notes from the interview should be transcribed immediately. In either case, it is helpful to take notes on a copy of the draft that is being discussed.

Model Evolution

The evolution of the conceptual models, which provide the basis for the parametric models presented in this research, was strongly influenced by the interview process and the other data gathering processes. Most notably, the literature review was an extremely important step. The modeling process is described in Chapter 3 and will not be reviewed here. This section, however, will contain highlights of the role and impact of the interview process on the modeling effort.

In many ways, the interview process and the literature review were similarly hampered as mechanisms in developing a macro-oriented policy model such as that proposed in this research effort. A macro model requires a macro perspective, which was not common in either the literature or the perspectives of interview respondents. During the interview process, this difficulty was probably exacerbated by interviewees being selected for their

close proximity to the system and their potential to see the system from the desired higher level perspective. Unfortunately, finding an interview respondent both involved in the day-to-day problems of the system and also capable of viewing the system holistically and objectively proved difficult. People still involved in the system's operation all interpreted the system's behavior as stemming from one or two key structures or relationships. This was not uncommon among other respondents that were separated from the system. There were, however, notable exceptions.

Such a restricted view of the system is also quite common in much of the literature. By reducing the dimensions of the problem, people have found a way to deal with the system's complex structure and problems. Even some of the more complex models which have been developed by analysts and academics have concentrated on the interactions involved in at most two sectors of the system and in this way have significantly reduced the complexity and dimensionality of the system beyond what it truly is. The result of this tendency by "systems experts" to reduce the dimensionality of the system and its problems is to cause a researcher to concentrate on and visualize the system as a collection of systems of fairly significant detail rather than as a single complex system. Relationships which seem very important in explaining behavior in a complex subsystem at a lower level of resolution often came later to be regarded in this research as clutter in the integrated macro system model.

The decision to model the acquisition system as the interaction between

four sector models was made prior to the first interviews, and was based primarily on analysis of pertinent literature. Although many of the respondents that were interviewed had written on the subject of weapon acquisition, and none had proposed such a formulation, there was basic agreement from all of them that this macro perspective was useful and relevant. An indication of the respondents' biases, however, is revealed when it is noted that none of the respondents was interested in discussing the interrelationships among the four sectors. Rather they tended to discuss the relationships presented in only one or two of the sectors individually and commonly commented on the relationships hypothesized in the causal digraphs individually and independently.

This interest in the relationship of a single sector's behavior to the problems encountered in weapon acquisition is reflected in the literature as well. The result is that the modeler is lulled into concentrating on the sectors individually rather than keeping in mind their role in the larger macro model. This can be noticed in the evolution of the graphical conceptual models which were produced at regular intervals in the modeling process. Each interview or information source often resulted in some concept being added to the model because it impacted variables and relationships which were already included. Many of these complicating concepts were eventually dropped from the model; however, they did play an important part in its evolution given the observed tendency of most people to be unable to focus on the truly important macro

concepts without first gaining an understanding of the micro-components being modeled.

The use of the evolving, complicated graphical conceptual models as interview tools was very helpful because they were an effective means of portraying the purpose of the research effort and in communicating a large amount of complicated and conceptually difficult information. The diagrams, however, tended to be too complicated in the view of the respondents, often requiring significant study by the respondents and explanation by the modeler for them to be judged useful. The graphical models tended to focus the comments of those respondents willing to study them carefully on a few specific relationships rather than on the macro issues, resulting in very complex but probably quite valid conceptual models. The respondents did not add or delete concepts when criticizing the graphical models which might indicate that they interpreted the models to coincide with a personal model.

It was only after the modeler began the process of parameterizing the conceptual models that attention was refocused on the overall macro system. This return to a focus on the macro issues was aided more by the advice of experienced modelers during the research review process rather than by the interview process or literature review. It is important that the parametric modeling process did result in revised conceptual models which were then validated using the same interview respondents. This iterative process in model development is well recognized (Randers 1980, Stenberg 1980).

The interview process, like the literature search, did provide information and feedback concerning model validity and model content but it did not provide much direction for the research. Respondents tended to react specifically to what was presented, rather than providing an appraisal of how the proposed models match with the stated research goals. To the interview respondents, the models represented the research. It is up to the researcher to use other aids in keeping the research on track. In this respect it is almost a prerequisite for any modeler to have someone who is an experienced modeler to evaluate the direction and scope of the research. This person must be willing to follow the research closely as a reviewer or as a research partner.

The end result is that the modeling process mostly is influenced by the ability of the researcher to collect, analyze and interpret large amounts of information about a subject in a framework of his or her own design. The interview process was very much a source of valuable, timely, and rich information, which was very useful in model validation, but it was only that. The interview process did not guide the model development process, nor did it directly result in any conceptual model advancements. The information from the interviews had to be combined with all the other available information before it was useful.

The evolution of the conceptual models and the role which the interviews played can perhaps best be illustrated by analyzing the development of one of the conceptual sector models. The threat sector model was chosen because it

was perhaps the most dynamic of the sector models. The initial threat sector model, shown in Figure 119, was developed prior to the first interviews and was based primarily on the Clark (1986) model of the arms transfer process and literature dealing with United States' defense policies regarding the Soviet Union (Fallows 1981, Luttwak 1984, Reichart and Sturm 1982).

The initial model was based upon the notion that a level of global tension exists which impacts and is impacted by Soviet and United States political and military decisions. The relationship between global tension, the superpower's political actions and the perceived military capabilities were all included the most recent conceptual model although some variable names and specific concepts changed. The basic structure which formed the basis for the sector was that the Soviet threat interacting with the United States created a global tension which placed a demand for United States military capability. This structure did not change but the supporting concepts did and some concepts were discarded after determining that they did not support this general structure specifically. Perhaps the most obvious failing of the initial model, shown in Figure 120, is the fact that so many of the concepts included are ambiguous, e.g. "Policy Objectives Requirements", "Policy Objectives Attainment", the relationship between "Bilateral Demands for Arms Reduction" and "Policy Objectives Requirements", and the relationship between "Desire to Reduce Tension" and "Desire for Arms Reduction."

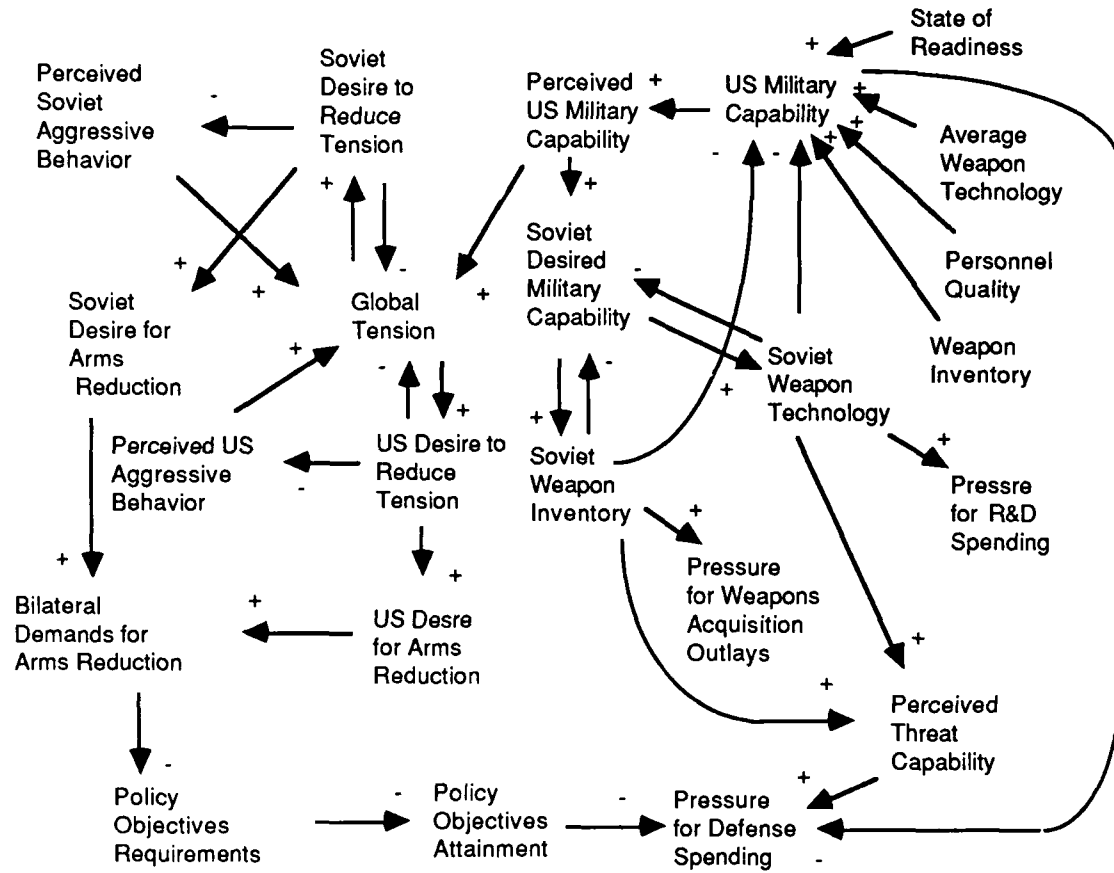

Figure 120. Version 1 of the Threat Sector Model

The second iteration of the threat sector model, shown in Figure 121 indicates a much simpler structure (17 vs 23 concepts and 28 vs 34 relationships). The struggle for a parsimonious model had begun. Basically, ill-defined relationships and concepts were deleted and a relationship between "economic well-being" and Soviet defense expenditures was added (primarily to bring a symmetry to the model's structure). Just as the national sector was used to place the fiscal constraint on the United States' defense expenditures it was determined that similar pressures must be modeled to limit Soviet defense spending growth.

The assorted political policy variables included in the first model were replaced by the more macro concept of "desire to reduce tension." This was done in an effort to maintain simplicity and clarity. Since the model was based on the concept of managing global tension, the political policy variables must relate to that structure as well. The impact of perceived military capabilities on global tension also was deleted at this iteration and replaced by the concept of military capability differential. This reflected that the conceptual models were being developed with the purpose of developing a parametric model and the difference between two variables is easily modeled and reflects some amount of comparison in the decision making process as well. The second iteration of the conceptual model was completed after the first set of interviews and included a relationship which resulted directly from an interview: that between United States technology level and Soviet technology level, which is based on

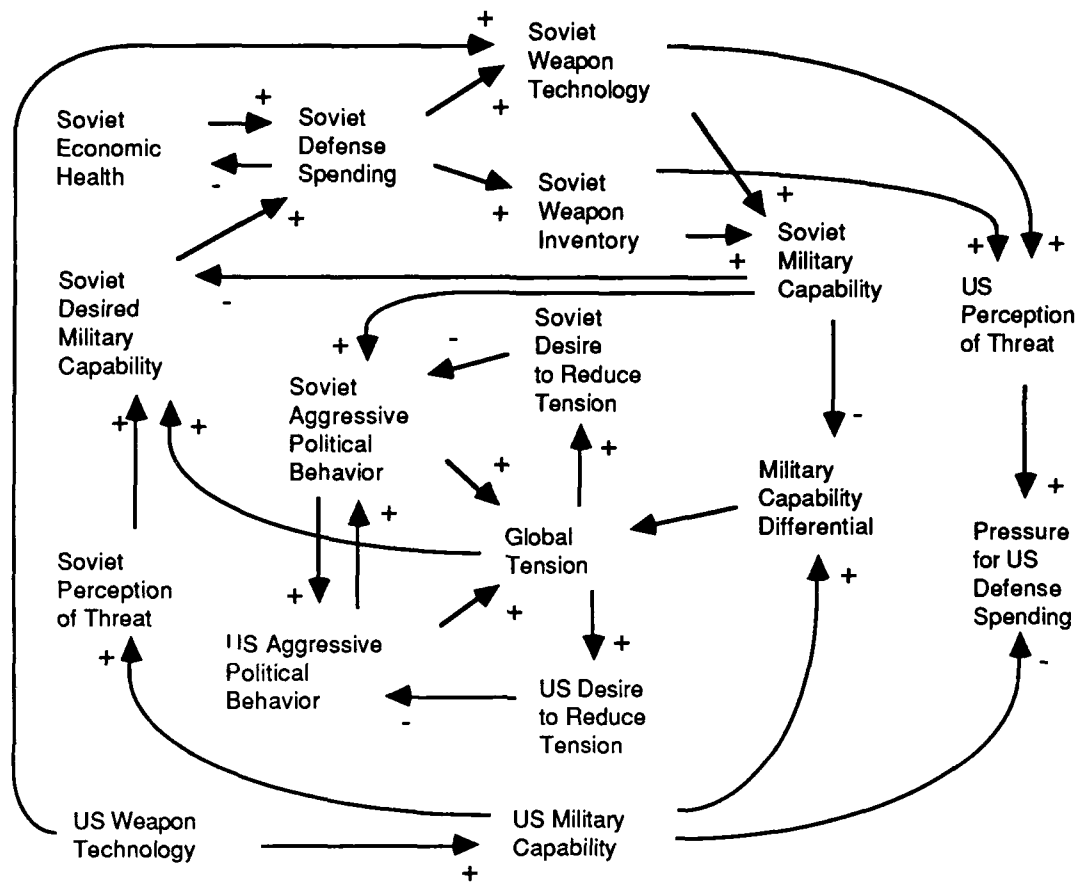

Figure 121. Version 2 of the Threat Sector Model

the transfer of technology from the United States to the Soviet Union.

The third iteration of the model, shown in Figure 122, shows significant changes motivated by the desire to depict a symmetrical structure. While the number of concepts increased in number (from 17 concepts to 24, and from 28 relationships to 47) it was thought that the additions resulted in a more useful model. It was concluded that size was necessary to incorporate important concepts and that this should take precedence over the quest for a parsimonious model just for the sake of smallness. Much of the changes were implemented in order to depict a system structure that is basically symmetrical for the Soviet Union and the United States. Not much is known of the details of Soviet policy making but at this very macro level it was assumed that the decision process is very similar to the one depicted for the United States. Soviet military capability was decomposed to exactly mirror that of the United States. In addition, the concept of military capability differential and perceived military capabilities were replaced by perceived military capability differential from each country's perspective. These changes resulted from the review of the research by independent scholars, some of whom were familiar with the system and some of whom were not. None of these rather significant changes was proposed during the interview process. When these changes were reviewed during interviews they were found to have validity just as the preceding model formulations did. It is not that the previous relationships were wrong but rather they did not relate as well to the overall macro policy orientation of the research.

The next important concept which was added to the model also resulted directly from interaction between the modeling partners. The addition of intelligence resolution during the third iteration and its direct effects on global tension and perceived military capabilities in the final iteration of the model was thought to add significantly to the model's usefulness and validity. After all, it is the uncertainty which exists concerning threat capabilities which tends to drive the escalating nature of the arms race.

A major difference between the third and fourth iteration of this model, shown in Figures 122 and 123 respectively, was that the complexity was much reduced in the final model by aggregating variables and concentrating only on the key conceptual issues. Much of the detail that was omitted was retained in the parametric model. This simplified presentation was a direct result of the comments from the interview respondents. The fourth iteration of the model indicates a symmetric structure and includes the most important concepts which must be represented by the threat sector, that is the basic arms race structure and the interaction between military, political and fiscal constraints. The final iteration of the conceptual model includes 13 concepts and 27 relationships which is about half the size and complexity of the third iteration and more clearly represents the role of threat interaction with the weapon acquisition process. The final iteration of the model focused the attention of the reviewers on the macro issues and away from the detailed relationships.

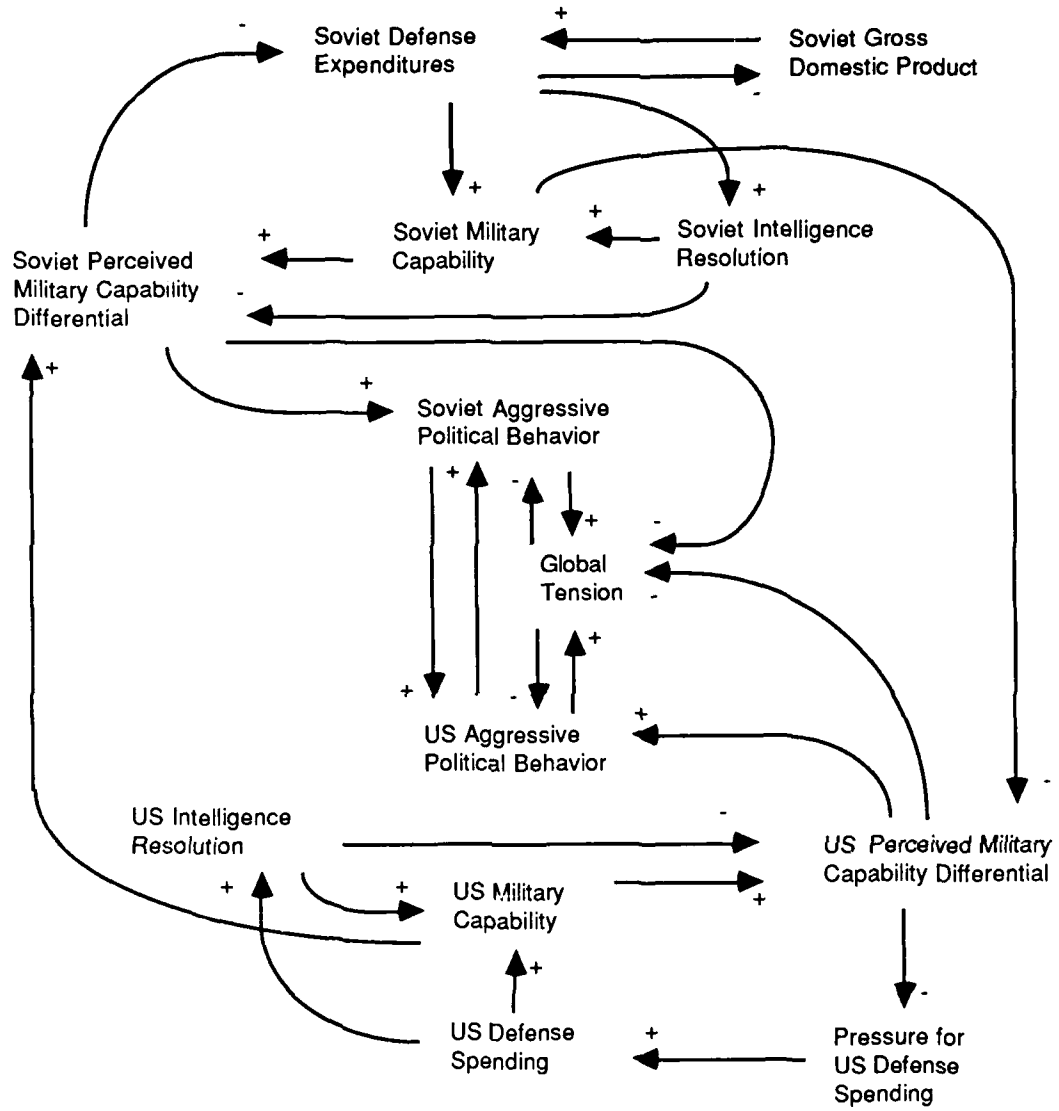

Figure 123. Version 4 of the Threat Sector Model

The major influence of the interviews on the evolving systems models was the conclusion that for the models to be useful as a policy analysis aid they must be relatively parsimonious. This is related to the observation that the interview respondents did not deal with complexity very well and that too much model complexity detracts from the more macro issues which are central to this research. The second most important influence of the interviews was the validation of the research goal, that is a macro level model, and validation of the relationships embodied in the conceptual models. It might seem that it would also be useful to have the interviewees respond to the more detailed conceptual models which relate more closely to the parametric models. However, it is the macro concepts which need to be given the most scrutiny, the more complex relationships which relate to these concepts are more easily found when a strong conceptual framework has been built.

Recommendations

This section of the appendix will be used to identify certain recommended practices for use in conducting interviews in support of system modeling studies. Recommendations which have general applicability to interviewing will be covered in this section. Some recommendations, which are fairly specific in nature, were mentioned in previous sections and will not be expanded upon here.

The use of interview data for the purposes of system modeling and

model validation is almost a requirement when dealing with any system which is impacted significantly by human involvement. A firm foundation in the associated literature is required for the researcher so that previous work can be incorporated into the current study but also as a basis for developing initial conceptual models which will guide the interview process. If the interview process is used to gather basic facts rather than to flesh out a skeleton model it will take much longer and will necessarily be that much harder to manage. Interviews and the data that they provide will be much more useful if the interviewer is well read in the topic area in general and in the area of expertise of the interviewee specifically. The interviews should not be used as a way to *learn about the basic structures* of the system under study, but rather as a way to learn more about the different perspectives which are used in dealing with the system and to learn about the specific causal forces which participants in the system perceive as important.

In any case, the objectives of the interviews must be understood ahead of time and more than one set of interviews will be required to meet the multiple interviewing goals. The interview process described in this appendix is an iterative one. The purpose of the first round of interviews should include the basic goals of identifying useful information sources, cultivating working relationships which will be useful in latter stages of model development, and further refining the purpose and scope of the research project. Not only is the interview process iterative, it will likely be a dynamic process as well. The

results of each interview most likely will influence the conduct of future interviews, so it is very helpful to take notes concerning the substance of the interview as well as notes concerning possible improvements to the interview procedure. These notes may be useful in determining how future interviews can be structured to gain the information that is being sought.

During the initial interviews when respondents were responding to broad questions, it was quite common for the conversation to drift away from pertinent topics. A list of very specific questions was necessary to be able to get the interview back on track at these times. In addition it is quite important to introduce the goals of the research and the role of the interviews in meeting these goals.

The selection of interview respondents should also be considered as a dynamic process in which each interviewee is seen as a possible link to a new source of data. It is most probable that whatever list is made prior to starting the interview process will be revised as sources become unavailable and new sources are discovered. In fact all interviews should include the identification of additional data sources as an objective.

A broad mix of views and perspectives is required from the respondents of the interviews and this requires not only broad organizational perspectives but also broad temporal perspectives. In many cases, the respondents who were no longer involved in the day-to-day management of the system provided the best long-term perspective, although the views of those currently involved

are essential because it is the divergence between long and short term perspectives that provides useful insights into key system structures and behaviors.

The use of a voice recorder is certainly the best method of documenting an interview. If however, the nature of the subject matter and the position of the interviewee is such that a voice recorder would inhibit the interview process, a workable alternative is to take detailed notes during the interview, go over the notes with the subject to fill in any holes or to make any necessary clarifications, and then transcribe the notes into a complete set of detailed notes immediately following the interview. The key here is to immediately perform the transcription because the information gained in the interview is lost quickly. Many, if not most important details may be forgotten if too much time passes before the notes are transcribed.

An interview guide which outlines the purpose of the interview and specific interview questions is mandatory for the interviewer to be able to steer the interview in the desired direction. The interview questions should not be read to the respondent as this may produce an undesirable question/short answer form of interaction. If the first question is sufficiently broad, it may lead to a discussion which answers the rest of the questions without them having to be asked. Such a free-flowing interview is much richer, especially early in the interview process, than a structured interview where the respondent responds to specific questions. Some interview time must be spent describing and

selling the research which the interview is supporting. This is important for setting the tone of the interview as it enables a respondent to tailor his or her responses based on the researcher's goals. It is also an important step in building a rapport with respondents such that they may become willing to provide contacts and future help.

The evolution of the conceptual graphical models is one in which there is an ongoing tradeoff between the model's size and the model's clarity. In general it was found that smaller, less complex models were more readily understood, however, it was the more complex models which paved the way for including all of the important concepts. In retrospect it seems that including important concepts must take priority over the goal of developing a parsimonious model in the absolute sense. That is parsimony is a relative term. On the other hand a parsimonious model which is able to include all of the important concepts is a very important goal and the role of parsimony in making a model useful and understandable should not be minimized or used as an excuse for overly complex and cumbersome models. A summary of these recommendations is presented in Table 17.

Table 17. -- Summary of Recommendations

**Conceptual Model Formulation and
the Interview Process**

	Pre-Interview Process	Round One Interviews	Post Interview Process
Objectives	<p>Develop list of sources Develop initial conceptual models Develop an interview format and content which will elicit the information which is desired</p>	<p>Introduce research goals Develop working relationships Determine interviewee's personal conceptual model Get the interviewee's reaction to the initial conceptual models</p>	<p>Refine conceptual models Review round one interviews substance and format Produce a paper which describes the research and the emerging conceptual models Identify the most useful sources of information</p>
Activities	<p>In-depth review of the pertinent literature Causal modeling Develop list of possible sources Contact possible sources to schedule interviews</p>	<p>Take notes or record the interview Introduce the research problem quickly but completely Transcribe notes following interview</p>	<p>Further review of the pertinent literature Causal modeling Identify those sources to review the conceptual framework paper Develop a new interview guide for second round which focuses on holes from first round</p>
Conclusions	<p>Initial review of the literature should be significant Initial causal models should focus on macro concepts Have a list of specific questions to ask Use causal models to indicate scope of the research</p>	<p>Emphasize the goals of the research Indicate the role of the interviews in the research process Identify additional sources Use a tape recorder if it is possible Transcribe notes immediately following the interview</p>	<p>The scope of the pertinent literature will Stress simplicity and clarity in the causal models Reviewers should represent a broad spectrum of opinions and backgrounds Interviews should stress validation of the conceptual models</p>

Table 17. -- Summary of Recommendations Continued

Conceptual Model Formulation and the Interview Process		
	Round Two Interviews	Post Interview Process
Objectives	Develop policy alternatives Validation of broad research goals, macro level concepts and individual causal relationships which are modeled Identify additional sources of information and validation	Refine the conceptual models to include the information from the interviews and literature which correspond to the research goals Develop a critique of the interview process and characterize the information which has been collected
Activities	Discuss respondent's response to the conceptual paper Ask for additional sources of information Ask for specific policy alternatives to deal with the system behaviors which are characterized as problems	Causal modeling Write a final draft of conceptual paper
Conclusions	Request written comments on the paper which is reviewed Attempt to focus the respondents attention on macro issues, as they are more important than individual relationships Write the paper for review around the macro concepts, limiting the amount of detail to that necessary to clarify these issues	Use top-down modeling approach, stressing macro concepts Interview data is timely, but respondents involved in the system have difficulty viewing the system from the macro perspective The more work put into the conceptual modeling phase the easier the parametric modeling phase will be

APPENDIX B

DYNAMO CODE FOR PARAMETRIC MODEL

Note *** Version 1.0 Integrated Weapon Acquisition Model ***

Note *** 25 May 1988 ***

Note

Note The baseline year for this sector is 1960, all dollar amounts are in

Note 1960 constant year billions of dollars.

Note

Note *** Threat Sector ***

Note

TA1 A $SDE.K = SDSGDP.K * SGDP.K$
 Note Soviet Defense Expenditures (\$ billion/year)

TL1 L $SDSGDP.K = SDSGDP.J + (DT * SDSRC.JK)$
 N $SDSGDP = .09$

Note Soviet Defense Share of Gross Domestic Product (%).

TR1 R $SDSRC.KL = SDSGDP.K * SPCEDS.K * (.17 - SDSGDP.K)$

Note Soviet Defense Share Rate of Change (%/year).

TA2 A $SPCEDS = TABHL(TSDS, SPMCD.K, -200, 200, 100)$

TT1 T $TSDS = 1, .25, 0, -.12, -.6$

Note Soviet Perceived Capability Effect on Defense Share

Note (% change/year).

TL2 L $SGDP.K = SGDP.J + (DT * SGDPRC.JK)$

N $SGDP = 215$

Note Soviet Gross Domestic Product (\$ billion/year).

TR2 R $SGDPRC.KL = SGDP.K * SGDPI.K / 3$

Note Soviet GDP Rate of Change (\$ billion/year/year).

TA3 A $SGDPI.K = TABHL(TSGDP, SDE.J / SGDP.J, .09, .15, .01)$

TT2 T $TSGDP = .35, .034, .031, .026, .023, .021, .02$

Note Soviet GDP Increase (%).

TL3 L $SRED.K = SRED.J + (DT * SRRC.JK)$

N $SRED = 15$

Note Soviet Military Readiness Level (\$ billion).

TR3 R $SRRC.KL = (SRSE * SRSS * SDE.K) - (SRED.K / SRDR)$

Note Soviet Readiness Rate of Change (\$ billion/year)

C $SRSE = .4$

Note Soviet Readiness Spending Efficiency (%).

C $SRDR = 2$

- Note Soviet Readiness Depletion Rate (years).
 TA4 A $SRSS.K=1-SWISS.K-SWTSS.K-SISS.K$
 Note Soviet Readiness Spending Share (%).
 TL4 L $SWPN.K=SWPN.J+(DT*SWIR.JK)$
 N $SWPN=100$
 Note Soviet Weapon Inventory (\$ billion).
 TR4 R $SWIRC.KL=SPE*SWE.K-SWPN.K/SWDR.K$
 Note Soviet Weapon Inventory Rate of Change (\$ billion/year).
 C $SPE=.6$
 Note Soviet Production Efficiency (%).
 TA5 A $SWE.K=SWISS.K*SDE.K$
 Note Soviet Weapon Expenditures (\$ billion/year).
 TA6 A $SWDR.K=TABHL(TSWD,GT.K,0,100,20)$
 TT3 T $TSWD=50,30,25,20,10,.5$
 Note Soviet Weapon Depletion Rate (\$ billion/year).
 TA7 A $SWISS=TABHL(TSWS,SWPN.K/(SIAC.K*WPNIN.K),0,2,.5)$
 TT4 T $TSWS=.5,.41,.37,.34,.3$
 Note Soviet Weapon Inventory Spending Share (%).
 TL5 L $SWTK.K=SWTK.J+(DT*SWTRC.JK)$
 N $SWTK=6$
 Note Soviet Weapon Technology (\$ billion).
 TR5 R $SWTRC.KL=STE*SWTSS*SDE.K-SWTK.K/SWTDR.K$
 Note Soviet Weapon Technology Rate of Change (\$ billion/year).
 C $STE=.6$
 Note Soviet Technology Efficiency (%).
 TA8 A $SWTSS=TABHL(TSWTS,SWTK.K/(SIAC.K*WPNTK.K),0,2,.5)$
 TT5 T $TSWTS=.15,.11,.08,.06,.05$
 Note Soviet Weapon Technology Spending Share (%).
 TA9 A $SWTDR.K=TABHL(TSTDR,SWTK.K/WPNTK.K,0,2,.5)$
 TT6 T $TSTDR=3,3.7,4,4.3,5$
 Note Soviet Weapon Technology Depletion Rate (years).
 TL6 L $SINR.K=SINR.J+(DT*SINRR.JK)$
 N $SINR=9$
 Note Soviet Intelligence Resolution (\$ billion).
 TR6 R $SIRRC.KL=(SISE*SISS.K*SDE.K)-(SINR.K/SIDR.K)$
 Note Soviet Intelligence Resolution Rate of Change (\$ billion/year).
 C $SISE=.7$
 Note Soviet Intelligence Spending Efficiency (%).
 TA10 A $SISS.K=TABHL(TSIS,SINR.K/INRES.K,0,2,.5)$
 TT7 T $TSIS=.12,.105,.1,.095,.08$
 Note Soviet Intelligence Spending Share (%).
 TA11 A $SIDR.K=TABHL(TSID,SINR.K/INRES.K,0,2,.5)$
 TT8 T $TSID=2,2.7,3,3.3,4$
 Note Soviet Intelligence Depletion Rate (years).

- TA12 A $SIAC.K=1+SBIAS*SAMP.K$
 Note Soviet Intelligence Accuracy Multiplier.
 C $SBIAS=.1$
 Note Soviet intelligence bias (% overestimation).
- TA13 A $SAMP.K=TABHL(TSIAC,SINR.K/INRES.K,0,2,.5)$
 TT9 T $TSIAC=2,1.3,1,.9,.85$
 Note Soviet intelligence accuracy Amplifier.
- TA14 A $SPMCD.K=(SRE.K+SWIE.K+SWTE.K+SIE.K)*SGTE.K$
 Note Soviet Perception of Military Capability Difference (\$ billion).
- TA15 A $SGTE.K=TABHL(TSCD,GT.K,0,100,25)$
 TT10 T $TSCD=1.2,1.05,1,.95,.9$
 Note Soviet Global Tension Effect on SPMCD (dimensionless).
- TA16 A $SRE.K=SRED.K-(RED.K*SIAC.K)$
 Note Soviet readiness effect (\$ billion/Global Tension Unit).
- TA17 A $SWIE.K=SWTK.K-(WPNTK.K*SIAC.K)$
 Note Soviet weapon inventory effect (\$ billion/ Global Tension Unit).
- TA18 A $SWTE.K=SWTK.K-(WPNTK.K*SIAC.K)$
 Note Soviet weapon technology effect (\$ billion/Global Tension Unit).
- TA19 A $SIE.K=SINR.K-(INRES.K*SIAC.K)$
 Note Soviet intelligence effect (\$ billion).
- TL7 L $SDT.K=SDT.J+(DT*SDTRC.JK)$
 N $SDT=50$
 Note Soviet Desired Tension Level (Global Tension Units).
- TR7 R $SDTRC.KL=GT.K*TABHL(TSDT,SPMCD.K,-200,200,100)$
 TT11 T $TSDT=-.02,-.005,0,.005,.02$
 Note Soviet Desired Threat Rate of Change
 Note (Global Tension Units/year).
- TL8 L $GT.K=GT.J+(DT*GTRC.JK)$
 N $GT=50$
 Note Global Tension (GTUs).
- TR8 R $GTRC.KL=((SPCE.K+USPCE.K+SDTE.K+USDTE.K)*INE.K*GT.K)+VNE.K$
 Note Global threat rate of change (GTUs/year).
- TA20 A $SPCE.K=TABHL(TSPC, SPMCD.K,-200,200,100)$
 TT12 T $TSPC=.1,.02,0,-.02,-.1$
 Note Soviet Perceived military Capability Differential Effect on Global
 Note Tension (% change/year).
- TA21 A $USPCE=TABHL(TUSPC, PMCD.K,-200,200,100)$
 TT13 T $TUSPC=.1,.02,0,-.02,-.1$
 Note US Perceived military Capability Differential Effect on Global
 Note Tension (% change/year).
- TA22 A $SDTE.K=(SDT.K-GT.K)/(GT.K*3)$
 Note Soviet Political Behavior Effect on Global Tension
 Note (% change/year).

- TA23 A $USDT.E.K=(USDT.K-GT.K)/(GT.K^2)$
 Note US Desired Threat Effect on Global Tension (% change/year).
- TA24 A $INE.K=TABLE(TINE, USIAC.K*SIAC.K, 1, 1.5, .1)$
- TT14 T $TINE=1, 1.02, 1.1, 1.15, 1.18, 1.2$
 Note Intelligence Effect on Global Tension (multiplier).
- TL9 L $USDT.K=USDT.J+(DT*USDTRC.JK)$
 N $USDT=50$
 Note US Desired Tension Level (GTUs).
- TR9 R $USDTRC=GT.K*TABHL(TUSDT, PMCD.K, -200, 200, 100)$
- TT15 T $TUSDT=-.02, -.005, 0, .005, .02$
 Note US Desired Threat Rate of Change (GTUs/year).
- TA25 A $PMCD.K=(RE.K+WIE.K+WTE.K+IRE.K-PACDF)*GTE.K$
 Note US Perceived Military Capability Differential (\$ billion).
- TA26 A $GTE.K=TABHL(TCD, GT.K, 0, 100, 25)$
- TT16 T $TCD=1.2, 1.05, 1, .95, .9$
- TA27 A $RE.K=RED.K-SRED.K*USIAC.K$
 Note US Readiness Effect on perceived military capability differential.
- TA28 A $WIE.K=WPIN.K-SWPN.K*USIAC.K$
 Note US Weapon Inventory Effect on perceived military capability differential.
- TA29 A $WTE.K=WPNTK.K-SWTK.K*USIAC.K$
 Note US Weapon Technology Effect on perceived military capability differential.
- TA30 A $IRE.K=INRES.K-SINR.K*USIAC.K$
 Note US Intelligence Effect on perceived military capability differential.
- TA31 A $VNE.K=20*(RAMP(.4,5)-RAMP(.4,8)-RAMP(.4,9)+RAMP(.4,12))$
 Note Viet Nam Effect on Global Tension (GTUs/year).
 Note
 Note *** National Sector ***
 Note
- NA1 A $GNP.K=CON.K+INV.K+(SSPL.K+DSPL.K)$
 Note Gross National Product (\$ billion/year).
- NA2 A $CON.K=PC.K*SINC.K$
 Note Consumption (\$ billion/year).
- NA3 A $PC.K=PCC*REPC.K$
 Note Propensity to Consume (\$ consumption/\$ income).
 C $PCC=.8$
 Note Initial Propensity to Consume.
- NA4 A $REPC.K=TABHL(TREPC, R.K, 0, .1, .02)$
- NT1 T $TREPC=1.01, 1.003, 1, .999, .996, .99$
 Note Interest Rate effect on propensity to consume.
- NL1 L $SINC.K=SINC.J+((DT/TSI)*(GNP.J-SINC.J))$
 N $SINC=482$

- Note Smoothed Income (\$ billion/year).
C TSI=2
- Note Time to Smooth Income (years).
- NA5 A $INV.K=LIGR*SINC.K*(2+SIN(6.283*TIME.K/IPER))$
Note Net Investment (\$ billion/year).
C IPER=15
Note Long-run Investment cycle Period (years).
C LIGR=.04
- Note Long-run Investment Growth Rate (% change/year).
- NL2 L $CAP.K=CAP.J+(DT*INV.J)$
N CAP=1100
Note Capital Stock (\$ billion).
- NA6 A $FSPL.K=SSPL.K+DSPL.K+DETSRV.K$
Note Federal Spending Level (\$ billion/year).
- NL3 L $SSPL.K=SSPL.J+(DT*SSPLRC.JK)$
N SSPL=37
Note Social Spending Level (\$ billion/year).
- NR3 R $SSPLRC.KL=SSPL.K*DESS.K/2$
Note Social Spending Level Rate of Change (\$ billion/year/year).
- NA7 A $DESS.K=TABLE(TSS,SDEF.K/GNP.K,-.05,.05,.025)$
NT2 T TSS=.12,.09,.07,.06,.055
Note Deficit Effect on Social Spending.
- NA8 A $DETSRV.K=NDET.J*R.K$
Note Debt Service (\$ billion/year).
- NL4 L $R.K=R.J+(DT*RRC.JK)$
N R=.05
Note Interest Rate (APR).
- NR4 A $RRC.JK=R.K*TABHL(TR,BOR.K/SAV.K,0,1,.2)$
NT3 T TR=-.06,-.03,-.01,0,.02,.1
Note Interest Rate rate of change (%change/year).
- NA9 A $SAV.K=GNP.K-CON.K$
Note Annual Savings (\$ billion).
- NA10 A $BOR.K=INV.K+DEF.K$
Note Annual Borrowing (\$ billion).
- NL5 L $NDET.K=NDET.J+(DT*DEF.K)$
N NDET=138
Note National Debt (\$ billion).
- NA11 A $DEF.K=FSPL.K-REV.K$
Note Federal Spending Deficit (\$ billion/year).
- NA12 A $SDEF.K=DLINF3(DEF.K,2)$
Note Smoothed Deficit (\$ billion).
- NA13 A $REV.K=TAXR.K*GNP.K$
Note Revenues (\$/year).
- NL6 L $TAXR.K=TAXR.J+(DT*TAXRRC.JK)$

- N TAXR=.18
 Note Tax Rate (% of aggregate income).
- NR6 R TAXRRC.KL=TAXR.K*DETR.K
 Note Tax Rate Rate of Change (APR/year).
- NA14 A DETR.K=DLINF3(TABLE(TDT,DEF.K/GNP.K,-.05,.05,.025),3)
 NT4 T TDT=-.2,-.1,0,.005,.02
 Note Deficit Effect on Tax Rates (% change/year).
- NL7 L DSPL.K=DSPL.J+(DT*DSLRC.JK)
 N DSPL=41
 Note Defense Budget (\$ billion/year).
- NR7 R DSLRC.KL=DSPL.K*(DEDS.K+GTEDS.K+PCDEDS.K+EEAB.K)
 Note Defense Spending Level Rate of Change (\$ billion/year/year).
- NA15 A DEDS.K=DLINF3(TABHL(TDD,SDEF.K/GNP.K,-.05,.05,.025),3)
 NT5 T TDD=.02,.002,0,-.025,-.07
 Note Deficit Effect on Defense Spending Level (% change/year).
- NA 16 A GTEDS.K=TABHL(TGTDS,GT.K-DLINF3(GT.K,1),-10,10,4)
 NT6 T TGTDS=-.04,-.02,-.01,.01,.08,.1
 Note Global Tension Effect on Defense Spending (% change).
- NA17 A PCDEDS.K=TABHL(TPCDDS,PMCD.K,-100,100,50)
 NT7 T TPCDDS=.03,.028,.02,.005,0
 Note Perceived Capability Differential Effect on Defense Spending
 Note (% change/year).
- NA18 A EEAB.K=DLINF3((STEP(.07,17)+STEP(.13,18)-STEP(.2,21)),2)
 Note Early Eighties Arms Build-up (% change/year).
 Note
 Note *** Defense Sector ***
 Note
- DL1 L WPNIN.K=WPNIN.J+(DT*WIRC.JK)
 N WPNIN=175
 Note US Weapon Inventory (\$ billion).
- DR1 R WIRC.KL=(PROR.K*SIP.K*UCST.K)*WPNTM.K-
 (WPNIN.K/USWDR.K)
 Note Weapon Inventory Rate of Change (\$ billion/year).
- DA1 A WPNTM.K=TABHL(TWTM,WPNTK.K/SWTK.K,0,2,.5)
 DT1 T TWTM=.8,.95,1,1.03,1.05
 Note Weapon Technology Multiplier (dimensionless).
- DA2 A USWDR.K=TABHL(TWDR,(TRAF.K+GT.K)*FMM.K,0,100,20)
 DT2 T TWDR=50,30,25,20,10,.5
 Note US Weapon Depletion Rate (years).
- DA3 A TRAF.K=TABHL(TTRAF,TRA.K/DSPL.K,0,.3,.05)
 DT3 T TTRAF=-5,-1,0,.5,1,2,4
 Note Training Factor (Global Tension Units).
- DA4 A FMM.K=TABLE(TFMM,FM.K,0,1,.2)
 DT4 T TFMM=2,1.8,1.2,1.05,.95,.9

- Note Force Maintaiability Multipler (dimensionless).
- DA5 A $WASL.K = WASS.K * DSPL.K$
Note Weapon Acquisition Spending Level (\$ billion/year).
- DA6 A $WASS.K = TABHL(TWASS, WPNIN.K / (USIAC.K * SWPN.K), 0, 2, .5)$
DT5 T $TWASS = .35, .33, .29, .26, .24$
Note Weapon Acquisition Spending Share (%).
- DL2 L $SID.K = SID.J + (DT * SIDRC.JK)$
N $SID = 24$
Note Systems In Development (systems).
- DR2 $SIDRC.KL = (DST.K - DCR.K - DCNX.K) * ((1 - SID.K) / SID.K)$
Note Systems in Development Rate of Change (Systems/year)
- DA7 A $DST.K = DSP * WASL.K / (DCST.K / SDP.K)$
Note Development Starts (systems/year).
C $DSP = .08$
Note Development Starts Proportion of WASL (%).
- DA8 A $DCR.K = SID.K / SDP.K$
Note Development Completion Rate (systems/year).
- DA9 A $SDP.K = WTKE.K * DCSTE.K$
Note System Development Period (years).
- DA10 A $WTKE.K = TABHL(TWTKE, TKPRO.K / TKAV.K, 0, 1, .2)$
DT6 T $TWTKE = 3.5, 3.8, 4, 4.05, 4.2, 4.6$
Note Weapon Technology Effect on system development period
Note (years).
- DA11 A $DCSTE.K = .5 + ((DCST.K / WASL.K) * 12)$
Note Development Cost Effect on system development period
Note (dimensionless).
- DA12 A $DCNX.K = SID.K * DCNXR.K$
Note Development Cancellations (systems/year).
- DA13 A $DCNXR = TABHL(TDCR, SAFF.K, 0, 10, 2)$
DT7 T $TDCR = 0, .07, .1, .12, .13, .135$
Note Development Cancellation Rate (%/year).
- DL3 L $SAFF.K = SAFF.J + (DT * SAFPRC.JK)$
N $SAFF = 5$
Note Systems Available For Production (systems).
- DR3 R $SAFPRC.KL = DCR.K - DSOR.K - PST.K$
Note Systems Available for Production Rate of Change (systems).
- DA14 A $DSOR.K = SAFF.K / DSDR$
Note Developed Systems Obsolesence Rate (systems/year).
C $DSDR = 4$
Note Developed Systems Depreciation Rate (years).
- DA15 A $PST.K = MIN(DPST.K, SAFF.K)$
Note Production Starts (systems/year).
- DA16 A $DPST.K = TABHL(TDPST, UPS.K, 0, 300, 50) * (DSPP / SPP.K)$
DT8 T $TDPST = .2, 1, 2, 2.6, 3, 3.3, 3.5$

- Note Desired Production Starts (systems/year).
C DSPP=5
- DA17 Note Desired System Production Period (years).
A $PFND.K = WASL.K - GINV.K - (SID.K * DCST.K / SDP.K)$
- DL4 Note Production Funds (\$ billion/year).
L $DCST.K = DCST.J + (DT * DCRC.JK)$
N DCST=.4
- DR4 Note Development Cost (\$ billion/system).
R $DCRC.KL = (TKE.K + UCSTE.K) * DCST.K$
Note Development Cost Rate of Change (\$ billion/system/year).
- DA18 A $TKE.K = TABHL(TTKE, TKPRO, KTKAV, K, 0, 1, .2)$
DT9 T $TTKE = -.04, -.02, -.005, 0, .01, .04$
- DA19 Note Technology Effect on development costs (% change).
A $UCSTE.K = TABHL(TUCSTE, UCST.K / DCST.K, 0, 3.5, .5)$
DT10 T $TUCSTE = 0, .03, .05, .06, .065, .0675, .069, .07$
- DL5 Note Unit Cost Effect on development cost (% change).
L $SIP.K = SIP.J + (DT * SIPRC.JK)$
N SIP=17
- DR5 Note Systems In Production (systems).
R $SIPRC.KL = (PST.K - PCNX.K - PCOM.K) * ((SIP.K - 1) / SIP.K)$
Note Systems in Production Rate of Change (systems/year).
- DA20 A $PCNX.K = SIP.K * PCR$
Note Production Cancellations (systems/year).
C PCR=0
- DA21 Note Production Cancellation Rate (% systems cancelled each year).
A $PCOM.K = SIP.K / SPP.K$
Note Production Completion rate (systems/year).
- DA22 A $SPP.K = UPS.K / PROR.K$
Note System Production Period (years).
- DA23 A $PROR.K = \min(CAPL.K, FEPR.K)$
Note Production Rate (units/system/year).
- DA24 A $FEPR.K = PFND.K / (SIP.K * UCST.K)$
Note Funding Effect on Production Rate (units/system/year).
- DA25 A $CAPL.K = (ICAP.K - FMS.K) / (PRCST.K * SIP.K)$
Note Capacity Limitation on production rate (units/system/year).
- DL6 L $UPS.K = UPS.J + (DT * UPSRC.JK)$
N UPS=265
- DR6 Note Units Produced per System (units/system).
R $UPSRC.KL = (SPPE.K + FNDE.K) * (UPS.K - 1)$
Note Units per System Rate of Change (units/system/year).
- DA26 A $FNDE.K = (UPSF.K - SUPS.K) / (5 * SUPSF.K)$
Note Funding Effect on UPS (% change/year).
- DA27 A $UPSF.K = PFND.K / (SIP.K * UCST.K)$
Note Units Per System Factor (dimensionless).

- DA28 A $SUPSF.K = DLINF3(UPS.F.K, 3)$
 Note Smoothed Units Per System Factor (dimensionless).
- DA29 A $SPPE.K = TABHL(TSPP, SPP.K, 7.5, 10, .5)$
- DT11 T $TSPP = 0, -.002, -.005, -.01, -.02, -.04$
 Note System Production Period Effect on UPS (% change/year).
- DL6 L $RED.K = RED.J + (DT * REDRC.JK)$
 N $RED = 30$
 Note US Readiness level (\$ billion).
- DR6 R $REDRC.KL = (PQF.K + FMF.K + SMF.K) * RED.K$
 Note Readiness Rate of Change (\$ billion/year).
- DA30 A $PQF.K = TABHL(TPQF, PQ.K - DPQ.K, -3, 3, 1)$
- DT12 T $TPQF = -.3, -.15, -.06, 0, .03, .08, .15$
 Note Personnel Quality Factor (% change/year).
- DA31 A $FMF.K = TABHL(TFMF, FM.K - DFM.K, -.5, .5, .2)$
- DT13 T $TFMF = -.3, -.1, -.01, .01, .03, .08$
 Note Force Maintainability Factor (% change/year).
- DA32 A $SMF.K = TABHL(TSMF, SM.K - DSM.K, -3, 3, 1)$
- DT14 T $TSMF = -.3, -.15, -.06, 0, .03, .08, .15$
 Note Spares and Munitions Factor (% change/year).
- DL7 L $SM.K = SM.J + (DT * SMRC.JK)$
 N $SM = 12$
 Note Spares and Munitions stock level (\$ billion)
- DR7 R $SMRC.KL = SMSL.K - (SM.K / SMDR.K)$
 Note Spares and Munitions Rate of Change (\$ billion/year).
- DA33 A $SMDR.K = TABHL(TSMDR, GT.K + TRAF.K, 0, 100, 25)$
- DT15 T $TSMDR = 10, 4, 2, 1, .5$
 Note Spares and Munitions Depreciation Rate (years).
- DA34 A $SMSL.K = OMSL.K * SMSS.K$
 Note Spares and Munitions Spending Level (\$ billion/year).
- DA35 A $OMSL.K = OMSS.K * DSPL.K$
 Note O&M Spending Level (\$ billion/year).
- DA36 A $OMSS.K = 1 - RDSS.K - WASS.K - IRSS.K$
 Note O&M Spending Share (%).
- DA37 A $SMSS.K = TABHL(TSMSS, DSM.K - SM.K, 0, 5, 1)$
- DT16 T $TSMSS = .22, .25, .27, .28, .287, .29$
 Note Spares and Munitions Spending Share of O&M spending level
 Note (%).
- DA38 A $DSM.K = TABHL(TDSM, GT.K, 0, 100, 25)$
- DT17 T $TDSM = 8, 14, 15, 16, 22$
 Note Desired Spares and Munitions level (\$ billion).
- DL8 L $FM.K = FM.J + (DT * FMRC.JK)$
 N $FM = 8$
 Note Force Maintainability (%).
- DR8 R $FMRC.KL = (SMFM.K + SRFM.K + PQFM.K) * (FM.K - 1)$

- Note Force Maintainability Rate of Change (%/year).
- DA39 A $SMFM.K = TABHL(TSMFM, DSM.K - SM.K, -1, 4, 1)$
- DT18 T $TSMFM = .01, .003, 0, -.003, -.01, -.05$
- Note Spares and Munitions effect on Force Maintainability
- Note (% change).
- DA40 A $SRFM.K = (SYSR.K - FM.K) * (PFND.K / WPNIN.K)$
- Note System Reliability effect on Force Maintainability (% change).
- DA41 A $PQFM.K = TABHL(TPQFM, DPQ.K - PQ.K, -2, 10, 2)$
- DT19 T $TPQFM = .02, .005, 0, -.005, -.02, -.05, -.1$
- Note Personnel Quality effect on Force Maintainability (FM index).
- DA42 A $DFM.K = TABHL(TDFM, GT.K, 0, 100, 25)$
- DT20 T $TDFM = .5, .7, .85, .9, .95$
- Note Desired Force Maintainability (%).
- DL9 L $PQ.K = PQ.J + (DT * PQRC.JK)$
- N $PQ = 11$
- Note Personnel Quality level (\$1000/person).
- DR8 R $PQRC.KL = (WIMP.K + TIMP.K) * PQ.K$
- Note Personnel Quality Rate of Change (\$1000/person/year).
- DA43 A $WIMP.K = TABHL(TWIMP, PSL.K / FS.K, 2, 6, 1)$
- DT21 T $TWIMP = -.03, -.01, 0, .01, .015$
- Note Wage Impact on Military Personnel quality input level
- Note (% change).
- DA44 A $PSL.K = PSS.K * OMSL.K$
- Note Personnel Spending Level (\$ billion).
- DA45 A $PSS.K = TABHL(TPSS, DPQ.K - PQ.K, -3, 3, 1)$
- DT22 T $TPSS = .4, .47, .51, .54, .55, .57, .6$
- Note Personnel Spending Share (% of O&M/P spending level).
- DA46 A $DPQ.K = TABHL(TDPQ, WPNTK.K, 0, 20, 5)$
- DT23 T $TDPQ = 7.5, 8, 9, 11, 15$
- Note Desired Personnel Quality level (\$1000/person).
- DL10 L $FS.K = FS.J + (DT * FSRC.JK)$
- N $FS = 2.5$
- Note Force Size (millions of active duty military personnel).
- DR10 R $FSRC.KL = (DFS.K - FS.K) / 5$
- Note Force Size Rate of Change (millions of persons/year).
- DA47 A $DFS.K = TABHL(TFS, WIS.K, 0, 40000, 10000)$
- DT24 T $TFS = 1.5, 1.6, 1.8, 2.2, 2.8$
- Note Desired Force Size (millions).
- DL11 L $WIS.K = WIS.J + (DT * WISRC.JK)$
- N $WIS = 35000$
- Note Weapon Inventory Size (units).
- DR11 R $WISRC.KL = (PROR.K * SIP.K) - (WIS.K / USWJR.K)$
- Note Weapon Inventory Size Rate of Change (units/year).
- DA48 A $TIMP.K = TABHL(TTIMP, TRA.K / FS.K, 0, 6, 1)$

- DT25 T $TTIMP = -.03, -.015, -.005, 0, .005, .007, .008$
 Note Training Impact on Military Personnel quality (% change).
- DA49 A $TRA.K = TRAS.K * OMSL.K$
 Note Training Level, annual expenditures (\$ billion/year).
- DA50 A $TRAS.K = 1 - PSS.K - SMSS.K$
 Note Training Share of O&M annual expenditures (%).
- DL12 L $WPNTK.K = WPNTK.J + (DT * WTRC.JK)$
 N $WPTNK = 18$
 Note US Weapon Technology level (\$ billion).
- DR12 R $WTRC.K = (TKPRO.K * SYSR.K) - (WPNTK.K / WTDR.K)$
 Note Weapon Technology Rate of Change (\$ billion/ year).
- DA51 A $TKPRO.K = MIN(DTP.K, TKAV.K)$
 Note Technology Produced (\$ billion/year).
- DL13 L $TKAV.K = TKAV.J + (DT * TKAVRC.JK)$
 N $TKAV = 10$
 Note Technology Available (\$ billion).
- DR13 R $TKAVRC.KL = (WLSL.K * LTSE) - (TKAV.J / TRC.J)$
 Note Technology Available Rate of Change (\$ billion/year).
 C $LTSE = .6$
 Note Lethality Spending Efficiency (%).
- DA52 A $TRC.K = TABHL(TTRC, WPNTK.K / SWTK.K, 0, 5, 1)$
- DT26 T $TTRC = 3.5, 4.2, 4.5, 4.7, 4.8, 4.85$
 Note Technological Rate of Change (years).
- DA53 A $RDSL.K = RDSS.K * DSPL.K$
 Note Research and Development Spending Level (\$ billion/year).
- DA54 A $RDSS.K = TABHL(TRDSS, WPNiN.K / (USIAC.K * SWPN.K), 0, 5, 1)$
- DT27 T $TRDSS = .15, .12, .1, .09, .085, .083$
 Note Research and Development Spending Share (%).
- DA55 A $WTDR.K = TABHL(TWTDR, WPNTK.K / SWTK.K, 0, 5, 1)$
- DT28 T $TWTDR = 3.1, 3.8, 4.1, 4.3, 4.7, 5.2$
 Note Weapon Technology Depletion Rate (years).
- DL14 L $SYSR.K = SYSR.J + (DT * SYSRRC.JK)$
 N $SYSRC = .7$
 Note System Reliability (OR rate) of new weapon systems.
- DR14 R $SYSRRC.KL = CLIP(SRRC1.K, SRRC2.K, SYSR.K, .5)$
 Note System Reliability Rate of Change (% /year).
- DA56 A $SRRC1.K = (1 - SYSR.K) * TABHL(TSRRC1, SRSL.K / TKPRO.K, 0, 1, .2)$
- DT29 T $TSRRC1 = -.2, -.05, 0, .01, .05, .1$
 Note System Reliability Rate of Change when $SYSR > .5$.
- DA57 A $SRRC2.K = (SYSR.K) * TABHL(TSRRC2, SRSL.K / TKPRO.K, 0, 1, .2)$
- DT30 T $TSRRC2 = -.1, -.01, 0, .03, .1, .2$
 Note System Reliability Rate of Change when $SYSR < .5$.
- DA58 A $DTP.K = TABHL(TDTP, WPNTK.K / (USIAC.K * SWTK.K), 0, 5, 1)$
- DT31 T $TDTP = 15, 10, 8, 7, 6.5, 6.3$

- Note Desired Technology Produced (\$ billion/year).
- DA59 A $SYRSS.K=1-WLSS.K$
 Note System Reliability Spending Share (%) of R&D spending level.
- DA60 A $SRSL.K=SYRSS.K \cdot RDSL.K$
 Note System Reliability Spending Level (\$ billion/year).
- DA61 A $WLSS.K=TABHL(TWLSS,FME.K \cdot WTCE.K,0,100,20)$
- DT32 T $TWLSS=.5,.6,.67,.72,.76,.78$
 Note Weapon Lethality Spending Share (%) of annual R&D
 Note expenditures.
- DA62 A $FME.K=TABHL(TFME,FM.K-DFM.K,-.5,.5,.2)$
- DT33 T $TFME=0,.1,.3,.7,.9,1$
 Note Force Maintainability Effect on lethality spending share.
- DA63 A $WTCE.K=TABHL(TWTCE,WPNTK.K/(USIAC.K \cdot SWTK.K),0,5,1)$
- DT34 T $TWTCE=100,96,90,82,72,60$
 Note Weapon Technology Comparison Effect on system lethality
 Note spending share.
- DA64 A $WLSL.K=WLSS.K \cdot RDSL.K$
 Note System Lethality Spending Level (\$ billion/year).
- DL15 L $INRES.K=INRES.J+(DT \cdot IRRC.JK)$
 N $INRES=9$
 Note Intelligence Resolution (\$ billion).
- DR15 R $IRRC.KL=(ISE \cdot IRSS.K \cdot DSPL.K)-(INRES.K/IDR.K)$
 Note Intelligence Resolution Rate of Change (\$ billion/year).
 C $ISE=.6$
 Note Intelligence Spending Efficiency (%).
- DA65 A $IRSS.K=TABHL(TISS,INRES.K/SINR.K,0,2,.5)$
- DT35 T $TISS=.115,.105,.1,.095,.085$
 Note Intelligence Resolution Spending Share (%) of annual defense
 Note expenditures.
- DA66 A $IDR.K=TABHL(TIDR,INRES.K/SINR.K,0,2,.5)$
- DT36 T $TIDR=2,2.7,3,3.3,4$
 Note Intelligence resolution Depreciation Rate (years).
- DA67 A $USIAC.K=1+USBIAS+(AMP.K \cdot SIN(6.283 \cdot TIME.K/PER))$
 Note US Intelligence Accuracy.
 C $USBIAS=.1$
 Note US intelligence Bias (% overestimation).
- DA68 A $AMP.K=TABHL(TIAC,INRES.K/SINR.K,0,2,.5)$
- DT37 T $TIAC=1.2,.1,.05,.03$
 Note US intelligence accuracy amplifier (dimensionless).
 Note
 Note *** Industry Sector ***
 Note
- IL1 L $ICAP.K=ICAP.J+(DT \cdot ICAPRC.JK)$
 N $ICAP=24$

- Note Industry Capacity (\$ billion annual production capacity).
 IR1 R $ICAPRC.KL = CINV.K + GINV.K - (ICAP.K / CAPDR)$
 Note Industry Capacity Rate of Change (\$ billion/year).
 IA1 A $CINV.K = ICAP.K * TABHL(TCINV.CAPU.K / PRSK.K, 0, 1, .2)$
 IT1 T $TCINV = 0, .02, .03, .035, .038, .04$
 Note Capital Investment (\$ billion annual production capacity).
 IA2 A $GINV.K = WASL.K * GIP.K$
 Note Government Investment (\$ billion annual production capacity).
 IL2 L $GIP.K = GIP.J + (DT * GIPRC.JK)$
 Note Government Investment Percentage (%).
 IR2 R $GIPRC.KL = TAGHL(TGIP, CAPU.K, 0, 1, .2) * GIP.K$
 IT2 T $TGIP = 0, .007, .016, .027, .04, .06$
 Note Government Investment Percentage Rate of Change
 Note (% change/year).
 C $CAPDR = 30$
 Note Capacity Depreciation Rate (years).
 IA3 A $CAPU.K = (FMS.K + (PROR.K * SIP.K * PRCST.K)) / ICAP.K$
 Note Capacity Utilized (%).
 IA4 A $FMS.K = 1$
 Note Foreign Military Sales (\$ billion annual production).
 IA5 A $PRSK. = TABHL(TPRSK, ((UCST.K - PRCST.K) / UCST.K) * CAPU.K, 0, .2, .05)$
 IT3 T $TPRSK = 10, 7, 3, 1, 0$
 Note Industry Perceived Risk (risk index, 0=No risk, 10=high risk).
 IL3 L $ICON.K = ICON.J + (DT * ICONRC.JK)$
 N $ICON = 5$
 Note Industry Concentration (# of competing firms in a single market).
 IR3 R $ICONRC.KL = (TPEC.K + PREC.K + SIPEC.K) * ICON.K$
 Note Industry Concentration Rate of Change (# of firms/year).
 IA6 A $PREC.K = TABLE(TPREC, PRSK.K, 0, 10, 2)$
 IT4 T $TPREC = .05, .02, .007, 0, -.01, -.05$
 Note Perceived Risk Effect on Concentration (% change).
 IA7 A $TPEC.K = TABHL(TTPEC, TKPRO.K / TKAV.K, 0, 1, .2)$
 IT5 T $TTPEC = .02, .005, 0, -.002, -.005, -.02$
 Note Technology Produced Effect on Concentration (% change).
 IA8 A $SIPEC.K = TABHL(TSIP, SIP.K / ICON.K, 0, 4, 1)$
 IT6 T $TSIP = -.3, -.1, -.03, 0, .01$
 Note Systems in Production Effect on Concentration (% change).
 IA9 A $UCST.K = PRCST.K * ICEUC.K$
 Note Smoothed Unit Cost (\$ billion/ unit produced).
 IA10 A $ICEUC.K = TABHL(TICE, ICON.K, 1, 5, 1)$
 IT7 T $TICE = 1.2, 1.15, 1.11, 1.08, 1.07$
 Note Industry Concentration Effect on Unit Cost (dimensionless).
 IL4 L $PRCST.K = PRCST.J + (DT * PCRC.JK)$

N PRCST=.009

Note Production Cost per unit (\$ billion/ unit).

IR4 R $PCRC.KL = (TPEPC.K + PTEPC.K + PREPC.K) * CUEPC.K * PRCST.K$

Note Production Cost Rate of Change (\$ billion/unit/year).

IA11 A $TPEPC.K = TABHL(TTPEPC, TKPRO.K / TKAV.K, 0, 1, .2)$

IT8 T $TTPEPC = -.05, -.02, -.005, 0, .03, .1$

Note Technology Produced Effect on Production Cost

Note (% change/year).

IA12 A $PTEPC.K = TABHL(TPTEPC, PRTK.K, 0, 2, .4)$

IT9 T $TPTEPC = .06, .03, .01, 0, -.01, -.05$

Note Production Technology Effect on Production Cost

Note (% change/year).

IA13 A $PREPC.K = -.1 * (PROR.K - DLINF3(PROR.K, 3)) / PROR.K$

Note Production Rate Change Effect on Production Cost

Note (% change/year).

IA14 A $CUEPC.K = TABHL(TCUEPC, CAPU.K, 0, 1, .2)$

IT10 T $TCUEPC = 3, 1.5, 1.1, 1, .9, 1.1$

Note Capacity Utilization Effect on Production Cost (multiplier).

IL5 L $PRTK.K = PRTK.J + (DT * PTRC.JK)$

N $PRTK = 1.2$

Note Production Technology level (\$ billion).

IR5 R $PTRC.KL = PTS * (CINV.K + GINV.K) - (PRTK.K / PTDR)$

Note Production Technology Rate of Change (\$ billion/ year).

C $PTDR = 10$

Note Production Technology Depletion Rate (years).

C $PTS = .2$

Note Production Technology Share of industry capital investment.

SELECTED BIBLIOGRAPHY

- Allen, R.F. "Shared Monopoly, Oligopoly, and Price-Cost Margins in American Manufacturing." Unpublished manuscript, Air Force Institute of Technology, 1982.
- _____. "Large Firm Efficiency, Concentration, and Profitability in Defense Markets." Proceedings, Federal Acquisition Research Symposium, December 1983.
- Allison, G.T. Essence of Decision. Boston: Little, Brown and Company, 1971.
- Archibald, K., A.J. Harman, M.A. Hesse, J.R. Hiller and G.K. Smith. Factors Affecting the Use of Competition in Weapon System Acquisition (R-2706 -DRE). Santa Monica, CA: Rand Corporation, 1981.
- Associated Press. "Official: Congress' defense-reform plans don't address root of problems." Tallahassee Democrat, 9 April 1986, 6A.
- Augenstein, B. "Military RDT&E: Raison D'Etire and Policy Background." Chap. in Arms, Men, and Military Budgets, ed. W. Schneider and F.P. Hoerber. New York: Crane, Russak & Company, 1976.
- Augustine, N.R. "A Viewpoint of Industry." The Journal of Cost Analysis 2 (Spring 1985): 1-20.
- _____. Augustine's Laws. New York: Viking Penguin Inc, 1986.
- Axelrod, R. Structure of Decision. Princeton, NJ: Princeton University Press, 1976.
- Bain, J.S. Industrial Organization. New York: Wiley, 1959.
- Baldwin, W.L. The Structure of the Defense Market, 1955-1964. Durham, NC: Duke University Press, 1967.
- Banks, J. and J.S. Carson. Discrete-Event System Simulation. Englewood Cliffs, NJ: Prentice-Hall, 1984.

- Barker, R.W. and K.C. Konwin. "Department of Defense Capital Investment Incentive Policy: A System Dynamics Model and Analysis." Master's Thesis, Air Force Institute of Technology, 1982.
- Baseman, L.T. "Cost Growth in the Acquisition of Weapon Systems: Experience, Causes, Understanding of and Positive Responses Thereto." The Journal of Cost Analysis Vol.1 No.1 (Spring 1984): 101-114.
- Beatty, J. "In Harm's Way." The Atlantic Monthly, May 1987, 37-53.
- Beer, S. Decision and Control. New York: John Wiley & Sons, 1967.
- Bell, J.A. and J.F. Bell. "System Dynamics and Scientific Method." Chap. in Elements of the System Dynamics Method, ed. J. Randers, Cambridge, MA: The MIT Press, 1980.
- Bell, J.A. and P.M. Senge. "Methods for Enhancing Refutability in Systems Dynamics Modeling." In A.A. Legasto, J.W. Forrester and J.J. Lyneis, eds., System Dynamics. Amsterdam: North-Holland Publishing Company, 1980.
- Beltramo, M.N. Dual Production Sources in the Procurement of Weapon Systems: A Policy Analysis (P-6911-RGI). Santa Monica, CA: Rand Corporation, 1983.
- Berry, F.C. "Fallacies and Facts About Aerospace." Air Force Magazine, February 1988, 68-74.
- Bickner, R.E. The Changing Relationship Between the Air Force and the Aerospace Industry (RM-4101-PR). Santa Monica, CA: Rand Corporation, 1964.
- Bobrow, D.B., ed. Weapons System Decisions. New York: F.A. Praeger, 1969.
- Borklund, C.W. The Department of Defense. New York: Praeger, 1968.
- Breary, J.L. "An Analysis of the Impact of Multi-Year Procurement on Weapon System Acquisition." Master's Thesis, Air Force Institute of Technology, 1981.
- Breckner, N.V. "Government Efficiency and the Military 'Buyer-Seller' Device." Journal of Political Economy 5 (October 1960): 454-475.

- Brooks, L.F. "The Problem of Quality and Quantity." In J.F. Reichart and S.R. Sturm, eds., American Defense Policy, 5th edition. Baltimore, MD: The Johns Hopkins University Press, 1983.
- Brown, G.F. and L. Korb. "The Economic and Political Constraints on Force Planning." In J.F. Reichart and S.R. Sturm, eds., American Defense Policy, 5th edition. Baltimore, MD: The Johns Hopkins University Press, 1983.
- Canan, J.W. "The Profitability of Defense." Air Force Magazine, November 1985, 62-67.
- _____. "Acid Test for Aeronautical Technology." Air Force Magazine, January 1986, 38-45.
- _____. "Producibility." Air Force Magazine, October 1986, 72-82 .
- Carlucci, F.C., Deputy Secretary of Defense. Memorandum on Improving the Acquisition Process. Washington, D.C.: GPO, 1981.
- Carrington, T. "Officials Dispute Pentagon Study of Defense Profits." Wall Street Journal, 11 September 1985, 26.
- Chace, J. "Ike Was Right." The Atlantic Monthly, August 1987, 39-41.
- Charles, R.H. "Better Competition Means Cheaper Arms." Wall Street Journal, 4 September 1987, 14.
- Choucri, N. and R.C. North. Nations in Conflict: National Growth and Internal Violence. San Francisco: W.H. Freeman and Co., 1975.
- Churchman, C.W. The Systems Approach. New York: Delacorte Press, 1968.
- Clark, R. "Defense Spending Can Decline." Los Angeles Times, 28 October 1985.
- Clark, T.D. "A Management Systems Analysis of the Arms Transfer Process." Decision Sciences 17 (Fall 1986): 517-557.
- _____. "Decision Support System Design and Evolution: A Structured Dynamic Theory." Center for Information Systems Research working paper (87-1-3), Florida State University, 1987.

Clark, T.D., E.L. Whittenberg and A.H. Woodruff, "A Policy Analysis of Defense Weapons Acquisition." Policy Studies Journal 14 (September 1985): 21-45.

Collins, J. American and Soviet Military Trends. Washington, D.C.: The Center for Strategic and International Studies, 1978.

_____. U.S. - Soviet Military Balance 1980-1985. Washington, D.C.: Pergamon-Brassey, 1985.

Comptroller General of the United States. Defense Industry Profit Study (GAO Report No. B-159896). Washington, D.C.: GPO, 1971.

Comptroller of the Air Force. United States Air Force Summary. Washington, D.C.: Headquarters United States Air Force, 1986.

Correll, J.T. "The Little Big Deal." Air Force Magazine, December 1984, 4.

_____. "The Pros and Cons of Competition." Air Force Magazine, February 1986, 54-55.

_____. "The Risks of Austerity." Air Force Magazine, February 1988, 4.

_____. "The Five Year Drought." Air Force Magazine, February 1988, 16-20.

Coulam, R. Illusions of Choice. Princeton, NJ: Princeton University Press, 1977.

Coyle, R.G., Management System Dynamics. New York: Wiley, 1977.

Davis, J.A. The Logic of Causal Order. Quantitative Applications in the Social Sciences Series. Hollywood, CA: Sage Publications, 1985.

Defense Science Board. Report of the Acquisition Cycle Task Forces: 1977 Summer Study. Washington, D.C.: Office of the Under Secretary of Defense for Research and Engineering, 1978.

_____. Report on Defense Semiconductor Dependency. Washington, D.C.: Office of the Under Secretary of Defense for Acquisition, 1987.

Department of Defense. Defense Financial and Investment Review. Final Report. Washington, D.C.: GPO, 1986.

- Dews, E., G.K. Smith, A. Barbour, E. Harris, and M. Hesse. Acquisition Policy Effectiveness: Department of Defense Experience in the 1970s (R-2516-DRE). Santa Monica, CA: Rand Corporation, 1979.
- Dews, E. and J. Birkler. Reform in Defense Acquisition Policies: A Different View (P-6927). Santa Monica, CA: Rand Corporation, 1983.
- Dyer, G. War. New York: Crown Publishers, 1985.
- Enthoven, A.C. and K.W. Smith. How Much is Enough. New York: Harper and Row, 1971.
- Fallows, J.M. National Defense. New York: Random House, 1981.
- _____. "The Spend-up." The Atlantic Monthly, July 1986, 27-31.
- Fitzgerald, A.E. The High Priests of Waste. New York: W.W. Norton and Co., 1972.
- Foelber, R.E., A Defense Budget Primer, Congressional Research Service, Report No. 85-85F, 1985.
- Forrester, J.W. Industrial Dynamics. Cambridge, MA: MIT Press, 1961.
- _____. Principles of Systems. Cambridge MA: MIT Press, 1966.
- Forrester, J.W. and P.M. Senge. "Building Confidence in System Dynamics Models." In A.A. Legasto, J.W. Forrester and J.J. Lyneis, eds., System Dynamics. Amsterdam: North-Holland Publishing Company, 1980.
- Fox, J.R. Arming America. Cambridge, MA: Harvard University Press, 1974.
- Gansler, J.S. The Defense Industry. Cambridge, MA: The MIT Press, 1980.
- _____. "We Can Afford Security." Foreign Policy, 51 (Summer 1983): 64-83.
- _____. "What Ails the Acquisition Process?" Air Force Magazine, July 1985, 94-101.
- _____. "Defense program instability: causes, costs, and cures." Defense Management Journal (Second Quarter 1986): 3-11.

_____. "The Issues That Must Be Addressed." Government Executive (February 1987): 18-20.

_____. "Strengthening the Defense Industrial Base," Testimony before the Senate subcommittee on defense industry and technology, Senate Armed Services Committee 16 March, 1987.

Gansler, J.S. and Louis Kratz. "Effective Competition During Weapon System Acquisition." Contract Management (March 1986): 16-17.

Gapinski, J.H. Macroeconomic Theory: Statics, Dynamics, and Policy. New York: McGraw-Hill, 1982.

Gilleece, M.A. "DOD Acquisition Management." The Journal of Cost Analysis 2 (Spring 1985): 21-30.

Goldwater, B. "Overdose of Oversight and Lawless Legislating." Armed Forces Journal International, February 1987.

Goodell, F.S. "More Sorties - Less Support." Air Force Magazine, October 1987, 56-68.

Greenberg, E. Government-Owned Plant Equipment Furnished to Contractors: An Analysis of Policy and Practice (RM-6024-1-PR). Santa Monica, CA: Rand Corporation, 1969.

Greenberger, M., M.A. Crenson and B.L. Crissey. Models in the Policy Process. New York: Russell Sage Foundation, 1976.

Greer, W.R. and S.S. Liao. "Contractor Hungriness and the Relative Profitability of DOD Business." Master's Thesis, Naval Postgraduate School, 1983.

Haass, R. "The Role of the Congress in American Security Policy". In J.F. Reichart and S.R. Sturm, eds., American Defense Policy, 5th edition. Baltimore, MD: The Johns Hopkins University Press, 1983.

Hall, R.I. "A System Pathology of an Organization: The Rise and Fall of the Old Saturday Evening Post." Administrative Science Quarterly (March 1976): 185-211.

_____. "The Natural Logic of Management Policy Making: Its Implications for the Survival of an Organization." Proceedings of the 1983 International Systems Dynamics Conference 2 (July 1983): 533-556.

Hall, R.I. and W.B. Menzies. "A Corporate System Model of a Sports Club Using Simulation as an Aid to Policy Making in a Crises." Management Science 29 (January 1983): 52-64.

Halloran, R. To Arm a Nation. New York: MacMillan, 1986.

Harman, H., A.J. Alexander, M.R. Davis, and A.D. Lee. Technological Innovation by Firms: Enhancement of Product Quality (R-2237-NSF). Santa Monica, CA: Rand Corporation, 1977.

Harris, B. "Quantitative Models of Urban Development: Their Role in Metropolitan Decision Making," in H. S. Perloff and L. Wingo (eds.), Issues in Urban Economics. Baltimore: The Johns Hopkins University Press, 1968.

Hart, G. and W.S. Lind. America Can Win. Bethesda, MD: Adler and Adler, 1986.

Hodge, F.P. and W.J. Vogt. Improving Intergovernmental Mobilization: Development and Demonstration of the TASCMAIN and TASCFORM-MOBE Models (TR-5165-1). Arlington, VA: The Analytical Sciences Corporation, 1985.

Kahn, A.E. "The Relevance of Industrial Organization," in J.V. Craven (ed.), Industrial Organization, Anti-trust, and Public Policy. Boston: Kluwer-Nijoff, 1983.

Kaffenberger, S.A. and D.P. Martin. "A Dynamic Policy Model of the Defense System Acquisition Process." Master's Thesis, Air Force Institute of Technology, 1979.

Katzenbach, E.L. "Tradition and Technological Change." In J.F. Reichart and S.R. Sturm, eds., American Defense Policy, 5th edition. Baltimore, MD: The Johns Hopkins University Press, 1983.

Kennedy, P. "What Gorbachev Is Up Against." Atlantic Monthly, June 1987, 29-43.

_____. "The (Relative) Decline of America." Atlantic Monthly, August 1987, 29-38.

Kerlinger, F.N. Foundations of Behavioral Research (2nd ed.). New York: Holt, Rhinehart and Winston, 1973.

Kirkpatrick, D.L.I. and P.G. Pugh. "Towards the Starship Enterprise - Are the Current Trends in Defence Unit Costs Inexorable?" The Journal of Cost Analysis 2 (Spring 1985): 59-80.

Knight, R. "Fresh wine in old battlers." U.S. News and World Report, 15 February 1988, 53-55.

Koch, N.C. "USA/USSR: Assymetries in Objectives and in Capabilities." Security Commitments and Capabilities, ed. U. Ra'anam and R.L. Pfaltzgraff, pp-pp. Hamden, CN.: Archon Books, 1985.

Korb, L.J. The Fall and Rise of the Pentagon. Westport, CN.: Greenwood Press, 1979.

Kotz, N. Wild Blue Yonder: Money, Politics and the B-1 Bomber. New York: Pantheon, 1988.

Large, J., K. Hoffmayer and F. Kontrovich. Production Rate and Production Cost (R-1609-PAE). Santa Monica, CA: Rand Corporation, 1974.

Lee, A.D. A Strategy to Improve the Early Production Phase in Air Force Acquisition Programs (P-6941). Santa Monica, CA: Rand Corporation, 1983.

Lee, W.T. "Soviet Defense Expenditures." In W. Schneider and F.P. Hoerber (eds.), Arms, Men, and Military Budgets. New York: Crane, Russak & Company, 1976.

_____. The Estimation of Soviet Defense Expenditures 1955-1975. New York: Praeger 1977.

Legasto, A.A., J.W. Forrester and J.M. Lyneis, ed. System Dynamics. New York: North-Holland, 1980.

Lewin, A.Y. Decision Process Models of Contractor Behavior: The Development of Effective Contract Incentives. Air Force Business Research Management Center, 1981.

Los Angeles Times. "Reagan to appoint overseer for Pentagon purchases." Tallahassee Democrat, 3 April 1986, 3A.

Luttwak, E.N. "Perceptions of Military Force and U.S. Defense Policy," Strategy and Politics. New Brunswick: Transaction Books, 1980.

_____. The Pentagon and the Art of War. New York: Simon and Schuster, 1984.

MAC Group. The Impact on Defense Industrial Capability of Changes in Procurement and Tax Policy 1984-1987. MAC Group, Washington D.C., February 1988.

Marsh, R.T. "Packard's Partial Fix." Air Force Magazine, May 1986, 198-201.

_____. "Oversight is Overdone." Air Force Magazine, October 1986, 63-65.

McKie, J.W. Concentration in Military Procurement Markets: A Classification and Analysis of Contract Data (RM-6307-PR). Santa Monica, CA: Rand Corporation, 1970.

Meadows, D.L., D.H. Meadows, J. Randers, and W.W. Behrens III. The Limits to Growth. New York: Universe Books, 1972.

Melloan, G. "Even Generals Get the Arms-Procurement Blues." The Wall Street Journal, 23 June 1987, 31.

Moore, M. "The Billion-Dollar Bomber Without a Brain." The Washington Post National Weekly Edition, 24 August 1987, 31.

_____. "Any Shopper Could Have Told the Pentagon." The Washington Post National Weekly Edition, 28 December 1987, 32.

_____. "The MX Missile Mess." The Washington Post National Weekly Edition, 17 January 1988, 9-10.

Morocco, J., "Trumps in Danger." Air Force Magazine, February 1987, 70-73.

Nicholson, W. Microeconomic Theory. Hinsdale: The Dryden Press, 1978.

Office of the Assistant Secretary of Defense. Profit '76 Summary Report. Washington, D.C.: GPO, December 1976.

Olvey, L.D., J.R. Golden and R.C. Kelly. The Economics of National Security. Wayne, IN: Avery Publishing Group, 1984.

Owen, D. The Politics of Defense. New York: Taplinger Publishing Co., 1972.

- Peck, M.J. and F.M. Scherer. The Weapons Acquisition Process: An Economic Analysis. Cambridge, MA: Harvard University Press, 1962.
- Perry, R. Reforms in System Acquisition (P-5482). Santa Monica, CA: Rand Corporation, 1975.
- _____. The Interaction of Technology and Doctrine in the USAF (P-6281). Santa Monica, CA: Rand Corporation, 1979.
- Perry, R., G.K. Smith, A.J. Harman, and S. Henrichsen. System Acquisition Strategies (R-733-PR/ARPA). Santa Monica, CA: Rand Corporation, 1971.
- Peterson, P.G. "The Morning After." The Atlantic Monthly, October 1987, 43-69.
- President's Blue Ribbon Defense Panel. Report to the President and the Secretary of Defense on the Department of Defense. Washington, D.C.: GPO, 1970.
- President's Blue Ribbon Commission of Defense Management. A Quest for Excellence: Final Report to the President. Washington, D.C.: GPO, 1986.
- President's Private Sector Survey on Cost Control. Final Report on the Department of Defense. Washington, D.C.: GPO, 1983.
- Randers, J., ed. Elements of the System Dynamics Method. Cambridge, MA: MIT Press, 1980.
- _____. "Guidelines for Model Conceptualization." In Elements of the System Dynamics Method. Cambridge, MA: MIT Press, 1980.
- Rasor, D. The Pentagon Underground. New York: Times Books, 1985.
- Reich, R.B. "The Rise of Techno-Nationalism." The Atlantic Monthly, May 1987, 63-69.
- Reichart, J.F. and S.R. Sturm, eds. American Defense Policy, 5th edition. Baltimore, MD: The Johns Hopkins University Press, 1983.
- Rich, M.D. Competition in the Acquisition of Major Weapon Systems: Legislative Perspectives (R-2058-PR). Santa Monica, CA: Rand Corporation, 1976.

- Rich, M.D., E. Dews and C. Batten. Improving the Military Acquisition Process: Lessons from Rand Research (R-3373-AF/RC). Santa Monica, CA: Rand Corporation, 1986.
- Richardson, G.P. and A.L. Pugh III. Introduction to System Dynamics Modeling with Dynamo. Cambridge, MA: MIT Press, 1981.
- Roberts, E.B., ed. Managerial Applications of System Dynamics. Cambridge, MA: MIT Press, 1978.
- Russett, B. The Prisoners of Insecurity. San Francisco: W.H. Freeman and Co., 1983.
- Samuelson, P.A. Economics, 11th ed. New York: McGraw-Hill, 1980.
- Sapp, R.S. The Procurement Process and Program Cost Outcomes: A Systems Approach. PhD Thesis, Purdue University, 1971.
- Shapiro, R.J. "A frightening new numbers game." U.S. News and World Report, 28 September 1987, 8 and 13.
- Scherer, F.M. The Weapons Acquisition Process: Economic Incentives. Cambridge, MA: Harvard University Press, 1964.
- _____. "The Aerospace Industry," The Structure of American Industry. Adams, ed., MacMillan, New York, 1970.
- Schneyer, F.A. "A checkered past at General Dynamics." Tallahassee Democrat, 11 October 1987, 1E.
- Schoderbek, C.G., P.P. Schoderbek, and A.G. Kefalas. Management Systems: Conceptual Considerations, 3rd edition. Dallas, TX: BPI, Inc., 1984.
- Scott, W.F. "Moscow's Military-Industrial Complex." Air Force Magazine, March 1987, 47-51.
- Shannon, R.E. Systems Simulation: The Art and Science. Englewood Cliffs, NJ: Prentice-Hall, 1975.
- Shepherd, W.G. The Economics of Industrial Organization. Englewood Cliffs, NJ: Prentice-Hall, 1979.
- Simon, J. Basic Research Methods in Social Science. New York: Random House, 1969.

- Smith, G.K., A.A. Barbour, T.L. McNaugher, M.D. Rich, and W.L. Stanley. The Use of Prototypes in Weapon System Development (R-2345-AF). Santa Monica, CA: Rand Corporation, 1981.
- Smith, G.K. and E. Friedmann. An Analysis of Weapon System Acquisition Intervals. Past and Present (R-2605-DRE/AF). Santa Monica, CA: Rand Corporation, 1980.
- Smith, J. and M. Moore. "Pentagon's Purchasing Chief to Quit." The Washington Post, 14 September 1987, A1 and A16.
- Stanley, W.L. and M.D. Miller. Measuring Technological Change in Jet Fighter Aircraft (R-2249-AF). Santa Monica, CA: Rand Corporation, 1979.
- Steinbruner, J.D. The Cybernetic Theory of Decision. Princeton, NJ: Princeton University Press, 1974.
- Stekler, H.D. The Structure and Performance of the Aerospace Industry. Los Angeles: University of California Press, 1965.
- Stenberg, I. "Modeling Procedure for Public Policy." Chap. in Elements of the System Dynamics Method, ed. J. Randers, Cambridge, MA: The MIT Press, 1980.
- Stockman, D.A. The Triumph of Politics. New York: Harper & Row, 1986.
- Stubbing, R.A. The Defense Game. New York: Harper & Row, 1986.
- Sweeney, P.J. "A Systems Dynamics Model of the Acquisition Process." Master's Thesis, Air Force Institute of Technology, 1981.
- Thompson, M. "Support for weapon sinks as costs rise." Tallahassee Democrat, 10 January, 1988, 1A and 6A.
- _____. "Budget cutbacks shortchange defense research." Tallahassee Democrat, 3 April, 1988, 1A and 2A.
- Trice, R.H. "The Policymaking Process: Actors and Their Impact." In J.F. Reichart and S.R. Sturm, eds., American Defense Policy, 5th edition. Baltimore, MD: The Johns Hopkins University Press, 1983.
- Ulsamer, E. "The Packard Report." Air Force Magazine, April 1986, 21-22.

United States Air Force Systems Command. Payoff 80 Executive Report.
Washington, D.C.: GPO, October 1980.

Weida, W.J. and F.L. Gertcher. The Political Economy of National Defense.
Boulder, CO: Westview Press, 1987.

White, E. "Despite Big Risks, Defense Industry Attracts Suitors." The Wall Street Journal, 17 November 1987, 6.

_____. "Defense Industry Slims Down to Survive." The Wall Street Journal, 30 September 1987, 6.

Wilson, G.C. "The Pentagon Is Reducing Manpower to Save Machines." The Washington Post Weekly Edition, 15 February 1988, 35.