

AD-A197 403



DTIC FILE COPY

BUILDING FOR ENERGY CONSERVATION

BY

ROBERT E. MERTON

A REPORT PRESENTED TO THE GRADUATE COMMITTEE
OF THE DEPARTMENT OF CIVIL ENGINEERING IN
PARTIAL FULFILLMENT OF THE REQUIREMENTS
FOR THE DEGREE OF MASTER OF ENGINEERING

UNIVERSITY OF FLORIDA

SUMMER 1968

DTIC
ELECTE
S & D
AUG 18 1968
E

This document has been approved
for public release and sale in
distribution is unlimited.

88 8 16 011

BUILDING FOR ENERGY CONSERVATION

BY

ROBERT E. MERTON

Spec 85-9 222

A REPORT PRESENTED TO THE GRADUATE COMMITTEE
OF THE DEPARTMENT OF CIVIL ENGINEERING IN
PARTIAL FULFILLMENT OF THE REQUIREMENTS
FOR THE DEGREE OF MASTER OF ENGINEERING



UNIVERSITY OF FLORIDA

SUMMER 1988

Accession For	
NTIS GRA&I	<input checked="" type="checkbox"/>
DTIC TAB	<input type="checkbox"/>
Unannounced	<input type="checkbox"/>
Justification	<i>form 50 per</i>
By	
Distribution/	
Availability Codes	
Dist	Avail and/or Special
<i>A-1</i>	

This document has been approved
for public release and sale in
distribution is unlimited.

TABLE OF CONTENTS

	PAGE
PREFACE	P-1
LISTS OF TABLES	i
LISTS OF FIGURES	ii
INTRODUCTION	I-1
CHAPTER ONE - WHY CONSERVE ENERGY?	1-1
CHAPTER TWO - ENERGY USAGE IN BUILDINGS	2-1
CHAPTER THREE - ENERGY LOSSES IN BUILDINGS	3-1
CHAPTER FOUR - CLIMATIC EFFECTS AND CONSIDERATIONS	4-1
CHAPTER FIVE - IMPROVING THE EFFICIENCY OF BUILDINGS	5-1
CHAPTER SIX - ALTERNATE SOURCES	6-1
CONCLUSION	C-1
REFERENCES	R-1
BIBLIOGRAPHY	B-1

PREFACE

Man's ability to convert energy from one form to another has allowed for tremendous technological advances, the domination of the environment, as well as the proliferation of the species. The extended use and misuse of these same processes may also provide the means for the eventual demise of the human race.

According to present theories even the universe contains a limited amount of energy. A sphere constructed around any portion of the universe would be found to contain a specific amount of available energy, not necessarily all in the same form. It would also be found that that same sphere would be capable of receiving and discharging energy at specific rates.

The earth may be considered to be such a sphere. It contains a specific amount of energy, and it absorbs and dissipates energy at specific rates. As a result these rates determine the amount of heat that may be inserted into the atmosphere before the climate is seriously affected.

Not too long ago the general population considered the earth's energy reserves to be essentially inexhaustible. However, during the early 1970's an oil embargo brought attention to the fact that the earlier assumption was not valid. Some projections indicated that

the supplies would be exhausted by the turn of the century, while others projected an energy supply available for several hundred years. Either way, the projections agreed that the earth's supplies were indeed limited.

Rarely will one process affect only itself. In addition to the problem of depleting the energy reserves of the earth there were several side effects to be considered. The first was the environmental pollution generated by the conversion of fossil fuels to energy in the forms of gasses and particulates. The second is the waste heat generated in the various conversion processes. The third area of consideration is the disposal of the spent fuels, especially those generated by nuclear reactors. The fourth is the political consideration as more and more of the earth's peoples attempt to raise their standard of living.

The ability to convert energy has placed the human race on the threshold of being able to leave this planet, hopefully, to continue to advance and make peaceful use of other portions of the universe. If, however, the energy supplies are exhausted, or required just to maintain a standard of living before this occurs, it will not be possible to take advantage of the tremendous potential available.

To expect a massive reduction in energy usage is impractical, and conservation in one sector alone will not completely eliminate the energy shortage. However, it will contribute to the extension of the length of time the usable energy reserve will be available. In addition, conservation and more efficient use of the available resources will result in moving the theoretical 'heat rejection' limit further into the future. Because the percentage of energy used in buildings is quite high, up to twenty five percent of the national total, it becomes necessary to examine ways to reduce that use and make better use of the available energy sources.

Owners, designers, and occupants of buildings must be conscious of the need to utilize energy efficiently. Owners need to become more familiar with the overall life cycle cost associated with a building. As the cost of energy escalates this area will become increasingly important in the life cycle cost evaluation. Owners frequently underestimate the costs associated with energy and therefore fail to include energy saving options in building plans. A considerable amount of energy may be saved by training the occupants of a structure how to conserve energy, and this process is in progress. The occupants, however, are only a portion of the solution.

It is possible to construct buildings that are much more energy efficient than those constructed in the recent past. There is a significant amount of information in this area and the technology is changing rapidly. It is necessary for designers to become aware of this information and remain current as the changes occur. Designers should then incorporate this information into building plans.

This report is not intended to provide a detailed look at the many theories and available options, since entire books have been written on subjects that are here allotted but several paragraphs. It is the intention of this report to briefly examine this subject area in order to promote an interest in this subject. It is hoped that once such an interest is developed, the reader will pursue these areas and develop an in-depth knowledge.

LIST OF TABLES

	PAGE
CHAPTER ONE	
1-1 ENERGY EQUIVALENTS OF VARIOUS MATERIALS	1-7
1-2 CONVENTIONAL FUEL RESERVES	1-8
1-3 ESTIMATED LIVES OF ENERGY RESOURCES	1-8
1-4 WORLD RECOVERABLE ENERGY RESERVES (1974)	1-9
1-5 WORLD ENERGY USAGE PER CAPITA	1-10
CHAPTER TWO	
2-1 METABOLIC RATES FOR DIFFERENT ACTIVITY LEVELS	2-7
2-2 SAMPLE RESISTANCES OF CLOTHING	2-8
2-3 SENSIBLE AND LATENT HEAT GENERATED	2-10
2-4 RECOMMENDED LIGHTING LEVELS	2-11
CHAPTER THREE	
3-1 CONDUCTANCE VALUES FOR WINDOWS	3-6
CHAPTER FIVE	
5-1 R-VALUES OF TYPICAL CONSTRUCTION MATERIAL	5-8
5-2 EFFECT OF ADDING INSULATION TO A WALL	5-9
5-3 ENERGY USE OF BUILDINGS BY TYPE COMMERCIAL	5-12
5-4 ENERGY USE OF BUILDINGS BY TYPE RESIDENTIAL	5-13

LIST OF FIGURES

	PAGE
INTRODUCTION	
I-1 ENERGY USAGE BY SOURCE IN THE U.S.	I-6
CHAPTER ONE	
1-1 RENEWABLE AND NONRENEWABLE ENERGY SOURCES	1-11
1-2 ENERGY FLOW FOR THE EARTH	1-12
1-3 PROJECTED ENERGY USE PER CAPITA	1-13
CHAPTER TWO	
2-1 COMFORT ZONE	2-6
2-2 COOLING CAPACITY VS ACTIVITY LEVEL	2-9
CHAPTER THREE	
3-1 ENERGY LOSSES FROM A BUILDING	3-4
3-2 HEAT TRANSFER THROUGH A WALL	3-5
3-3 HEAT GAINS TO A BUILDING	3-7
CHAPTER FOUR	
4-1 HEATING AND COOLING ZONES FOR THE U.S.	4-5
4-2 SAMPLE PRELIMINARY DESIGN PREPARATIONS	4-6
4-3 SAMPLE PRELIMINARY DESIGN PREPARATIONS	4-7
4-4 SAMPLE PRELIMINARY DESIGN PREPARATIONS	4-8
4-5 SAMPLE PRELIMINARY DESIGN PREPARATIONS	4-9
4-6 SAMPLE PRELIMINARY DESIGN PREPARATIONS SUMMARY	4-10
CHAPTER FIVE	
5-1 INSULATION COSTS VS THICKNESS	5-10
5-2 THERMAL CONDUCTANCE OF VARIOUS WINDOW TYPES	5-11

LIST OF FIGURES(CONT)

CHAPTER SIX

6-1	ENERGY SOURCE FOR THE EARTH	6-8
6-2	SOLAR ENERGY AVAILABLE IN THE U.S.	6-9
6-3	PASSIVE SOLAR DESIGN	6-10
6-4	ACTIVE SOLAR SYSTEM	6-11
6-5	FLAT PLATE SOLAR COLLECTORS	6-12
6-6	CONCENTRATING SOLAR COLLECTORS	6-13
6-7	EARTH/WATER HEATING AND COOLING SYSTEM	6-14
6-8	HORIZONTAL EARTH COIL	6-15
6-9	VERTICAL EARTH COIL	6-16
6-10	COOL TUBE	6-17
6-11	WATER SYSTEMS	6-18

INTRODUCTION

Man has been utilizing energy in various forms since the prehistoric era. Controlling fire was probably the earliest use of energy. The control of fire is considered by some to be the single most important step in the proliferation of the species. Controlling fire allowed early peoples to preserve food, scare off predators, stay warm, and in the evening gather around for various social events. Used in comparatively limited quantities, as was the case in most early civilizations, the fuel for fires was abundant, and most important, renewable.

As time passed, animals, wind, water, and coal to subsidize wood, were harnessed to provide energy sources for the various requirements of the human race. These sources of energy, with the exception of coal, were generally renewable.

A major change took place in the seventeenth and eighteenth centuries in the western world, the industrial revolution. With the advent of the industrial machines of the era, and especially after the invention of the steam engine, human use of energy assumed an entirely different form. It became possible to concentrate tremendous amounts of energy in one area and produce enormous amounts of work. The standard of living rose over time and as demand increased, so did the consumption of energy.

In the United States wood, wind, and water served as the energy mainstay until shortly after the Civil War. Soon after, coal became the prime source of energy and remained as such until after WW II, when it was replaced by gas and oil (Figure I-1). The change in America's primary source of energy was not the result of shortages or perceived shortages, but due to technological advances.

It has only been in the last fifteen years that the general population has become aware that the fossil and other non-renewable energy reserves of the earth are not infinite. The realization that the energy reserves had finite limits came about as the result of an economic embargo and the efforts of various environmentalist groups. The result was an intense interest in energy conservation and the investigation of alternate sources. Some of the interest has waned as the economy has absorbed the impact of the embargo, however, with the projections that have been made people must be aware of the limitations in the energy resources of the earth.

Unfortunately, nuclear power had failed to be the cheap abundant energy source as was originally envisioned by the early researchers in the field. As a result it has become apparent that energy will be provided in the future by a number of sources, depending upon the

availability and economics of the particular need. It will be necessary for these various alternative energy sources to be assimilated into society at costs which may at times be above the level expected by the general population. As these costs escalate and the supplies of oil and gas diminish, conservation of energy will become increasingly more important.

America's energy consumption may be divided into four main areas; electricity generation, transportation, industrial production, and energy consumed in buildings. Each of these areas have potential for conservation programs. This paper will examine the fourth area, the energy consumed by buildings.

Energy conservation is not consistently defined. To some people it means a reduction in the use of fossil fuel energy, to others it means a reduction in all forms of energy usage and requires a change of life style. To still others, it means a reduction in energy usage without a major change in life style. The definition that is accepted most widely implies the judicious use of the energy reserves with increased reliance on renewable sources, with a minimal impact upon social and economic life styles. To measure energy conservation, some form of standard must be utilized as a measurement against which comparisons are based. In the case of an

existing building it is common to use past energy consumption as a basis for future goals. In new buildings it may be necessary to utilize consumption per square foot, as compared to other similar buildings, consumption per capita based upon occupancy and an established standard, or some other measurable standard for comparison.

America enjoys a standard of living far above the majority of the rest of the world and as will be shown consumes a disproportionate amount of energy. It is therefore imperative that energy conservation measures be implemented in the U.S.

The effort to conserve energy in buildings begins with the owner. Without the owner's involvement, energy conservation efforts will be fruitless. When there is a direct economic return over a given period of time, or a cost avoidance may be shown, owners will generally support energy conservation programs and energy efficient construction. In the case of new buildings, or those under design for a retro fit, the designer is the next important person in constructing an energy efficient building. Often times a building is designed to produce a desired effect, or utilize certain materials at the expense of being energy efficient. A designer's knowledge and use of energy efficient materials and systems is

paramount in design recommendations to the owner. The contractor should also be aware of energy conserving materials and equipment and make recommendations to the designer and/or owner as the case may be. Finally the occupants of the structure must operate in such a manner as to minimize energy waste.

Energy Usage By Source In The U.S.

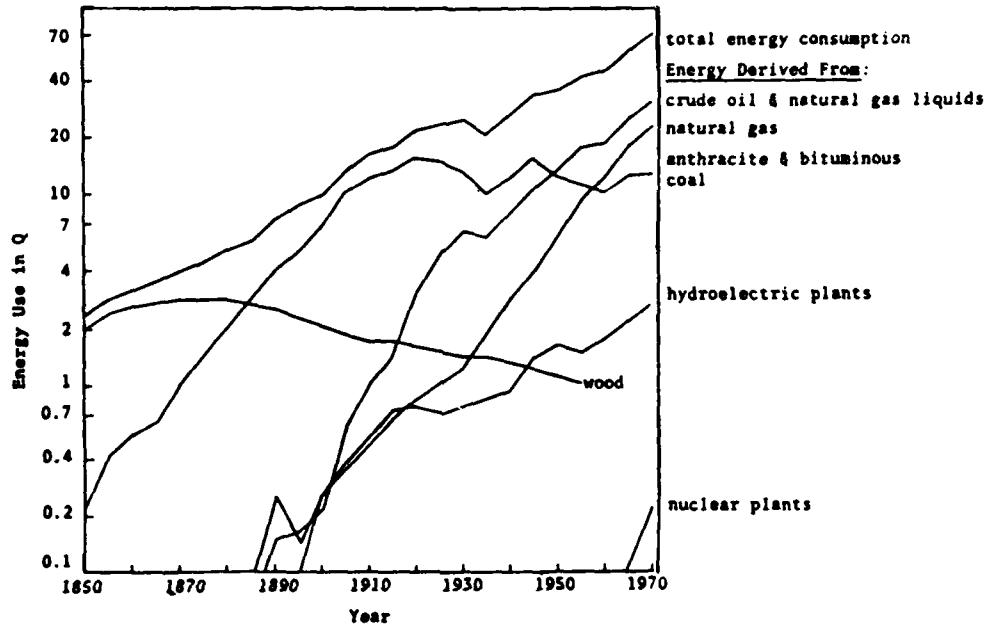

Annual energy consumption by source in the United States for the period 1850 to 1970; based on data of the United States Department of Commerce. Hydroelectric and nuclear energy are converted to thermal energy at the average efficiency of fossil-fuel plants operating during the specified year. The data are plotted for five-year intervals.

Q = QUADRILLION BTU'S

FIGURE I-1

(1)

Chapter One

Why Conserve Energy?

One definition of energy is the ability to do work, and that ability may be available as either potential or kinetic energy. Since energy may produce work, some form of measurement of this ability may be developed and used. From these measurements it is then possible to determine the amount of work that may be performed, and also how long that work may be performed.

The United States uses the British Thermal Unit (BTU) in energy computations. One BTU is equal to 252 calories. One calorie is the amount of energy to raise the temperature of one gram of water, one degree celsius, starting at a standard temperature and pressure. For comparison one gallon of gasoline (unleaded) contains about 115,000 BTU's and one kilowatt hour of electricity contains about 3,413 BTU's. There are about 12,000 BTU's in one pound of bituminous coal, while one gram of uranium 235 (fissionable) contains 74,000,000 BTU's. Table 1-1 lists several other energy equivalents of materials.

There are varying estimates as to the amounts of extractable energy reserves that remain in the earth. The uncertainty associated with these estimates is the result of geological, geographical, political, and technological

factors. In any case, as shown by Tables 1-2, 1-3, and 1-4, the reserves are not infinite, as was perceived only a short time in the past.

As a general rule the consumption of energy per capita may be related to the Gross National Product (GNP), however, in recent years the U.S. per capita use has exceeded the estimates provided by those computations. It has been calculated that a person requires .15KW in the form of food to survive. The U.S. per capita use is forty-eight times that minimum. An examination of Table 1-5 will also show that the United States consumes almost 1.5 times the energy average per capita of industrialized nations and 21.82 times the world average.

Energy is available in many forms; mechanical, chemical, electrical, nuclear, and heat. It may be converted from one form to another, assuming the technology is available. From a global viewpoint, several sources are renewable, such as wind, waves, solar, and within limits, wood. Other sources of energy are consumable and will eventually be depleted. These are the fossil fuels, such as oil, gas, and coal. Nuclear fuels derived from radioactive materials are generally considered to be consumable. However, there is some research being done utilizing 'breeder reactors' to produce more nuclear fuel. In addition, nuclear fusion

is being developed towards providing a significant amount of power. There are several sources which may be placed in either category depending upon the classification process. Figure 1-1 shows these classifications.

The process of converting energy from fuel into a form our technology can utilize involves significant losses. This conforms with the second law of thermodynamics which states: that in any energy transaction, there is a decrease in the amount of useful energy available for future transactions. However, it is possible to minimize those losses as much as technology will permit. A measure of the success of an energy transaction may be expressed as efficiency. Efficiency expressed as a percentage is the energy output divided by the energy input, times 100. For example an automobile is only about 25% efficient in the conversion of fuel to useful kinetic energy. An electric motor is only about 25% efficient as well. To extend this somewhat further, the efficiency percentage of power plants may be expressed as usable output divided by energy available, times 100; the balance is waste of some sort or another. The waste either as heat or spent fuel residue usually has some type of environmental impact, which must be taken into consideration. The most efficient form of electric power plant is the hydro-electric plant which

may be as much as 98% efficient, unfortunately these plants only account for about 2% of the world's power. Conventional fossil fuel plants and nuclear plants are only about 40% efficient in the conversion of fuel to useful energy. Those involved in building design, construction, and operation need to be aware of these inefficiencies, since the less non-renewable energy is consumed in a building, the less will have to be produced and therefore, the less waste will be generated.

Each building has an effect on the environment. Concentrations of buildings produce an even more profound effect. Large cities absorb solar radiation, retard wind progression, and generate atmospheric pollutants which impede energy loss. This results in increased local air temperatures and may require more energy expenditure by the building's cooling system to compensate for those elevated temperatures.

In addition, the use of fossil fuels has increased the amount of carbon dioxide in the atmosphere. Carbon dioxide inhibits the radiation of long-wave radiation which produces detrimental effects on the environment. The exact effect is unknown, however, theories predict anything from complete glacial meltdown to global freezing. While the complete elimination of the use of fossil fuels is unrealistic, conservation measures may

reduce the amounts utilized, provide a longer time frame for the environment to react to absorb the waste materials generated by their use, and allow a longer period for alternate energy sources to be developed.

The earth absorbs energy from and radiates energy into space as shown by figure 1-2. There is a theoretical 'heat limit' for the earth. This limit is the maximum amount of heat rejection to the atmosphere from other sources permitted before the climate would be seriously affected. Waste heat produced when fuels are converted to energy and the energy put to work contributes a significant portion of the heat that enters the atmosphere. Energy conservation measures will prolong reaching this limit, currently projected to be in about 170 years.

Since the non-renewable energy reserves of the world, and of course, the United States, are limited, and since the U.S. leads the world in energy consumption, it is only fitting that the lead in energy conservation start here. As the underdeveloped nations raise their standards of living, the energy consumption per capita in the world will increase and therefore shorten the expected life of the energy reserves (see figure 1-3).

Buildings consume about 33% of the total national energy, using about one quarter of the national total for

space heating and water heating. There have been estimates that 50% to 80% of the non-renewable energy may be conserved in various buildings. It is therefore necessary to examine how the energy is used and conservation methods in buildings to prolong the availability of our limited national and world resources, as well as reducing the impact on the environment.

Energy Equivalents Of Various Materials

Fuels	Btu/ft ³	Btu/lb _m
Gaseous		
Methane	900	21500
Natural gas	1020	21500
Coal gas	600	13000
	Btu/gal	Btu/lb _m
Liquid		
Crude oil	138,000	19,500
Residual oil	150,000	19,000
Distillate oil	139,000	19,500
Automotive gasoline	125,000	19,300
Aviation gasoline	124,000	19,300
Diesel oil	139,000	19,500
Jet fuel (kerosene)	135,000	19,700
Liquefied petroleum gas	96,000	21,500
	Btu/ton	Btu/lb _m
Solid		
Anthracite or bituminous coal	26 × 10 ⁶	13,000
Lignite coal	13 × 10 ⁶	6,500
Wood	12-16 × 10 ⁶	6-8,000
Refuse derived fuels	10-14 × 10 ⁶	5-7,000

TABLE 1-1

(2)

Conventional Fuel Reserves

Fuel	United States		World	
	Energy (10 ¹⁸ Btu)	Time (yr)	Energy (10 ¹⁸ Btu)	Time (yr)
Petroleum	0.2	5	4	30
Natural gas	0.2	10	13	50
Coal	40	2000	400	4000

TABLE 1-2

(3)

ESTIMATED LIVES OF ENERGY RESOURCES

Consumption per year (10 ¹⁵ MJ)	Rate at indicated level	Average estimates		Lowest estimates	
		Life (years)	Date of depletion	Life (years)	Date of depletion
0.287	1974 level	250	2224 AD	32	2006 AD
—	5% growth	52	2026 AD	20	1994 AD
0.220	1970 level	326	2300 AD	42	2015 AD
0.129	1960 level	556	2530 AD	71	2045 AD
0.075	1950 level	956	2930 AD	122	2096 AD
0.029	1900 level	2474	4448 AD	316	2290 AD
0.010	1800 level	7175	9149 AD	918	2892 AD

TABLE 1-3

(4)

WORLD RECOVERABLE ENERGY RESERVES (IN 1974)

	Coal	Oil	Natural gas	Others ^(a)	Total	Reference
Estimated total world resources (10 ¹⁵ MJ equiv.)						
Highest estimates	138.0	16.0	13.0	1.7	168.7	1
Average estimates	85.0	13.0	8.0	0.6	106.6	1
Lowest estimates	32.0	11.0	4.0	0.5	47.5	1
World resources known to be extractable (10 ¹⁵ MJ equiv.)						
Highest estimates	63.0	4.0	1.8	0.7	69.5	1
Average estimates	32.0	3.8	1.5	0.6	37.9	1
Lowest estimates	3.7	3.6	1.3	0.5	9.1	1,2
Annual rate of consumption^(b) (1974) (10 ¹⁵ MJ equiv.)						
	0.086 (30%)	0.129 (45%)	0.055 (19%)	0.017 (6%)	0.287 (100%)	1, 2, 4
Equivalent continuous power rating (10 ⁷ kW)						
	38.9	58.3	24.6	7.8	129.6	
Estimate of life (years) based on 1974 consumption						
Highest estimate	1600	123	238	98	586	1, 3
Average estimate	677	65	87	35	250	1, 3, 4
Lowest estimate	43	28	24	30	32	1, 3
Estimate of life (years) based on a 5% growth in rate of usage						
Highest estimate	88	40	53	34	65	1
Average estimate	72	26	32	21	52	1
Lowest estimate	25	18	15	19	20	1

^(a) Others include uranium, shale, tarsand and other minor fossil-fuel resources. The life of uranium could be extended a hundred-fold with the development of successful safe fast-breeder reactors

^(b) World population: 3.8 · 10⁹ at 1974

TABLE 1-4

(5)

World Energy Usage Per Capita

	Index	kW/capita
United States	1.40	7.20
Canada	1.08	5.66
United Kingdom	1.00	5.24
<i>Average for industrialised nations</i>	0.95	5.00
Belgium	0.83	4.85
Australia	0.71	3.72
West Germany	0.66	3.46
Sweden	0.63	3.30
USSR	0.58	3.04
Hungary	0.50	2.62
France	0.46	2.41
Ireland	0.33	1.73
Japan	0.25	1.31
<i>Average for developing countries</i>	0.09	0.50
<i>World average</i>	0.06	0.33
Nigeria	0.04	0.21
India	0.02	0.10

Amount of energy required by man as food for basic survival:
0.15 kW/capita.

TABLE 1-5

(6)

Renewable and Nonrenewable Resources

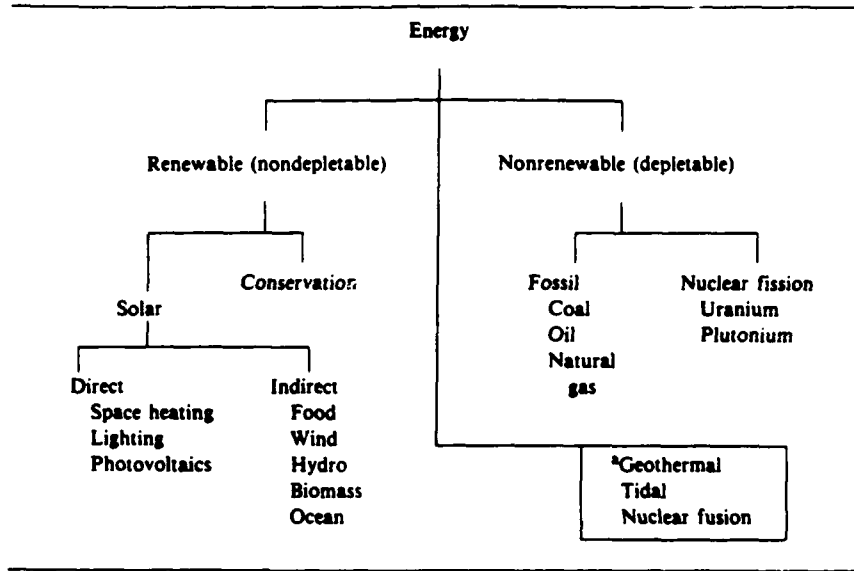

*The resources in the box can be considered as renewable or nonrenewable, depending on the system of classification.

FIGURE 1-1

(7)

Energy Flow For The Earth

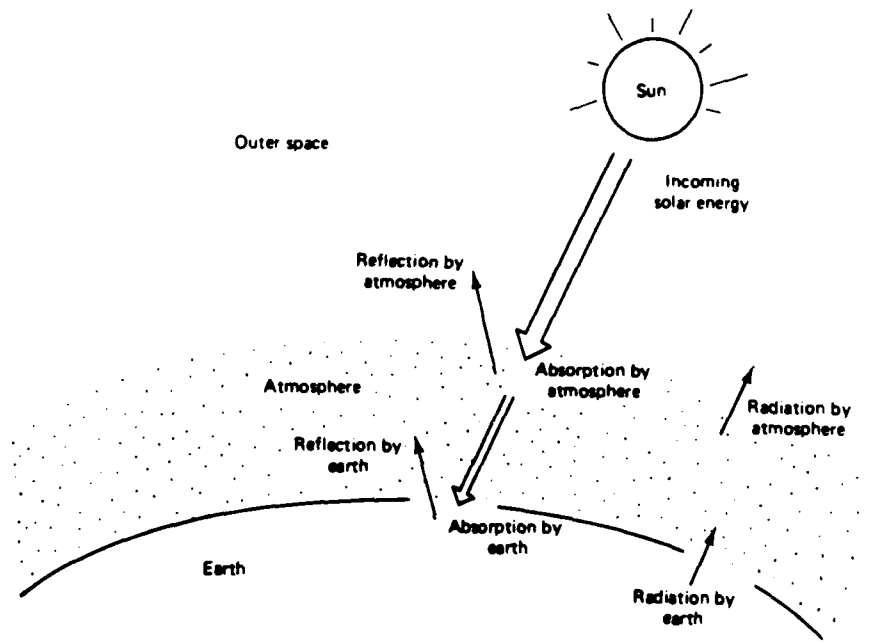

FIGURE 1-2

(8)

Projected Energy Use Per Capita

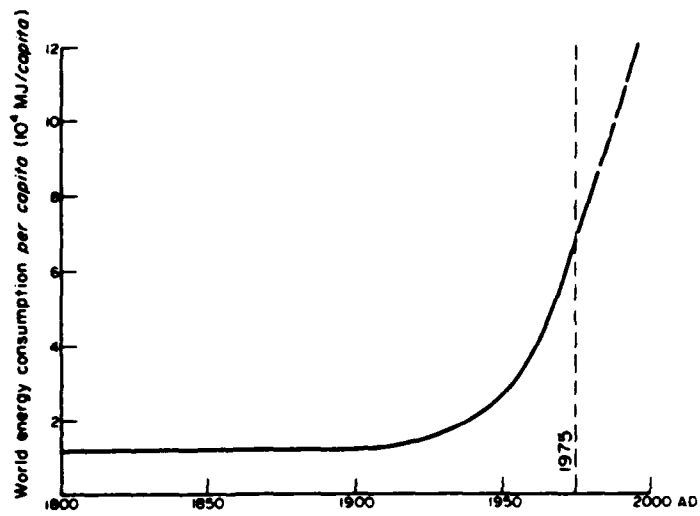

FIGURE 1-3

(9)

CHAPTER TWO
ENERGY USAGE IN BUILDINGS

When examining methods to conserve energy usage in buildings it is necessary to determine how the energy is consumed to understand the changes that are possible, as well as any limitations.

Much of the energy consumed in buildings is to maintain a thermally comfortable work environment for the occupants of the building. Thermal comfort means that the occupants are satisfied with the environment. Ideally this means that the people involved experience no heat stress or thermal strain. It is not possible to produce one set of parameters which will make all the people comfortable, because of different metabolic rates, activity levels, etc. It is, however, possible to produce a range of values to assist the designer in calculating the requirements for a particular building. The American Society of Heating, Refrigerating, and Air-conditioning (ASHRAE) has produced a chart based upon subjective test results, which shows the 'comfort zone' (figure 2-1).

People exchange energy with the environment. If the body is too warm, a heat loss will occur, if the body is too cold the body will try to absorb heat from the surrounding environment. The general equation that

describes the steady thermal state of the human body is:

$$Q_{st} = Q_m + W + Q_{ev} + Q_r + Q_c \quad (11)$$

Where Q_{st} is the thermal storage in the body. Q_{st} is set to zero to establish thermal comfort. If Q_{st} is positive or negative, heat gain or loss is taking place, and if continued to extreme conditions, the person will die. Q_m is the energy of the body. W is the work rate, which may be difficult to assess for a particular activity, however, it is available for some activities as shown in table 2-1. Q_{ev} is defined as the latent heat loss based upon body weight. Finally, Q_r and Q_c are the radiant and convective rates of heat transfer respectively.

Overall there are six primary variables which affect the comfort sensation of people. These six factors are; air temperature, radiant temperature, air velocity, relative humidity, clothing level, and degree of activity.

The body loses heat by three primary methods; convection, radiation, and evaporation. The air temperature will directly affect the body's transfer of heat by convection and indirectly affect the rate of evaporation. The radiant temperature of the surrounding

environment will control any gains or losses by radiation. Moving air will improve both the convective and evaporative heat exchange systems. Humidity becomes very important as the exterior temperature approaches that of the body. High temperatures and humidity prevent the effective operation of the body's cooling mechanisms. Clothing will affect the heat transfer mechanisms either by restricting the transfer or by protecting the body from absorbing energy from the outside environment. The thermal resistance of clothing is often expressed in units of 'clo'. A clo is equal to .88 hr ft² F/BTU. Table 2-2 lists some sample resistances of clothing. Finally, the degree of activity will determine the amount of heat that must be disposed of by the body. As shown in figure 2-2, in buildings where a high level of activity is expected the cooling capacity must be increased to a corresponding level.

In addition to generating sensible heat people also generate latent heat, that is the heat added as moisture through breathing and perspiration. An average adult in a room at normal temperatures will lose about 75W of sensible heat and about 25W of latent heat or a total of about 100W. Table 2-3 shows the metabolic rates as sensible and latent heat generated for different activities.

Lighting is another major use of energy in a building. The costs of lighting a building may be quite high, both in monetary and energy consumption terms. Lighting generates heat which must then be removed by the air conditioning. Illumination consumes about 2% of the national energy budget and about 15% of the total amount of electricity produced.

Light on a surface is measured in footcandles/square foot. The amount of illumination that must be produced by a lamp to provide a specific level of illumination is given by:

$$\text{lamp lumens} = (\text{footcandles})(\text{area})/\text{coefficient of utilization}$$

The coefficient of utilization is a complex function which accounts for the conversion of light at the surface of the light to the illuminated surface. Table 2-4 shows the recommended lighting levels for different environments.

The amount of energy required to provide a given amount of illumination is determined by:

$$A/\text{square foot} = \text{Footcandles}/(B)(C)$$

where:

- A = electrical energy
- B = lumens/watt
- C = coefficient of utilization

The amount of electricity used in the generation of light will depend on the type of lamp. An incandescent

lamp only renders about 10% of the energy consumed as visible light. A fluorescent lamp, on the other hand, only consumes about 25 % of the energy utilized by an incandescent lamp to produce the same amount of light.

When an owner and/or designer contemplate construction of a new building it is imperative that adequate consideration be given to the purposes for which the building is to be or may be used. This will allow the selection of the correct environmental and lighting systems for the structure. If the environmental system is not adequate, production losses may occur, as well as the circumventing of the energy conservation measures in effect. This will result in wasted energy and/or escalating operating costs.

ASHRAE Comfort Standard

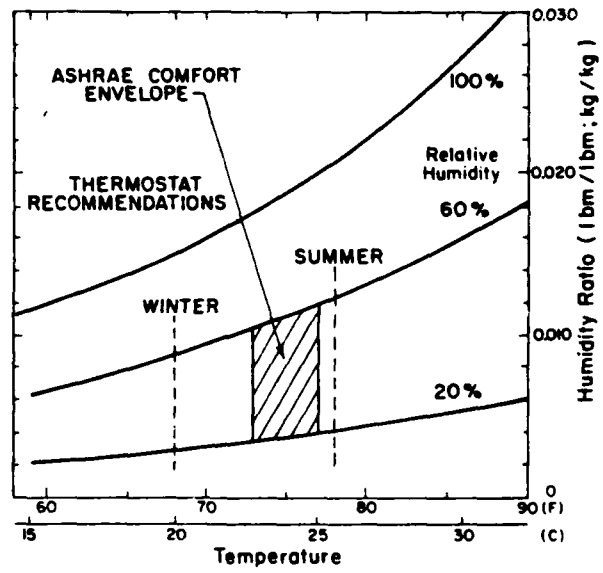

ASHRAE comfort standard.

FIGURE 2-1

(10)

METABOLIC RATES FOR DIFFERENT ACTIVITY LEVELS

Activity	Rate of heat production (W m ⁻²)	Activity	Rate of heat production (W m ⁻²)
Sleeping	40	Machine work	100-260
Seated quiet	60	Shop assistant	120
Walking (3 mph)	150	Teacher	90
Light work	120	Vehicle driving	80-180
Medium work	170	Domestic work	80-200
Heavy work	300	Office work	60-80
Heaviest work possible	450-500		
Carpentry	100-370	Tennis	200-270
Foundry work	170-400	Squash	290-420
Garage work	80-170	Wrestling	400-500
		Golf	80-150

NB—The average body area is approximately 1.8 m² [24].

TABLE 2-1

(12)

Thermal Resistance of Clothing

Dress	R Value	
	(clo)	(hr ft ² °F/Btu)
Women		
Cool dress	0.20	0.18
Warm dress	0.50	0.44
Pantsuit	0.60	0.53
Dress, overcoat	1.10	0.97
Men		
Long pants, short sleeve shirt	0.45	0.40
Business suit	1.0	0.88
Suit, overcoat	1.5	1.30

TABLE 2-2

(13)

Cooling Capacity vs Activity level

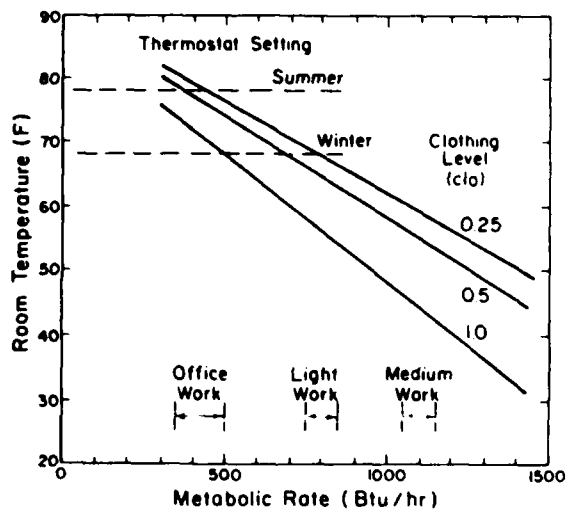

FIGURE 2-2

(14)

Sensible and Latent Heat Flows for People

Activity Level	Sensible Heat Flow (Btu/hr)	Latent Heat Flow (Btu/hr)	Total Heat Flow (Btu/hr)
Seated	210	140	350
Office work, light	230	190	420
Office work, medium	255	255	510
Light work	375	435	810
Medium work	345	695	1040
Heavy work	565	1035	1600

TABLE 2-3

(15)

Recommended Illumination Levels

Area	IES (fc)	GSA (fc)
Office - Drafting areas	200	-
General offices	70-150	50
Conference Rooms	30	30
Hallways	20	10

TABLE 2-4

(16)

FC = FOOTCANDLES

CHAPTER THREE

ENERGY LOSSES IN BUILDINGS

A building exchanges energy with the environment. It either absorbs or dissipates energy. Ideally the exchange will be minimal and maintain the appropriate working environment for the occupants.

Building heat losses occur through conduction, convection, and radiation. These losses are transferred through the floors, windows, doors, walls, roofs, HVAC make-up, and through a process called infiltration. Infiltration losses are those losses which occur as a result of air flow through various cracks and unsealed openings in the building. Figure 3-1 provides a representation of these flows from a building. These losses may be calculated and expressed as follows:

$$q(\text{loss}) = UAt(T_r - T_a) + q(\text{bt}) \quad (18)$$

Where UAt is the overall conductance-area product for the building. T_r is the interior temperature and T_a is the ambient Temperature. In addition, $q(\text{bt})$ is the heat loss through the floor. The term UAt is the summation of terms for individual losses in the walls, doors, roof, windows, HVAC make-up, and infiltration and may be expressed as shown:

$$UAt = UA_{wl} + UA_{dr} + UA_{rf} + UA_{wd} + UA_{hvac} + UA_{inf}$$

Figure 3-2 shows a schematic representation for the analysis of heat transfer through a wall. By knowing the thermal properties of the various building materials the designer will be able to more effectively calculate the energy losses to be expected. It may then be possible to substitute a material with superior energy efficient qualities and produce similar aesthetic effects.

Windows are a luxury if viewed from the stand point of heat loss. The typical heat loss may be calculated as shown below:

$$Q_{wd} = U A_{wd} (T_r - T_a) \quad (20)$$

Table 3-1 shows some typical conductance values for windows. The use of double pane windows may reduce the heat loss by 50% and the addition of another pane will produce another 10%-15% savings.

Heat losses due to infiltration comprise another major energy waste area. As the difference between the room temperature and the ambient temperature increase so do the losses associated with infiltration. The best way to deal with these losses is to eliminate unnecessary drafts and 'tighten' up the building. It is, however, necessary to provide sufficient new air (either by infiltration or preferably by direct induction via the HVAC make-up) to provide the occupants with a safe breathable atmosphere.

Once the designer has taken into account the heat losses, it is then necessary to consider heat gains in the building. Figure 3-3 provides a representation of the heat gains in a building. Heat gains are calculated using energy sources other than the furnace. The number of personnel and the activity level are taken into account. Appliances, equipment, lighting, and other heat generating items are tabulated. Dehumidification and any process influences are accounted for. And finally, the heat gain through the windows and exterior structure are calculated. Using this information the designer then selects the appropriate sized air conditioning and heating systems for the structure.

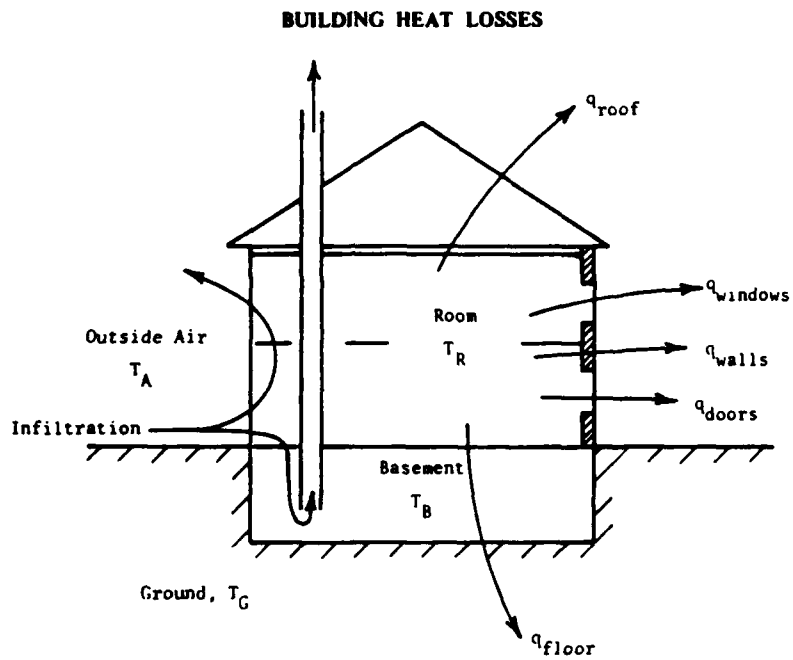

Schematic of heat flows from a building.

FIGURE 3-1

(17)

Heat Transfer Through A Wall

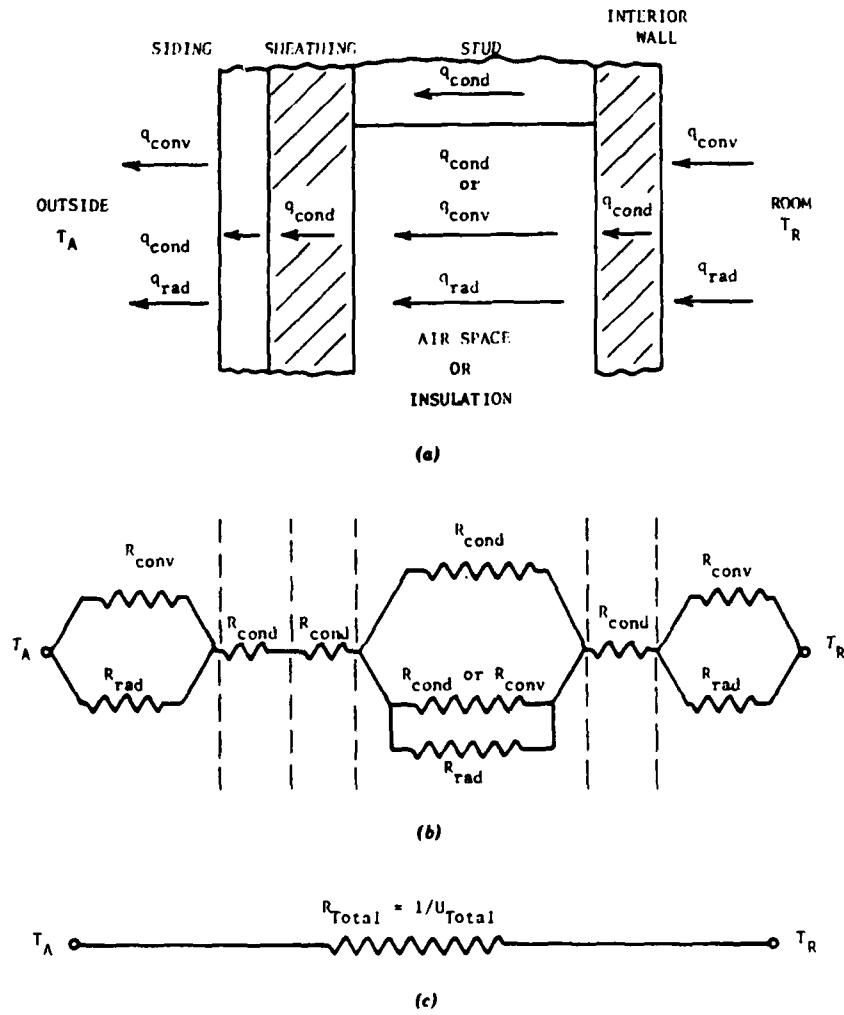

Heat transfer analysis for a frame wall. (a) Schematic of heat flows in a wall. (b) Thermal circuit for heat flow. (c) Equivalent thermal resistance.

FIGURE 3-2

(19)

Conductance Values for Windows

	<i>U</i> (Btu/hr ft ² °F)	
	Winter	Summer
Single glazing	1.13	1.06
Double glazing, ¼-in. space	0.65	0.61
Double glazing, ½-in. space	0.58	0.56
Double glazing, 1-4-in. space	0.56	0.54
Triple glazing, ¼-in. space	0.47	0.45
Triple glazing, ½-in. space	0.36	0.35

TABLE 3-1

(21)

Heat Gains To A Building

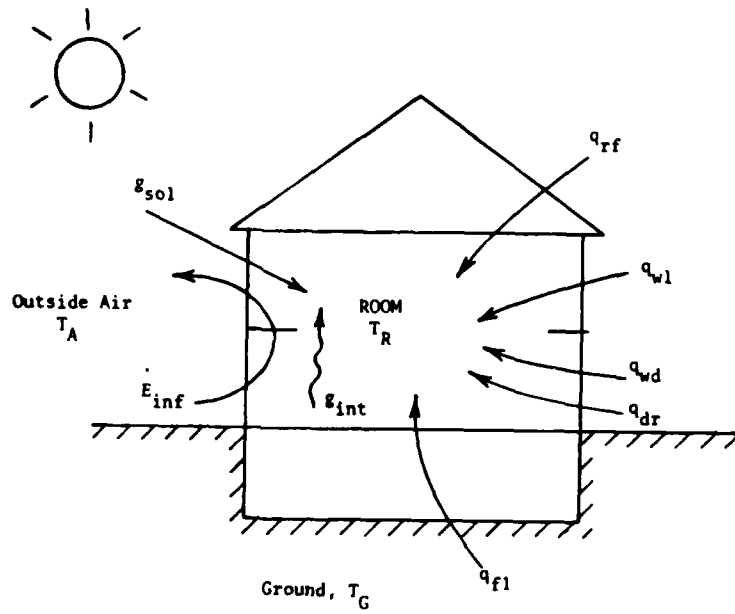

Schematic of heat gains in a building.

FIGURE 3-3

(22)

CHAPTER FOUR

CLIMATIC EFFECTS AND CONSIDERATIONS

In the days of inexpensive and inexhaustible energy supplies American buildings were constructed with little regard for energy efficiency. There was also little regard for the climatic conditions available to assist in maintaining the desired environment in the building.

As a general rule a structure is erected to maintain a particular set of environmental conditions. This 'sheltering' from the outside climate has resulted in the acceptance of a comfort range in the U.S. which peoples from other nations find either much too cold in the summer, or much too hot in the winter. While it is necessary to provide protection from the extremes of the weather, most of the U.S. is within temperature zones, as shown by figure 4-1. This would allow people to remain comfortable most of the time, if the building were constructed to make use of the prevailing conditions.

The climate of the States has been studied intensively, officially starting in 1870 by the Weather Bureau (then the Division of Telegrams and Reports for the Benefit of Commerce, Signal Corps, U.S. Army). Prior to 1870 private citizens studied the climate, and in some cases temperature and rainfall data are available as far back as 1758. Currently, hourly readings are being taken

in many major cities and include such data as; temperature, wind speed, wind direction, humidity, rainfall, and solar intensity.

While the effects of weather on heating and cooling loads are well understood, the information is most frequently used only to select the size of the heating or cooling unit for the building. The information should also be used to determine what role the climate could play in supporting the heating and cooling requirements of a building.

When designing to fit into a particular climate, the designer must first identify all the liabilities and assets available in that particular climate. Any type of energy conscious design is dependent upon the regional variations in temperature, humidity, wind, and solar exposure time. The building should then be designed to utilize the assets and close out the liabilities. An asset in one climate may be a liability in another, therefore, it is necessary to avoid arbitrarily constructing a building in one climate that was designed to function in another.

A climatic liability in an area is one that will make seasonal conditions worse. For example, the temperature may be a liability in both hot and cold climates when it is consistently too hot or cold. Wind, in cold climates,

is generally considered a liability since it tends to remove heat quickly. The wind may also be a liability in hot dry climates by causing dehydration. The sun is generally a liability in hot climates. High humidity may be a problem in warmer climates because it will interfere with the body's evaporative cooling mechanism.

A climatic asset is one that makes the seasonal conditions better. Diurnal temperature variations may be utilized to provide an even temperature throughout the day by building with heavy materials which absorb and dissipate energy slowly. The wind may be an asset, providing natural ventilation. The sun may provide passive heat in cooler climates, thus becoming an asset in those areas. And even the moisture content of the air may be an asset in dryer climates by allowing the evaporation of moisture and acting as a natural air conditioning system. The use of these climatic assets offers methods of replacing dependence on depletable energy sources with non-depletable sources.

In addition to the effects of the climate, owners and designers must pay attention to the actual site selection for the structure. Shielding a building behind a hill may prevent losses associated with high winds. Placing a building in a small wind gully may assist in cooling the

structure. It is even possible to use heat reflected from water to provide additional energy to a building.

Ground cover and trees along with artificial channeling structures may be used to guide air currents and protect from the sun's intensity. However, in a high humidity environment those plants producing excessive moisture should not be placed where that moisture may be carried into the building.

Figures 4-2 through 4-6 show the charts produced as part of the preliminary process for the determination of the requirements for a particular climatic area. In this case the data is for Miami, Fl.

When designing a building, the designer must examine methods to make the building blend into the environment, using the assets and minimizing the liabilities, instead of trying to combat it.

Heating And Cooling Zones For The U.S.

Heating zone data

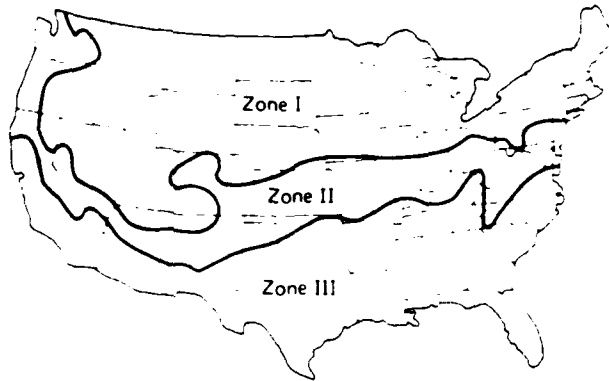

Heating zones Zone	Temp diff (TD)*	Degree days (DD)
I	80	8000
II	70	5500
III	50	3000

*Assume 70° F indoor temperature.

Cooling zone data

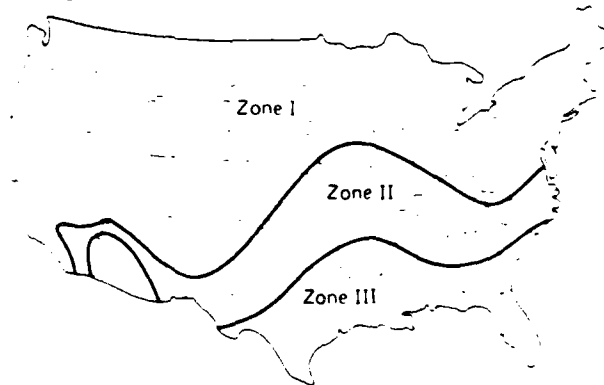

Cooling zones Zone	Cooling hours (hr) / YEAR
I	500
II	1000
III	1500

FIGURE 4-1

Basic Climate Condition — Comfortable What Are Your Climate's Assets and Liabilities?

Climate and comfort are not purely a function of temperature and humidity. The effects of solar radiation, wind, moisture addition, and diurnal temperature ranges can significantly improve (or jeopardize) individual and room comfort. (All data in the graphs are for Miami, FL.)

THE BASIC CONDITION: TEMPERATURE AND HUMIDITY

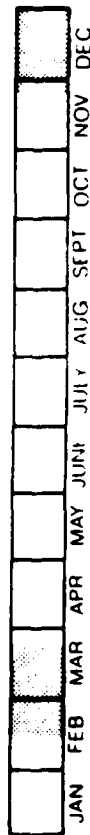

TEMPERATURE AND HUMIDITY
(increases comfortable periods)

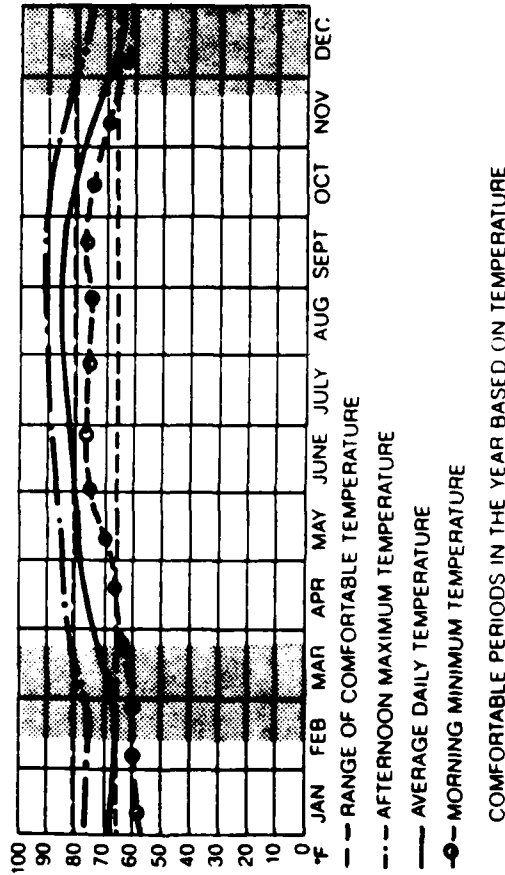

1. TEMPERATURE: AN ASSET

The major asset of this climate is that temperatures are mild for most of the year. The designer's and builder's job, under these circumstances, is not to reduce the comfortable period by letting sun, wind, or humidity become liabilities.

THE BASIC CONDITION: TEMPERATURE AND HUMIDITY



TEMPERATURE AND HUMIDITY PLUS SOLAR HEAT GAIN
(decreases comfortable periods)

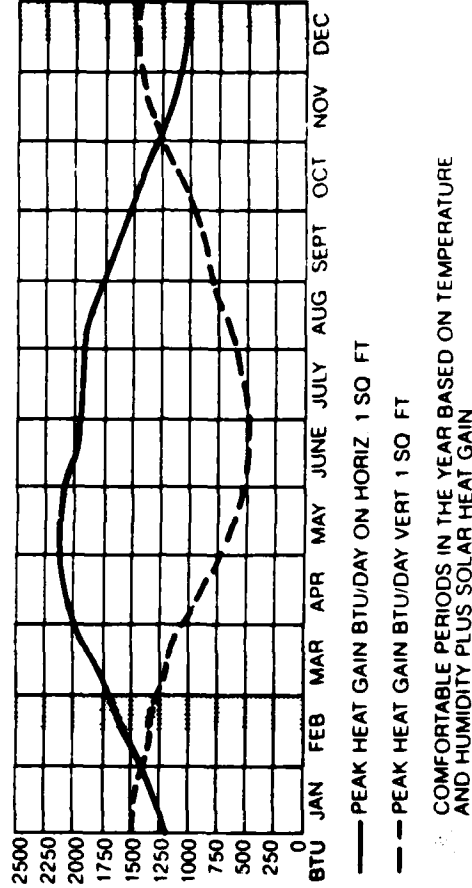

2. SUN: A LIABILITY WHEN IT'S TOO HOT FOR COMFORT

In this gentle climate uncontrolled exposure to solar radiation can cause significant cooling loads and severely reduce the amount of natural comfort available. Proper design can shield interiors from overheating when temperatures are comfortable and even provides comfort when it is too cool.

THE BASIC CONDITION: TEMPERATURE AND HUMIDITY

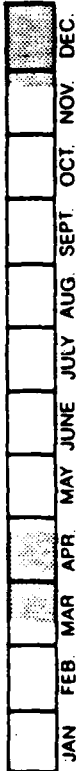

**TEMPERATURE AND HUMIDITY PLUS WIND
(increases comfortable periods)**

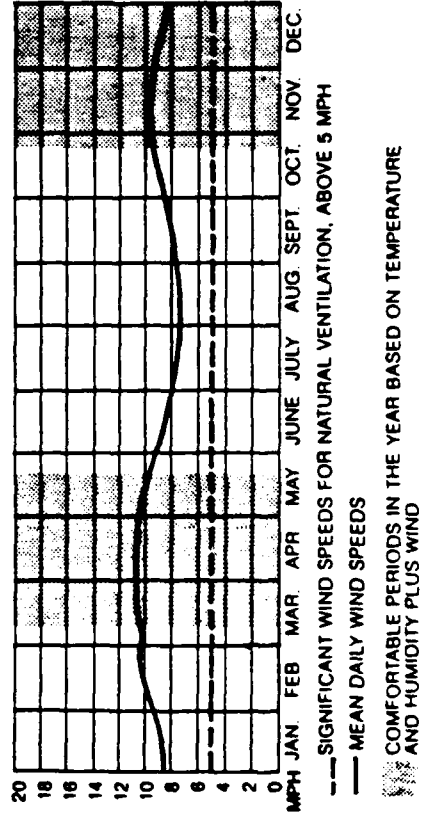

3. WIND: AN ASSET WHEN IT'S TOO HOT FOR COMFORT

In this climate, winds can contribute to comfortable living by increasing evaporative heat loss from the human body. Taking advantage of the ocean winds for controlled ventilation, the periods of natural comfort can be extended throughout the warmer months, eliminating the need for mechanical air conditioning.

THE BASIC CONDITION: TEMPERATURE AND HUMIDITY

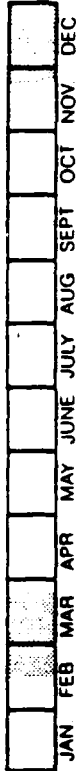

**TEMPERATURE AND HUMIDITY PLUS MORE HUMIDITY
(decreases comfortable periods)**

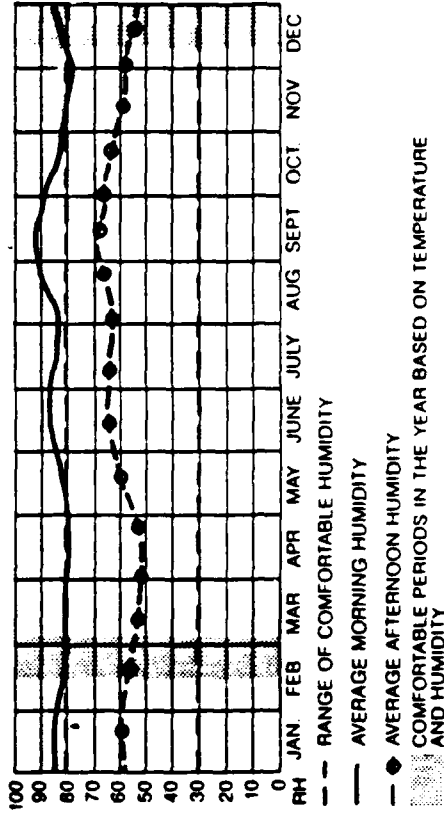

4. MOISTURE: A LIABILITY WHEN IT'S TOO HOT FOR COMFORT

Humidity significantly reduces the comfort period. The poor placement of fountains, pools, plants and other moisture-producing elements can increase the relative humidity and decrease the periods of comfort. Dehumidification in this region is an effective cooling measure, with natural ventilation one way of achieving this.

THE BASIC CONDITION: TEMPERATURE AND HUMIDITY



TEMPERATURE AND HUMIDITY PLUS SOLAR HEAT GAIN
(Increases comfortable periods)

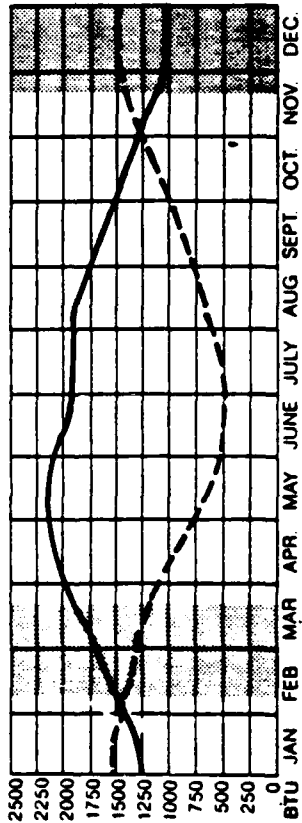

— PEAK HEAT GAIN BTU/DAY ON HORIZ. 1 SQ. FT.
 - - - PEAK HEAT GAIN BTU/DAY VERT. 1 SQ. FT.
 COMFORTABLE PERIODS IN THE YEAR BASED ON TEMPERATURE AND HUMIDITY PLUS SOLAR HEAT GAIN

5. SUN: AN ASSET WHEN IT'S TOO COOL FOR COMFORT

For a portion of the year—at night and on some days—it is too cool for comfort. This condition can easily be compensated for in winter by capturing the sun that enters the house and by storing its heat.

THE BASIC CONDITION: TEMPERATURE AND HUMIDITY



TEMPERATURE
(decreases comfortable periods)

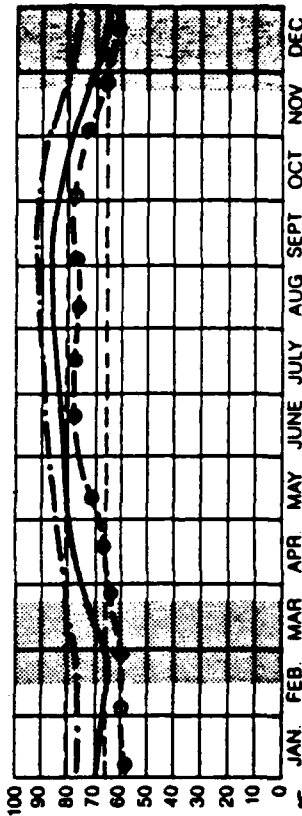

— RANGE OF COMFORTABLE TEMPERATURE
 - - - AFTERNOON MAXIMUM TEMPERATURE
 — AVERAGE DAILY TEMPERATURE
 - - - MORNING MINIMUM TEMPERATURE
 COMFORTABLE PERIODS IN THE YEAR BASED ON TEMPERATURE

6. TEMPERATURE: A LIABILITY

When it is below 65°F or above 80°F, outside temperatures are a liability to human comfort and require positive methods of compensation. Building for good ventilation and dehumidification (for cooling) in summer, and capturing the sun and reducing exposure (for heating) in winter will promise comfortable living throughout the entire year and minimize the use of fuel-consuming mechanical systems.

Sample Preliminary Design Preparations Summary

FIGURE 4-6 (28)

TOO HOT FOR COMFORT	TEMPERATURE	WIND	MOISTURE	SUN	TEMPERATURE	WIND	MOISTURE	SUN
	<input type="checkbox"/>	<input type="checkbox"/>	<input checked="" type="checkbox"/>	<input type="checkbox"/>	<input type="checkbox"/>	<input type="checkbox"/>	<input checked="" type="checkbox"/>	<input type="checkbox"/>
TOO COOL FOR COMFORT	TEMPERATURE	WIND	MOISTURE	SUN	TEMPERATURE	WIND	MOISTURE	SUN
	<input checked="" type="checkbox"/>	<input type="checkbox"/>	<input type="checkbox"/>	<input type="checkbox"/>	<input type="checkbox"/>	<input type="checkbox"/>	<input type="checkbox"/>	<input type="checkbox"/>
COMFORTABLE	LIABILITIES				ASSETS			
	<input type="checkbox"/>	<input type="checkbox"/>	<input type="checkbox"/>	<input type="checkbox"/>	<input checked="" type="checkbox"/>	<input type="checkbox"/>	<input type="checkbox"/>	<input type="checkbox"/>

Summary

Because up to 80% of the year is thermally comfortable, it is most important that building designs do not jeopardize the natural comfort offered. With good design, 100% passive, non-mechanical comfort can easily be achieved.

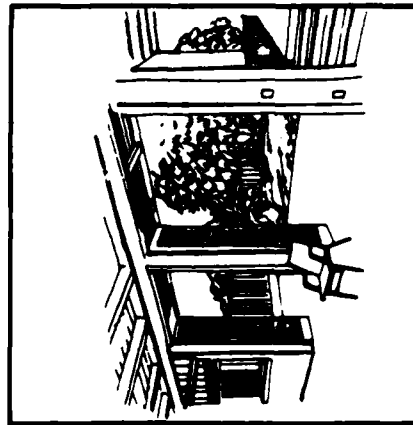

1 BUILD FOR EXPOSURE TO THE PLEASANTNESS OF A COMFORTABLE CLIMATE
Fifty to eighty percent of the year is comfortable outside

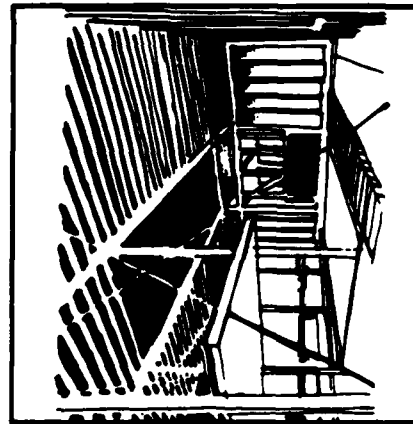

2 KEEP OUT THE SUN. Solar heat gain is a liability most of the year, causing unnecessary overheating. Extensive roofing provides sun protection and shaded outdoor living spaces

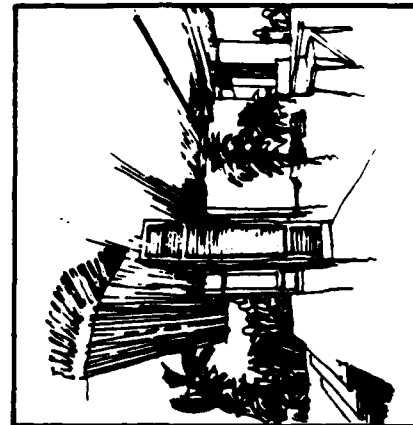

3 ALLOW WINDS TO VENTILATE AND COOL. Use pavilion-like, open plan buildings to maximize air movement. Louvered, shuttered, or hinged walls allow for excellent cross ventilation

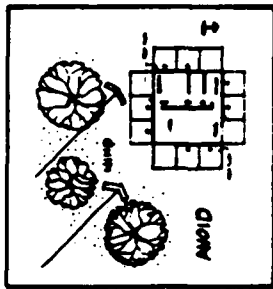

4 AVOID CREATING ADDITIONAL HUMIDITY



5 LET THE SUNLIGHT IN AT SELECTED TIMES

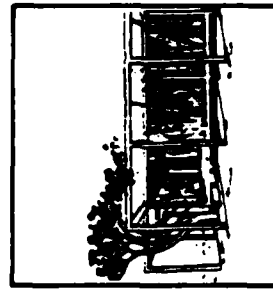

6 AVOID EXPOSURE TO OUTSIDE TEMPERATURES WHEN IT'S TOO HOT OR TOO COOL FOR COMFORT

CHAPTER FIVE

IMPROVING THE EFFICIENCY OF BUILDINGS

The efficiency of a building may be improved in numerous ways. The designer must weigh the cost of each method against the overall life cycle cost. Some of the methods lend themselves to installation in older structures, while others are only cost effective when installed in a new building. Ideally the energy efficiency should be built into the building with minimal reliance on the occupants of the building to achieve the desired results. While the general public is learning to conserve energy, the actions of the occupants of a building are not as easily controlled as a built in system. As was previously discussed the designer should attempt to reduce infiltration losses and utilize the climate to achieve the environmental goals of the structure. In addition the designer should examine the costs of added insulation, improved lighting systems, improved windows, and optimize the mechanical systems. Finally, the designer should take an overall total system approach when possible, including heat recovery systems, computer controlled environmental systems, and the examination of possible alternate sources for low grade energy.

Part A - INSULATION

As earlier discussed, a building loses and gains energy from the local environment. Reduction of these losses will improve the energy efficiency of the building and result in a greater level of conservation as well as reduced operating costs.

The insulating ability of a material is stated as an 'R' value. The 'R' value is the resistance to energy flow, which is the inverse of the conduction of energy or 'U'. R is equal to one divided by U. R values tend to be easier to manipulate since they are generally greater than one for an insulating material, while the U values are a small decimal number. Table 5-1 shows the R value of some typical building materials.

The insulation of buildings is based on the fact that dry still air is not a good conductor of heat, therefore, insulating material traps the maximum amount of dry air in small pockets. Three common forms are the glass fibers in the shape of mats, rock minerals formed into fluffy masses, and some form of rigid plastic foam. These are placed in walls, under floors, in ceilings and any other location where the movement of heat must be minimized. Table 5-2 shows the effect of adding insulating material to a wall.

It is theoretically possible to insulate a building to allow a minimal amount of unwanted heat transfer. There are, however, practical matters to be considered. As more insulation is added, the cost of the building increases. An owner must then calculate the cost of increased insulation and that of the expected cost of energy use for the various levels of insulation. It is then necessary to calculate the minimum cost of insulation and energy usage over the lifetime of the building. These projections and calculations should generate a chart similar in form to figure 5-1. When projecting the expected energy costs an owner should examine the expected increase in energy costs over the lifetime of the building. However, with the energy market and future of the energy market in such a state of flux, this may be more difficult than it first appears. Many energy specialists believe that building owners underestimate the future costs of energy and therefore install less insulation than required. This may be particularly true in the case of short term owners, whose intentions are to sell a building after utilizing it for a short period of time. In this case the buyer should ask to examine the energy usage records and future projections of use and cost.

In addition, the correct amount of insulation for a building requires a detailed knowledge of the climatic conditions.

Insulation may also be installed in existing buildings, particularly those of a smaller size (including houses). In many cases this installation is easily performed and has a short payback period.

PART B LIGHTING

The costs that are associated with lighting may be reduced by the use of more energy efficient lamps and the reduction of lighting levels to those recommended by Illumination Engineering Society or the Government Services Administration. The reduction of the lighting levels saves energy in the direct production of light as well as the indirect costs associated with the removal of the heat generated by the lights. As a general rule it is not economical to use incandescent lighting in commercial buildings, because of energy usage and lamp life. There are various low energy lighting systems available which the designer must be aware of when designing a building to minimize the energy usage. In addition, experiments are being conducted to utilize solar energy to provide lighting for building. Such an option would significantly reduce the energy usage in this area.

PART C WINDOWS

Windows allow a considerable amount of energy to escape from a building. Although, those windows currently in use are far more efficient than their predecessors. The use of double paned windows significantly reduces the energy loss and the addition of special coatings further reduces energy loss. In the near future windows may achieve the insulating equivalent of a standard 2x4 insulated wall (R-10) by the use of aerogel fillers. Aerogels are silica gels that are dried by a process that leaves a material that is about 95% air. Figure 5-2 shows a comparison of the thermal conductance properties of the various window types. In addition to the aerogel research, several laboratories are working on an electrochemic glass which will make windows more controllable. The electrochemic glass changes between a clear state and a dark blue or bronze state by the application of an electric field. This type of window does not insulate as well as an aerogel window but may be utilized in glare control. Another drawback to the electrically controlled window is the expense, which is currently over \$100.00 per square foot. As these costs decrease it may be possible to utilize both new forms of window together.

PART D MECHANICAL SYSTEMS

The selection of the appropriate mechanical system to provide the heating for water and air, ventilation, and air conditioning may be of the utmost importance. In older buildings substituting more efficient equipment is frequently one of the easiest methods to reduce energy consumption. Tables 5-3 and 5-4 show the energy use by function by building type. There is a great potential for the development of more efficient mechanical systems in these areas. When a building is in the design phase the designer must examine the various systems available to install the most efficient and cost effective one available. If possible the designer should make provision for the future changing of the equipment as more efficient systems become available. Smaller systems and appliances are required to be labeled by the Energy Policy and Conservation Act, however, larger commercial items are not covered and may require some research by the designer to determine the correct system for the building. For example it may be possible to utilize heat pumps instead of a furnace and an air conditioning system.

PART E TOTAL SYSTEM DESIGN

In any building design the designer should examine the total system energy requirements. Energy is graded, the higher the grade, the more useful the energy. Using high grade energy to perform the work of low grade energy is not an efficient use of energy. When possible, waste energy from a higher grade should be used to provide the needs normally supplied by a lower grade. Large industrial complexes may be able to utilize co-generation and waste heat recovery systems that are not practical on smaller buildings. It may be possible to utilize an alternate source, such as solar heating, for many of the low grade energy requirements.

A designer must also examine the various computer controlled systems available and if possible should make provisions for the future installation of such a system should that option not be initially included in the building. Such systems may provide considerable savings in energy as they can monitor numerous factors throughout the structure and make adjustments automatically to conserve energy. Finally the designer must examine developments in new building materials which may conserve energy as well as installation costs, and examine more efficient methods of utilizing space to allow for a possible reduction in the size required by a structure.

R Values of Typical Building Components

Material	<i>R</i> Value ^a
Wood (per inch)	1.2
1/2-in. plywood	0.6
Building paper	0.1
Lapped bevel siding (wood)	0.8
Shingles (wood)	0.8
Stucco (per inch)	0.2
Fiberboard sheathing (1/2 in.)	1.2
Concrete (per inch)	0.0
Brick (per inch)	0.2
Gypsum board (1/2 in.)	0.4
Carpet with fiber pad backing	2.0
Carpet with foam rubber padding	1.2
Extruded polystyrene sheathing (1/2 in.)	2.5
Vermiculite, loose fill (per inch)	2.0
Perlite, loose fill (per inch)	2.7
Fiberglass insulation (per inch)	3.3
Rock wool (per inch)	3.3
Polystyrene rigid board (per inch)	3.4
Cellulose fill (per inch)	3.7
Urethane foam (per inch)	5.3
Urea formaldehyde foam (per inch) ^b	4.5
Isocyanurate rigid insulation	7.0

^aTo convert these *R* values to the *R* values used in the Systeme International, multiply by 0.176. Thus the *R* value of wood is $1.25 \times 0.176 = 0.22 \text{ m}^2 \times \text{degree Celsius per watt}$.

^bNot recommended because of toxic vapors

TABLE 5-1

(29)

Effect on R Values of Adding Insulation to a Wall

	Wall Without Insulation	Wall With R-11 Insulation
Outer layer (air film, siding, building paper, sheathing)	R-2	R-2
Enclosed air space	R-1	R-0 ^a
Insulation	R-0	R-11
Inner layer of wall (interior wall material, air film)	R-1	R-1
Total	R-4	R-14
Wall heat flow value ($U=1/R$ total)	$1/4=0.25$	$1/14=0.07$

^aAir space not credited to insulated wall because it has been replaced by the insulating material.

TABLE 5-2
(30)

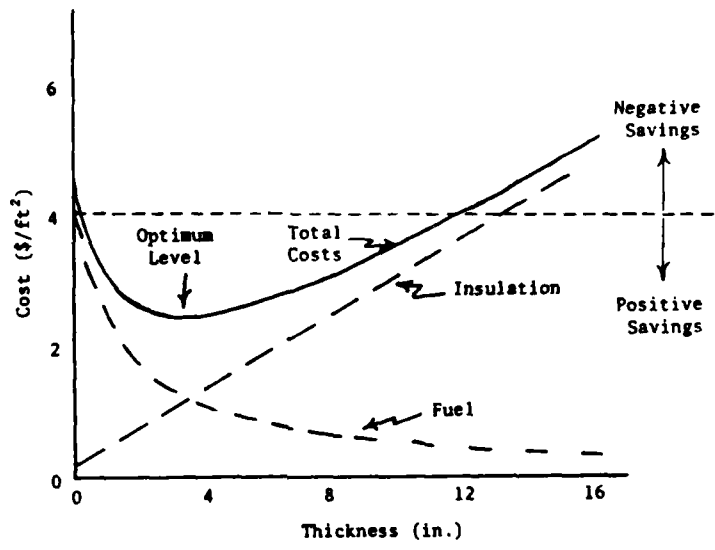

Costs of insulation as functions of thickness.

FIGURE 5-1

(31)

Thermal Conductance Of Various Window Types

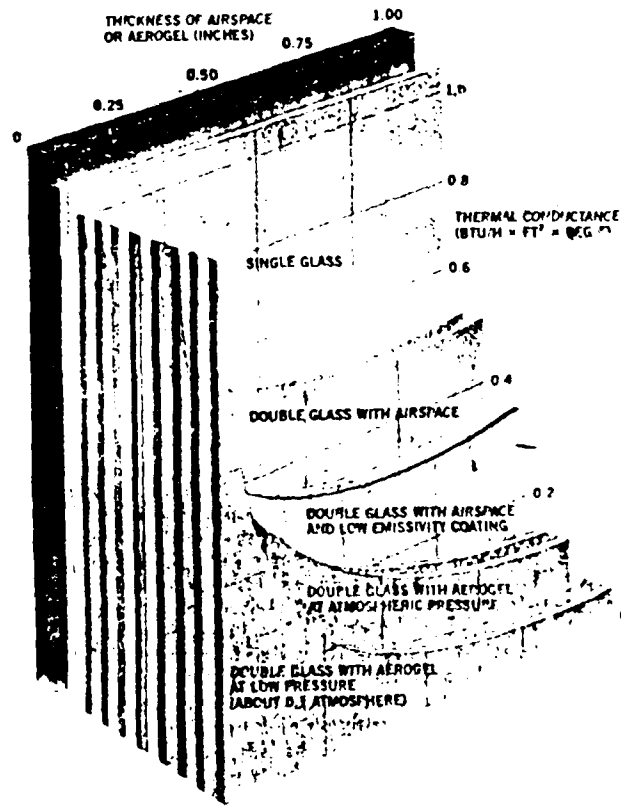

FIGURE 5-2

(32)

Energy Use by Function and Building Category.

Building Category	Space Heating		Air Conditioning		Water Heating		Lighting		Other		Total Quadrillion BTUs
	Quadrillion BTUs	Percent	Quadrillion BTUs	Percent	Quadrillion BTUs	Percent	Quadrillion BTUs	Percent	Quadrillion BTUs	Percent	
Stores	0.996	45.3	0.536	24.4	0.108	4.9	0.455	20.7	0.108	4.8	2.201
Schools	1.139	61.7	0.137	7.4	0.174	9.4	0.335	18.1	0.081	3.3	1.846
Supermarkets	0.495	50.4	0.073	7.4	0.050	5.1	0.149	15.2	0.216	21.9	0.982
Hospitals	0.450	51.7	0.144	16.2	0.127	14.3	0.061	5.7	0.108	12.1	0.890
Offices	0.433	49.4	0.179	20.4	0.041	4.7	0.149	17.0	0.075	8.6	0.877
Hotels	0.359	53.3	0.107	15.9	0.066	9.8	0.105	15.6	0.036	5.3	0.673
Colleges	0.345	60.1	0.076	12.6	0.042	10.8	0.072	12.5	0.017	3.0	0.574
Other	0.708	62.2	0.059	5.2	0.142	12.5	0.146	12.8	0.084	7.4	1.139
Subtotal (nonresidential)	4.935	53.7	1.313	14.3	0.770	8.4	1.482	18.9	0.702	7.8	9.192
Apartments	1.649	57.5	0.105	3.7	0.429	15.0	0.141	4.9	0.545	19.0	2.869
Total	6.584	54.6	1.418	11.8	1.199	9.9	1.603	18.3	1.247	10.3	12.051

Source: National Petroleum Council, Potential For Energy Consumption in the United States: 1974-1978 Residential/Commercial, table 21, p. 61, recalculated to show percentages and to total certain figures disaggregated in original source.

TABLE 5-3

(33)

Household Energy Use by Function.

	<i>Percent usage</i>
Space heating	55.1
Water heating	15.0
Cooking	4.8
Clothes drying	2.2
Refrigeration	6.7
Air conditioning	5.4
Other (including lighting)	10.8
	100.0

Source: National Petroleum Council, *Potential for Energy Conservation in the United States: 1974-1978: Residential/Commercial* (Washington, D.C.: National Petroleum council 1974), p. 6, citing Stanford Research Institute data, adjusted.

TABLE 5-4

(34)

CHAPTER SIX
ALTERNATE SOURCES

In recent years much attention has been given to the development of alternate energy sources. Alternate energy sources are those sources that will replace the conventional fossil fuels and other depletable resources. Numerous sources exist, the more prominent being; fusion, breeder reactors, wind, waves, tides, solar geothermal, and the earth. In addition, many advances have been made in the conversion processes of conventional fuels. Unless the designer is working in one particular area or with a very large project most of these advances will have minimal impact on a building.

There is, however, one source that may provide excellent low grade energy for most structures, particularly those of a smaller size, and that source is the sun. In fact, the sun may be considered as the source of almost all the energy on the earth as shown in figure 6-1. In addition, in some isolated areas the wind and the earth may provide enough energy to augment some energy requirements of buildings.

In any building design the lowest grade of energy possible for a given requirement should be utilized. Electricity is a high grade of energy frequently used for space and water heating that could be provided by another energy source.

The amount of usable solar energy reaching the earth's surface equates to about 561 billion barrels of crude oil per day. Solar energy is readily available in the U.S., figure 6-2 shows the average amount available in terms of Btu/square foot. The conversion of solar energy to low grade heat is accomplished at reasonable costs. The conversion of solar energy to high grade energy in the form of electricity is still very expensive.

Photovoltaics currently cost about \$10.00-\$15.00 per peak watt. Besides the cost, the only other drawbacks may be the area required for the conversion process, and the fact that they do not work at night. Photovoltaics are clean, reliable, do not pollute the environment, and do not produce waste heat in the conversion process. If photovoltaics were utilized to produce the entire electrical requirements for the U.S., an area of approximately 6,500 square miles would be required. This is only about .18% of the total land area of the country.

The primary use of solar energy in the U.S. is for space heating. Solar space heating systems are either active, passive or hybrid. Active systems require the addition of external energy to function. A passive system uses only the architectural design to move and store the energy. A hybrid system does not use any external energy,

but uses mechanical devices, such as fans and small pumps, to move the energy.

A passive solar system employs a design that frequently uses movable insulation to provide the required level of heat. Opening the curtains on the sunny side of a building to admit the sun's warmth is such a system (see figure 6-3).

An active heating and cooling solar system employs four major parts to accomplish the desired effect (see figure 6-4). The first portion is the collector. The collector intercepts the solar radiation and converts it to heat for transfer to the storage unit or to the heat load. A solar collector may be a flat plate type of collector or a concentrating collector (see figure 6-5 and 6-6). The concentrating collector generally heats liquids, while the flat plate collector may be used to heat either liquids or air. As a general rule the concentrating collector is more expensive to construct and operate because of the design and the requirement to track the sun.

One of the drawbacks to solar energy is the need to provide some type of storage facility. Energy storage is generally provided by large water tanks or pebble beds. Storage is also possible in a material that changes phases as energy is absorbed or dissipated, such as wax

or certain types of salts, however, these may be quite expensive and must be replaced after certain periods of time. Another storage method, which may prove to be economical in the future, is the generation of hydrogen with excess photovoltaic electricity for later conversion to electricity utilizing a hydrogen fuel cell currently used by NASA.

The third portion of a solar heating and cooling system is the auxiliary heat/cooling system. Because the current expense of designing and installing a solar system that provides all the requirements of a building is quite high, the auxiliary system is used for peak periods that would exceed the capabilities of the solar system.

Finally, there is the distribution system to provide the energy transfer to the space for utilization. Distribution systems may be a fan and duct type of system or perhaps a piping system that carries a liquid to the space for use in a radiator.

When a designer is considering the heat requirements for a building, solar energy options should be given consideration particularly for the provision of low grade energy. As the supply of fossil fuels dwindles the incorporation of solar designs will become more prominent and necessary.

Wind has been providing a power source for many years in the form of windmills. These windmills have provided the power for farmers to pump water and crush grain. In some areas of the country it may be possible to incorporate a wind conversion system into the building design. Wind units have numerous drawbacks, however, and such a venture should be well researched before inclusion in a design is considered. A wind system generally requires a considerable amount of maintenance. Because of the location, usually on a tower of some kind, maintenance may be a significant problem. If the machine is located near an airport, or may cause interference with radio propagation, there may be Federal regulations that apply. In addition, state and local regulations must be considered prior to the installation of such a system. Finally, and most importantly, there must be enough wind to provide the power.

The earth itself may be used to provide the heating and cooling requirements for a building. A typical system is shown in figure 6-7. Depending on the location the temperature of the earth at depths of about 30 feet remains within five degrees of the yearly average air temperature. In addition, lakes, streams, and ground water may also be effectively utilized to provide the heating and cooling requirements of smaller buildings.

The earth systems use coils of piping buried under the ground either vertically or horizontally (see figures 6-8 and 6-9). The depth and length of the piping will be determined by the local environment and energy requirements. Another form of cooling is provided by utilizing earth tubes (see figure 6-10). These tubes have been in use for centuries. They are placed about eight feet underground and are constructed of metal, plastic, or masonry from eight to twenty inches in diameter. While the older systems relied on natural ventilation, the modern systems may use a fan or be coupled to a heat exchanger of some kind. The primary drawback to these systems is the high initial cost, because of the cost of excavation, however, if they can be installed in conjunction with other work, they may be an economical alternative.

Water systems may provide a more cost effective method to transfer energy to a structure. Piping may be placed in lakes or streams, a fluid circulated inside and the energy transferred either using a heat exchange or a heat pump. Piping may also be placed into the local ground water system and the water used to provide the heating and cooling requirements (see figure 6-11). Ground water has an advantage over lakes and streams because it's temperature tends to be more stable. Ground water systems

may be either open or closed systems. An open system withdraws the water and returns it via percolation or through a sewer system. A closed system circulates a liquid through the pipes and uses a heat exchanger of some kind to extract the energy.

When utilizing the earth systems consideration must be given to environmental limitations and any regulations which pertain to the use of these systems.

The technology involved in the alternate systems changes as time progresses, however the basic principles remain the same. Designers must consider the use of these systems in construction to achieve the optimal utilization of energy possible.

Energy Source For The Earth

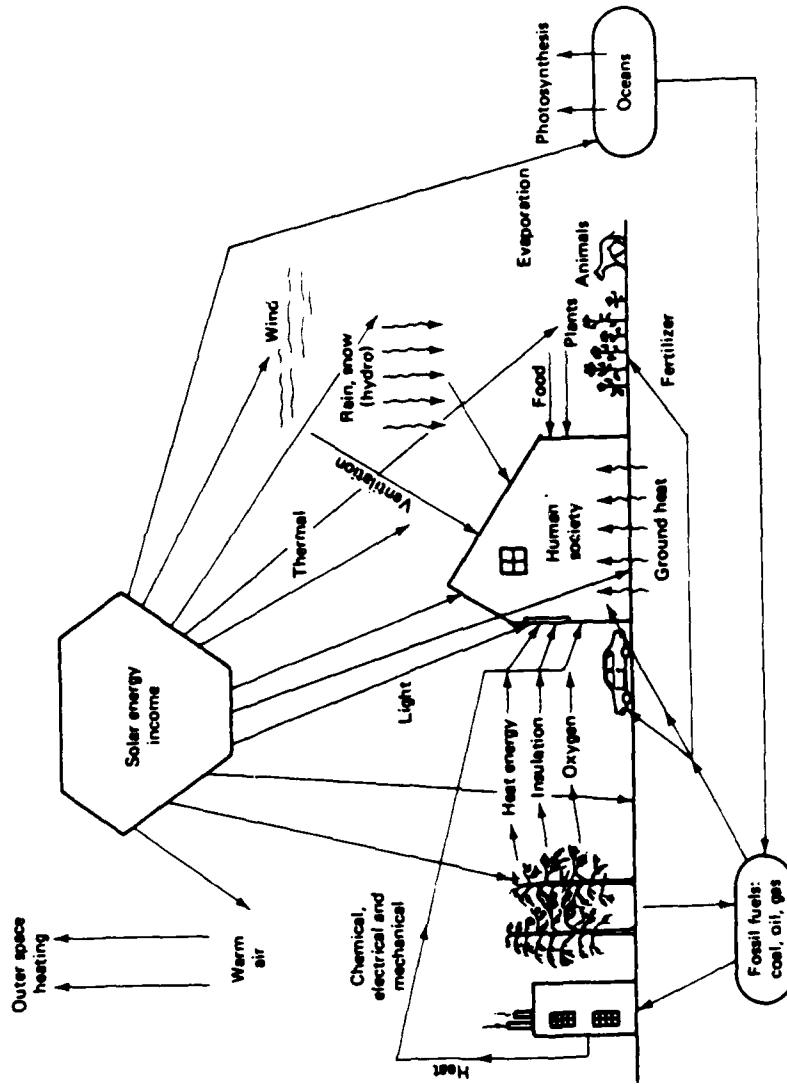

Solar energy: the lifeline.

FIGURE 6-1

(35)

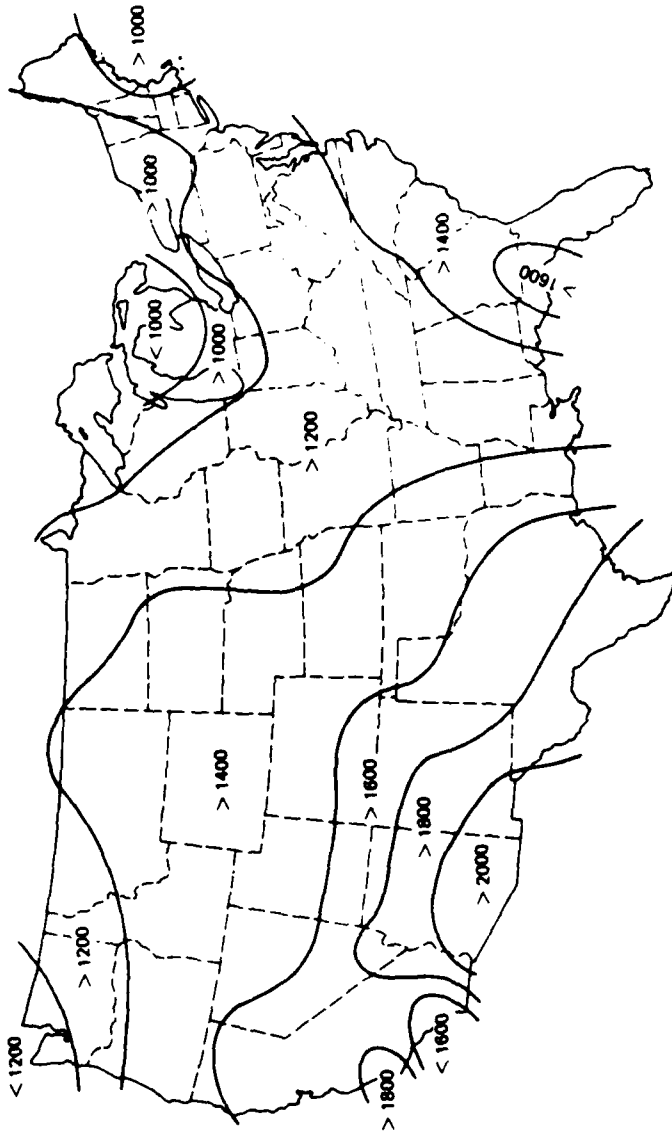

Average solar energy availability (Btu/ft² per day). (Source: U.S. Department of Energy.)

FIGURE 6-2
(36)

Passive Solar Design

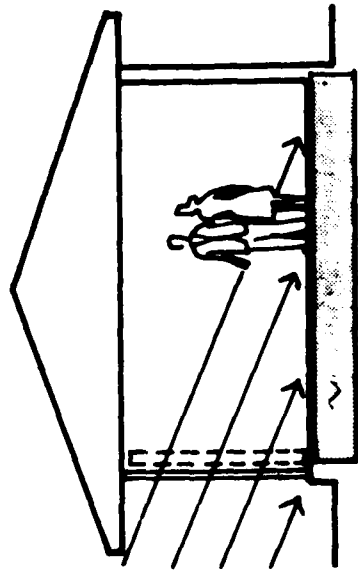

South facing window.

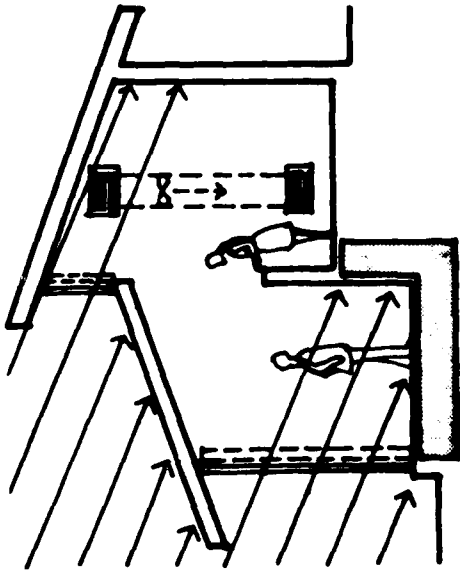

Roof Monitor as a Solar Collector. Duct and fan circulates trapped hot air back to floor level.

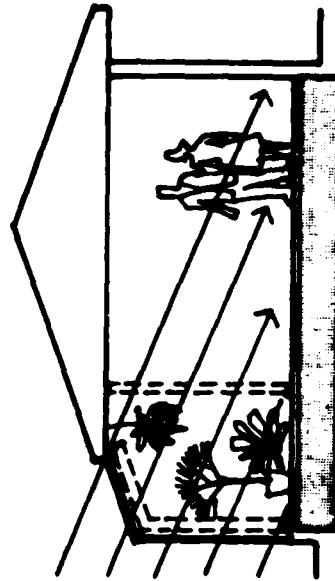

Greenhouse as a Solar Collector. Broken lines note movable insulation.

FIGURE 6-3
(37)

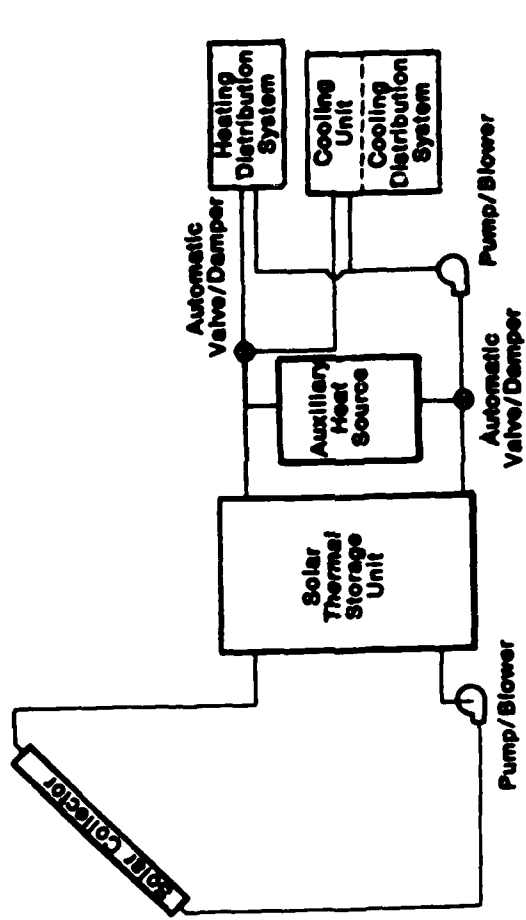

Schematic Representation of a Solar Heating and Cooling System.

FIGURE 6-4
(38)

Flat Plate Solar Collectors

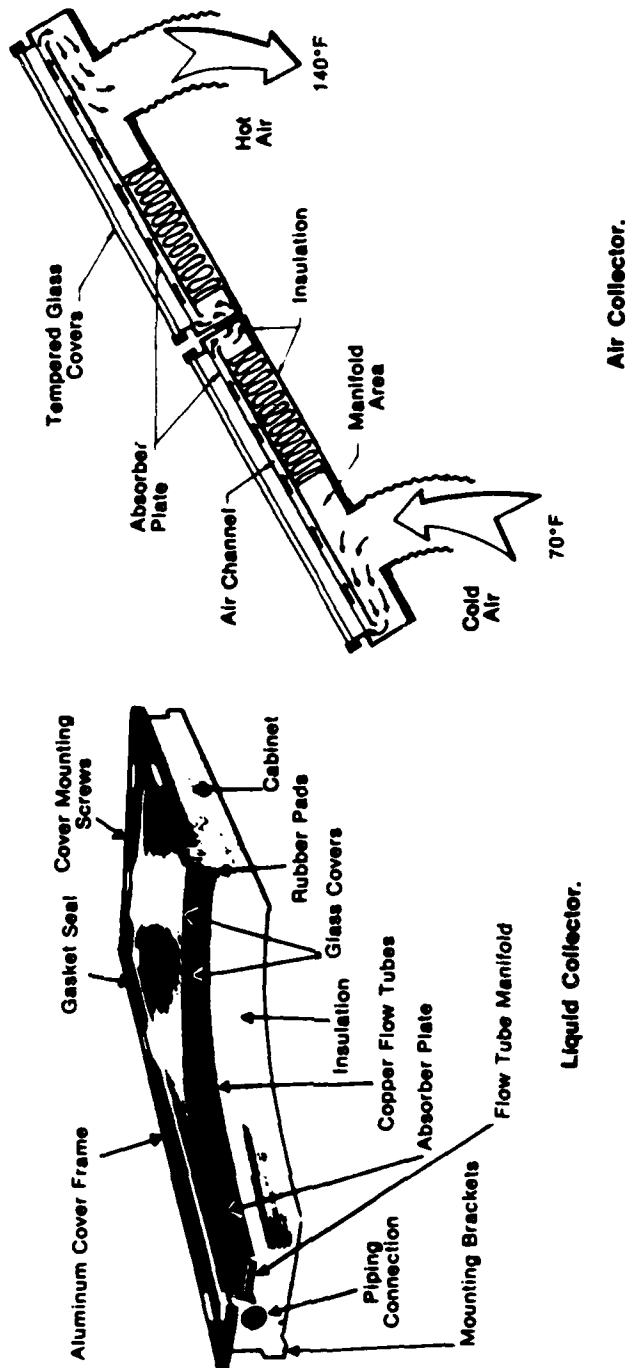
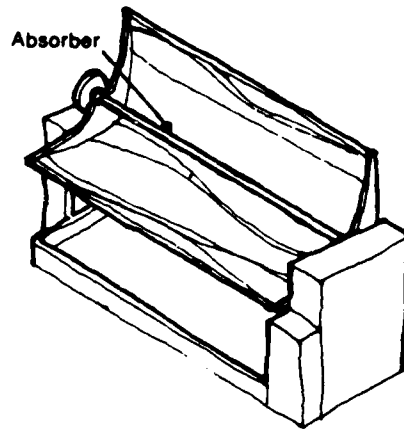
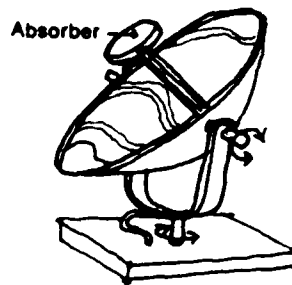

FIGURE 6-5
(39)

Concentrating Solar Collectors



Linear Concentrating Collector.



Circular Concentrating Collector.

FIGURE 6-6
(40)

Earth/Water Heating And Cooling System

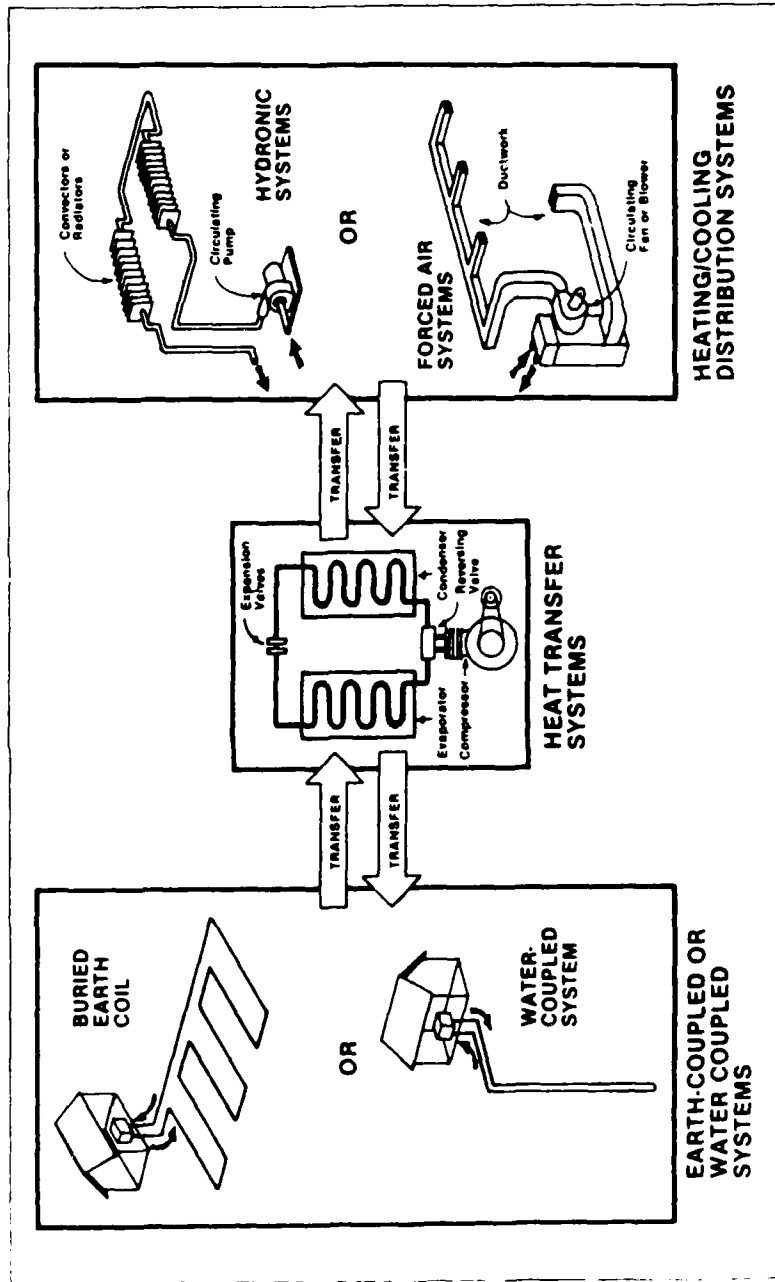

How earth-coupled and water-coupled systems can be used to heat and cool

FIGURE 6-7

(41)

Horizontal Earth Coil

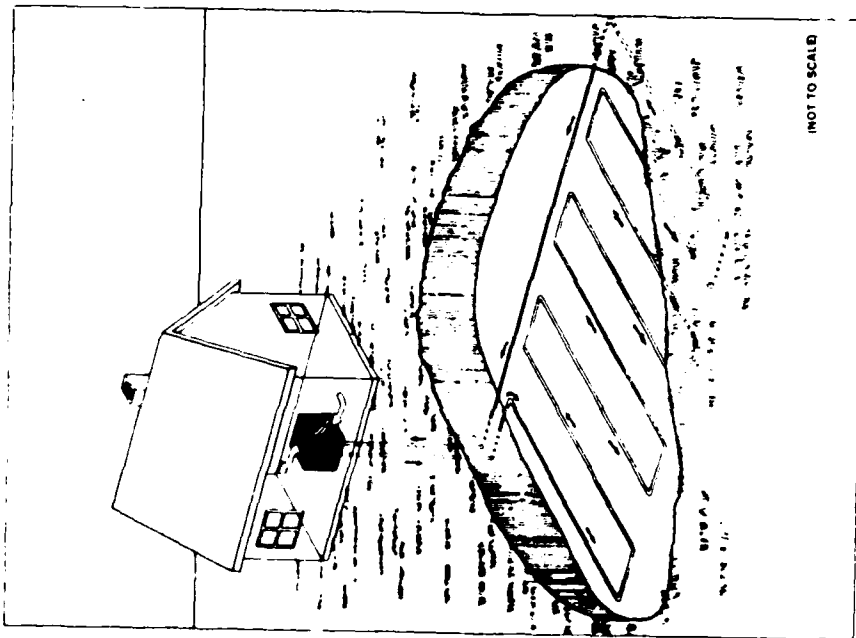

Horizontal earth coil.

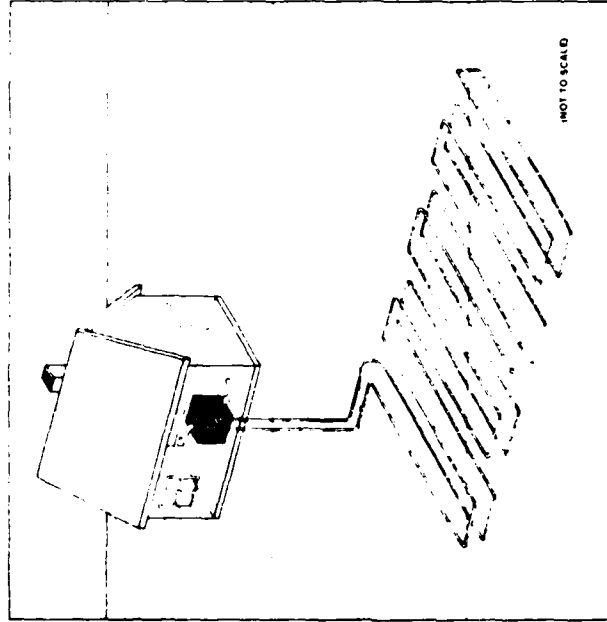

Multiple-layered horizontal earth coil.

FIGURE 6-8
(42)

Vertical Earth Coil

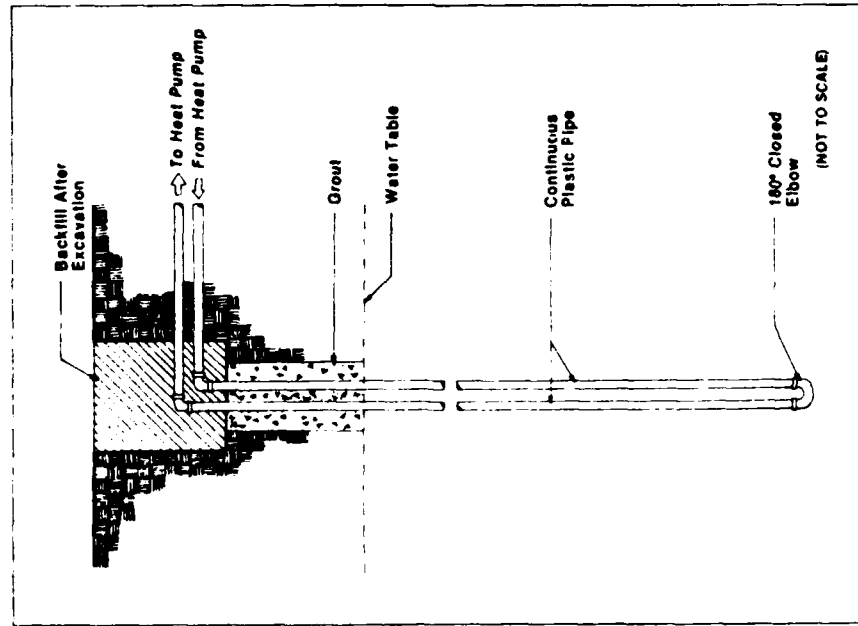

Closed-loop, vertical earth coil.

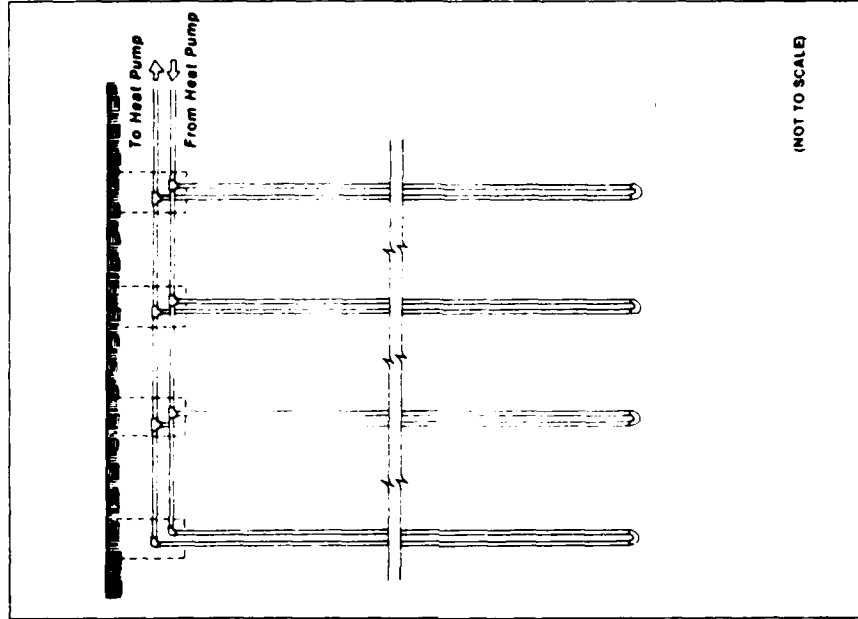

Parallel, closed-loop, vertical earth coil.

FIGURE 6-9
(43)

Cool Tube

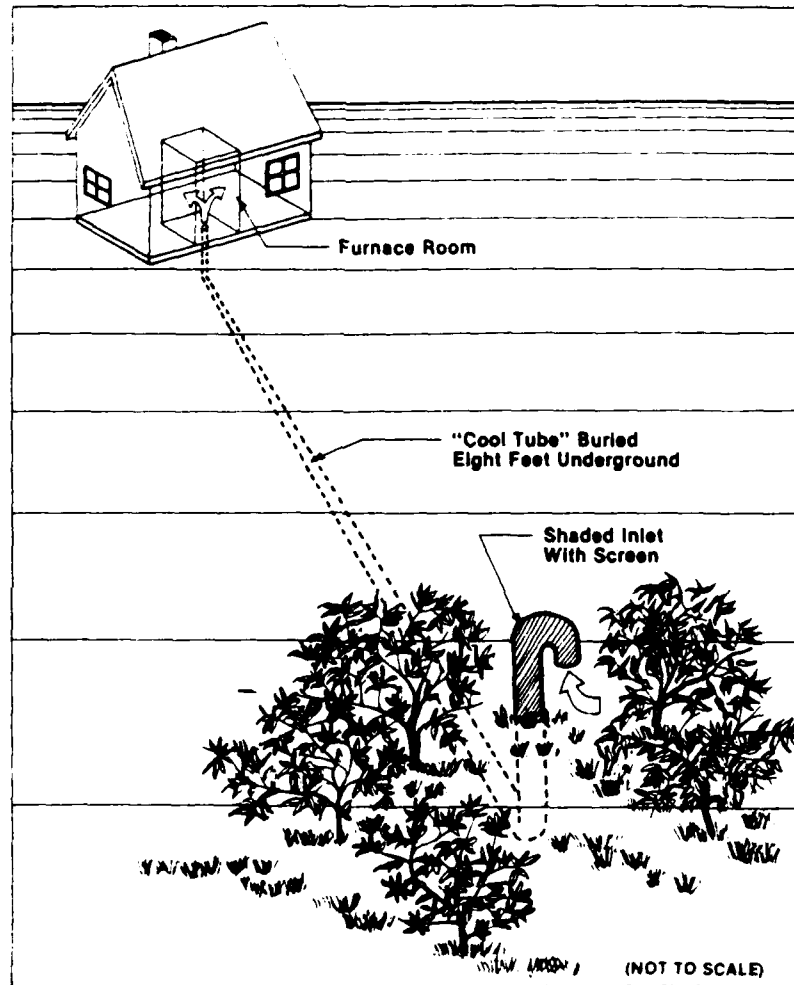
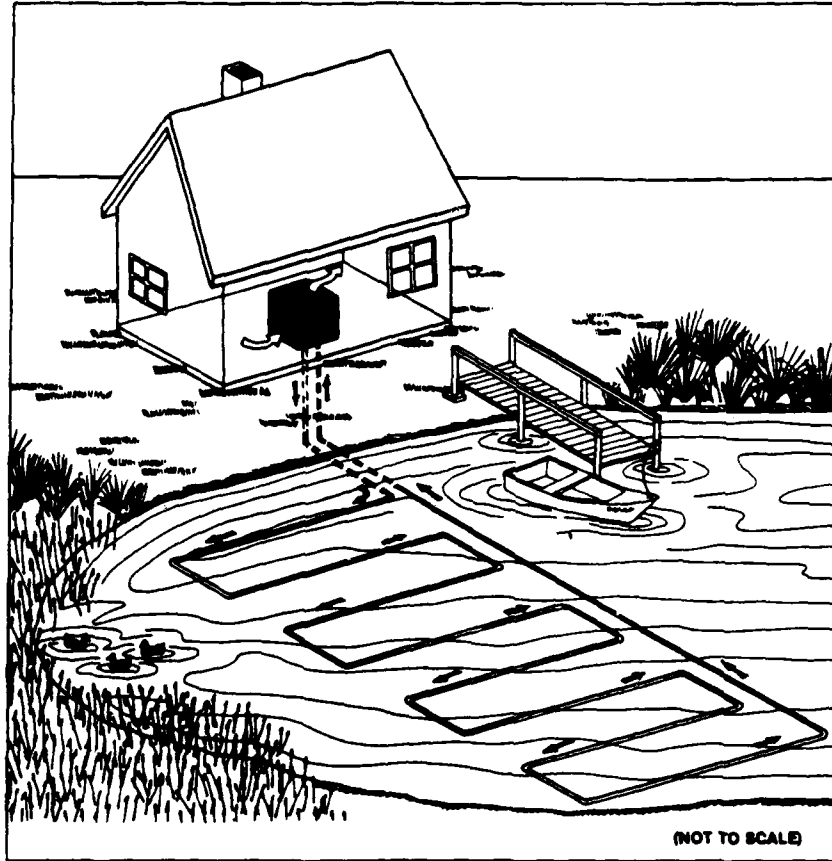

FIGURE 6-10

(44)

Water System



Closed-loop, water-coupled system.

FIGURE 6-11

(45)

CONCLUSIONS

The world has become more serene in it's energy conservation methods over the past few years. Overall world energy consumption in 1986 was 28% above that of 1973. As the memory of the oil embargo fades, and conformance to energy consumption standards is voluntary, the general public loses sight of the limitations in the earth's energy reserves. There are those that scoff at the claim that there is an energy problem and those that believe that an economical solution will be produced through technological advances. It is a fact that the earth's nonrenewable energy reserves are limited and it is possible that there will be an economical solution provided.

Our society is driven by the economics surrounding the current production costs of a particular service or supply. There is little thought as to how long a particular service or supply may be provided. As a result, unless people make a voluntary effort to curtail energy use, the future cost of energy may be exorbitant. If there is a shortage of inexpensive energy the living standards for many people may be in jeopardy.

An area that is not at all considered by the general public is what effect the conversion of all this energy will have on the planet. As the energy consumption per

capita rises, so will the amount of waste heat entering the earth's ecological system. Increasing the rate of heat being added to the system will result in an increasingly severe effect being realized in the overall climatic system.

Those personnel involved in the design, construction, and use of buildings, may have a positive impact on the energy problem. Energy efficient buildings, constructed to make use of the climate and alternate energy sources, will reduce the amount of energy used per capita. These buildings will prolong the life of the available energy reserves and reduce the amount of waste heat discharged into the ecosystem. It is incumbent upon owners and designers to utilize the most energy efficient and cost effective methods possible in the design and construction of buildings.

REFERENCES

1. Bailie, Richard C., Energy Conversion Engineering, Addison-Westley Publishing Company, Reading Massachusetts, 1975, p. 5.
2. Mitchell, John W., Energy Engineering, John Wiley and Sons Publishing Company, New York, New York, 1983, p. 306.
3. Mitchell, op. cit., p. 9.
4. O'Callaghan, P.W., Building for Energy Conservation, Pergamon Press, New York, New York, 1978, p. 5.
5. O'Callaghan, op. cit., p. 2.
6. O'Callaghan, op. cit., p. 3.
7. Mills, Russell, and Arun N. Toke, Energy, Economics, and the Environment, Prentice-Hall Publishing Company Inc., Englewood Cliffs, New Jersey, 1985, p. 42.
8. Mills, op. cit., p. 215.
9. O'Callaghan, op. cit., p. 5.
10. Mitchell, op. cit., p. 120.
11. O'Callaghan, op. cit., p. 51.
12. O'Callaghan, op. cit., p. 46.
13. Mitchell, op. cit., p. 122.
14. Mitchell, op. cit., p. 123.
15. Mitchell, op. cit., p. 89.
16. Mitchell, op. cit., p. 117.
17. Mitchell, op. cit., p. 35.
18. Mitchell, op. cit., p. 46.
19. Mitchell, op. cit., p. 36.
20. Mitchell, op. cit., p. 41.
21. Ibid.

REFERENCE(cont)

22. Mitchell, op. cit., p. 80.
23. Patrick, Dale R. and Stephen W. Fardo. Energy Management and Conservation, Prentice-Hall, Inc., Englewood Cliffs, New Jersey, 1982, p. 36.
24. O'Callaghan, op. cit., p. 257.
25. O'Callaghan, op. cit., p. 258.
26. O'Callaghan, op. cit., p. 259.
27. O'Callaghan, op. cit., p. 260.
28. O'Callaghan, op. cit., p. 267.
29. O'Callaghan, op. cit., p. 421.
30. Thompson, Grant P., Building To Save Energy: Legal and Regulatory Approaches, Ballinger Publishing Company, Cambridge, Massachusetts, 1980, p. 47.
31. Mitchell, op. cit., p. 26.
32. Stover, Dawn, Amazing Glazing, Popular Science, August 1988, pp 52-53.
33. Thompson, op cit., p. 162.
34. Thompson, op. cit., p. 161.
35. Mills, op. cit., p. 128.
36. Mills, op. cit., p. 129.
37. U.S. Department of Energy, Homemade Electricity, An Introduction to Small-Scale Wind, Hydro, and Photovoltaic Systems, U.S. Government Printing Office, 1984, p. 1-1.
38. U.S. Department of Energy, op. cit., p. 1-2.
39. U.S. Department of Energy, op. cit., p. 1-3.
40. U.S. Department of Energy, op. cit., p. 1-4.

REFERENCE(cont)

41. U.S. Department of Energy, Using the Earth To Heat and Cool Homes, U.S. Government Printing Office, 1983, p. 4.
42. U.S. Department of Energy, op. cit., p. 5, 13.
43. U.S. Department of Energy, op. cit., p. 5.
44. U.S. Department of Energy, op. cit., p. 9.
45. U.S. Department of Energy, op. cit., p. 6.

BIBLIOGRAPHY

1. Bailie, Richard C., Energy Conversion Engineering, Addison-Westley Publishing Company, Reading Massachusetts, 1978.
2. Economics of Solar Energy and Conservation Systems, volumes 1-3, edited by Frank Kreith and Ronald E. West, CRC Press Inc., Boca Raton, Florida, 1980.
3. Energy- Present and Future Options volume 1, edited by David Merrick and Richard Marshall, John Wiley and Sons Publishing Company, New York, New York, 1981.
4. Gilmore, V. Elaine, Smart House, Popular Science, August 1988, pp 42-46, 82-84.
5. Lees, Al, Are You Ready For a Plastic House?, Popular Science, August 1988, pp 47-47, 85.
6. Levy, Emanuel M., The Passive Solar Construction Handbook, Rodale Press, Emmaus, Pennsylvania, 1983.
7. Merklein, Helmut A. and W. Carey Hardy, Energy Economics, Gulf Publishing Company, Houston, Texas, 1977.
8. Mills, Russell, and Arun N. Toke, Energy, Economics, and the Environment, Prentice-Hall Publishing Company Inc., Englewood Cliffs, New Jersey, 1985.
9. Mitchell, John W., Energy Engineering, John Wiley and Sons Publishing Company, New York, New York, 1983.
10. O'Callaghan, P.W., Building for Energy Conservation, Pergamon Press, New York, New York, 1978.
11. Patrick, Dale R. and Stephen W. Fardo, Energy Management and Conservation, Prentice-Hall, Inc., Englewood Cliffs, New Jersey, 1982.
12. Stover, Dawn, Amazing Glazing, Popular Science, August 1988, pp 52-53.
13. Thompson, Grant P., Building To Save Energy: Legal and Regulatory Approaches, Ballinger Publishing Company, Cambridge, Massachusetts, 1980.
14. U.S. Energy Policy, edited by Walter J. Mead and Albert E. Utton, Ballinger Publishing Company, Cambridge, Massachusetts, 1979.

BIBLIOGRAPHY (cont)

15. Zillman, Donald N. and Laurence H. Lattman, Energy Law, Foundation Press Inc., 1983.
16. U.S. Department of Energy, Fundamentals of Solar Heating, U.S. Government printing Office, 1978.
17. U.S. Department of Energy, Homemade Electricity, An Introduction to Small-Scale Wind, Hydro, and Photovoltaic Systems, U.S. Government Printing Office, 1984.
18. U.S. Department of Energy, Using the Earth to Heat and Cool Homes, U.S. Government Printing Office, 1983.
19. U.S. Department of Housing and Urban Development, Regional Guidelines for Building Passive Energy Conserving Homes, U.S. Government Printing Office, 1980.