

DTIC FILE COPY

4

AD-A197 511

# Memory Tube Diffusion Studies

R. A. HERTZ, R. N. ABERNATHY, L. R. MARTIN, and R. B. COHEN  
Aerophysics Laboratory  
Laboratory Operations  
The Aerospace Corporation  
El Segundo, CA 90245

1 June 1988

Prepared for  
SPACE DIVISION  
AIR FORCE SYSTEMS COMMAND  
Los Angeles Air Force Base  
P.O. Box 92960, Worldway Postal Center  
Los Angeles, CA 90009-2960

DTIC  
ELECTE  
S JUL 27 1988 D  
E

APPROVED FOR PUBLIC RELEASE;  
DISTRIBUTION UNLIMITED

UNCLASSIFIED

SECURITY CLASSIFICATION OF THIS PAGE

## REPORT DOCUMENTATION PAGE

1a. REPORT SECURITY CLASSIFICATION Unclassified			1b. RESTRICTIVE MARKINGS		
2a. SECURITY CLASSIFICATION AUTHORITY			3. DISTRIBUTION / AVAILABILITY OF REPORT Approved for public release; distribution unlimited.		
2b. DECLASSIFICATION / DOWNGRADING SCHEDULE					
4. PERFORMING ORGANIZATION REPORT NUMBER(S) TR-0086A(2452-21)-1			5. MONITORING ORGANIZATION REPORT NUMBER(S) SD-TR-88-59		
6a. NAME OF PERFORMING ORGANIZATION The Aerospace Corporation Laboratory Operations		6b. OFFICE SYMBOL (If applicable)	7a. NAME OF MONITORING ORGANIZATION Space Division		
6c. ADDRESS (City, State, and ZIP Code) El Segundo, CA 90245			7b. ADDRESS (City, State, and ZIP Code) Los Angeles Air Force Base Los Angeles, CA 90009-2960		
8a. NAME OF FUNDING / SPONSORING ORGANIZATION		8b. OFFICE SYMBOL (If applicable)	9. PROCUREMENT INSTRUMENT IDENTIFICATION NUMBER FO4701-85-C-0086-P00016		
8c. ADDRESS (City, State, and ZIP Code)			10. SOURCE OF FUNDING NUMBERS		
		PROGRAM ELEMENT NO.	PROJECT NO.	TASK NO.	WORK UNIT ACCESSION NO.
11. TITLE (Include Security Classification) Memory Tube Diffusion Studies					
12. PERSONAL AUTHOR(S) Hertz, Robert A., Abernathy, Robert N., Martin, Laurence R., and Cohen, Ronald B.					
13a. TYPE OF REPORT		13b. TIME COVERED FROM _____ TO _____	14. DATE OF REPORT (Year, Month, Day) 1 June 1988		15. PAGE COUNT 32
16. SUPPLEMENTARY NOTATION					
17. COSATI CODES			18. SUBJECT TERMS (Continue on reverse if necessary and identify by block number)		
FIELD	GROUP	SUB-GROUP	Hydrogen Disposal System		
			Hydrogen Sampling System		
19. ABSTRACT (Continue on reverse if necessary and identify by block number)					
<p>Memory tubes were devised to sample the gas composition in the Space Shuttle Main Engine (SSME) duct at many locations (33-100) using only a few mass spectrometers (1-3). The feasibility of this technique was evaluated by examining the capability of long tubes to transport and store time-varying gas composition data with sufficient time resolution to rule out the existence of hazardous hydrogen-air mixtures in the duct. The procedure was (1) to examine the theoretical and experimental behavior of gas mixtures during flow and storage in long tubes, (2) to optimize the flow conditions and tube size for maximum resolution for up to 1 hr storage, and (3) to characterize the time resolution of the memory tube so that computer deconvolution could be used to maximize information recovery.</p> <p>In this report, we present the results of the memory tube experiments conducted in the Aerophysics Laboratory. The diffusion behavior of oxygen and helium was in rough agreement with G.I. Taylor's equations for both laminar and turbulent flow in 1/4 and 3/8 in. OD tubes (0.035 in. wall thickness). Both 300 and 75 ft memory tubes were studied. Time resolution,</p>					
20. DISTRIBUTION / AVAILABILITY OF ABSTRACT <input type="checkbox"/> UNCLASSIFIED/UNLIMITED <input checked="" type="checkbox"/> SAME AS RPT <input type="checkbox"/> DTIC USERS			21. ABSTRACT SECURITY CLASSIFICATION Unclassified		
22a. NAME OF RESPONSIBLE INDIVIDUAL			22b. TELEPHONE (Include Area Code)		22c. OFFICE SYMBOL

DD FORM 1473, 84 MAR

83 APR edition may be used until exhausted  
All other editions are obsolete.SECURITY CLASSIFICATION OF THIS PAGE  
UNCLASSIFIED

SECRET  
UNCLASSIFIED

SECURITY CLASSIFICATION OF THIS PAGE

as measured by the FWHM broadening of very short gas pulses, was 0.380 and 0.350 sec, respectively, for oxygen in 1/4 and 3/8 in. OD memory tubes, and 0.300 and 0.270 sec for helium in 300 ft tubes. Time resolution for the 75 ft, 3/8 in. memory tube was 0.125 sec for oxygen. The time resolution for 75 and 300 ft memory tubes was measured at an average flow speed of 30 fps, with a Reynolds number of 2200 for the 1/4 in. tubes and 4200 for the 3/8 in. tubes. Time resolution was also characterized by a frequency response, which was measured by comparing the Fourier transform of output pulses to the Fourier transform of input pulses. The results indicate that information is present up to 4 or 5 Hz in 300 ft tubes and 9 to 10 Hz in 75 ft tubes. Deconvolution, or frequency compensation, should enable reconstruction of input pulses of approximately 0.1 sec FWHM in the 75 ft tubes and 0.2 sec FWHM in the 300 ft tubes.

UNCLASSIFIED

SECURITY CLASSIFICATION OF THIS PAGE

PREFACE

We would like to thank J. Pollard of the Aerophysics Laboratory, whose proof of concept experiments provided inspiration for the work presented here. We especially want to thank J. Powelson of Martin Marietta Aerospace, Denver, for essential contributions to the theory of the memory tubes. In addition, we appreciate the contributions of D. Moody, A. Woodin, D. Pridmore-Brown, H. Yura, C. Christopher, and J. Hiatt, all from The Aerospace Corporation.

Accession For	
NTIS GRA&I	<input checked="" type="checkbox"/>
DTIC TAB	<input type="checkbox"/>
Unannounced	<input type="checkbox"/>
Justification	
By _____	
Distribution/	
Availability Codes	
Special and/or	
Dist	Special
A-1	



CONTENTS

PREFACE . . . . .	1
I. INTRODUCTION . . . . .	7
II. EXPERIMENTAL . . . . .	11
III. RESULTS AND DISCUSSION . . . . .	17
REFERENCES . . . . .	35

## FIGURES

1. Memory Tube Concept Illustrating the Remote Sampling Approach. . . . .	9
2. Aerospace Memory Tube Testbed . . . . .	12
3. Experimental Results for Fixed Sample Loop Lengths (oxygen) as a Function of Average Flow Velocity for the 3/8 in., 300 ft Memory Tube . . . . .	18
4. Experimental Results for Varying Sample Loop Lengths (oxygen) at $V_{avg} = 30$ ft/sec ( $P_o = 580$ Torr) for the 3/8 in., 300 ft Memory Tube . . . . .	19
5. Typical Oxygen Input Peak (0.040 sec FWHM) for the 3/8 in., 300 ft Memory Tube Generated from the Solenoid Source . . . . .	21
6. Typical Unstored Oxygen Output Peak (0.300 sec FWHM) for the 3/8 in., 300 ft Memory Tube . . . . .	22
7. Fourier Transform Analysis of the Input and Output Peaks Shown in Figs. 5 and 6. . . . .	23
8. Experimental Transfer Function for the 3/8 in., 300 ft Memory Tube Showing the 4 Hz Frequency Cutoff . . . . .	25
9. Experimental Transfer Function for the 3/8 in., 75 ft Memory Tube Showing the 10 Hz Frequency Cutoff . . . . .	26
10. Experimental Transfer Function for the 3/8 in., 300 ft Memory Tube Using Helium with No Storage . . . . .	27
11. Experimental Transfer Function for the 3/8 in., 300 ft Memory Tube Using Helium Stored for 1 hr Showing Only a Minor Effect on Frequency Response . . . . .	28
12. Theoretical Fit to an Experimental Transfer Function Using Eq. (6) ( $K = 0.99$ ) for an Unstored Oxygen Sample . . . . .	30

FIGURES (continued)

13. Theoretical Fit to an Experimental Transfer Function Using Eq. (6) ( $K = 1.70$ ) for an Oxygen Sample Stored for 1 hr. . . . .	31
14. Reconstructed Oxygen Sample for the 3/8 in., 75 ft Memory Tube Using 10 Basis Functions in the Fourier Series. . . . .	33

## I. INTRODUCTION

In the late 1970s, the Air Force renovated Space Launch Complex #6 (SLC-6) at Vandenberg Air Force Base (VAFB) for Shuttle launches. SLC-6, which was originally designed for the Manned Orbiting Laboratory (MOL), has long, large enclosed ducts for the solid rocket booster launch exhaust and for the hydrogen, oxygen burning main engine exhaust. During the main engine shutdown after a test or in a launch abort sequence, up to 200 lb of hydrogen is injected into the main engine duct in less than 10 sec, producing potentially explosive hydrogen-air mixtures whose ignition would be an extreme hazard to the Shuttle and the launch site.

Upon identification of this hazard, the focus of the program office effort was to identify an approach that would guarantee the safety of the Shuttle and launch site during a shutdown or abort sequence. Because of the complexity of the problem and the small margin of error (the lower explosion limit for hydrogen in air is only 5%), it was concluded that subscale and full scale validation tests were required to demonstrate launch readiness.

To validate the safety of a proposed solution to the problem, duct gas composition would have to be measured at many locations in the duct with good time resolution. The goal of the "memory tube" technique was to sustain concentration measurements of hydrogen, oxygen, nitrogen, carbon dioxide, helium, and argon in a hot, steam, and aerosol laden environment at 100 locations with 0.10 sec resolution at reasonable cost. These data would provide a basis for the engineering development and the reduced and full scale validation tests.

Mass spectrometer and optical detection systems can reliably and quantitatively measure the concentrations of 6 to 10 gases from 1 to 0.001 atm pressure at 10 Hz (0.10 sec

resolution) for each gas. We could not install 100 such systems in the main engine duct to support full scale tests. It is possible, however, to combine a mass spectrometer system with a remote sampling approach to accomplish the task. This is the origin of the "memory tube" approach.

The goals of the memory tube concept were to enable remote gas sampling at many locations, storage of the gas samples (up to 60 min) until their contents could be analyzed, and deconvolution of the data so that the time varying duct gas concentrations could be recovered to a resolution of 10 Hz (0.1 sec). Deconvolution of the data enables partial recovery of the information that is lost by gas diffusion during the period that the tube is filled, while it is stored, and while it is transferred to the mass spectrometer system for analysis.

Figure 1 is a schematic of the memory tube concept. The argon marker pulse provides an internal standard for flow and storage broadening and a time marker for each tube.

The experiments examined the scope and systematics of the memory tube concept. The memory tube diffusion behavior of oxygen and helium was inspected under laminar ( $Re < 1500$ ) and turbulent flow ( $Re > 2000$ ). The results of this inspection were then compared with flow theory, with subsequent determination of the limiting resolution of memory tubes for conditions consistent with sampling the SLC-6 duct.

The theory of diffusion in flowing systems is based on a series of classical papers published by G.I Taylor in the early 1950s. In these papers, empirical equations are presented for laminar and turbulent flow. Taylor defines a virtual diffusion coefficient  $K$  as:

$$K = r^2 U^2 / 48D \quad \text{laminar flow} \quad (1)$$

$$K = 7.14 r U f^{1/2} \quad \text{turbulent flow} \quad (2)$$

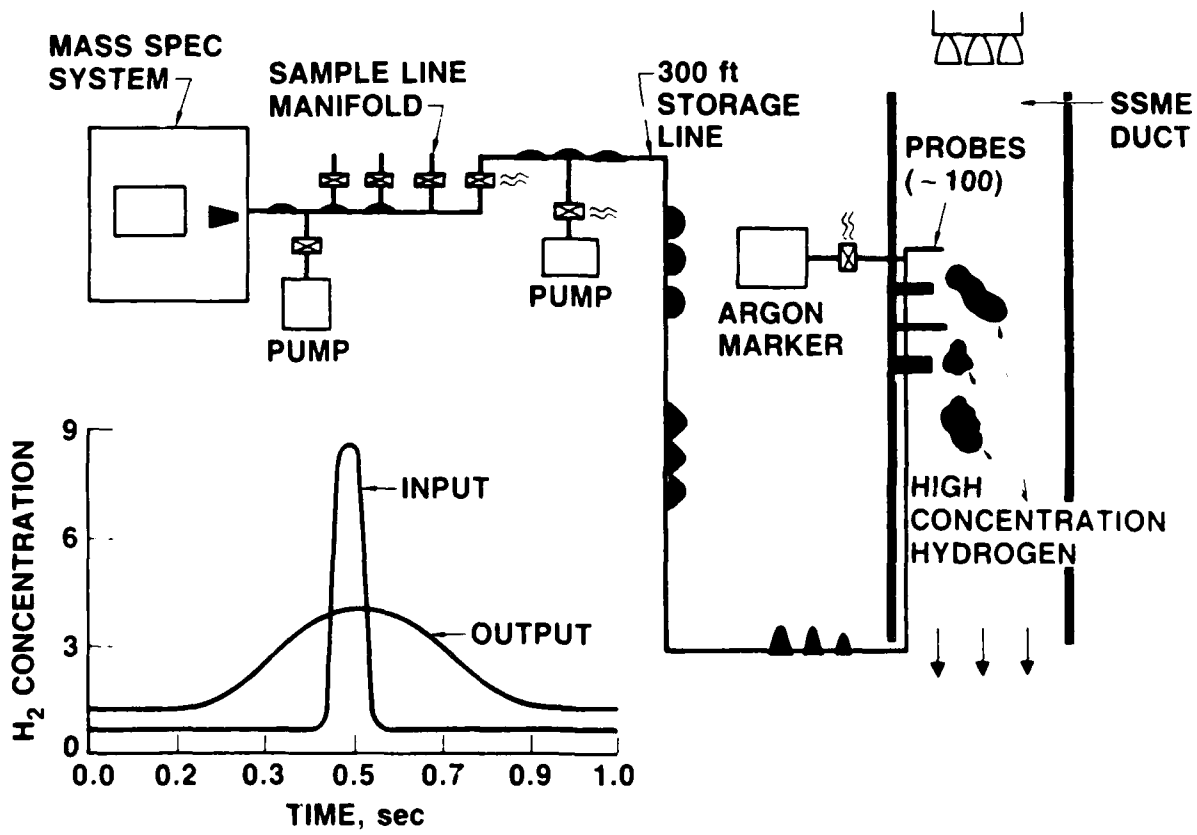

Fig. 1. Memory Tube Concept Illustrating the Remote Sampling Approach

where  $r$  is the radius of the pipe,  $U$  is the mean fluid velocity,  $D$  is the molecular diffusion coefficient, and  $f$  is a friction factor (Refs. 1 and 2). The inverse dependence of virtual diffusion on molecular diffusion for laminar flow is a curious, although justifiable, result. The parabolic velocity profile in laminar flow would cause considerable smearing of the sample if not for radial diffusion acting to re-establish plug flow. Therefore, resolution in laminar flow is higher for lighter species with larger molecular diffusion coefficients. Interestingly, Taylor's equation for turbulent flow suggests that the resolution is insensitive to the steady state diffusion characteristics of the gas. The broadening due to storage has the opposite dependence to the laminar flow broadening - it becomes worse for lighter species. These factors were compared quantitatively in a previous memorandum [ATM-86A(6452-21)-16], which estimated that the optimum size for memory tubes was approximately 300 ft long with a 1/4 in. ID.

The results of the work presented here show that the ultimate resolution for a 300 ft tube is 4-5 Hz. To achieve 9-10 Hz resolution, a 75 ft tube that can store a 2.5 sec sample must be used. Four such tubes, operating sequentially, are needed to maintain 9-10 Hz resolution for a 10 sec sample.

## II. EXPERIMENTAL

The experimental apparatus, shown in Fig. 2, consists of a memory tube, gas manifold, a sampling loop, a vacuum pump, and a series of valves used to direct the gas flow and adjust the pressure drop across the memory tube. A Perkin Elmer MGA-1200 mass spectrometer is connected to the input and output of the memory tube through two, 10 ft long capillaries. The MGA-1200 is a magnetic sector mass analyzer with fixed Faraday cups that can monitor the concentration of eight gases simultaneously between 0.1 and 100%. The MGA-1200 sends an analog voltage (0-10 V) to a storage oscilloscope (Norland Prowler oscilloscope) and to an A/D converter connected to a Micro Vax II computer. The A/D converter and the storage oscilloscope sample the MGA-1200 output every 20 and 1 msec, respectively.

Unoxidized hydrogen is injected into the exhaust duct during a main engine shutdown sequence that lasts about 10 sec. The memory tube system samples each of 100 locations during this 10 sec period. Each tube must have a fill velocity that can retain the required time resolution for up to 60 min storage prior to the mass spectral analysis of the contents of the last memory tube. Because the temporal resolution decreases as the fast fill period increases, we examined 300 and 75 ft memory tubes representing fill times of 10 and 2.5 sec, respectively. The memory tubes were constructed of 1/4 and 3/8 in. OD stainless steel with a 0.035 in. wall thickness. The tubes were assembled from straight lengths that were connected by orbital welds. The tubes were then bent into 4 ft diameter coils by turning the welded lengths onto a circular jig; the entrance and exit lengths protruded approximately 7 ft from the body of the coil.

To determine the time resolution of the tubes, three types of experiments were performed: (1) introduction of fixed physical length pulses with varying flow speeds,

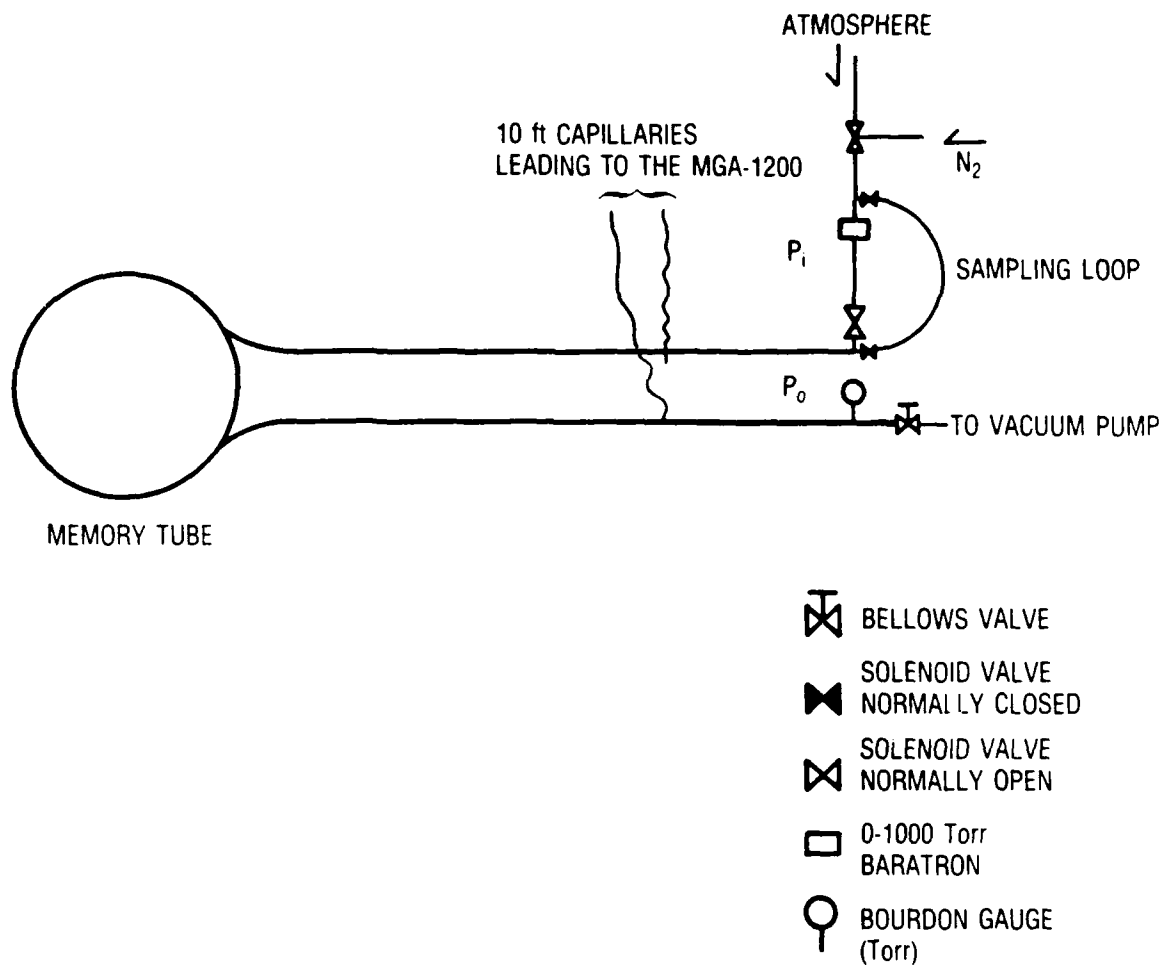

Fig. 2. Aerospace Memory Tube Testbed. Different pulse lengths can be easily substituted into the sampling loop.

(2) introduction of variable physical length pulses with fixed flow speeds, and (3) introduction of very short pulses with Fourier analysis of the pulse shapes before and after passage of the pulses through the tube. The purpose of the first type of experiment was to determine the qualitative effects of velocity and turbulence on pulse broadening. The purpose of the second type of experiment was to find the relationship of output pulse length to input pulse length to determine the minimum output length. The purpose of the third type of experiment was to measure the frequency response of the tubes quantitatively so that deconvolution of the peaks could be performed.

The first set of experiments used the smallest sample loop length (2.33 ft for 1/4 in. and 1.50 ft for 3/8 in.) that would physically fit into the apparatus. The velocity was set by adjusting the pressure drop through a valve leading to the pump. The mass spectrometer requires a constant flow into its ionization chamber; therefore, the pressure at the memory tube output was limited to approximately 200 Torr. We were interested in covering a wide range of Reynolds numbers (100-5000) but were also cautious about keeping pressure drops to less than 1/2 atm, since it was thought that too great a pressure drop might distort the data during starting and stopping transients. For 3/8 in. memory tubes, it wasn't difficult to minimize pressure drops; however, 1/4 in. memory tubes would enter turbulent flow only at pressure drops close to 1/2 atm.

The first set of experiments relating pulse broadening to Reynolds number was started by filling the sampling loop with air at 760 Torr. The pressure at the input was then adjusted with nitrogen to 760 Torr. After the isolation valve was opened, the air sample was pushed out of the sample loop past the input sampling point, where the oxygen response (input pulse) was recorded by the mass spectrometer. After a fixed transit time,

the sample reached the output sampling point, where the oxygen distribution (output pulse) was analyzed.

In the second set of experiments, the length in the sample loop was varied, and the average velocity was set to give a 10 sec transit time in the 300 ft memory tube ( $V_{avg} = 30$  ft/sec). The output pressure for 1/4 and 3/8 in. memory tubes was 450 and 580 Torr, respectively. The experiment involved the following sequence: filling the sample loop with air at 760 Torr, adjusting the pressure at the input to 760 Torr with nitrogen, and opening the valve isolating the sample loop from the memory tube. The oxygen signal was then recorded at the memory tube input and output as the air sample traveled through the memory tube.

The third set of experiments was similar to the second set, except the sample was not contained in a sample loop. Instead, the gas source emanated from a 1/8 in. stainless steel tube attached to a solenoid arm moving perpendicular to the memory tube inlet. The average velocity in the memory tube was fixed at 30 ft/sec, and helium and oxygen were used as sample gases. This arrangement was used to give very short input pulses. As in the other experiments, the mass spectrum of the sample was collected as it passed the memory tube input and output sampling points.

Gas samples generated by both the sample loop and solenoid source were stored for up to an hour after allowing the samples to flow for a 5 sec fill period. The pump was stopped during storage, and the input and output pressure was 760 Torr during the storage interval. After storage, pumping was resumed, and the percent concentration of the sample was recorded at the memory tube outlet.

To verify that the frequency response of the system was adequate, the mass spectrometer data were supplemented by UV absorption data. Oxygen has a large one photon absorption cross section at 170 nm, which permits direct, high temporal

resolution of the oxygen distribution in the flowing tube. The 1/4 in. stainless steel pipe separating the sample loop from the memory tube inlet was replaced with 4 mm ID (1 mm wall) Suprasil cultured quartz tube. The output of a Hamamatsu deuterium lamp (model No. L1626) was directed by a slit through the Suprasil tube into a second slit leading to a Hamamatsu solar blind photomultiplier tube (model No. R166UH). Stray room light was attenuated by placing an Acton Research interference filter (172 nm, 16 nm FWHM) in front of the photomultiplier tube. Linear Beer's law behavior was achieved by keeping optical densities below 0.05.

### III. RESULTS AND DISCUSSION

Typical results for the Reynolds number experiments for a 3/8 in. memory tube are shown in Fig. 3. The resolution, T, for Gaussian peak shapes is calculated from

$$T = \{ FWHM_o^2 - FWHM_i^2 \}^{1/2} \quad (3)$$

where FWH<sub>o</sub> and FWH<sub>i</sub> are the full time width at half peak height of the output and input, respectively. Reynolds number is calculated from

$$Re = \rho d U / \gamma \quad (4)$$

where  $\rho$  is the average density,  $D$  is the tube diameter,  $U$  is the average fluid velocity, and  $\gamma$  is the viscosity of oxygen or helium in nitrogen.

The Reynolds number plot indicates that the resolution increases as the velocity is increased, which is a direct consequence of the decreasing transit time. When converted into effective diffusion coefficients, these data are roughly consistent with the Taylor theory of broadening. The onset of turbulence produces a decrease in broadening; a further decrease at high Reynolds numbers is minimal.

In the second set of experiments, we fixed the average velocity to give a 10 sec transit time and substituted different lengths into the sample loop. The results of these experiments are shown in Fig.4 for a 3/8 in. tube. This figure is a plot of width-out versus width-in for a series of different sample lengths. The FWH<sub>o</sub> approaches a definite asymptote at shorter sample lengths, suggesting that an infinitely narrow input would also assume a position on this asymptote. Therefore, the

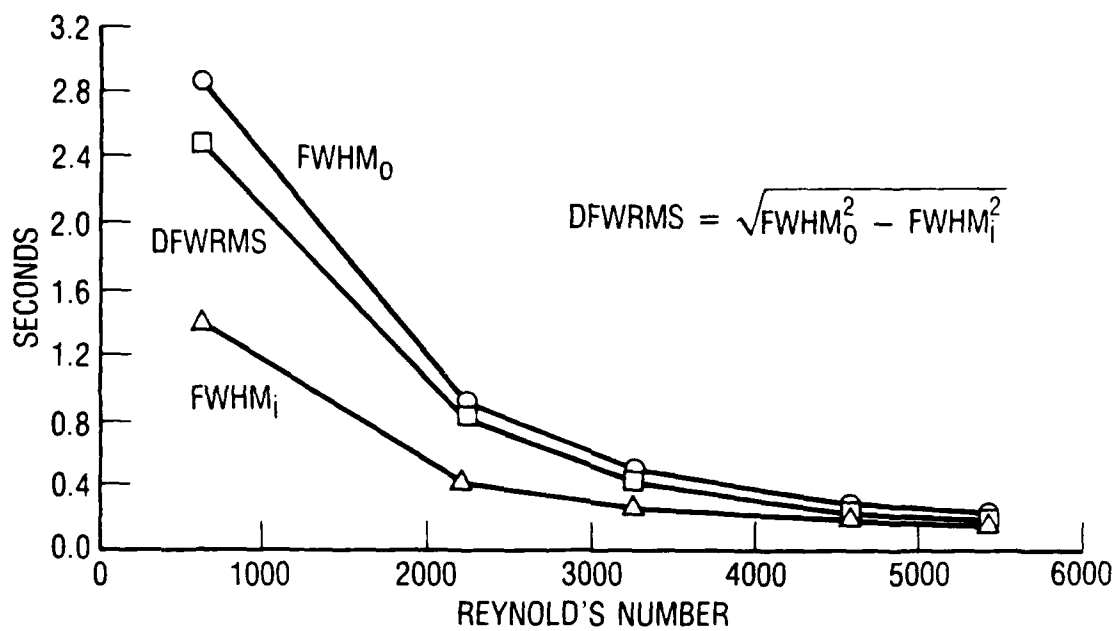

Fig. 3. Experimental Results for Fixed Sample Loop Lengths (oxygen) as a Function of Average Flow Velocity for the 3/8 in., 300 ft Memory Tube

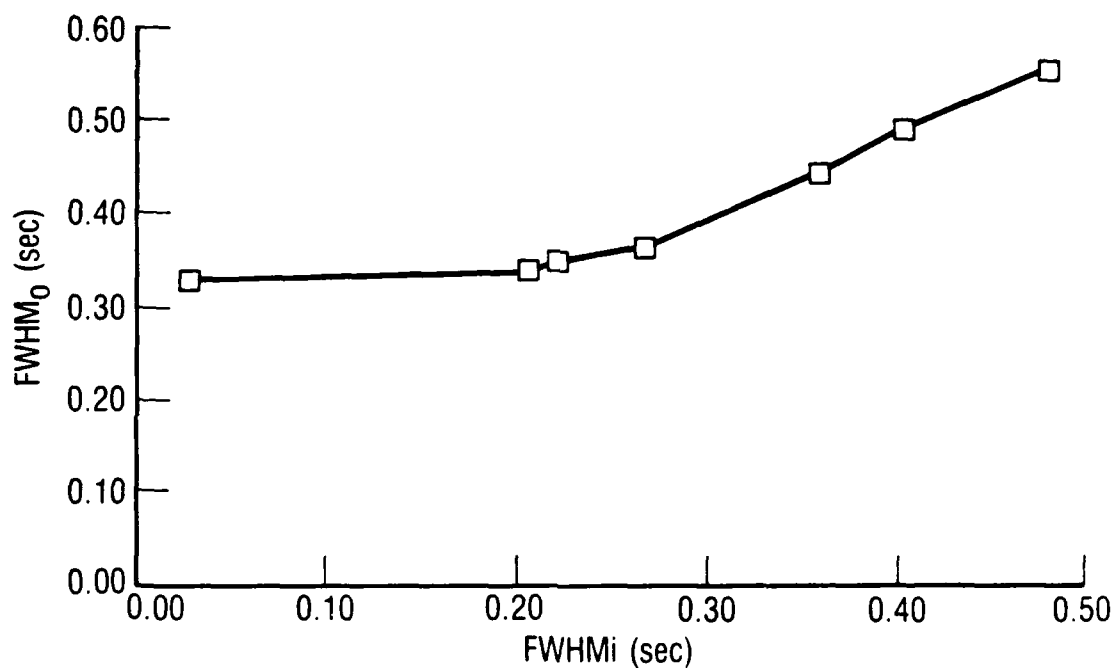

Fig. 4. Exerimental Results for Varying Sample Loop Lengths (oxygen) at  $V_{avg} = 30$  ft/sec ( $P_o = 580$  Torr) for the 3/8 in., 300 ft Memory Tube. The asymptote shows the limiting resolution to be 0.330 sec.

limiting pulse width is clearly defined at the asymptote for a given tube under a given set of conditions. To decorvolute, we must have exact knowledge of the frequency response of the tubes. To obtain this knowledge, the next series of experiments were performed.

For the third set of experiments, the frequency response determinations were not to be influenced by limitations in the mass spectrometer and readout equipment. To measure the time resolution of this equipment, we had to generate and detect very short pulses of gas. For this purpose, we developed a solenoid operated oxygen pulse generator and the UV absorption detector described earlier. We operated the pulse generator by swinging an oxygen jet past the inlet tube. Pulses as narrow as 30 msec were generated. This setup made it possible to verify that the responses of the system components, including the mass spectrometer, were fast enough that they did not interfere with the memory tube measurements. Having verified this, the following experimental measurements were done with the mass spectrometer.

The goal in the third series of experiments was to measure carefully the shape of a short input pulse and its resulting output pulse and to take the Fourier transforms of the pulses. This approach was suggested by Judy Powelson of Martin Marietta Corporation in Denver. Because a Fourier transform gives the frequency content of a pulse, we could use the transforms to measure the frequency response of the memory tubes. The narrow input pulse has a broad range of frequencies; the wider output pulse has fewer frequency components. The ratio of the output transform to the input transform, i.e., the transfer function, is the frequency response curve of the memory tube.

Typical input and output peak shapes for a 3/8 in. memory tube are shown in Figs. 5 and 6, respectively, and the corresponding Fourier transforms are shown in Fig. 7. The

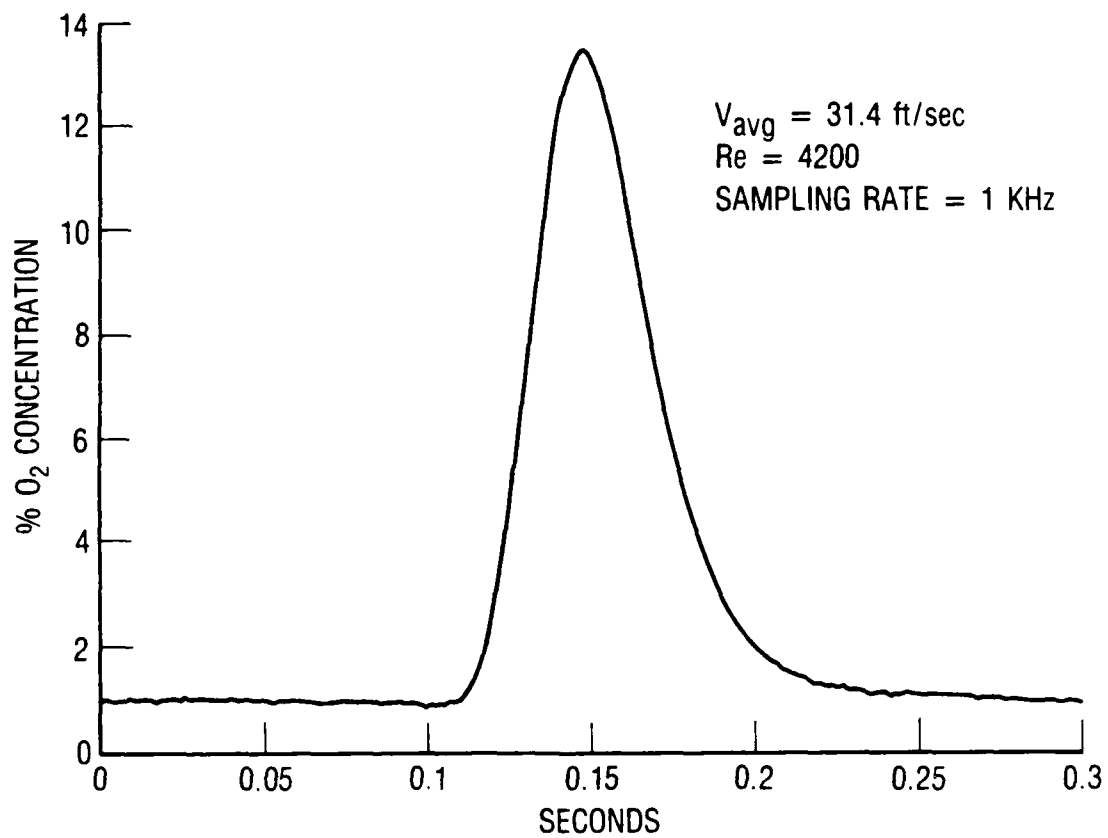

Fig. 5. Typical Oxygen Input Peak (0.040 sec FWHM) for the 3/8 in., 300 ft Memory Tube Generated from the Solenoid Source

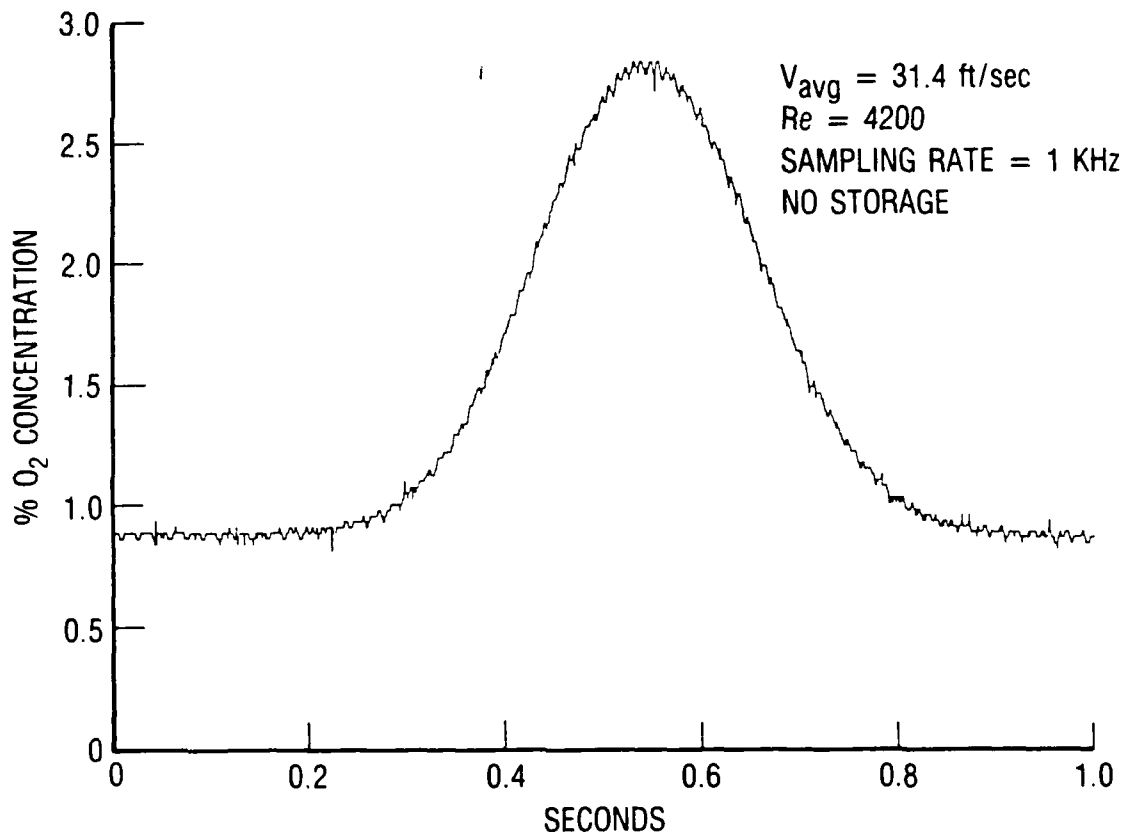

Fig. 6. Typical Unstored Oxygen Output Peak (0.300 sec FWHM) for the 3/8 in., 300 ft Memory Tube. Note the width of the peak agrees with the results shown in Fig. 4.

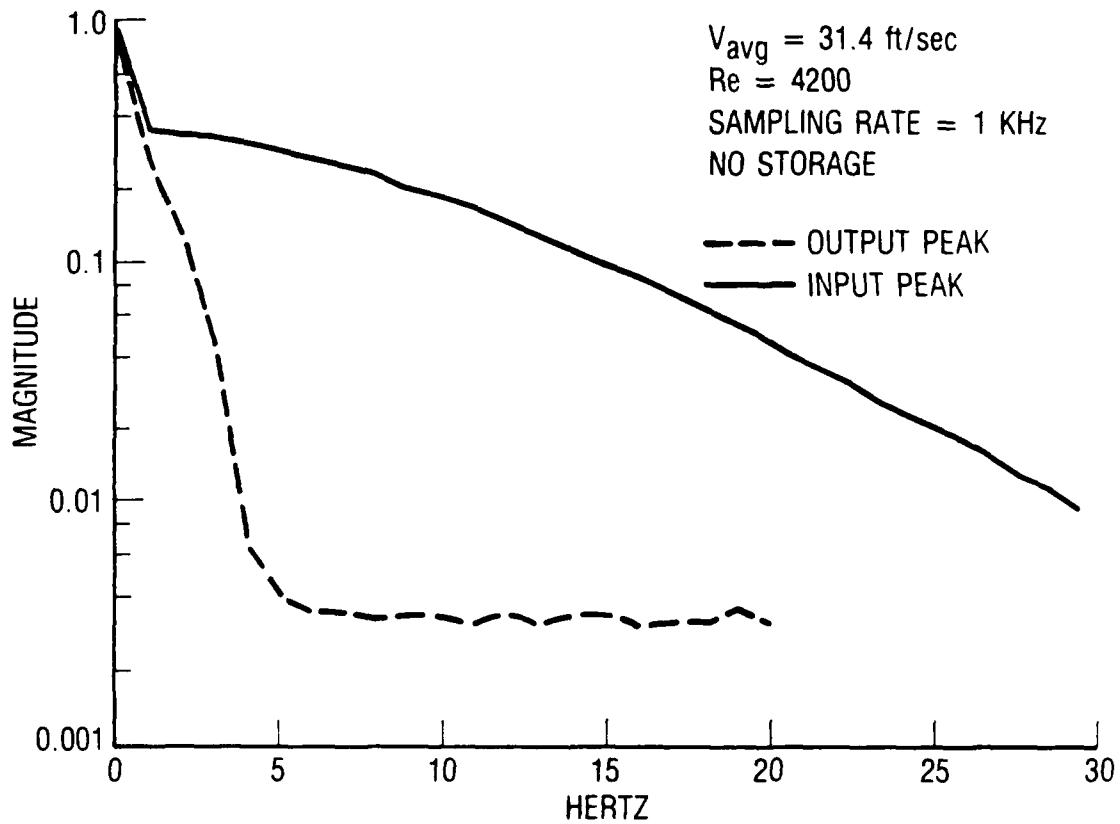

Fig. 7. Fourier Transform Analysis of the Input and Output Peaks Shown in Figs. 5 and 6. Since there is little hope of successfully applying corrections greater than 100, the frequency cutoff for the 3/8 in., 300 ft memory tube is approximately 4 Hz.

resulting transfer function (frequency response curve of the tube) is shown in Fig. 8. Similar data were obtained for 1/4 in. tubes and also for a 75 ft long, 3/8 in. tube. The transfer function for the 75 ft tube is shown in Fig. 9. Note that Figs. 1 through 9 are for oxygen pulses in nitrogen.

Because helium is closer to hydrogen in diffusivity, we used helium pulses in nitrogen to study the effect of storage time on the frequency response of the memory tubes. The transfer function of a 3/8 in., 300 ft long tube for helium is shown in Fig. 10 for a prompt analysis and in Fig. 11 for analysis after 1 hr of storage.

The minimal loss of information suffered in 60 min storage suggests that (1) 75 ft memory tubes will still provide 9-10 Hz resolution after 1 hr of storage and (2) frequency compensation may be successfully extended to samples stored for longer periods. Longer storage intervals would permit more sampling locations in the duct with a subsequent increase in resolution.

To obtain meaningful Fourier transforms, we had to acquire data with a sampling rate and vertical resolution much greater than the 50 Hz, 10 bit resolution supplied with the mass spectrometer. Data were taken using the Norland storage oscilloscope with a 1 KHz sampling rate and 12 bit resolution. Without these improvements, the Fourier transforms were dominated by artifacts and were not useful.

In applying Fourier analysis to gas peaks, we are assuming that the time dependent hydrogen concentration can be expressed by the series

$$C(t) = a_0 + a_1 \sin w_1 t + a_2 \sin w_2 t + \dots \quad (5)$$

where  $w_n$  is the frequency, and  $a_n$  is the Fourier co-efficient at the frequency  $w_n$ . We expect to truncate Eq. (5) at a frequency component determined by the resolution of the

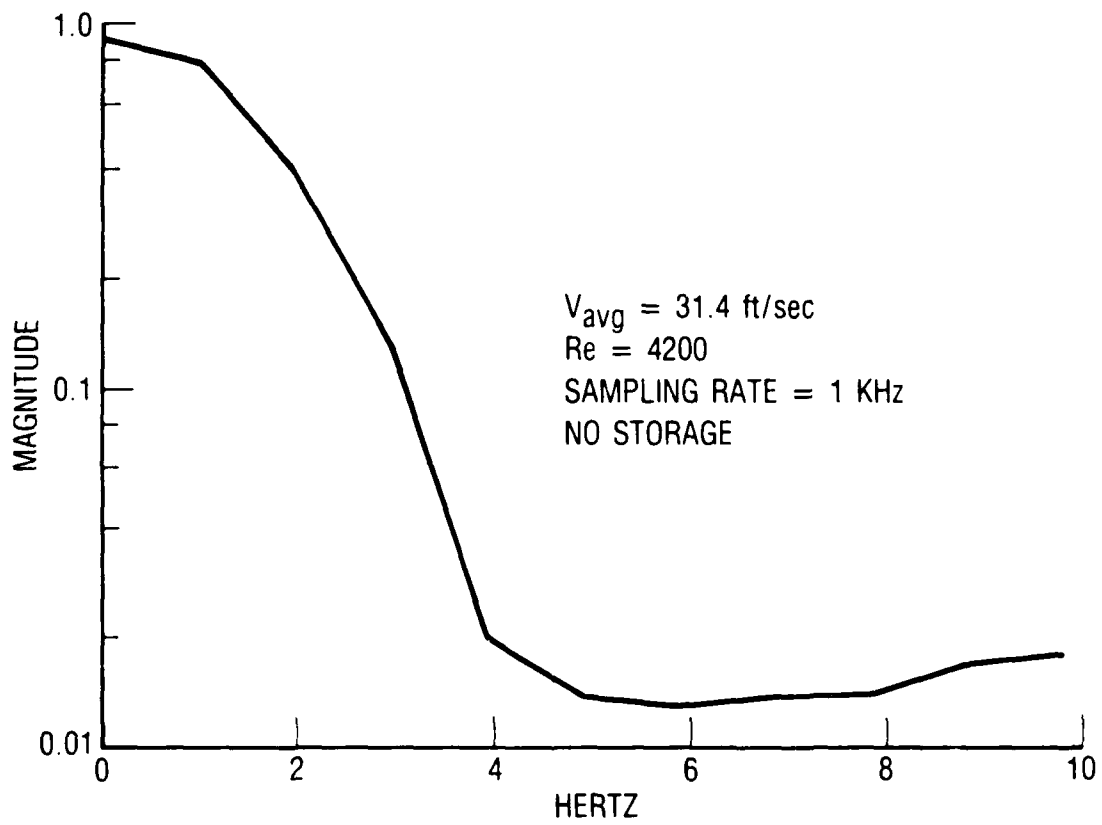

Fig. 8. Experimental Transfer Function for the 3/8 in., 300 ft Memory Tube Showing the 4 Hz Frequency Cutoff

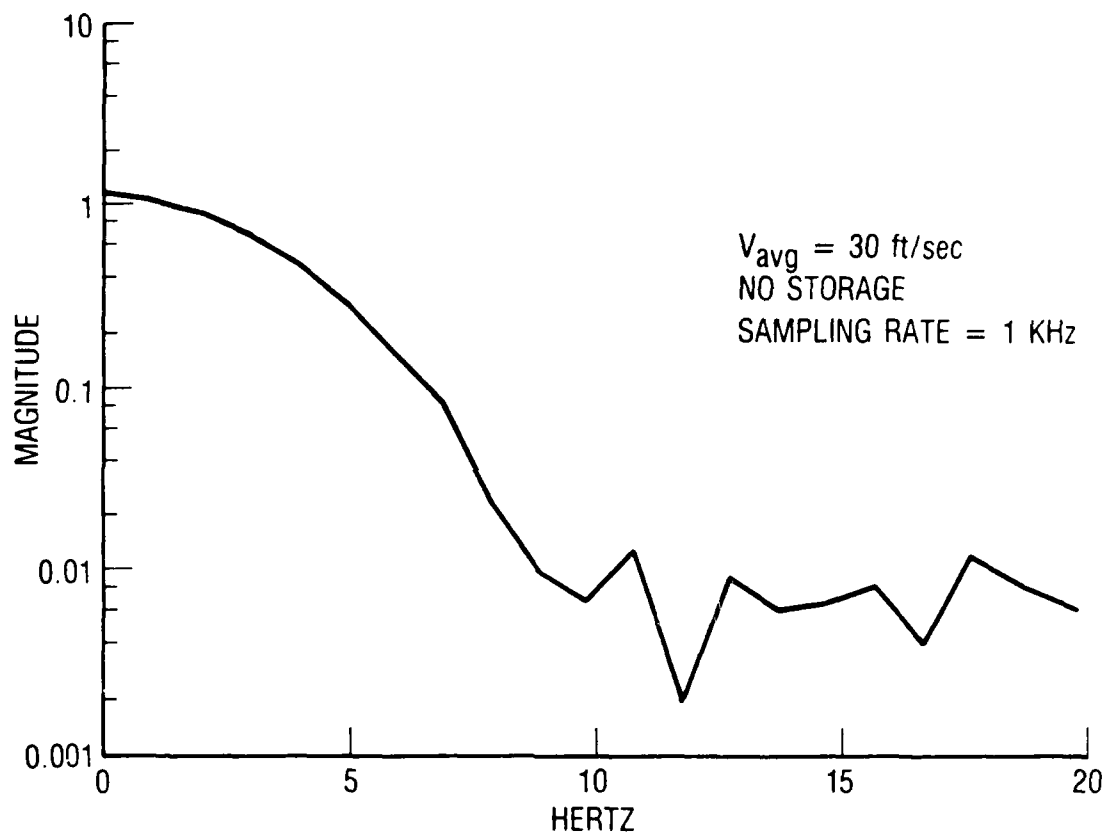

Fig. 9. Experimental Transfer Function for the 3/8 in., 75 ft Memory Tube Showing the 10 Hz Frequency Cutoff

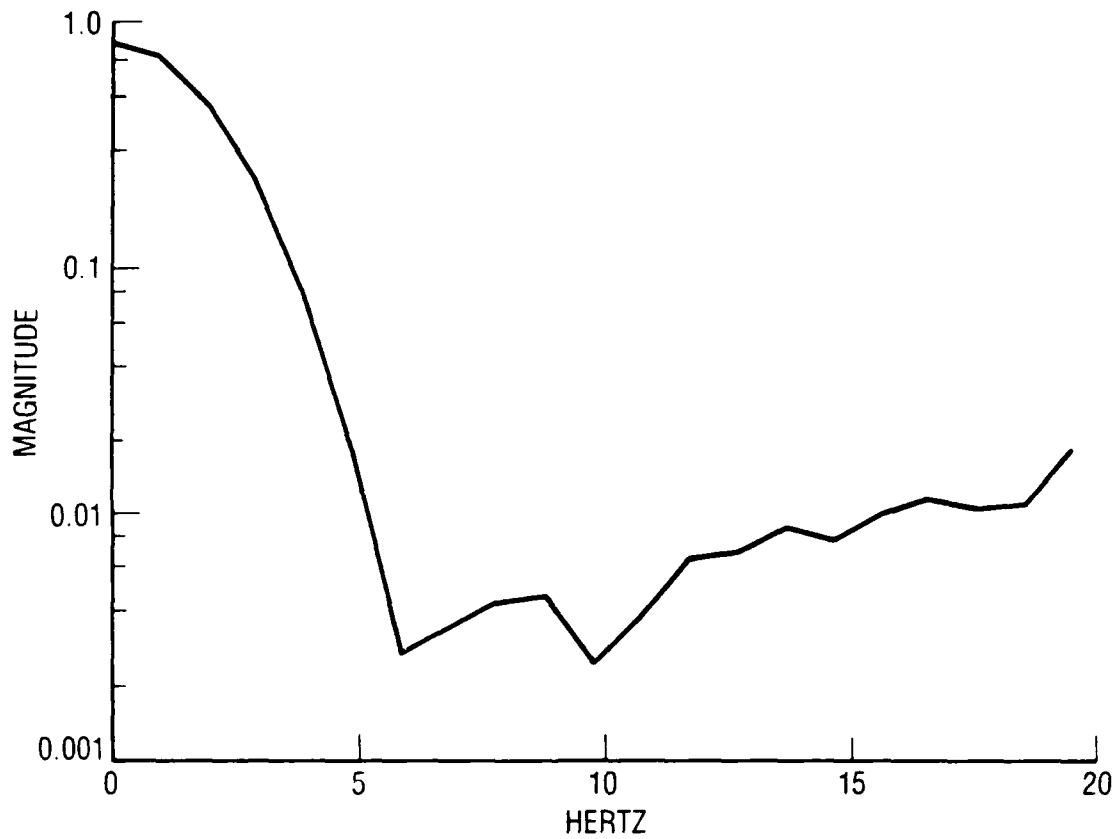

Fig. 10. Experimental Transfer Function for the 3/8 in., 300 ft Memory Tube Using Helium with No Storage. Note the slight increase in frequency response over oxygen.

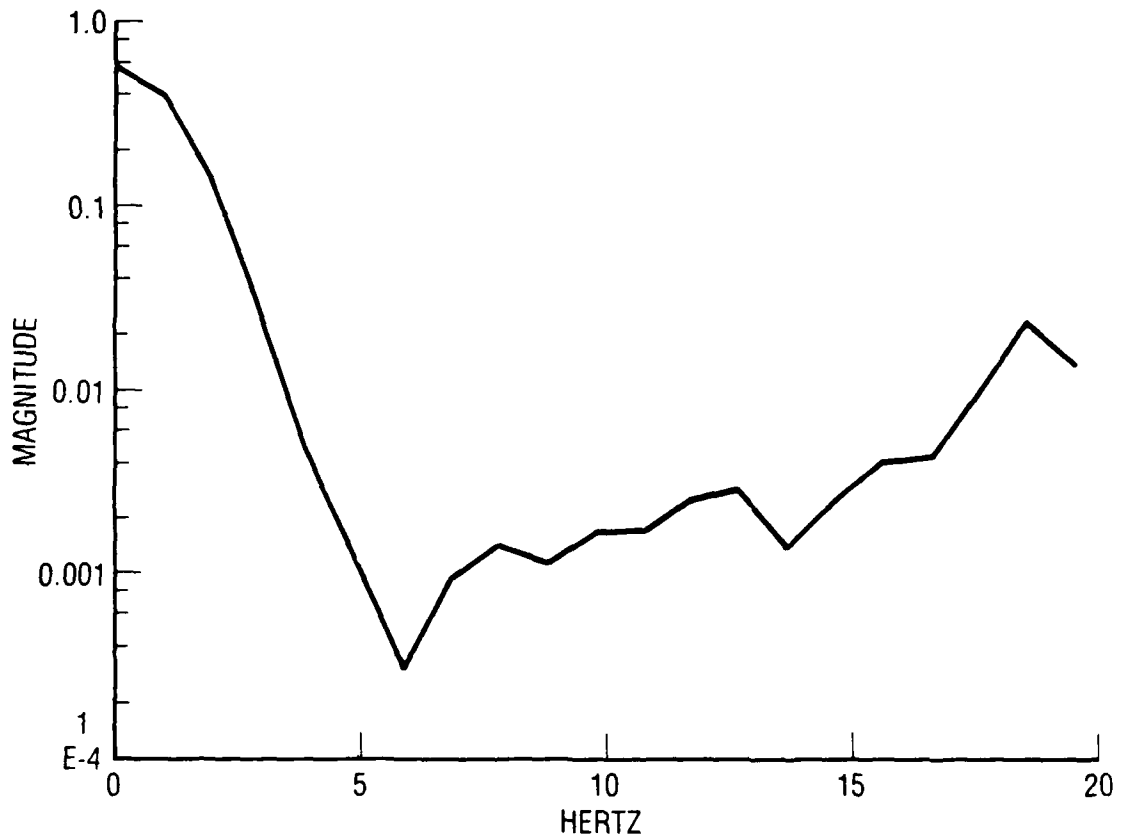

Fig. 11. Experimental Transfer Function for the 3/8 in., 300 ft Memory Tube Using Helium Stored for 1 hr Showing Only a Minor Effect on Frequency Response

memory tube, so that a potentially dangerous situation in the exhaust duct can be identified. One expects from the Taylor theory that narrow input pulses will become Gaussian in shape after passing through the tube. Because the Fourier transform of a Gaussian pulse is also Gaussian in shape, the transfer function should have the form

$$C_i(f) = C_o(f) e^{- (6.28*f/U)^2 K t} \quad (6)$$

where  $f$  is the frequency,  $U$  is the mean fluid velocity,  $K$  is the virtual diffusion coefficient,  $t$  is the transit time,  $C_o$  is the Fourier coefficient of the output peak, and  $C_i$  is the calculated input Fourier coefficient. We calculate an experimental transfer function by dividing the Fourier components of the output mass spectrum by the Fourier components of the input mass spectrum. We obtain the Gaussian transfer function by fitting the experimental transfer function to Eq. (6), using  $K$  as an adjustable parameter. The result is an average diffusion coefficient that reflects the diffusion during fill, storage, and read. We then calculate all  $C_i$  up to the resolution of the memory tube.

The Gaussian transfer function ( $K = 0.99$ ) agrees very well with the experimental transfer function when the sample is not stored. The theoretical and experimental curves for an unstored sample are compared in Fig.12. This encouraging result implies that our Gaussian transfer function is a valid assumption within the resolution of the memory tube. With 60 min storage, the fit to Eq. (6) ( $K = 1.77$ ), shown in Fig. 13, is less perfect. The rapid attenuation of the experimental transfer function in the 4-5 Hz region suggests that the input coefficients calculated from Eq. (6) may need further correction for non-Gaussian effects during storage.

Reconstruction of input data from output data, known as deconvolution, may be done by dividing the Fourier transform of the output by the transfer function and then by taking the

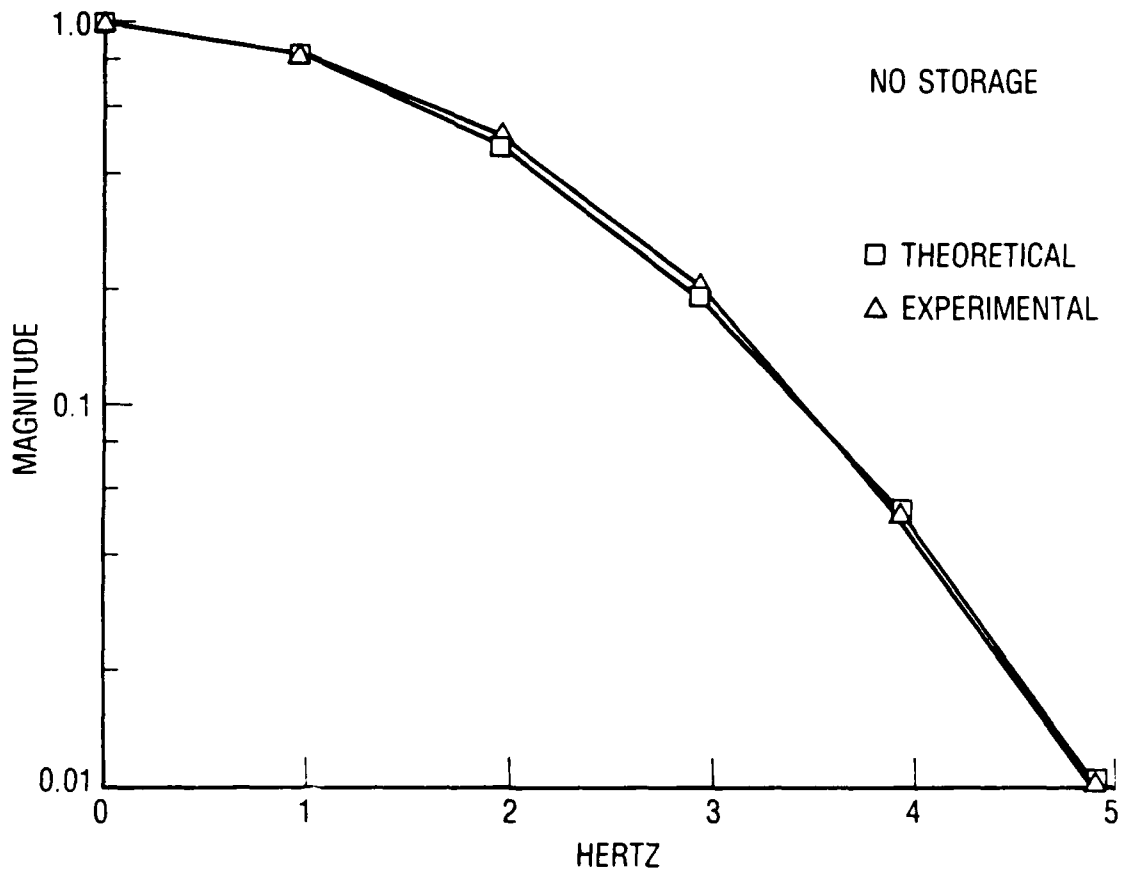

Fig. 12. Theoretical Fit to an Experimental Transfer Function Using Eq.(6) ( $K = 0.99$ ) for an Unstored Oxygen Sample. The excellent agreement suggests that Gaussian theory offers considerable insight into memory tube dynamics.

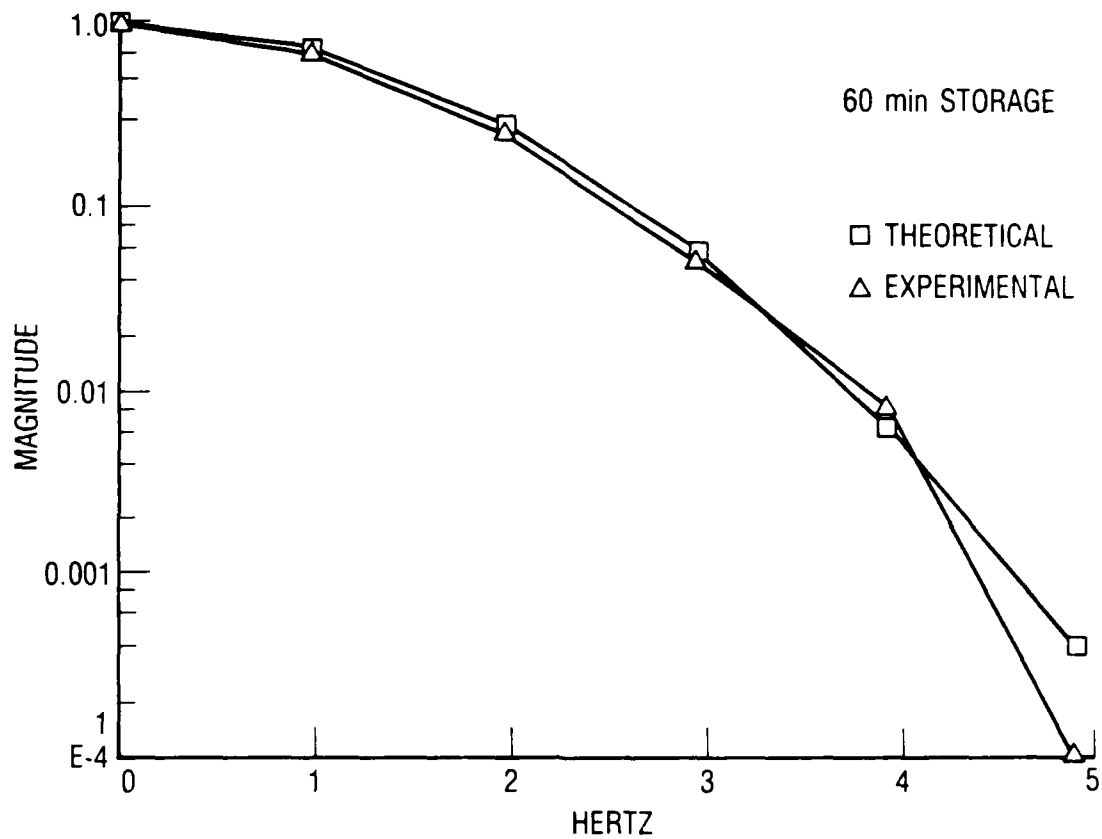

Fig. 13. Theoretical Fit to an Experimental Transfer Function Using Eq. (6) ( $K = 1.70$ ) for an Oxygen Sample Stored for 1 hr. The rather rapid attenuation of the highest frequency component suggests that Eq.(6) should probably be corrected for Non-Gaussian behavior during storage.

inverse Fourier transform of the result. This calculation is equivalent to dividing time dependent output data by the frequency response of the tube. To keep noise in this process under control, the frequency domain must be truncated at an acceptable noise level. The frequencies used in the deconvolution must be restricted to those below the "noise sea," seen as a horizontal lower limit in the transfer function plots. For the 1/4 in., 300 ft tubes (data not shown), this restricts frequency compensation to about 4 Hz. For the 3/8 in., 300 ft tubes, the frequency compensation limit is about 5 Hz, and for the 75 ft tubes, the frequency compensation limit is about 9 Hz. Figure 14 shows a reconstructed oxygen input from the 75 ft memory tube using Eq. (6).

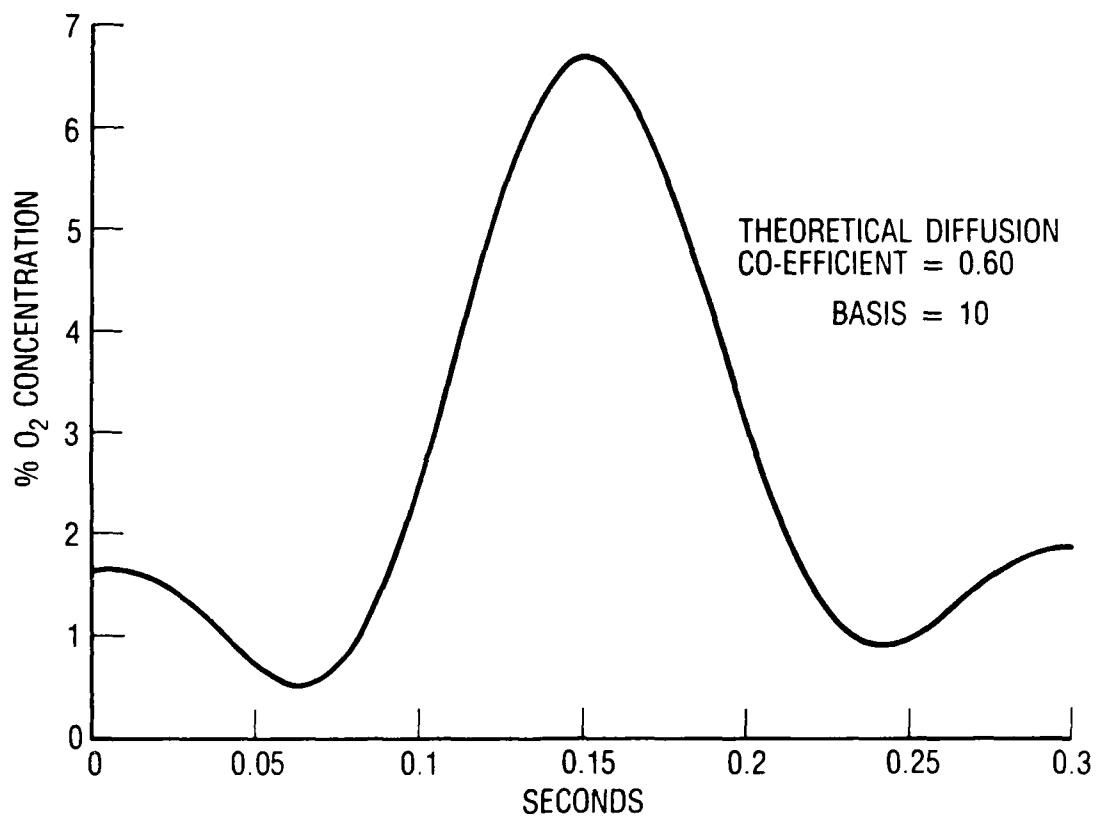

Fig. 14. Reconstructed Oxygen Sample for the 3/8 in., 75 ft Memory Tube Using 10 Basis Functions in the Fourier Series. Note the 0.100 sec Peak Width Indicating 10 Hz Resolution.

#### REFERENCES

1. G.I. Taylor, Proc. Roy. Soc. A 219, 186 (1953).
2. G.I. Taylor, Proc. Roy. Soc. A, 225, 473 (1954).