

U

DTIC FILE COPY



SECT

AD-A197 672

MENTATION PAGE

Form Approved
OMB No. 0704-0188

1a. REPORT SECURITY CLASSIFICATION Unclassified		1b. RESTRICTIVE MARKINGS	
2a. SECURITY CLASSIFICATION AUTHORITY		3. DISTRIBUTION / AVAILABILITY OF REPORT Approved for public release, distribution is unlimited	
2b. DECLASSIFICATION / DOWNGRADING SCHEDULE		4. PERFORMING ORGANIZATION REPORT NUMBER(S)	
4. PERFORMING ORGANIZATION REPORT NUMBER(S)		5. MONITORING ORGANIZATION REPORT NUMBER(S)	
6a. NAME OF PERFORMING ORGANIZATION US Army Rsch Inst of Env Med Natick, MA 01760-5007	6b. OFFICE SYMBOL (if applicable) SGRD-UE-AR	7a. NAME OF MONITORING ORGANIZATION	
6c. ADDRESS (City, State, and ZIP Code)		7b. ADDRESS (City, State, and ZIP Code)	
8a. NAME OF FUNDING / SPONSORING ORGANIZATION	8b. OFFICE SYMBOL (if applicable)	9. PROCUREMENT INSTRUMENT IDENTIFICATION NUMBER	
8c. ADDRESS (City, State, and ZIP Code)		10. SOURCE OF FUNDING NUMBERS	
		PROGRAM ELEMENT NO. 3M161102B	PROJECT NO. S15 WORK UNIT ACCESSION NO. 041
11. TITLE (Include Security Classification) An Apparatus for Collection of Cerebrospinal Fluid in Goats			
12. PERSONAL AUTHOR(S) V. Forte, Jr., J. Devine, A. Cyerman			
13a. TYPE OF REPORT Manuscript	13b. TIME COVERED FROM _____ TO _____	14. DATE OF REPORT (Year, Month, Day) 88 March	15. PAGE COUNT 14
16. SUPPLEMENTARY NOTATION			
17. COSATI CODES		18. SUBJECT TERMS (Continue on reverse if necessary and identify by block number)	
FIELD	GROUP	SUB-GROUP	
19. ABSTRACT (Continue on reverse if necessary and identify by block number) A lightweight, adjustable, apparatus has been designed to standardize and advance the technology for chronic cannula implantation in <u>Capra licrus</u> (goats). The adapter facilitates cannula implantation, improves surgical procedures and enhances the probability of successful cannulation with minimal risk to the animal. This report describes the design, construction and specifications of the apparatus.			
20. DISTRIBUTION / AVAILABILITY OF ABSTRACT <input checked="" type="checkbox"/> UNCLASSIFIED/UNLIMITED <input type="checkbox"/> SAME AS RPT. <input type="checkbox"/> DTIC USERS		21. ABSTRACT SECURITY CLASSIFICATION Unclassified	
22a. NAME OF RESPONSIBLE INDIVIDUAL Vincent A. Forte, Jr.		22b. TELEPHONE (Include Area Code) (617) 651-2828	22c. OFFICE SYMBOL SGRD-UE-AR

DTIC
SELECTED
JUL 26 1988
D
E

AN APPARATUS FOR COLLECTION OF CEREBROSPINAL FLUID IN GOATS

Vincent Forte, Jr.

James Devine

Allen Cymerman

Accession For	
NTIS GRA&I	<input checked="" type="checkbox"/>
DTIC TAB	<input type="checkbox"/>
Unannounced	<input type="checkbox"/>
Justification	
By	
Distribution/	
Availability Codes	
Dist	Avail and/or Special
A-1	



FOREWARD

Citations of commercial organizations and trade names in this report do not constitute an official Department of the Army endorsement or approval of the products or services of these organizations.

The views, opinions, and/or findings contained in this report are those of the authors and should not be construed as official Department of the Army position, policy, or decision, unless so designated by other official documentation.

ABSTRACT:

A lightweight, adjustable, apparatus has been designed to standardize and advance the technology for chronic cannula implantation in Capra licrus (goats). The adapter facilitates cannula implanation, improves surgical procedures and enhances the probability of successful cannulation with minimal risk to the animal. This report describes the design, construction and specifications of the apparatus.

INTRODUCTION

An apparatus has been designed to standardize and advance the technology for chronic cannula implantation in Capra lircus (goats). Cannulas have been permanently implanted in the lateral ventricles and cisterna magna of goats following the technique described by Pappenheimer et al. (1). Research has been directed at changes in composition of the cerebrospinal fluid (CSF) surrounding the chemoreceptors for explaining environmental (hypobaria) adaptive changes in pulmonary ventilation (2-5). The apparatus is designed to provide an accurate, safe means of continuous perfusion of synthetic CSF through ventricular cannula and sampling actual CSF through the cisternal cannula of unanesthetized goats.

While the preparations, operative procedures, and research applications have been described earlier by Pappenheimer, it is the purpose of this report to outline the design, construction and specifications of the apparatus. The device facilitates cannula implantation, standardizes surgical procedures and enhances the probability of successful surgical cannulation with minimal risk to the animal.

MATERIALS AND METHODS

Four research studies were performed using the specialized instruments for cannula implantation (2-5). These studies successfully utilized the apparatus described below for chronic cannula implantation and CSF sampling in goats. The principal items of the apparatus described are: 1) the nylon guide tubes (cannulas) implanted above the dura and in the cisterna magna just above the ependymal linings of the lateral ventricles and, 2) a needle adapter to expedite dura puncture for CSF sampling are detailed.

IMPLANTATION OF THE CISTERNAL GUIDE TUBE: Prior to implantation of the cisternal cannula, a hole is trephined down through the base of the occipital bone overlying the dura mater above the foramen magnum (1). A channel is rongeured from the base of the hole dorsally to the nuchal crest. Two orthopedic (stainless steel) screws are placed on each side of the channel with a third placed on the rostral end of the nuchal crest. The cisterna magna cannula is machined from a solid piece of .375 in diameter nylon dowel (Micro Group Inc.) and placed into the channel allowing the 45° angle cut of the cannula foot to lie directly on the dura mater (Fig. 1A).

Gel foam (UpJohn Co.) is used to protect the dura prior to the application of the more permanent dental acrylic (Hygenic Dental Mfg. Co., "Perm"). The gel foam is later reabsorbed by the tissues. The dental acrylic is poured around the cannula and over the screws used for anchoring the resin. A stereo-taxic device, described by Pappenheimer (1), supports the cannula until the dental acrylic has been cured. The cannula is designed with circumferential grooves and a flat surface on one side to prohibit rotation and longitudinal movements. After the acrylic has set (15 minutes), the subcutaneous tissue and skin are brought around the cannula and sutured to complete the surgical procedure. The cannula is then capped with a locking obturator seen in Fig. 1B.

The obturator is a stainless steel rod (.042 in) that is silver soldered into a closed-end male leurlok adapter. The opposite end of the obturator is rounded and fits flush with the angular foot of the cannula when fully inserted. The primary use of the obturator is to protect the cannula from airborne contaminants, and to clean the tube of percutaneous matter that may act to plug the base of the cannula when the cistern puncture needle is extracted.

IMPLANTATION OF VENTRICULAR GUIDE TUBE: The lateral ventricular cannula (Fig. 2A) is introduced through a hole trephined in the parietal bone. It is then supported with stereo-taxic equipment while the dental acrylic cement is applied similarly to the procedure for installing the cisternal cannula. The coordinates and surgical procedures for ventricular catheterization have been described earlier by Pappenheimer et al. (1). The cannula design is similar to the cisternal cannula with circumferential grooves and a flat surface on one side to prohibit rotation and longitudinal movements. The long narrow tip is

specially designed to puncture the tissue mass covering the dura.

During actual research procedures artificial CSF is profused through the ventricular cannula while native CSF is collected from the cisternal cannula. The cannula is then capped with a locking obturator seen in Fig. 2B.

SPINAL NEEDLE ADAPTER: Prior to the cistern puncture, the animal is placed in a stanchion designed to restrict head movement (7). A blunt stainless steel measuring rod (similar to the obturator) is inserted through the cannula until it touches the dura, the rod is subsequently marked with a depth indicator (sterile hemostat) at the top of the nylon guide tube. The rod is removed and measured for puncture depth using the scale of millimeters (mm) on a machinist's rule. The assembled spinal needle adapter is then fitted to the top of a 19 gauge spinal needle (Fig. 5) with the split-collar course adjustment (Fig.3) unit toward the back end. With the fine adjustment luer extension (fig.4) threaded fully inward, the adapter is positioned 6-8 mm above the depth indicator line and secured to the needle using the coarse adjustment screw. Next, the luer-slip fine adjustment is unthreaded down the needle shaft to within 1 mm of the indicator line to compensate for the dura thickness. The needle is then inserted into the guide tube and the dura is punctured using a quick gentle motion. If the puncture is unsuccessful, the needle depth is increased by simply threading in clockwise the fine adjust luer-slip an additional 0.5 - 1 mm and repeating the procedure. Pressure is placed on each side of the neck to occlude the external jugular veins and increase CSF pressure during puncture. The needle adapter allows a single needle length change adjustment as opposed to the former practice of using multiple needles each of different lengths. The adapter also assures an accurate puncture depth

preventing accidental damage to surrounding tissues. The adjustable length of the spinal needle adaptor is 38 mm when the fine adjust luer-slip is threaded in fully and 44 mm when extended. Adjustable spinal needle adaptors are used with both cannula for tapping their respective fluid departments. The same techniques and procedures employed for puncturing the dura through the cisternal guide tube are used to puncture the dura through the ventricular guide tube as described above.

DISCUSSION

The operative procedures and techniques of perfusion and CSF sampling have been developed over many years by Pappenheimer and others (1-6). This report describes a new apparatus designed to improve cannula implantation and dura puncturing procedures. The new instrumentation provides a complete system, that permits laboratory machine shop reproductions. Such apparatus have been successfully used for perfusion and CSF sampling over a period of years and the animals remained in good health during repeated studies.

ACKNOWLEDGEMENTS:

The authors wish to thank draftsman SGT. William Sawyer for his excellent mechanical drawings and Mr. William Letourneau for fabrication of prototype.

FIGURE

LEGEND

- 1A Cisternal Guide Tube and Locking Obturator
with Dimensional Data
- 1B An Intact View of the Cisternal Cannula
- 2A Ventricular Guide Tube and Locking Obturator
with Dimensional Data
- 2B An Intact View of the Ventricular Cannula
- 3 Fine Adjustment Leur Extension with Dimensional
Data
- 4 Split-Collar Course Adjustment with Locking
Assembly and Dimensional Data
- 5 Exploded View of the Spinal Needle Adapter
with Relation to the Assembled Unit

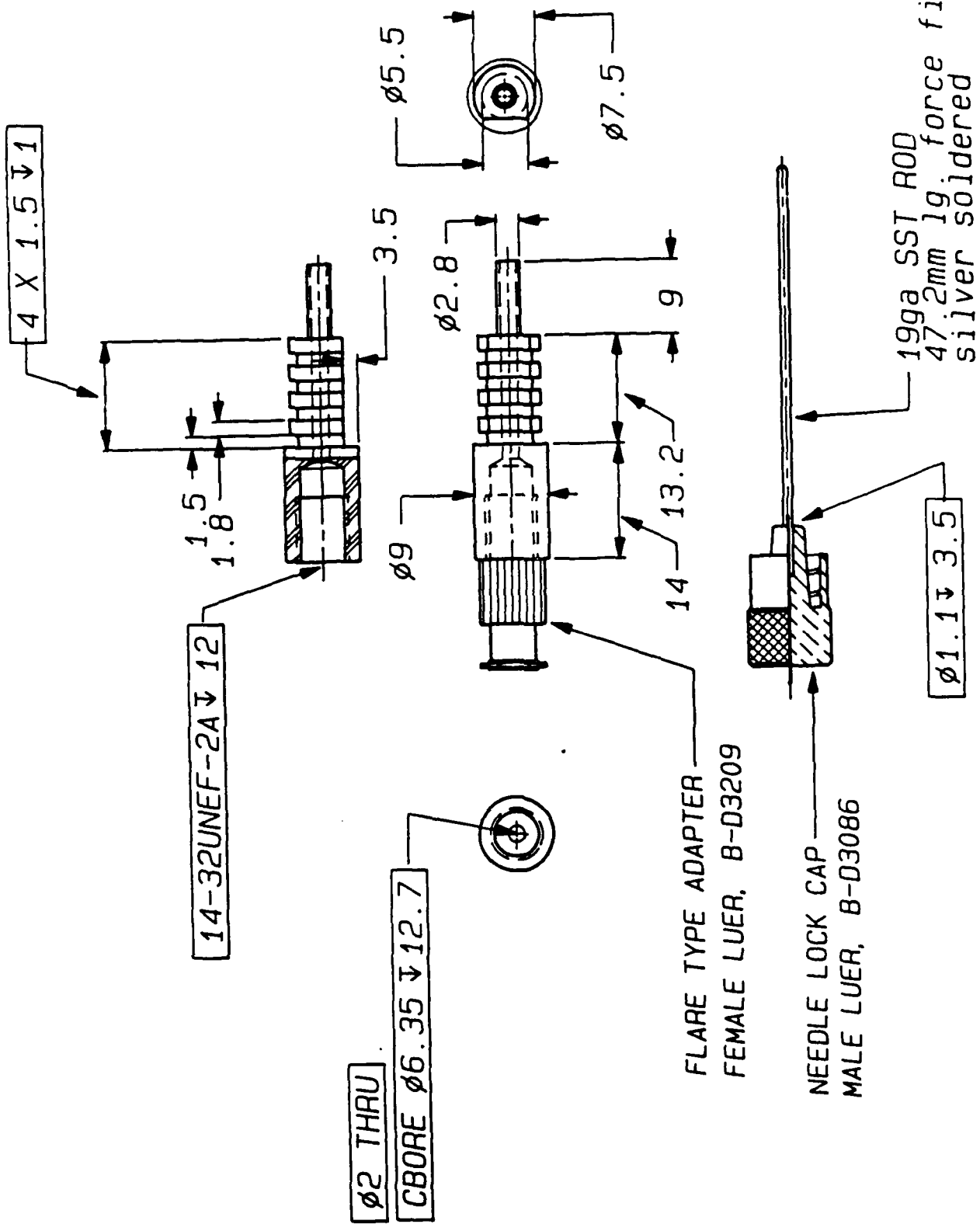

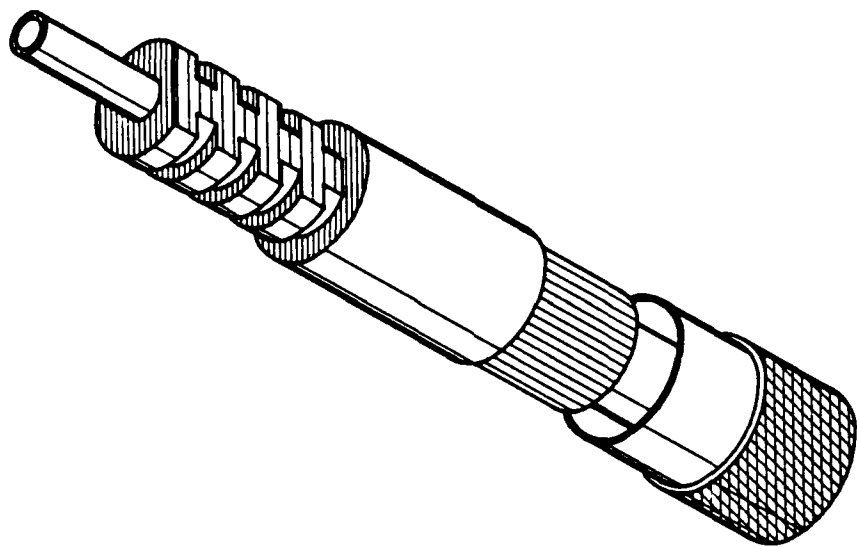

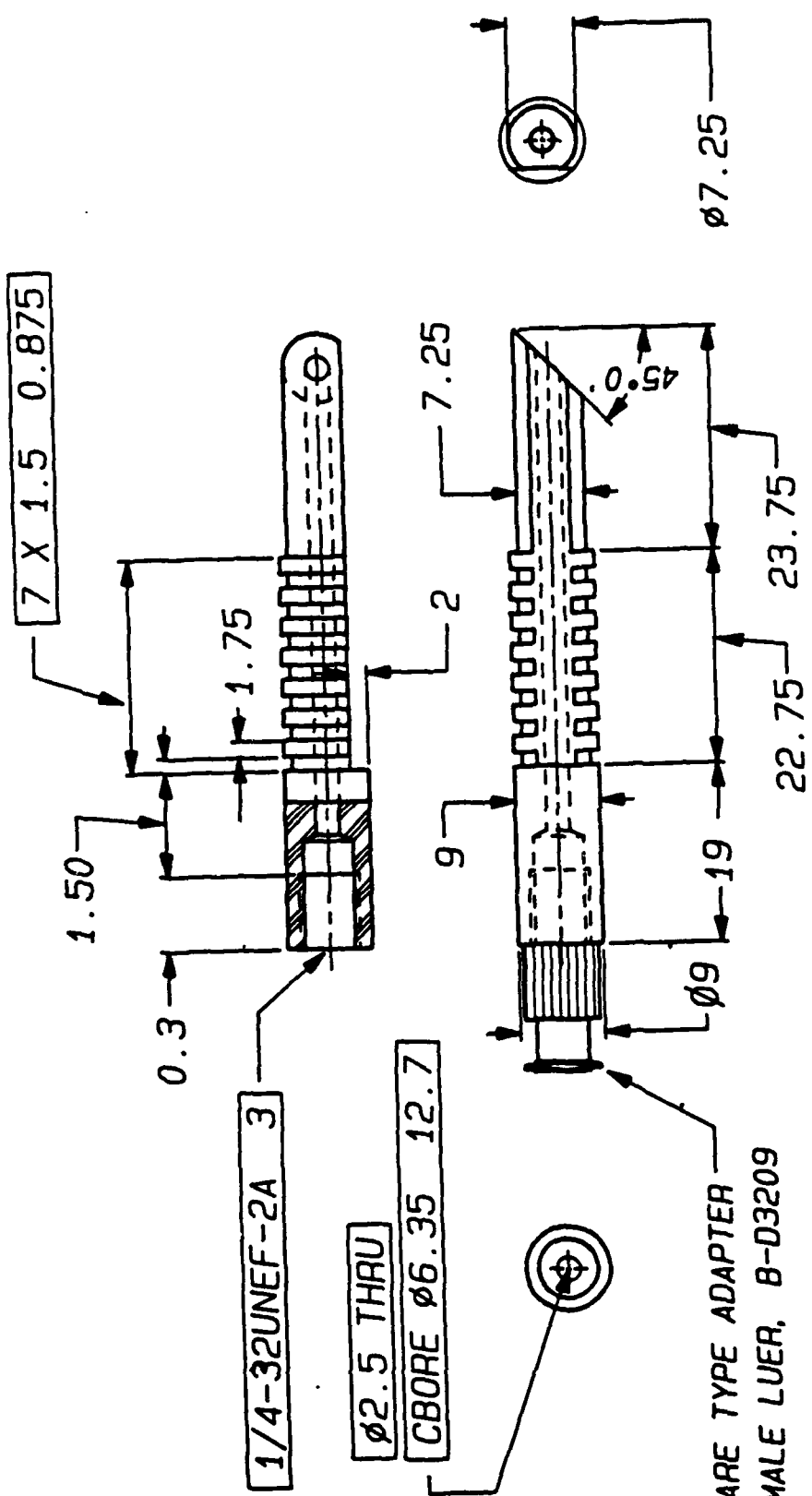

FLARE TYPE ADAPTER
FEMALE LUER, B-D3209

NEEDLE LOCK CAP
MALE LUER, B-D3086

16ga SST ROD
74mm lg, force fit
silver soldered

$\phi 1.588 \ 3.5$

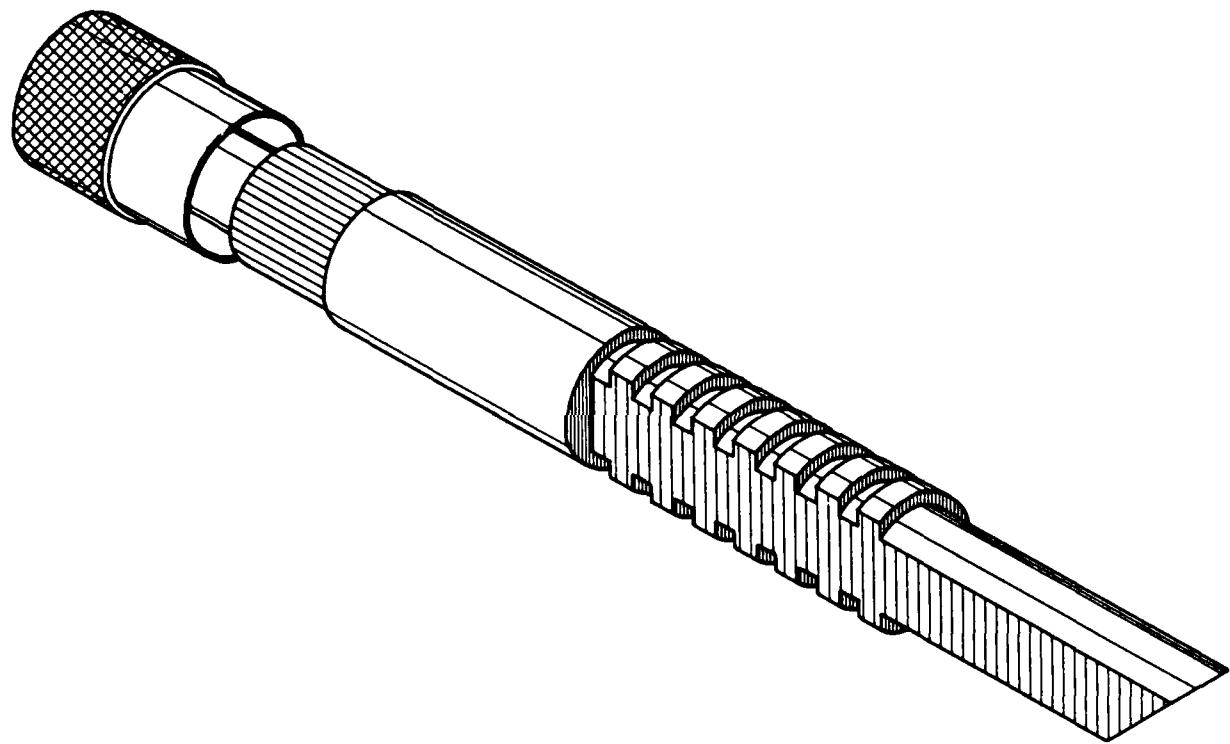

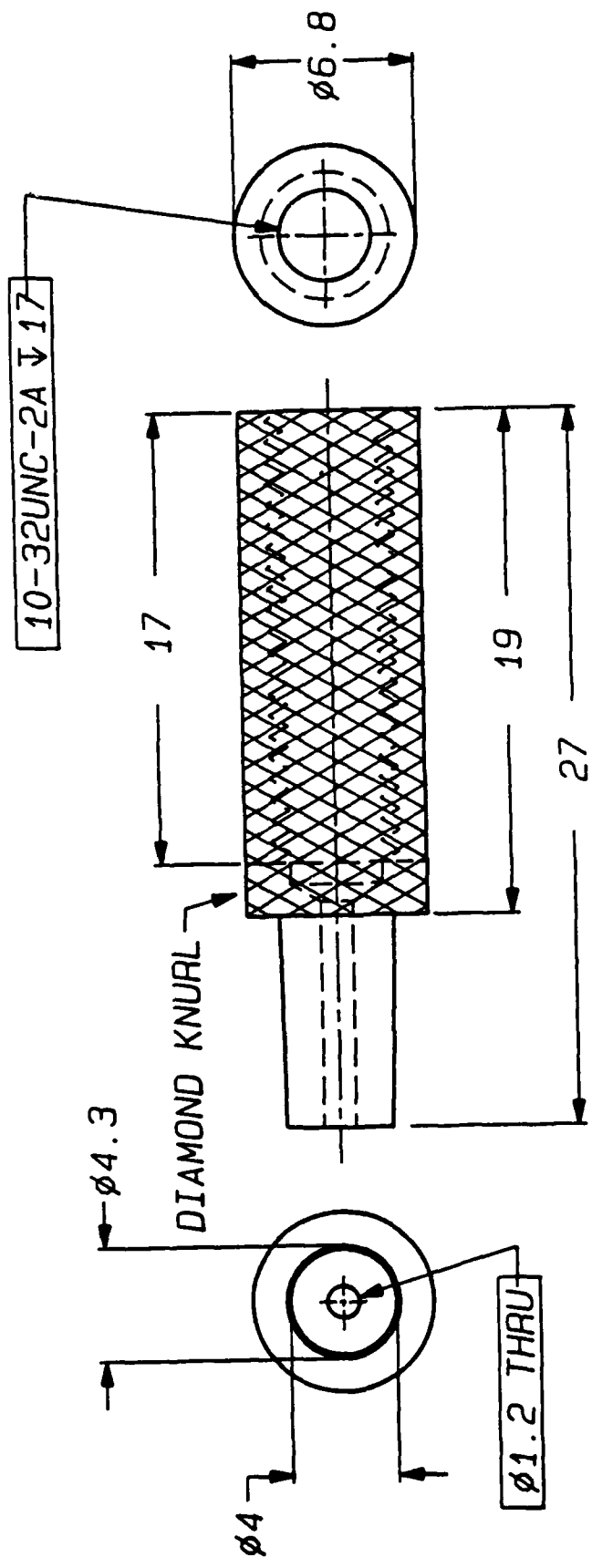

MATERIAL: BRASS

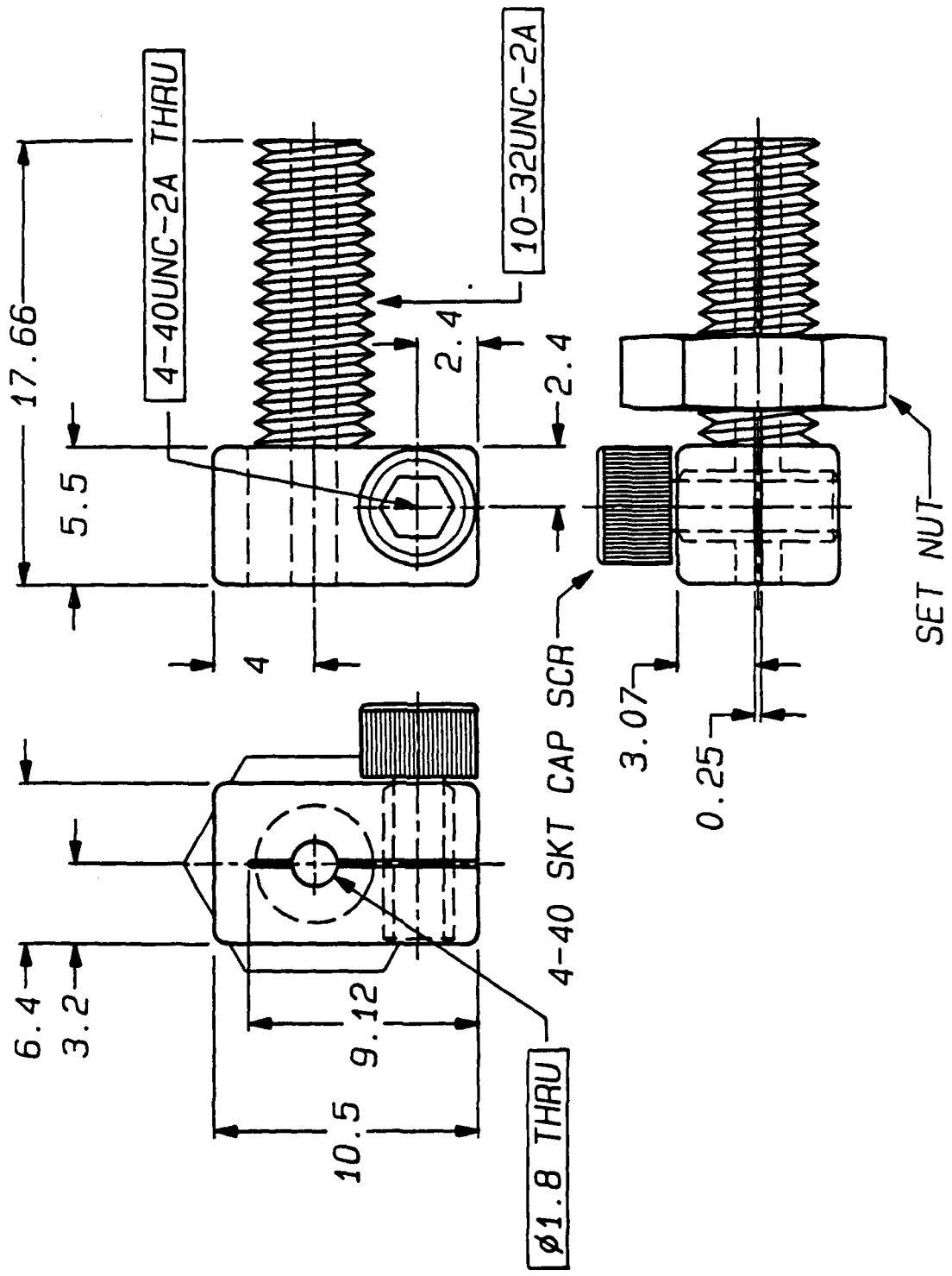

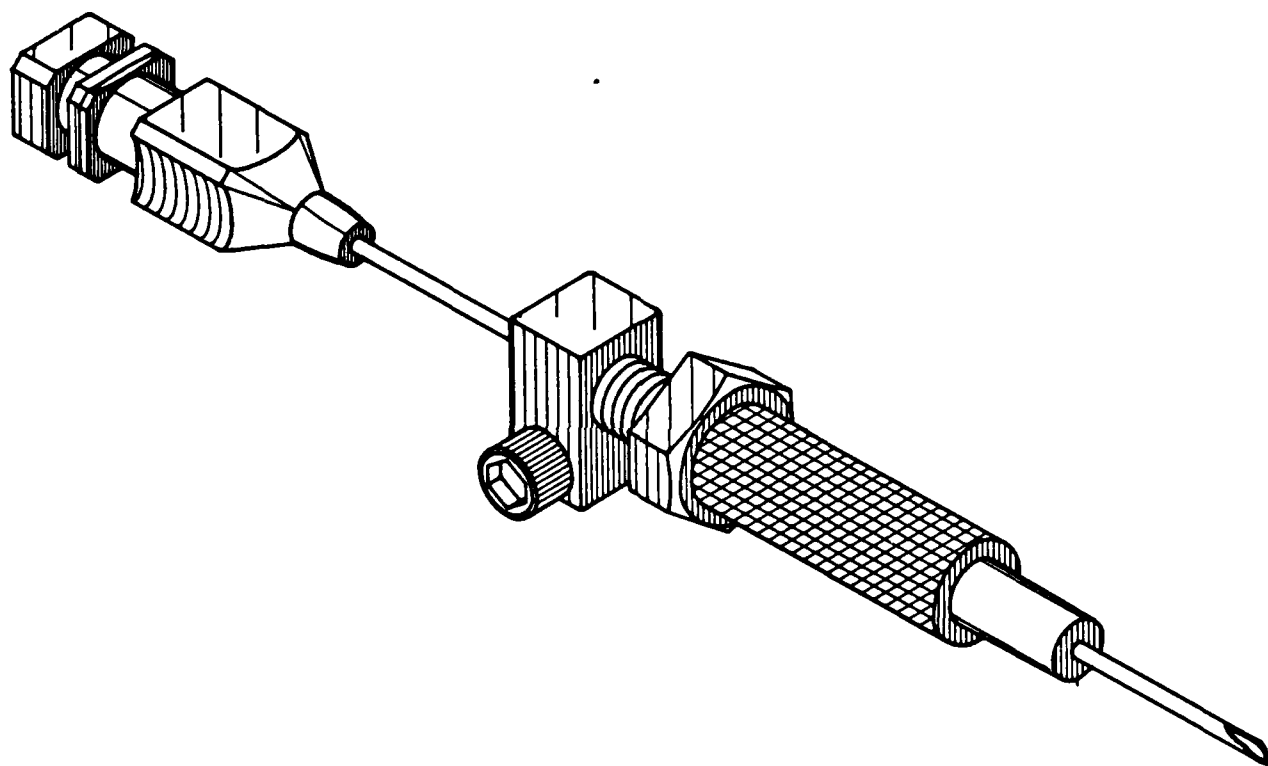

REFERENCES

1. Pappenheimer, J.R., S.R. Heisey, E.F. Jordon, and J. deC. Downer. Perfusion of the cerebral ventricular system in unanesthetized goats. *Am. J. Physiol.* 203(5); 763-774, 1962.
2. Fencl, V., R.A. Gabel, and D. Wolfe. Composition of cerebral fluids in goats adapted to high altitude. *J. Appl. Physiol.: Respirat. Environ. Exercise Physiol.* 47(3); 508-513, 1979.
3. Steinbrook, R.A., J.C. Donovan, R.A. Gabel, D.E. Leith, and V. Fencl. Acclimatization to high altitude in goats with ablated carotid bodies. *J. Appl. Physiol.: Respirat. Environ. Exercise Physiol.* 55(1); 16-21, 1983.
4. Steinbrook, R.A., S. Javaheri, R.A. Gabel, J.C. Donovan, D.E. Leith, and V. Fencl. Respiration of chemodenervated goats in acute metabolic acidosis. *Respir. Physiol.* 56, 51-60, 1984.
5. Weinberger, S.E., R.A. Steinbrook, D.A. Carr, V. Fencl, R.A. Gabel, D.E. Leith, J.E. Fisher, R. Harris, and M. Rosenblatt. Endogenous opioids and ventilatory adaptation to prolonged hypoxia in goats. *Life Sci.* 40, 605-613, 1986.
6. Hamilton, A.J., P.M. Black, J. Madsen, and D.B. Carr. Neuropeptide investigations with an ovine surgical model. *Neurosurgery* 18: 748-755, 1986.
7. Forte, V.A. Jr., J.D. Devine, and A. Cymerman. Research animal stanchion and transporter. *Lab. Anim. Sci.* (accepted for publication 1988).

REFERENCES

1. Pappenheimer, J.R., S.R. Heisey, E.F. Jordon, and J. deC. Downer. Perfusion of the cerebral ventricular system in unanesthetized goats. *Am. J. Physiol.* 203(5); 763-774, 1962.
2. Fencl, V., R.A. Gabel, and D. Wolfe. Composition of cerebral fluids in goats adapted to high altitude. *J. Appl. Physiol.: Respirat. Environ. Exercise Physiol.* 47(3); 508-513, 1979.
3. Steinbrook, R.A., J.C. Donovan, R.A. Gabel, D.E. Leith, and V. Fencl. Acclimatization to high altitude in goats with ablated carotid bodies. *J. Appl. Physiol.: Respirat. Environ. Exercise Physiol.* 55(1); 16-21, 1983.
4. Steinbrook, R.A., S. Javaheri, R.A. Gabel, J.C. Donovan, D.E. Leith, and V. Fencl. Respiration of chemodenervated goats in acute metabolic acidosis. *Respir. Physiol.* 56, 51-60, 1984.
5. Weinberger, S.E., R.A. Steinbrook, D.A. Carr, V. Fencl, R.A. Gabel, D.E. Leith, J.E. Fisher, R. Harris, and M. Rosenblatt. Endogenous opioids and ventilatory adaptation to prolonged hypoxia in goats. *Life Sci.* 40, 605-613, 1986.
6. Hamilton, A.J., P.M. Black, J. Madsen, and D.B. Carr. Neuropeptide investigations with an ovine surgical model. *Neurosurgery* 18: 748-755, 1986.
7. Forte, V.A. Jr., J.D. Devine, and A. Cymerman. Research animal stanchion and transporter. *Lab. Anim. Sci.* (accepted for publication 1988).

END

DATE

FILMED

DTIC

9-88