

2

AD-A197 927

ECONOMICAL INSULATION TESTS

Raymond W. Nethers
1Lt David W. Metzger
Albert B. Griffin

July 1988

Final Report

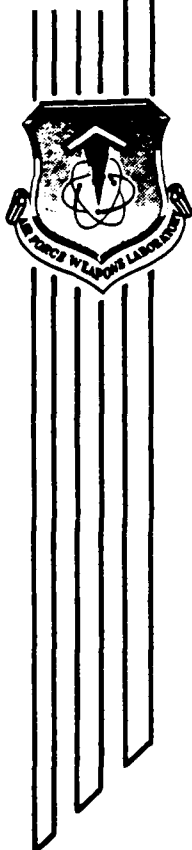

Approved for public release; distribution unlimited.

DTIC
ELECTE
AUG 19 1988
S H D

AIR FORCE WEAPONS LABORATORY
Air Force Systems Command
Kirtland Air Force Base, NM 87117-6008

88 8 18 088

This final report was prepared by the Air Force Weapons Laboratory, Kirtland Air Force Base, New Mexico under Job Order 12091501. Mr Raymond W. Nethers (NTAO) was the Laboratory Project Officer-in-Charge.

When Government drawings, specifications, or other data are used for any purpose other than in connection with a definitely Government-related procurement, the United States Government incurs no responsibility or any obligation whatsoever. The fact that the Government may have formulated or in any way supplied the said drawings, specifications, or other data, is not to be regarded by implication, or otherwise in any manner construed, as licensing the holder, or any other person or corporation; or as conveying any rights or permission to manufacture, use, or sell any patented invention that may in any way be related thereto.

This report has been authored by employees of the United States Government. Accordingly, the United States Government retains a nonexclusive, royalty-free license to publish or otherwise reproduce the material contained herein, or allow others to do so, for United States Government purposes.

This report has been reviewed by the Public Affairs Office and is releasable to the National Technical Information Service (NTIS). At NTIS, it will be available to the general public, including foreign nations.

If your address has changed, if you wish to be removed from our mailing list, or if your organization no longer employs the addressee, please notify AFWL/NTAO, Kirtland AFB, NM 87117-6008 to help us maintain a current mailing list.

This technical report has been reviewed and is approved for publication.



RAYMOND W. NETHERS
Project Officer



KENNETH N. COLE
Capt, USAF
Chief, Test Operations Branch

FOR THE COMMANDER



ALFRED L. SHARP
Chief, Aircraft & Missiles Div

DO NOT RETURN COPIES OF THIS REPORT UNLESS CONTRACTUAL OBLIGATIONS OR NOTICE ON A SPECIFIC DOCUMENT REQUIRES THAT IT BE RETURNED.

UNCLASSIFIED

SECURITY CLASSIFICATION OF THIS PAGE

REPORT DOCUMENTATION PAGE

1a. REPORT SECURITY CLASSIFICATION UNCLASSIFIED		1b. RESTRICTIVE MARKINGS	
2a. SECURITY CLASSIFICATION AUTHORITY		3. DISTRIBUTION/AVAILABILITY OF REPORT Approved for public release; distribution unlimited.	
2b. DECLASSIFICATION/DOWNGRADING SCHEDULE		4. PERFORMING ORGANIZATION REPORT NUMBER(S) AFWL-TR-88-40	
5. MONITORING ORGANIZATION REPORT NUMBER(S)		6a. NAME OF PERFORMING ORGANIZATION Air Force Weapons Laboratory	
6b. OFFICE SYMBOL (if applicable)		7a. NAME OF MONITORING ORGANIZATION	
6c. ADDRESS (City, State, and ZIP Code) Kirtland Air Force Base, NM 87117-6008		7b. ADDRESS (City, State, and ZIP Code)	
8a. NAME OF FUNDING/SPONSORING ORGANIZATION		8b. OFFICE SYMBOL (if applicable)	
8c. ADDRESS (City, State, and ZIP Code)		9. PROCUREMENT INSTRUMENT IDENTIFICATION NUMBER	
10. SOURCE OF FUNDING NUMBERS		11. TITLE (Include Security Classification) ECONOMICAL INSULATION TESTS	
PROGRAM ELEMENT NO. 64747F	PROJECT NO. 1209	TASK NO. 15	WORK UNIT ACCESSION NO. 01
12. PERSONAL AUTHOR(S) Nethers, Raymond W.; Metzger, 1st Lt David W.; and Griffin, Albert B.			
13a. TYPE OF REPORT Final		13b. TIME COVERED FROM 1Aug86 TO 6Aug86	
14. DATE OF REPORT (Year, Month, Day) 1988 July		15. PAGE COUNT 10	
16. SUPPLEMENTARY NOTATION			
17. COSATI CODES		18. SUBJECT TERMS (Continue on reverse if necessary and identify by block number)	
FIELD 20	GROUP 03	Electrical breakdown Standoff voltage Air arc insulation	
		Electrical discharge Electrical insulation, COST effective design (TES)	
19. ABSTRACT (Continue on reverse if necessary and identify by block number) Results of high voltage electrical discharge tests on various solid insulating material schemes for large gap insulation are reported along with test conduct. Six materials: plywood, polycarbonate, formica, styrofoam, polypropylene and mylar were tested singly, in multilayers, and in mixed multilayers. It was found that multilayer mylar gave the best improvement to gap holdoff while other materials actually degraded the holdoff. (K...)			
20. DISTRIBUTION/AVAILABILITY OF ABSTRACT <input checked="" type="checkbox"/> UNCLASSIFIED/UNLIMITED <input type="checkbox"/> SAME AS RPT. <input type="checkbox"/> DTIC USERS		21. ABSTRACT SECURITY CLASSIFICATION UNCLASSIFIED	
22a. NAME OF RESPONSIBLE INDIVIDUAL Raymond W. Nethers		22b. TELEPHONE (Include Area Code) (505) 844-3412	
		22c. OFFICE SYMBOL NTAO	

UNCLASSIFIED

SECURITY CLASSIFICATION OF THIS PAGE

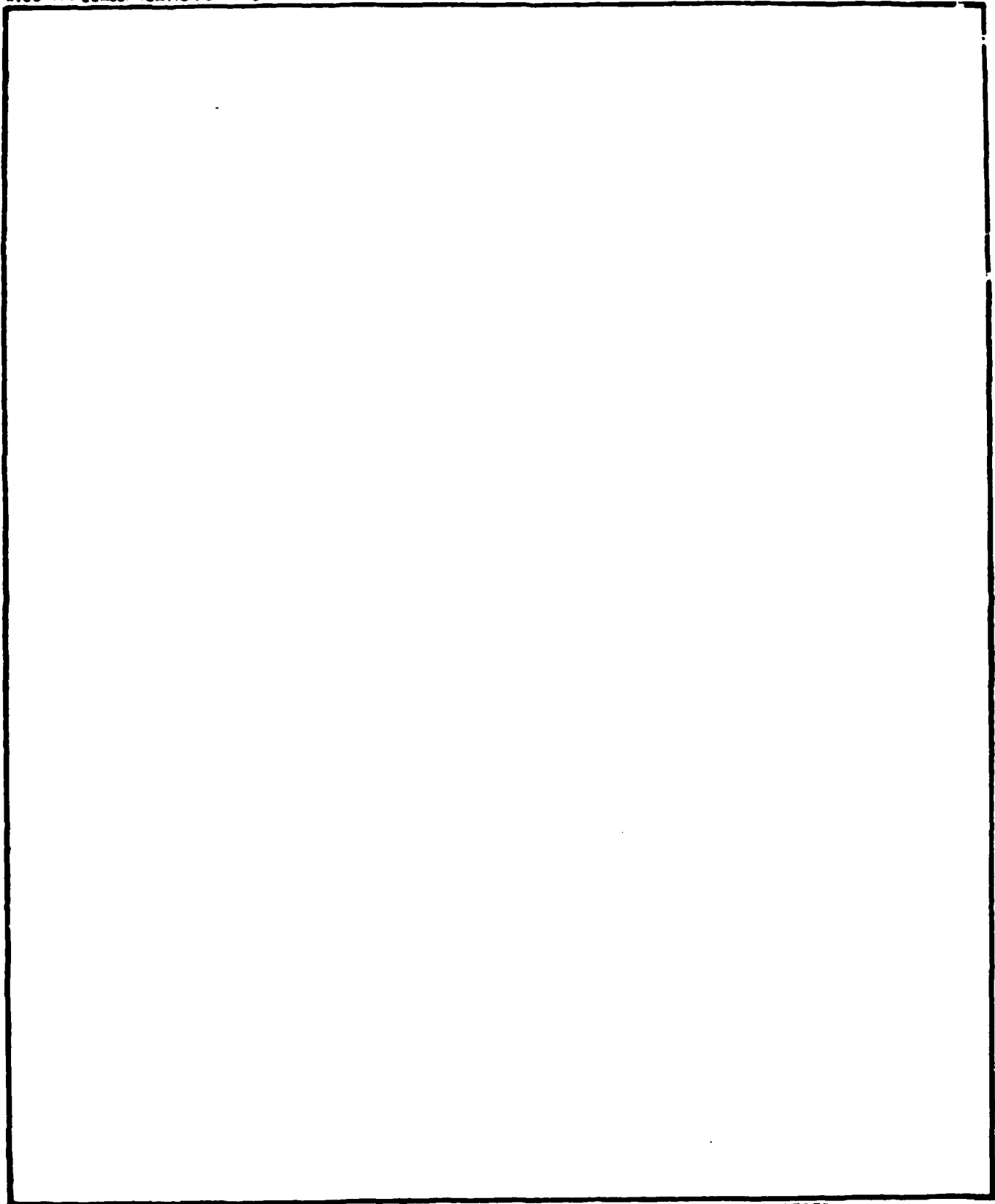

UNCLASSIFIED

SECURITY CLASSIFICATION OF THIS PAGE

INTRODUCTION

This report presents the results of tests conducted with the Ferranti impulse generator (FIG) and the mobile upper electrode (MUE) to determine if there is a cost effective method to improve the electrical insulation of a given geometry. The materials tested (Table 1) were chosen based on their availability and cost.



Accession For	
NTIS - GFA&I	<input checked="" type="checkbox"/>
DTIC TAB	<input type="checkbox"/>
Unannounced	<input type="checkbox"/>
Justification	<input type="checkbox"/>
By _____	
Distribution/	
Availability _____	
Availability _____	
Dist	
A-1	

BACKGROUND

In the past, the only way to reduce the physical size of any high voltage system was to immerse it in an insulating fluid. These fluids were either dielectric oil or an insulating gas, such as sulfur hexafluoride or freon. These fluids are very expensive and difficult to contain.

The volume and expense of fluids required to insulate most systems make it beneficial to find a lower cost insulating system. A scheme where a given gap in air would have a thin solid dielectric inserted into the geometry would be a highly cost-effective method to improve the insulating value.

TEST CONDUCT

The 20-stage FIG was configured to produce a waveform with a $1.7 \mu\text{s}$ rise time and a $37 \mu\text{s}$ decaytime. The Mobile Upper Electrode (MUE) was raised to a height of 2 m above the ground plane (Fig. 1). This was done to establish a uniform field which could be enhanced.

The field was then enhanced by erecting a 1.22×0.91 m parallel plate test electrode 1.25 m above the ground plane and centered on the MUE (Fig. 2.). This was done so that when breakdown occurred, it would be between the test electrode and the MUE.

During the first test, the FIG voltage was increased gradually until a breakdown occurred across the 0.75 m air gap. The rest of the tests were made with the insulating materials placed on the test electrode. The insulating materials overhung the test electrode by at least 0.15 m on each side to preclude the arc going around the insulant. The FIG voltage was again gradually increased until breakdown occurred. This procedure was repeated at least three times for each material tested.

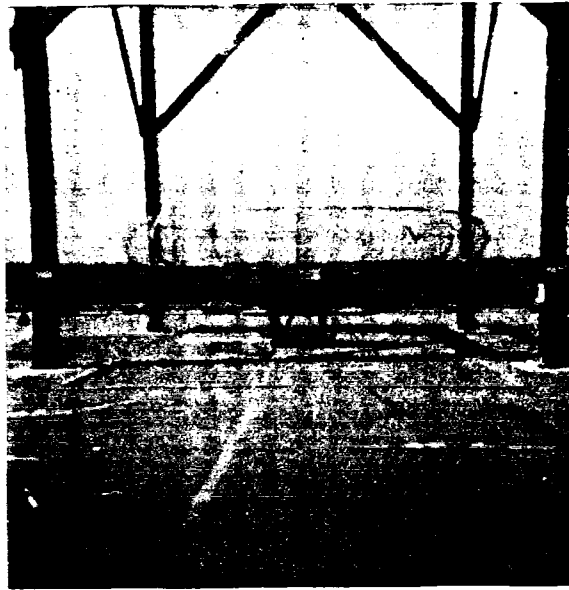

(a) Test set-up

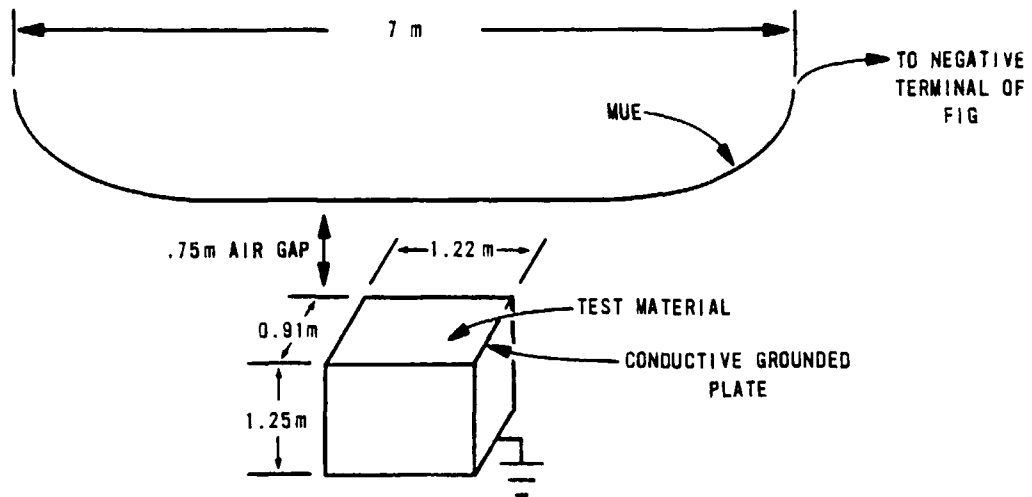

(b) Test set-up schematic

Figure 1. Test set-up.

RESULTS

As can be observed from the data in Table 1, none of the materials tested provided an appreciable improvement in insulation above ambient air except for multiple layers of mylar which gave a 44 percent increase. Some materials such as styrofoam and polypropylene sheets are actually worse than ambient air. Except for multiple mylar layers, the above materials are not recommended for high voltage insulation.

TABLE 1. List of tested materials and results.

Insulation Material	Breakdown Voltage(kV)	Effectiveness Comparison	GAP Holdoff (MV/m)
<u>Single sheets</u>			
Air Gap, no insulation	333	1.00	0.444
Plywood, 3/4 in	423	1.27	0.564
Polycarbonate, 1/8 in	417	1.25	0.556
Formica, 1/16 in	417	1.25	0.556
Styrofoam, 1 in	320	0.96	0.427
Polypropylene, 10 mil	307	0.92	0.409
Mylar, 7 mil	372	1.12	0.496
<u>Layered materials</u>			
Polycarbonate, 1/8 in, 2 sheets	432	1.30	0.576
Formica, 1/16 in, 2 sheets	449	1.35	0.599
Polypropylene, 10 mil, 3 layers	378	1.14	0.504
Mylar, 7 mil, 2 layers	480	1.44	0.640
<u>Layered dissimilar materials</u>			
Polycarbonate - Formica	385	1.15	0.512
Polycarbonate	384	1.15	0.513
Formica - Plywood - Formica	362	1.09	0.483