

2



**US Army Corps
of Engineers**

Construction Engineering
Research Laboratory

USA-CERL TECHNICAL REPORT N-88/18
July 1988
FTAT: Indoor Maintenance Platform Retrofits

AD-A198 352

Remodeling a TAC Shop for Indoor Scheduled Vehicle Maintenance

by
Gary L. Gerdes
Leslie J. Benson
Thomas B. Burns

Most Tactical Equipment Maintenance (TAC) shops at Army installations are designed with few features promoting efficient, environmentally safe scheduled maintenance of tactical vehicles. Scheduled maintenance includes changing fluids, lubrication, cleaning engines and engine compartments, and visually inspecting vehicles. To improve the efficiency of the maintenance process and ensure sound environmental practices, the U.S. Army Construction Engineering Research Laboratory (USA-CERL) has developed the *Scheduled Maintenance Facility (SMF) concept* for use in both new construction and retrofitting.

The SMF concept has been applied to new construction in several cases and has proven successful. To show the feasibility of using the concept in retrofit application, USA-CERL has remodeled a TAC shop at Fort Carson, CO, as part of the Facilities Technology Applications Test (FTAT) program. The new equipment and features added to the TAC shop have provided the same features that would have been possible with new construction.

This report describes the retrofit design and includes the lessons learned from design phase through initial use of the facility. Site drawings and some details from the initial design also are included.

Approved for public release; distribution is unlimited.

DTIC
ELECTE
S AUG 3 1 1988 D
H

DISCLAIMER NOTICE

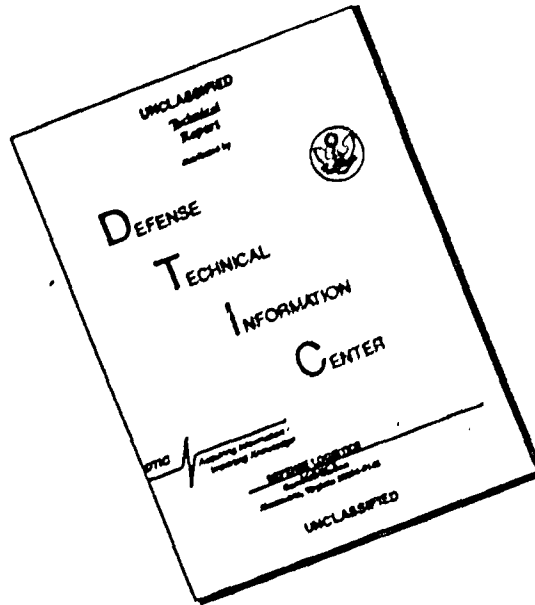

THIS DOCUMENT IS BEST QUALITY AVAILABLE. THE COPY FURNISHED TO DTIC CONTAINED A SIGNIFICANT NUMBER OF PAGES WHICH DO NOT REPRODUCE LEGIBLY.

The contents of this report are not to be used for advertising, publication, or promotional purposes. Citation of trade names does not constitute an official indorsement or approval of the use of such commercial products. The findings of this report are not to be construed as an official Department of the Army position, unless so designated by other authorized documents.

***DESTROY THIS REPORT WHEN IT IS NO LONGER NEEDED
DO NOT RETURN IT TO THE ORIGINATOR***

UNCLASSIFIED
SECURITY CLASSIFICATION OF THIS PAGE

REPORT DOCUMENTATION PAGE

Form Approved
OMB No 0704 0188
Exp Date Jun 30 1986

1a REPORT SECURITY CLASSIFICATION UNCLASSIFIED		1b RESTRICTIVE MARKINGS	
2a SECURITY CLASSIFICATION AUTHORITY		3 DISTRIBUTION AVAILABILITY OF REPORT Approved for public release; distribution is unlimited.	
2b DECLASSIFICATION/DOWNGRADING SCHEDULE		5 MONITORING ORGANIZATION REPORT NUMBER(S)	
4 PERFORMING ORGANIZATION REPORT NUMBER(S) USA-CERL TR N-88/18		7a NAME OF MONITORING ORGANIZATION	
6a NAME OF PERFORMING ORGANIZATION U.S. Army Construction Engr Research Laboratory	6b OFFICE SYMBOL (If applicable) CECER-EN	7b ADDRESS (City, State, and ZIP Code)	
6c ADDRESS (City, State, and ZIP Code) P.O. Box 4005 Champaign, IL 61820-1305		9 PROCUREMENT INSTRUMENT IDENTIFICATION NUMBER FTAT Work Unit, "Indoor Maintenance Platform Retrofits" (FTAT-EN-FP7)	
8a NAME OF FUNDING SPONSORING ORGANIZATION USAHSC	8b OFFICE SYMBOL (If applicable) CEHSC-FU-S	10 SOURCE OF FUNDING NUMBERS	
8c ADDRESS (City, State, and ZIP Code) Fort Belvoir, VA 22060-5580		PROGRAM ELEMENT NO	PROJECT NO
11 TITLE (Include Security Classification) Remodeling a TAC Shop for Indoor Scheduled Vehicle Maintenance (Unclassified)		TASK NO	WORK UNIT ACCESSION NO
12 PERSONAL AUTHOR(S) Gerdes, Gary L., Benson, Leslie J., Burns, Thomas B.			
13a TYPE OF REPORT Final	13b TIME COVERED FROM _____ TO _____	14 DATE OF REPORT (Year, Month, Day) 1988, July	15 PAGE COUNT 27
16 SUPPLEMENTARY NOTATION Copies are available from the National Technical Information Service Springfield, VA 22161			
17 COSATI CODES		18 SUBJECT TERMS (Continue on reverse if necessary and identify by block number)	
FIELD	GROUP	Scheduled Maintenance Facility	
15	05	Tactical Equipment Maintenance	
		military vehicles maintenance	
19 ABSTRACT (Continue on reverse if necessary and identify by block number)			
<p>Most Tactical Equipment Maintenance (TAC) shops at Army installations are designed with few features promoting efficient, environmentally safe scheduled maintenance of tactical vehicles. Scheduled maintenance includes changing fluids, lubrication, cleaning engines and engine compartments, and visually inspecting vehicles. To improve the efficiency of the maintenance process and ensure sound environmental practices, the U.S. Army Construction Engineering Research Laboratory (USA-CERL) has developed the Scheduled Maintenance Facility (SMF) concept for use in both new construction and retrofitting.</p> <p>The SMF concept has been applied to new construction in several cases and has proven successful. To show the feasibility of using the concept in retrofit applications,</p>			
20 DISTRIBUTION AVAILABILITY OF ABSTRACT <input type="checkbox"/> UNCLASSIFIED UNLIMITED <input checked="" type="checkbox"/> SAME AS RPT <input type="checkbox"/> DTIC USERS		21 ABSTRACT SECURITY CLASSIFICATION UNCLASSIFIED	
22a NAME OF RESPONSIBLE INDIVIDUAL DANA FINNEY		22b TELEPHONE (Include Area Code) (217)352-6511, ext. 389	22c OFFICE SYMBOL CECER-IMT

(Cont'd)

UNCLASSIFIED

BLOCK 19. (Cont'd)

- ▶ USA-CERL has remodeled a TAC shop at Fort Carson, CO, as part of the Facilities Technology Applications Test (FTAT) program. The new equipment and features added to the TAC shop have provided the same capabilities that would have been possible with new construction.

This report describes the retrofit design and includes the lessons learned from design phase through initial use of the facility. Site drawings and some details from the initial design also are included.

Regards: Military Services, Inc.

FOREWORD

This work was conducted for the U.S. Army Engineering and Housing Support Center (USAEHSC), under the Facilities Technology Applications Test (FTAT) program, Work Unit FTAT-EN-FP7, "Indoor Maintenance Platform Retrofits." The USAEHSC Technical Monitor was Thomas Wash, CEHSC-FU-S.

The study was conducted by the Environmental Division (EN), U.S. Army Construction Engineering Research Laboratory (USA-CERL). Dr. R. K. Jain is Chief, EN. Thomas Burns is with Burns, Clancy, and Associates, Champaign, IL. The technical editor was Dana Finney, USA-CERL Information Management Office.

Valuable contributions were made during this study by individuals at the Fort Carson, CO, test site: Nelson Kelm, Directorate of Engineering and Housing, and MAJ Kent, Executive Officer of the 1-29 Field Artillery Battalion. The Project Management Section and Construction Division at the Omaha District Corps of Engineers handled all design review, construction contracting, and monitoring associated with this project.

COL N. C. Hintz is Commander and Director of USA-CERL, and Dr. L. R. Shaffer is Technical Director.



Accession For	
NTIS GRA&I	<input checked="" type="checkbox"/>
DTIC TAB	<input type="checkbox"/>
Unannounced	<input type="checkbox"/>
Justification _____	
By _____	
Distribution/	

CONTENTS

	Page
DD FORM 1473	1
FOREWORD	3
1 INTRODUCTION	5
Background	
Objective	
Approach	
Mode of Technology Transfer	
2 RETROFIT DESIGN	7
Existing Building	
Limitations	
Retrofit Improvements	
Support and Equipment Area	
Vehicle Maintenance Pits	
High-Pressure, Hot-Water Wash Equipment	
Utilities and Installation	
Overhead Lift	
Grease and Oil Dispensing System	
Waste Oil Collection	
Antifreeze Collection	
Wastewater Collection System	
Wastewater Pretreatment System	
Waste Oil and Antifreeze Storage Facilities	
Electrical and Compressed Air Outlets	
Lessons Learned	
Costs Analysis	
3 CONCLUSIONS AND RECOMMENDATIONS	24
METRIC CONVERSION TABLE	24
DISTRIBUTION	

REMODELING A TAC SHOP FOR INDOOR SCHEDULED VEHICLE MAINTENANCE

1 INTRODUCTION

Background

Army tactical units perform scheduled maintenance of vehicles at their own motor pools or Tactical Equipment Maintenance (TAC) shops. Most Army TAC shops were designed more than 10 years ago and have very few features that allow efficient scheduled maintenance. In the past, these activities were generally performed at outdoor washracks for lack of better facilities. Some examples of scheduled maintenance tasks are cleaning engines and compartments, changing lubricating and other fluids, disposing of used fluids, and inspecting vehicles for parts requiring further maintenance or repair.

The U.S. Army Construction Engineering Research Laboratory (USA-CERL) has developed the Scheduled Maintenance Facility (SMF) concept to improve efficiency and environmental safety in new and retrofit construction.¹ The SMF concept was originally intended to solve environmental problems associated with scheduled maintenance of tactical ground vehicles. However, it became apparent while USA-CERL was studying these problems that the overall operation needed to be changed to make it both environmentally sound and more efficient. The USA-CERL concept that evolved from this study includes the following maintenance facility equipment features:

1. High-pressure, low-volume, hot-water washers are used by troops instead of solvents and detergents to clean parts, engine packs, and engine compartments.
2. A maintenance pit is provided in the floor of the bay for easy, safe access to vehicle undercarriages.
3. X-Y directional cranes are installed to remove engine packs and lift other bulky items.
4. Movable drains are located in the maintenance pit for collecting used oil and antifreeze; the plumbing provides direct discharge to storage tanks.
5. Equipment is provided for bulk storage and dispensing of motor oil, transmission oil, lubricating grease, and antifreeze; fluid and compressed-air hoses are located in and above the maintenance pit.
6. Equipment is provided to collect and pretreat wastewater from the hot-water washing, with discharge to the sanitary sewer.
7. Storage is provided for used oil and antifreeze.

¹Engineer Technical Letter (ETL), *Recommended Design Guidance for Cost-Effective Vehicle Maintenance Cleaning and Servicing*, Draft Headquarters, U.S. Army Corps of

The SMF concept has been incorporated into several designs for new construction. To show that the concept is equally feasible in retrofit applications, USA-CERL has demonstrated SMF in remodeling an existing TAC shop at Fort Carson, CO. The demonstration was part of the Facilities Technology Applications Test (FTAT) program.

Retrofitting can be an important alternative to new construction in planning for SMFs. A retrofit would be the logical choice in cases for which:

- It is less expensive than new construction
- There are space constraints at installations that need SMFs
- Funding is available for renovation/remodeling but not for new construction.

Objective

The primary objective of this project was to determine if a portion of an existing TAC shop could be retrofitted to become a functional SMF. Further, the study was to determine if this retrofit would be cost-effective in providing an environmentally safe, efficient facility.

Approach

Building 1692, a TAC shop at Fort Carson, CO, was chosen as the test site. A design was developed that would incorporate all SMF features mentioned above through a renovation of that building. The Omaha District Corps of Engineers then reviewed the design and prepared it for bid solicitation. The District awarded the construction contract and managed the construction project.

USA-CERL monitored the project to determine if the design could be improved in any way. Upon completion, the facility was turned over to the users (the 1-29 Field Artillery Battalion). The users' evaluation was documented, performance of the pollution control features was determined, and a cost analysis was conducted.

Mode of Technology Transfer

The tests at building 1692 effectively transferred the SMF retrofit technology to Fort Carson and the Omaha District. The Fort Carson project could potentially serve as a prototype for future retrofits at other U.S. Army Forces Command (FORSCOM) installations. USA-CERL is preparing a draft Engineer Technical Letter (ETL) to summarize the information in this report. Full-scale design drawings for this project are available from the USA-CERL Environmental Division, telephone commercial (217) 373-6734 or toll-free 1-800-USA-CERL (outside Illinois); 1-800-252-7122 (inside the state).

2 RETROFIT DESIGN

Existing Building

The vehicle maintenance facility chosen as the test site at Fort Carson (building 1692) is typical of a design developed for troops to service and maintain numerous different types of tactical vehicles associated with an Army installation. Configurations and construction materials are typical; orientation is the variable element. Refer to the site location plan (Figure 1) for building orientation and site layout. The floor plan prior to remodeling (Figure 2) shows noteworthy existing conditions within the two bays comprising the project area. The facility has reinforced cast-in-place concrete floor slabs, isolated footings, and grade beams at the perimeter for the foundation system. The floor slab is a 9-in.* reinforced cast-in-place concrete slab on grade. At the exterior walls, there is a 14-in. double-wythe concrete masonry unit wall that extends 3 ft 10 in. above the finished floor. From this point to the eave line, the wall material is insulated metal siding. The openings that penetrate the side walls are 18 ft wide by 16 ft high overhead metal doors for vehicle access into the maintenance service bays. The end wall of the outside bay in the project area is a 14-in. double-wythe concrete masonry unit wall that extends above the roof line. The roof is constructed of metal roof deck, 1-1/2-in. rigid construction and a built-up roof.

The structural system is a steel frame. Columns are steel wide-flange shapes; channel shapes are used for girts to attach the siding. The roof framing system is constructed of shop-fabricated steel trusses which are end frames into the flanges of the columns and span perpendicular to the side walls. Steel open-web joists are used as purlins to support the metal roof deck.

Limitations

There were no critical elements in the structural and architectural systems of the existing building that would have prohibited renovation. The existing facility was not as wide as new facilities currently being constructed, which limited the length of the maintenance pits. Although a shorter pit did not reduce the number or types of vehicles currently serviced in the bay, it did make maintenance activities somewhat cramped. The largest obstacle to overcome was the existing height limitations of the maintenance bays, such as overhead doors and lights, as they related to the operation of a gantry crane. Figure 3 shows details of these height limitations.

Retrofit Improvements

All SMF concept features were included in the retrofit design. Following are detailed descriptions of these and other design features.

Support and Equipment Areas

Interviews with motor pool personnel at the beginning of the study influenced the allocation and orientation of space within the support and equipment areas and also impacted the usage of the maintenance area. A dedicated, secure area for storing

maintenance tools and other items had to be convenient and readily accessible. The existing fire exit at the end wall of the building had to be maintained with a clear means of egress to the exterior.

The motor pool personnel requested an area for workbenches on which to lay carburetors and other small items so that they could work on them. The recessed area shown in Figure 4 was provided for storing workbenches and small equipment (e.g., battery chargers) so as not to encroach on the maintenance area.

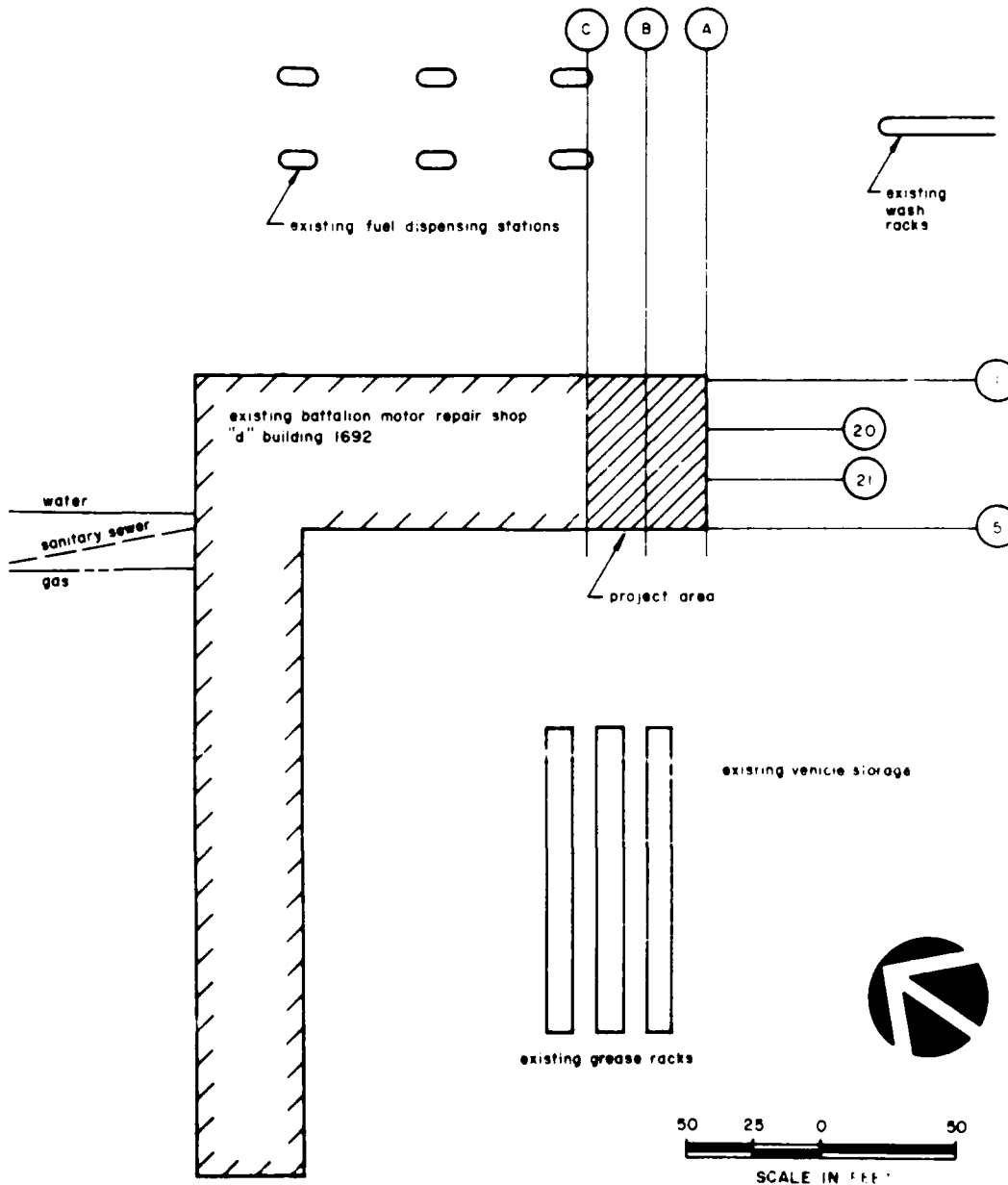

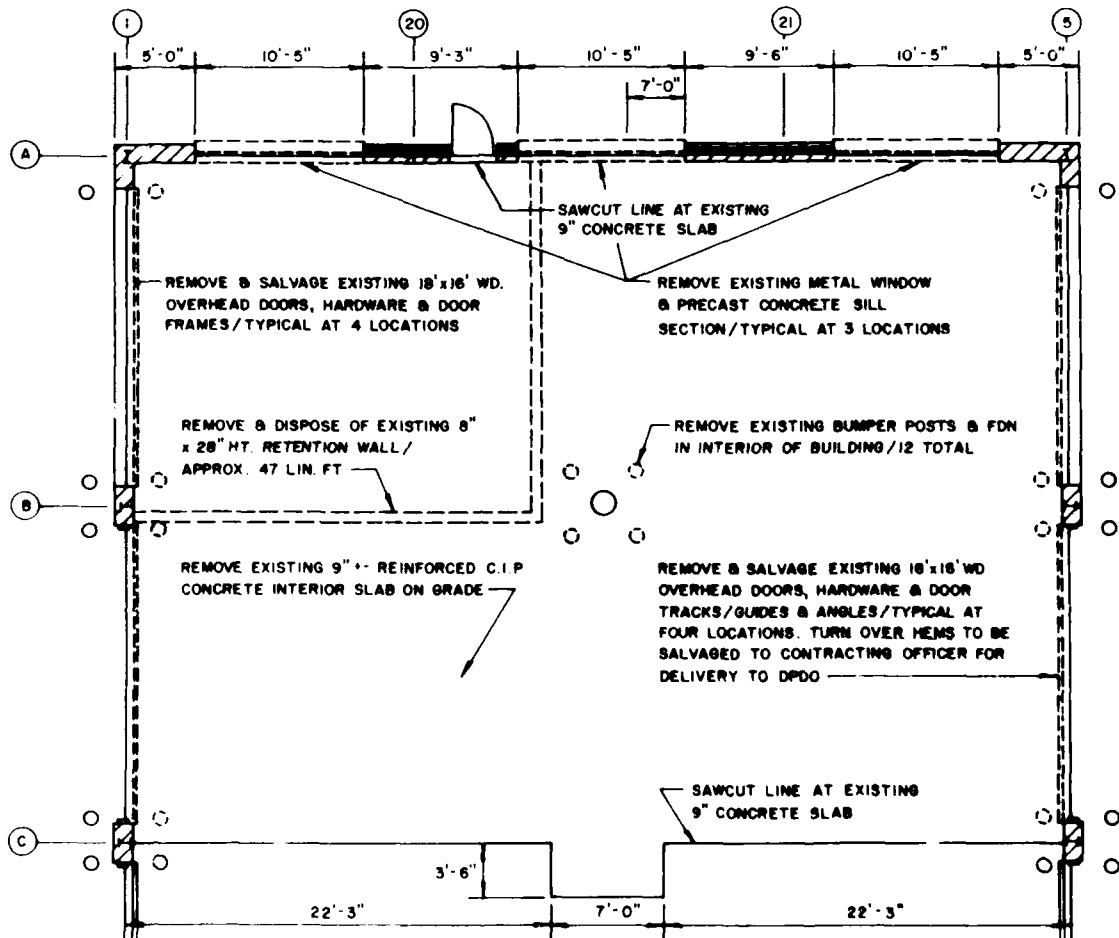

Figure 2. TAC shop floor plan prior to remodeling.

A separate enclosed area for the high-pressure, hot-water washer had to be provided to prevent any misuse or tampering with the equipment. It was also required by the fire safety code since the hot-water washer is gas-fired.

A receiving and storage area was required for petroleum, oil, and lubricant (POL) within the TAC shop for distributing POL to the maintenance area by a bulk dispensing system. This area was located so that POL could be delivered through a separate access to avoid disruptions to service activities in the maintenance area. The fire code requires that a POL storage area have a 2-hr fire-rated ceiling for protecting the rest of the building. A cast-in-place reinforced concrete ceiling met the required fire rating.

It was noted that, if the concrete ceiling were extended over the support and

matched a second level and there would have been adequate height for a second floor (see Figure 5). Due to the funding limitations of this project, the second story was not finished. However, the current facility users have expressed a need to develop that space for their use.

A new air compressor provides the air for pneumatic pumps that distribute lubricants to the dispensing stations. The electrical/air compressor area is adjacent to the POL storage area and was situated to protect the existing electrical panels and controls located on the end wall of the electrical room shown in Figure 4. It would have been expensive to relocate these existing panels and controls.

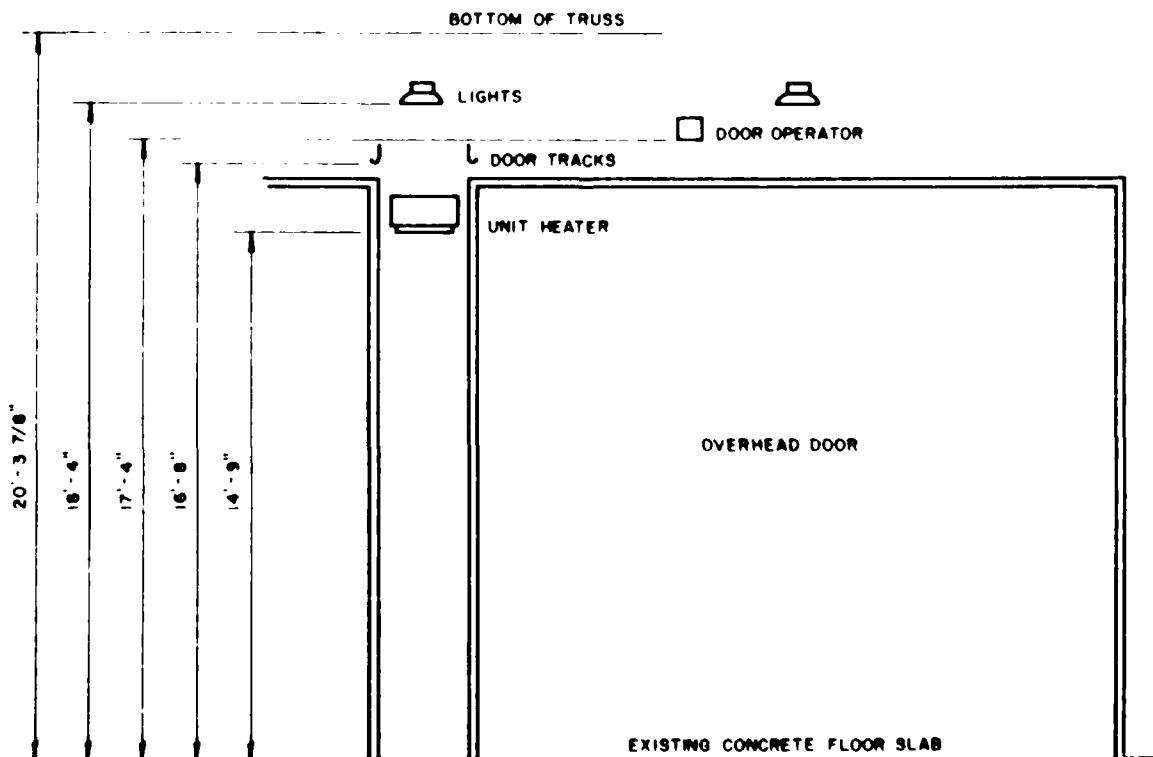

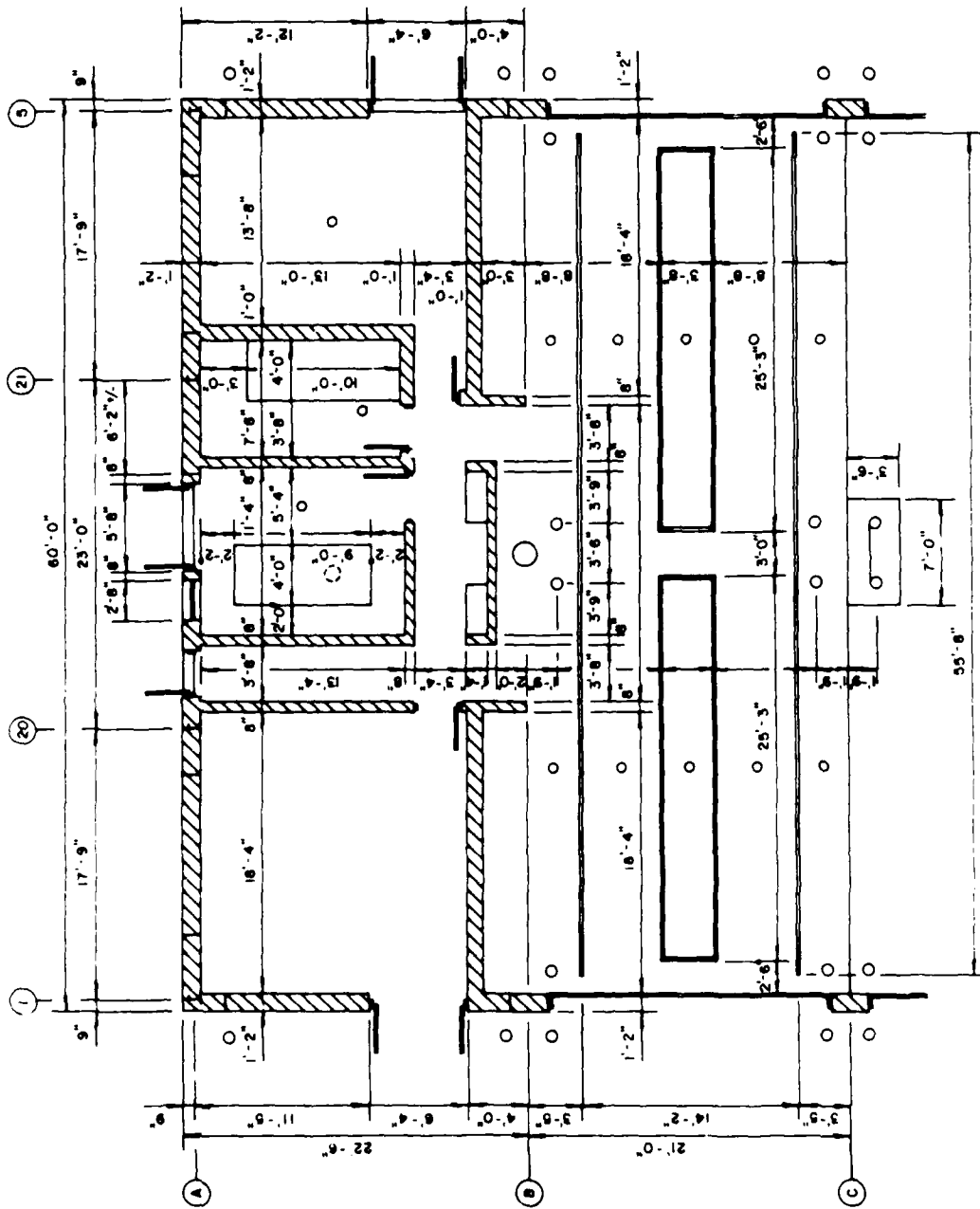

Figure 4. Retrofit floor plan.

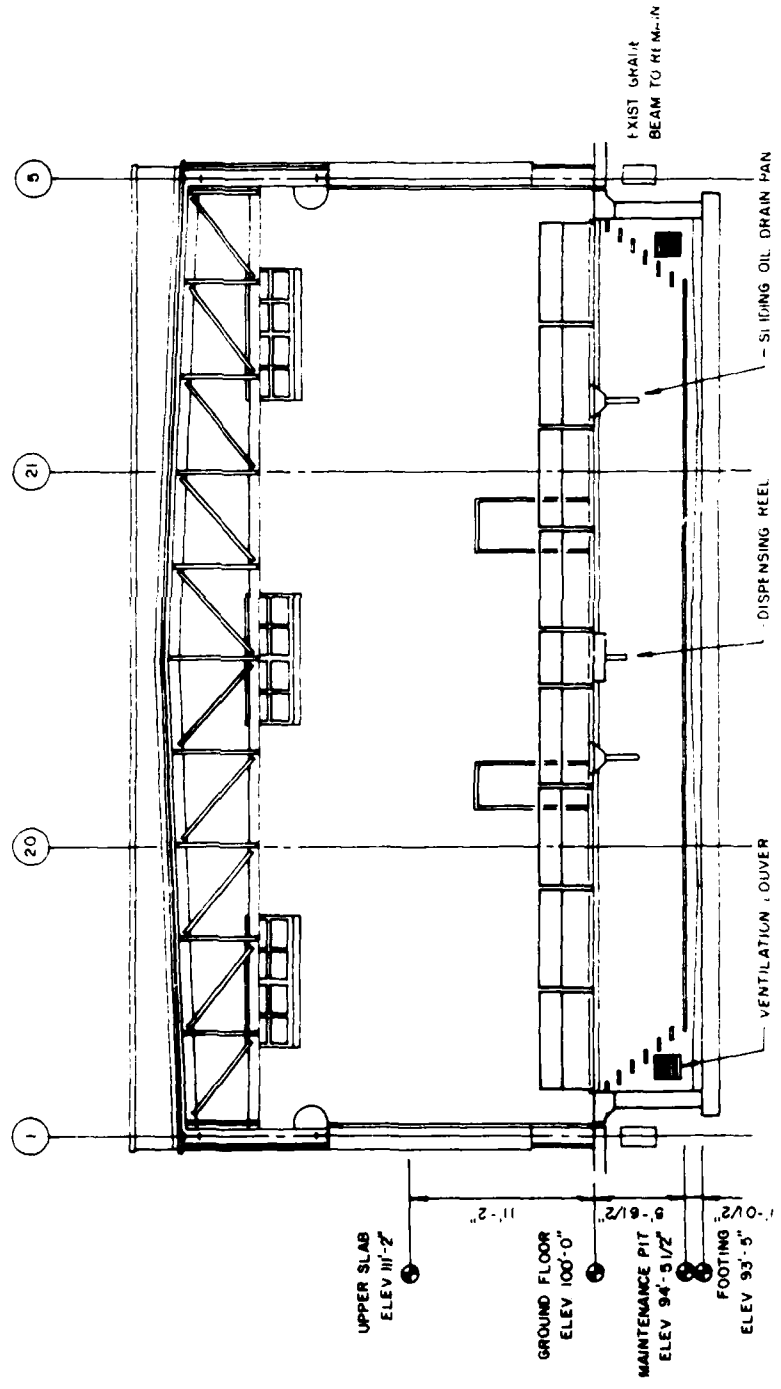

Figure 5. Section where retrofit improvements were incorporated.

Vehicle Maintenance Pits

Due to restrictions in the space allotment, only one maintenance pit was constructed. It extends the entire length of the bay, except for a minimum area at each end and at the center to allow for troop movement around the vehicles being serviced. The pit is divided into two sections or pit areas, each approximately 25 ft 3 in. long. Stairs are located at each end of the pit, which further reduces the usable length of the maintenance pit by approximately 40 in. (A ladder for access into the pit had been determined to be dangerous and unsuitable.) A working length of approximately 22 ft is adequate for servicing many of the vehicles currently in the unit. Under these conditions, two vehicles can be serviced at once. Larger vehicles, such as the 5- and 8-ton cargo trucks and the M-1 tank, can be serviced but will overlap into the adjacent maintenance pit section.

The maintenance pit is centered in the bay. The idea of offsetting the pit to achieve a larger working area on one side was discussed and studied in detail. It was concluded that the bays and doors were too narrow to gain an advantage by offsetting the pit from the centerline of the bay and door.

The width of the pit, 44 in., was determined from the wheel base of the smallest vehicle currently being serviced by the unit. The perimeter of the pit was curbed as is required. A cast-in-place concrete curb section was not acceptable due to the abuse that tracked vehicles can inflict. Designers for recently constructed maintenance facilities have used a steel tube as a curb for the maintenance pit. In the Fort Carson design, a steel angle section was used instead of a tube section because it allowed the pit to be 4 to 6 in. wider, which improves worker mobility within the maintenance pit. This steel section is galvanized to prevent deterioration due to the washing functions and corrosive materials used in the maintenance area.

It is desirable to make the pit as deep as possible to increase the working height and comfort for personnel servicing the vehicle undercarriages. The 4 ft 9 in. depth (from finished floor to top of grating) is adequate for servicing the larger vehicles, but is tight when servicing a vehicle with low ground clearance such as a jeep. This depth was calculated by conforming to the suggested rise/tread (run) ratio for the stair as per U.S. Occupational Safety and Health Administration (OSHA) requirements. Designers tried to achieve the maximum rise in the minimum run to allocate more to the net length inside the pit.

A removable handrail is installed around the perimeter of the pit to prevent personnel from falling into the pit when maintenance is not being performed on a vehicle. For proper use, the handrail had to be convenient to remove and replace (i.e., it could not encumber personnel to the point of being awkward to use). The handrail specified is fabricated in sections, removable (by means of a sleeve welded to the curb) and manageable by one person.

The floor of the pit needed a bar grating so that water and debris from the maintenance process can fall to the concrete floor of the pit and be drained away. This grating keeps the pit floor walking surface clean and free of debris, and avoids the problems of working in standing water. It was concluded that fiberglass grating should be used instead of metal. Fiberglass grating is lighter in weight, has excellent resistance to corrosive action that can occur with metal grating, is nonconductive and slip-resistant, and is Class I fire-resistant and self-extinguishing. However, the grating chosen was not strong enough to withstand normal abuse from the maintenance operations. It is recommended that steel grating with a nonslip surface be used in future projects.

The grating was made in easy-to-remove sections for access to the drains and the bottom of the maintenance pit. The stair treads were also made of the fiberglass grating material, and also should have been steel. A continuous galvanized bar along the length of the pit provides the support for the floor grating as shown in Figure 6. This bar support has less surface area where water and debris can accumulate than would an angle or formed ledge support.

A formed, recessed tool shelf was placed in the maintenance pit. This shelf (Figure 6) provides a convenient area to store tools and miscellaneous parts, thereby preventing personnel from laying items on the floor of the maintenance pit and creating a potential hazard. One problem has arisen with the shelf: it does not drain. Future designs should include a provision to prevent water from collecting on the shelf.

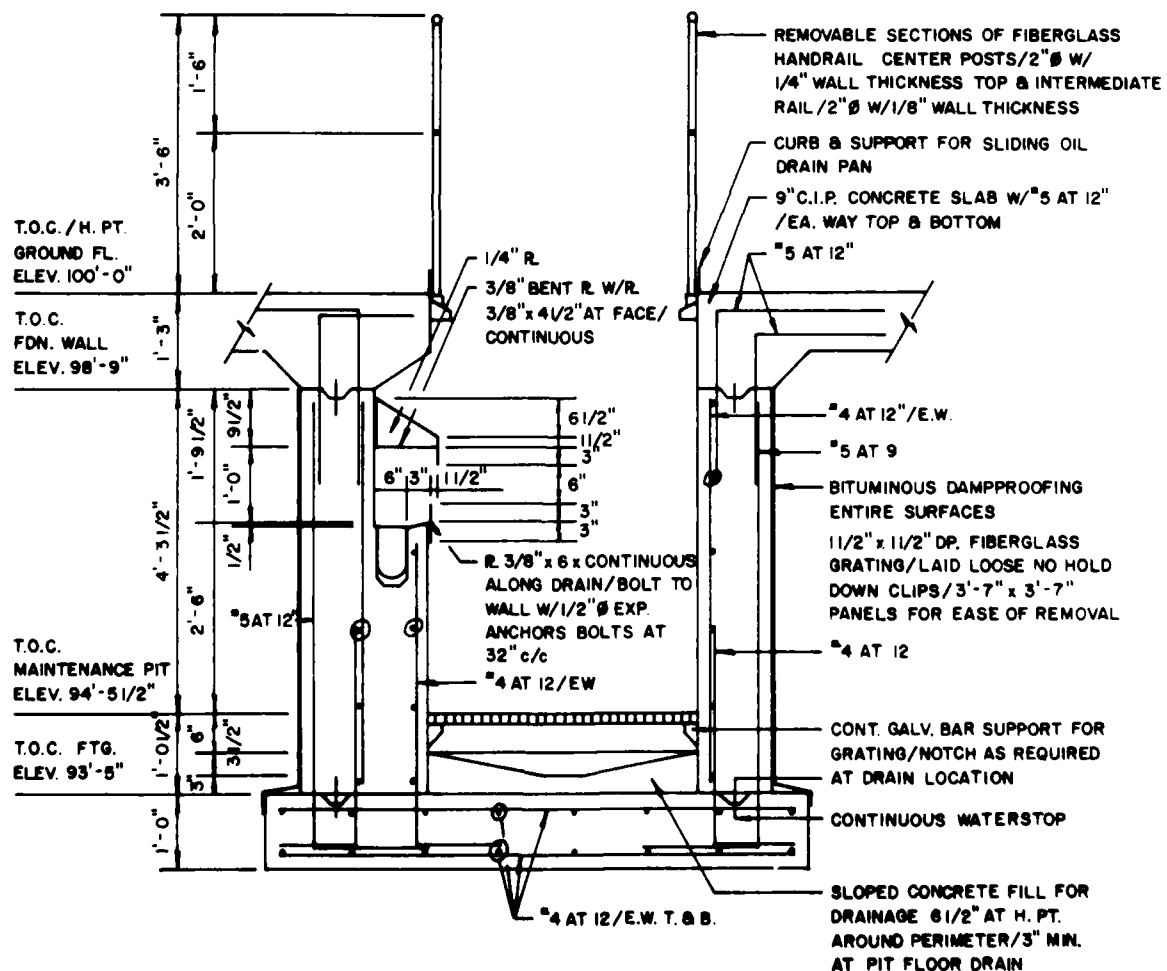

Figure 6. Section of maintenance pit.

Ventilation of the maintenance pit was incorporated into the design to remove carbon monoxide fumes that can accumulate from vehicle exhaust. A positive ventilation system is recommended with an underground duct to the exterior. A ventilating duct was installed in the side wall at each end of the maintenance pit and tied to the existing ventilating system.

High-Pressure, Hot-Water Wash Equipment

In accordance with a draft ETL² maintenance cleaning is done at this facility using high-pressure, low-volume, hot-water wash equipment. The pressure washer provides 800 psi hot water at 5 gpm to each of two wash stations.

Two remote wash stations are located in the center of the maintenance bay--one on each side of the maintenance pit--as shown in Figure 4. Each remote wash station is equipped with a wash wand and hose. The hoses from the remote wash stations are long enough to reach the far end of the maintenance pit so that a section or part of a vehicle can be cleaned regardless of its length or location in the bay. The hoses are fed from a rewinding dispensing reel so the wash wands can be conveniently returned to the remote stations when not in use. The wash stations were located outside the area of crane travel. Extra care must be taken during the infrequent times the crane is moved to prevent damage to the hoses.

The pressure wash equipment is housed in a separate room in the support and equipment area. Only authorized persons can start and adjust the wash equipment to prevent continuous tinkering by other motor pool personnel. The floor of the wash equipment room drains to the wastewater collection and pretreatment system. The room is ventilated in accordance with the wash equipment manufacturer's recommendations.

Utilities and Installation

Specific requirements and details of the equipment installation were provided by the manufacturer or the supplier. The existing TAC building had all the required utility systems readily available to support the wash equipment, but this may not be true at other installations. Adequate electrical power, natural gas, and potable water meeting or exceeding the manufacturer's recommended pressure and flow rates are necessary for proper operation of the wash equipment, water softeners, pressure regulators, and other components.

Overhead Lift

Criteria. An overhead lift with a capability of 7-1/2 tons is desired to facilitate maintenance operations. The crane must be able to travel in the transverse and longitudinal (X-Y) directions within the bay. The hook height must be a minimum of 14 ft off the finished floor to give the clearance required for removing an engine pack and other miscellaneous tasks performed during maintenance.

Evaluation of Alternative Cranes. The existing frame system was not strong enough to support a bridge crane. Moreover, it was determined to be too expensive to install new columns and framing to support such a crane.

²Recommended Design Guidance for Cost-Effective Vehicle Maintenance Cleaning and Servicing.

A jib crane is a hoist beam cantilevered from a center-mounted mast that rotates about a center vertical axis. Use of a jib crane was evaluated in great detail. The application of a jib appeared interesting in that, not only could it service the two maintenance pits, but if the decision were made at a future date to add two extra maintenance pits adjacent to the proposed bay of the retrofit, the jib crane could be used to service all four of these pits.

The overwhelming problem with the jib crane is that the required depth of the hoist beam becomes too large due to the cantilevered span and the lifting capacity required. Because of the additional depth of the beam and the minimum required clearance of 14 ft, installation of a jib hoist was prohibited due to height limitations of the existing structure.

A portable gantry crane also was rejected based on several important issues. First, the minimum height clearance of 14 ft could not be achieved with a hoist of this type. The maximum height that could be obtained was 12 ft 6 in., which is too low to provide the desired services. In addition, the cross bracing that stiffens the lateral resistance of the hoist beam in relation to the frame would drastically reduce lateral movement of the chain hoist. More importantly, however, is that the manufacturers contacted were definitely opposed to the use of a portable gantry crane because of its lack of stability under the required hoist loading requirements of 7-1/2 tons. Even at a 12 ft 6 in. height, the portable gantry crane would be top-heavy and tend to sway.

Recommended Crane. To fulfill the minimum requirements and provide the greatest degree of flexibility at the lowest cost, a double-leg motorized gantry crane was used. To achieve the 14 ft minimum clearance for the hook height, the two existing doors of this bay had to be removed and replaced with taller doors. In addition, the center row of lights was raised so that it would not obstruct the crane's path of travel.

The double-legged gantry crane is motor-driven and travels in a longitudinal direction on crane rails located at each side of the maintenance pit as shown in the floor plan (Figure 4). The rails are recessed into the floor slab. While the recessed rails are much safer than raised rails, they have problems; for example, dirt, grit, scum, and water tend to collect in the recession. Future projects should provide drains in these recesses for easy cleanout.

Grease and Oil Dispensing System

Grease and oil lubricants are distributed to the maintenance area by a pressurized dispensing system. An air compressor drives the air pumps necessary to transport lubricants to the dispensing stations. As stated earlier, the bulk storage area is located in a separate enclosure consisting of 2-hr fire-rated construction.

Motor pool personnel had indicated that three items are required in the pit for the maintenance procedures performed under the vehicle: bearing grease, 90-weight oil, and compressed air. These items are distributed via hoses that are on retractable reels. The dispensing station is located at the center of the bay between the maintenance pit sections, under the crossover area (Figure 5). This location gives personnel in each maintenance pit section access to the dispensing system.

A maintenance station at floor level is located at the center of the bay opposite the wash equipment area. The hoses supplying lubricants and antifreeze are accessible at this station. Compressed-air hose reels are located next to each of the high-pressure,

Waste Oil Collection

Each maintenance pit is equipped with devices to collect used oil drained from the vehicles. To accommodate the different vehicles and their orientation when positioned over the maintenance pit, a sliding oil drain pan was installed (Figure 7). This pan can be positioned at any location in the longitudinal direction of the maintenance pit. A hinged cover was incorporated to keep out the overspray from the high-pressure, hot-water wash equipment and prevent contamination of the used oil.

The slide supports for the oil pan are modified round bars incorporated into the curb section as shown in Figure 7. Advantages of this configuration are that (1) the rounded surface eliminates a ledge which would allow water and debris to accumulate and (2) it does not have to be anchored on the face of the maintenance pit wall.

An enclosed trough was formed in the concrete wall for collecting the used oil. The trough is connected by a drain line to a waste oil storage tank located outside the building. However, during construction the contractor stated that it was difficult and expensive to form this trough. It is recommended that the trough be made of steel and mounted to the side of the maintenance pit.

Antifreeze Collection

The used antifreeze collection system is not as elaborate as the used oil collection system because the amount of liquid collected and the frequency of this service are significantly less than for used oil. Tracked vehicles are air-cooled and thus did not constrain the placement of the antifreeze collection system. The space requirements for servicing wheeled vehicles are substantially smaller, so antifreeze collection could be reduced to a more localized area in the pit. An articulated funnel with a section of flexible rubber drain hose met the requirement (Figure 8). There are two collection areas to allow some flexibility for locating vehicles to be serviced. The drain line penetrates the wall of the pit and travels to the used-antifreeze storage tank located outside the building.

Wastewater Collection System

Results of previous USA-CERL³ research showed that, when maintenance/parts cleaning are performed with high-pressure, low-volume, hot-water wash equipment, the wastewater can be easily pretreated to remove suspended solids and free oils prior to discharge to the sanitary sewer system. To provide this feature at Fort Carson, wastewater from the entire maintenance bay floor is collected in floor drains and flows to a pretreatment structure, as shown in Figure 4. Wastewater that falls into the maintenance pit collects in two drains with sediment buckets, as shown in Figure 8, and flows by gravity to the pretreatment area.

A J-trap was installed under the maintenance pit drain. However, because large amounts of oily sludge are cleaned from engine compartments, this trap now becomes plugged and blocks drainage. It is recommended that no trap or other flow interruption be placed after the pit drain in future designs.

³R. Fileccia, et al., *Pretreatment of Waste Discharges From Improved Army Tactical Equipment Maintenance Facilities*, Technical Report N-107/ADA105081 (U.S. Army Construction Engineering Research Laboratory, August 1981).

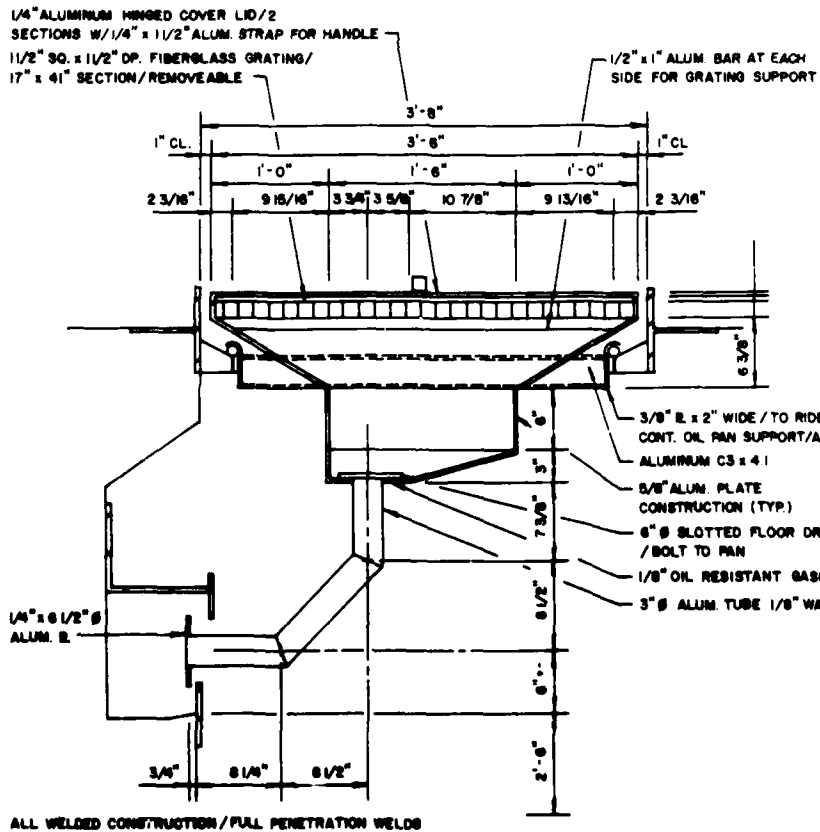
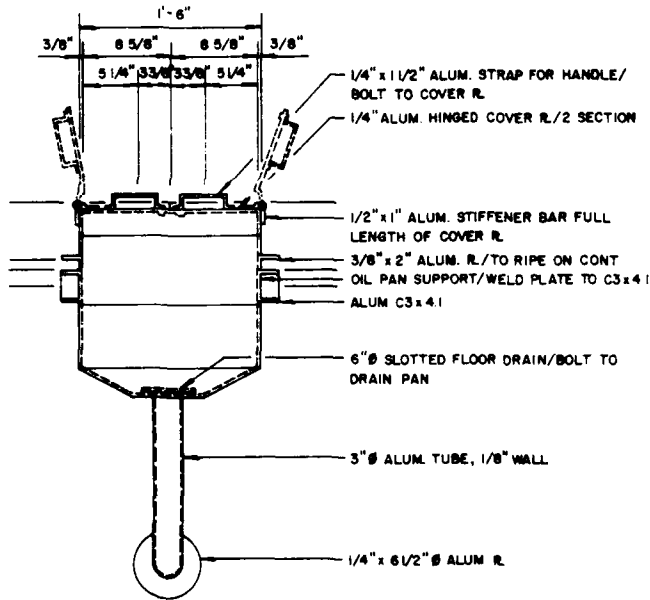

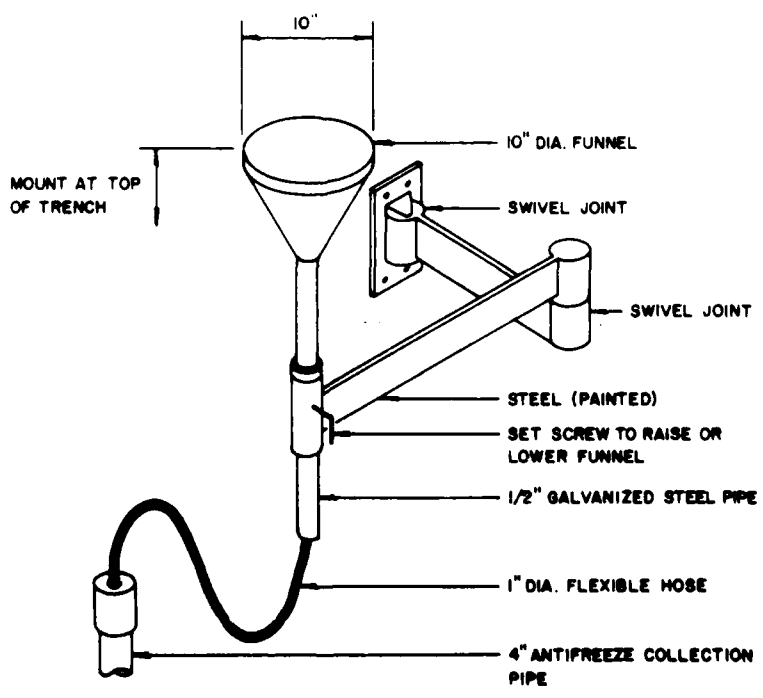
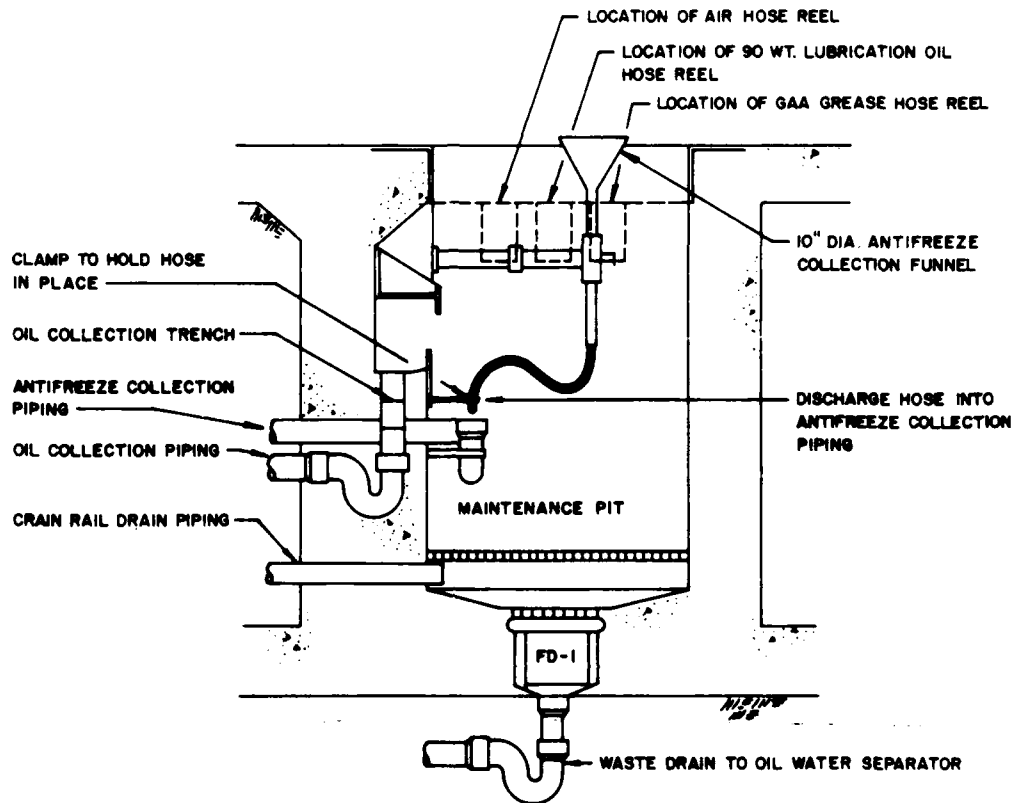

The floor of the wash equipment room in the support and equipment area drains to the pretreatment system because of backflushing and maintenance of the hot-water wash equipment. Since leakage and POL spills are possible, the floor of the POL storage area is also drained to the pretreatment system. Spills may be washed down the drain of that room but detergents and degreasers should not be used since they will interfere with pretreatment system effectiveness.

Wastewater Pretreatment System

Wastewater discharges from maintenance and parts cleaning areas are processed by simple gravitational techniques; the pretreated effluent is released to the sanitary sewer system. The pretreatment system for this facility is a parallel plate pack oil and water separator (Figure 9). This pretreatment system is located adjacent to the maintenance building. The system is located at a deep point since the oily water from cleaning operations must flow by gravity to the separator; thus, it must be located below the bottom of the maintenance pit.

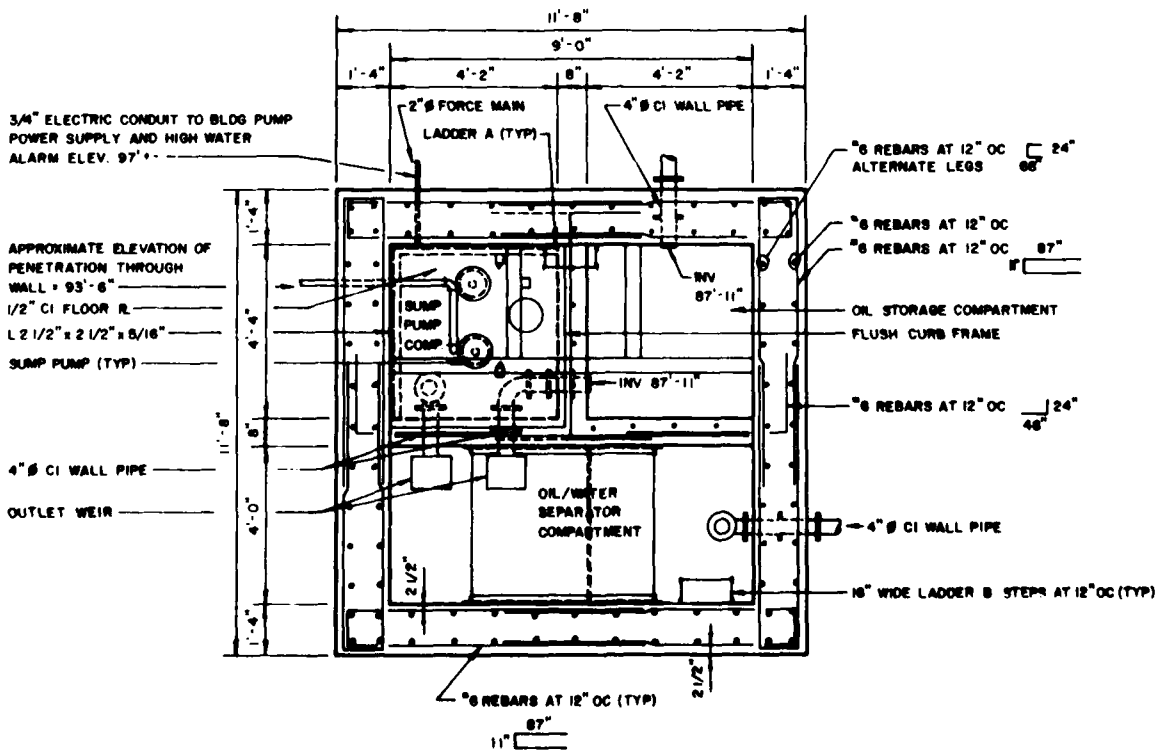

The oil and grease that accumulate on the water surface in the pretreatment system flow over a weir to the used oil storage chamber. Solids that collect in the settling chamber must be removed periodically with a vacuum truck or similar method. The solids storage volume of the chamber must be based on the characteristics of the waste stream and the planned frequency for removing the solids. Access must be provided to the settling chamber for solids removal.

The pretreated effluent is pumped to the sanitary sewer system. The most cost-effective solution at this particular maintenance facility was to pump the pretreated wastewater to the existing floor drainage system in the building. The bay that was renovated is at the extreme upper end of the floor drainage system. The discharge flow rates from the pretreatment system are easily handled by the existing floor drainage system, with the facility draining into a collection pit that acts as a secondary grit chamber and oil separator. Therefore, wastewater from the cleaning operations has two opportunities for pretreatment.

The existing floor drain lines were plugged and presented a problem during facility startup. However, since these lines were unplugged, they have been kept clean by the water from the pretreatment discharge pumps.

Analysis of the separator influent has shown it to contain 121.4 lb/gal suspended solids and 23.9 lb/gal oil and grease. The separator is removing 99 percent of the suspended solids and 95 percent of the oil and grease.

Waste Oil and Antifreeze Storage Facilities

Underground storage facilities for used oil and antifreeze are located just outside the building support and equipment area as shown in Figure 4. To determine the size of the required tanks, information was collected from base personnel, including the number and type of vehicles serviced, volumes of fluid waste generated by the various vehicle types, and the desired frequency of waste removal from the base. The storage tanks can be made of any number of various materials, but the choice can be limited if corrosive soils are found to be present. The tanks should be provided with handy access ports so that the level of the waste inside the tanks can be monitored and the waste pumped to disposal trucks for removal.

At Fort Carson, a chamber was built into the oil/water separator structure for waste oil storage. The vacuum truck that collects waste oil at Fort Carson can pump down only to a depth of about 14 ft. This means that the bottom 5 ft of waste cannot be emptied and that the truck must service this separator more often than originally planned. Future projects may consider using wider, more shallow storage chambers, or possibly installing a lift pump for the waste oil.

Electrical and Compressed Air Outlets

Electrical duplex outlets in the pits are located on the wall opposite the tool shelf at the ends and center of each pit section. These seven outlets should be more than adequate to handle any of the requirements of motorized tools or drop-cord lighting needed for service. In addition, three outlets are located in each workbench area above the work surface height. These are specific areas that should have a heavy concentration of outlets for access by maintenance personnel. All outlets are on a ground fault circuit and are of explosion-proof design. These explosion-proof outlets have been a problem for the

General illumination lighting in the pit is recessed into the concrete floor slab opposite the tool shelf. For general lighting, 150-W incandescent fixtures were used. Motor pool personnel have since stated that lights on drop cords are preferred for illuminating closeup work when doing maintenance. Thus, it is suggested that lights with retractable drop cords be hard-wired into the pits for future projects.

Compressed-air outlets are located at the two remote dispensing stations and at the dispensing station under the crossover between the pits. Retractable air hoses reach all areas of the maintenance bay.

Lessons Learned

Several important lessons were learned during this project, many of which have been discussed above. This section lists lessons learned not discussed elsewhere.

When analyzing the existing structure, it is essential to have good "as-built" drawings. During construction at Fort Carson, several conduits not on the drawings were discovered buried in the concrete being excavated. This finding added to the project cost and delayed progress.

Be aware that all additions and changes to a structure are subject to current design criteria and specifications, not to the criteria in effect when the building was constructed. Adapting building 1692 to current standards added considerable expense to the retrofit cost, largely due to safety, fire, and insulation specifications that were not in effect when the building was constructed.

In this retrofit, the crane would have been much more useful if it had covered two bays--the bay with the pit and the adjoining bay. Building 1692 was not wide enough to service two tracked vehicles with engine packs removed in one bay. Additional crane width would allow this activity.

The air-driven grease pump is not compatible with the standard issue grease containers available at Fort Carson. The pump that was installed fits a 55-gal drum. Although a 55-gal grease drum is listed as being available through Army supply channels, it is neither commonly used nor readily available. The building users improvised a solution to this problem which may be better than the original design. They used a compressed-air-driven 5-gal grease container with an applicator hose and gun. This container can be attached to any of the compressed-air hoses and used anywhere in the maintenance bay area.

During washing activities, overspray from the hoses must be prevented from entering dry working and storage areas. Thus, some type of movable curtain or partition is needed to isolate the wet maintenance areas from the dry.

The only drain to the used-oil storage tank is from the sliding oil pans in the pit. Another used-oil dump station is needed for general disposal.

No signage was provided as part of this project, other than labels for spigots, hoses, etc. Signs with concise instructions for use of the different equipment would have been

The fluorescent light fixtures installed above the workbench areas were not the standard-sized fixture used in the rest of the building. Thus, the battalion cannot replace broken or burned out tubes.

Despite these minor drawbacks and the fact that some maintenance features still are not in service, the facility users report a high level of satisfaction with the retrofit. They note that the new features are a great improvement over the former configuration.

Costs Analysis

The construction cost for this retrofit project was \$400,000. This figure includes neither the design costs nor Omaha District's expenses. The cost of a completely new, enclosed, SMF would range between \$250,000 and \$350,000. If this project were done again, some 20 percent of the cost could possibly be eliminated due to the lessons learned from the Fort Carson demonstration. Considering this fact, the cost of a similar project would be close to that of a new facility.

It is difficult to make a realistic comparison between the cost of this retrofit to that of new construction. Only one of the 12 TAC shop bays in building 1692 was altered for scheduled vehicle maintenance. Normally, it is recommended that three bays be retrofitted with maintenance pits to accommodate six vehicles at once. These three bays could then share the same mechanical and storage rooms that had to be installed in the single bay facility at Fort Carson. The cost per bay of a three-bay retrofit would be much less than that of a one-bay retrofit.

Another difficulty in comparing new and retrofit construction is the variety of TAC shop designs that occurs throughout the Army. For example, there are at least four different designs at Fort Carson. As was discovered in this project, the design details and as-built construction of the building being retrofitted have a definite effect on the cost of the retrofit. In one case, if building 1692 had had roll-up type vehicle entrance doors rather than overhead garage doors, more than \$10,000 in replacement costs could have been saved.

Most Army installations have existing TAC shops where retrofit SMFs would be decidedly more cost-effective than new construction. However, the situation must be determined on a case-by-case basis.

At the beginning of the project, it was believed that retrofit construction could be done with in-house resources. In practice, the cost of even this small-scale application has shown that the amount of funding required will probably prohibit a completely in-house project. It is unlikely that this type of project could be done outside of Military Construction, Army (MCA) funding, though it is a very good candidate for the Productivity Improvement Fund (PIF) program.

The SMF concept has proven cost-effective, and PIFs have already been used to fund SMFs, both as stand-alone facilities and as incorporated into new TAC shops. A general requirement for PIF projects is that the return-on-investment period be less than 2 years.

3 CONCLUSIONS AND RECOMMENDATIONS

The FTAT demonstration at Fort Carson has shown that retrofitting existing facilities such as TAC shops can be a feasible alternative to new construction. A retrofit facility can provide all of the same functions as a newly constructed SMF and may be more appropriate if found to be economically advantageous or if space and/or funding restrictions are in effect. At the time of this writing, some of the maintenance features in the retrofit are still not functional; despite this delay, the users are very happy with the overall facility. It is considered a tremendous improvement over the former arrangement.

All pollution control features are intact and functioning properly. The waste washwater and drained fluids are now handled in an environmentally sound manner. The pretreatment structure for the washwater removes up to 90 percent of the pollutant load prior to discharge to the sanitary sewer. According to the Fort Carson Environmental Office, the overall pollution control from maintenance activities has greatly improved.

In this demonstration, the retrofit cost somewhat more than would have been expected for new construction. However, it should be noted that numerous factors preclude a realistic comparison between retrofit and new construction. In addition, it is estimated that about 20 percent of the retrofit cost could be saved on future projects using the lessons learned from Fort Carson.

Based on this experience, it is recommended that installations where SMFs are being considered should look very carefully at retrofitting existing facilities. Some TAC shops would be favorable sites for retrofit construction.

Since the wastewater pretreatment used in this project seems to be effective in controlling pollution from scheduled maintenance activities, it is also recommended that this type of pretreatment be incorporated into all future SMF designs.

METRIC CONVERSION TABLE

1 in.	= 2.54 cm
1 ft	= 0.3048 m
1 lb/gal	= 0.1198 kg/L
1 gal	= 3.785 L
1 ton	= 907.185 kg

USA-CERL DISTRIBUTION

Chief of Engineers
ATTN: CEEC
ATTN: CEEC-C
ATTN: CEEC-E

USAEHSC, ATTN: Library 22060
ATTN: CEHSC-FU-S

US Army Engineer Districts
ATTN: Library (41)

US Army Engineer Divisions
ATTN: Library (13)

US Army Europe
AEAEN-ODCS/Engr (2) 09403
AEUES 09081
V Corps
ATTN: DEH (12)
VII Corps
ATTN: DEH (16)
21st Support Command
ATTN: DEH (12)
USA Berlin
ATTN: DEH (10)
USASETAF
ATTN: DEH
Allied Command Europe (ACE)
ATTN: ACSGEB/Engr
ATTN: SHIHG/Engr

8th USA, Korea (19)

ROK/US Combined Forces Command 96301
ATTN: EUSA HHC CFC/Engr

USA Japan (USARJ)
ATTN: DCSEN 96343
ATTN: Fac Engr 96343
ATTN: DEH-Okinawa 96331

416th Engineer Command 60623
ATTN: Facilities Engr

US Military Academy 10966
ATTN: Facilities Engineer
ATTN: Dept of Geography &
Computer Science
ATTN: MAEN-A

AMMRC 02172
ATTN: DRXMR-WE
ATTN: DRXMR-AF

US AMCCOM 61299
ATTN: AMSMC-RI
ATTN: AMSMC-IS

AMC - Dir., Inst., & Serve
ATTN: DEH (10)

DLA ATTN: DLA WI 22304

DNA ATTN: NADS 20305

FORSCOM
FORSCOM Engr, ATTN: Spt. Det.
ATTN: DEH (28)

HSC
Ft. Sam Houston AMC 78234
ATTN: HSLO-F
Fitzsimons AMC 80045
ATTN: HSHG-DEH

INSCOM - Ch, Instl. Div
ATTN: Facilities Engineer (5)

MTMC
ATTN: MT-LOF 20315
ATTN: Facilities Engineer (3)

NARADCOM, ATTN: DRDNA-F 01760

TARCOM, Fac. Div. 48090

TRADOC
HQ, TRADOC, ATTN: ATEN-DEH
ATTN: DEH (18)

TSARCOM, ATTN: STSAS-F 63120

USAIS, ATTN: Facilities Engr (4)

WESTCOM
ATTN: DEH, Ft. Shafter 96858
ATTN: APEN-A

HQ USEUCOM 09128
ATTN: ECJ 4/7-LOE

FORT BELVOIR, VA 22060 (11)
ATTN: Canadian Liaison Officer
ATTN: British Liaison Officer
ATTN: Australian Liaison Officer
ATTN: French Liaison Officer
ATTN: German Liaison Officer
ATTN: Water Resources Support Ctr
ATTN: Engr Studies Center
ATTN: Engr Topographic Lab.
ATTN: ATZA-TE-SU
ATTN: ATZA-TE-EM
ATTN: STRBE-BLURE

CECRL, ATTN: Library 03755

WES, ATTN: Library 39180

HQ, XVIII Airborne Corps
and Fort Bragg
ATTN: AFZA-FE-EE 28307

Area Engineer, AEDC-Area Office
Arnold Air Force Station, TN 37389

Chanute AFB, IL 61868
3345 CES/DE, Stop 27

Norton AFB, CA 92409
ATTN: AFRCE-MX/DE

AFESC, Tyndall AFB, FL 32403

NAVFAC
ATTN: Engineering Command (9)
ATTN: Division Offices (11)
ATTN: Naval Public Works Center (9)
ATTN: Naval Civil Engr Lab. (2)
ATTN: Naval Constr Battalion Ctr

NCEL
ATTN: Library, Code L08A 93043

Defense Technical Info. Center 22314
ATTN: DDA (2)

SETAF Engineer Design Office 09019

Engr Societies Library, NY 10017

Natl Guard Bureau Instl. Div 20310

US Govt Print Office 22304
Receiving Sect/Depository Copies (2)

US Army Env. Hygiene Agency
ATTN: HSHB-E 21010

National Bureau of Standards 20899

284
07/88