

AD-A198 754

DTIC FILE COPY

REPORT ON CONTRACT NUMBER DA JA45 87 C 0059

"PROCESSING OF MIXED OXIDE SUPERCONDUCTORS"

by A.M. Campbell and M.F. Ashby
Cambridge University Engineering Department
Trumpington Street, Cambridge CB2 1PZ UK

5909-MS-01

(2)

DTIC
ELECTE
AUG 04 1988
S D
H



High T_c superconductivity has continued to change at a rapid pace. Since the last report, two new compounds have been reported with even higher critical temperatures and possibly higher critical currents. Less encouraging is a recent experiment reported from IBM from which it appears that even clean low angle grain boundaries can limit the current densities. If confirmed this means that in future all practical conductors will have to consist of carefully aligned grains, probably melted in some way to fuse the boundaries together.

Fortunately, all the techniques developed in this project are applicable to a wide range of materials, but we have decided to postpone any more HIPing until we have prepared better orientated samples. Most of the work is described in the three enclosed papers and only the main conclusions will be summarised in this report. The topics are classified under four headings. (mjm) ←

1) Magnetic Separation (Paper about to be submitted)

It is clear that the magnetic forces on superconductors are quite complicated and the regimes will be quite different as a particle passes through a magnetic toroid. We have used the superconductor's magnetisation curve to make calculations of the force at all positions on the axis of a magnet, and found that the force goes through several oscillations. One curious result

DISTRIBUTION STATEMENT A
Approved for public release;
Distribution Unlimited

(1)

88 7 29 017

is that the superconductor can hang below the magnet as well as levitate above it. We have observed this experimentally and originally thought it due to the pinning of flux lines. In fact the explanation is much simpler. A toroidal permanent magnet has a zero in the field near both faces so the superconductor can sit on either of these zeroes. The knowledge gained from these calculations will be used to design a better separation apparatus.

II) Screening (Paper submitted to Superconductivity, Science and Technology).

We have made a theoretical calculation of the screening effect of a diamagnetic sheet, assuming no bulk currents are carried. The results show that thin sheets of a diamagnetic material are unlikely to be very effective screens, since demagnetising effects drive the material normal at low fields and a very small permeability is necessary to get any useful effect. Experiments are under way to test these predictions.

III) Magnetisation of Hollow Cylinders. (Papers given at Birmingham Meeting, submitted to Cryogenics).

This geometry allows us to separate out the two sets of currents flowing in High T_c Materials. There are large currents flowing within grains and small currents flowing between them. By measuring the flux in coils inside and outside the cylinders these two components can be separated.

This technique is working well and has shown that starting from nitrate precursors leads to a higher current density than starting from the carbonate.



Dist	
A-1	
Special	
Quality Codes	
And/or	
Classification	perform 50
Reduction	<input type="checkbox"/>
And	<input type="checkbox"/>
For	<input checked="" type="checkbox"/>

IV) Magnetisation of Powder

Since small grains of powder are probably the best single crystals we can obtain, they provide a good test of the inherent properties of this material. The results are not completely unambiguous but suggest that large currents can flow on the scale of the grains, that is to say up to 20μ . This means that twin boundaries are unlikely to be a problem. Measurements of flux creep show that electric fields are less than 10^{-11} V/m at current densities of 10^4 A/cm² so again it does not appear that flux creep will be a practical problem, although the measurements should be extended to higher fields.

Flux Trapping and Magnetisation of Hollow Superconducting Cylinders

F.J. Eberhardt, A.D. Hibbs and A.M. Campbell

Interdisciplinary Research Centre in Superconductivity, West Cambridge Site,
Madingley Road, Cambridge.

Abstract.

The magnetisation of hollow cylinders of high T_c material, and the field trapped inside them, has been measured by integrating the signal from coils outside and inside the cylinders. The two coils allow the field trapped in the grains themselves to be separated from the field due to the circulating currents.

The trapped field tells us the maximum field that can be expected in a magnet. If J_c drops rapidly with field the parameter which will determine the trapped field is not the zero field critical current density but the field at which it is reduced by half. A comparison is made of various preparation methods.

Introduction

Powders of yttrium barium copper oxide which have been compressed and sintered into a solid block show two superconducting pathways. One is confined to the individual grains (the intragrain current) and has a critical current density J_c of approximately 10^6 A/cm² at 4 K (1). The other can cross grain boundaries (the intergrain current), but has a much lower J_c in the materials fabricated so far. This is illustrated in figure 1. For practical purposes it is necessary to bring the intergrain current density up to the values achieved

within grains. When the material is exposed to a magnetic field the currents in the grains cause a magnetisation of the material, and the intergrain currents form a screening current. This is illustrated in figure 2.

A hollow cylinder fabricated out of this material is an interesting geometry for a number of reasons. In the first place it is possible to separate out the effects of the two currents, since the fields due to the flux in the core and the flux in the material are in the opposite sense in the core, but in the same sense outside the cylinder, as shown in figure 2. Secondly this geometry may be used for screening purposes. Thirdly it is easy to make, and it may be the most effective geometry for making permanent magnets, since it is a more efficient use of material.

Maximum screened field.

The critical current densities of these materials fall very rapidly in the presence of a small magnetic field (2). The fall is approximately exponential, and is illustrated schematically in figure 3. If a field of strength B_i is required in the core of a solenoid of this material the wire would be restricted to operate at the critical current density J_{ci} . In this case the field would fall off linearly in the wall of the solenoid.

In contrast a magnet made from a solid block of this material would have a field profile which was not linear. The critical current density in the material would start at J_{ci} in the centre and rise as the ambient field fell, reaching the zero field value of J_c at the outer edge. Hence the thickness of material required would be less. It is worth pointing out that if the fall of

J_c with applied field is approximately exponential an important parameter for these materials will be the value of field at which the critical current density has fallen to half the zero field value, as from this point the size of cylinder required to contain a larger field will rise exponentially also.

This follows from the critical state equation. If this field is denoted B_a the critical state equation is

$$\frac{dB}{dx} = \mu_0 J_{co} e^{-B/B_a}$$

where J_{co} is the zero field critical current density.

This has a solution

$$\mu_0 J_{co} d = B_a (e^{B_i/B_a} - 1)$$

It can be seen that when $B_i > B_a$ the wall thickness rises exponentially.

If the material were fabricated into wire the thickness of solenoid required to hold back the same field would be

$$\mu_0 J_{co} d = B_i e^{B_i/B_a}$$

The thickness of wall predicted from this equation is always larger than for the case where a solid block of material is used, since in the latter case the full potential of the material to carry currents between J_{ci} and J_{co} is being used.

In this work cylinders of sintered YBCO have been fabricated. Magnetic fields have been applied to these, and the fields inside and outside have been measured using coils.

Experimental Procedure

Yttrium barium copper oxide was made by mixing yttrium oxide, copperII oxide and either barium carbonate or barium nitrate in the correct stoichiometric proportions and firing at 950°C for several hours. The powders were ground and pressed into moulds to give cylinders of the approximate dimensions 8mm i.d., 14mm o.d. and 10 to 13mm long. Some powders were pressed dry, and some were wet with acetone to facilitate handling. All cylinders were annealed in flowing oxygen. Two further cylinders were fabricated from bismuth calcium strontium copper oxide to the stoichiometry (1:1:1:2).

The cylinders were cooled in liquid nitrogen and exposed to a magnetic field for about half a minute. Two coils were wound, each with 800 turns, one to fit into the core of the cylinder and the other to go outside it, (figure 4). The superconducting cylinder was lowered into the larger coil or passed over the smaller, inducing voltages which were integrated. The coils themselves were rather sensitive to movements in the earth's field, so were kept stationary.

The magnetisation of the bulk material can be modelled by considering it to be equivalent to two opposing current sheets on the inner and outer surfaces of the cylinder. (This implies that the magnetisation of each grain is the same). The signal in a coil is then given by

$$\int V dt = M (L_i - L_o)$$

Where M is the magnetisation of the sample, and L_i and L_o are the mutual inductances per turn between the search coil and closely wound coils on the inner and outer surfaces of the cylinder. The values of L are obtained from conventional inductances for coils with n turns per metre by dividing by n .

Similarly the signal due to the intergrain currents will be given by

$$\int V dt = J_c L_m$$

Where J_c is the critical current density of the intergrain current and L_m is the mutual inductance between the search coil and the superconducting material. In this case the calculation of the mutual inductance requires some assumptions to be made about the distribution of these intergrain currents in the material.

In the extreme case of an infinite cylinder the inner coil responds only to J_c and the outer coil to the sum of the currents. In finite sized coils the coupling is still different but to extract the values of J_c and M separately it is necessary to calculate the mutual inductances.

Mutual inductances were calculated using the published formulae and look-up tables (3). These formulae are for single layer coils. A computer program was written which treated each coil as a succession of concentric slices. Each slice was treated as a single layer coil of the appropriate mean radius and winding density, and the contributions from each layer in one coil to each layer in the other summed. The calculations were checked by measuring

the signal in a third coil, and the agreement between calculated and measured signals was within 7 %.

Results

In almost all samples the field in the centre coil was in the same sense as the applied field, indicating the presence of trapped flux. When a cylinder was slit axially, the bulk current pathway was interrupted and the signal changed sign.

It was originally assumed that since the critical current density falls so rapidly with applied field, almost all of it could be considered to be flowing in a region approximately 1/5th of the cylinder wall thickness around the outside edge of the superconducting cylinder. This assumption was checked using cylinders in which the signal had been measured both on a complete cylinder and one which had been slit axially. This revealed that the two coils gave comparable values for J_c if the currents were considered to flow in the region close to the centre surface of the cylinder wall. We believe that this is due to the fact that in these samples the magnetisation and trapped flux produce fields of similar magnitude in the centre, causing the net field experienced by the material to be lower on the inner surface than the outer surface.

The results are shown in the table below. Samples 1 to 3 were all made using barium carbonate as precursor. It can be seen that there is very little difference between those fabricated with the aid of acetone, and those which

were not. The handling of wet powder was much easier than dry powder. Critical current densities are low. However these are not zero field critical current densities. There is a field of up to 3 mT trapped in the core, as the cylinder walls are quite thick. The best sample used barium nitrate as the one of the precursor materials (sample 4). This had a critical current density 5 times better. Two cylinders were also made from the bismuth calcium strontium copper oxide material (1:1:1:2). One was ground to a powder and its diamagnetic susceptibility measured. This showed that the material contained both the high T_c phase (about 110K) and the lower T_c phase (about 85K), and the overall susceptibility was comparable to the material used in samples 1 to 3. The second cylinder was tested for trapped flux. No signal was detectable from the centre coil, and the outer coil gave a very small signal. This enables us to put an upper limit on M of 0.1mT, but we cannot say whether there are significant intergrain currents present. These results are consistent with magnetisation results (4).

Table of Results

Sample No.	Method of manufacture	J_c A/cm ²	Magnetisation mT
1	powder pressed dry	77	0.72
2	powder pressed wet	66	0.18
3	powder pressed wet	72	0.53
4	powder pressed dry (nitrate precursor)	370	1.7
5	bismuth compound	?	? 0.1

Conclusions:

The measuring technique developed can give values of intergrain currents and magnetisation without requiring contact to be made to the specimen. Like all measurements without a bias field there are considerable uncertainties, as the magnetisation is not itself constant in the presence of small fields. The geometry described is suitable for the manufacture of permanent magnets once critical current densities are raised to a more acceptable level. Although the bismuth compound is easier and cheaper to make than the yttrium compound, preliminary results suggest that it has exceedingly small critical current densities.

Acknowledgement: The authors would like to thank the U.S army for their support of this project.

References

1. Campbell A.M. , Hibbs A.D., Eberhardt J., Male S., Ashby M.F., Evetts J.E., Magnetisation and Critical Currents in High T_c Powders, presented to the conference on high T_c superconductivity, Boston, 1987.
2. Kupfer H., Apfelstadt I., Schauer W., Flukiger R., Meier-Hirmer R., Wuhl H., (1987) Z.Phys B 69 159
3. Grover F.W., 'Inductance Calculations', Dover Publications Inc., 1973.
4. Hibbs A.D., private communication.

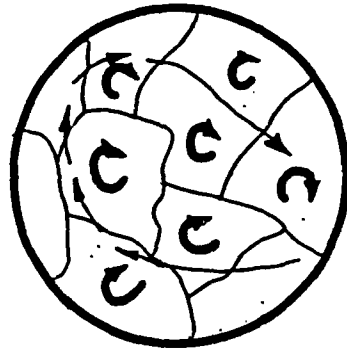

Large Currents Within Grains

Small Currents Between Them

Figure 1. Alternative current paths in yttrium barium copper oxide.

Original direction of
Applied field

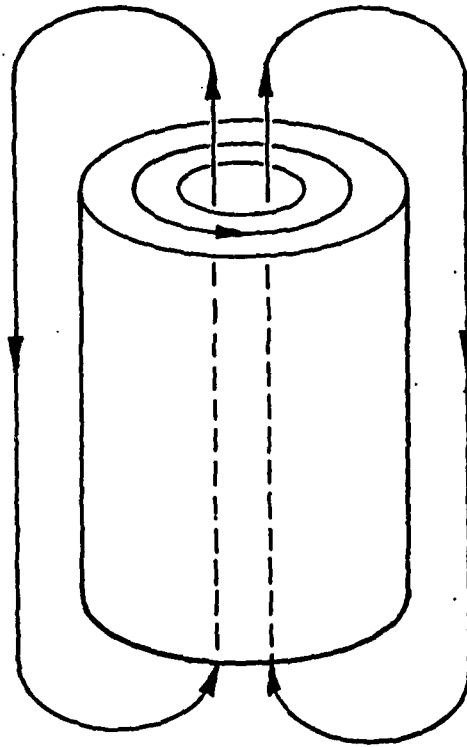

Figure 2. a) Circulating bulk currents trapping flux in the core.

Original direction
of Applied Field

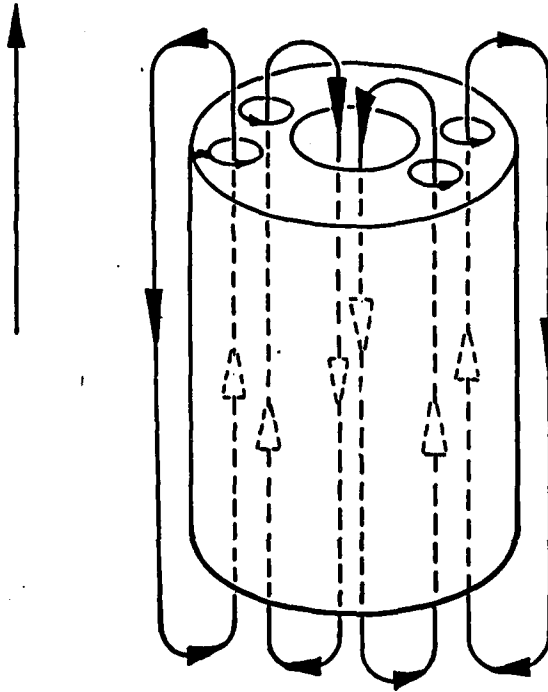
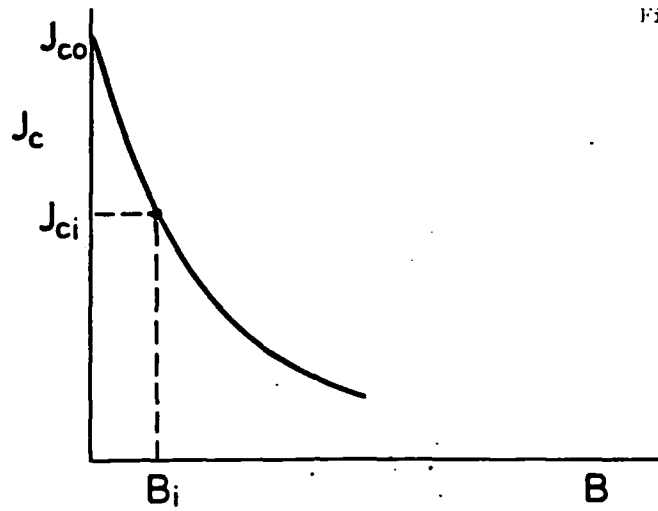

Figure 2 b) Currents in grains, giving a magnetisation of the material

Figure 3.



a) Fall in critical current density J_c with field.

(b)

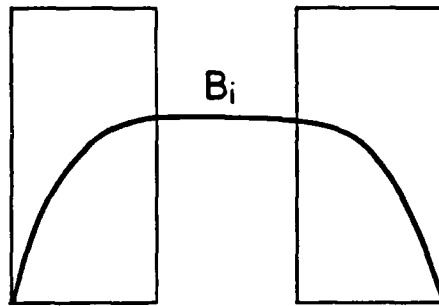

b) Profile of B in solid cylinder wall when a field B_i is trapped in the centre.

(c)

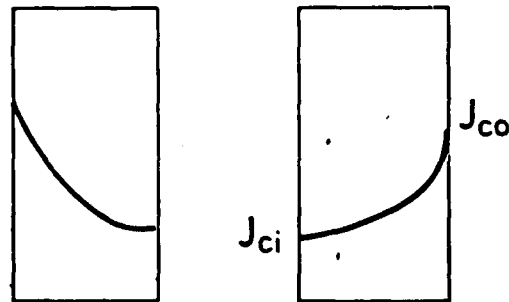

c) Profile of J_c in solid cylinder wall when a field B_i is trapped in the centre.

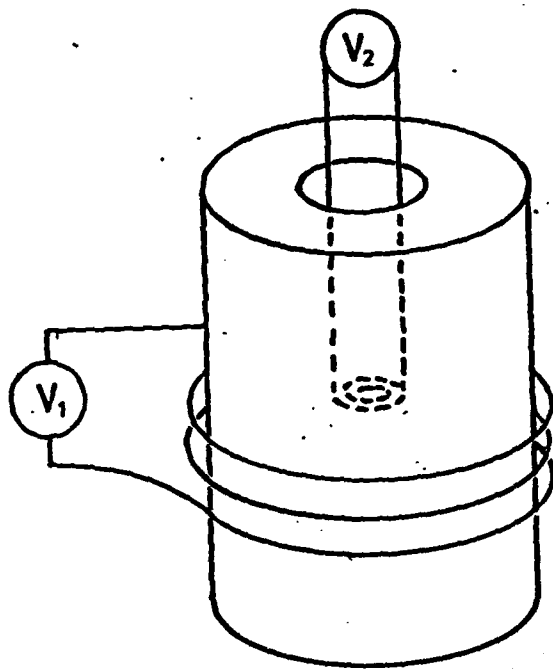

Figure 4. Arrangement of the measuring coils.

Magnetisation of High T_c Powders
A.D.Hibbs, F.J.Eberhardt and A.M.Campbell
Interdisciplinary Research Center in Superconductivity,
West Cambridge Site, Madingley Road, Cambridge.
and S.Male, C.E.R.L, Leatherhead, U.K.

The magnetisation of a series of different sized powders of YBa₂Cu₃O₇ has been measured. It is possible to interpret the results in two ways. The first that the penetration depth is rather large and the Bean model is applicable to the whole grain, and the second that there is a layer of "weak-link" or normal, non-superconducting, material 1 micron thick around each particle and the grains are subdivided.

Preliminary measurements on BiCaSrCuO indicate a very low value of H_{c2} and very little hysteresis.

Introduction

It is now widely believed that the transport critical current density in YBa₂Cu₃O₇ is limited by the grain boundaries and not by any barriers within the grains. However, evidence has been produced¹ which shows that large supercurrents do not flow unimpeded on the scale of a grain. In this paper we have taken a material with a large grain size, ground it up and separated it into different ranges of particle size. The magnetisation and ac diamagnetic susceptibility of these particles is then investigated.

Experimental Procedure

YBa₂Cu₃O₇ was prepared by the well known powder method using oxide precursors. In the second high temperature stage however, the pelletised sample was held at 950°C for eighty hours to increase the grain size to roughly 50µm. After grinding the powders were separated by an air jet sieve and cyclone into nine size ranges varying from 150-250 down to 10-15µm. Samples were sealed into glass tubes to prevent further exposure to the atmosphere.

Magnetisation curves at 77K were plotted directly using an integrating magnetometer in a field which swept between 0 and 1 tesla in approximately ten seconds. Much slower sweep rates of 10mT/sec were used to measure the initial gradients. The change in diamagnetic susceptibility (at 2.5kHz) was measured between the normal state at 100K and superconducting state at 77K.

Discussion of Results

The first thing to note is that the diamagnetic signals were not all equal. The initial gradients of the magnetisation curves showed a similar variation with particle size (fig.1)

There are three possible explanations:

a) The effect of penetration depth. The penetration depth, λ , causes a decrease in the magnetic size of the particle and if sufficiently large could explain the observed variations². Using an equation by London³, we see (fig.2) that a penetration depth of 1.5µm is consistent with our results. This is roughly three times the largest value quoted by ourselves⁴ and other workers⁵.

We can get another estimate of λ directly from the magnetisation curve. Taking $\mu_0 H_{c2}$ to be 3mT we have $\lambda = 0.5\mu\text{m}$. It is, however, very

difficult to get accurate values for H_c . The only way is to plot the magnetisation curve in increasing and decreasing field and sketch the reversible curve by hand. The magnetisation is strongly dependent on pinning and trapped flux and these vary with sample preparation, so it is not easy to get reliable results. Other authors have quoted $\mu_0 H_c$ as less than 2 mT giving $\lambda = 0.75 \mu\text{m}$. The effect of penetration increases only slowly with λ when the ratio of λ to the particle size to small and in this case a penetration depth of $0.5 \mu\text{m}$ will still give a ratio of largest to smallest signal of 1.5.

b) A coating of normal material. Diffusion at the surface of the grain may cause a layer of normal material to form. This could be CO , diffusing in or O_2 out. Alternatively an amorphous layer could be produced by grinding the samples. In both cases, the thickness of the layer will be independent of particle size. The magnetisation we measure is just from the remaining superconductor. In this case:

$$M = M_s (4/3\pi a^3 - 4\pi d a^2) / 4/3\pi a^3 = M_s (a - 3d) / a$$

We see that a $1 \mu\text{m}$ layer of normal material is consistent with our data (fig. 3). This seems rather large but it may be indicative of the effects of storing powders or the powdering process itself.

c) A coating of "weak-link" material. If the powders are sintered, bulk currents are low owing to weak links between the grain. It is possible that the region causing these is quite thick as it is probably due to diffusion as in b). For very low fields, as used in the a.c. susceptibility measurements, the weak links will remain superconducting and the particles will not appear smaller. However the penetration depth of the weak link material is much longer and the material will still be fully penetrated and so be magnetically invisible. The higher fields used in the initial gradient and hysteresis measurements simply drive the weak material normal.

The raw data of our hysteresis measurements is shown plotted against particle size in fig. 4. If the penetration depth is the cause of the observed variation in initial gradient, then the data needs no adjustment. The hysteresis is proportional to the particle size up to a radius of 40-50 μm - twice the grain size. The Bean model may be applicable on the scale of the grains. However if there is a layer of normal or weak link material which has been driven normal, present around each grain, then we must divide the hysteresis by the initial gradient of the respective curve. The hysteresis is now roughly independent of particle size, although there is much more scatter in the data. This means that the grains are subdivided on a scale smaller than 10 μm .

If we assume that the twins are acting as barriers to current flow and take an average twin spacing of 0.25 μm then the predicted critical current, J_c , is $3 \times 10^4 \text{A/cm}^2$. This is equal to that of the best thin films¹⁰. However using the complete grain we calculate $J_c = 7 \times 10^4 \text{A/cm}^2$, which is in good agreement with the values quoted for powders by other authors¹¹. It must be noted, that we expect J_c for powders and small crystals to be approximately two orders of magnitude less than for thin films. This is due to the anisotropy of J_c and the way in which the measurements are made. For thin films, J_c is measured resistively in the a-b plane whereas for powders magnetisation is used. Now in magnetisation measurements, the current must flow in the c direction for at least some of its path in almost all of the particles. As J_c is roughly one hundred times less in this direction there is a corresponding difference for powders and films.

Also if we take the twin spacing as our length scale the current density predicted at 4.2K is $>10^8 \text{A/cm}^2$, which is greater than the depairing limit sometimes quoted". In making the extrapolation from 77K to 4.2K, we have assumed $J_c = H_c = B_c$ and B_c to be 110 and 10T at 4.2K and 77K respectively.

We also observe (fig,4) that the hysteresis of small powders falls off more with increasing field than for larger powders, for which it is almost constant. Using a similar model to hypothesis b we see that these results are consistent with an extra $0.5 \mu\text{m}$ layer of material being driven normal by the increase in field. Hence there is some separate evidence in support of hypothesis c) of a worsening of superconducting properties at the surface of the particles.

BiCaSrCuO

The magnetisation of BiCaSrCuO is very much lower than the $\text{YBa}_2\text{Cu}_3\text{O}_7$ powders. The hysteresis was less than the noise in the system but an upper limit of 0.15mT could be set for H_c . Although 25% of the material was superconducting at 77K and the resistance was zero at 85K, the material would not levitate. Almost all the superconductor in this sample was the high temperature phase.

Conclusion

We have observed evidence that the Bean model is applicable in grains of $\text{YBa}_2\text{Cu}_3\text{O}_7$. However our results are also consistent with a layer of normal or weak-link material around each particle. It also seems likely that the superconducting properties lessen near the surface of the material.

Measurements on BiCaSrCuO indicate that superconductivity in this material may be a two dimensional phenomenon. However, the very small hysteresis may simply be due to the low density of twins and the resulting paucity of pinning centres.

Acknowledgements

We wish to acknowledge the United States Army for their support of this work.

References

- 1 M.Daumling et al:Appl.Phys.Lett.52,p.590 (1988)
- 2 D.Shoenberg:Proc.R.Soc.London,Ser.A 175 (1940) 49
- 3 F.London:Superfluids (Dover,New York,1961) Vol 1,Chap.4,p.34
- 4 A.M.Campbell et al:Mat.Res.Soc.Symp.Proc.Vol 99 p.883
- 5 Weismann et al:Ibid,p.387
- 6 V.Ottoboni et al:IEEE Trans.on Magn.March 1988
- 7 Peyral et al:Interlaken Conference on High T_c Superconductors
- 8 C.P.Bean:Rev.Mod.Phys,36 (1),31 (1964)
- 9 Fisanick et al :Mat.Res.Soc.Symp,Proc.Vol 99,p.703
- 10 Sumitomo Electric:Nature Vol.331,p.105,14/1/88
- 11 Kupfer et al:Meeting On High T_c Superconductors,Mauterndorf,Austria 7-11 Feb 1988
- 12 B.Oh et al:Appl.Phys.Lett.,51,852 (1987)
- 13 E.A.Hewat et al:Nature Vol.333,p.53,5/5/88

Fig. 1 Initial Gradient and Inductive Signal at 77K

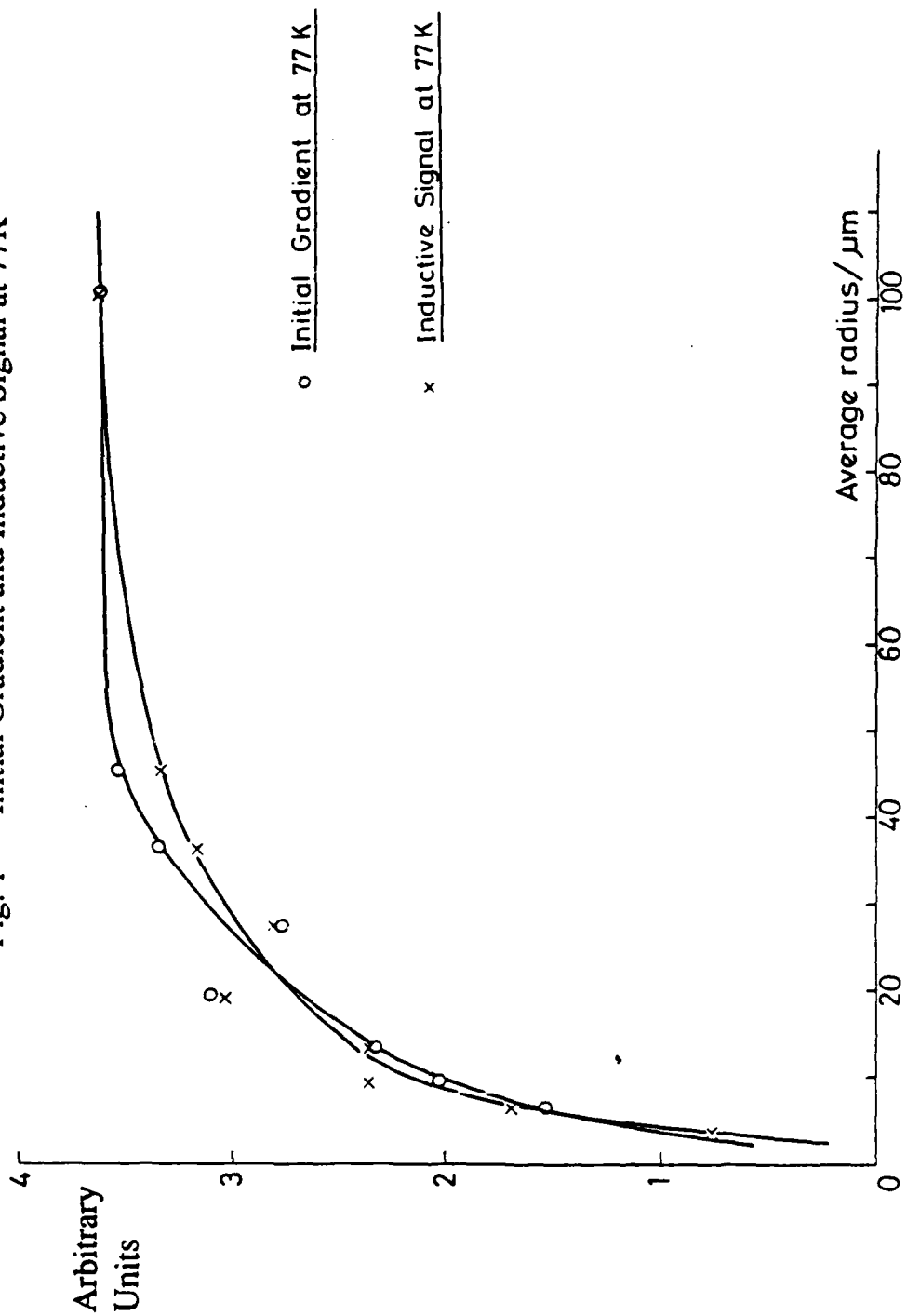
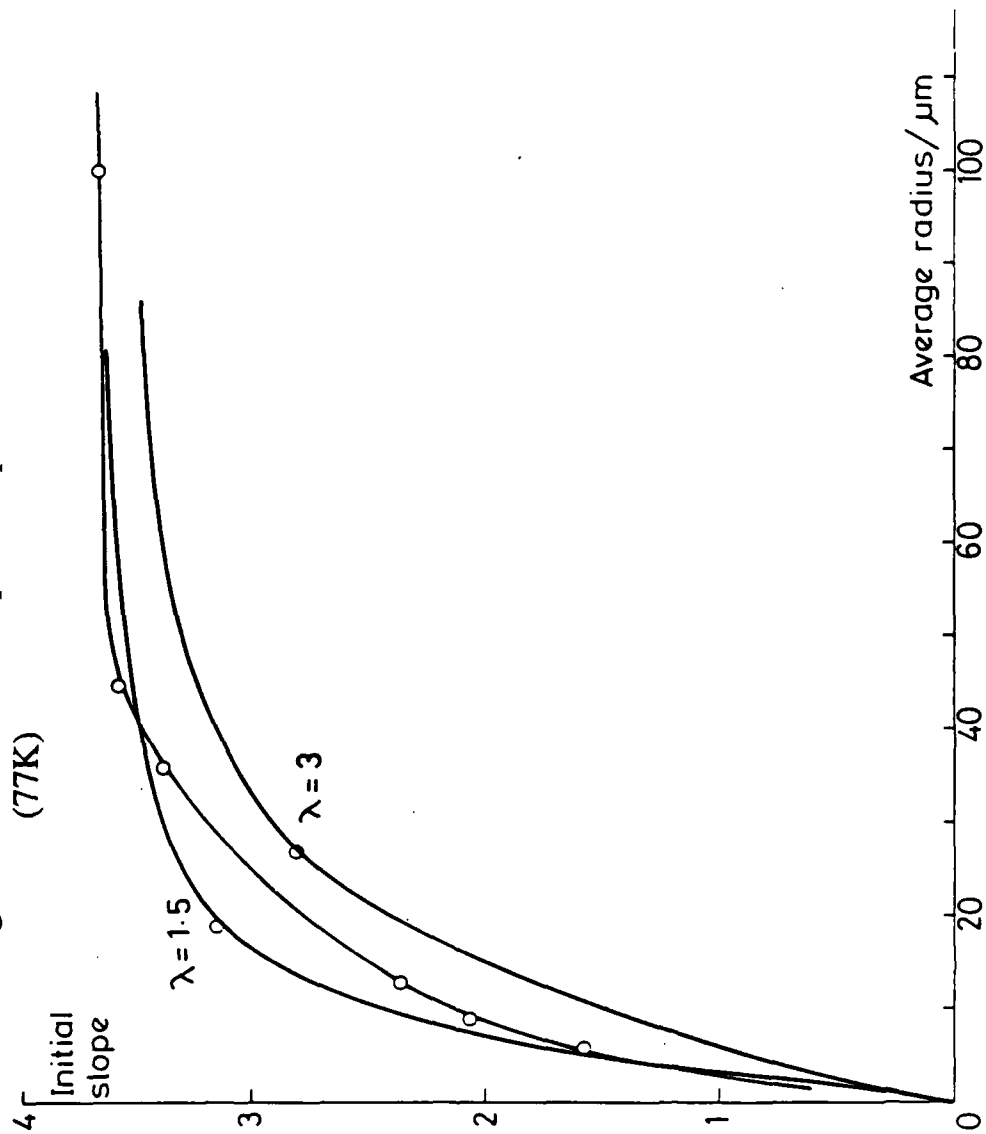

Fig. 2 Penetration Depth Compared to Initial Gradient
(77K)



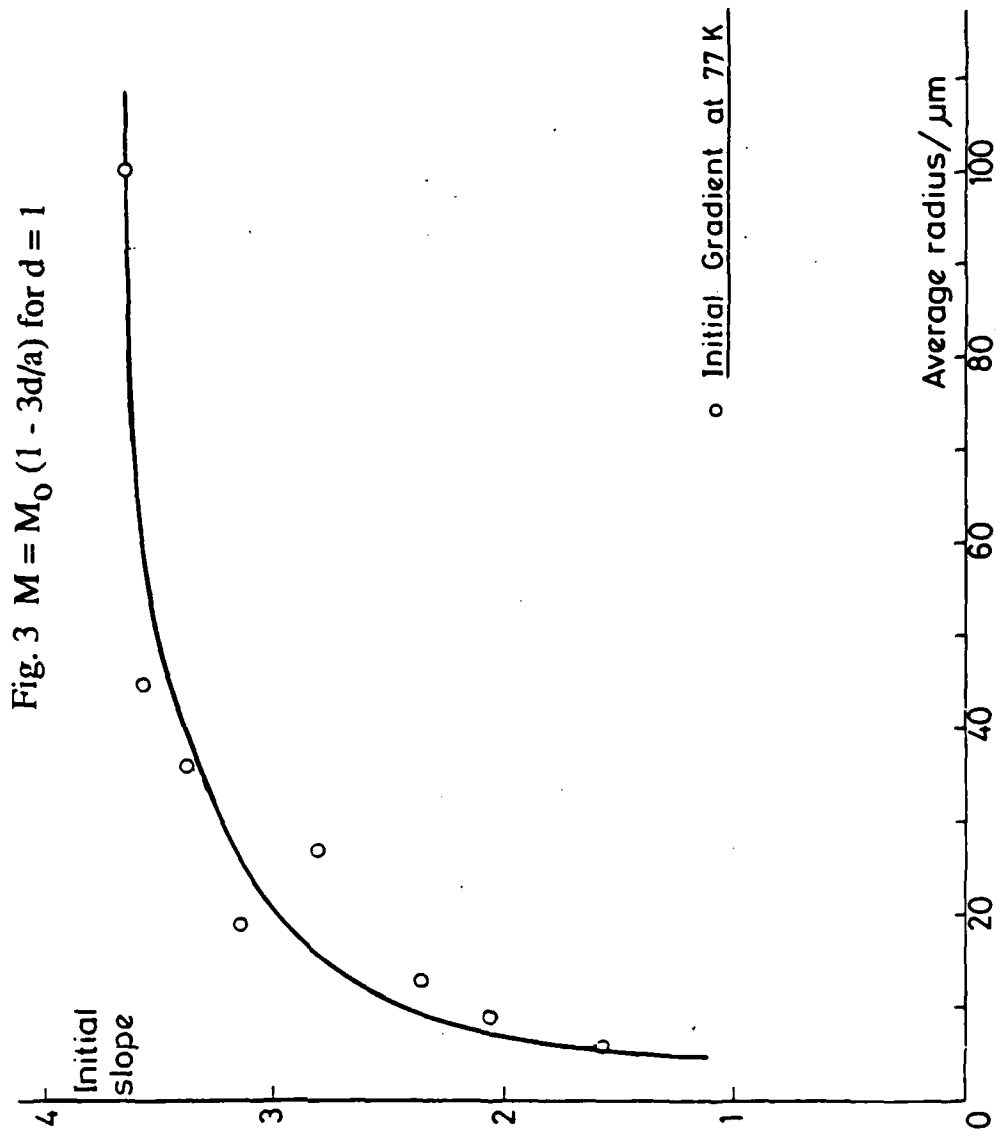
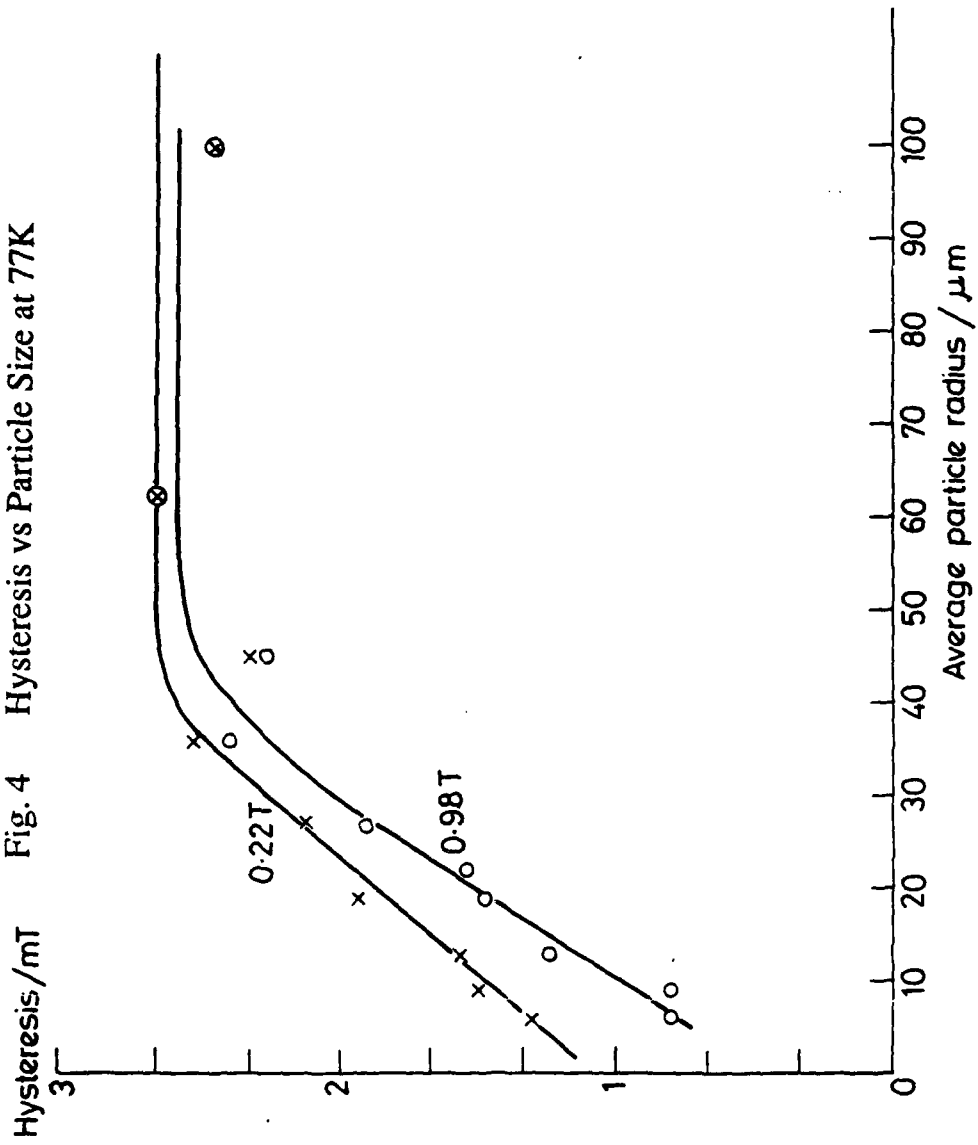
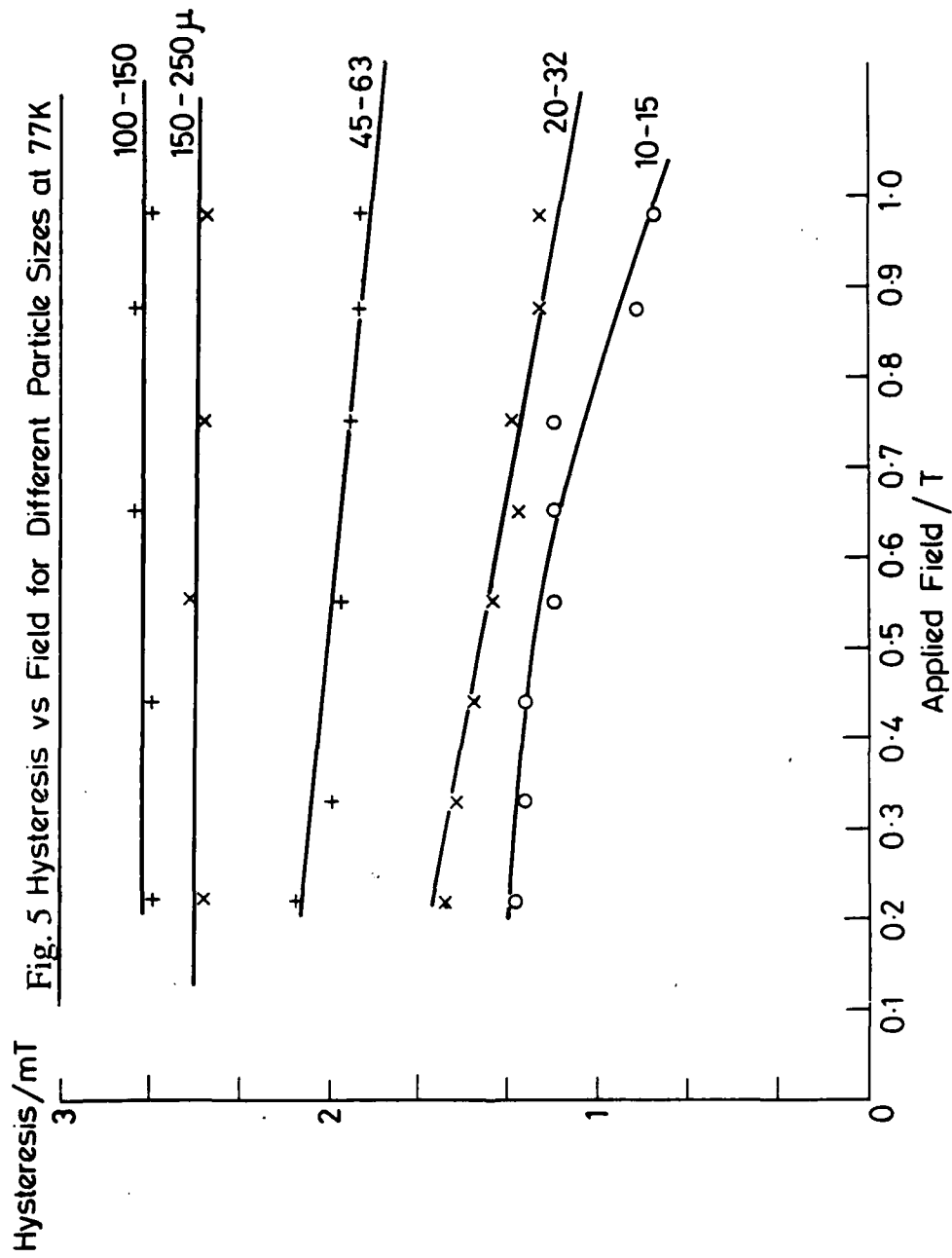

fig 3

Fig. 4 Hysteresis vs Particle Size at 77K





230

SCREENING BY HIGH T_C SUPERCONDUCTORS

A.M. Campbell

Interdisciplinary Centre for Superconductivity

West Cambridge Site, Cambridge, UK

ABSTRACT

An analysis is made of the screening of low frequency magnetic fields by high T_C superconductors. Screening can occur either through the cumulative effect of a composite of isolated diamagnetic particles, or by the induction of bulk transport currents if the particles are connected. In the former case it is possible to define a screening parameter $s = t/\mu a$ where t is the screen thickness, μ the permeability and a the size of the system. There is only significant screening if the parameter is large. Even when screening is significant demagnetising effects put a rather low limit on the maximum field that can be screened so the conclusion is that screens made up of insulated superconducting particles are likely to be of very limited application.

INTRODUCTION

The diamagnetism of high T_c superconductors is divisible into two components. One is due to currents passing between grains, the other to currents within grains. Since it is proving very difficult to carry high currents between grains it is of interest to determine how useful an array of independent diamagnetic grains might be for the purposes of screening and levitation. Screening due to transport currents must be treated separately.

FIELDS IN COMPOSITE SUPERCONDUCTORS

It is first necessary to establish the extent to which the classical theory of permeable materials can be used. A reversible Type II superconductor of any shape can be treated as an ordinary magnetic material provided we define H for any value of B as the external field in equilibrium with that B in a long cylinder parallel to the field (1,2). The magnetisation, M , is then defined in the general case as $B/\mu_0 - H$. If we make a composite consisting of isolated particles of this material we can still use the same expressions and definitions. We define B as the average flux density over a region large compared with the particle spacing and obtain the B - H curve by measuring the flux density in a sample of zero demagnetising factor.

If, as is normally the case, the magnetisation is dominated by hysteretic effects the theoretical arguments based on thermodynamic equilibrium break down, but the magnetic behaviour does not depend on the assumptions of equilibrium provided the

field is changed monotonically. The behaviour of a material consisting of insulated particles depends only on local values of B and the $H(B)$ curve, as measured on a long thin sample, if we now define H as the external field in this experiment. We can then imagine a reversible material with any $H(B)$ curve we like and choose one identical to the increasing (or, if appropriate, decreasing) curve of the irreversible superconductor. The irreversible material will behave in the same way as the imaginary reversible material provided there are no regions in which the local currents reverse, and provided we do not try to use expressions involving the entropy of the system.

To make the problem tractable we can split the magnetisation curve into three regimes. At low fields the material is linear and reversible with a small permeability. This holds up to a value of H where the magnetisation goes through a maximum. We shall call this H_m . At higher fields the material can be regarded as a permanent magnet with a magnetisation determined by the applied field. This magnetisation is small compared with H and will be positive or negative according to whether the external field has been increased or decreased. It does not change rapidly with field

THE PERMEABILITY OF COMPOSITES

The permeability of a composite is not easily calculated in the most general case. For a dilute array we can add up the moments of individual particles in the applied field and extend the range of validity by using the Lorentz theory of dielectric constants. The result for a volume fraction f of spherical particles is $\mu = 1 - 3f/(f + 2)$.

A concentrated array is more likely to be of practical interest and we can calculate the permeability of a set of superconducting cubes with a thin air space between them provided we apply the field perpendicular to the cube faces. If the gap between each cube face is $2d$ and the cubes have side a , the permeability is just the area fraction of free space on a cross section. i.e. $\mu = 4da/a^2$. The volume fraction is given by $1-f = 6da^2/a^3$ so $\mu = (2/3) (1-f)$. More complex geometries are best worked out by using the analogue of an array of electrical conductors in place of the interstices between the grains, but the effect will only be to change the $2/3$ into another similar factor. It should be remembered when working out the effective volume fraction at high densities that even if the grains are touching there is an effective air space equal to twice the penetration depth between the grains.

SCREENING

We assume the material is linear with a permeability μ .

Case (i) A spherical shell of superconductor in a uniform external field H_0 .

This can be solved exactly by using a magnetostatic potential containing dipole and uniform field terms and matching boundary conditions at the inner and outer radii. If the external radius is a , and the internal radius is b , then the interior has a uniform field H_1 given by

$$\frac{H_o}{H_i} = 1 + \frac{2}{9\mu} \left[1 - \frac{b^2}{a^2} \right] (\mu - 1)^2$$

If we put $t = a - b$, and assume both small μ and small t/a this expression reduces to:-

$$\frac{H_o}{H_i} = 1 + \frac{2t}{3\mu a}$$

In order to get significant screening we must have $\mu \ll t/a$. To take a specific example if the thickness is 10% of the external diameter and $\mu = .01$ the field is reduced by a factor of 8. It can be seen that the material must be very close to complete densification if reasonable screening factors are to be obtained. Since there is inevitable penetration of each particle by λ , as well as the distance occupied by currents in the grains, it is also important not to use very small sized particles.

We shall define the screening factor s by $s = t/\mu a$, i.e. the relative thickness of the screen divided by the mean permeability. A similar parameter can be defined for most geometries. In this case if s is large the field is reduced by a factor $2s/3$.

The maximum field that can be screened is considerably smaller than the peak of the magnetisation curve. If t/a and μ are both small the maximum value of the effective H in the material is $H_o \left[\mu + \frac{2t}{3a} \right]^{-1}$. For small s the internal field is increased by a factor $1/\mu$ and for large s it is increased by a factor $1.5a/t$. For the example given above it is $15H_o$. Hence the maximum field that can be screened is about $H_m/15$ or typically 1.mT. This can be understood from the fact that the energy available to exclude the field depends on the volume of

superconductor, so thin shells cannot exclude such large fields as solid spheres. Results for cylinders are qualitatively similar to those for spheres.

Case (ii) Magnet inside a Diamagnetic Shell.

This can also be solved exactly in a similar way, and the results are similar to those of section (i). The ratio of the dipole moment without screening to that measured outside the screen is $1 + \frac{2}{9\mu} [\mu-1]^2 \left[1 - \frac{b^2}{a^2}\right]$. This is the same as the screening factor for the uniform external field. The factor by which H is increased in the material is also the same as in section (i).

Case (iii) Infinite Sheet

If the magnet is placed close to an infinite flat sheet, we can find the field on the other side of the sheet. There are a number of different configurations, but the basic problem is the same as that of a point charge above a dielectric sheet. To obtain the results for the magnetic case it is only necessary to replace E by H and ϵ by μ . The solution can be found in Smythe (3). If we put a charge q at the origin and a sheet of thickness t and dielectric constant ϵ perpendicular to the z axis, the field on the other side of the sheet is:

$$\frac{q}{4\pi\epsilon_0} \frac{[1-\beta^2]}{\int_0^\infty \frac{k J_0(k\rho) e^{-kz}}{1-\beta^2 e^{-2kt}} dk}$$

where $\beta = (\epsilon - 1)/(\epsilon + 1)$ and ρ is the radial distance from the z axis. This can be written as the sum of the fields due to a set

of image charges by expanding the bottom line with the binomial theorem. The potential is:-

$$\frac{q(1-\beta^2)}{4\pi\epsilon_0} \left[\frac{1}{(z^2 + \rho^2)^{3/2}} + \frac{\beta^2}{((z+2t)^2 + \rho^2)^{3/2}} + \frac{\beta^4}{((z+4t)^2 + \rho^2)^{3/2}} \dots\dots(1) \right]$$

Notice that this does not depend on the position of the screening sheet. Only the distance to the charge, z , is relevant. This expression can be applied directly to a magnet with widely separated poles, each of which behaves like a point charge but similar results will be obtained for other shapes. The image system, which is always valid, consists of a charge reduced by $(1 - \beta^2)$ in the original position, with charges $\beta^2(1 - \beta^2)$ at $z + 2t$, $\beta^4(1 - \beta^2)$ at $z + 4t$ etc.. This applies to all magnets and coils. The maximum screening is with the magnet touching the screen and the test point immediately on the other side of the screen. Then $z = t$ and $\rho = 0$ and if $\beta=1$ the series can be summed. We find that the field on the axis is reduced by a factor 4.9μ . If $z \gg t$ the exponential on the bottom line can be approximated to $(1-2kt)$ and the integral becomes

$$\frac{q}{4\pi\epsilon_0 z^2} \int_0^\infty \frac{x e^{-x} dx}{1 + sx/2}$$

where $s = (\epsilon-1)^2 t / \epsilon z$. The screening factor for this geometry, using superconductors is $s = (\mu-1)^2 t / \mu z$

It can be seen that for small μ the value of the integral depends on $t/\mu z$. This is a similar factor to the one appearing in the screening by complete shells, with the distance to the magnet replacing the shell radius. For small values of s the

field is reduced by a factor $(1 - s)$. Numerical integration shows that in general the field is reduced by about 0.6 when $s \approx 1$ and the minimum is the value derived above, 4.9μ , when both magnet and test point are touching the screen.

The demagnetisation effects in the spherical solution also appear in this geometry. For this purpose the appropriate z is the distance from the magnet to the screen. For $z \ll t$ the field in the superconductor is increased by a factor $2/(1 + \mu)$. For small t the factor is $1/\mu$ for small s and $2z/t$ for large s . A reasonable approximation is a factor $1/(\mu + t/2z)$. Thus thin sheets can be driven beyond H_m even if the field was much less than this before the screen was inserted.

SCREENING OF COILS

A common arrangement for detecting superconductivity is to insert a sheet of the material between two thin coils and measure the mutual inductance between them. The argument used to justify a series of images is valid for coils as well as charges, but the values of mutual inductance are more difficult to calculate and another variable, the ratio of diameter to spacing, is involved.

The set of primary coils seen by the secondary is derived from the series in equation (1). If the sheet is of thickness t and the coils are z apart it consists of coils of strength $(1-\rho^2), \rho^2(1-\rho^2), \rho^4(1-\rho^2)\dots$ situated at $z, z+2t, z+4t \dots$ respectively. Values of mutual inductance can be obtained from reference (4) and the series summed numerically for any particular case. We summarise the general conclusions here.

Firstly, if the spacing of the coils is large compared with their radius they behave as two magnetic dipoles and all the

results of the earlier sections can be used. If the coils are close compared with their radius, the inductance of the image coils does not change much until they are further apart than their radius. The number of terms for which this holds in the series of equation (1) is of order r/t where r is the coil radius. If we cut off the series at this point, the field is reduced by $1-\beta^{2n}$ where $n \approx r/t$, but with a minimum value of 1. This works for both small values of β and for $\beta \approx 1$. In this latter case $\beta \approx 1-2\mu$ and the field is reduced by $\mu r/t$. This fits in with previous geometries if the relevant size in the screening factor is the coil radius.

These results apply to an infinite sheet and sheets of a diameter comparable to the coil diameter, require more detailed analysis.

The general conclusion to be drawn is that a material made up of individual superconducting grains is not a very effective screen. Firstly the permeability must be very close to zero if the screen is to be thin compared with the dimensions of the screened space. Secondly, if good screening is achieved by a thin sheet it follows that the value of H is greatly increased in the material so that the magnitude of field that can be screened without driving the material over the peak in the magnetisation curve is very small.

Experiments on levitation are normally carried out with rather thick sheets. The magnitude of the image magnet becomes small if s becomes small, (the relevant distance z is from the magnet to the sheet), and for $s=1$ the image strength is about 1/3 of the levitated magnet. Most levitation takes place at distances comparable with the thickness of the superconducting layer, so

quite high permeabilities are tolerable. Films under ten microns are unlikely to cause levitation without transport currents being carried. Only very small magnets could get close enough and then the high field near the pole pieces will drive the film beyond H_m .

SCREENING USING TRANSPORT CURRENTS

If currents can be carried over macroscopic distances these will provide much more effective screening. The current densities required can be calculated easily in the situations above. For example a current of $I \sin \theta$ A/m flowing in a spherical shell produces a uniform field inside of $2I/3$ A/m. Hence to screen out a field of H_0 we need a maximum current $1.5H_0$ A/meter so the current density is $J_c = 1.5 H_0/t$ where t is the screen thickness. In general a field of H_0 can be screened by a screen of thickness t where $J_c t \approx H_0$. However the very rapid variation of J_c with H_0 in high T_c superconductors leads to an effective limit on the field that can be screened.

While the current density is dominated by normal barriers it will vary approximately exponentially with field. Suppose $J_c = J_{c0} \exp(-H/H_A)$ where H_A is a constant dependent on the nature and thickness of the weak links. Then if we consider the field distribution across a slab of superconductor parallel to the field

$$\frac{dH}{dx} = J_c = J_{c0} \exp(-H/H_A)$$

if $H = 0$ at $x = 0$ the solution is

$$J_{c0} x = H_A \{ \exp(H/H_A) - 1 \}$$

This means that for fields greater than H_A the thickness of the screen rises exponentially so that the effective limit for

screening is H_A . This is also the maximum field that can be generated in a magnet wound with wire of the same material. Thus for practical applications to magnets the most important parameter is not the zero field critical current density, but the field at which J_c falls to about half this value.

Acknowledgements

I would like to thank the U.S. Army for helping to support this work.

References

- 1) Josephson, B.D., 1966, Phys. Rev. A, 152, 211.
- 2) Campbell, A. M. and Evetts, J.E., 1972, Adv. in Phys, 21, 199.
- 3) Smythe, W.R., 1968, 'Static and Dynamic Electricity', McGraw-Hill, 1968, p192.
- 4) Grover, F.W., 1973, 'Inductance Calculations', Instrument Society of America'.