

THE FILE COPY

(4)

OFFICE OF NAVAL RESEARCH
Contract N00014-82-K-0576

Technical Report No. 40

THE ROLE OF SURFACE BONDING ON LIQUID CRYSTAL
ORIENTATIONAL ORDERING AT METAL SURFACES

by

P. N. Sanda, D. B. Dove, H. L. Ong
IBM Research Division
T. J. Watson Research Center
P. O. Box 218
Yorktown Heights, New York 10598

S. A. Jansen
Department of Chemistry
Temple University
Philadelphia, PA 19122

R. Hoffmann
Department of Chemistry
Cornell University
Ithaca, New York 14853

July 1988

Reproduction in whole or in part is permitted
for any purpose of the United States Government

This document has been approved for public release
and sale; its distribution is unlimited

AD-A198 808

DTIC
SELECTED
AUG 02 1988
CD

REPORT DOCUMENTATION PAGE

1a. REPORT SECURITY CLASSIFICATION			1b. RESTRICTIVE MARKINGS			
2a. SECURITY CLASSIFICATION AUTHORITY			3. DISTRIBUTION / AVAILABILITY OF REPORT			
2b. DECLASSIFICATION / DOWNGRADING SCHEDULE						
4. PERFORMING ORGANIZATION REPORT NUMBER(S) #40			5. MONITORING ORGANIZATION REPORT NUMBER(S)			
6a. NAME OF PERFORMING ORGANIZATION Department of Chemistry		6b. OFFICE SYMBOL (If applicable)		7a. NAME OF MONITORING ORGANIZATION ONR		
6c. ADDRESS (City, State, and ZIP Code) Cornell University Baker Laboratory Ithaca, NY 14853-1301			7b. ADDRESS (City, State, and ZIP Code) 800 Quincy St., Arlington, VA			
8a. NAME OF FUNDING / SPONSORING ORGANIZATION Office of Naval Research		8b. OFFICE SYMBOL (If applicable)		9. PROCUREMENT INSTRUMENT IDENTIFICATION NUMBER Report #40		
8c. ADDRESS (City, State, and ZIP Code)			10. SOURCE OF FUNDING NUMBERS			
			PROGRAM ELEMENT NO.	PROJECT NO.	TASK NO.	WORK UNIT ACCESSION NO.
11. TITLE (Include Security Classification) The Role of Surface Bonding on Liquid Crystal Orientational Ordering at Metal Surfaces						
12. PERSONAL AUTHOR(S) P. N. Sanda, D. B. Dove, H. L. Ong, S. A. Jansen and R. Hoffmann						
13a. TYPE OF REPORT Technical Report #40		13b. TIME COVERED FROM _____ TO _____		14. DATE OF REPORT (Year, Month, Day) July 20, 1988		15. PAGE COUNT
16. SUPPLEMENTARY NOTATION						
17. COSATI CODES			18. SUBJECT TERMS (Continue on reverse if necessary and identify by block number) <i>Chromophore</i>			
FIELD	GROUP	SUB-GROUP				
19. ABSTRACT (Continue on reverse if necessary and identify by block number) The alignment of a nematic liquid crystal, 4'-n-pentyl-4-cyanobiphenyl (5CB), on several smooth metal (Cr, Cu, Ag and Au) surfaces was observed experimentally. Perpendicular (homeotropic) induced alignment was observed for Cu and Ag boundary layers, whereas parallel alignment was observed for Cr and Au. These differences are discussed in relation to the differences in chemical bonding interactions at the surfaces as described by theoretical calculations performed for the cases of Cu, Cr, and Au. Several differences in orbital interactions, as well as a sensitivity to bonding configurations, are illustrated with the aid of extended Hückel calculations on hypothetical organometallic complexes and extended Hückel/tight binding calculations of the interface for parallel versus perpendicular adsorbate orientations.						
20. DISTRIBUTION / AVAILABILITY OF ABSTRACT <input checked="" type="checkbox"/> UNCLASSIFIED/UNLIMITED <input type="checkbox"/> SAME AS RPT <input type="checkbox"/> DTIC USERS				21. ABSTRACT SECURITY CLASSIFICATION		
22a. NAME OF RESPONSIBLE INDIVIDUAL Roald Hoffmann			22b. TELEPHONE (Include Area Code) 607-255-3419		22c. OFFICE SYMBOL	

Submitted to
Phys. Rev. A

**The Role of Surface Bonding on Liquid Crystal
Orientational Ordering at Metal Surfaces**

P. N. Sanda, D. B. Dove, H. L. Ong,

IBM Research Division

T. J. Watson Research Center

P.O. Box 218, Yorktown Heights, New York 10598

S. A. Jansen

Department of Chemistry

Temple University

Philadelphia, Pennsylvania 19122

R. Hoffmann

Department of Chemistry

Cornell University

Ithaca, New York 14853



Handwritten 'J' in the top right corner of the stamp area.

Handwritten 'A-1' in the bottom left corner of the stamp area.

Abstract

The alignment of a nematic liquid crystal, 4'-n-pentyl-4-cyanobiphenyl (5CB), on several smooth metal (Cr, Cu, Ag and Au) surfaces was observed experimentally. Perpendicular (homeotropic) induced alignment was observed for Cu and Ag boundary layers, whereas parallel alignment was observed for Cr and Au. These differences are discussed in relation to the differences in chemical bonding interactions at the surfaces as described by theoretical calculations performed for the cases of Cu, Cr, and Au. Several differences in orbital interactions, as well as a sensitivity to bonding configurations, are illustrated with the aid of extended Hückel calculations on hypothetical organometallic complexes and extended Hückel/tight binding calculations of the interface for parallel versus perpendicular adsorbate orientations.

PACS numbers: 61.30.-v, 68.35.B5, 64.70.Md

I. INTRODUCTION

Since 1970, studies of liquid crystal (LC) surface interactions and alignment have proceeded actively, and several reliable methods of producing structurally inhomogeneous surfaces have been found that are effective in controlling the alignment and orientation of an LC at solid surfaces.¹ Recent studies have shown that variable oblique alignment of a nematic liquid crystal (NLC) can be achieved by the interaction of NLCs, with compositionally and microscopically inhomogeneous but macroscopically homogeneous surfaces.^{2,3} However, in spite of the great effort being devoted to the study of alignment of LCs, the molecular interactions with, and alignment by surfaces remain among the least understood areas of LC physics and chemistry.

The interaction between the LC molecules and the surface could induce orientation order and, hence, affect bulk alignment properties of LC cells. Because alignment schemes usually involve roughening of the surface, it is difficult to separate the geometrical effects due to roughness from bonding interaction effects. In this paper, we will address the role of surface bonding interactions on the alignment properties in the bulk phase by comparative studies of the induced alignment for a NLC, 4'-n-pentyl-4-cyanobiphenyl (5CB, also referred to as PCB and K15) bordered by various flat metal surfaces from both experimental (measurements were made for Cr, Cu, Ag, and Au surfaces) and theoretical (computations were performed for Cr, Cu, and Au) approaches. The results show that chemical bonding is an important factor in the LC's surface alignment.

Figure 1 shows two proposed bonding configurations of a single 5CB molecule on a flat metal surface (for simplicity, the axis of the molecule has been chosen to lie entirely along the parallel or vertical directions, in each case). In

order to gain insight on the chemical origins of preferred surface anchoring configurations, molecular orbital calculations were performed on hypothetical organometallic complexes consisting of a fragment of the 5CB, cyanobenzene, interacting with isolated metal atoms at several bonding locations. Surface anchoring resulting from chemical bonding considerations would most likely involve the 4-cyano-biphenyl moiety of the 5CB molecule, and the hydrocarbon tail is approximated as a noninteracting entity. This is a reasonable approximation, since chromium forms metallocenes such as dibenzenechromium⁴, and Cu, Au, and Ag, form cyanide complexes.⁵ For computational simplicity, the cyanobenzene fragment was used to illustrate the basic bonding features of the full 5CB molecule for each case.

These complexes involving a single metal atom interacting with cyanobenzene are not intended to approximate the chemical bonding activity at a surface. Rather, they form a starting point, from which we can visualize the electronic interactions that drive the actual surface bonding. A more realistic model may be achieved by performing calculations involving a cluster of metal atoms⁶ or by extension of the interface to two dimensions by applying periodic boundary conditions. The latter approach was chosen, and was implemented using the extended Hückel/tight binding method⁷ for a layer of cyanobenzene upon a two-layer slab of the metal. To simplify the calculations, intermolecular interactions were neglected by considering a dilute overlayer. The effects of surface contaminants on the metal films have also been neglected for these studies.

In this paper, we will present the experimental results, discuss the computational results for the molecular orbital calculations and summarize the main features of the 2-dimensional, interface calculations. The simplified molecular

orbital calculations served as a guide to choose the possible bonding geometries for the more realistic interface calculation. Because their interpretation is simple, the molecular orbital calculations serve to illustrate the main features of bonding for the case of Cr, where surface band structure effects are less important than the cases of Cu and Au. We will, therefore, discuss the case of a Cr atom complex with cyanobenzene in full detail. The computational results for Cu will also be discussed. Although Au might be expected to behave similarly to Cu, both the experimental and theoretical findings show major differences. For this case, the differences in surface electronic structure are important, the molecular orbital approximation is inadequate, and the full 2-dimensional surface treatment is required to explain the behavior. In the next section, we first discuss the experimental measurement methods and results. A section on the computational methods follows. Finally, the computational results are discussed in detail in Sec. IV.

II. EXPERIMENTAL METHODS AND RESULTS

Different experimental methods have been used to study the surface induced orientational ordering, such as the induced birefringence,^{8,9} conoscopy method,⁸ magnetinull method,¹⁰ transmission ellipsometric techniques,^{11,12} evanescentwave-ellipsometric techniques,¹³ and optical second-harmonic generation.¹⁴ In this study, we are interested in determining the induced orientational ordering in liquid crystals by smooth metal surfaces. The orientational ordering is either parallel to the surface (which we refer to as parallel orientation) or vertical to the surface (homeotropic orientation, which we refer to as vertical orientation). Therefore, we use the induced birefringence method with consistency verification by the conoscopy method. The construction of the samples is illus-

trated in Figure 2. The flat metal films of Cr, Cu, Ag and Au with thickness of about 1000 Å were either sputtered or evaporated onto Cr-coated silicon wafers. The top cover glass surfaces were coated with silane DMOAP,¹⁵ using the procedure described in reference 3, which aligns the LC vertically to the surface,^{1,16} and were offset from the metal surface by spacers of thickness of about 12 μm. The 5CB was injected into the cells by capillary flow at about 50°C. The major component of the surface alignment ("vertical" or "parallel") was determined by observing the sample in a microscope between cross-polarizers in the reflection mode and checking for the presence or absence of birefringence. Birefringence is absent for the case of vertical alignment, whereas birefringence is induced for parallel alignment. The parallel alignment is further verified by checking the disclination line.⁸ We have also obtained consistent alignment results using the conoscopy image for transparent glass substrates coated with the metal of a thickness less than 100 Å.

Using the three experimental methods described above, we have found that for the nematic 5CB, Ag and Cu produce vertical orientation, whereas Au and Cr produce parallel orientation. Although these experiments have been performed using thick (~100Å) continuous metal films, the results are also in agreement with the respective result for Cr, Cu, Ag, and Au with a thicknesses of less than 100Å, for which then randomly distributed microscopic metal islands are formed³.

III. COMPUTATIONAL METHODS

The semiempirical, extended Hückel linear combination of atomic orbital method^{17,18} was applied, for hypothetical organometallic compounds consisting of

two types of configurations of a single metal atom interaction with cyanobenzene, a fragment of the 5CB. As shown in Fig. 3, two types of bonding configurations were considered. Figure 3(a) shows the metal atom placed above the benzene ring of the cyanobenzene, and Fig. 3(b) shows the metal atom bonded with the cyano group. The carbon ring bond angles and bond distances taken were those of benzene, (C-C, 1.39Å) and (C-H, 1.1Å), the cyanide C-N distance was taken to be 1.15Å, and the cyanide to benzene ring distance was chosen to be 1.5Å. The placement of the metal atom above the benzene ring in Fig. 3(a) was chosen to be 1.6Å, the distance between the Cr atom and arene ring in dibenzenechromium.⁴ The existence of a local minimum for Cr placed above the benzene ring in several arene complexes was verified by Rossi¹⁹ using ab-initio calculations. Three metal to nitrogen bond distances were compared for consistency (1.7Å, 1.85Å, and 2.1Å). Slater type orbitals were used, with two exponential terms for the 3d orbitals (for Cr and Cu) and 5d (for Au) orbitals. The exponents obtained by Clementi²⁰ for the Cr 3d orbitals were used, and the coefficients and remaining parameters were taken from the charge iterated values used by Rossi²¹ for a chromium 3d- π complex with a polyimide fragment.²² The parameters for Cu were obtained from Elian et. al.²³ and the values for Au from Komiya et. al.²⁴ were used.

The interface calculation utilized the extended Hückel/tight binding method for a two layer slab of metal and one adsorbed layer of cyanobenzene. The (111) surfaces of Au and Cu, and the (110) surface of Cr were chosen. For each surface, two bonding configurations for perpendicular alignment were considered, bonding of the nitrogen of the cyano group directly on top of a metal atom, and at a site bridging two metal atoms. The configuration chosen for the parallel orientation positions a metal atom directly below the phenyl ring, analogous to

the metallocene complexes. Dilute overlayers were used for the computations. For Cu and Au (FCC), the unit cell contained sixteen metal atoms and one cyanobenzene molecule. For Cr (BCC), the unit cell contained fifteen metal atoms and one molecule. The key results of the slab calculations for Cr and Cu will be discussed in the following sections to augment the molecular orbital computations and to allow us to interpret our experimental results. The computational details, as well as the full results, are treated in a separate publication.²⁵

IV. COMPUTATIONAL RESULTS AND DISCUSSION

The first consideration is a description of the orbital composition and symmetries of cyanobenzene. The construction of the molecular orbitals for cyanobenzene from the fragment orbitals of CN and benzene is shown in the interaction diagram in Figure 4. The orbitals of cyanobenzene (center) are formed by combining the molecular orbitals of the fragments, CN (left) and benzene (right). The degeneracy of the e_{1g} orbitals of benzene (D_{6h} symmetry) is formally removed by the reduction of the symmetry to C_{2v} to form the a_2 and b_2 orbitals of cyanobenzene. The a_2 and b_2 levels in the central panel in Figure 4 are nonbonding with respect to the CN fragment; they remain essentially unchanged upon combination of the cyanide and benzene fragments. The a_1 orbital of benzene, which is formed from p-orbitals which lie in the plane of the ring, interacts with the uppermost, filled σ -orbital of CN to form the a_1 orbital of cyanobenzene (shown). The E_{2u} antibonding orbitals of benzene split upon combining with the π^* orbital of CN to form the a_2 and b_2 antibonding orbitals of cyanobenzene. The b_2 level is lowered, whereas the a_2 level is not significantly affected. The b_2 level is important because it becomes the characteristic acceptor level of this molecule.

Differences in chemical bonding, and consequently, the LC surface alignment properties, are derived from the differences in the electronic structure of the contrasting surfaces. Contrasting the chemical bonding that occurs for the bonding of single metal atoms (comparing the metals) at different locations is a useful exercise, which gives insight into the surface interactions occurring in the actual experiment, while the differences due to the extended structure of the surface are realized in the slab calculations. The molecular orbital calculation predicts the correct alignment for Cr (parallel) and Cu (perpendicular) but is oversimplified for the case of Au. For Au, parallel alignment is observed, whereas the vertical alignment is predicted by the molecular orbital calculation. The failure of the single metal atom calculation for Au is not surprising, and the correct configuration is, indeed, realized when a more realistic set of surface *electronic wavefunctions* are utilized in the slab calculation.

We first discuss the results of the molecular orbital calculation for Cr in detail, with the aid of an interaction diagram to illustrate the main features of the surface bonding interactions. The extent of bonding that occurs between the symmetry related orbitals for a given configuration depends on both the overlap of the respective wavefunctions and the corresponding energy level separation. Figure 5 compares the relative energy levels of cyanobenzene with the relative ionization energies of the s and d atomic orbitals of Cr, Cu, and Au. Also indicated in Fig. 5 are the populations of the implicated orbitals. Usually, it is the frontier states which are implicated in the reactivity. For Cr, the frontier level of cyanobenzene is within the d-block, whereas the d-blocks of Cu and Au are removed to an energy below the frontier orbitals. For the case of a Cr atom

interaction with cyanobenzene, it was observed that placement above the aromatic ring was energetically preferred over the cyanobenzene bonding location. This geometry results in an interaction similar to that observed in dibenzenechromium and in Cr interaction with polyimide model compounds.²² Figure 6 shows a partial interaction diagram for the case of Cr bonding at the benzene ring. The two lowest lying unoccupied orbitals (a_2 and b_2) of cyanobenzene combine with the occupied d_{xy} and $d_{x^2-y^2}$ levels of Cr to form bonding (shown) and antibonding levels (not shown). The energy levels shown are the relative levels which result from the extended Hückel calculation. By comparison, the case of Cr bonded to the nitrogen of cyanobenzene was found to be essentially noninteracting. The total energy difference for the two configurations was $\sim 3\text{eV}$, favoring the π -bonded configuration. It is noted that the total energies obtained from the extended Hückel method originate from orbital overlap and, therefore, the trends of the relative energies for comparative complexes, rather than absolute energies, are observed in these studies. The strong differences in bonding for the two configurations lead us to believe that a π -bonding interaction of the SCB involving the surface d-band may be the driving force of the experimentally observed parallel induced alignment. The 2-dimensional interface calculation also shows preference for the π -bonded configuration. The d-band of the Cr surface is responsible for this interaction, with the a_2 and b_2 levels of cyanobenzene each being lowered by $\sim 0.4\text{eV}$ due to bonding. By comparison, the perpendicular bonding configuration shows little bonding effect. For this example, the molecular complex picture was representative of the surface bonding because the Cr surface interaction is driven by the d-band of the Cr and, therefore, shows some of the character of $3d-\pi$ bonding observed for the hy-

pothetical complex. For Cu and Au, the surface band character of the metal is more important.

Next, for Cu, the interactions are described similarly, however, the bonding preference is not between the d-states of the metal and the π -system of the aromatic group, as was the case for Cr. Instead, the primary bonding feature is between the orbitals arising from the cyanide fragment. Although a perpendicular bonding preference is observed from both the Cu atom complex and slab computations, the latter method has been found to illustrate subtle differences in the details of the bonding interactions that contribute to the interface bonding. Here, hybrid states comprised of d_{z^2} and s character interact with the a_1 level of the cyanobenzene, which is reminiscent of the 5σ level of the cyanide fragment. A weaker π -interaction occurs between combinations based on d_{xz} and p_x (in the surface plane) orbitals of the metal and the b_2 LUMO.

For Au, the interaction is weak, the surface electronic structure is important, and the molecular orbital calculations do not predict the correct, parallel alignment of cyanobenzene on this surface. The 2-dimensional surface electronic wavefunctions must be used to realistically simulate the interface. Generally, the molecular orbital calculation and the slab calculation converge to the same dominant orbital interactions for strongly interacting species, while major differences occur for weakly bonded interfaces. The extended Hückel/tight binding interface calculations correctly predict parallel alignment for the 5CB on Au. For the discussion of the origins of the alignment behavior for this case, we refer the reader to the full paper on the tight binding calculations.²⁵

From the experimentally observed induced alignment for various flat metal surfaces, we have shown that differences in interfacial chemistry may produce

dramatic effects on anchoring geometries. The origins of the electronic interactions, which are responsible for this behavior, were described by electronic structure calculations and the example of cyanobenzene interaction with Cr, was illustrated with the pictorial aid of an interaction diagram derived from a molecular orbital calculation on an organometallic complex.

ACKNOWLEDGEMENTS

We are grateful to Angelo R. Rossi for many useful discussions during the course of this work. The work at Cornell was supported by the Office of Naval Research.

References

1. For a review, see J. Cognard, *Mol. Cryst. Liq. Cryst. Supp.* **1**, 1 (1983).
2. R. B. Meyer, *Alignment of Liquid Crystals by Inhomogeneous Surfaces*, oral presentation at the 7th International Liquid Crystals Conference, Bordeaux, France, 1978.
3. H. L. Ong, A. J. Hurd, and R. B. Meyer, *J. Appl. Phys.* **57**, 186 (1985).
4. A. Haaland, *Acta Chem. Scand.* **19**, 41 (1965).
5. For a general discussion of nitrile bonding, see M. A. Andrews, C. B. Knobler, and H. D. Kaesz, *J. Am. Chem. Soc.* **101**, 7260 (1979).
6. I. P. Batra and P. S. Bagus, *Solid State Commun.* **16**, 1097 (1975).
7. M.-Whangbo, R. Hoffmann, *J. Am. Chem. Soc.* **100**, 6093 (1978); M.-H. Whangbo, R. Hoffmann, and R. B. Woodward, *Proc. Roy. Soc A366*, 22 (1979).
8. P. G. de Gennes, *The Physics of Liquid Crystals* (Oxford University, Oxford, 1974).
9. G. Baur, V. Wittwer, and D. W. Berreman, *Phys. Lett.* **56A**, 142 (1976); H. Birecki and F. J. Kahn, in *The Physics and Chemistry of Liquid Crystal Devices*, edited by G. J. Sporkel (Plenum, New York, 1980), p. 115.
10. T. J. Scheffer and J. Nehring, *J. Appl. Phys.* **48**, 1783 (1977).
11. K. Miyano, *Phys. Rev. Letts.* **43**, 51 (1979); J. C. Tarczon and K. Miyano, *J. Chem. Phys.* **73**, 1994 (1980).
12. H. A. van Sprang, *J. Phys. (Paris)* **44**, 421 (1983).
13. H. Hsiung, Th. Rasing and Y. R. Shen, *Phys. Rev. Letts.* **57**, 3065 (1986).

14. P. Guyot-Sionnest, H. Hsiung, and Y. R. Shen, *Phys. Rev. Letts.* **57**, 2963 (1986).
15. DMOAP is N, N-dimethyl-N-octadecyl-3-aminopryltrimethoxysilyl chloride. Available from Petrarch Systems, Inc. as silane 09745 and Dow Corning as silane XZ-2230.
16. F. J. Kahn, *Appl. Phys. Letts.* **22**, 386 (1973).
17. R. Hoffmann and W. N. Lopscomb, *J. Chem. Phys.* **36**, 2179 (1962).
18. R. Hoffmann, *J. Chem. Phys.* **39**, 1397 (1963).
19. A. R. Rossi (private communication).
20. E. Clementi and C. Roetti, *At. Nucl. Data Tables* **14**, 122 (1974).
21. A. R. Rossi (private communication).
22. A. R. Rossi, P. N. Sanda, B. D. Silverman, and P. S. Ho, *Organometallics* **6**, 580 (1987).
23. M. Elian, R. Hoffmann, *Inorg. Chem* **14**, 1958 (1975).
24. S. Komiya, T. A. Albright, R. Hoffmann, and J. K. Kochi, *J. Am. Chem. Soc.* **99**, 8440 (1977).
25. S. A. Jansen, R. Hoffmann, P. N. Sanda, D. B. Dove, and H. L. Ong, in preparation.

Figure Captions

Figure 1. Schematic view of a 5CB molecule oriented (a) parallel and (b) perpendicular to the surface of the metal substrate.

Figure 2. Configuration of the cell used for observation of the liquid crystal induced orientational ordering.

Figure 3. Two configurations used for molecular orbital calculations. (a) Metal atom bonded above the phenyl ring of the cyanobenzene, and (b) bonded to the nitrogen of the cyano group.

Figure 4. Interaction diagram showing the orbitals of cyanobenzene (center) and their origins from the orbitals of cyanide (left) and benzene (right).

Figure 5. Relative energy levels of frontier orbitals of cyanobenzene (left) and the d and s orbitals of the metal atoms.

Figure 6. Interaction diagram for a Cr arene complex with cyanobenzene.

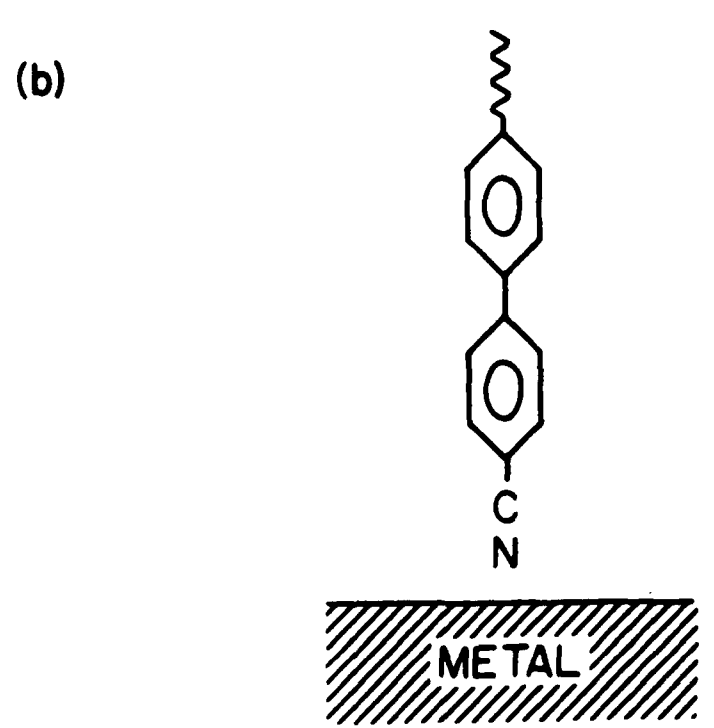
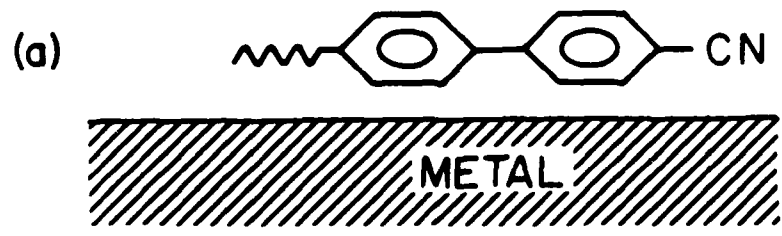

Figure 1

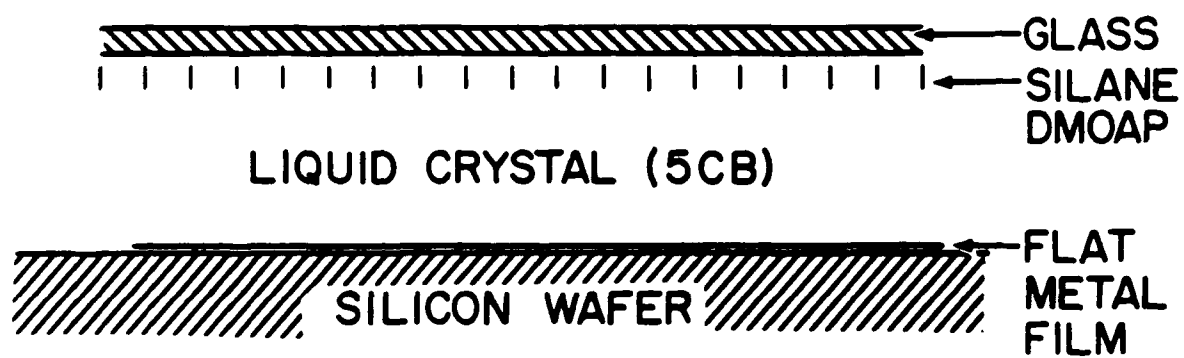

Figure 2

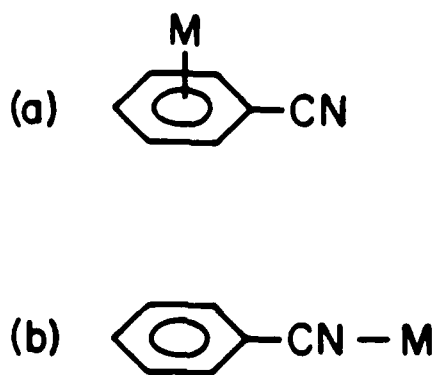

Figure 3

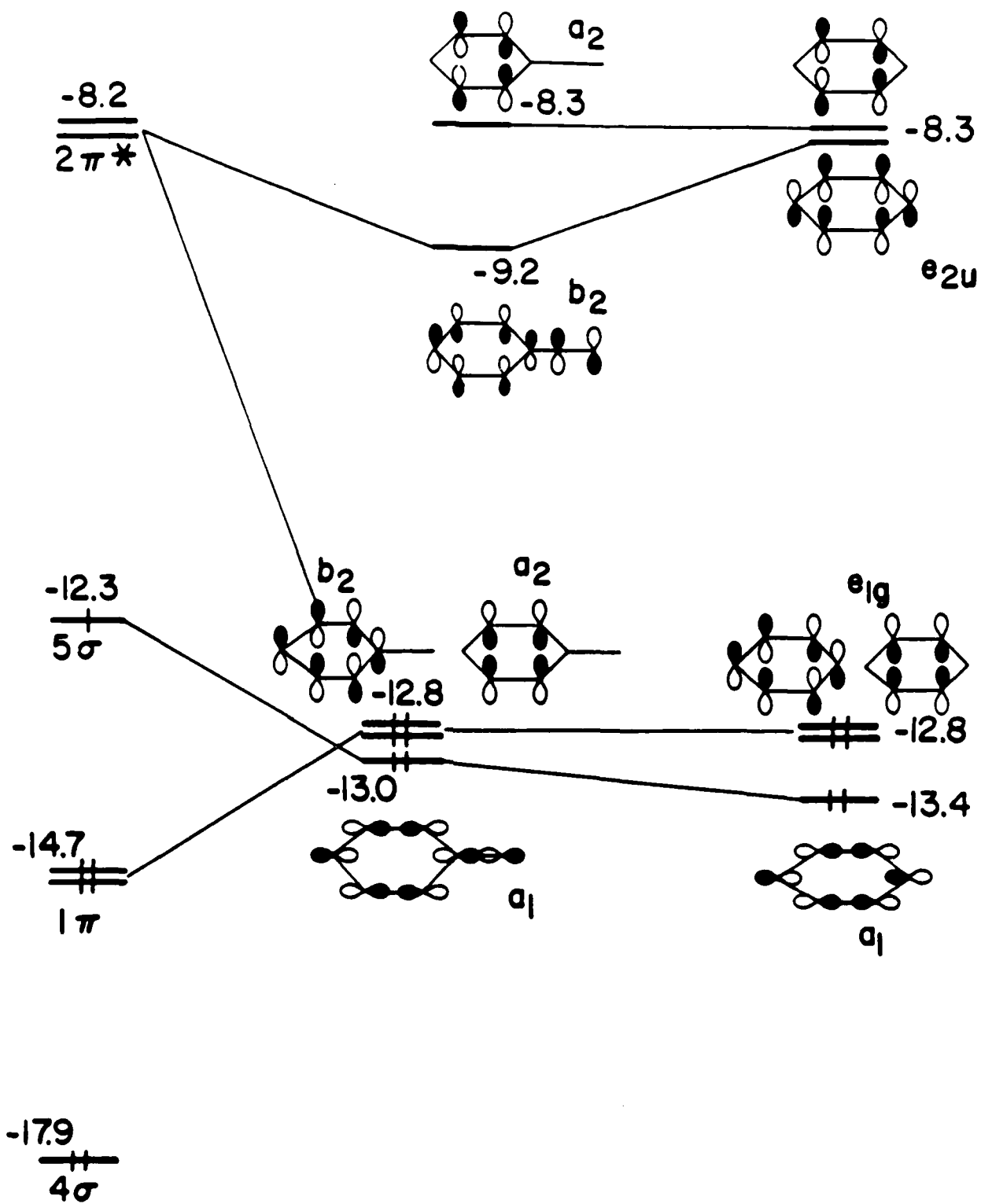

Figure 4

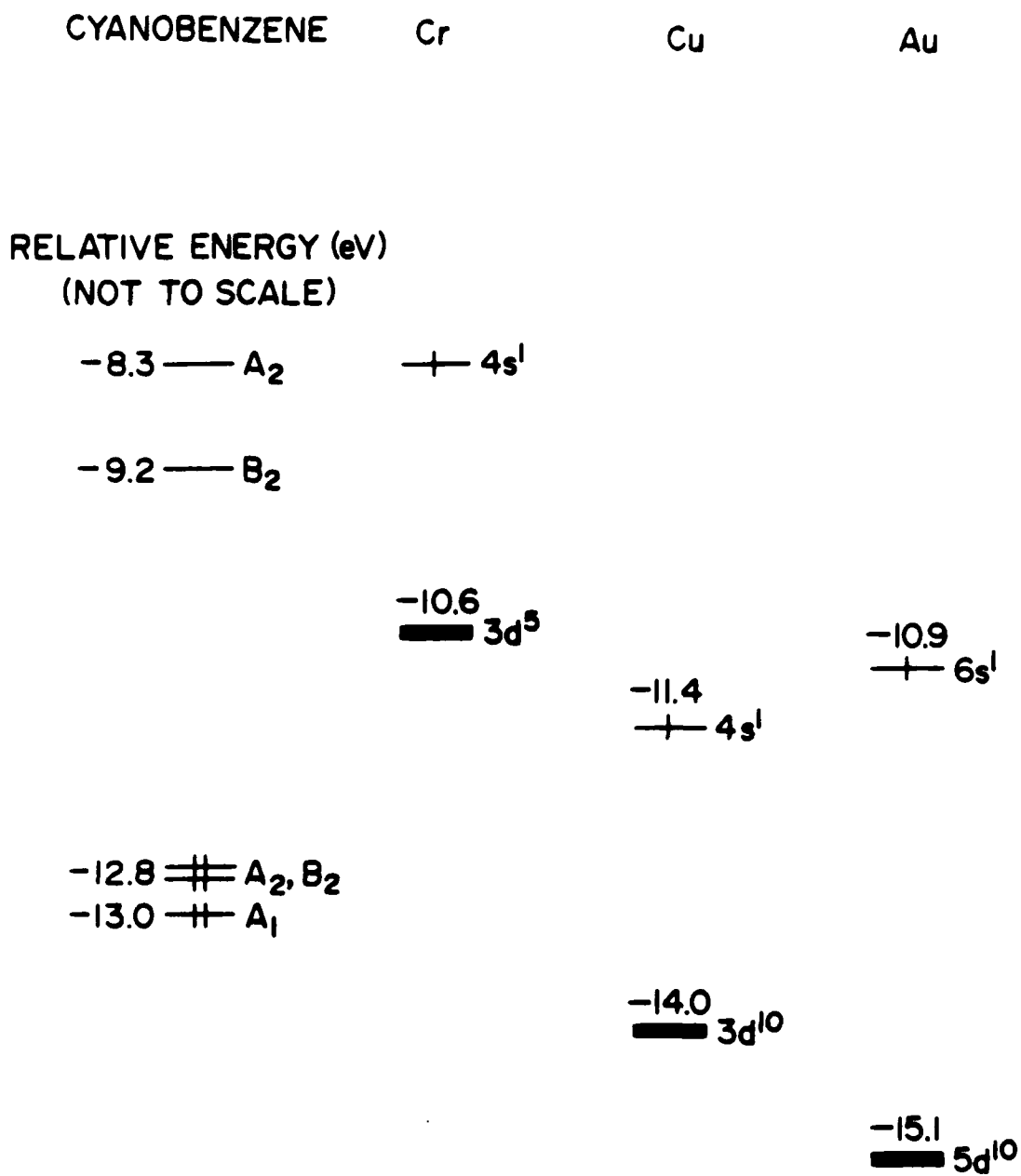

Figure 5

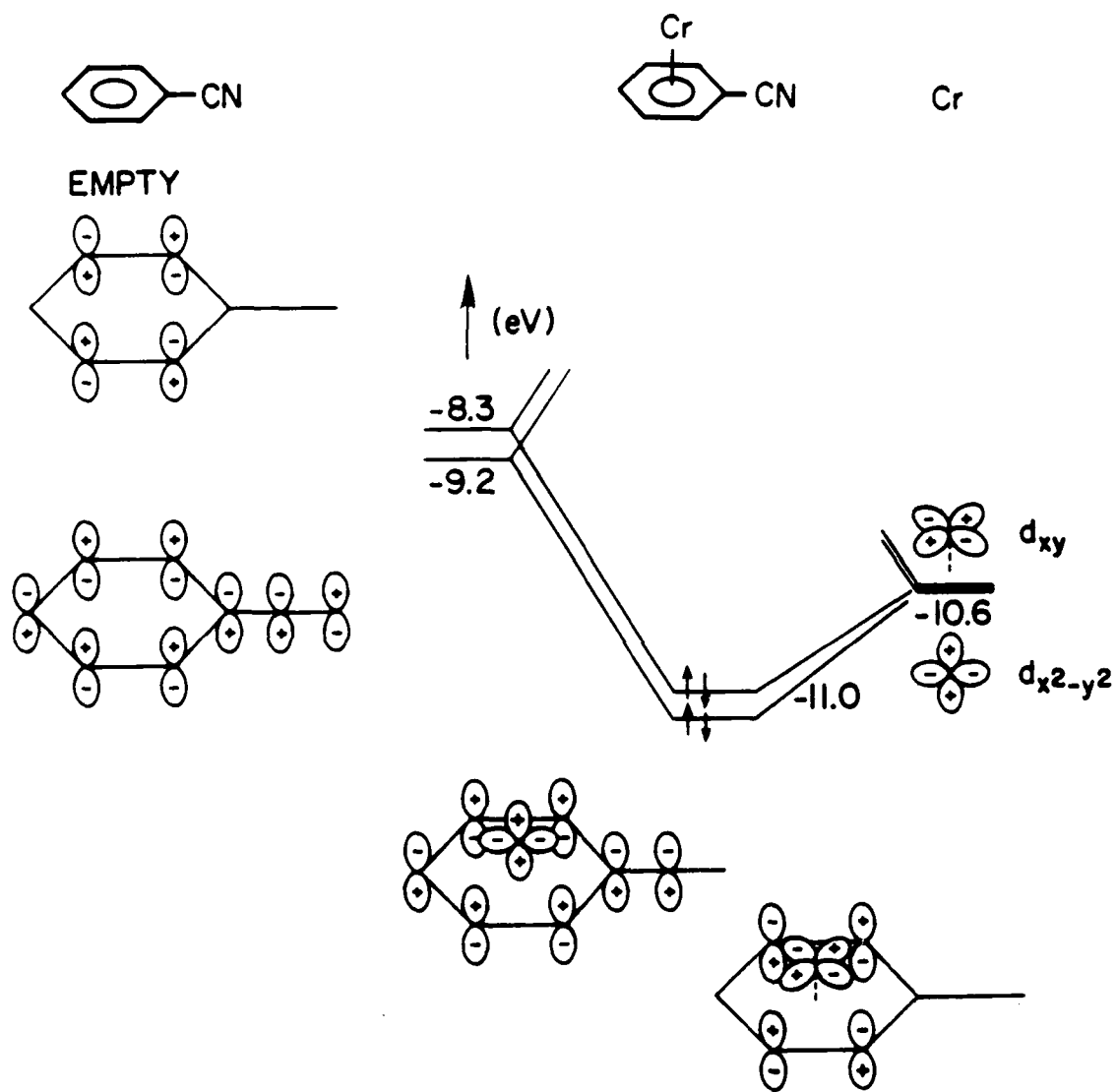

Figure 6

END

DATE

FILMED

DTIC

11-88