

AD-A200 280

NAVAL POSTGRADUATE SCHOOL Monterey, California



S DTIC
ELECTE **D**
NOV 09 1988
D *Cy*

THESIS

INTERCONNECTING DIFFERENT TYPES
OF
LOCAL AREA COMPUTER NETWORKS

by

Daniel C. Malakie

June 1988

Thesis Advisor:

Norman F. Schneidewind

Approved for public release; distribution is unlimited

88 11 08 018

A 20025

REPORT DOCUMENTATION PAGE

| | | | |
|--|--|--|--------------------------------|
| 1a REPORT SECURITY CLASSIFICATION Unclassified | | 1b RESTRICTIVE MARKINGS | |
| 2a SECURITY CLASSIFICATION AUTHORITY | | 3 DISTRIBUTION/AVAILABILITY OF REPORT Approved for public release; Distribution is unlimited | |
| 2b DECLASSIFICATION/DOWNGRADING SCHEDULE | | | |
| 4 PERFORMING ORGANIZATION REPORT NUMBER(S) | | 5 MONITORING ORGANIZATION REPORT NUMBER(S) | |
| 6a NAME OF PERFORMING ORGANIZATION Naval Post Graduate School | 6b OFFICE SYMBOL (if applicable) Code 54 | 7a NAME OF MONITORING ORGANIZATION Naval Post Graduate School | |
| 6c ADDRESS (City, State, and ZIP Code) Monterey, California 93943-5000 | | 7b ADDRESS (City, State, and ZIP Code) Monterey, California 93943-5000 | |
| 8a NAME OF FUNDING/SPONSORING ORGANIZATION | 8b OFFICE SYMBOL (if applicable) | 9 PROCUREMENT INSTRUMENT IDENTIFICATION NUMBER | |
| 8c ADDRESS (City, State, and ZIP Code) | | 10 SOURCE OF FUNDING NUMBERS | |
| | | PROGRAM ELEMENT NO | PROJECT NO |
| | | TASK NO | WORK UNIT ACCESSION NO |
| 11 TITLE (Include Security Classification) INTERCONNECTING DIFFERENT TYPES OF LOCAL AREA COMPUTER NETWORKS | | | |
| 12 PERSONAL AUTHOR(S) Malakie, Daniel C. | | | |
| 13a TYPE OF REPORT Master's Thesis | 13b TIME COVERED FROM _____ TO _____ | 14 DATE OF REPORT (Year, Month, Day) 1988 June | 15 PAGE COUNT 75 |
| 16 SUPPLEMENTARY NOTATION The views expressed in this thesis are those of the author and do not reflect the official policy or position of the Department of Defense or the U.S. Government. | | | |
| 17 COSATI CODES | | 18 SUBJECT TERMS (Continue on reverse if necessary and identify by block number) | |
| FIELD | GROUP | SUB-GROUP | |
| | | Local Area Network | |
| 19 ABSTRACT (Continue on reverse if necessary and identify by block number) When interconnecting local area computer networks of various types there are many issues which the Information Systems manager must consider. This thesis will identify some of these issues as they pertain to the interconnection of four local area computer networks of the Administrative Sciences Department in Ingersoll Hall, Naval Postgraduate School. Relevant information which results from this thesis will be used to enhance this internetting. | | | |
| 20 DISTRIBUTION/AVAILABILITY OF ABSTRACT <input checked="" type="checkbox"/> UNCLASSIFIED/UNLIMITED <input type="checkbox"/> SAME AS RPT <input type="checkbox"/> DTIC USERS | | 21 ABSTRACT SECURITY CLASSIFICATION Unclassified | |
| 22a NAME OF RESPONSIBLE INDIVIDUAL Prof. Norman Schneidewind | | 22b TELEPHONE (Include Area Code) (408) 646-2768 | 22c OFFICE SYMBOL Code 54Ss |

Approved for public release; distribution is unlimited

Interconnecting Different Types
of
Local Area Computer Networks

by

Daniel C. Malakie
Major, United States Army
B.A., State University of New York at Buffalo, 1975
M.A., Boston University, 1980

Submitted in partial fulfillment of the
requirements for the degree of

MASTER OF SCIENCE IN INFORMATION SYSTEMS

from the

NAVAL POSTGRADUATE SCHOOL
June 1988

Author:

Daniel C. Malakie

Daniel C. Malakie

Approved by:

N. F. Schneidewind

N. F. Schneidewind, Thesis Advisor

Y. K. Mortagy

Y. K. Mortagy, Second Reader

David R. Whipple
David R. Whipple, Chairman
Department of Administrative Sciences

James M. Fremgen
James M. Fremgen
Acting Dean of Information and Policy Sciences

ABSTRACT

When interconnecting local area computer networks of various types there are many issues which the Information Systems manager must consider. This thesis will identify some of these issues as they pertain to the interconnection of four local area computer networks of the Administrative Sciences Department in Ingersoll Hall, Naval Postgraduate School. Relevant information which results from this thesis will be used to enhance this internetting.



| | |
|--------------------|-------------------------------------|
| Accession For | |
| NTIS GRA&I | <input checked="" type="checkbox"/> |
| DTIC TAB | <input type="checkbox"/> |
| Unannounced | <input type="checkbox"/> |
| Justification | |
| By | |
| Date | |
| Availability Codes | |
| Dist | Availability Codes |
| A-1 | |

TABLE OF CONTENTS

I. INTRODUCTION.....1

 A. GENERAL.....1

 B. SCOPE OF THE THESIS.....1

 1. Issues.....2

 2. Administrative Sciences Department Labs....2

 3. Approaches for Interconnections.....3

 C. ADDITIONAL CONSIDERATIONS.....3

 1. Compatibility.....3

 2. Government Regulations.....3

 D. ORGANIZATION OF THE THESIS.....4

II. ADMINISTRATIVE SCIENCES DEPARTMENTAL LANS.....5

 A. GENERAL.....5

 1. LAN Definition and Functions.....5

 2. Advantages of LANS.....5

 3. LAN Interconnection Advantages.....6

 B. ADMINISTRATIVE SCIENCES DEPARTMENT
 OBJECTIVES AND APPROACHES.....6

 1. Administrative Sciences Department
 Objectives.....6

 2. Development Approaches.....7

| | | |
|------|---|----|
| III. | PC AND TOKEN-RING NETWORKS..... | 10 |
| | A. GENERAL..... | 10 |
| | B. LABORATORY HARDWARE..... | 11 |
| | 1. PC Lab Hardware..... | 11 |
| | 2. Token-Ring Lab Hardware..... | 13 |
| | C. LABORATORY NETWORK SOFTWARE..... | 15 |
| | 1. PC Lab Software..... | 15 |
| | 2. Token-Ring Lab Software..... | 15 |
| | D. CHARACTERISTICS..... | 16 |
| | 1. PC Network..... | 16 |
| | 2. Token-Ring Network..... | 20 |
| IV. | ENVIRONMENT..... | 22 |
| | A. GENERAL..... | 22 |
| | B. PC NETWORK..... | 23 |
| | 1. Disk Configuration..... | 23 |
| | 2. Batch Files..... | 24 |
| | C. TOKEN-RING NETWORK..... | 25 |
| | 1. Disk Configuration..... | 25 |
| | 2. Batch Files..... | 26 |
| | D. PORTABILITY, PERFORMANCE, USER FRIENDLINESS... | 26 |
| | 1. Environmental and DOS Variables..... | 26 |
| | 2. Performance Considerations..... | 27 |
| | E. NETBIOS..... | 28 |
| | F. MEMORY CONSTRAINTS..... | 28 |

| | | | |
|------|----|---|----|
| | G. | IBM LAN LIMITATIONS..... | 29 |
| V. | | INTERCONNECTION CONSIDERATIONS AND PROTOCOLS..... | 30 |
| | A. | GENERAL..... | 30 |
| | B. | MAJOR DIFFERENCES BETWEEN NETWORKS..... | 30 |
| | | 1. Management..... | 30 |
| | | 2. Transmission Media and Type..... | 30 |
| | | 3. Speed..... | 31 |
| | | 4. Frame Format..... | 31 |
| | | 5. Buffer Parameters..... | 32 |
| | C. | GATEWAYS AND BRIDGES..... | 33 |
| | | 1. Interconnecting LANs..... | 33 |
| | | 2. Bridges/Repeaters..... | 34 |
| | | 3. Gateways..... | 34 |
| VI. | | IMPLEMENTATION..... | 36 |
| | A. | GENERAL..... | 36 |
| | | 1. Interconnection Gateway Hardware Plan..... | 36 |
| | B. | SOFTWARE DESIGN..... | 37 |
| | | 1. Interconnection and Network Programs..... | 37 |
| | | 2. Network Relationships..... | 37 |
| | | 3. Interconnection Specifications..... | 38 |
| VII. | | APPLETALK AND ETHERNET NETWORKS..... | 42 |
| | A. | GENERAL..... | 42 |

| | | |
|-------|--|----|
| B. | LABORATORY HARDWARE..... | 42 |
| 1. | AppleTalk Hardware..... | 42 |
| 2. | 3Com Ethernet Hardware..... | 44 |
| C. | NETWORK CHARACTERISTICS..... | 45 |
| 1. | AppleTalk Network..... | 45 |
| 2. | 3Com Ethernet Network..... | 46 |
| VIII. | PROTOCOLS AND STANDARDS..... | 48 |
| A. | COMPATIBILITY CONSIDERATIONS..... | 48 |
| B. | DoD REGULATIONS..... | 49 |
| C. | COMPATIBILITY PROBLEMS..... | 49 |
| IX. | SUMMARY..... | 51 |
| A. | GENERAL..... | 51 |
| B. | NETWORK SELECTION..... | 53 |
| C. | TECHNICAL CHALLENGES..... | 54 |
| D. | USER INTERFACE AND PERFORMANCE..... | 56 |
| E. | CONCLUSION..... | 56 |
| | APPENDIX A (Examples of Batch Files)..... | 58 |
| | APPENDIX B (Examples of LOTUS Batch File)..... | 63 |
| | LIST OF REFERENCES..... | 64 |
| | INITIAL DISTRIBUTION LIST..... | 66 |

LIST OF FIGURES

| | | |
|----|---|----|
| 1. | IBM PC Network Hardware..... | 12 |
| 2. | IBM Token-Ring Multiple Access Unit..... | 14 |
| 3. | LAN Topologies..... | 16 |
| 4. | ISO OSI Layers..... | 19 |
| 5. | PC Network Server Disk Configuration..... | 23 |
| 6. | Examples of Packets/Frames..... | 32 |
| 7. | Gateway..... | 35 |
| 8. | AppleTalk Network Connection Example..... | 43 |

I. INTRODUCTION

A. GENERAL

The number of computer Local Area Networks (LANs) are increasing rapidly, and this trend is expected to continue. These networks display a variety of differences among themselves, such as transmission speeds, protocols and standards. A problem, presently in the making, is connecting these networks.

Interconnecting different types of local area networks is an exciting, challenging concept. This thesis will study the interconnection problem and outline an approach which may be used by various installations to resolve the problem. The thesis will discuss the various local area networks utilized by the Administrative Sciences Department of the Naval Postgraduate School.

B. SCOPE OF THE THESIS

This thesis will cover the issues associated with LAN interconnection processes, introduce the Administrative Sciences Department networks, the approaches taken for the interconnection of departmental LANs and other numerous, relevant and pertinent issues.

1. Issues

Since the types of computer networks and resources in the Administrative Sciences Department differ, a number of issues must be considered:

- What hardware is necessary to interconnect different LANs and how should it be configured? Will it allow for flexibility in changing configurations?
- How can differences in transmission types be resolved (broadband vs. baseband)?
- What network and internetwork software is necessary and how should it be configured?
- Can networks utilizing different transmission management techniques communicate to each other and if so, what is required?
- How will the interconnection of LANs affect their performance and are there any advantages from interconnecting LANs?
- What effect do protocols have on interconnection strategies?

2. Administrative Sciences Department Labs

Specific approaches and developmental processes will be covered concerning the four types of networks in the Administrative Sciences Department. These networks include:

- IBM Personal Computer (PC) Network
- IBM Token-Ring Network
- AppleTalk Network
- 3Com Ethernet Network

The development process, composition and operating environment will be covered for each network and their interconnection to another network.

3. Approaches for Interconnections

Different approach methods will be considered for performing the interconnections:

- What should the user interface consist of? How do you make the system user friendly?
- What can be done to improve efficiency in the networks/interconnect with the equipment on hand?
- Can transparency be achieved in networks given the constraints?
- How much protocol conversion should be done and what should be the functions of the interconnect?

C. ADDITIONAL CONSIDERATIONS

1. Compatibility

There are numerous hardware and software vendors that produce products that are often of different standards, architecture and protocols. As a result of this, interconnecting different types of equipment can become extremely complex. This thesis will identify and discuss numerous difficulties which were experienced in the actual development and implementation of interconnecting microcomputer networks while working on this thesis.

2. Government Regulations

In addition to the difficulty experienced in compatibility problems, unlike civilian industry, the Department of Defense (DoD) is in a unique position. There are numerous government regulations that pertain to automatic

data processing (ADP) which compounded compatibility problems and restricted equipment procurements. Some of these issues will briefly be discussed in this thesis.

D. ORGANIZATION OF THE THESIS

An introduction to the Administrative Sciences Departmental LANs, their advantages and objectives will be discussed in Chapters II and III. Two of the LAN operating environments will be covered in Chapter IV, to include characteristics, such as disk configuration, user interface and performance considerations. Chapters V and VI will consider the interconnection issues involved in internetting different types of LANs. This will include management, transmission media, transmission types and other pertinent considerations. Chapter VII will briefly discuss two other departmental LANs and future plans concerning them. Protocol standards and government regulations will be discussed in Chapter VIII. Lastly, Chapter IX will summarize what this thesis covered and some of the difficulties encountered in the actual implementation of interconnecting different types of microcomputer LANs.

II. ADMINISTRATIVE SCIENCES DEPARTMENTAL LANS

A. GENERAL

This chapter will describe what a LAN is and what advantages are gained by installing LANs and interconnecting them. It will also consider the objectives of the Administrative Sciences Department with regard to LANs.

1. LAN Definition and Functions

According to the IEEE 802 Committee:

A Local Network is a data communication system which allows a number of independent devices to communicate with each other. [Ref. 1:p. 3]

This communication network is usually in a small geographic area (usually up to 10 km maximum) and allows for high speed data exchange (up to 10 million bits per second (Mbs) for most LANs)

2. Advantages of LANs

There are numerous advantages in the use of LANs:

- Expensive resources can be shared, such as disks and printers.
- Maintenance is simple since there is one centralized copy of software programs.
- Since there is only one copy of software for the network, it is less expensive than providing one for each machine.
- PCs can communicate and transfer data to each other.
- A network can link to larger computers and share their resources.

3. LAN Interconnection Advantages

There are a number of advantages in interconnecting LANs. The original advantages gained from constructing a LAN also relate to interconnecting LANs. In addition to these, there are numerous more specific advantages gained in interconnecting.

- The physical distance could be increased by interconnecting two LANs. Devices from each LAN could communicate the entire length of their own LAN and the other LAN.
- Devices utilizing one physical transmission type, i.e., broadband, could communicate with devices utilizing another type, i.e., baseband.
- Devices utilizing one message format/packet could communicate with devices using another type.
- Devices on one network could be addressed by devices on another network.

B. ADMINISTRATIVE SCIENCES DEPARTMENT OBJECTIVES/APPROACHES

1. Administrative Sciences Department Objectives

The primary objective of installing and interconnecting LANs in the Administrative Sciences Department was two-fold:

- For educational purposes, to present students different types of LANs for exposure, comparison and practical experience.
- To allow for resource sharing, such as printers, disks and software, while offering these resources for utilization and instructional tools.

2. Development Approaches

a. User Interface

There are three types of users that utilize the Administrative Sciences microcomputer labs. These users are novice, knowledgeable intermittent and frequent user. Of these users each has a different purpose or intent for utilizing the labs. It is important to understand these differences:

Every step in understanding the users and in recognizing them as individuals whose outlook is different from the designers own is likely to be a step closer to a successful design. For example, a generic separation into novice, knowledgeable intermittent and frequent users might lead to different design goals. [Ref. 2:p. 52]

(1) Users.

- Novice--is not familiar with computers or application programs.
- Knowledgeable intermittent--familiar with computers but not specific programs.
- Frequent users--familiar with computers and applications.

(2) User Purposes.

- Computer is used as a tool to accomplish a task.
- Computer and LANs are studied and used as a learning experience/learning tool.
- Computer and LANs are used in advanced LAN research.

In developing a LAN and internetting LANs, all of these factors must be considered. The user interface must be friendly, flexible and allow for each type of user and user purpose.

b. Network/Internetwork Performance

The development of LANs in the Administrative Sciences Department has occurred recently. There was a specific priority in the development of LAN operation and user interface.

- Initial set up and basic operation.
- Develop a more user friendly system.
- Fine tune performance of the system.
- Make the system portable and easy to perform maintenance on.

The development of the Token-Ring and PC network interconnection incorporate all of these four phases. Further thesis work may be done concerning the internetting of the AppleTalk and 3Com Ethernet networks.

c. Protocol Conversion/Interconnect Functions

Decisions regarding these interconnection issues must be made before, not after, the networks are implemented. [Ref. 3:p. 3]

The decision to implement an IBM system interconnection between the IBM Token-Ring and IBM PC networks allowed for a well-documented, simple and easy to implement interconnection. An interconnection has been implemented and is operational using a small, experimental system between these two networks. The ease of installation, limited compatibility problems and increased reliability was obtained by using all IBM LAN and interconnection products. Protocol conversions were simplified by utilizing this method. The overall objective of demonstrating an

interconnection between these LANs was accomplished. However, by utilizing an interconnection such as this, the internet functions are rather limited, i.e., no file transfer protocol is provided.

III. PC AND TOKEN-RING NETWORKS

A. GENERAL

The Administrative Sciences Department has an IBM Personal Computer (PC) network laboratory and an IBM Token-Ring network laboratory. Both of these laboratories have user and server computers. The server computer shares its resources, such as disks and printers, and the user computers requests use of them. This allows for shared use of expensive items, such as laser printers and also shared use of software. It further facilitates ease of software maintenance since only one copy of software is required for the network. Any upgrading or changes to this software may be done in one location and only need to be done once for the entire network. Both networks also allow for message transmission between user computers. This chapter will provide a detailed description of both laboratories' hardware and software. It will also consider their logical and physical topologies and management types. The differences between transmission mediums and types will be identified and discussed. Interconnection issues will be directly related to the network differences discussed in this chapter.

B. LABORATORY HARDWARE

1. PC Lab Hardware

The PC network consists of four IBM AT server computers and 25 user computers. The server computers each have a 30 megabyte (Mb) hard disk which allows for ample storage of network programs and application software. They also have 1Mb of random access memory (RAM), some of which is addressed above 640 kilobyte (Kb) and utilized for virtual disks. The user computers have 640 Kb of RAM and no hard disks. Some of these are configured with 1200 baud modems which allow for asynchronous dial up communications and some have math coprocessors installed. There is an IBM PC network adapter board in each computer.

Each computer is physically linked to the network by coaxial cable which is attached to the network adapter board. The cables from 24 of the user computers are connected to three eight-way splitter units. Each of these cables can be from 10 to 200 feet long. Each eight-way splitter is connected to the base expander by a short distance kit as seen in Figure 1. The short distance kit provides a one-foot cable; if further distance must be covered there are medium (400-foot cable) and long (800-foot cable) distance kits. All cables come in predetermined lengths (25, 50, 100 and 200 feet). Each length is constructed for a specific signal

strength and characteristic; consequently, you cannot cut the cable to any desired length.

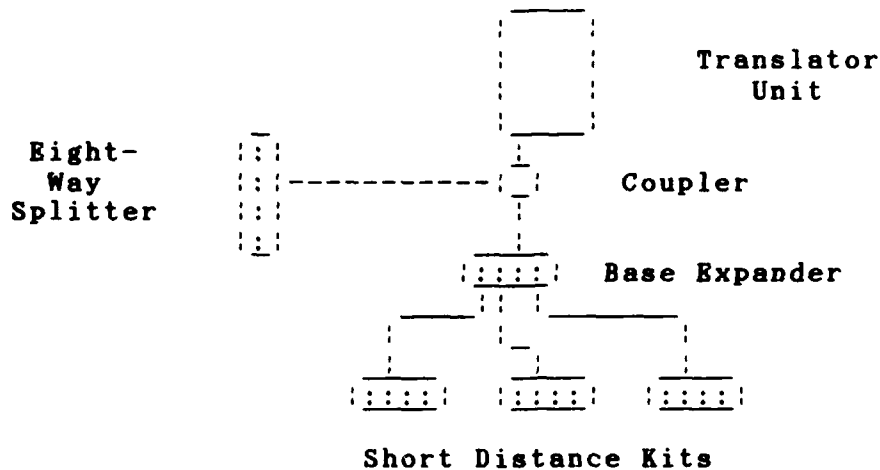

Figure 1. IBM PC Network Hardware

The base expander is connected to a directional coupler, which is connected to a translator connection eight-way splitter. The server computers and one user computer are connected to this eight-way splitter. The directional coupler is then connected to a translator. The translator unit distinguishes between transmissions and reception [Ref 4:p. 334]. There is only a single cable system so two frequencies are used. The translator listens to everything the PCs transmit on one channel (50.75 megahertz, (MHz)) and repeats it on the receive channel (219 MHz) so that every PC on the network can hear it [Ref. 5:p. B-7]. The translator is connected to a low voltage transformer which regulates the power from standard commercial power.

2. Token-Ring Lab Hardware

The Token-Ring network consists of two server computers and 15 user computers. There is an IBM AT server computer used for most of the network and application programs. It has 1 Mb of RAM and a 20 Mb hard disk. It has also been configured with a 3270 emulation board to act as a gateway for synchronous mainframe communication. The user computers consist of three IBM XTs with 640 Kb of RAM, a 20 Mb hard card, a turbo-accelerator board and 12 AT clone computers with 640 Kb of RAM and a 20 Mb hard card. Six of the user computers have 2400 baud modems for asynchronous dial up communication. Some of them also are configured with math coprocessors. Each computer contains a IBM Token-Ring network adapter board. Since each user computer has a hard card or disk, this allows for ease of program storage and execution in stand alone operation. Some application programs require such a large amount of memory that it is not possible to put them on the network because of memory limitation caused by use of network programs. Consequently, these large programs may be loaded on the hard card or disk.

Each computer is physically linked to the network by data-grade twisted pair cable that is enclosed in a black plastic tube. One end of the cable is connected to the adapter board by a D9 connector. The other end of the cable

is connected to an IBM 8228 multiple station access unit (MAU) by a plug with two pairs of solid copper conductors. A type-1 patch cable can be used if additional cable is needed. These cables come in various lengths (8, 30, 75 and 150 feet). A combination of these can be connected together to allow for the appropriate length needed.

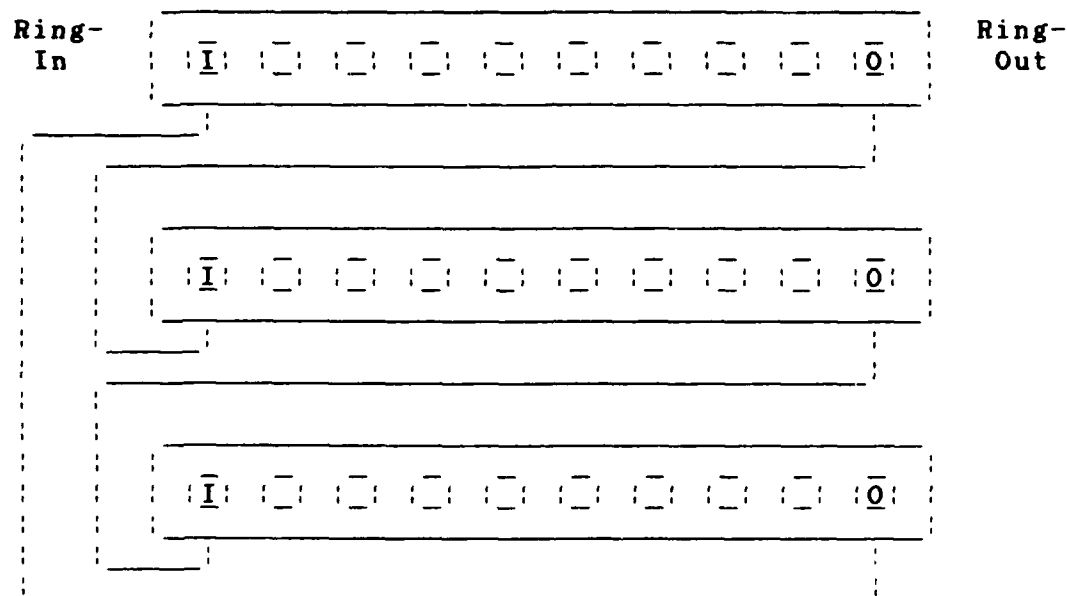

Figure 2. IBM Token-Ring Multiple Access Unit

Each MAU has eight PC connectors and a ring-out and ring-in connector as seen in Figure 2. The MAUs are connected together by attaching a patch cable from the ring-out connector of one to the ring-in connector of another. To allow for a redundancy and additional reliability, a connection has been made from the ring-out connector of the last MAU to the ring-in connector of the first. This

connection is not necessary, but it forms a ring which will allow for most of the network to function if there was a problem/failure in one MAU. A total of three MAUs were used in the network. When a PC transmits an electrical signal, it transmits data on one pair of the four wires in the data grade cable and receives data from the other pair. The data is transmitting in one direction around the ring so that every PC on the ring can hear it.

C. LABORATORY NETWORK SOFTWARE

1. PC Lab Software

The PC net "operating system" software is the IBM PC Local Area Network (LAN) Version 1.1. This works with Disk Operating System (DOS) 3.10 or later and the adapter board in each computer. There are a number of different functions that the network may be configured to in utilizing this software. These will be discussed in the next chapter.

2. Token-Ring Lab Software

The Token-Ring network uses DOS 3.20 or later and the same PC LAN software but also includes two additional programs. These two additional programs are TOKREUI, which is for token management and NETBEUI, which is used for network interface.

D. CHARACTERISTICS

A number of characteristics are used to describe a network. These include topology, transmission media and management.

1. PC Network

a. Topology

The PC network is connected in a physical star/ logical bus topology. The computers are physically connected in a star cluster of eight to a central hub (eight-way splitter), i.e., Figure 3a. These hubs are then connected to the base expander. The bus is logically formed when a common communication medium (coaxial cable) is used to which all network computers are connected, i.e., Figure 3c. When a computer transmits, it is able to send a signal the full length of the bus and it has only one connection onto the cable. All computers on the bus are able to hear all transmissions. This is a very simple topology to implement and allows for reliable communication.

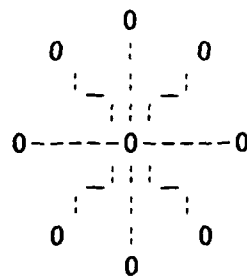

3a. Star

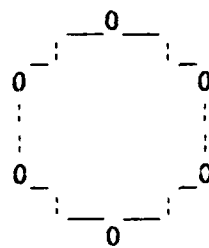

3b. Ring

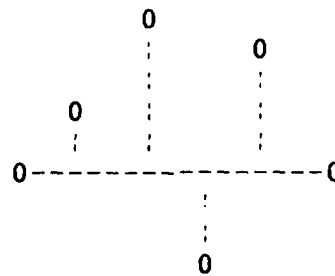

3c. Bus

Figure 3. LAN Topologies

b. Transmission Media

A broadband coaxial cable system was chosen for the PC lab. Coaxial cable (cable television type--CATV) allows for high speed data transmission. It is more reliable and has greater signal response than some types of other media, such as twisted pair wire. The broadband system transmits data by a modulated signal. One major advantage of broadband is that it allows many channels of information to be sent over a single medium. Broadband can also span greater distances (with use of the long distance kits and repeaters) than baseband.

c. Management

The PC network is managed by Carrier Sense Multiple Access/Collision Detection (CSMA/CD) protocol. Because the PC network utilizes a CSMA/CD bus system, collisions are possible if more than one device transmits simultaneously. In this access strategy the computers that share the bus/cable listen before they transmit to see if it is in use. Due to the signal propagation delay, a computer cannot insure that no other computer is simultaneously transmitting; consequently collisions can occur. If a collision is detected, a jam signal is transmitted so that all other computers will abort their transmissions. The computers that are affected then reschedule their next attempt to transmit at different random times. This system

performs well at low to medium loads but is severely degraded at high loads. Because of this, even though the network of 25 user computers can use only one server, four servers were used for improved performance and print service considerations. Performance speed was not the main consideration in choosing this network but rather reliable operation. Transmission speed is approximately 2 Mb per second which is rather slow in comparison with other networks, such as the Token-Ring, with a transmission speed of approximately 4 Mb per second.

This network utilizes a CSMA/CD management system on a broadband bus. This type of management system is covered in the Institute of Electrical and Electronics Engineers (IEEE) 802.3 standard. This standard utilizes the International Standards Organization (ISO) Open System Interconnection (OSI) model. Since communications between computers is so complex, the functional means of communicating have been subdivided into layers. By doing this, electrical and technical constraints can better be managed. There are seven basic layers in this model as seen in Figure 4.

| LEVEL | SCOPE | FUNCTION |
|-------|--------------|--|
| 7 | APPLICATION | APPLICATION FUNCTIONS |
| 6 | PRESENTATION | FORMATTING AND PRESENTING DATA BETWEEN THE NETWORK AND THE USERS |
| 5 | SESSION | OPENING, CLOSING AND MANAGING SESSIONS |
| 4 | TRANSPORT | RELIABLE END-TO-END COMMUNICATION |
| 3 | NETWORK | ADDRESSING AND ROUTING OF PACKETS |
| 2 | DATA LINK | PACKET TRANSFER BETWEEN NODES |
| 1 | PHYSICAL | ELECTRICAL SIGNAL TRANSMISSION |

Figure 4. ISO OSI Layers

The 802.3 standard considers the Physical and Data Link layers. The Physical layer concerns the physical/electrical data signals between computers and the management of the physical medium on which the computers are attached. The Data Link layer is subdivided into the Media Access Control (MAC) which includes various services, access methods and frame structure and the Logical Link Control (LLC) which organizes data flow, handles error and recovery procedures and control signal interchange and responses. The understanding of these functional layers, specific standards and protocols become increasingly important when considering interconnecting different type networks.

2. Token-Ring Network

a. Topology

The Token-Ring network is connected in a physical star-ring/logical-ring, i.e., Figure 3a,b. The computers are physically connected in a star cluster of eight to a central MAU. These MAUs are then interconnected in series and the last MAU is connected back to the first to form a ring. The logical ring is formed through the interconnection of the MAUs and the electrical path between all computers which forms a ring. Data flows around the ring in one direction. Computers connected to the ring can receive and send data from it. It is also easy to add or delete computers from the ring.

b. Transmission Media

A baseband data-grade twisted pair cable was chosen for the Token-Ring network. The twisted pair cable was relatively inexpensive and in a classroom environment, relatively easy to install. It allows for easy connection and disconnection of computers and its signal retention and transmission capability are superior to regular twisted pair wire or telephone wire. The baseband system utilizes a simple two-level encoding where the signals represent either a 0 or 1 and does not require modulation.

c. Management

As the name indicates, the Token-Ring network uses a token passing access management system. When a computer wants to transmit, it must first gain access to the rotating token. Only one token rotates at a time so only one computer can transmit at a time. When the receiving computer gains access to the token, it changes one bit of the packet from free to busy and then transmits. Protocols are inherent in the system to keep each computer from hogging the token. The token is released upon one rotation around the ring and the busy bit is changed back to free. Successful transmission is guaranteed since no collisions may occur, as in CSMA/CD management. As a result of this, the system operates very well at medium to high loads. There are extensive token management procedures needed in this system. It is not very efficient to use this system in an environment where only low to medium loads are expected. Also, if the ring is broken the system will fail. Consequently, redundancy as seen in the "ringing" of the MAUs, is desirable.

This system is covered in the IEEE 802.5 standard. The Physical layer forms an electrical ring for data transmission. The MAC layer prefixes and structures the frame and provides services to the Logical Link Control and Network Management. The Logical Link Control and Network Management control data transmission and token management.

IV. ENVIRONMENT

A. GENERAL

Both the PC network and Token-Ring network use the IBM PC LAN version 1.1. Each computer in the network assumes one of four different types of functions [Ref. 4:p. 25]. First, a computer can be configured to redirect messages. With this configuration it can use network disks, directories and printers offered by others, but cannot receive messages. Second, a computer can be designated as a receiver which can do everything a redirector can do but also can receive messages and save incoming messages in a log file. None of the computers in the Administrative Sciences labs are configured in these two configurations. Third, a computer can be designated as messenger which can do everything mentioned in the first two configurations and also forward incoming messages and adopt additional names to receive messages. Fourth, a computer can be configured as a server which in addition to everything mentioned in the first three configuration, it can also share disks, directories and printers. All configurations have the ability to send messages. The computers in the Administrative Sciences labs are configured as messengers and servers. One disadvantage

of this is that additional memory is required with the increased capabilities acquired.

B. PC NETWORK

1. Disk Configuration

The server computers in the PC network have two floppy disk drives, A and B, and have a hard drive, C as seen in Figure 5. They have also been configured with virtual disks D and E. A major advantage of configuring them with virtual disks is the increased speed that can be gained by not having any mechanical movement time involved in data access (seek time), such as in a typical disk access.

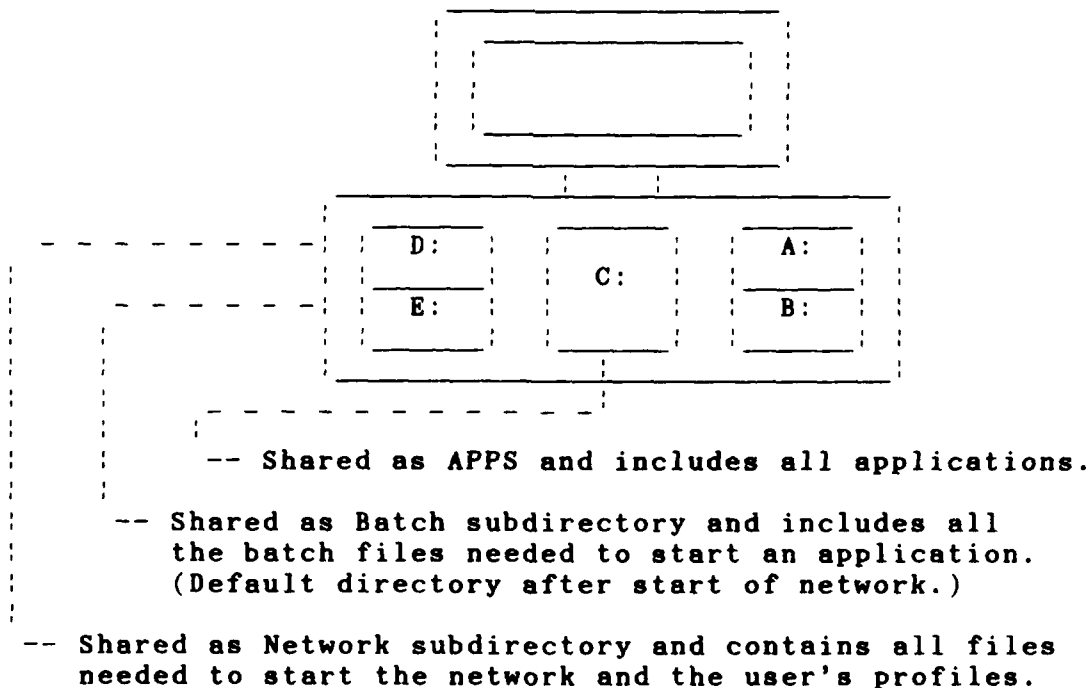

Figure 5. PC Network Server Disk Configuration

Network programs, batch files and application software have been installed on the hard disk (C) of the server. When the server is started, it copies the network programs and batch files from the C disk into the D and E virtual drives respectively. Data exchange between server and user is greatly accelerated by the use of the two virtual disks. The user requests use of the programs on these disks and then can copy them to his computer. The batch files request use of all servers and in case of a server failure, the user will then still have access to the other three servers resources. Users start the network from their A disk utilizing a floppy disk containing an auto-executive and start batch file.

2. Batch Files

A batch file is a small, executable program. A number of these files have been written for network operations. The server has a batch file that starts the network with specific parameters, such as the number of users, print buffer size, etc. Here the server offers to share its resources and sets parameter such as read, write and create for the user. The network programs and program batch files are then copied into the servers virtual disks D and E respectively. Paths to the disk operating system (DOS) and the network programs are set so that the computer knows where to find these programs. The auto-exec and start batch

files of the user allow the user to start the network and configure system parameters, such as user name, printer buffer size, etc. It also requests use of server resources. A unique logical/pseudo name has been given to the applications (APPS) subdirectory of each of the four servers (K, L, M, N). Since these subdirectories are identical and all have the same name (C:\APPS), by creating logical names the user computer can differentiate between the various servers. The user requests use of all servers APPS subdirectory. If a failure of a server occurs, the program will default to another server. This feature greatly increases the reliability of the network. Other batch files are also used for other system configuration parameters, such as the number of files and buffer size, etc. All of these files operate in conjunction with the PC LAN program and DOS.

C. TOKEN-RING NETWORK

1. Disk Configuration

The Token-Ring network operates in a similar fashion as the PC network with the primary difference being the way the network is started. Since the computers in this network all have hard card/disks, the network can be started from the users C disk (hard card). Therefore, no start-up floppy disk is necessary. Other differences in this network are that there is only one server and disks A, B, C, and E are

utilized. Disks A and B are floppy disk drives. Disk C contains network programs, batch files and application programs. Upon network start-up, the server copies batch files from the C disk into virtual disk E and mainframe emulation programs into memory.

2. Batch Files

The user interfaces with the server in a similar method as in the PC network. Batch files have been written to allow for ease of program execution and network usage. A major difference is that not only do these programs interface with DOS and PC LAN programs, but also with the two additional Token-Ring programs (NETBEUI and TOKREUI).

D. PORTABILITY, PERFORMANCE AND USER FRIENDLINESS

1. Environmental and DOS Variables

Development of the batch files which start the network was a challenging task. Initial development effort was to make the network operational, but user friendly. An example of this was to use a DOS variable in the network start files to allow the user to insert a name of his own choice which would also address a header page in this name when using the printer. Further development efforts were to make a portable system to work on both networks with only minor changes (this would greatly improve administrative and maintenance work). Environmental variables were used to

configure this system. These variables were linked to a profile batch file. This profile batch file is configured according to what devices are in each network. These variables encompassed numerous different types of devices or environments.

a. Network Environmental and DOS Variables

- Machine name in the user configuration.
- Network print server name in the user configuration.

b. Hardware Environmental and DOS Variables

- If a machine has a hard disk/card or not.
- If a machine has a modem and what baud rate it is.
- If a machine has a math coprocessor.
- The number of printers attached to a machine.
- If a machine has a color monitor or not.

c. Software Environmental and DOS Variables

- Default paths to DOS and network program.
- Means to locate the COMMAND.COM file.

Examples of a profile batch file and other batch files utilizing environmental and DOS variables can be found in Appendix A.

2. Performance Considerations

Performance was hindered somewhat by the amount of time that is necessary to run the start-up for the network. However, overall performance was improved by limiting the amount of keystrokes the user must enter in and only pertinent files will be loaded by the user machine. An example of this is when a user requests a communications program. If the user machine is not configured with a modem, the start-up

program will recognize the user machine does not have a modem (from the profile batch file). It provides a message to the user that this machine does not have a modem. Consequently, programs from the communications subdirectory will not be loaded from the server. This improves performance by saving time from loading files that are not needed by the user machines. It also improves memory capacity by not taking up additional space in the user machines' memory with these unnecessary files.

E. NETBIOS

The NETBIOS interface is the network control system used by the PC LAN program to implement the network. It provides for transfer of data between the network and the computers in the network. It also manages communication and provides services, such as packet formation. This works in conjunction with the network adapter card that controls the actual physical transfer of data to and from the computer. The NETBIOS translates application program messages so that the adapter support interface can understand them.

F. MEMORY CONSTRAINTS

A large amount of memory will be needed by computers on the network because of network programs, DOS and the manner in which the computers are configured (messenger or server). There are a number of different options for configuration as

mentioned earlier. The messenger configuration requires at least 256 Kb of memory and the server at least 320 Kb of memory. The NETBIOS programs (NETBEUI and TOKREUI) that run in conjunction with the PC LAN programs requires an additional 53 Kb of memory. Also, lDIR, a directory program, requires another 49 Kb.

G. IBM LAN LIMITATIONS

The IBM PC LAN Program was chosen to use on the networks because it was a commercially available proven product at a reasonable price and allowed for reliable communication. It was also fairly simple to implement and well-documented.

However, there are some major limitations in utilizing the IBM PC LAN Program. An example of this is that even though messages may be exchanged between computers, there is no means of saving messages for a computer, if that computer is not currently on the network. There is also no real file transfer protocols either. A limited file transfer such as a large message (about 1500 bytes) is all that is possible. The system is user friendly and menu driven. This can also be viewed as a disadvantage for the experienced user, since it is very time consuming to utilize hierarchically manipulated menus whenever you want to communicate.

V. INTERCONNECTION CONSIDERATIONS AND PROTOCOLS

A. GENERAL

There are a number of major differences between the PC network and Token-Ring network. In order to facilitate the interconnection of the two networks, these differences must be addressed and appropriate means of interconnecting must be identified.

B. MAJOR DIFFERENCES BETWEEN NETWORKS

1. Management

The PC network is a CSMA/CD access management while the Token-Ring network is a token passing access management system. Because of this, a gateway must be implemented to interconnect these different types of management systems. The gateway must use both hardware and software to allow for communication between the networks.

2. Transmission Media and Type

The transmission media for each network is different. The PC network uses CATV coaxial cable, while the Token-Ring network uses data-grade twisted pair cable. The PC network transmits data using a frequency modulated broadband system. The binary data flow of zeros and ones are converted into an analog signal and placed on a carrier frequency. The Token-Ring network operates on a baseband system where the data is

a serial stream of bits packed into formatted packets. These packets are sent and received at a specific designated rate.[Ref. 6:p. 114]. This interconnection can be implemented through a combination of hardware and software located at the gateway.

3. Speed

The PC network operates at approximately 2 Mb per second while the Token-Ring network transmits at approximately 4 Mb per second. Because of this both software and hardware are necessary to manage the difference in speeds. The data from the PC LAN transmitted to the Token-Ring LAN will have to be increased in speed and the opposite for the Token-Ring LAN to the PC LAN. The hardware also has to have adequate buffers to hold the faster flowing data. If buffer space is not adequate, then data will be lost in the queue.

4. Frame Format

The frame format for the PC and Token-Ring networks are somewhat similar; however, the Token-Ring requires an additional bit. This bit allows for a busy or free signal which is used for token access. Because of this some software conversion is necessary for frame transfer. The Token-Ring preamble to the packet contains this bit. The preamble must be added to the packet for transmission on the Token-Ring LAN and stripped off for transmission on the PC

LAN. Figure 6 gives an example of different types of packet/frame formats [Ref. 7:pp. 6,16].

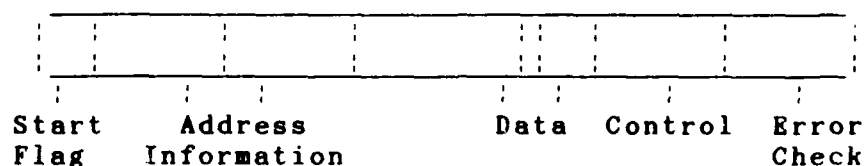

Fields present in a typical LAN packet

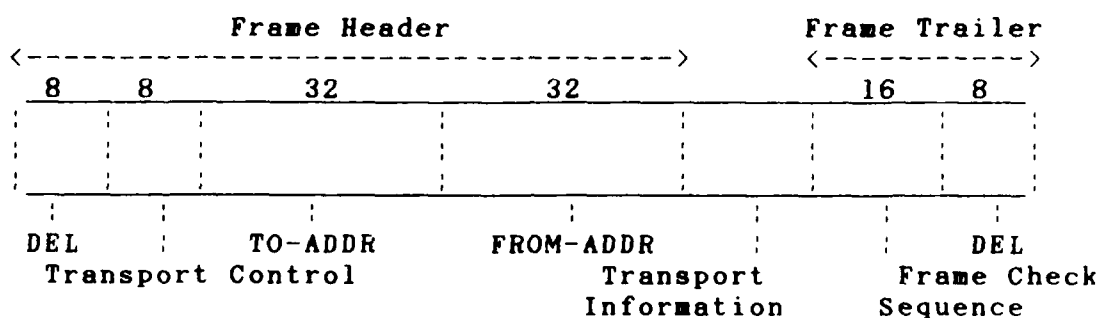

Packet structure of the IBM Token-Ring

Figure 6. Examples of Packets/Frames

5. Buffer Parameters

Buffer size is an extremely important consideration in connecting LANs. Buffers can increase LAN performance. They store data that is in transit and send it to the processor when the processor is ready to read the data or accept data when the processor is ready to write. They also assist in data transfer from one machine to another. Buffers requires space in the PC memory. This often results in a trade-off between space for buffers or space for application programs because of memory limitations. Consequently, the

size of the buffer is a major consideration in the speed of data flow, which can increase or decrease performance.

There are a number of buffers to consider in internetting. There are user, server and printer buffers. When a user wants to print a message, the data moves from the printer buffer of that machine to the request buffer of the server's machine. The server sends the message through its DOS buffers and stores the job on its print spool. From there, the data goes to the server's print buffers and then to the printer, where it may again be buffered in the printer before it is actually printed.

The buffer sizes for print servicing and message transmission of the PC and Token-Ring network must be compatible. If a buffer is too small in comparison to the amount of data being sent to it then some of this data could be lost. Consequently, all computers, both users and servers must have taken this configuration factor into consideration before different networks can be interconnected.

C. GATEWAYS AND BRIDGES

1. Interconnecting LANs

Depending upon the differences between networks, a gateway or bridge will be used to interconnect the networks. Specific factors are influenced by the type of equipment you need. These are performance, cost and flexibility for future

options. The more the networks differ, usually the more complex the interconnection becomes. The more complex the interconnection, then usually the cost escalates and often the performance suffers. Generally, the interconnection will become more complex with additional functions which are required to be performed.

2. Bridges/Repeaters

Bridges/repeaters are used in connecting two similar type LANs. They are the simplest of interconnection devices and also the least expensive. A repeater extends the distance the LAN can cover by reshaping and boosting its signals. Bridges are intelligent devices that perform media protocol conversion, such as coaxial cable to data-grade cable and also data packet filtering. They boost and reshape the transmission signal. Bridges work in the Physical and Data Link layers. If two PC LANs or two Token-Ring LANs were connected, they would use a bridge.

3. Gateways

Gateways are used to connect two different types of LANs. A gateway receives packets of data from the media of one LAN and then strips off the overhead data, i.e., token bit, from the packet which is specific to that LAN. It then reconfigures the packet with the different overhead data needed by the other LAN and redirects the packet. Gateways must understand both of the different type LANs protocols to

function. Usually a mixture of software and hardware are needed. Gateways provide connectivity at the Network layer. Some gateways can perform protocol conversions for all seven layers of the OSI model. Because of the complexity involved, gateways take some time to translate data between LANs, consequently performance can be adversely effected. Figure 7 demonstrates the functional components of one example of a gateway.

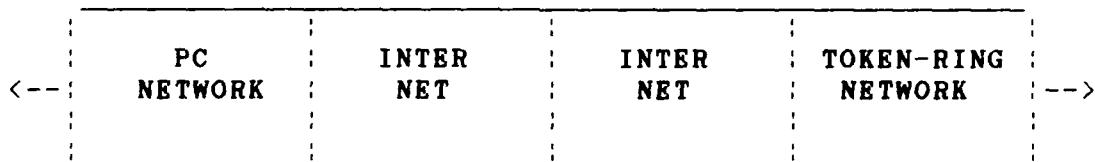

Figure 7. Gateway

VI. IMPLEMENTATION

A. GENERAL

The interconnection of the PC network and Token-Ring network is accomplished by a combination of hardware and software. This interconnection has been implemented on a small experimental system through a gateway which will allow the two different networks to communicate. After adequate testing is done, future plans call for the IBM PC network in Ingersoll Hall, Room 250 to be connected to the IBM Token-Ring network in Ingersoll Hall, Room 224.

1. Interconnection Gateway Hardware Plan

An IBM XT computer in Ingersoll Hall, Room 224, has been designated as a gateway for the interconnection of both networks. This computer will be configured with an IBM PC network adapter board and an IBM Token-Ring network adapter board. The Token-Ring adapter will be connected to a MAU in the Token-Ring by data-grade cable. The PC adapter board will be connected to the end of a coaxial cable, running from Room 250, where it is connected to the IBM PC network with a medium distance kit. This cable is composed of two 200-foot lengths (400 feet total) of CATV type coaxial cable. It has been installed above the ceiling of the second floor of the building. No changes are required to be made to the switch

settings on the PC adapter. The Token-Ring adapter requires changes to be made to the read-only memory (ROM) address and the interrupt level which the computer will use to address the adapter. These changes are required to be made to allow the gateway to distinguish the difference between the two different network boards and to correctly send and receive data for each.

B. SOFTWARE DESIGN

1. Interconnection and Network Programs

Each network has DOS 3.2 and IBM PC LAN programs installed. The SHARE.EXEC program from DOS 3.2 had to be replaced with DOS 3.3 version for internetting operations. The Token-Ring network also has the NETBIOS programs, TOKREUI and NETBEUI, installed. The IBM Interconnection Program will allow the PC network to communicate with the Token-Ring network using the NETBIOS interface.

2. Network Relationships

Each computer which will participate in the interconnection must have a unique name. The interconnection gateway must be configured with these names, which are designated in a data file. As a result of this, the gateway will be aware of what computers are transmitting from what LAN and then be able to receive and address data across the gateway. Each name must have a session with the interconnect

to be able to communicate. Consequently, unique names are necessary. The gateway will acknowledge data transfer received at the gateway from a sender of one LAN. However, no acknowledgement will be sent from the actual recipient of the other LAN to the initial sender by the IBM Interconnection Program. Consequently, unless a specific acknowledgement was incorporated into an application program, there is no way to know the message has actually been delivered.

3. Interconnection Specifications

a. Computer Names Limitation

A severe limitation with the IBM Interconnection Program is that only 16 names, 32 sessions and 28 NETBIOS commands are able to be used by each LAN in the gateway [Ref. 8:p. 3-1]. As was mentioned earlier, all computers in both LANs are configured as messengers and servers. The interconnection requires servers to reserve a total of three names and messengers, a total of two. This is because these computers can perform additional functions and this requires one name for each major function. Consequently, when implemented, only seven computers could communicate across the gateway (one server and six users).

Both PC and Token-Ring networks in the Administrative Sciences Department are configured with a transparent user name (% variable). If transparency was

possible in the interconnection, then all computers on both networks would have the ability to communicate through the gateway. However, there would still be a limitation of seven computers communicating across the gateway at one time in the implemented configuration.

Since the servers' names will not change, these will be retained in the configuration file needed for the interconnection. To allow for transparency (more than six users), batch files could be configured so that when the user wishes to communicate across the network, they will first access an interconnection batch file. This batch file will contain six unique assigned names to allow for communication to the other network (USER1 through USER6). The users' batch file will then check to see if any of these names are not being used. If there is a free name, it will be assigned to the user who wishes to communicate. When that user has finished his internet communication, then this unique name will be reset (by a batch file) as not being used. In this manner, internet unique names may be granted and user transparency may also occur. This allows for maximum flexibility for use of the network.

b. Message Size

The size of the largest message to be sent from one LAN to the other must be identified. If the size is exceeded, then datagrams will not be forwarded.

Additionally, sessions will be terminated as an error because of this. Consideration of network print buffers is also necessary if one LAN wishes to share printers from another. The print buffers must be large enough to receive incoming print requests. In configuring message size, care must be taken to insure that the 640K memory limitation on the XT computers is not surpassed when all additional configuration factors and programs are added in.

c. Performance

Performance is hindered by utilizing a gateway. It takes time for data to be transferred from one LAN to another because of the additional distance the data must travel. Also it takes time for protocol conversion in the gateway to translate different types of data formats from one LAN to another. The gateway must intercept the message and translate it by: reformatting the packet, changing the transmission speed, transforming the transmission media and type and then forward it. Performance considerations are also important in the number of sessions which are specified, a small number of sessions allows for faster response time.

There is a trade-off between user flexibility and performance. Ease of user interface between network and internetwork operations has been achieved through the use of

batch files. While these batch files simplify these operations, they also do hinder performance in their execution because they require additional time for their execution.

VII. APPLETALK AND ETHERNET NETWORKS

A. GENERAL

The Administrative Sciences Department has an AppleTalk network and 3Com Ethernet network laboratory. The primary purpose of these networks is to expose students to different types of networks and give them hands-on experience. A secondary purpose is to provide computer resources to the students. Many students favor Macintosh computers and these resources are heavily utilized, especially the Apple laser printer which is connected to the AppleTalk network.

B. LABORATORY HARDWARE

1. AppleTalk Hardware

The AppleTalk network consists of six Macintosh plus computers and one Apple laser printer. Each computer has 1Mb of RAM and there are two external hard disks, one 45 Mb and one 20 Mb. These disks will be daisy-chained together to give a total of 65 Mb of disk storage. All computers have a synchronous RS422 port built in which will allow them to be connected to a network. Each computer also has a 3-1/2" disk drive. All computers and the printer are physically connected to the network by shielded twisted pair cable. The AppleTalk Connector Kit has a 2 meter cable with an eight-pin mini-circular plug on each end, an AppleTalk connector

and cable extender. The AppleTalk connector is plugged into the computer with an eight-pin plug and the cable is attached to the other end of the connector box via another eight-pin plug. There are two plugs on one end of the connector box. Using the other plug, the computers are daisy-chained together by connecting one end of the cable from a computer to the AppleTalk connector of the next computer. As demonstrated in Figure 8, the computers are attached in a straight line or bus with no dangling connect cables at each end of the bus [Ref. 9:p. 7].

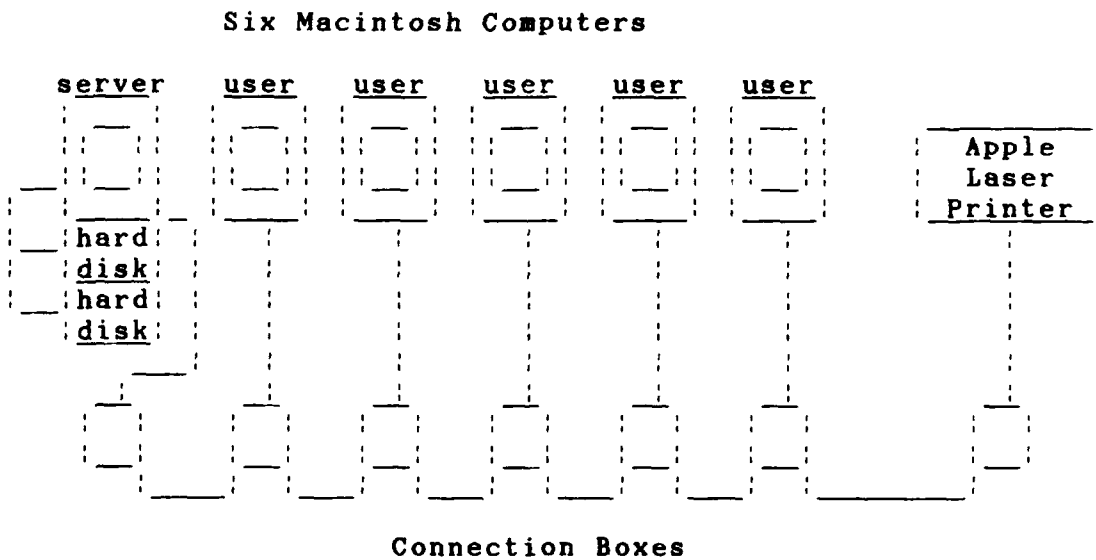

Figure 8. AppleTalk Network Connection Example

There is an AppleTalk System Connector Kit for the laser printer. This differs from the regular connector by using a nine-pin plug to connect to the laser printer. If additional cable is needed, extender kits are available with 10 meter cable lengths. Custom wiring kits are also available which allows for cable to be cut to any desired length (maximum recommended length of no more than 300 meters). The AppleTalk network, while extremely easy to install and connect, is a very slow network. The transmission speed is approximately 230.4 Kb per second. Also, a maximum of 32 connections (nodes) can be made in the network.

2. 3Com Ethernet Hardware

The 3Com Ethernet network consists of five IBM PC/XT computers and a 3Com special purpose server computer. The PC/XTs each have a 20 Mb hard card or hard disk and 640 Kb of RAM. Each has one or two floppy disk drives and some are configured with turbo-accelerator boards. The 3Com server has a 70 Mb hard disk and no floppy disk drives. Consequently, to install software or perform maintenance functions, an IBM PC/XT will be used in conjunction with the special purpose server. A modification/addition has been made to this server by attaching a device that contains additional ports and connectors. This allows for numerous different types of connections to be made to it.

Each IBM computer contains an Ethernet adapter board. A "T" connector is attached to the board. Thin Ethernet cable is attached to this "T" connected by a "BNC" connector. The computers are daisy-chained together with one end attached to the 3Com server and the other end capped off with a terminator cap. The Ethernet transmits at approximately 10 Mb per second.

C. NETWORK CHARACTERISTICS

1. AppleTalk Network

a. Topology

The AppleTalk network is connected in a physical and logical bus topology. The computers are physically connected in a straight bus topology, no ring type connection will function on this network. When a computer transmits, it sends a signal the full length of the bus. Each computer has only one connection to the bus. This is a very simple configuration and very easy to install. It is also easy to make changes, such as add/delete devices or lengths of the bus.

b. Transmission Media

Apple uses a shielded twisted pair cable system for its network. It is inexpensive and easy to install. Since the network speed is relatively slow, it is an appropriate medium and fairly reliable over short

distances. The transmission signal is baseband, bi-phase space signal.

c. Management

The AppleTalk network uses a CSMA/CA (collision avoidance) management systems. Each device on the bus will listen before it transmits to insure the bus is clear. If the bus is busy, then devices wishing to transmit will wait a specific amount of time plus an additional random amount of time (based on traffic) before they transmit. This system tries to avoid collisions; if a collision does occur, the devices will retransmit. No more than six to ten computers are recommended on the network because of performance considerations.

d. Network Software

Each Macintosh utilizes a system boot disk to start the network. AppleShare software is utilized on the network. In the near future, the AppleTalk network will be connected to IBM PCs with TOPS network boards and software. The Transcendental Operating System (TOPS) was chosen as the interconnection software because of its ability to allow Macintosh and IBM PC computer to communicate.

2. 3Com Ethernet Network

a. Topology

The 3Com Ethernet is connected in a physical and logical bus topology. It is simple and easy to add or

delete computers. Thin Ethernet coaxial cable forms a common communications medium for all computers that are connected to the network.

b. Transmission Media

A broadband coaxial thin Ethernet cable is used in this network. It is much easier to install than CATV coaxial cable. Computers are easily connected/disconnected to the network by simply plugging in a "BNC" connector to the "T" connector attached to the Ethernet board.

c. Management

The 3Com Ethernet is based upon the IEEE 802.3 Ethernet standards. This Ethernet system is a baseband coaxial system operating at approximately 10 MHz. It is a CSMA/CD management system similar to that described in the IBM PC network.

d. Network Software

3Com software has been installed in the special purpose server by using an IBM PC connected to it. This software will allow multiple PCs to share its hard disk and perform mail and other functions. Future thesis work may be done in this area.

VIII. PROTOCOLS AND STANDARDS

A. COMPATIBILITY CONSIDERATIONS

Today LANs are bought for their applications rather than on vendor or network technology. This means that different applications are likely to be implemented using a variety of LANs from different vendors. [Ref 10:p. 34]

Often a variety of different types of vendor equipment will make up the elements of the LAN. Equipment will be purchased because of performance, price or application considerations.

With the number of different types of equipment available, standards and protocols become increasingly important.

Without an attempt to standardize protocols within layers or interface between layers, no two communications systems would be compatible. The desired goal is to establish a local area network specification with recognized interface and protocol standards that will allow networks and devices from different vendors to communicate with each other. [Ref. 6:p. 117]

Protocols define how data is transferred, formatted, error checked and packaged. The IEEE 802 Committee has introduced a number of standards, but each major equipment manufacture often will retain their own standards, i.e., IBM with SNA and DEC with DNA.

In dealing with interconnecting these different types of machines, these environments more closely resemble democratic, New England town meetings than traditional master-slave relationships. [Ref. 11:p. 34]

B. DoD REGULATIONS

The DoD has a unique situation with respect to equipment procurement. There are a number of government legislation and regulations that cover automatic data processing (ADP) equipment. The Brooks Bill covers a broad area from computers, software, firmware, ancillary equipment to service support. The Competition in Contracting Act of 1984 and Warner Amendment give guidelines for acquisition practices. The primary objective of these regulations is to provide free and open competition in government ADP procurement so as the government may benefit economically through this competition.

As a result of this, compatibility between equipment often becomes a problem.

If an agency does not establish standards, it runs the risk--and the probability--of operational chaos. If a standard is established, the obvious, unfair advantage of the manufacturer with standards compliance is unacceptable in any truly competitive procurement environment. [Ref. 12:p. 19]

Consequently, as a result of this legislation, often procurements will be functionally driven using least cost--minimum need procurement criteria and compatibility problems will arise.

C. COMPATIBILITY PROBLEMS

A specific example of a compatibility problem encountered in the implementation of this thesis was in the purchase of the AT clone microcomputers for the Token-Ring network. The

clones were supposed to be 100% compatible with IBM AT computers.

During implementation of different functions on the network, it was found that the IBM computers operated on a different Token-Ring board interrupt level than the clones did. Therefore, the clone computers were not truly 100% compatible to the IBM, but this was not known until complex integration of various devices were attempted.

The true test of compatibility is when we bring the items in-house and test everything. Sometimes compatibility is determined through trial and error. Some things no one in their right mind would think of looking for. [Ref. 13:p. 44]

Compatibility is less of a problem if you are able to specify a specific sole source device that has demonstrated it will work on certain LANs. IBM's documentation was also very clear and thorough. The clones did not provide adequate documentation to be able to determine what interrupt level should be used for the various functions that were being implemented.

DoD has not restricted the purchasing of LANs. It is encouraging vendors to publish specific, acceptable, mutually agreed upon standards to have compatibility between different types of LANs and favors the OSI model for all vendors to conform to.

IX. SUMMARY

A. GENERAL

The issues encountered while interconnecting the LANs in the Administrative Sciences Department were an exciting challenge to conquer and then implement. Steps taken in solving the issues of interconnecting different types of LANs included the following:

- Through examination of existing LANs hardware and software.
- What fundamental requirements and objectives were to be accomplished.
- What were the specific hardware objectives, i.e., to be able to use a laser printer on another LAN.
- What were the specific software objectives, i.e., to be able to share certain application programs from a server.
- What protocol conversion had to be accomplished and what degree of interconnection strategy should be pursued, i.e., full file transfer versus message passing.
- How friendly should the user interface be and how that impacts on performance.
- Government regulations and their effect on compatibility.

Currently there is much interest in internetting, both in research and commercial applications.

According to a Federal Office Automation Support Center survey of federal agencies, by 1986 there were at least 2 million personal computers installed in more than 45,000 LANs. [Ref. 14:p. 27]

The number of new LANs is expected to increase steadily. A logical outgrowth of these LANs is the need for the ability to interconnect them and this need will also continue to increase.

As was demonstrated earlier, there are a number of different types of architectures, protocols and standards used by various vendors.

Hardware vendors just don't have the specialized expertise to understand these protocols in enough details or to keep up with their evaluation. [Ref. 11:p. 46]

This fact was encountered with two major vendors when implementation problems arose. Since vendors place a monetary value on their time, unless support contracts were procured, no further support was provided. Even if these contracts could be procured, after initial consultation attempts were made, the knowledge and expertise offered by these companies was of questionable help. Because of this, a new industry has recently been introduced:

System integrators are increasingly called on to put together networks of machines from different vendors. [Ref. 11:p. 43]

Consequently, it can be seen that interconnecting different types of networks is often a complex, highly technical task. Future developments in this field are moving towards an integrated computer, data and communication system.

The result has been a growing overlap of the computer and communications industries from component fabrication to system integration. [Ref. 15:p. 14]

Developments of this type could encounter major compatibility problems unless protocols could be agreed upon in the future.

B. NETWORK SELECTION

Selection of the four different LANs in the Administrative Sciences Department provided examples of most of the major LAN technologies used today. CSMA/CA, CSMA/CD and token passing management examples are provided along with both broadband and baseband transmission types. Many of these LANs or similar types of these will be encountered in the future by the military officers that are currently students here now.

The selection and installation of this equipment both provided for educational examples of LANs and functional utilization. It also provides for flexibility for future upgrading and expandability/connectivity to a planned campus area backbone network. Numerous types of both hardware and software have been made available for familiarization and hands-on experience.

Many military installations utilize major IBM products and systems. As a result of this, for compatibility purposes, IBM LANs or LANs from a single vendor allow for

ease of interconnection to other IBM or IBM compatible machines. Also, many facilities already have Token-Ring LANs and many more will be procured in the future.

IBM has stated that it will put its entire product line on Token-Ring. Indeed since 1984, the company has introduced Token-Ring interfaces for almost all of its lines of computers. [Ref. 16:p. S3]

If IBM, the major computer corporation in the industry, is using this technology and plans on its continued support in the future, other major vendors will also follow in their footsteps. Consequently, it can be seen that the choice of selecting some of the particular LANs was very well thought out and the likelihood of this technology to be utilized for some time in the future is very certain.

C. TECHNICAL CHALLENGES

Many technical challenges were faced both in hardware and software during implementation. Hardware challenges included compatibility issues, set up and installation of equipment, application requirements that pertained to specific hardware types and also coordination with engineers for such services as cable installation and connection. Memory requirements were strained because of the large amount of memory consumed by the different LAN and interconnection programs.

Documentation and expertise were found to be scarce or nonexistent. There is a great amount of documentation on installation and applications of specific types of LANs.

However, when interconnecting different types of LANs, unique and new problems arose that were not covered in any documentation. Often trial and error was the common method of implementation.

Software compatibility was often dependent on which application programs and what type of equipment was utilized. Numerous programs and machines will only run with a DOS operating system. Compatibility during the interconnection of the Token-Ring network with the PC network went very smoothly since all IBM software was used except for the problem with the SHARE.EXE program in DOS 3.2.

Numerous problems were encountered with 3Com software. The documentation was found to be lacking, sometimes confusing and sometimes insufficient for the network interconnection on the 3Com server.

A specific example of a software application challenge for networking was the installation of a batch file to start a LOTUS program. Both monochrome and color monitors were being used on the network. Consequently, the driver for the LOTUS program had to be modified to allow for use of both types of monitors. This was done by using the profile batch file (Appendix C) in conjunction with the modified driver program.

D. USER INTERFACE AND PERFORMANCE

When the network and internet connections were designed, user interface was of primary concern. The system had to be friendly enough for even a novice user to understand it. Consequently, a number of batch files were designed to start the network, allow for interconnection and reduce the amount of type strokes required by the user.

As a result of this, performance often suffered to allow for maximum choices of user equipment and programs. Additional batch files were written and originals modified to make this procedure more efficient. Unnecessary copying of programs not needed by individual machines was eliminated and this saved time and memory space. Overall performance of internet programs was much degraded with respect to normal single LAN operations. Longer transmission distances and protocol conversions required additional time.

E. CONCLUSION

The network operations implemented for the Administrative Sciences Department was intended for use by the students of the Naval Postgraduate School. Commercial and military networks will most likely vary in their installation and use of LANs because of the differences of environments.

Design and choice of these networks will give the students a broad background in different types of networks

and examples of their interconnection. Specific effort was expended to make these operations user friendly.

The issues raised in this thesis, combined with the physical installation of different networks and their interconnection should give the reader some insight into the problems of interconnecting different types of local area computer networks.

APPENDIX A

Examples of Profile and Environmental Type Batch Files

PROFILE.BAT

```
FOR %%F IN (TN26 TN27 TN28 TN29 TN30 TN31) DO IF
  %%F==%MACHINE% SET GROUP=GROUP1
FOR %%F IN (TN20 TN21 TN22 TN23 TN24 TN25) DO IF
  %%F==%MACHINE% SET GROUP=GROUP2
FOR %%F IN (TN18) DO IF %%F==%MACHINE% SET GROUP=GROUP3
FOR %%F IN (TN12 TN15) DO IF %%F==%MACHINE% SET GROUP=GROUP4
%GROUP%
```

GROUP1.BAT

```
SET MONITOR=EGA
SET MATH=N
SET MODEM=N
D:
1DIR
```

START.BAT FOR USERS

```
rem
rem
rem Objective
rem This file starts the network program.
rem
rem Input:
rem The user inputs the name on the command line. Other input
rem comes from the environment variables in each machine.
rem These variables are set by the autoexec.bat file.
rem
rem Output/Results:
rem One of two mutually exclusive results is expected.
rem a) A successful network start and in this case
rem AUTOUSR#.bat on the server will execute, or b) An
rem unsuccessful start which will be attributed to duplicate
rem names and a message to this effect will be displayed.
rem
rem
rem ECHO OFF
rem
rem Step 1; Save Name, Determine network type and Start it.
rem
SET USERNAME=%1
PATH=%NETPRG%;
rem
IF %NETWORK%==PCNET GOTO START
rem
TOKREUI
NETBEUI
rem
:START
rem
NET START MSG%1/SRV:5/ASG:12/USN:3/NBC:5/NBS:2K/PB1:4K/PB2:2K
IF ERRORLEVEL 1 goto ERROR
NET USE %NETPRGDR% \\%PRIMSERVER%\NETPRG
%NETPRGDR%
%AUTOUSR%
rem
rem Program ends here for successful start.
rem
rem ERROR, DUPLICATE NAMES
rem
:ERROR
rem
CLS
```

```
ECHO .
ECHO .
ECHO   You Have used a NAME that is already in use on the
ECHO   network.  Or you are trying to start the network
ECHO   while it is already operational.  You may check
ECHO   whether network is operational by pressing {cntl},
ECHO   {alt}.  {Break}.  If the network menu appears, it
ECHO   is operational.  If not, retype the "START" {your
ECHO   name}" using another name.
ECHO .
ECHO .
PAUSE
rem
rem end of program for unsuccessful start.
```

Appendix A.2

AUTOEXEC.BAT FOR USERS

```
rem Objective:
rem This file sets the environment variables for the users
rem and displays the autoscr.scr.
rem
rem Input:
rem autoscr.com created from autoscr.scr(ASCII file)
rem Output/Results:
rem No output files
rem
rem ECHO OFF
rem
rem Step 1; set environment variables
rem
rem set network, server name and printers;
rem
SET NETWORK=TOKEN
SET PRIMSERVER=NORMS
SET PRINTSERVER=PRINTER
SET NETPRG=C:\APPS\NETWORK
SET AUTOUSR=AUTOUSR1
SET BATCHDR=E:
SET PRIMDR=L:
SET DEFAULTPATH=%PRIMDR%\DOS;%PRIMDR%\NETWORK;%PRIMDR%;
rem
rem set hardware configuration;
rem
SET HARDDISK=Y
SET MATH=Y
SET MODEM=N
IF %HARDDISK%==y goto HARD2
:HARD1
SET PROGDR=C:
GOTO HARDEXIT
:HARD2
SET PROGDR=D:
:HARDEXIT
rem
rem step 2; instructions
rem
QUADCLOCK
AUTOSCR
rem
rem end of program
```

Appendix A.3

START.BAT (Original) for Token-Ring Network Users

```
: *** Start.Bat = Start.TU2 ***
: *** For Token Ring User With 3270 Emulation ***
ECHO OFF
: *** Establish Path to Network and DOS Programs Residing on
: *** User Computer ***
PATH C:\NETWORK;C:\APPS\DOS
: *** Establish Access for LDIR to LDIRDATA Sub Directory ***
APPEND C:\LDIRDATA
ECHO ON
: *** Load Token-Ring Programs ***
TOKREUI
NETBEUI
: *** Start the User Computer on the Network, Using Name
: *** Provided by User ***
NET START MSG%1/SRV:1/ASG:10/PB1:16K/USN:3/CMD:12/SES:18
: *** Request Use of Server Directories and Printer ***
NET USE E: \\TN3\APPS
NET USE F: \\TN3\MAINFRAM
NET USE D: \\TN3\DISKD
NET USE LPT1 \\TN3\PRINT
: *** Access D Directory which contains LDIR and Program
: *** Batch Files. This is accomplished by loading PROFILE
: *** from the E drive which sets either Group1, Group2,
: *** Group3 or Group4 batch files, each of which changes
: *** the drive to D and loads LDIR. ***
E:
: *** Load Profile ***
PROFILE
```

APPENDIX B

```
: **** Lotus Batch File.
: **** 1- Check for monitor type and if B&W issue warning
: **** 2- Start Lotus using environment variable monitor.
: **** 3- Return to D: drive.
: ****
:
: 1- Check Environment Variable.
if not %MONITOR%==BW goto cont
echo off
cls
echo .
echo .
echo This computer is equipped with a B&W monitor and will
echo not display graphics. Press any character to continue.
echo .
echo .
pause
:
:
:cont
e:
cd\sprdsht\lotus
lotus %monitor%
cd\
d:
```

Example of LOTUS Batch File

LIST OF REFERENCES

1. IEEE Project Local Network Standards: Introduction, Draft C, May 17, 1982.
2. Shneiderman, Ben, Designing the User Interface: Strategies for Effective Human-Computer Interaction, Addison-Wesley Publishing Co., Menlo Park, CA, 1987.
3. Schneidewind, N. F., "Interconnecting Local Networks to Long Distance Networks," Computer, IEEE Computer Society, Vol. 16, No. 9, September, 1983.
4. Berry, Paul, Operating the IBM PC Networks, SYBEX, Inc., Alameda, CA, 1986.
5. IBM PC Network Technical Reference, IBM Corp., 1986, Boca Raton, FL.
6. Jordan, Churchill, Communications and Networking, Brady Co., Bowie, MA, 1983.
7. Hopper, Temple, Williamson, Local Area Network Design, Addison-Wesley, Menlo Park, CA, 1986.
8. IBM Token-Ring Network/PC Network Interconnection Users' Guide, IBM Corp., 1986, Research Triangle Park, NC.
9. AppleTalk Personal Network, Apple Computer, Inc., 1987, Cupertino, CA.
10. Witkowicz, Ted, "Connecting LANs, Differentiating Gateways, Bridges, Routers and Repeaters," LAN - The Local Area Network Magazine, Newton and Friesen Publishers, New York, NY, February, 1988.
11. Livingston, Dennis, "Software Links Multivendor Networks," Mini-Micro Systems, Cahners Publishing Co., Newton, MA.
12. Bateman, Lynn, "Acquisitions - Federal Communications Week, GSN, Inc., Boston, MA, January 11, 1988.

13. Schaidt, Patricia, "Compatibility Maze, What It Is and How To Get It," LAN - The Local Area Network Magazine, Newton and Friesen Publishers, New York, NY, September, 1987.
14. Casatelli, Christine, "New Network Technologies," Federal Computer Week, January 25, 1988.
15. Stallings, William, Data and Computer Communications, Macmillan Publishing, New York, NY, 1985.
16. Deboever, Larry, "LANs, See How They Grow," Computer World, C.W. Publishing, Framingham, MA, January 25, 1988.

INITIAL DISTRIBUTION LIST

| | No. Copies |
|--|------------|
| 1. Defense Technical Information Center Cameron Station Alexandria, VA 22304-6145 | 2 |
| 2. Library, Code 0142 Naval Postgraduate School Monterey, CA 93943-5002 | 2 |
| 3. Director of Information Systems Office of Chief of Naval Operations (OP-945) Navy Department Washington, DC 20350-2000 | 1 |
| 4. Commander US Army Intelligence Center and School Attn: ATSI-SP Fort Huachuca, AZ 85613-7000 | 2 |
| 5. Director Computer Science School Soldier Support Center Fort Benjamin Harrison, IN 46216-5570 | 2 |
| 6. Superintendent Computer Technology Programs, Code 37 Naval Postgraduate School Monterey, CA 93943-5000 | 1 |
| 7. Superintendent Attn: Prof. N. F. Schneidewind, Code 54Ss Naval Postgraduate School Monterey, CA 93943-5000 | 1 |
| 8. Superintendent Attn: Y. K. Mortagy, Code 54My Naval Postgraduate School Monterey, CA 93943-5000 | 1 |
| 9. Chief, US Army Instructor Group Attn: Major Daniel C. Malakie Air Command and Staff College, Bldg 1402 Maxwell Air Force Base, AL 36112-5542 | 3 |