

MMR. FDE COPY

2

POWER PLANT ENGINEERING REPORT NO. 3 A

STANDARD FIRE TEST APPARATUS AND PROCEDURE

(FOR FLEXIBLE HOSE ASSEMBLIES)

AD-A200 844



10A TECHNICAL UNIT

AUG - 8 1983

DOT LIBRARY M493.2

REVISED  
MARCH 1978

DTIC  
ELECTE  
NOV 3 0 1988  
S E D

U.S. DEPARTMENT OF TRANSPORTATION  
FEDERAL AVIATION ADMINISTRATION  
Flight Standards Service  
Washington, D.C. 20591

This document has been approved  
for public release and sales in  
distribution is unlimited.

88 11 30 021

POWER PLANT  
ENGINEERING REPORT NO. 3A  
(Revised)

STANDARD FIRE TEST  
APPARATUS AND PROCEDURE  
(For Flexible Hose Assemblies)



<b>Accession For</b>	
NTIS GRA&I	<input checked="" type="checkbox"/>
DTIC TAB	<input type="checkbox"/>
Unannounced	<input type="checkbox"/>
Justification	
By _____	
Distribution/	
<b>Availability Codes</b>	
Dist	Avail and/or Special
A-1	

Prepared by:  
Propulsion Branch  
Engineering & Manufacturing Division

Revision 3A Prepared by:  
E. P. Burke

Revision 3A Approved by:  
T. G. Horeff

## Table of Contents

	<u>Page</u>
Standard Fire Test Apparatus and Procedure	1
Appendix I, Description of Test Apparatus	5
Appendix II, Test Burner Standardization Apparatus	6
Appendix III, Criteria/Qualified Burners	15
Table 1. Burner Specifications and Performance	25

### List of Figures

Figure 1. Hose Assembly Test Bench	3
Figure 2. Hose Test Control Panel	4
Figure 3. Burner Standardization Apparatus	8
Figure 4. Lennox OB-32 Temperature Profile	19
Figure 5. Carlin 200 CRD Conversion Oil Burner	20
Figure 6. Carlin 200 CRD Burner	21
Figure 7. Air Tube Reduction Cone	22
Figure 8. Burner Tube Extension	23
Figure 9. Carlin 200 CRD Temperature Profile	24
Figure 10. Stewart-Warner HPR-250 Conversion Oil Burner	26
Figure 11. Stewart-Warner HPR-250 Burner	27
Figure 12. Stewart-Warner HPR-250 Temperature Profile	28
Figure 13. Stewart-Warner FR-600 Conversion Oil Burner	29
Figure 14. Stewart-Warner FR-6000 Burner	30
Figure 15. Stewart-Warner FR-600 Temperature Profile	31

### List of Drawings

Drawing No. TD271-1A-B. Assembly-BTU Transfer Device for Torch Standardization	9
Drawing No. TD271-1-A. Reducer-BTU Transfer Device for Torch Standardization	10
Drawing No. TD271-1-1-B. Inlet Tube-BTU Transfer Device for Torch Standardization	11
Drawing No. TD271-2-B. Outlet Tube-BTU Transfer Device for Torch Standardization	12
Drawing No. TD271-3-B. Thermometer Mounting-BTU Transfer Device for Torch Standardization	13
Drawing No. TD271-4-B. Test Specimen-BTU Transfer Device for Torch Standardization	14

### List of Tables

Table 1. Burner Specifications and Performance	25
List of References	32

# STANDARD FIRE TEST APPARATUS AND PROCEDURE

(For Flexible Hose Assemblies)

## Standard Fire Test Apparatus and Procedure

*document describes a*

→ This method of test is intended to determine the fire resistance of flexible hose assemblies under simulated conditions. The test is aimed at producing a typical aircraft powerplant fire, vibration of the type encountered during rough engine operation, and the various flight conditions of fluid flow, pressure, and temperature. *Keywords: test method; test fixtures; hose fittings; hose connections; (AST)*

The fire test apparatus described in Appendix I of this report, or equivalent equipment, shall be used for determining fire resistance. The main components of this apparatus are:

- a. Burner: See Appendix III
- b. Vibrating mechanism.
- c. Bench.
- d. Hood.
- e. Temperature measurement and recording.
- f. Oil circulator and heater.

The flame produced by the burner shall be calibrated by means of the standardization device and method described in Appendix II and shall have a minimum B. t. u. value of 4500 B. t. u. per hour.

The length of hose assembly to be tested shall be not less than 24-inches. The hose shall be mounted horizontally on the test bench (see figure 1) and shall include one full 90° bend. The hose assembly shall be located inside of the hood except when limited by physical characteristics such as recommended minimum bend radius. The nearest surface of the hose is to be located 4 inches beyond the burner barrel extension. SAE 20 oil at a temperature of not less than 200°F. shall be circulated through the hose assembly and system to remove all air from the piping system and to establish the required operating temperature. The oil flow rate and pressure parameters specified in the applicable Technical Standard Order (TSO) shall be established and maintained during the test. The vibrating mechanism shall then be started and the assembly checked to make certain that no resonant whipping occurs. The fan which affects the air movement over the assembly shall be started. The actual fire test is then begun by igniting the burner and starting the chronometer simultaneously. A satisfactory and convenient means of accomplishing this is by use of the control panel shown in figure 2.

A hose assembly is considered acceptable if it complies with the test conditions and parameters for the time period specified in the TSO without any evidence of leakage. Leakage shall be detected by visual observation from a distance of not more than five feet, at a position where the specimen, flame, and drip pan are visible.

THIS PAGE HAS INTENTIONALLY BEEN LEFT BLANK



FIGURE 1. HOSE ASSEMBLY TEST BENCH

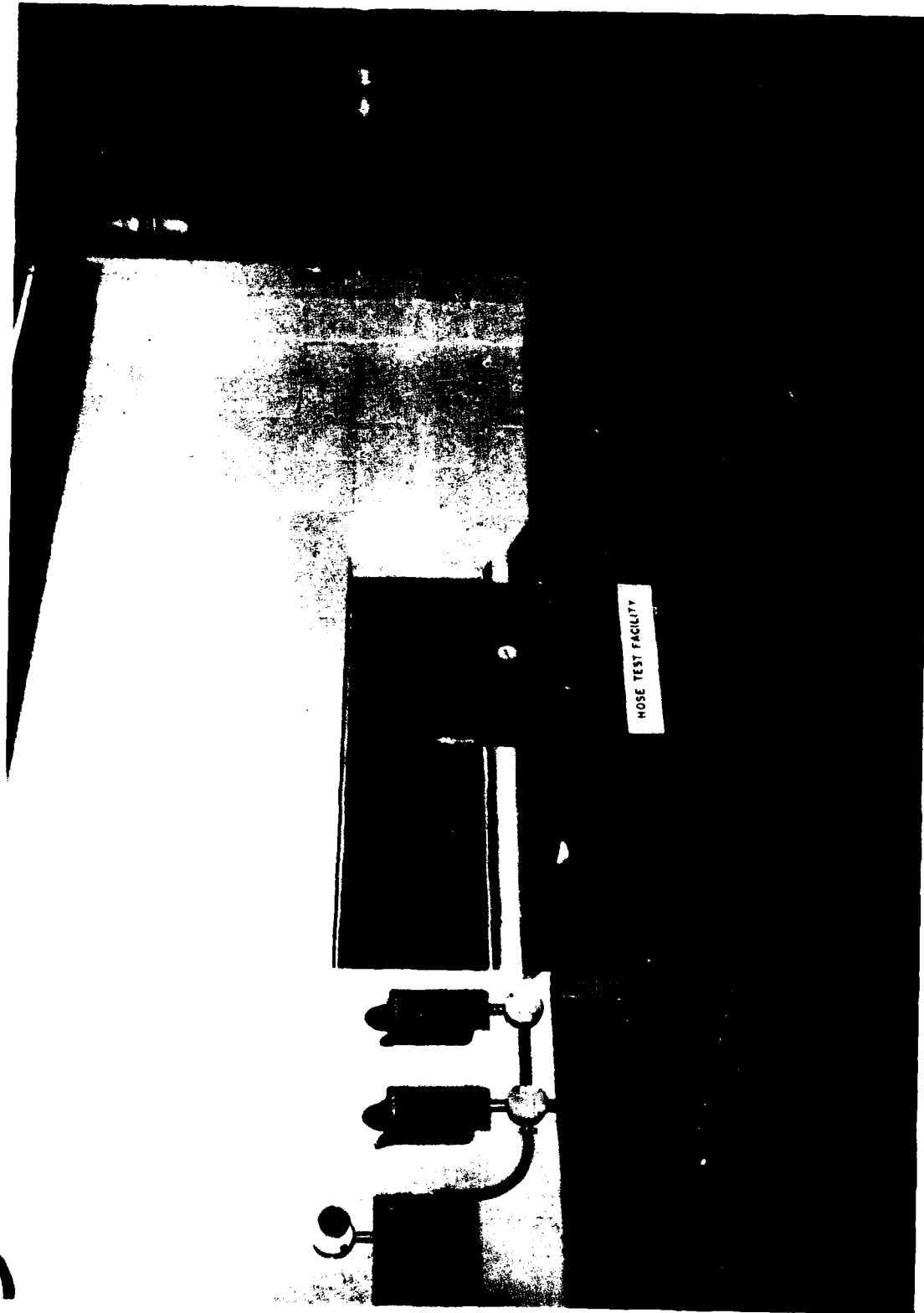

FIGURE 2. HOSE TEST CONTROL PANEL

## APPENDIX I

### Description of Test Apparatus

**TEST BURNER** - The burner used to produce the flame shall be a modified gun-type conversion oil burner as described in Appendix III or equivalent. With the oil delivery rate at 2 gallons per hour, adjust the inlet air to achieve the controlling characteristics of the flame (see Appendix III). The portion of the flame in which the hose assembly is to be tested should deliver a minimum heat output of 4500 B. t. u. per hour. Because slight variations in the air pressure as determined by the manometer readings will produce a marked variation in the flame B. t. u. output, it may be necessary to vary the air pressure slightly to obtain the required rate of heat transfer.

**VIBRATING MECHANISM** - The vibrating mechanism is shown in Figure 1. One end of the hose assembly shall be subjected to a total lateral or longitudinal displacement of not less than 1/8 inch (1/16 inch on each side of normal) at 2000 c. p. m. The vibrated end of the hose assembly shall be subjected to the flame. The vibrating fixture shall be as light as possible to avoid excessive heat transfer or loss through the fixture.

**BENCH** - The bench consists essentially of a steel table, 60 inches wide, 28 inches deep, and 32 inches high. Mounted on this bench is the vibrating mechanism and a hood.

**HOOD** - The hood (see figure 1) is 25 inches wide and 25 inches high. The vibrated fitting is located 7 inches back of the open front of the hood. The rear end of the hood is ducted to a fan, which draws air through the hood opening at a velocity of 400 f. p. m. as measured by an Alnor velometer located at the hose assembly specimen. This air movement aids in keeping the flame horizontal and in exhausting fumes.

**TEMPERATURE MEASUREMENT AND RECORDING** - The temperature sensing system including the thermocouples and indicator shall have an allowable overall error of  $\pm 1$  (one) percent at 2000°F. The flame temperature shall be measured four inches from the end of the burner barrel extension. A sufficient number of the thermocouples shall be used to assure that the specified temperature exists at least along the entire end fitting and the hose for a distance of not less than five inches.

**OIL CIRCULATOR AND HEATER** - The oil circulating and heating equipment consists of an electrically driven oil pump and an oil tank with a thermostatically controlled immersion heater. The plumbing of the oil system also includes pressure relief valves, flow indicators, pressure gages, and control and selector valves.

## APPENDIX II

### Test Burner Standardization Apparatus

In order to standardize the B.t.u. output of the flame utilized in testing, B.t.u. measuring equipment shall be used. The heat transfer surface, which is similar in shape to a hose, may be inserted in the flame from the test burner and a B.t.u. measurement obtained for the portion of the flame to which a hose test specimen is subjected during a test. Such measurement will enable adjustment of the burner until a standard minimum B.t.u. value of 4500 B.t.u. per hour, as measured by the standardization device, is obtained.

**FABRICATION OF APPARATUS** - The illustration of the apparatus (Figure 3) shows the layout of the complete assembly. A 5-foot constant head of water above the heat transfer tube and a 2-foot drop to the end of the tailpipe are specified so as to obtain consistent flow conditions. A standard 1/4-inch metering valve is attached just before the tail pipe for adjustment of the water-flow rate. A gallon-measuring container or a container and a weighing scale are also required.

The drawings, Nos. TD-271-1A-B, TD-271-1-A, TD-271-1-B, TD-271-2-B, TD-271-3-B and TD-271-4-B, specify materials and dimensions for fabrication of the center portion of the device. The materials needed are readily available and inexpensive. Certain of the parts require machining. The mercury thermometers should be inserted into the wells, with the bulb within 1/16-inch of bottoming in the asbestos base tubing. The woven copper fabric should be inserted carefully so that it causes the flowing water to be mixed without restricting the flow below the maximum flow rate of the 1/4-inch metering valve. Note: Immersion thermocouples may be used instead of mercury thermometers.

**PROCEDURE** - The following preparations are necessary prior to making a measurement:

- (1) Water should be supplied at a temperature not lower than 50°F. and not higher than 70°F.
- (2) The waterflow rate should be adjusted to 500 pounds per hour, which is approximately equal to 1 gallon per minute.
- (3) The external surface of the copper tubing should be cleaned with fine steel wool before each test.
- (4) The hood ventilating fan shall be turned on and the fire test burner should be carefully adjusted to produce a  $2000 \pm 150^\circ\text{F}$ . flame. The temperature shall be determined at a point which is four inches beyond the end of the burner barrel extension. The thermocouple shall be removed upon completion of the flame temperature determination.
- (5) With the water flowing through the device, the heat transfer tube should be centered in the flame in the same location that a hose assembly would be placed for testing. A 3-minute warmup period should be allowed to obtain stable conditions before temperature measurements are recorded. Note; the 3 minutes should be conducted away from the heat transfer tube to prevent build-up of carbon.

After the warmup period, the temperatures indicated by the inlet and outlet thermometers are recorded every 1/2-minute during a 3-minute period. The average difference in temperature (°F.) of the inlet and outlet water multiplied by the rate of the water flow (500 pounds per hour) equals the rate of B.t.u. increase of the water flowing through the device, and this value is an indication of the severity of the portion of the flame in which hose assemblies are tested.

In addition to these general procedures, those specific procedures called for in TSO-C42, Propeller Feathering Hose Assemblies and TSO-C53a, Fuel Engine Oil System Hose Assemblies shall be followed as applicable.

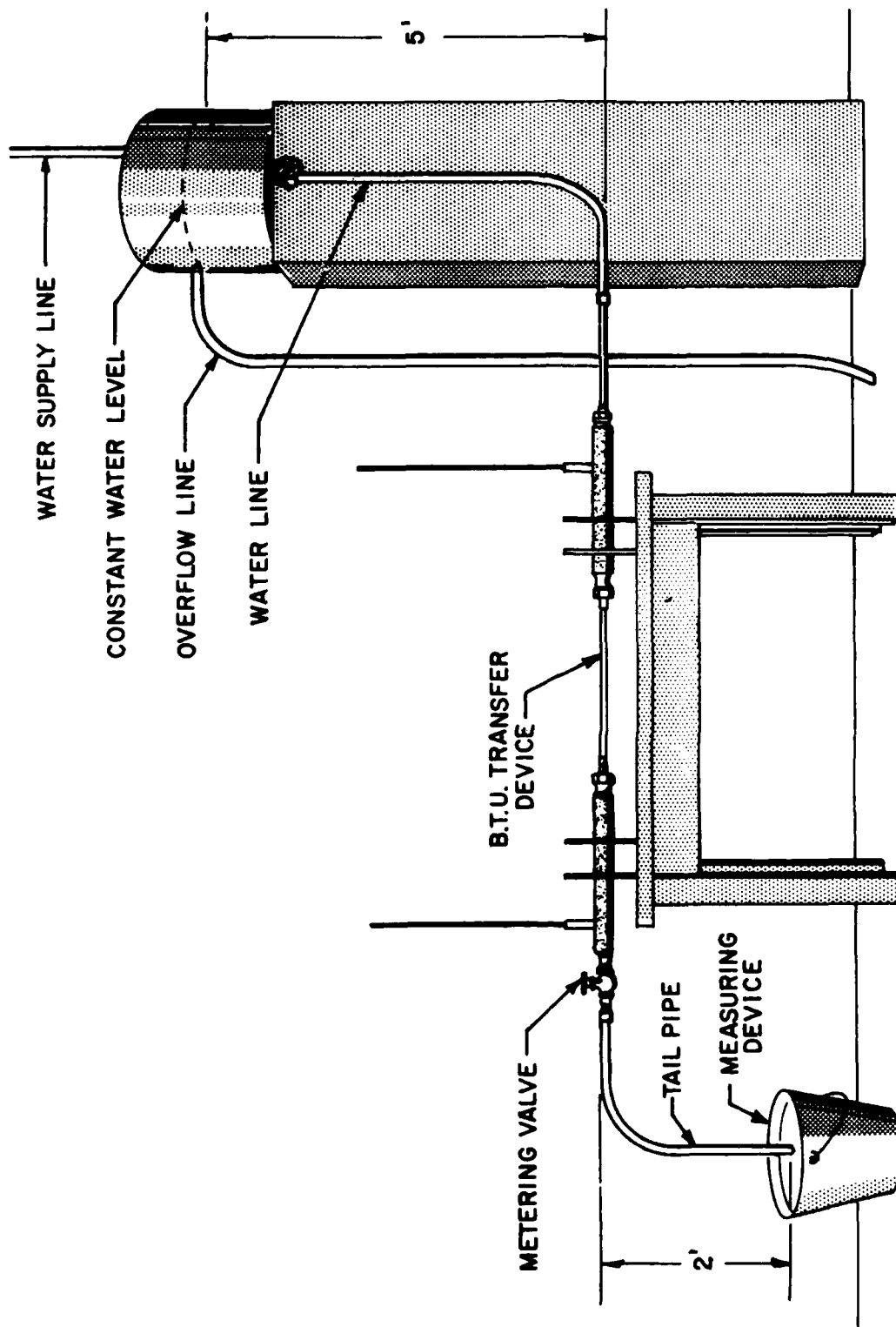
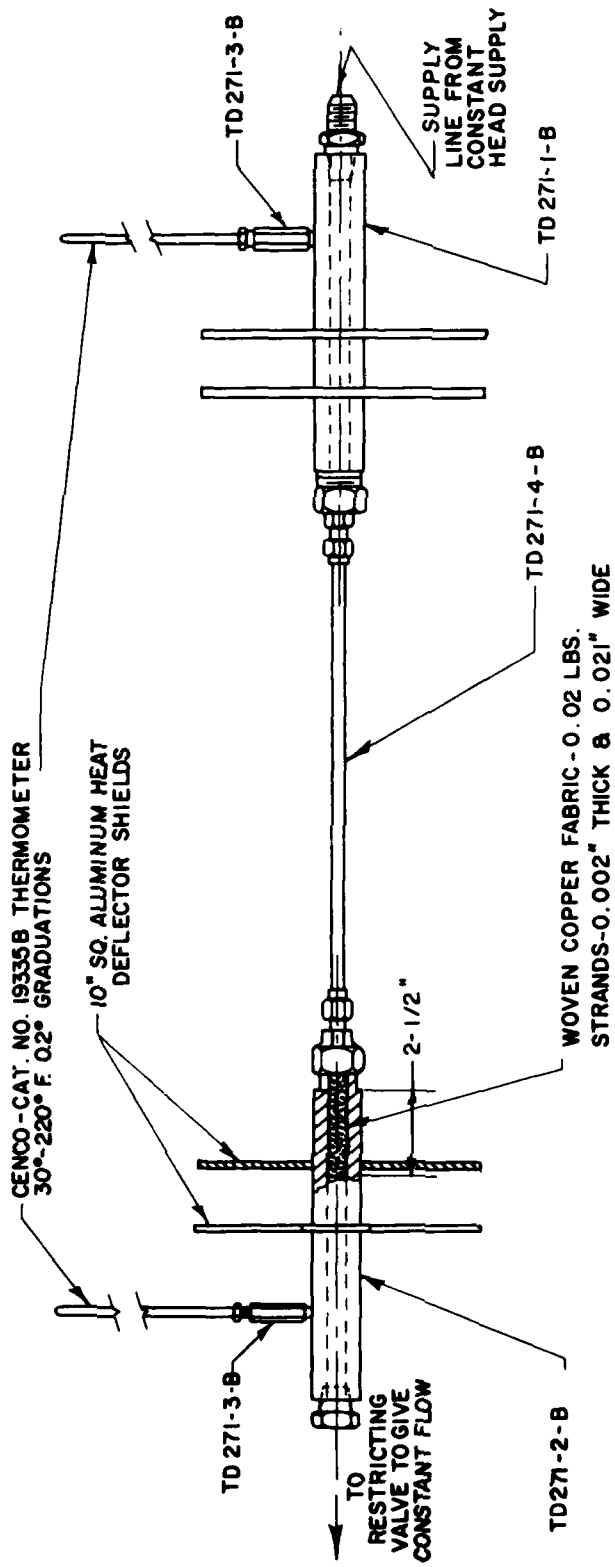

FIGURE 3. BURNER STANDARDIZATION APPARATUS



**ASSEMBLY**

**B.T.U. TRANSFER DEVICE FOR  
TORCH STANDARDIZATION**

Civil Aeronautics Administration  
Technical Development and Evaluation Center  
Indianapolis, Ind.

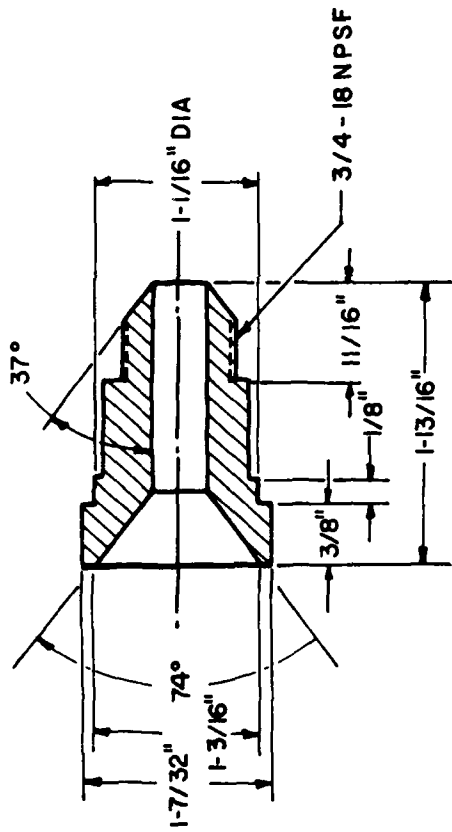
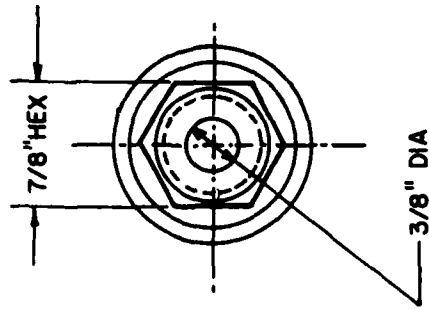

**REDUCER**

**B.T.U. TRANSFER DEVICE FOR  
TORCH STANDARDIZATION**

Civil Aeronautics Administration  
Technical Development and Evaluation Center  
Indianapolis, Ind.

**2 REQUIRED**  
**MATL. — BRASS**

MATL. — DILECTO ASBESTOS BASE TUBING, AA-79  
 Made by Continental-Diamond Fibre Corp., Newark, Del.  
 1 7/16" O.D. x 13/16" I.D. x 12"

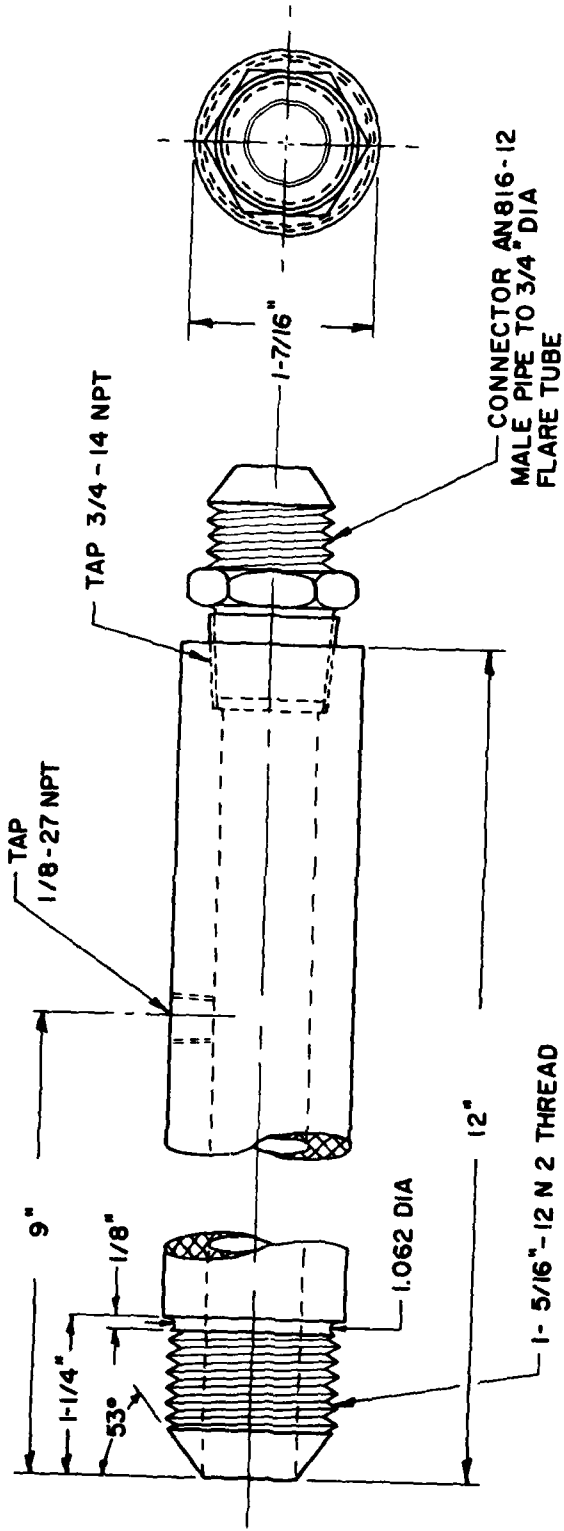

**INLET TUBE**  
**B.T.U. TRANSFER DEVICE FOR**  
**TORCH STANDARDIZATION**

Civil Aeronautics Administration  
 Technical Development and Evaluation Center  
 Indianapolis, Ind.

MATL. — DILECTO ASBESTOS BASE TUBING, AA-79  
 Made by Continental-Diamond Fiber Corp., Newark, Del.  
 1 7/16" O.D. x 13/16" I.D. x 12"

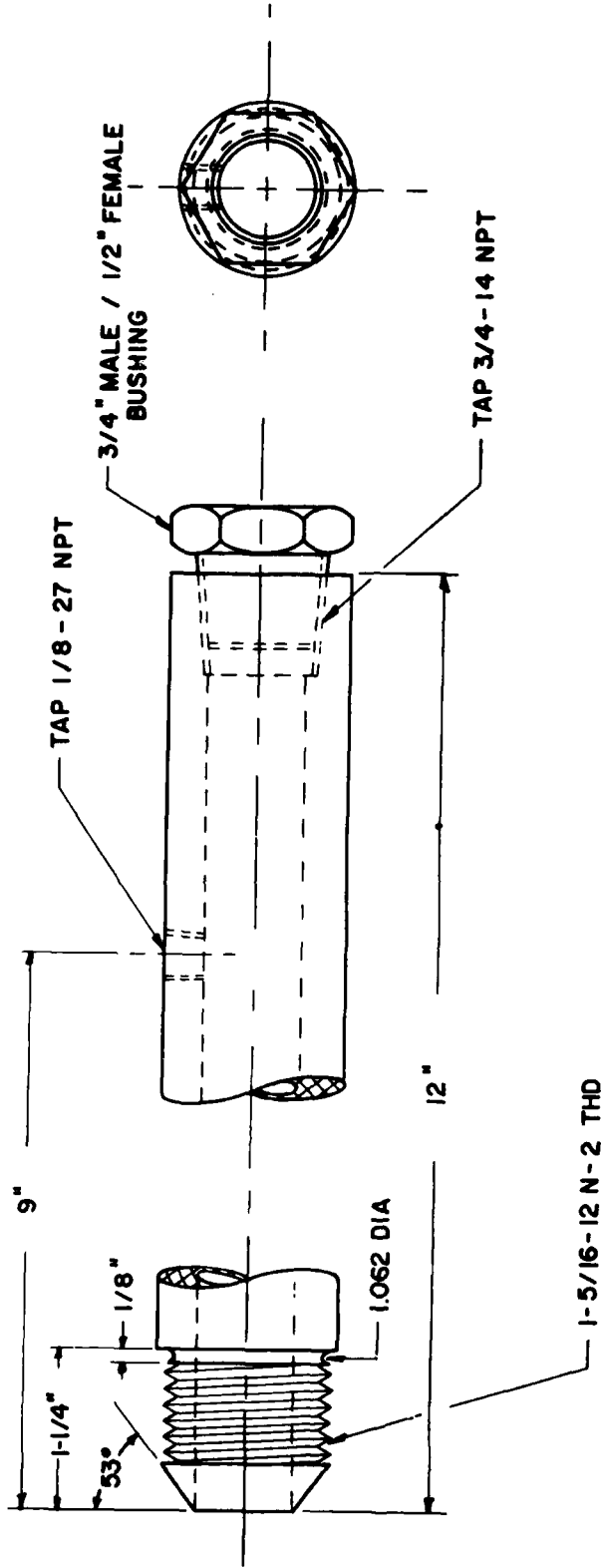

**OUTLET TUBE**

**B.T.U. TRANSFER DEVICE FOR  
 TORCH STANDARDIZATION**

Civil Aeronautics Administration  
 Technical Development and Evaluation Center  
 Indianapolis, Ind.

2 REQUIRED

MATL. — BRASS, 9/16" HEX. x 3 3/4"

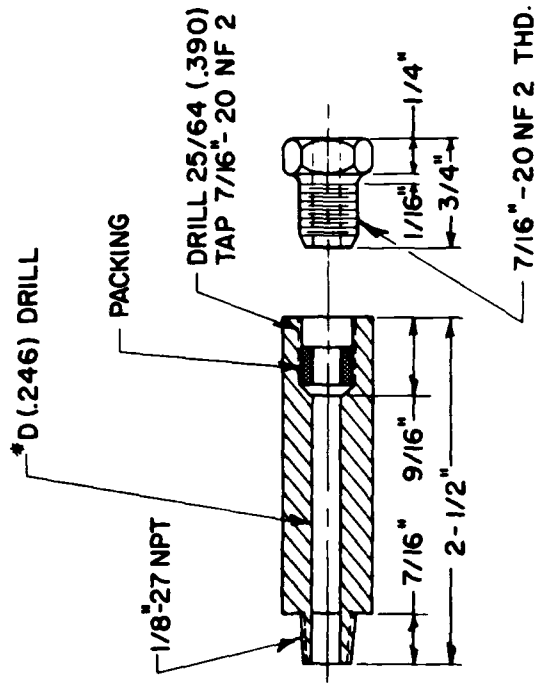

**THERMOMETER MOUNTING  
B.T.U. TRANSFER DEVICE FOR  
TORCH STANDARDIZATION**

Civil Aeronautics Administration  
Technical Development and Evaluation Center  
Indianapolis, Ind.

Drawing No. TD271-3-B

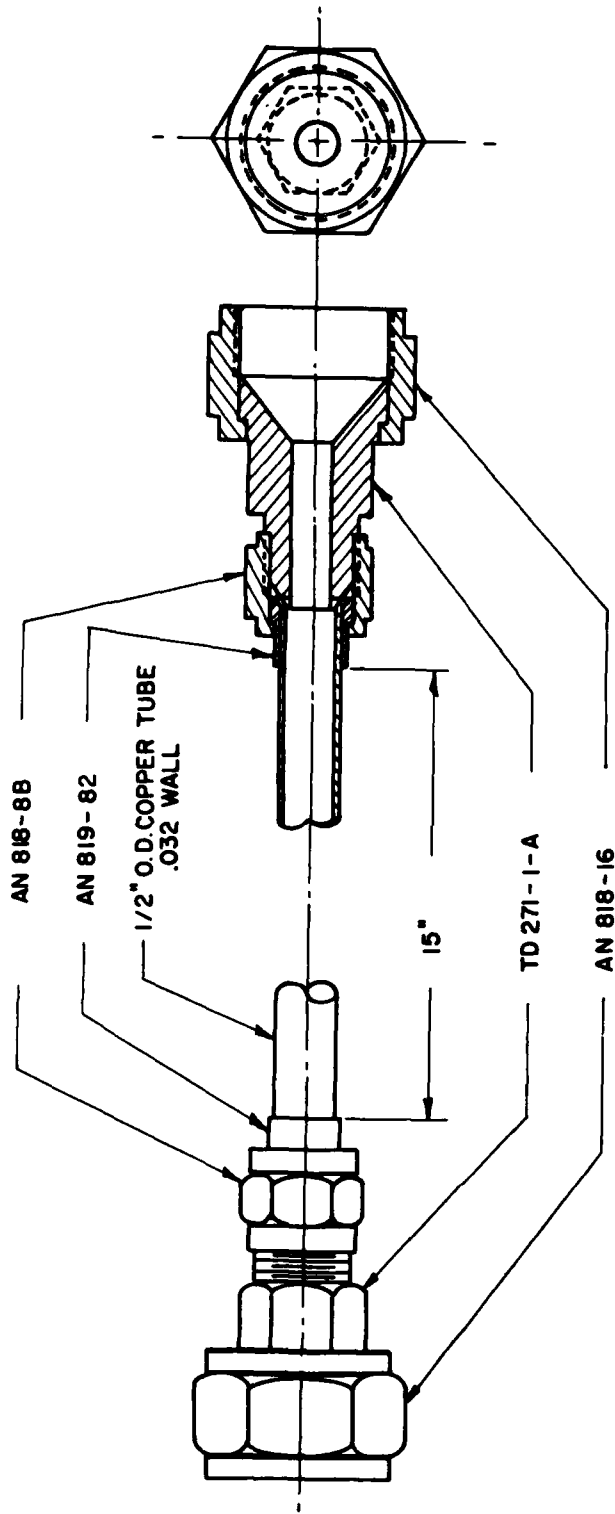

**TEST SPECIMEN**

**B.T.U. TRANSFER DEVICE FOR  
TORCH STANDARDIZATION**

Civil Aeronautics Administration  
Technical Development and Evaluation Center  
Indianapolis, Ind.

APPENDIX III  
Criteria/Qualified Burners

The burner originally specified in this report was a modified Lennox OB-32 which is no longer commercially available. Therefore, it has been necessary to establish criteria for testing to determine what currently available equipment meets the desired requirements. The flame characteristics of the modified Lennox OB-32 burner have been determined and these data were used to evaluate candidate burners (reference 1). The following information on the flame characteristics and acceptable burners was obtained from reference 1:

A. Controlling Characteristics of Flame:

1. Temperature measurements through the horizontal center-line should indicate 2,000  $\pm 150^{\circ}\text{F}$  for a distance of not less than 7 inches as measured with thermocouples described.
2. Total heat transfer to the 1/2-inch tube should not be less than 4,500 B.t.u./hr nor greater than 4,650 B.t.u./hr.
3. The total thermal energy as indicated by the calorimeter should average between 9.8 (+1.5/-0.5) to 10.8 (+1.0) B.t.u./ft<sup>2</sup>/sec.

Refer to figure 4 for the modified Lennox OB-32 temperature profile.

B. Acceptable Modified Burners:

CARLIN 200 CRD, manufactured by the Carlin Company, 912 Silas Deane Highway, Wethersfield, Connecticut 06109, shown in figures 5 and 6, was modified in the following manner to produce a diffused 6-inch (vertical) by 11-inch (horizontal) sized flame with homogeneous temperature gradient. Note: Carlin 200 CRD AS 1055 incorporates these following modifications and may be purchased directly.

1. An 80 fuel nozzle rated at 2.25 gal/hr. and pressure adjusted to deliver 2.04 gal/hr. at 97 psig was installed.
2. The retention and throttle rings plus the support and forward extension were removed.
3. A flat-plate disc, approximately 4 inches in diameter and randomly punched with ten 1/2-inch holes, was installed 4 inches aft of the fuel nozzle tip. This provided support and centering of the oil delivery tube.

4. The air tube diameter was decreased to 2 1/2 inches starting 1 1/2 inches forward of the fuel nozzle tip. The reducing cone is shown in figure 7.

5. Two 1/16-inch-thick by 3/4-inch-wide stainless steel fuel deflectors were installed at the 3 and 9 o'clock positions with their ends 5/8-inch from the fuel nozzle centerline and 3/4-inch forward of the fuel nozzle tip. A 1-inch wide stainless steel fuel deflector (1/16-inch thick) was installed at the 12 o'clock position with its edge 3/4 inch forward of the fuel nozzle tip and 3/4-inch above fuel nozzle centerline.

6. A static pressure port was installed 1-inch forward of the air tube mounting flange.

7. A 12 1/2-inch burner extension (reference 1) shown in figure 8 was added to the end of the burner air tube. The extension was installed on the air tube so that the wide end was 10 inches beyond the end of the air tube. The air pressure was adjusted to indicate 0.37 inch H<sub>2</sub>O air tube pressure.

The temperature profile obtained with this burner configuration is shown in figure 9. A heat transfer rate of 4,545 B.t.u./hr. to the 1/2-inch tube was obtained as shown in table 1, and the total thermal energy measured an average range from 9.3 to 11.2 B.t.u./ft /sec. Oxygen volumetric concentration within the flame ranged from 6.5 percent to 8.5 percent.

STEWART-WARNER MODEL HPR 250, manufactured by the Stewart-Warner Corporation, Heating and Air Conditioning Division, Lebanon, Indiana 46052, figures 10 and 11, was modified in the following manner to produce a diffused 6-inch (vertical) by 11-inch (horizontal) size flame with homogeneous temperature gradient:

1. An 80 fuel nozzle rated at 2.25 gal/hr. and pressure adjusted to 95 psig and delivering 2.04 gal/hr. was installed.
2. The air cone assembly was removed.
3. The air tube diameter was reduced to 2 1/2 inches starting 1 1/2 inches forward of the fuel nozzle tip with the addition of the reducing cone shown in figure 7.

4. Four 1/16-inch by 3/4-inch stainless steel fuel deflectors were mounted on the reducing cone at 3, 6, 9 and 12 o'clock positions. The deflector edges were 3/4-inch from the fuel nozzle centerline and 3/4-inch forward of the fuel nozzle tip.

5. A static air-pressure port was installed 1-inch forward of the burner tube mounting flange.

6. A 12 1/2-inch burner extension (reference 1) shown in figure 8 was added to the end of the burner air tube. The extension was installed so that the wide end was 10 inches from beyond the end of the air tube. Air pressure in the tube was adjusted to 0.14 inch H<sub>2</sub>O.

The temperature profile shown in figure 12 was obtained with this configuration, and a heat transfer rate of 4,646 B. t. u. /hr. to the 1/2-inch tube was obtained as shown in table 1. The total thermal energy measured an average range from 9.3 to 10.1 B. t. u. /ft<sup>2</sup>/sec. The O<sub>2</sub> concentration, measured through the horizontal centerline of the flame, fluctuated from 9.2 percent to 9.5 percent in the flame center. Two inches from each side, the O<sub>2</sub> concentration increased to 11 percent and 15 percent, respectively. This burner had the tendency to burn richer at the outer edges of the flame, as observed visually and confirmed by O<sub>2</sub> concentration measurements.

STEWART-WARNER MODEL FR-600, as shown in figures 13 and 14, was modified in the following manner to produce a diffused 6-inch (vertical) by 11-inch (horizontal) size flame with homogeneous temperature gradient.

1. An 80° fuel nozzle rated at 2.25 gal/hr. and pressure adjusted to deliver 2.03 gal/hr. at 100 psig was installed.

2. The flame retention hood assembly was removed.

3. The air tube diameter was decreased to 2 1/2 inches starting 1 1/2 inches forward of fuel nozzle tip, with the reducing cone as shown in figure 7.

4. Four 1/16-inch by 3/4-inch stainless steel deflectors were mounted on the reducing cone at 3, 6, 9, and 12 o'clock positions. The deflector edges were adjusted to within 3/4-inch from the fuel nozzle centerline and 1 1/2-inch forward of the fuel nozzle.

5. A 12 1/2-inch burner extension (reference 1) shown in figure 8 was added to the end of the burner air tube.

The extension was installed so that the wide end was 10 inches beyond the end of the air tube. Air pressure in the tube was adjusted to 0.01-inch H<sub>2</sub>O. The static disc and the flame detector were not altered.

Temperature profile obtained with this configuration is shown in figure 15. A heat transfer rate of 4,466 B. t. u. /hr. to the 1/2-inch tube was obtained as shown in table 1. The total thermal energy measured an average range from 9.9 to 10.9 B. t. u. /ft<sub>2</sub>/sec. Volumetric O<sub>2</sub> concentrations within the flame ranged from 8.5 percent to 15.2 percent.

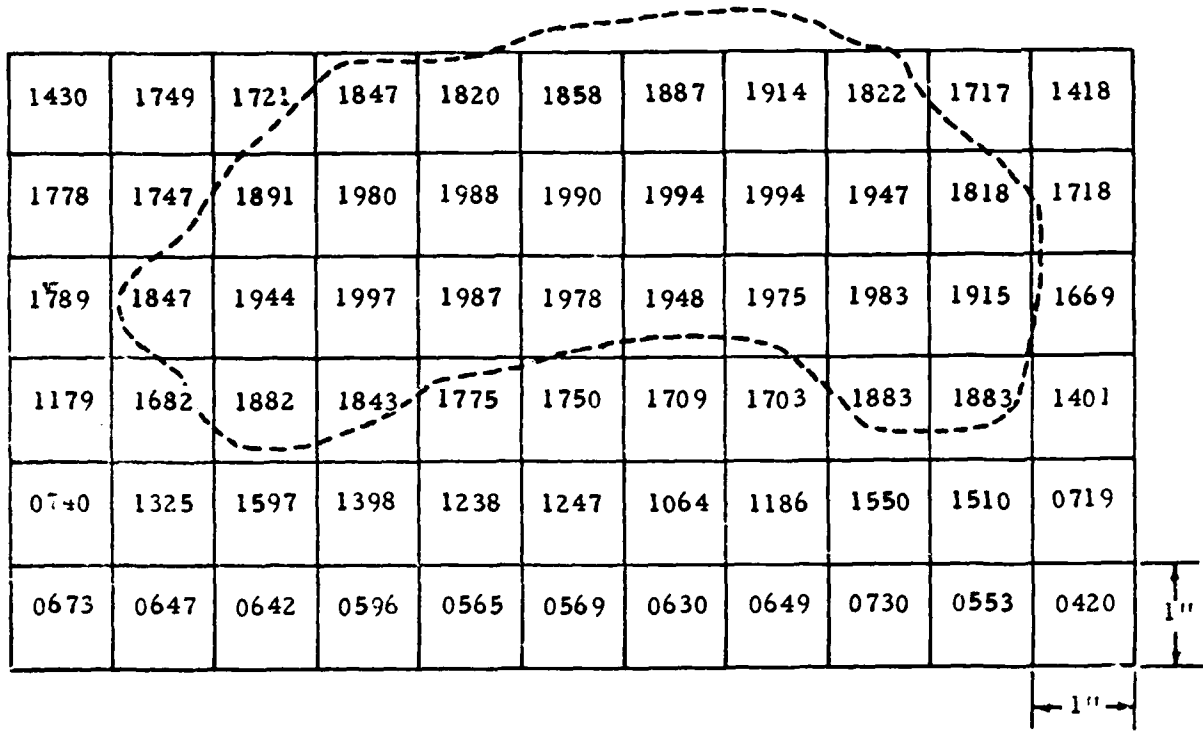

----- = 1800°F

FIGURE 4. LENNOX OB-32 TEMPERATURE PROFILE

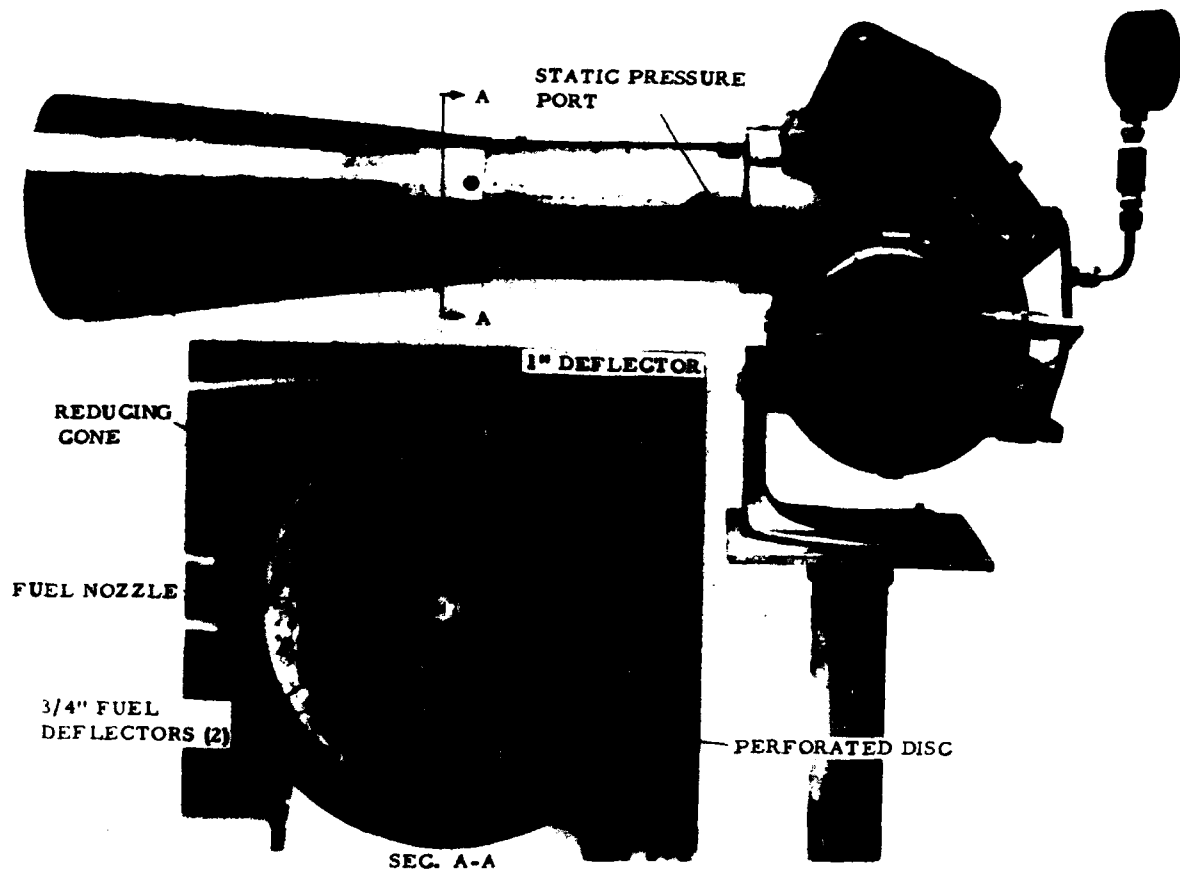

FIGURE 5. CARLIN 200 CRD CONVERSION OIL BURNER

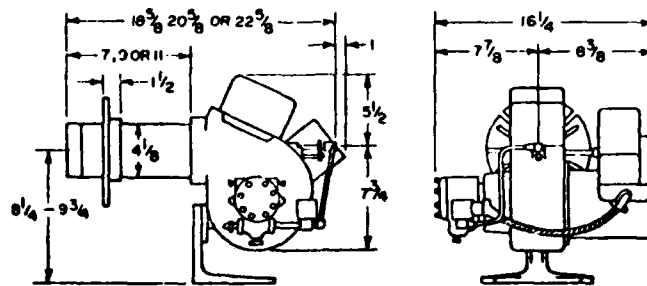
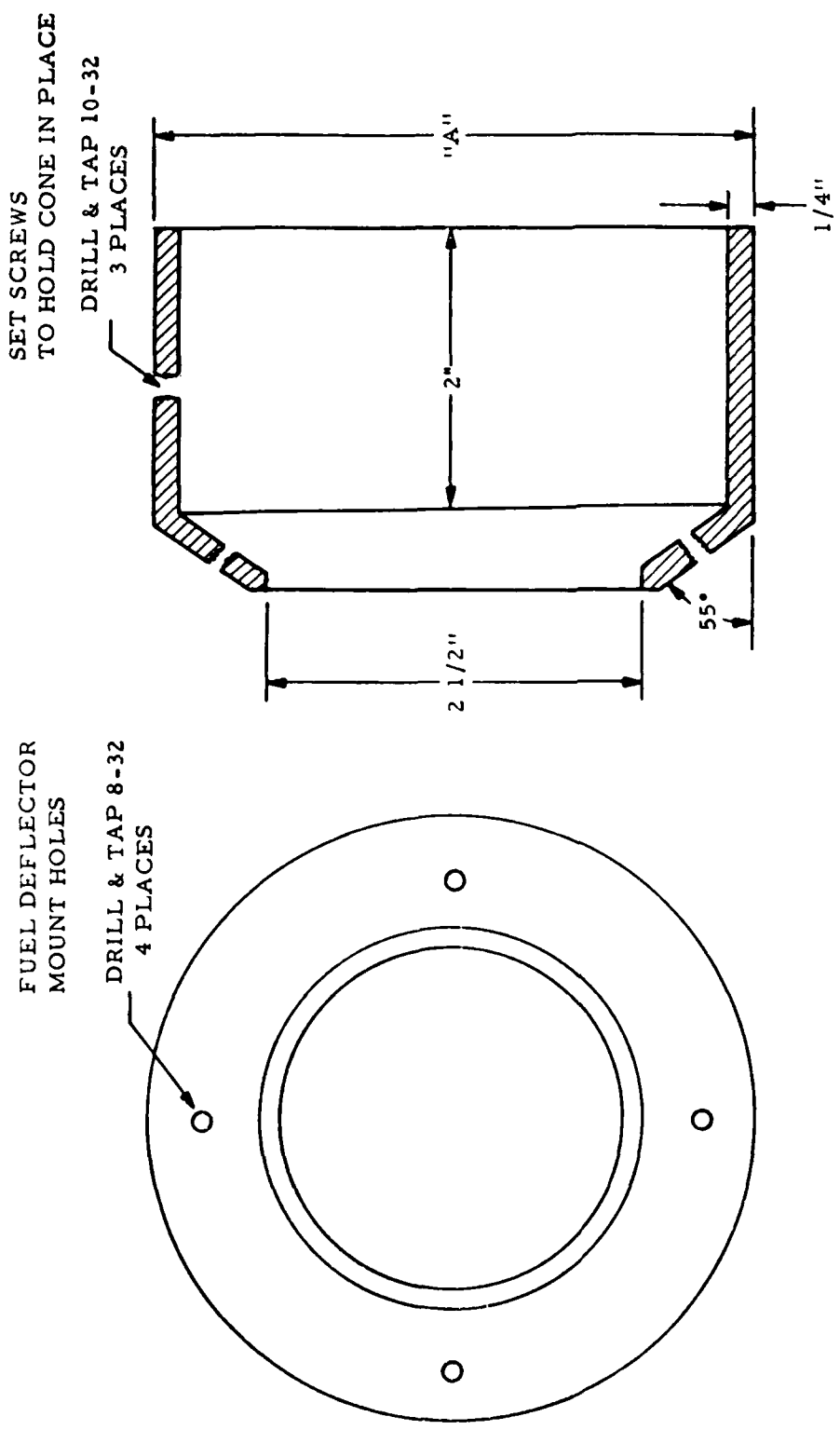

FIGURE 6. CARLIN 200 CRD BURNER



"A" = BURNER TUBE EXTENSION  
 INSIDE DIMENSION (")  
 MATERIAL: MILD STEEL

FIGURE 7. AIR TUBE REDUCING CONE

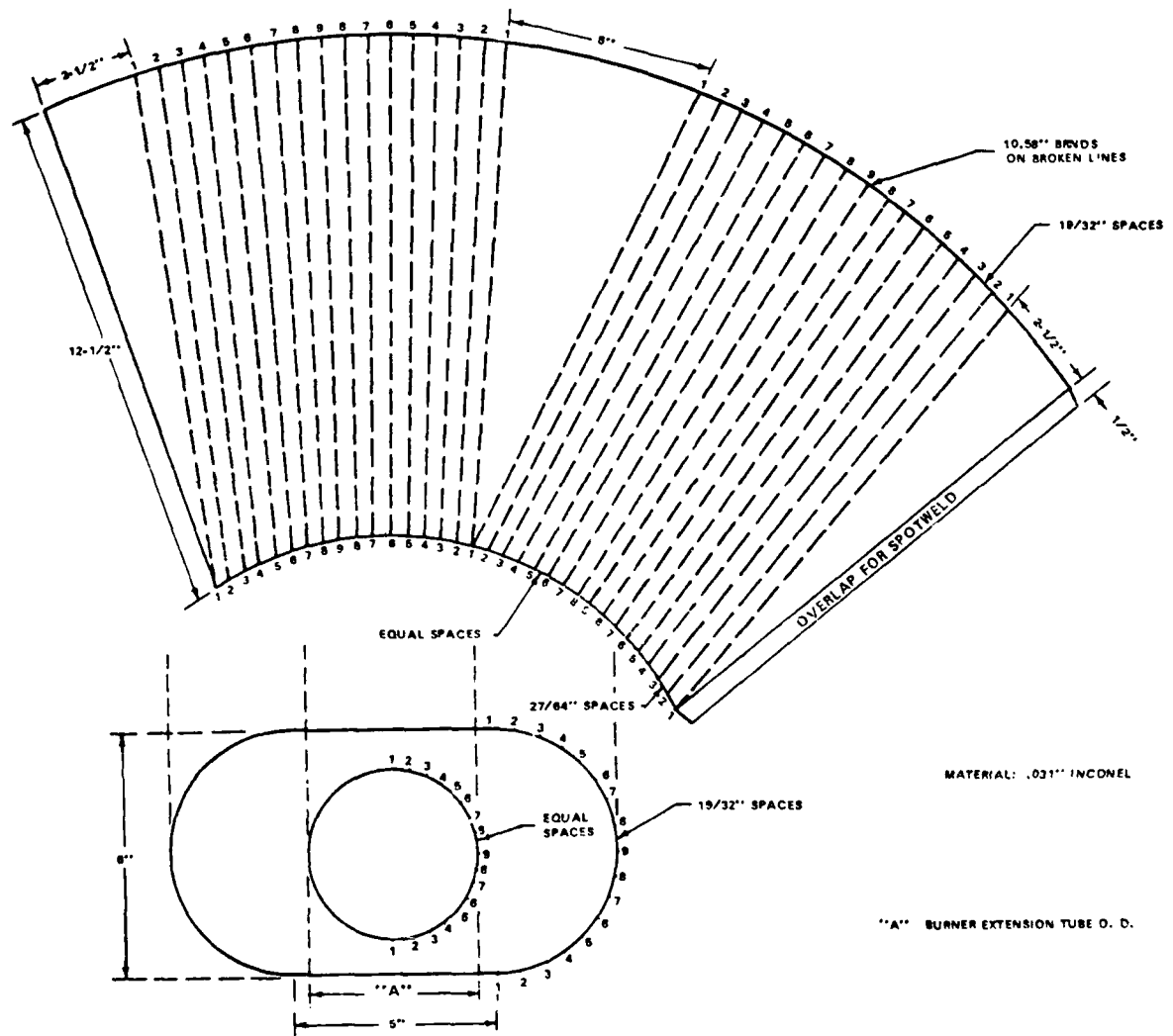

FIGURE 8. BURNER TUBE EXTENSION

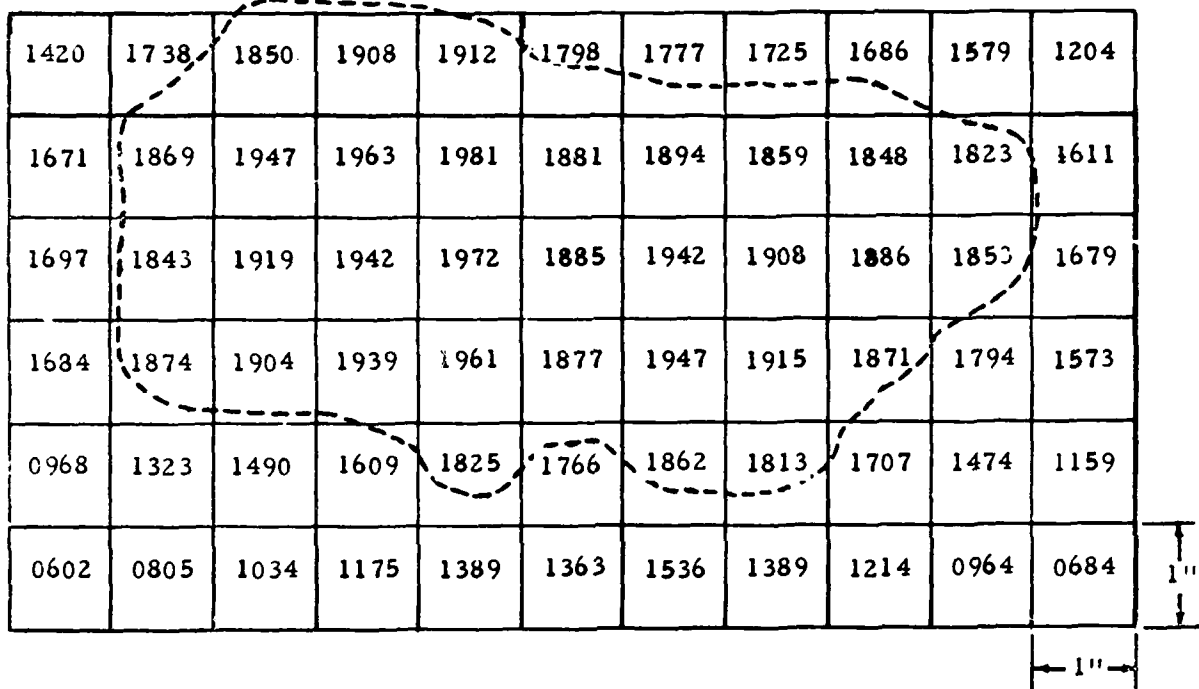

FIGURE 9. CARLIN 200 CRD TEMPERATURE PROFILE

<u>Burner</u>	<u>Rated Fuel Flow Capacity</u>	<u>Motor</u>	<u>Blower Wheel (inches)</u>	<u>Fuel Pump</u>	<u>Tube Extension (inches)</u>	<u>Heat Transfer to 1/2-in. Tube Btu/hr.</u>	<u>Total Thermal Energy (Btu/ft<sup>2</sup>/s)</u>	<u>Flame Oxygen Concentration (percent)</u>
Lennox OB-32	(Reference) only	1/4 hp 1,725 r/min.	3 5/8 x 6 1/8	Two Stage	4x12	4,574	9.8-10.8	5-11
Carlin 200 CRD	2.0-5.0 gal/hr.	1/4 hp 3,450 r/min.	3 1/2 x 5 1/4	Single Stage	4 1/8x11	4,545	9.3-11.2	6.5-8.5
Stewart Warner HPR-250	1.35-2.50 gal/hr.	1/7 hp 3,450 r/min.	3 9/16 x 5 3/8	Single Stage	4x13 5/32	4,646	9.3-10.1	9.2-9.5
Stewart Warner FR-600	2.0-6.0 gal/hr.	1/3 hp 3,450 r/min.	3 15/16 x 6 1/32	Two Stage	4x12 7/8	4,466	9.9-10.9	8.5-15.2

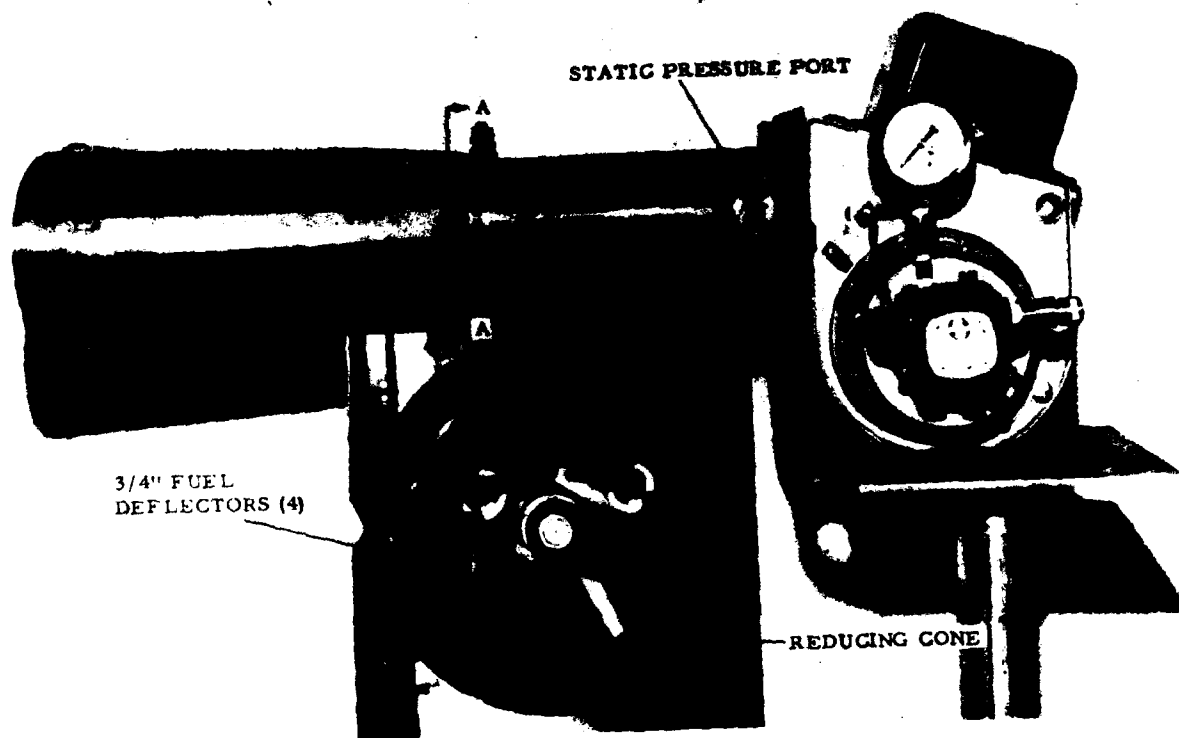

FIGURE 10. STEWART-WARNER HPR-250 CONVERSION OIL BURNER

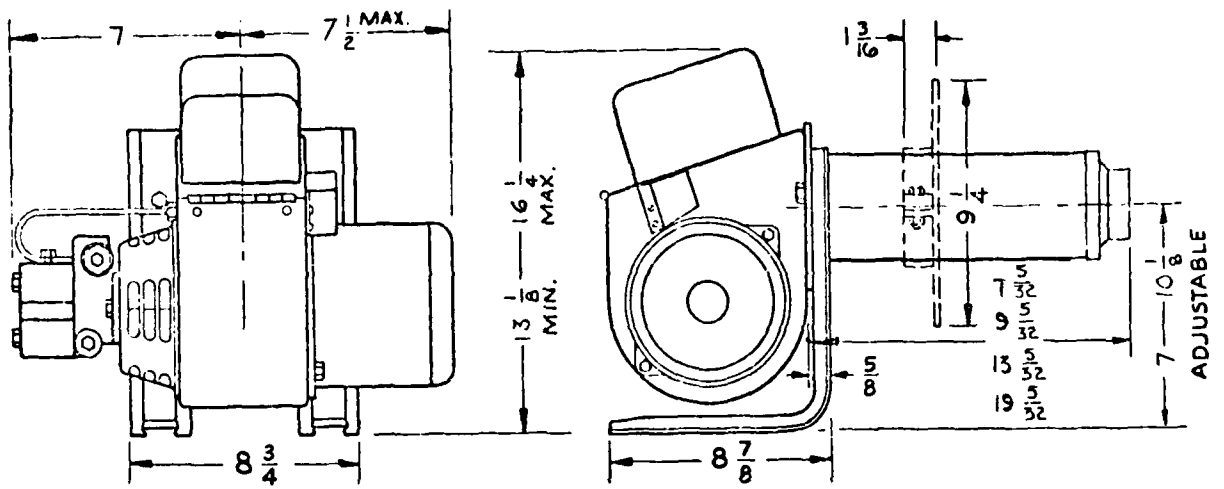

FIGURE II. STEWART-WARNER HPR-250 BURNER



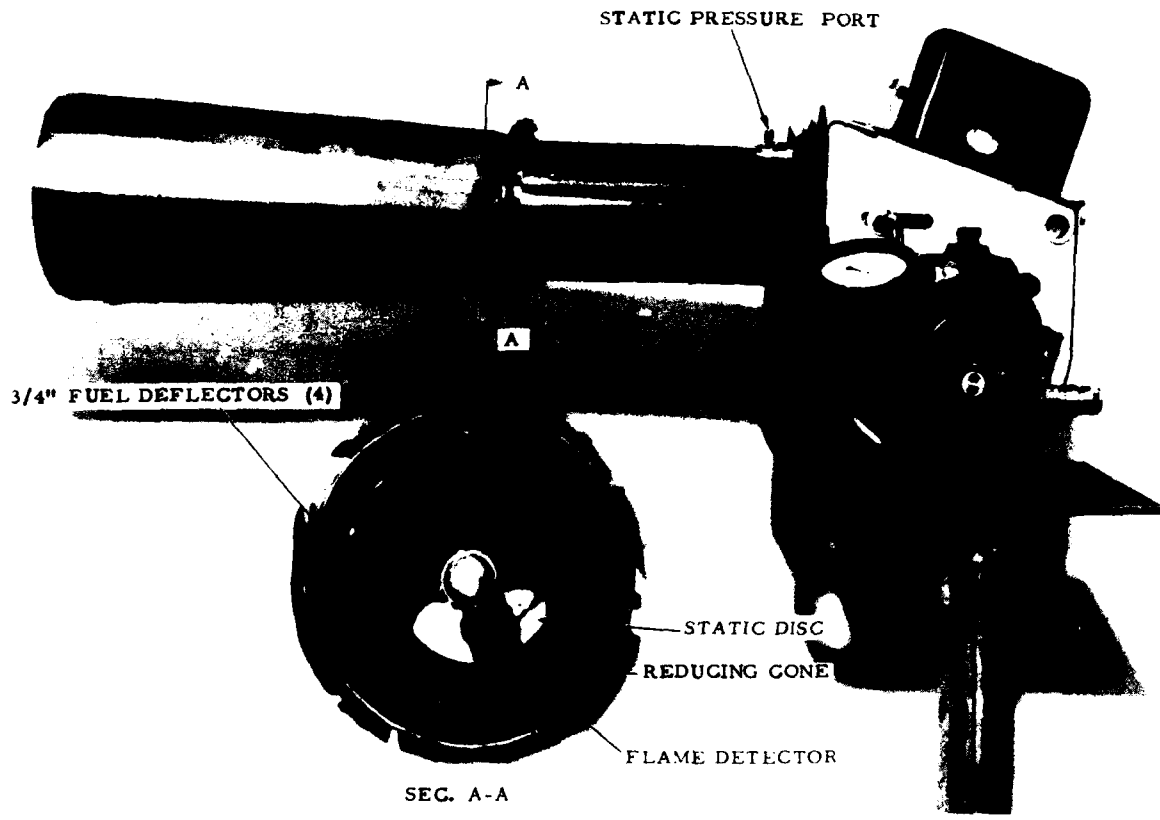

FIGURE 13. STEWART-WARNER FR-600 CONVERSION OIL BURNER

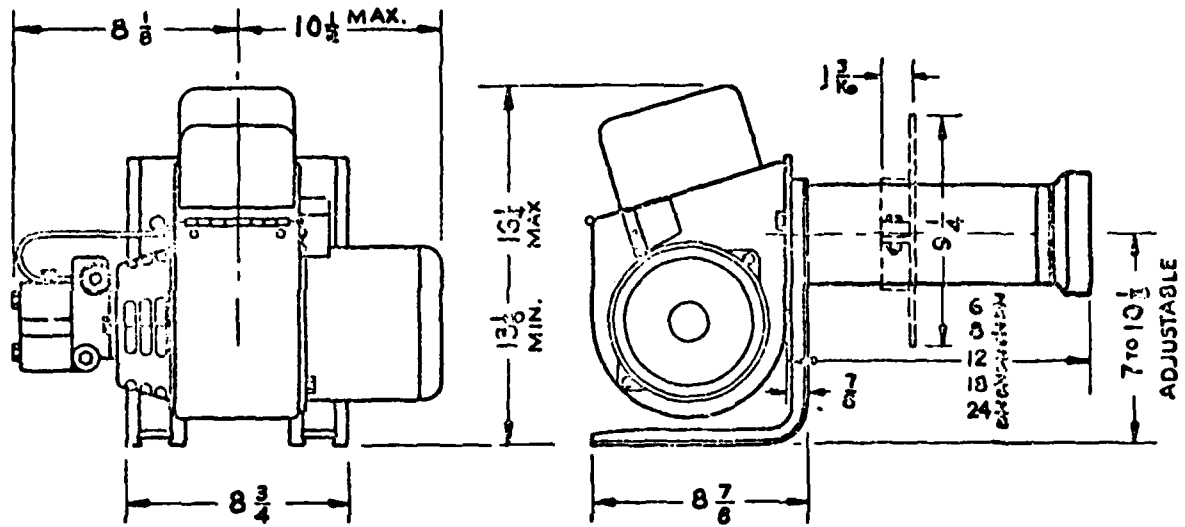

FIGURE 14. STEWART-WARNER FR-600 BURNER

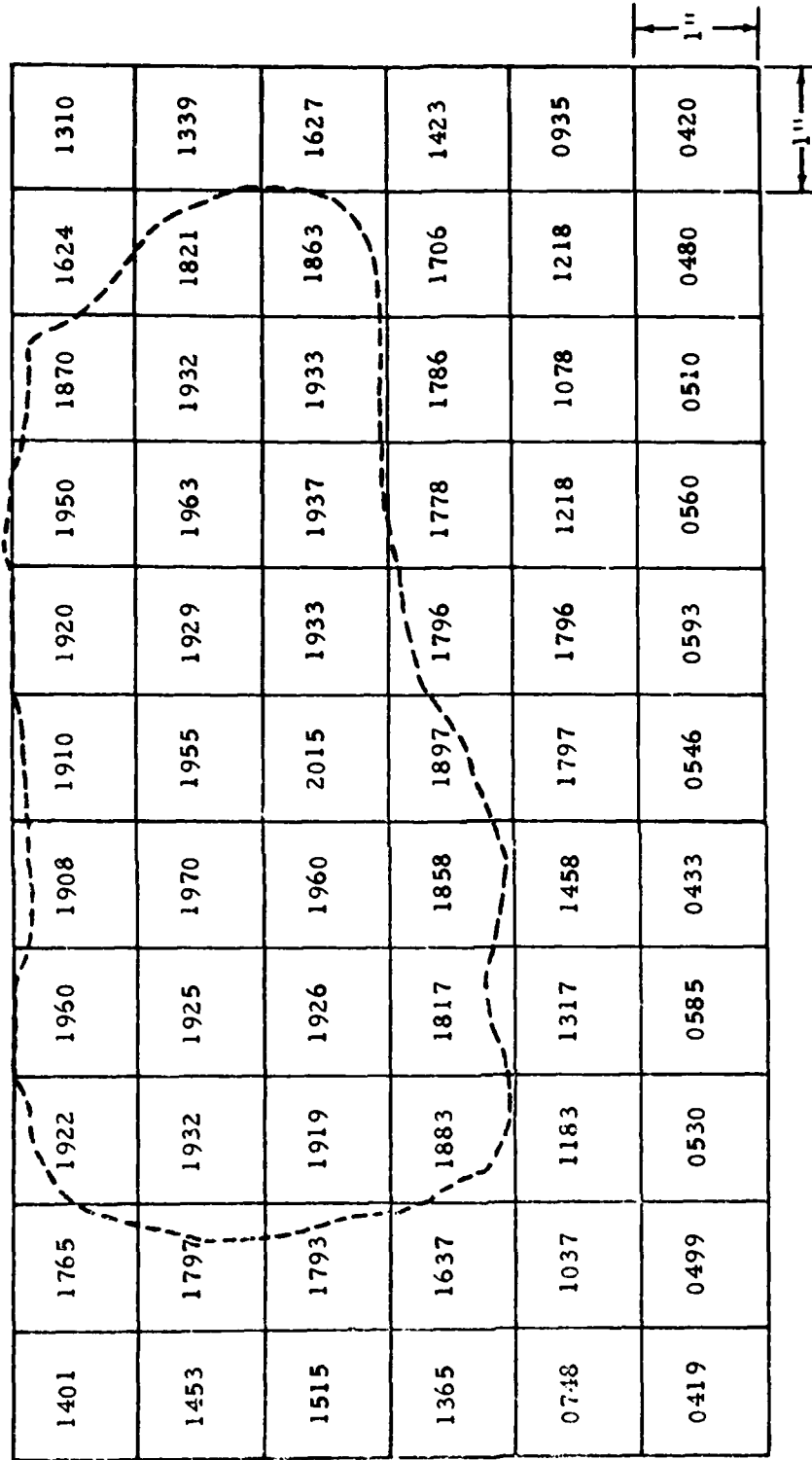

FIGURE 15. STEWART-WARNER FR-600 TEMPERATURE PROFILE

### Reference

1. Federal Aviation Administration: Report No. FAA-RD-76-213, Reevaluation of Burner Characteristics for Fire Resistance Tests, James E. Demaree, January 1977.
2. Society of Automotive Engineers: Report AS 1055B, Fire Testing of Flexible Hose, Tube Assemblies, Coils, Fittings and Similar System Components.
3. Society of Automotive Engineers: Report AS 1377, Fire Test Equipment for Flexible Hose and Tube Assemblies
4. Society of Automotive Engineers: Report G3-75-2, (SC10/DIS DDD), Fire Testing, Components, Fluid System, General Specifications for