

DTIC FILE COPY

2

NAVAL POSTGRADUATE SCHOOL Monterey, California

AD-A200 971



THESIS

DTIC
SELECTED
DEC 06 1988
S D
BE

DESIGN METHODOLOGY USING THE
GENESIL SILICON COMPILER

by

Robert Howard Settle

September 1988

Thesis Advisor: Herschel H. Loomis, Jr.

Approved for public release; distribution is unlimited

25

4

REPORT DOCUMENTATION PAGE

1a. REPORT SECURITY CLASSIFICATION UNCLASSIFIED		1b. RESTRICTIVE MARKINGS	
2a. SECURITY CLASSIFICATION AUTHORITY		3. DISTRIBUTION / AVAILABILITY OF REPORT	
2b. DECLASSIFICATION / DOWNGRADING SCHEDULE			
4. PERFORMING ORGANIZATION REPORT NUMBER(S)		5. MONITORING ORGANIZATION REPORT NUMBER(S)	
6a. NAME OF PERFORMING ORGANIZATION Naval Postgraduate School	6b. OFFICE SYMBOL (if applicable) 62	7a. NAME OF MONITORING ORGANIZATION Naval Postgraduate School	
6c. ADDRESS (City, State, and ZIP Code) Monterey, California 93943-5000		7b. ADDRESS (City, State, and ZIP Code) Monterey, California 93943-5000	
8a. NAME OF FUNDING / SPONSORING ORGANIZATION	8b. OFFICE SYMBOL (if applicable)	9. PROCUREMENT INSTRUMENT IDENTIFICATION NUMBER	
8c. ADDRESS (City, State, and ZIP Code)		10. SOURCE OF FUNDING NUMBERS	
		PROGRAM ELEMENT NO.	PROJECT NO.
		TASK NO.	WORK UNIT ACCESSION NO.
11. TITLE (Include Security Classification) DESIGN METHODOLOGY USING THE GENESIL SILICON COMPILER			
12. PERSONAL AUTHOR(S) SETTLE, Robert H.			
13a. TYPE OF REPORT Master's Thesis	13b. TIME COVERED FROM _____ TO _____	14. DATE OF REPORT (Year, Month, Day) September 1988	15. PAGE COUNT 182
16. SUPPLEMENTARY NOTATION The views expressed in this thesis are those of the author and do not reflect the official policy or position of the Department of Defense or the U.S. Government			
17. COSATI CODES		18. SUBJECT TERMS (Continue on reverse if necessary and identify by block number)	
FIELD	GROUP	Genesil Silicon Compiler design methodology; Custom 16 bit pipelined adder and multiplier performance; Top-down chip-design	
19. ABSTRACT (Continue on reverse if necessary and identify by block number) The applications of silicon compilers, and the design methodology of the Genesil Silicon Compiler are described. The performance of Genesil system library adders and multipliers are compared with comparable custom pipelined adder and multiplier circuits built on the Genesil Silicon Compiler. High performance pipeline methods are discussed. The appendix is a tutorial illustrating a Genesil system hierarchical top-down chip design, including simulation and timing analysis procedures.			
20. DISTRIBUTION / AVAILABILITY OF ABSTRACT <input checked="" type="checkbox"/> UNCLASSIFIED/UNLIMITED <input type="checkbox"/> SAME AS RPT <input type="checkbox"/> DTIC USERS		21. ABSTRACT SECURITY CLASSIFICATION UNCLASSIFIED	
22a. NAME OF RESPONSIBLE INDIVIDUAL LOOMIS, Herschel H. Jr.		22b. TELEPHONE (Include Area Code) 408-646-3124	22c. OFFICE SYMBOL 62Lm

Approved for public release; distribution is unlimited

Design Methodology Using the
Genesil Silicon Compiler

by

Robert Howard Settle
Lieutenant Colonel, United States Marine Corps
B.S., United States Naval Academy, 1971

Submitted in partial fulfillment of the
requirements for the degree of

MASTER OF SCIENCE IN ELECTRICAL ENGINEERING

from the

NAVAL POSTGRADUATE SCHOOL
September 1988

Author:

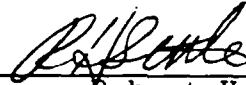

Robert Howard Settle

Approved by:

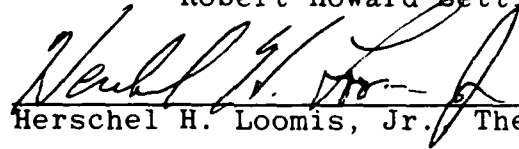

Herschel H. Loomis, Jr. Thesis Advisor



Chyan Yang, Second Reader



John P. Powers, Chairman
Department of
Electrical and Computer Engineering



Gordon E. Schacher
Dean of Science and Engineering

ABSTRACT

The applications of silicon compilers, and the design methodology of the Genesil Silicon Compiler are described. The performance of Genesil system library adders and multipliers are compared with comparable custom pipelined adder and multiplier circuits built on the Genesil Silicon Compiler. High performance pipeline methods are discussed. The appendix is a tutorial illustrating a Genesil system hierarchical top-down chip design, including simulation and timing analysis procedures.

Accession For	
NTIS GRA&I	<input checked="" type="checkbox"/>
DTIC TAB	<input type="checkbox"/>
Unannounced	<input type="checkbox"/>
Justification	
By _____	
Distribution/	
Availability Codes	
Dist	Avail and/or Special
A-1	



TABLE OF CONTENTS

I.	INTRODUCTION.....	1
II.	GENESIL SILICON COMPILER.....	5
	A. INTRODUCTION.....	5
	B. ASIC DESIGN.....	5
	C. GENESIL SYSTEM DESCRIPTION.....	6
III.	ADDER CIRCUITS.....	23
	A. PIPELINED CIRCUITS FOR HIGH PERFORMANCE.....	23
	B. FULL ADDER DESIGN.....	24
	C. FOUR BIT ADDER DESIGN.....	32
	D. SIXTEEN BIT ADDER DESIGN.....	41
	E. PERFORMANCE SUMMARY.....	61
IV.	MULTIPLIER CIRCUITS.....	62
	A. INTRODUCTION.....	62
	B. 4, 8, AND 16 BIT GENESIL LIBRARY MULTIPLIER.....	64
	C. 4 BIT PIPELINED MULTIPLIER.....	68
	D. 16 BIT PIPELINED MULTIPLIER.....	75
V.	CONCLUSIONS.....	82
	A. SUMMARY.....	82
	B. RECOMMENDATIONS.....	83
	APPENDIX.....	84
	LIST OF REFERENCES.....	174
	INITIAL DISTRIBUTION LIST.....	176

I. INTRODUCTION

As integrated circuits (I.C.) grow increasingly complex, new methods are needed to manage the complexity, cost, and time consumed when designing and testing the desired I.C. system. There is a demand for a quick, and relatively economical design process to precede the actual chip layout. To meet this criteria, the methodology must have the capability of design at higher levels to specify, design, and simulate the desired circuit. A state-of-the-art solution to this requirement is the silicon compiler.

Loosely defined, a silicon compiler is a system which generates I.C. layouts from high-level descriptions. Originally, silicon compilation referred to a design methodology in lieu of a system or set of processes. The silicon compiler was analogous to compilation of machine code from a high-level language. An object was a graphic image rather than a block of executable code. Geometrics of the desired chip were constructed the same way as machine code, i.e., compiled from high-level languages. Early silicon compilers use "C" and "LISP" compilers. [Ref. 1]

The latest silicon compilers are complete design systems. Compilation is used as one mechanism for overall chip design. State-of-the-art silicon compilers have computer aided engineering (CAE) / computer aided design (CAD) as in the past, but also include geometry editing, symbolic editing,

simulation, automatic placement, automatic routing, compaction, and design rule checking [Ref. 1].

Each state of a complex custom I.C. system design, from concept to silicon testing, requires a team of experts in each field. Each team normally is not an expert in the other areas of chip development. Team expertise is a necessary condition in the fields of requirements generation, logic implementation, circuit simulation, chip layout, and testing. Chip level silicon compilation now allows a systems engineering to design Very Large Scale Integrated (VLSI) chips. With a silicon compiler, the design is accomplished by using a top-down, hierarchical design methodology starting with a partitioned chip set, proceeding down to individual chips, modules, and finally blocks. The blocks, or bottom-level design elements, include various types of logic blocks including ALU's, PLA's, RAM's, ROM's, multipliers, and inverters [Ref. 2].

Generally, far less time is required to design a circuit with a silicon compiler than is necessary for a comparable manual/CAD design method using graphic layout tools. The silicon compiler makes possible the rapid, real time development and testing of a system. This is advantageous for designing and producing relatively small numbers of chips. This is especially attractive for military applications where small numbers of chips are required (hundreds and thousands vs. millions) and a rapid turnaround time is desired [Ref. 3].

Reference [1] contains a directory with capability comparisons of the silicon compilers currently available from commercial sources. The most notable systems observed in the directory concerning flexibility and overall performance were the Concorde Silicon Compiler, made by the Seattle Silicon Corp. and the Genesil Silicon Compiler produced by Silicon Compiler Corp.

Currently, the Naval Postgraduate School has the capability of VLSI design using full custom methods, the MacPitts Silicon Compiler, and the Genesil Silicon Compiler. Both the full custom and MacPitts methods depend on separate, time consuming, programming for simulation and timing analysis of a VLSI chip. In Genesil, simulation and timing analysis are integrated into the system.

Chapter II describes the Genesil System's stand alone capabilities for the design of a VLSI system. Chapter III briefly describes system pipelining theory, a comparison of Genesil library versus custom adders, followed by the design and performance results of a pipelined 16 bit adder built on the Genesil Silicon Compiler. Chapter IV contains performance comparisons of Genesil library multipliers versus custom multipliers, followed by the design and performance results of a custom 4 bit pipelined Wallace Tree structured multiplier, concluding with the design and performance results of a custom

pipelined 16 bit parallel multiplier. The Appendix contains a tutorial for a top-down VLSI chip design for the Genesis Silicon Compiler.

II. GENESIL SILICON COMPILER

A. INTRODUCTION

The Genesil Silicon Compiler is based on silicon compilation, which is an Application Specific Integrated Circuit (ASIC) design method. ASIC design methodology also includes full custom, gate array, and standard cell methods. Full custom design is accomplished by a team of IC experts, whereas gate array, standard cell, and silicon compilation are based on the premise that the designer is not an IC expert [Ref. 4].

B. ASIC DESIGN:

Full custom design is normally used by IC manufacturers producing vast quantities (millions) of standard off-the-shelf type chips, such as microprocessors. The chip is normally very dense with a full set of masks and customized probe cards for production tests since the designer and user are most likely not the same [Ref. 2]. Full custom design is time consuming and expensive, which can be attributed to the complexity of the design parameters for high density chips. Design parameters, at the full custom level, are a constant tradeoff involving performance (speed, power, function), die size, ease of test generation, and testability [Ref. 5].

Gate array design is accomplished by interconnecting the appropriate rows and columns of transistors with metal layers defining the circuit from appropriate netlist libraries. The

array is prefabricated and a circuit design is "fitted" to the array. Processing time is low, but circuit density is also low. Gate array vendors provide macros containing predefined patterns to form SSI circuits such as NAND and NOR gates [Ref.4]. This presents problems when attempting to translate a high level specification from one vendor to another.

Standard cell design is based upon the same methodology as the gate array design except it differs in the manufacture cycle. The gate array is a pre-manufactured wafer to which metal is added to form the IC. The standard cell does not have pre-defined transistor locations. The manufacturing process is similar to full custom, requiring all layers to be created. This does result, however, in a more dense circuit than that produced by the gate array method.

Silicon compilation produces a circuit which is very similar to a full custom design by synthesizing the circuit with a top-down, hierarchical design methodology consisting of chip sets, individual chips, modules and blocks [Ref. 5]. Silicon compilation provides the interface between high level design specifications and a variety of design tools which produce efficient IC layouts.

C. GENESIL SYSTEM DESCRIPTION

The Genesil Silicon Compiler System is a design automation system which provides the user with the capability of designing VLSI circuits from high level system description to manufacture tapeout by producing the IC circuits from

architectural descriptions. The system is composed of menus, commands, and forms used in the following activities descriptions. The system uses the UNIX Operating System. A Genesil System Overview is shown in Figure 2.1 [Ref. 6:p. 2.3].

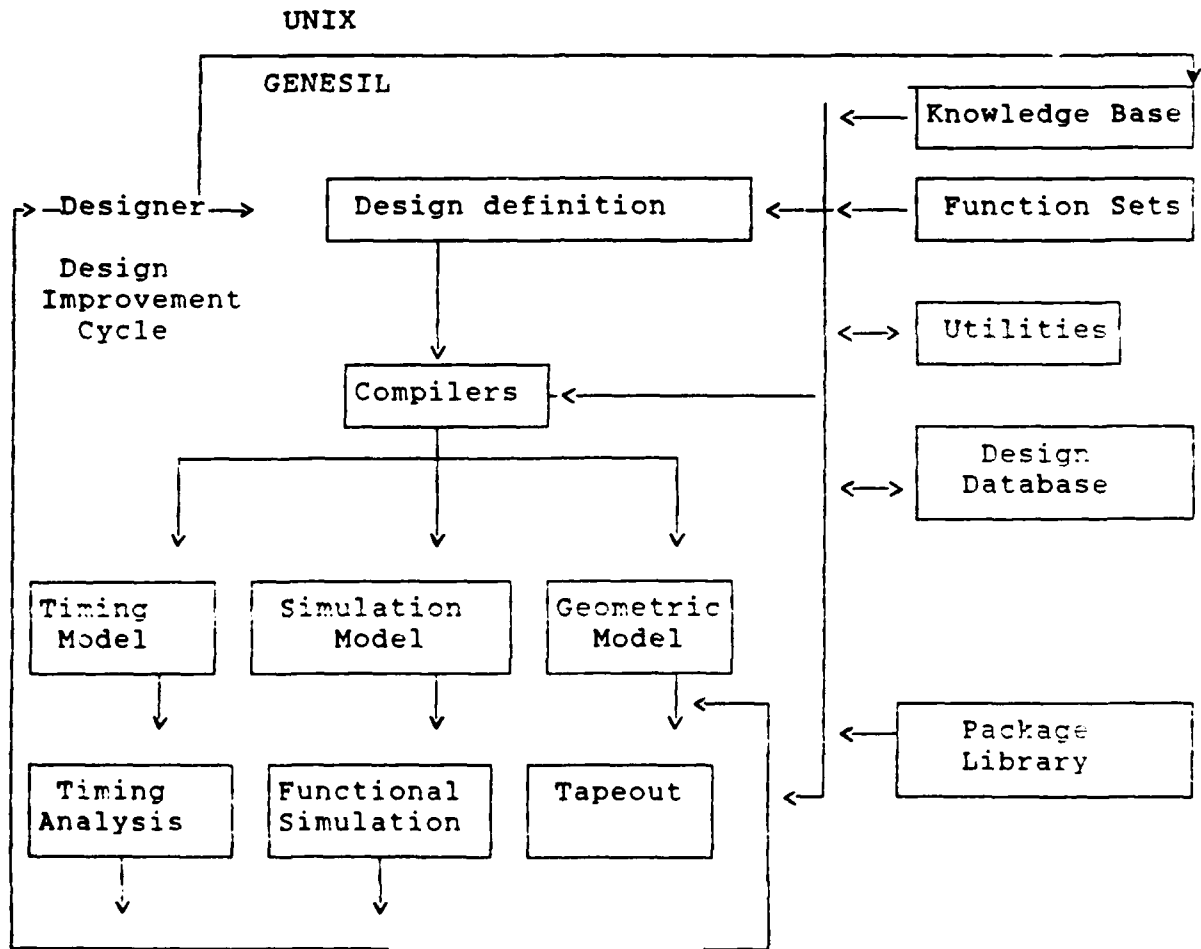

Figure 2.1 Genesil Overview

1. Methodology

Prior to beginning a Genesil session, the user should pre-plan all functional and performance specifications. With this initial plan, the user is able to rapidly observe exploratory ("first cut") designs of the required specifications. After as many alterations as desired or required, the detailed design can be completed to include simulation and timing analysis. Next, the physical design process is "invoked" by using the Floor planning feature. Once floor planned, verification is again conducted by functional simulation for logic, and timing analysis for performance. The chip is then ready for manufacture interface. The Genesil methodology is illustrated in Figure 2.2 [Ref. 6:p. 2.8].

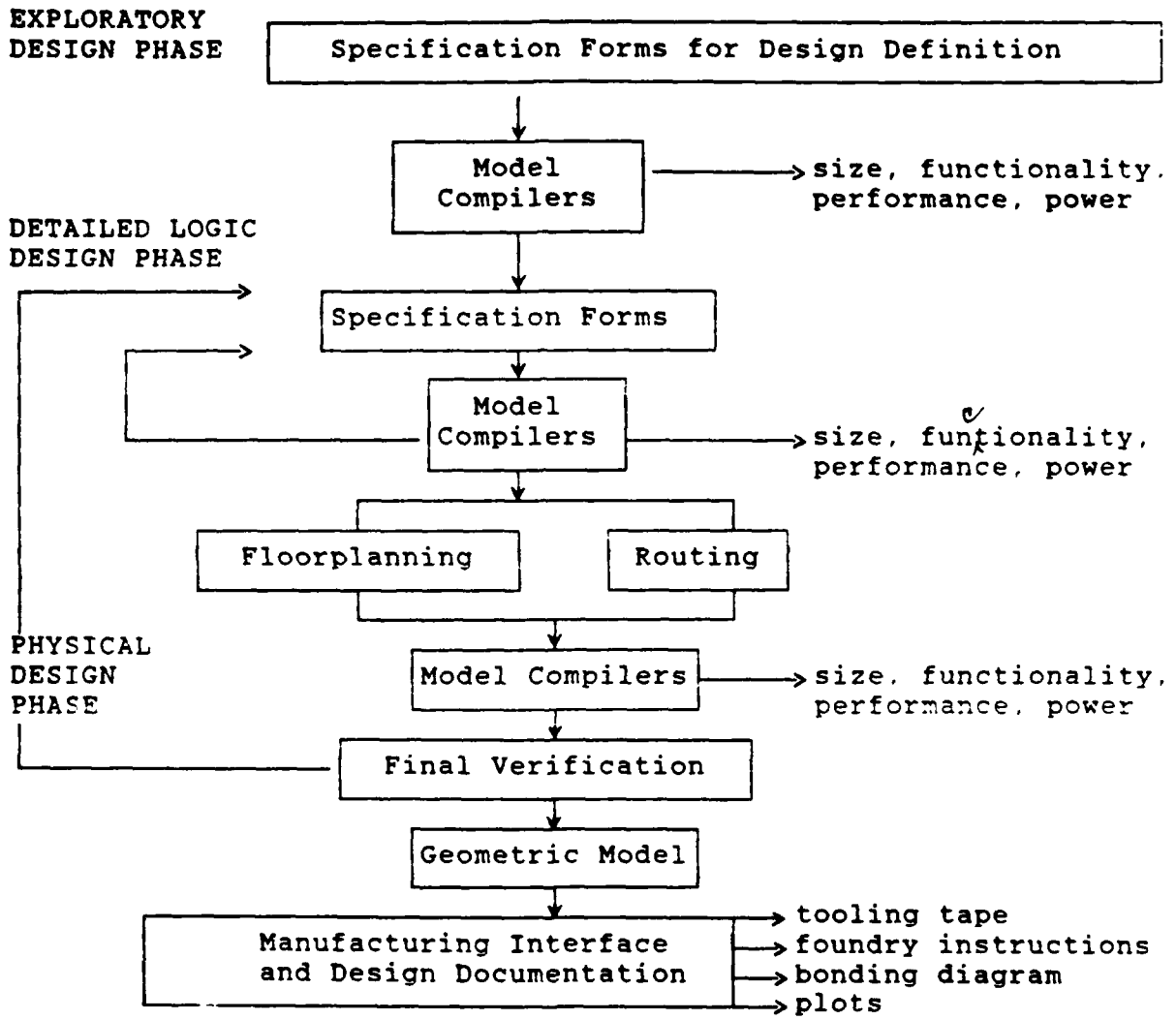

Figure 2.2 Genesil Methodology

2. Design

Genesil is an object oriented system which uses a hierarchical pathname system based on the UNIX operating system pathnames. Objects are selected, attached, detached, moved, and removed from the user's account. Objects include blocks, modules, chips, and chip-sets.

Blocks are the lowest level objects in the Genesil System object hierarchy. Blocks are created by the system block generator as directed by the user's functional specifications. There are three types of blocks, independent blocks, data-path blocks, and random logic blocks. Independent blocks include complex stand alone blocks of logic such as ROM's and PLA's. Data-path blocks are designed specifically for functions that manipulate parallel data. Random logic blocks contain user specified gate level logic. Modules are a collection of blocks, other modules (submodules), and parallel data-path modules [Ref. 7:p. 1.2].

Modules are intermediate objects in the hierarchy. Modules are a collection of blocks and other modules (submodules) [Ref. 7:p. 1.2].

Chips are complete integrated circuits. Chips contain blocks, modules, pad specifications, interconnection lists, positioning information for blocks and modules and packaging information. Chipsets are a collection of chips. Chipsets include chip interconnection lists, and user-supplied

simulation model programs and timing analysis models [Ref. 6:p. G.4].

After an object is attached from the SELECT_OBJECT menu, a Header Form is completed which specifies function type (i.e., RAMs, PLAs, random logic, etc.) and fabline. Next, a Specification Form is used to implement detailed information about the object. The Specification Form varies, depending on the object type selected. The Specification Form is the heart of the design process. This is where all design specifications are designated by the user. Functional objects are attached/detached, signals attached/detached, and bus widths designated. Once the Specification Form is completed to the user's specifications, the system generates a form check which identifies any incorrect signal connections which can be corrected immediately. Figure 2.3 [Ref. 6:p. 5.16] illustrates the design description hierarchy.

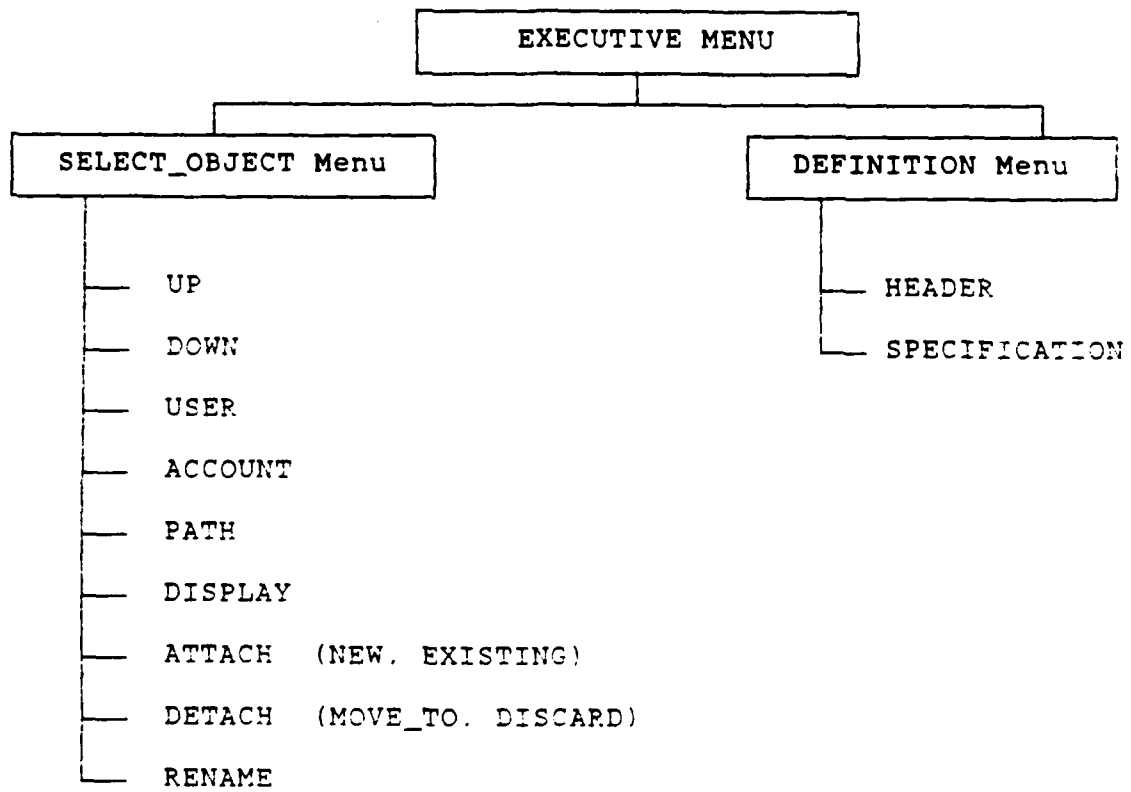

Figure 2.3 Design Description Hierarchy

3. Netlisting

A net is a connection between two or more objects. Objects are any one or combination of blocks, modules, chips, or chipsets. A netlist is a listing of all the nets in a module or chip. The netlisting feature allows the user to specify the interconnections between objects. Object-netlisting and Net-netlisting are two options which may be selected and show the same information from different points of reference. The Object-netlist form is used to define connections of sub-objects to the system net. The Net-netlist form is used to specify signal names to be combined into a network which the system creates. Used in this context, a signal is synonymous with a node, from which a single node is formed from all connectors and nets which are electrically equivalent. Netlisting can also be accomplished between chips to form chipsets. Figure 2.4 shows the netlisting commands hierarchy [Ref. 6:p. 6.18].

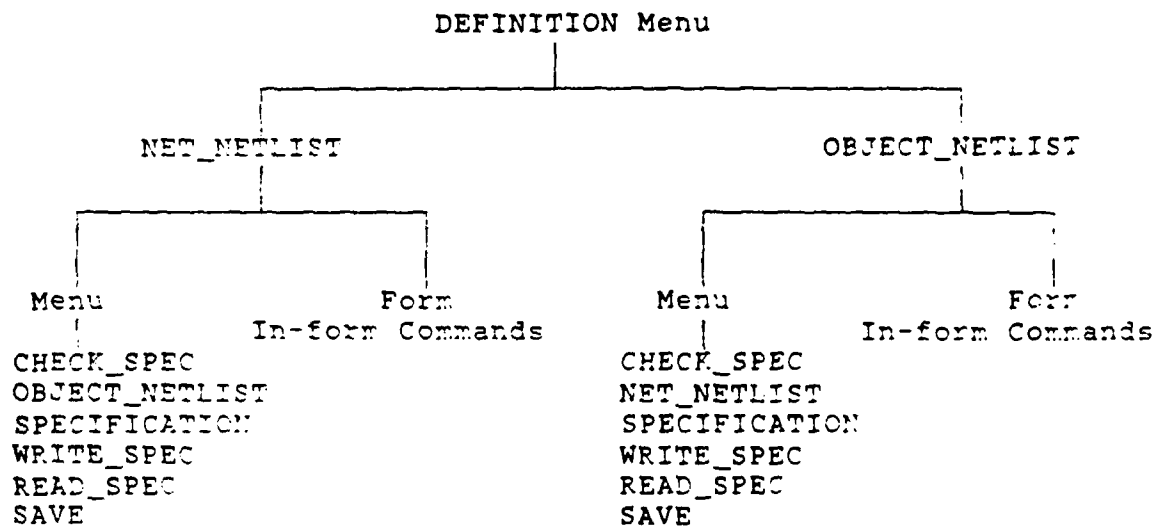

Figure 2.4 Netlisting Command Hierarchy

4. Floorplanning

Floorplanning consists of the actual placement of objects on a module or chip, the connection of pins to pads or pinout, and fusion order specification. Placement refers to the actual geographic locations of objects in relation to one another. The placement feature allows the user to graphically determine the placement between objects to minimize wire lengths. Genesil provides the appropriate menu depending on the object type. The pinout option provides for assignment of external signals to on chip (signals not local to an object) and off chip (I/O pins and pads) and is required for all modules and chips. Fusion allows the user to create and modify routing channel assignments on the floorplan by binding objects together to form channels [Ref. 6:p. 7.15]. Fusion may be accomplished automatically and then changed manually from the command selection form for more efficient routing. Figure 2.5 [Ref. 6:p. 7.25] depicts the Floorplanning Command Hierarchy.

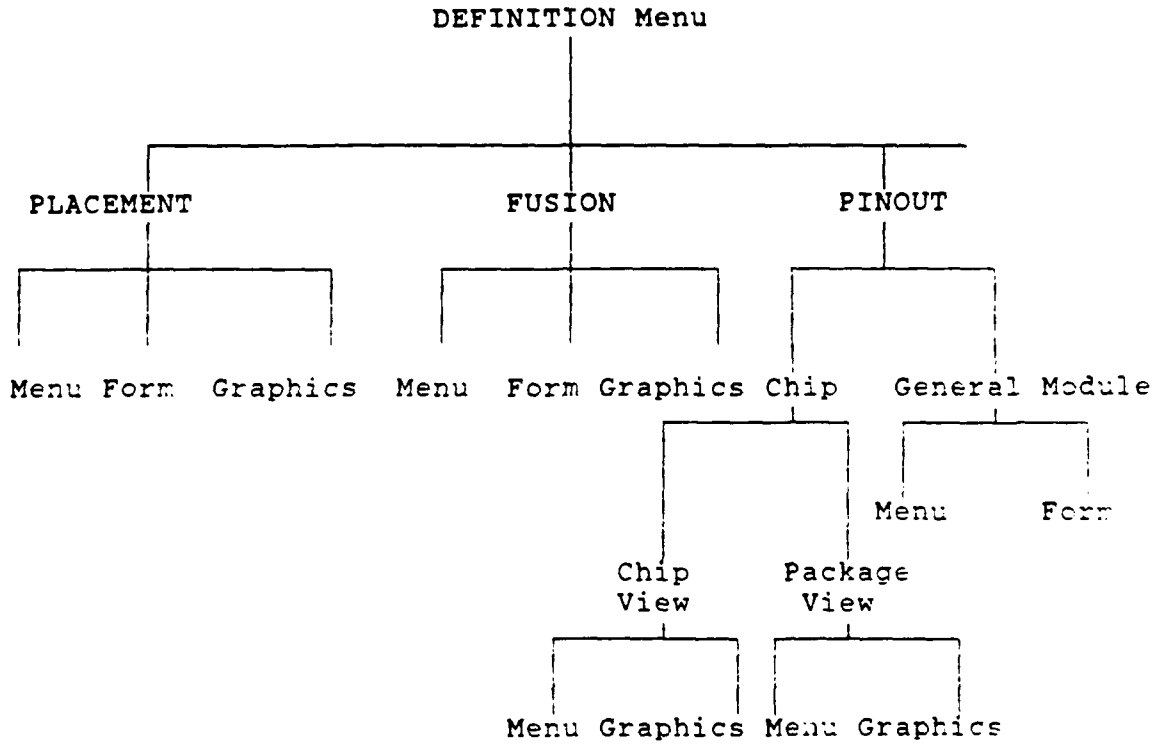

Figure 2.5 Floorplanning Command Hierarchy

5. Compiling

Compile is a command option that allows the user to force an immediate compilation of the complete set of views or selected views of the selected object. A view is one of three Genesil System representations of a block, which are geometric, functional, and timing. Compilation must be completed prior to simulation, timing analysis, plot, or tooling activities. It is automatically done if simulation or timing analysis is attempted prior to compile selection because the system checks the objects files for compilation currency. For efficiency, it was found that each block of objects should be compiled at the completion of design and netlisting. Figure 2.6 [Ref. 8:p. A.7] shows the compile menu of commands.

```
COMPILE Menu
|
SIM_MODEL
TA_MODEL
LOAD_MODEL
GATE_MODEL
LAYOUT
BUILD_ALL
CHECK
AUTO_DEF_SPEC
|
INTERACTIVE
ABORT_GO_ON
```

Figure 2.6 Compile Menu

During initial design phase, the most significant compile commands include Build_All, Sim_Model, and Ta_Model. The Build_All commands compile all views of the current object. Sim-Model compiles the simulation model needed for simulation of the current model. Ta-Model compiles the timing model necessary for timing analysis of the current object.

6. Simulation

The purpose of simulation is to verify that the design and layout generated by the current object are logically correct. The layout is synonymous with the geometric view of an object and is the physical equivalent of that object. The two most significant modes are functional and switch-level simulation.

Functional simulation generates a gate-level model for general purpose simulation and is independent of technology and layout. It is dependent only on circuit functionality and input signal changes. To perform functional simulation, the block must be defined and netlisted. Functional simulation is based on a demand-evaluation algorithm which creates a functional model that simulates only the minimum logic required for correct results [Ref. 9:p. 2.1]. The user designates net values and manually advances time across a clock edge.

Following design functionality verification, the object is floorplanned, resulting in the compilation of a layout. From the layout, switch-level simulation is used to

verify functionality of the actual layout of the chip. Switch-level simulation uses an event-driven algorithm which is 5-10 times slower than functional simulation and is best used during final verification only. The algorithm is much slower because it depends on detailed signal propagation data extracted from timing analysis [Ref. 9:p. 2.2].

7. Timing Analysis

Timing command selection places the user in the general Timing Analyser (TA). The system then uses an algorithm that requires no test vectors and generates the following timing specs [Ref. 10:p. 1.1]:

- Object propagation delays
- Paths limiting clock frequency
- Duty-cycle constraints
- Input setup and hold times
- Output delays
- Internal node setup, hold times, and signal delays
- Path delays between internal nodes.

The user then selects a menu command to generate a timing report for the desired information listed above. The TA can be used at any time during design following Definition Specification for random logic objects or blocks, and following Definition Specification and Floorplanning for modules or chips. Figure 2.7 [Ref. 10:p.1.1] shows the Timing Analysis environment.

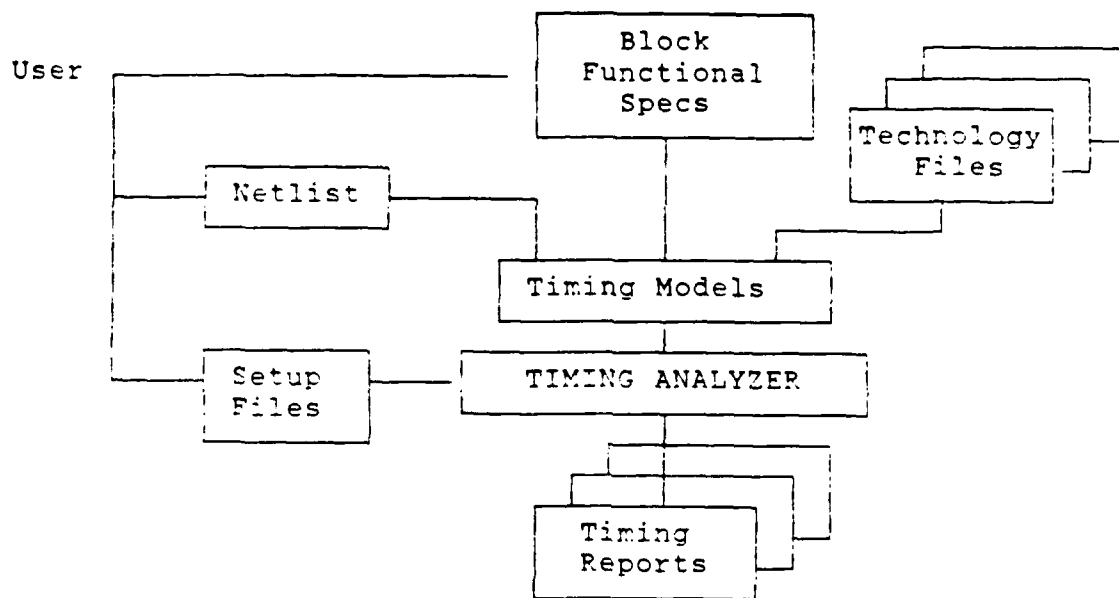

Figure 2.7 Timing Analysis Environment

8. Manufacture Interface

After a chip is completely specified and verified in terms of functionality, timing, power dissipation, and size, the design is ready to be sent to a foundry specified on the chip's definition header form. A foundry, or factory which produces the chip, may be changed at any time by changing the selection on the header form and re-compiling the chip. Design specifications are altered with each foundry change. The fabline, or process used to make the chip, changes with each foundry change which affects chip size, power, and timing results. Changes occur because chip layout differs due to the selected fabline's design rule check, and each foundry has its own models for devices built on that particular fabline [Ref. 6:p. 11.2].

III. ADDER CIRCUITS

A. PIPELINED CIRCUITS FOR HIGH PERFORMANCE

The purpose of pipelined circuits is to increase the through-put or performance of a circuit by splitting the task to be performed into cascaded sub-functions or smaller pieces and allocating separate hardware to each piece. Each piece or sub-function is defined as a stage. A stage normally consists of two components. They are the combinational logic to perform the sub-function, and a latch or flip-flop to save the output of one stage as input to the next. The concept is analagous with a physical pipeline or automobile assemblyline. Data flows through the stages of the circuit at a rate which is independent of the length of the pipeline or number of stages. If the overall function is completed in "X" nanoseconds(ns), and the function is divided into "N" stages, or sub-functions, then the output of the original function can theoretically be increased by "X/N" ns. This results in an "N" fold increase of performance [Ref. 11].

There are physical limitations on "N" due to hardware technology, the function being pipelined, clock-skew, and critical race. References 11 and 12 address hardware and function limitations. Clock-skew, due to circuit lengths, loading, and driver circuits, makes it nearly impossible to guarantee that all stages of a pipelined circuit receive the same pulse at exactly the same time. Critical race refers to

the situation where a datapath through a logic block in a stage may be so short that, if the latch changes its output early, the change may reach the next staging latch and change it during the same clock pulse [Ref. 1]. For this reason, usually flip-flops are used between logic stages or a two phase clock system is used with latches, each phase serving alternate stage latches. Two stages and a basic pipeline clock are shown in Figure 3.1 [Ref. 12:p. 36].

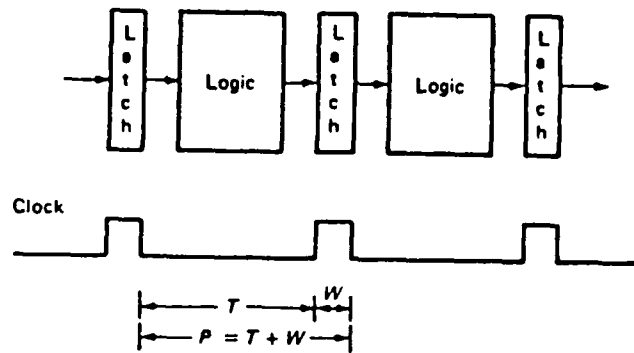

Figure 3.1 Two Stages and Pipeline Clock

B. FULL ADDER DESIGN

1. Introduction

Full adders serve a significant role in high performance pipelined signal processing circuits. High performance custom signal processing filters consist of pipelined adders and multipliers built from full adders. The Genesil Silicon Compiler system library contains full adders which can be programmed, via a menu, from 1 to 16 bits in

width. The performance and size of a 1 bit library full adder were compared with the performance and size of a custom full adder built on the Genesil System. Motivation for performance and size data stemmed from the research data presented in Chapter IV, where full adders were used to build high performance pipelined multiplier chips.

2. Genesil Silicon Compiler Library Full Adder

A full adder, shown in Figure 3.2 [Ref, 13;p. 2.1], was extracted from the Genesil Compiler Library, Volume III, which is a collection of all system random logic blocks available. The figure illustrated the only transparent information available to the user concerning a full adder.

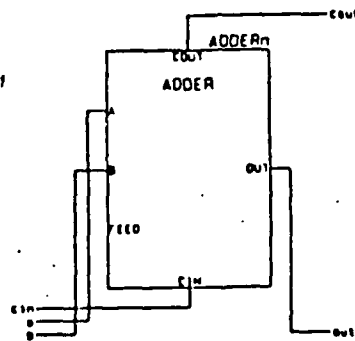

Figure 3.2 Genesil View of Adder Block

The figure depicts two data input buses (A and B), and a single carry input (Cin) which are added together resulting in the data output bus (OUT) and a carry output (COUT) [Ref. 3]. The manual offered no internal logic circuit diagrams nor performance and size specifications for the adder. Since the adder width can be varied from 1 to 16 bits, the interest was

in whether the system used a general algorithm for adder construction, possibly resulting in wasted size and unnecessary hardware, or if it "customized" the adder to user specifications.

A 1 bit full adder block called lib_fulladd_blk was constructed, and a VLSI layout is shown in Figure 3.3.

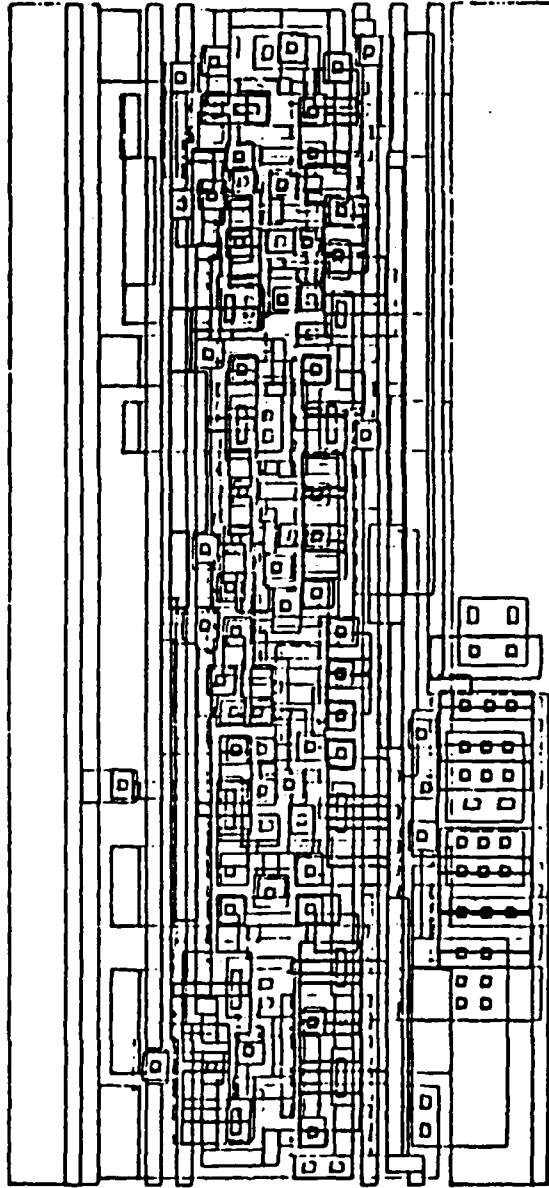

Figure 3.3 Genesil 1 Bit Full Adder Layout

The object size, calculated by the system, was 3.56 X 7.42 mils, resulting in a total area of 26.15 square mils.

Timing analysis was performed on the block which resulted in the Timing Analyser output propagation delays shown in Table I.

TABLE I
GENESIL FULL ADDER OUTPUT PROPAGATION DELAYS

OUTPUT	OUTPUT DELAYS (ns)	
	MIN	MAX
COUT	1.9	4.7
SUM	1.6	5.2

3. Custom Full Adder

A typical full adder was constructed from exclusive-or gates, AND gates, and OR gate as shown in Figure 3.4 [Ref. 14].

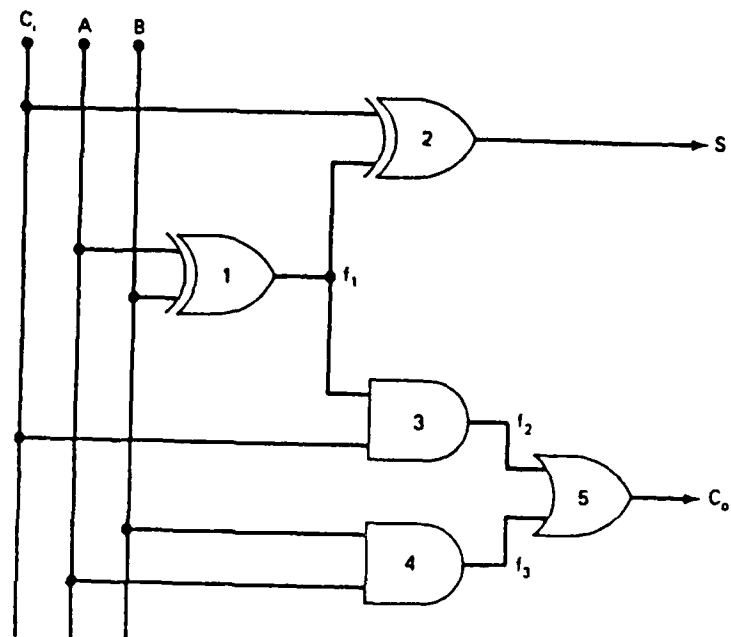

Figure 3.4 Full Adder Logic Circuit

An object called `cus_fulladd_blk` was constructed and a VLSI layout is shown in Figure 3.5.

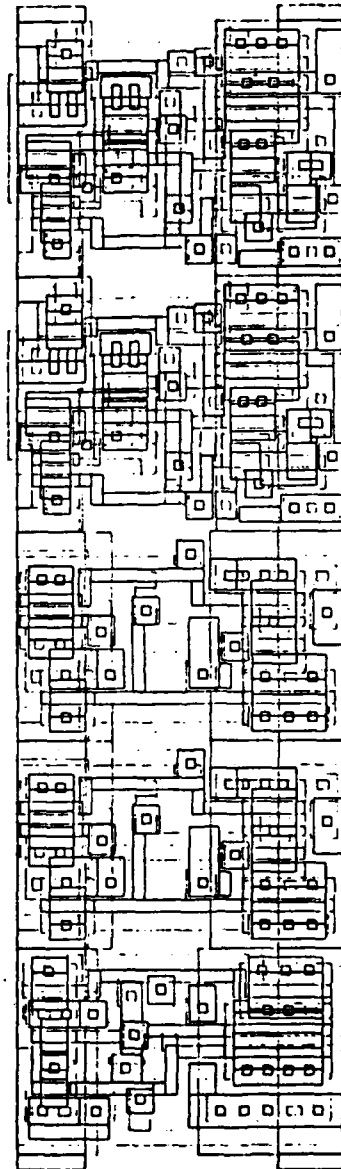

Figure 3.5 Custom 1 Bit Full Adder Layout

The object size, in mils, as calculated by the system was 7.58 X 2.42. This resulted in a total area of 18.34 square mils.

Timing analysis was performed by the system timing analyzer resulting in output propagation delays presented in Table II.

TABLE II
CUSTOM FULL ADDER OUTPUT PROPAGATION DELAYS

OUTPUT	OUTPUT DELAYS (ns)	
	MIN	MAX
COUT	2.5	5.0
SUM	1.4	4.6

4. Results

The results of a comparison between the system library full adder and the custom full adder are summarized in Table III.

TABLE III
SIZE AND PERFORMANCE SUMMARY

	MAX PROPAGATION DELAY (ns)	TOTAL AREA (SQ MILS)
GENESIL FULL ADDER	5.2	26.15
CUSTOM FULL ADDER	5.0	18.34

The data indicate that the custom full adder provides a 0.2ns performance improvement with 7.81 square mils saving in area.

C. FOUR BIT ADDER DESIGN

1. Introduction

The four bit adder is the building block for high performance pipelined adders. A basic four bit adder is a ripple carry circuit consisting of four full adders. The carry out of each adder ripples down as one of the three inputs to the next adder. Performance size considerations influence the appropriate design. Designs include pipelining full adders with latches, four bit carry-lock-ahead adders (CLA), and pipelined CLA. A pure performance pipelined CLA is described in Reference 15.

2. Genesil Silicon Compiler Library Four Bit Adder

A library four bit adder called lib_4bit_blk was constructed by using the Random Logic Block Specification menu shown in Figure 3.6.

```

Block type:  ADDEP
Block index: 0
Name:        >ADDERO__
Width:      >_4

```

Connector	Width	Regime			
		: Timing			
A	4	1 Prop(t)	[3]	>A3	_____
			[2]	>A2	_____
			[1]	>A1	_____
			[0]	>A0	_____
B	4	1 Prop(t)	[3]	>B3	_____
			[2]	>B2	_____
			[1]	>B1	_____
			[0]	>B0	_____
OUT	4	1 Prop(t)	[3]	>S3	_____
			[2]	>S2	_____
			[1]	>S1	_____
			[0]	>S0	_____
CIN	1	1 Prop(t)	[0]	>Ci	_____
COU	1	1 Prop(t)	[0]	>Co	_____
FEED	4	1 Feed thru	[3]	>FALSE	_____
			[2]	>FALSE	_____
			[1]	>FALSE	_____
			[0]	>FALSE	_____

Figure 3.6 Genesis 4 Bit Adder Specification Menu

Signal names were specified for the A and B buses, the 4 bit sum (OUT), carry-in (CIN), and carry-out (COU).

A VLSI layout of the adder was constructed by using the system's plot feature and is shown in Figure 3.7.

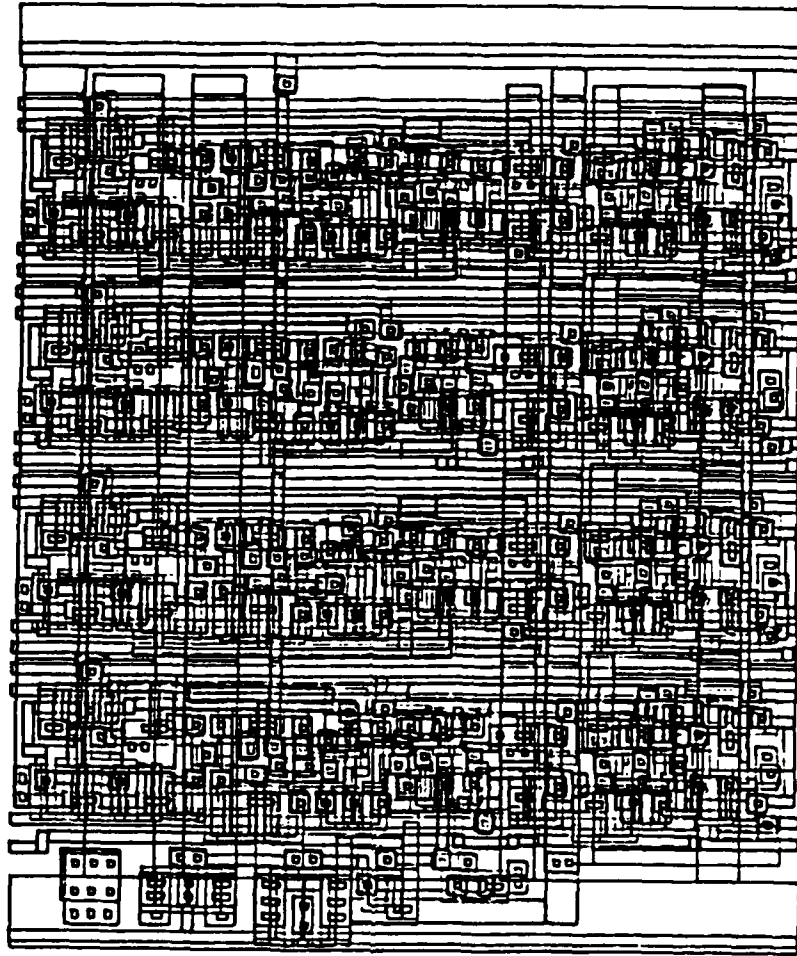

Figure 3.7 Genesil Layout lib_4bit_blk

The size of the adder, calculated by the system during layout, measured 8.77 X 7.42 mils, resulting in a total area of 65.07 square mils.

Timing analysis, provided by the System Timing Analyzer, produced the output propagation delays for all output signals. Data are provided in Table IV.

TABLE IV
GENESIL 4 BIT ADDER OUTPUT PROPAGATION DELAYS

OUTPUT	OUTPUT DELAYS (ns)	
	MIN	MAX
Co	1.9	9.5
S0	1.6	5.2
S1	3.1	6.3
S2	2.3	8.0
S3	3.1	9.2

Maximum propagation delay was 9.5 ns, occurring at the carry-out (Co) output.

3. Custom Four Bit Carry-Look-Ahead (CLA) Adder

The Genesil System manuals provide no information concerning any CLA features of the library adder. Without CLA, addition can become inefficient, but by pipelining conventional adder circuitry, performance can be increased at the price of additional hardware. CLA circuits involve more hardware than ripple carry circuits, but are faster.

The principle of CLA circuits involves anticipating when and where a carry will be generated. The circuit "looks ahead" to see where the carry is needed. References 15 and 16 provide detailed CLA algorithm development and analysis. The circuit shown in Figure 3.8 [Ref. 17] was constructed for a performance and size comparison with the Genesil 4 bit adder.

Figure 3.9 shows the Random Logic Functional Specification menu used to build the CLA circuit. Each random logic object was specified, signals designated, and the circuit net-listed.

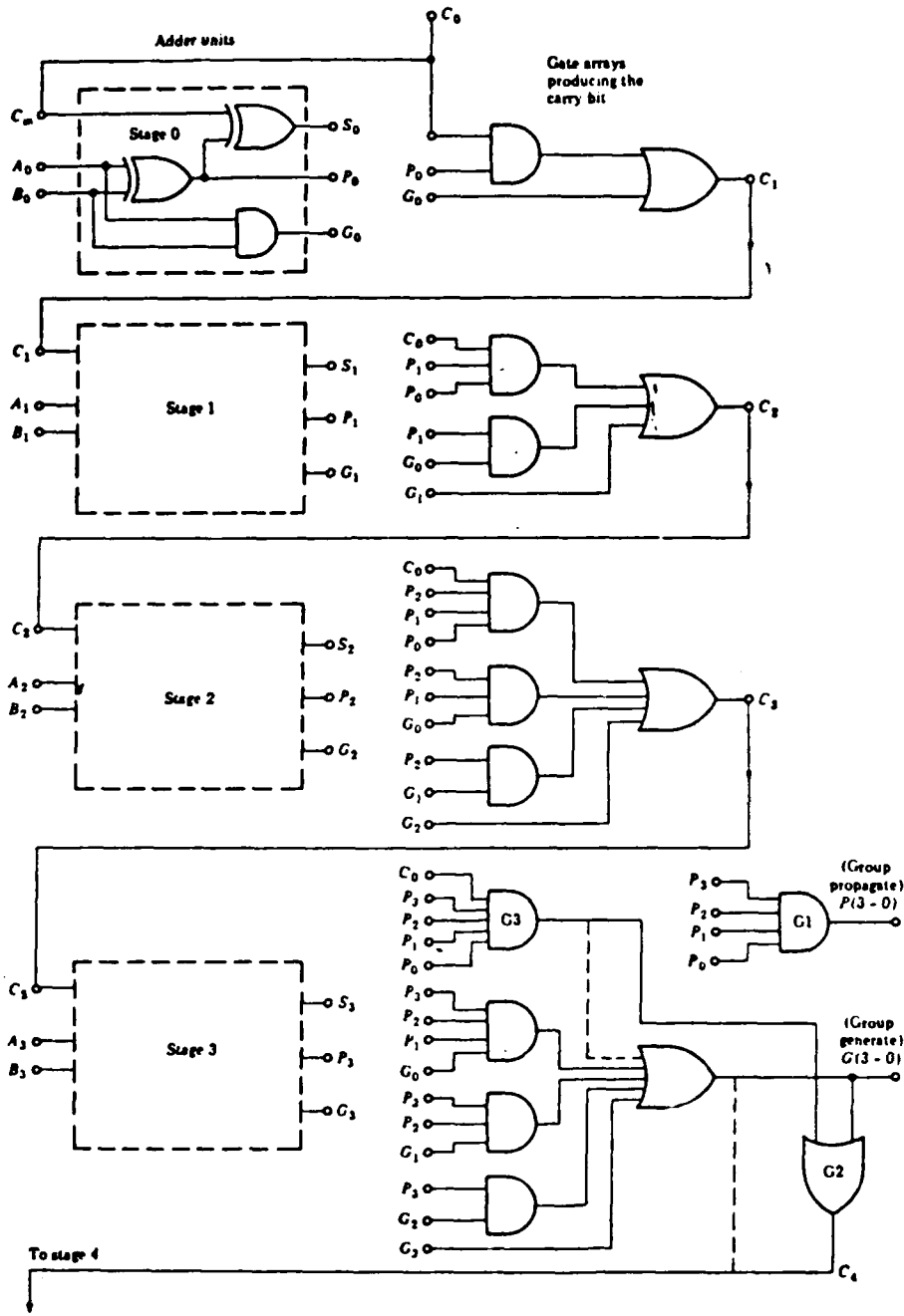

Figure 3.8 4 Bit CLA Adder

DEL	EDIT	MOVE	0:	>XOR0	_____	(XOR)
DEL	EDIT	MOVE	1:	>XOR1	_____	(XOR)
DEL	EDIT	MOVE	2:	>AND2	_____	(AND)
DEL	EDIT	MOVE	3:	>AND3	_____	(AND)
DEL	EDIT	MOVE	4:	>OR4	_____	(OR)
DEL	EDIT	MOVE	5:	>XOR5	_____	(XOR)
DEL	EDIT	MOVE	6:	>XOR6	_____	(XOR)
DEL	EDIT	MOVE	7:	>AND7	_____	(AND)
DEL	EDIT	MOVE	8:	>AND8	_____	(AND)
DEL	EDIT	MOVE	9:	>AND9	_____	(AND)
DEL	EDIT	MOVE	10:	>AND10	_____	(AND)
DEL	EDIT	MOVE	11:	>OR11	_____	(OR)
DEL	EDIT	MOVE	12:	>XOR12	_____	(XOR)
DEL	EDIT	MOVE	13:	>AND13	_____	(AND)
DEL	EDIT	MOVE	14:	>AND14	_____	(AND)
DEL	EDIT	MOVE	15:	>AND15	_____	(AND)
DEL	EDIT	MOVE	16:	>AND16	_____	(AND)
DEL	EDIT	MOVE	17:	>OR17	_____	(OR)
DEL	EDIT	MOVE	18:	>XOR18	_____	(XOR)
DEL	EDIT	MOVE	19:	>XOR19	_____	(XOR)
DEL	EDIT	MOVE	20:	>AND20	_____	(AND)
DEL	EDIT	MOVE	21:	>AND21	_____	(AND)
DEL	EDIT	MOVE	22:	>AND22	_____	(AND)
DEL	EDIT	MOVE	23:	>AND23	_____	(AND)
DEL	EDIT	MOVE	24:	>AND24	_____	(AND)
DEL	EDIT	MOVE	25:	>OR25	_____	(OR)

Figure 3.9 Random Logic Functional Specification Menu

An object layout of the CLA block called `cus_cla4bit_blk` was completed. The system calculated the size of the object as 44.53 X 2.42 mils, resulting in a total area of 107.76 square mils.

Since this was a custom object, the System Functional Simulator was used to test for correct logic. Random values were put on the inputs, the system clocks cycled, and results read from the Functional Simulator menu. An example simulation run extracted from the Functional Simulator is included as Figure 3.10.

```
> /cus_cla4bit_blk is of type genblock/rl with 28 ports
> port 0 I A0 to NC = 1
> port 1 I A1 to NC = 1
> port 2 I B0 to NC = 1
> port 3 I A2 to NC = 1
> port 4 I B1 to NC = 1
> port 5 I A3 to NC = 1
> port 6 I B2 to NC = 1
> port 7 I B3 to NC = 1
> port 8 O C4 to NC = 1
> port 9 O S0 to NC = 1
> port 10 O S1 to NC = 1
> port 11 O S2 to NC = 1
> port 12 O S3 to NC = 1
> port 13 I Ci to NC = 1
```

Figure 3.10 4 Bit CLA Simulation

The System Timing Analyser was used for output propagation delays data for all output signals. The results are shown in Table V.

TABLE V
4 BIT CLA OUTPUT PROPAGATION DELAYS

OUTPUT	OUTPUT DELAYS (ns)	
	MIN	MAX
C4	2.8	6.9
S0	1.4	5.1
S1	3.8	7.6
S2	3.8	8.7
S3	3.5	9.0

Maximum propagation delay was 9.0 ns, occurring at the most significant bit output (S3).

4. Results

The results of the comparison are summarized in Table VI.

TABLE VI
SIZE AND PERFORMANCE SUMMARY

	MAX PROPAGATION DELAY (ns)	TOTAL AREA (Sq Mils)
GENESIL 4 BIT ADDER	9.5	65.07
CUSTOM 4 BIT CLA ADDER	9.0	107.76

The data indicate that the custom CLA provides a 0.5 ns performance improvement, but is 42.69 square mils larger than the library adder. The performance of the library adder

indicates that the circuit probably has CLA circuitry included in the system adder algorithm.

D. SIXTEEN BIT ADDER DESIGN

1. Introduction

The pipelined 16 bit adder can be used in conjunction with two's complement hardware for special purpose signal processors, in the final stages of a 16 bit multiplier as presented in Chapter IV, or in various other capacities involved with high performance special purpose hardware. This section compares the performance and size of a 16 bit Genesil library adder with a custom 16 bit adder built on the Genesil System. Additional pipelined adder designs and performance data are available in Reference 18.

2. Genesil Library 16 Bit Adder

A library 16 bit adder called lib_16bit_blk was constructed by using the Random Logic Block Specification menu shown in Figure 3.11.

```
Block type:  ADDER
Block index: 0
Name:        >ADDERO__
Width:       >16

                Regime
Connector Width  Timing
A                16    1 Prop(t)  >A[15:0]_____
B                16    1 Prop(t)  >B[15:0]_____
OUT              16    1 Prop(t)  >S[15:0]_____
CIN              1     1 Prop(t)  >Ci_____
COUT             1     1 Prop(t)  >Co_____
FEED             16    1 Feedthru >FALSE*16
```

Figure 3.11 Genesil 16 Bit Adder Specification Menu

Input signal names, in bus notation, were specified for the A (A[15:0]) and B (B[15:0]) buses, and Cin. Output signals included sum (s[15:0]), in bus notation, and Co.

A VLSI layout from the system plot feature is included as Figure 3.12.

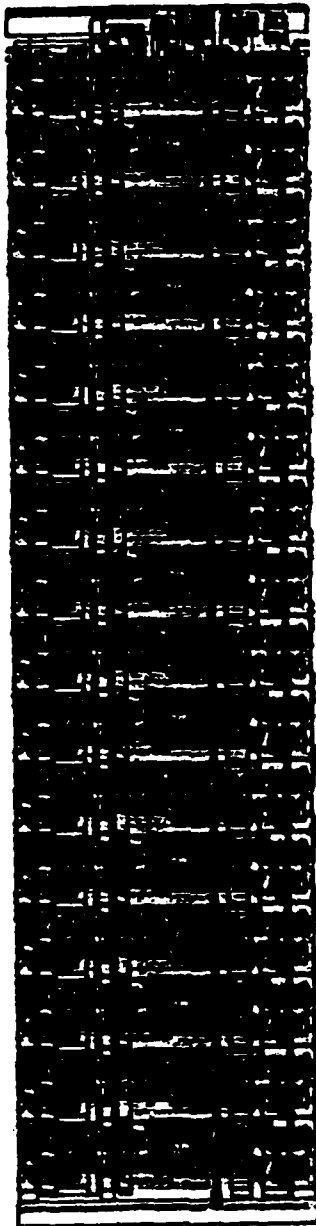

Figure 3.12 Genesil Layout lib_16bit_blk

The size of the library 16 bit full adder was calculated by the system to be 29.56 X 7.42 mils, resulting in a total area of 219.33 square mils.

Output propagation delays for all signals were calculated by the System Timing Analyser and are presented in Table VII.

TABLE VII
GENESIL 16 BIT ADDER OUTPUT PROPAGATION DELAYS

OUTPUT	OUTPUT DELAYS (ns)	
	MIN	MAX
Co	1.9	27.2
S[0]	1.6	5.2
S[10]	2.3	19.8
S[11]	3.1	21.1
S[12]	2.3	22.8
S[13]	3.1	24.0
S[14]	2.3	25.7
S[15]	3.1	27.0
S[1]	3.1	6.3
S[2]	2.3	8.0
S[3]	3.1	9.2
S[4]	2.3	11.0
S[5]	3.1	12.1
S[6]	2.3	13.9
S[7]	3.1	15.2
S[8]	2.3	16.9
S[9]	3.1	18.1

Maximum propagation delay was 27.2 ns, occurring at the carry-out (Co) signal.

3. Custom 16 Bit Pipelined Adder

A custom 16 bit adder was constructed using Genesil library 4 bit adders for the add logic, and 2-phase library D flip/flops to retain the data between each stage. The library adders were used because the performance and size comparison with a 4 bit CLA previously completed indicated that the differences were insignificant for the purposes of this section. An attempt to build a custom Earle latch, as presented in Reference 12, failed because the system disallowed random logic gate output signals to simultaneously perform as both external output signals and internal feedback signals. This feature is required for memory in both the D flip/flop and Earle latch. This problem was not pursued further because a library D flip/flop setup and hold time was found not to exceed 6.5 ns. This was approximately 3.0 ns less than the 4 bit library adder which was used in each stage of the adder. The adder logic, therefore, was the dominating delay factor driving the clock speed. Figure 3.13 shows the design, in block diagram form, used to construct the adder on Genesil.

Figure 3.14 shows a VLSI layout of the custom 16 bit pipelined adder module, without input/output pads, constructed for performance and size comparison with the library adder. The module was floorplanned using the list-best command in the floorplan menu. This feature graphically advised the user of the best placement of the 5 stages in the module for optimum

routing and fusion. The adder module was 21.89 X 339.19 mils,
resulting in a total area of 7424.87 square mils.

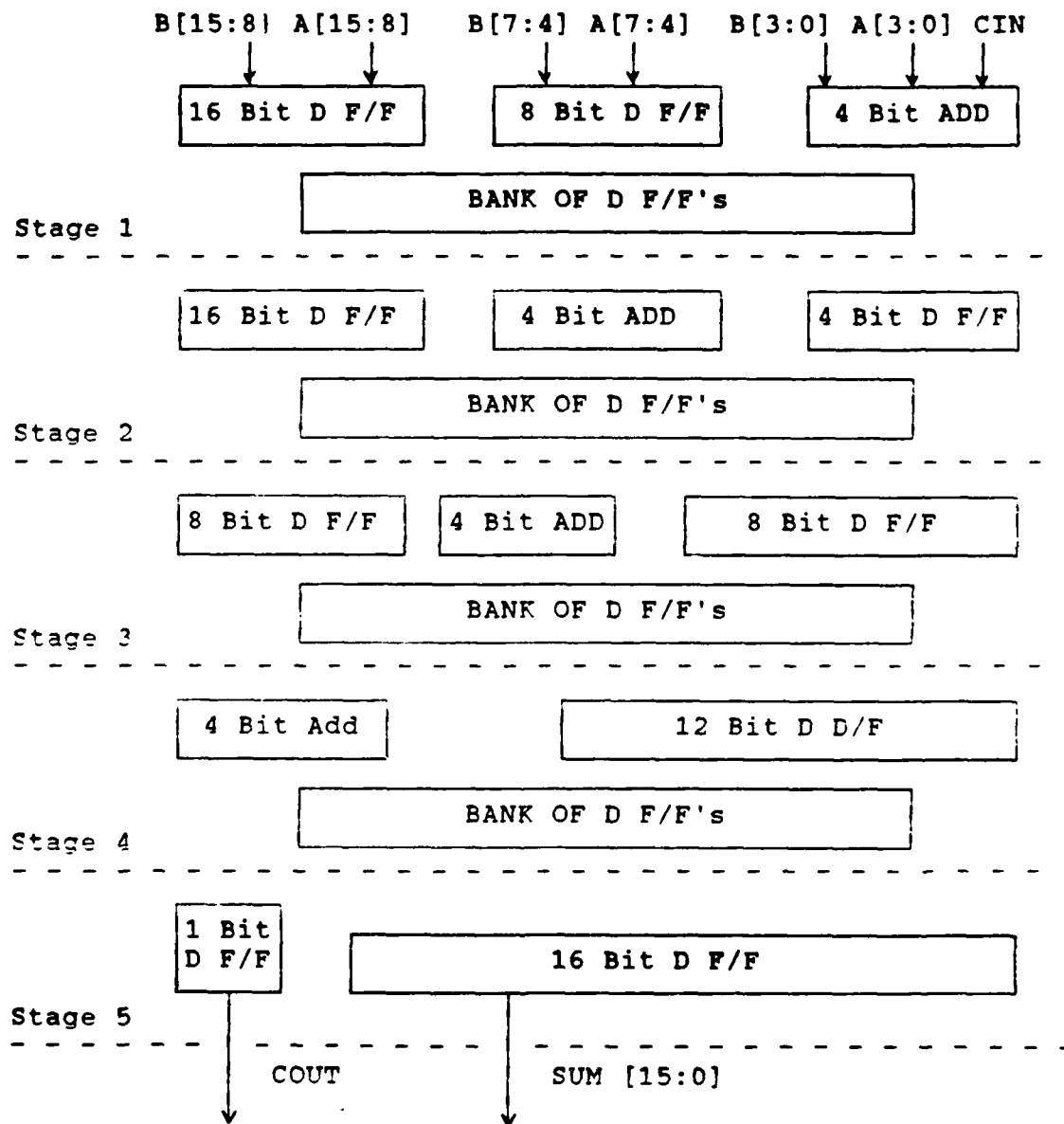

Figure 3.13 16 Bit Pipelined Adder Design



Figure 3.14 List-Best Floorplanned
16 Bit Pipelined Adder

As a size and routing comparison, Figure 3.15 shows the same adder modules stages placed manually. The size of this module was 55.41 X 91.42 mils, resulting in a total area of 5066.50 square mils.

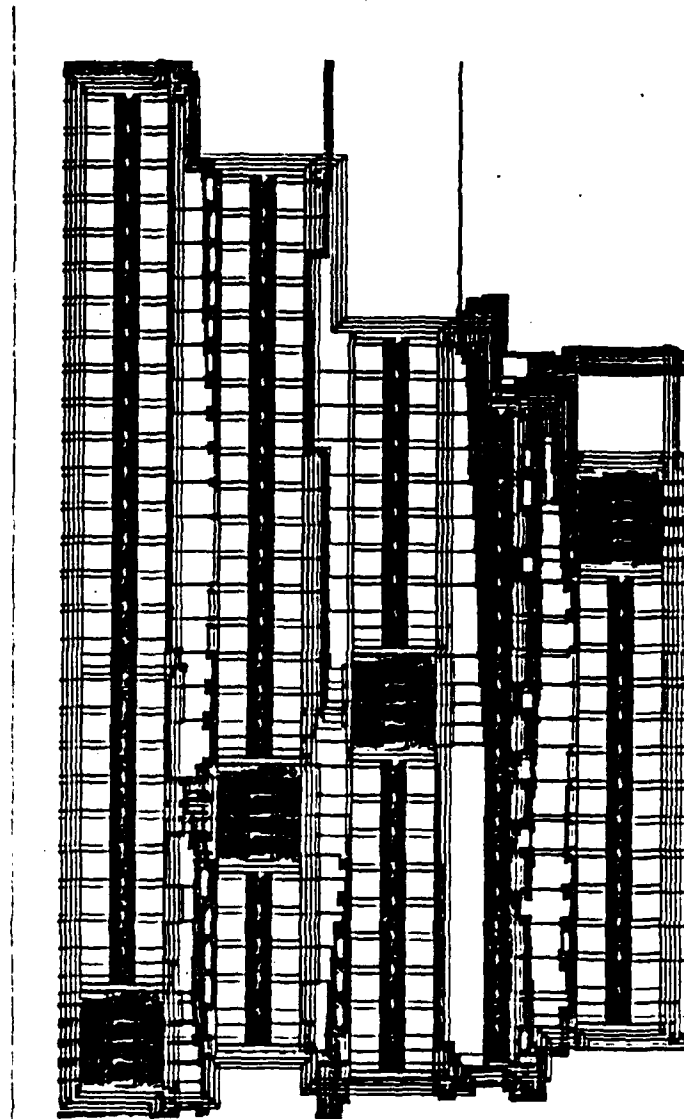

Figure 3.15 Manually Floorplanned
16 Bit Pipelined Adder

Although this design was significantly smaller than the one floorplanned by the system, routing and fusion of the module floorplanned by the system took a significantly shorter time to complete. The system floorplanned module took 10 to 15 minutes to route, while the manually floorplanned module took 1 to 2 hours to complete the routing.

Figure 3.16 shows the pipelined adder with the pads attached. This figure was included to demonstrate the significant increase in chip size experienced with the addition of pads and associated routing. The size of the chip increased to 171.83 X 385.83 mils, resulting in a total area of 66,297.17 square mils.

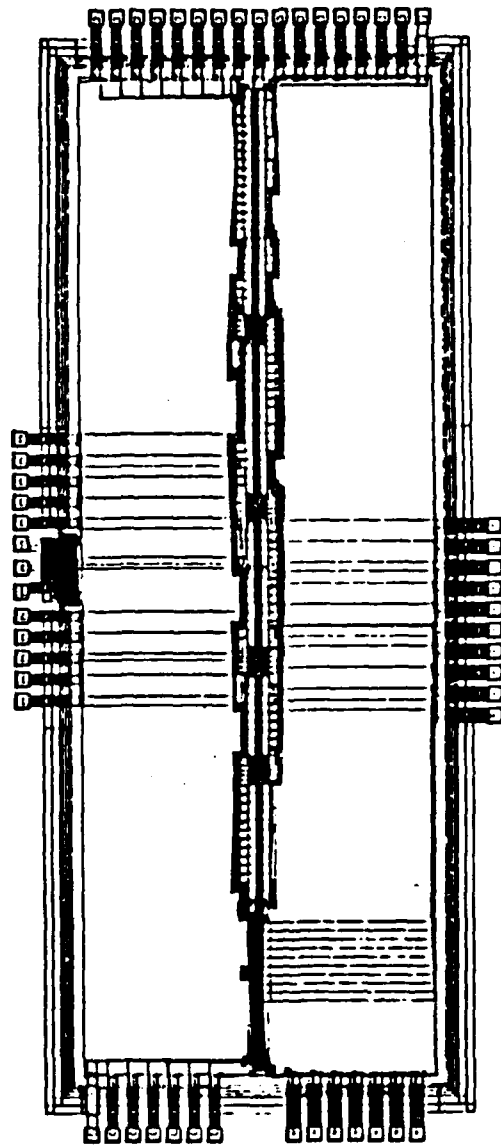

Figure 3.16 16 Bit Pipelined Adder With Pads

Simulation was performed for logic validation using the Functional Simulator. Various combinations of binary integers were placed on the input signal buses, the system clocks cycled, and test results were observed on the output signal buses. Figure 3.17 shows a sample of a simulation test run extracted from the Functional Simulation output form.

```
> is of type module with 48 ports
> port 1 I TRUE to NC = H
> port 3 I FALSE to NC = L
> port 5 O a1[15:0] to NC*16 = 1111111111111110
> port 7 I a[15:0] to NC*16 = HHHHHHHHHHHHHHHH
> port 9 O b1[15:4] to NC*12 = 111111111111
> port 11 I b[15:0] to NC*16 = HHHHHHHHHHHHHHHH
> port 13 O c1o to NC = 1
> port 15 CI phase_a to NC = 1
> port 17 CI phase_b to NC = 0
> port 20 O a2[15:8] to NC*8 = 11111111
> port 21 O a2[3:0] to NC*4 = 1111
> port 23 O b2[18:8] to NC*8 = 11111111
> port 25 O c2o to NC = 1
> port 27 O d0[3:0] to NC*4 = 1110
> port 30 O a3[15:12] to NC*4 = 1111
> port 31 O a3[3:0] to NC*4 = 1111
> port 33 O b3[15:12] to NC*4 = 1111
> port 35 O c3o to NC = 1
> port 37 O d3[7:0] to NC*8 = 11111110
> port 39 O a4[3:0] to NC*4 = 1111
> port 41 O c4 to NC = 1
> port 43 O d4[11:0] to NC*12 = 111111111110
> port 45 O carry to NC = 1
> port 47 O sum[15:0] to NC*16 = 1111111111111110
```

Figure 3.17 Simulation Results of 16 Bit Pipelined Adder

Timing analysis was performed to investigate the worst case delay in each stage of the adder. Figure 3.18 through Figure 3.22 list the worst case propagation delays and identifies the worst case signal for each of the five stages

of the pipelined adder. The data indicate that the largest propagation delay was 9.5 ns which occurred in stages 1 through 4. This delay is attributed to the library 4 bit adder used in each of these stages.

Output	OUTPUT DELAYS (ns)			
	Ph1(r)	Delay	Ph2(r)	Delay
	Min	Max	Min	Max
a1[0]	3.5	4.4	3.5	4.4
a1[10]	4.3	4.5	----	----
a1[11]	4.3	4.5	----	----
a1[12]	4.3	4.5	----	----
a1[13]	4.3	4.5	----	----
a1[14]	4.3	4.5	----	----
a1[15]	4.3	4.5	----	----
a1[1]	3.1	6.3	3.1	6.3
a1[2]	2.3	8.0	2.3	8.0
a1[3]	3.1	9.2	3.1	9.2
a1[4]	3.8	4.0	----	----
a1[5]	3.8	4.0	----	----
a1[6]	3.8	4.0	----	----
a1[7]	3.8	4.0	----	----
a1[8]	4.3	4.5	----	----
a1[9]	4.3	4.5	----	----
b1[10]	4.3	4.5	----	----
b1[11]	4.3	4.5	----	----
b1[12]	4.3	4.5	----	----
b1[13]	4.3	4.5	----	----
b1[14]	4.3	4.5	----	----
b1[15]	4.3	4.5	----	----
b1[4]	3.8	4.0	----	----
b1[5]	3.8	4.0	----	----
b1[5]	3.0	4.0	----	----
b1[6]	3.8	4.0	----	----
b1[7]	3.8	4.0	----	----
b1[8]	4.3	4.5	----	----
b1[9]	4.3	4.5	----	----
c1o	1.9	9.5	1.9	9.5

Figure 3.18 Stage_1 Output Delays

Output	OUTPUT DELAYS (ns)			
	Ph1(r)	Delay	Ph2(r)	Delay
	Min	Max	Min	Max
a2[0]	1.6	5.2	1.6	5.2
a2[10]	4.3	4.5	---	---
a2[11]	4.3	4.5	---	---
a2[11]	4.3	4.5	---	---
a2[12]	4.3	4.5	---	---
a2[13]	4.3	4.5	---	---
a2[14]	4.3	4.5	---	---
a2[15]	4.3	4.5	---	---
a2[1]	3.1	6.3	3.1	6.3
a2[2]	2.3	8.0	2.3	8.0
a2[3]	3.1	9.2	3.1	9.2
a2[8]	4.3	4.5	---	---
a2[9]	4.3	4.5	---	---
b2[10]	4.3	4.5	---	---
b2[11]	4.3	4.5	---	---
b2[12]	4.3	4.5	---	---
b2[13]	4.3	4.5	---	---
b2[14]	4.3	4.5	---	---
b2[15]	4.3	4.5	---	---
b2[8]	4.3	4.5	---	---
b2[9]	4.3	4.5	---	---
c2o	1.9	9.5	1.9	9.5
d0[0]	3.5	3.7	---	---
d0[1]	3.5	3.7	---	---
d0[2]	3.5	3.7	---	---
d0[3]	3.5	3.7	---	---

Figure 3.19 Stage_2 Output Delays

Output	OUTPUT DELAYS (ns)			
	Ph1(r)	Delay	Ph2(r)	Delay
	Min	Max	Min	Max
a3[0]	1.6	5.2	1.6	5.2
a3[12]	3.8	4.0	---	---
a3[13]	3.8	4.0	---	---
a3[14]	3.8	4.0	---	---
a3[15]	3.8	4.0	---	---
a3[1]	3.1	6.3	3.1	6.3
a3[2]	2.3	8.0	2.3	8.0
a3[3]	3.1	9.2	3.1	9.2
b3[12]	3.8	4.0	---	---
b3[13]	3.8	4.0	---	---
b3[14]	3.8	4.0	---	---
b3[15]	3.8	4.0	---	---
c3o	1.9	9.5	1.9	9.5
d3[0]	3.8	4.0	---	---
d3[1]	3.8	4.0	---	---
d3[2]	3.8	4.0	---	---
d3[3]	3.8	4.0	---	---
d3[4]	3.8	4.0	---	---
d3[5]	3.8	4.0	---	---
d3[6]	3.8	4.0	---	---
d3[7]	3.8	4.0	---	---

Figure 3.20 Stage_3 Output Delays

Output	OUTPUT DELAYS (ns)			
	Ph1(r)	Delay	Ph2(r)	Delay
	Min	Max	Min	Max
a4[0]	1.6	5.2	1.6	5.2
a4[1]	3.1	6.3	3.1	6.3
a4[2]	2.3	8.0	2.3	8.0
a4[3]	3.1	9.2	3.1	9.2
c4	1.9	9.5	1.9	9.5
d4[0]	4.0	4.2	---	---
d4[10]	4.0	4.2	---	---
d4[11]	4.0	4.2	---	---
d4[1]	4.0	4.2	---	---
d4[1]	4.0	4.2	---	---
d4[2]	4.0	4.2	---	---
d4[3]	4.0	4.2	---	---
d4[4]	4.0	4.2	---	---
d4[5]	4.0	4.2	---	---
d4[6]	4.0	4.2	---	---
d4[7]	4.0	4.2	---	---
d4[8]	4.0	4.2	---	---
d4[9]	4.0	4.2	---	---

Figure 3.21 Stage_4 Output Delays

Output	OUTPUT DELAYS (ns)			
	Ph1(r)	Delay	Ph2(r)	Delay
	Min	Max	Min	Max
carry	3.3	3.5	---	---
sum[0]	4.3	4.5	---	---
sum[10]	4.3	4.5	---	---
sum[11]	4.3	4.5	---	---
sum[12]	4.3	4.5	---	---
sum[13]	4.3	4.5	---	---
sum[14]	4.3	4.5	---	---
sum[15]	4.3	4.5	---	---
sum[1]	4.3	4.5	---	---
sum[2]	4.3	4.5	---	---
sum[3]	4.3	4.5	---	---
sum[4]	4.3	4.5	---	---
sum[5]	4.3	4.5	---	---
sum[6]	4.3	4.5	---	---
sum[7]	4.3	4.5	---	---
sum[8]	4.3	4.5	---	---
sum[9]	4.3	4.5	---	---

Figure 3.22 Stage_5 Output Delays

4. Results

The results of the comparison between a standard 16 bit library adder and custom pipelined 16 bit adder are shown in Table VIII. These figures do not include delay associated with interstage flip-flops.

TABLE VIII
SIZE AND PERFORMANCE SUMMARY

	TOTAL AREA (Sq mils)	MAXIMUM PROPAGATION Delay (ns)
GENESIL 16 BIT ADDER	219.33	27.2
CUSTOM 16 BIT PIPELINED ADDER	7424.87	9.5

E. PERFORMANCE SUMMARY

Table IX is a summary of the size and performance results of the adders designed and constructed in this chapter.

TABLE IX
ADDERS SIZE AND PERFORMANCE SUMMARY

	TOTAL AREA (Sq mils)	MAXIMUM PROPAGATION Delay (ns)
GENESIL FULL ADDER	26.15	5.2
CUSTOM FULL ADDER	18.34	5.0
GENESIL 4 BIT ADDER	65.07	9.4
CUSTOM 4 BIT CLA ADDER	107.76	9.0
GENESIL 16 BIT ADDER	219.33	27.2
CUSTOM 16 BIT PIPELINED ADDER	7424.87	9.5

The data indicate that there is no significant performance advantage gained with the custom full and 4 bit adders. The custom 16 bit pipelined adder data clearly illustrate the performance advantage gained by pipelining.

IV. MULTIPLIER CIRCUITS

A. INTRODUCTION.

The binary multiplier is a major component of signal processor filters. Conventional ALU add and shift multiply functions and parallel multiplier circuits are not adequate for the speed requirements of the high speed processor. This chapter presents performance data on 4, 8, and 16 bit unsigned library multipliers, which are compared to a custom 4 and 16 bit pipelined multiplier.

The multiplication add-and-shift algorithm for two n-bit binary numbers are represented by Equation 4.1 [Refs. 11 and 16].

$$P = \sum_{k=0}^{n-1} 2^k a_k b_k \quad (4.1)$$

b represents the n-bit multiplication vector, a represents bits n of the multiplier vector a and p represents the 2n bit product vector. [Ref. 16:p. 11]

This concept is illustrated in Figure 4.1 [Ref. 16:p. 11] for the product of two 8-bit integers. The multiplication of the two 8-bit integers results in eight partial products, generated from the ANDING of the multiplicand (MC) and multiplier (MP) bits, which are then added to form the final product.

B. 4, 8, AND 16 BIT GENESIL LIBRARY MULTIPLIER

1. Multiplier Block Array Core

The Genesil library multiplier block array core is an array of half and full adders which provides a parallel multiplier scheme for integer and fraction/mantissa portions of floating-point numbers. In depth parallel multiplier theory and schematics are contained in Reference 4:pp. 344-348. The multiplier block array core and operation illustrating the product of 111001 multiplied by 1101 is shown in Figure 4.2 [Ref. 13:p. 4.3]. The block is designed for unsigned integer multiplication and requires external circuitry for signed operations. The least significant (LS) bits are produced directly from the array, but an external adder is required to complete the partial product addition of the most significant (MS) bits. The multiplier and multiplicand widths can be varied from 4 to 32 bits, but the multiplier width cannot exceed the multiplicand width.

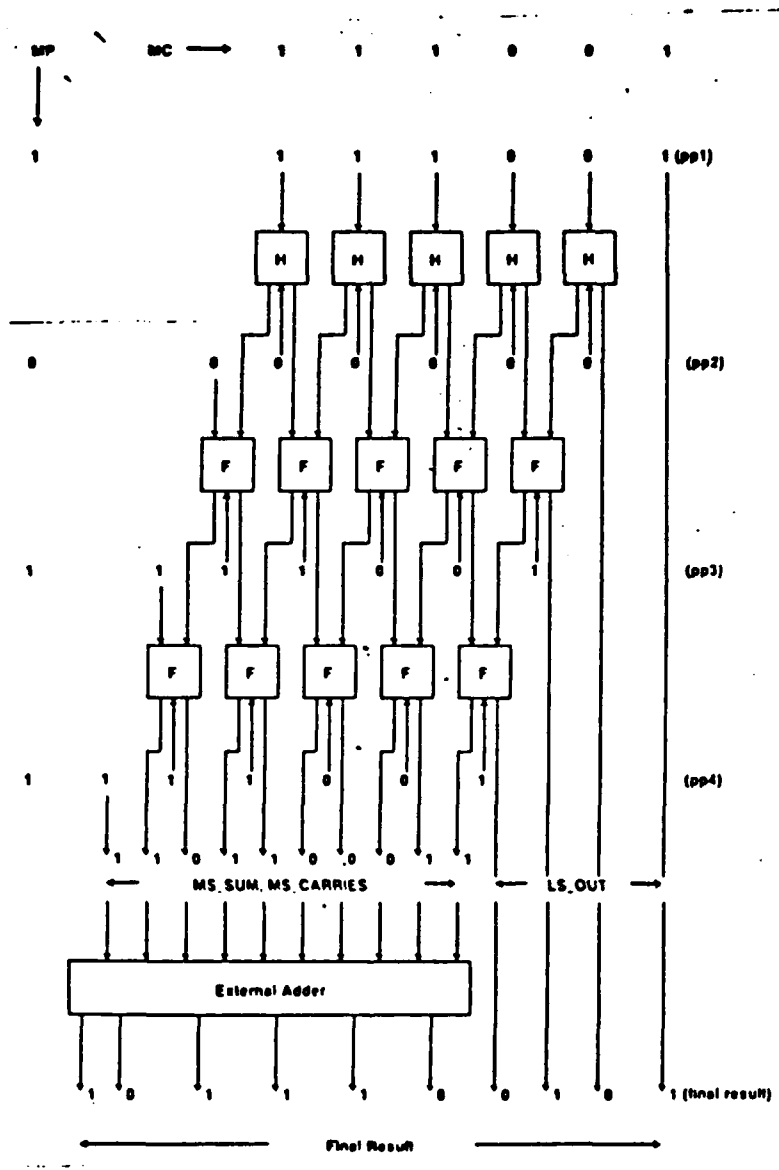

Figure 4.2 Multiplier Block Array Core and External Adder

2. 4, 8, and 16 Bit Multiplier Data

Three modules, containing 4, 8, and 16 bit Genesis1 library multipliers and external adders, were constructed from the Specification Menu. Each was simulated for correct logic and processed by the Timing Analyser for propagation delay data. The results are summarized in Table X.

TABLE X
4, 8, AND 16 BIT OUTPUT PROPAGATION DELAYS

	OUTPUT PROPAGATION DELAYS (ns)	
	MIN	MAX
4 BIT		
MS_SUM	3.2	10.9
LS_OUT	3.1	10.3
MS_OUT	5.3	18.8
8 BIT		
MS_SUM	4.1	24.4
LS_OUT	3.2	23.4
MS_OUT	5.9	38.2
16 BIT		
MS_SUM	4.6	51.0
LS_OUT	3.2	49.4
MS_OUT	6.9	77.0

The MS_SUM data are the propagation delays of the array core only. MS_OUT is the total propagation delay of both the core and external adder.

The addition of D flip/flops between the core and external adder in Figure 4.2 decreased the propagation delay driving the maximum clock speed allowable for the circuit to

that of the MS_SUM output propagation delay. The D F/F inputs were MS_SUM, MS_CARRIES, and LS_OUT. MS_SUM and MS_CARRIES were then clocked into the external adder or next stage of the pipeline. Table XI illustrates the theoretical allowable clock speed of a circuit using the multiplier modules considering each module with and without the D flip/flop insertion. The modules without D flip/flops inserted between the core and external adder, clock speeds were calculated assuming there was a D flip/flop attached to the outputs of the external adder and LS_OUT.

TABLE XI
THEORETICAL CLOCK SPEED OF
4, 8, AND 16 BIT LIBRARY MULTIPLIER

	CLOCK SPEED (MHZ)	
	WITHOUT D F/F INSERTED	WITH D F/F INSERTED
4 BIT MULTIPLIER	39.5	57.4
8 BIT MULTIPLIER	22.3	32.3
16 BIT MULTIPLIER	11.3	17.3

The data indicate that there was a significant increase of the allowable clock speed of a circuit using the multiplier modules with the addition of the D flip/flop inserted between the core and external adder.

C. 4 BIT PIPELINED MULTIPLIER

1. Introduction

This section presents performance data for a 4 bit pipelined multiplier using the Wallace Tree structure. Figure 4.3 illustrates a 4X4 multiplication in dot form [Ref. 16].

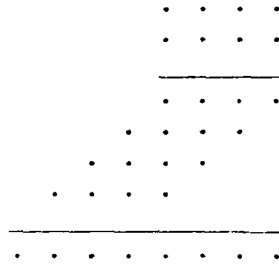

Figure 4.3 4X4 Multiply

After the partial products are formed, the three right columns of partial products are shifted down to form a pyramid or tree, as illustrated in Figure 4.5 [Ref. 16].

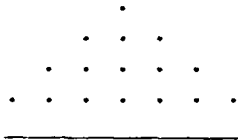

Figure 4.4 Wallace Tree Partial Products

Next, 3-input, 2-output full adders are used to compute carry save addition (CSA) for column reduction.

To reduce these columns of height h , CSA is used to reduce three dots of column height to two. These two output dots, which represent the familiar sum and carry outputs of a full adder, are placed in the next level of the tree structure in their appropriate positions. [Ref. 16:p.16]

This concept is illustrated in Figure 4.5 for a 4X4 multiplication.

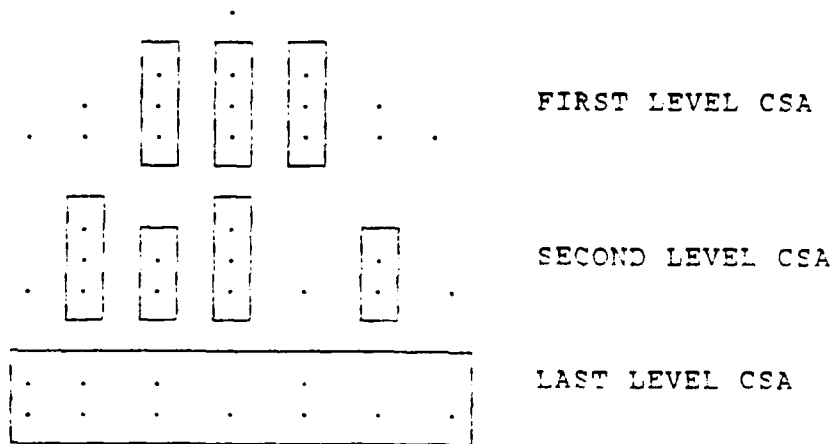

Figure 4.5 CSA Reduction 4X4 Multiplication

Once reduced to the last level addition, various CLA and pipelined ripple adder designs are available for increased performance.

2. 4 Bit Pipelined Multiplier Design

The 4 bit pipelined multiplier was designed using the Wallace Tree Structure, with D flip/flops inserted for pipelining. A block diagram of the module is shown in Figure 4.6. All partial products were generated simultaneously by the 16 AND gates. Next, the partial products were reduced using the Wallace Tree concept described in section 1. The final level additions were computed by a pipelined Genesil library 2 bit ripple adder and a 3 bit ripple adder.

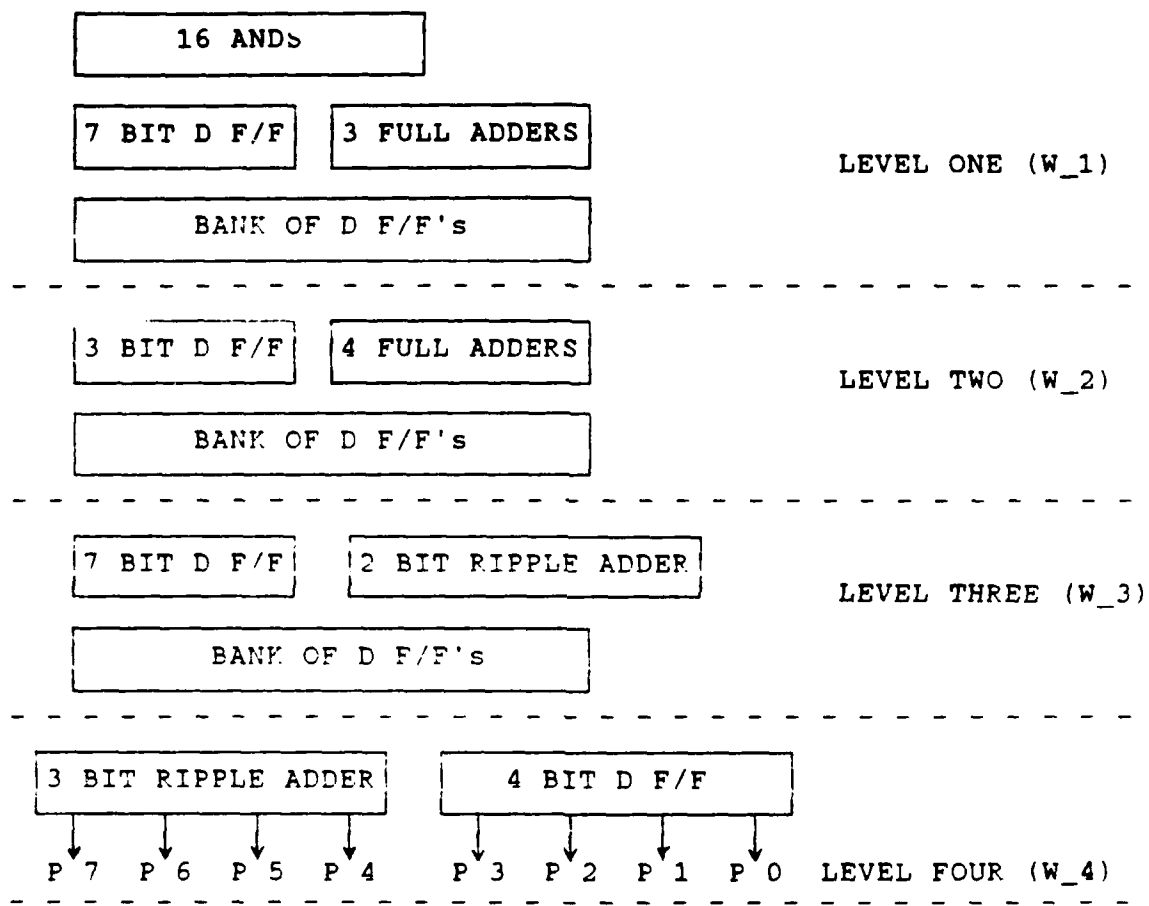

Figure 4.6 Custom 4 Bit Pipelined Multiplier Block Diagram

The module consisted of 4 blocks called W_1, W_2, W_3, and W_4. The module was attached to a chip, floorplanned, and simulated to test for correct logic. Figure 4.7 depicts the floorplan.

Figure 4.8 shows the 4 Bit Multiplier Chip with pads, clock, ground, and power. Timing analysis was performed by the system Timing Analyser for output propagation delays at each level. The results are presented in Table XII.

TABLE XII
4 BIT PIPELINED MULTIPLIER OUTPUT PROPAGATION DELAYS

BLOCK	OUTPUT PROPAGATION DELAYS (ns)	
	MIN	MAX
W_1	3.7	6.8
W_2	3.5	4.7
W_3	4.3	6.6
W_4	3.5	7.6

The data indicate that the longest output propagation delay was 7.6 ns, which occurred in block W_4.

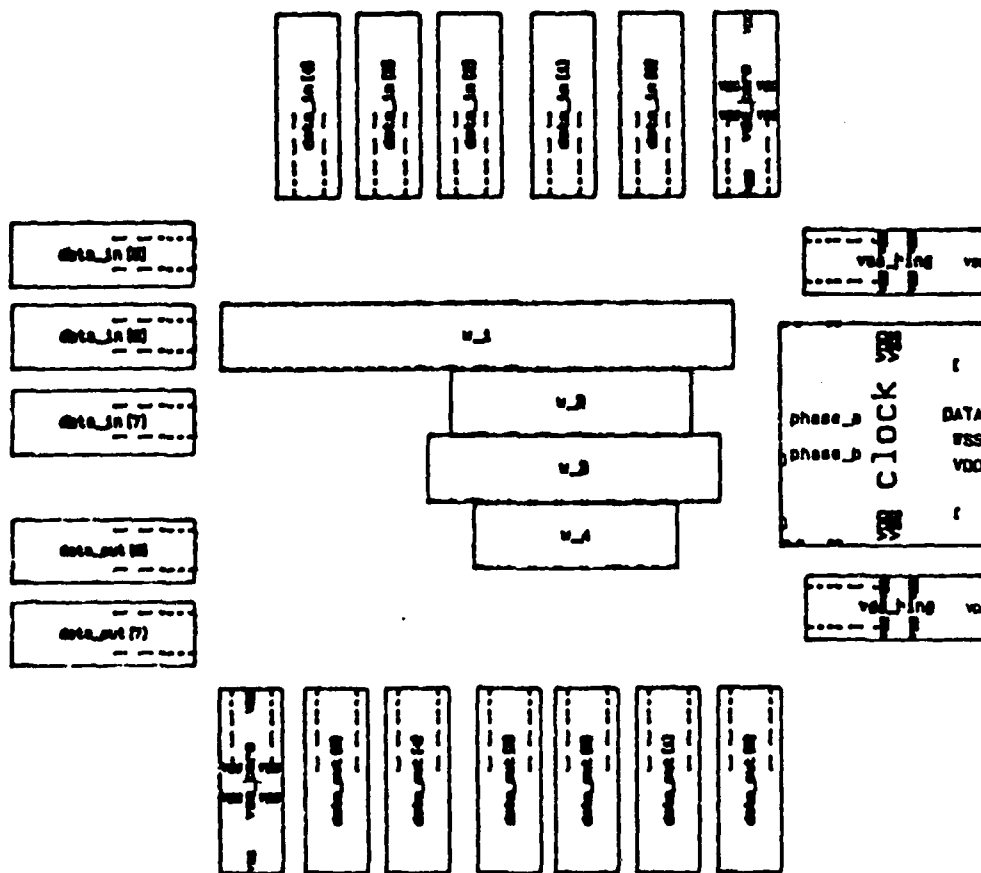

Figure 4.7 4 Bit Pipelined Multiplier Floorplan

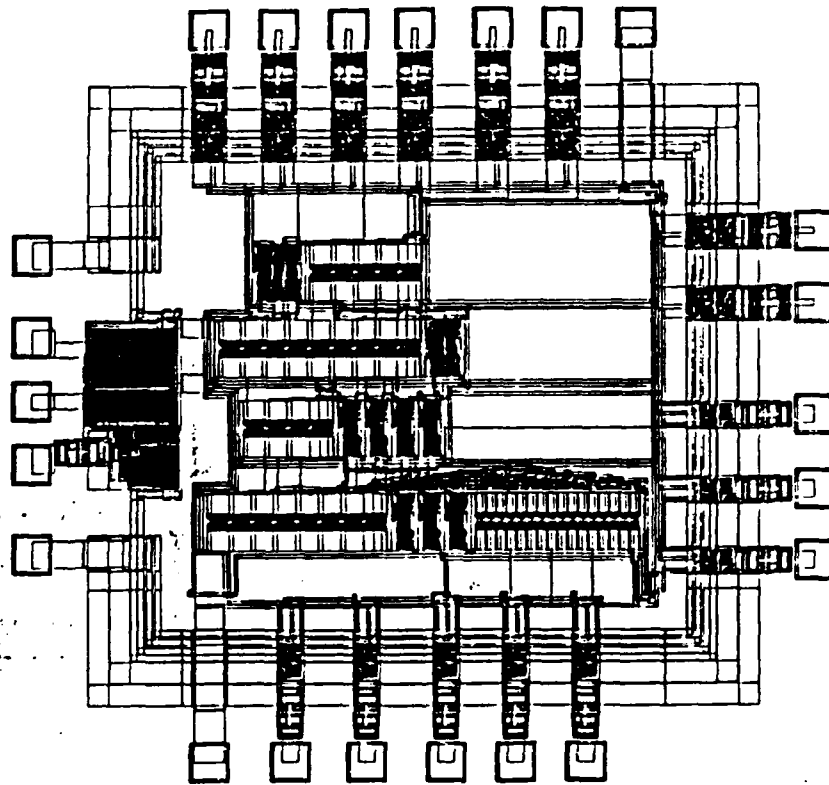

Figure 4.8 4 Bit Pipelined Multiplier Chip

D. 16 BIT PIPELINED MULTIPLIER

The purpose of the work reported in this section was to build a strictly high performance 16 bit pipelined multiplier chip which could be rapidly tested and de-bugged. Two designs were considered. They were the Wallace Tree structure and ripple adder design using a pipelined parallel multiplier with all partial products computed prior to array entry.

The Wallace Tree structure was rejected because, while it saved only two levels of logic, the design presented serious de-debugging difficulties. It was found to be extremely difficult to trace and debug signal errors when the column height was 16.

The design used was the pipelined parallel multiplier. The primary advantage of this design was found to be the relative ease of de-debugging the chip. The primary disadvantage was the additional cost in hardware and chip size associated with D flip/flop delays used to align and save intermediate results [Ref. 12:pp. 51-53].

1. 16 Bit Pipelined Multiplier Design

The 16 bit pipelined multiplier was designed using a pipelined parallel multiplier, and pipelined ripple carry adder hardware for summing the final partial products. A design block diagram is shown in Figure 4.9. All partial products were generated simultaneously by the 256 AND gates. This initial partial product generation is also necessary for the Wallace Tree structure. Partial product reduction can be

accomplished by Booth's modified algorithm and read only memories (ROM) [Ref. 19], but neither were pursued in this design. The partial products were then reduced with full adders, aligned, and rippled through the array with D flip/flops.

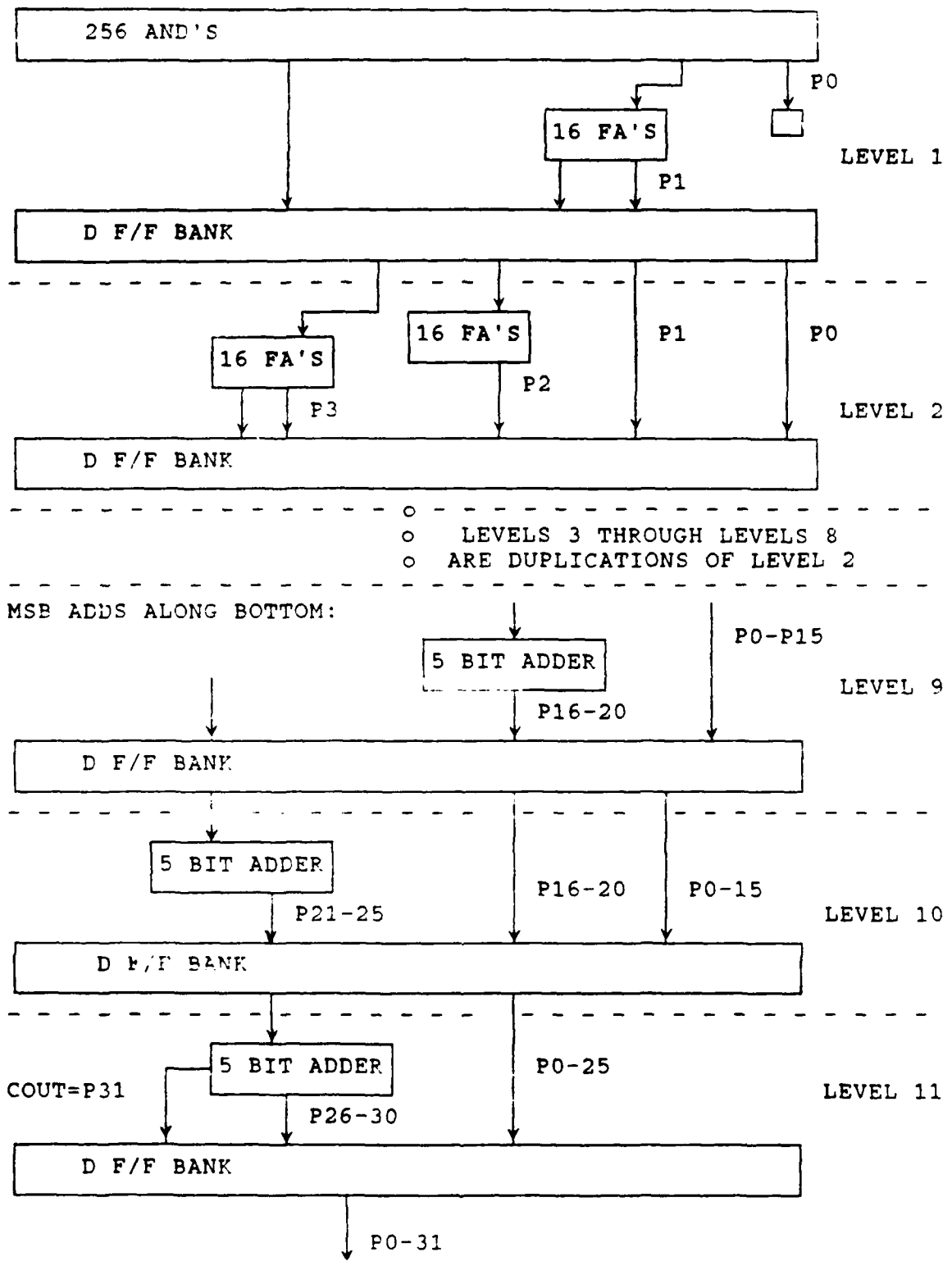

Figure 4.9 Custom 16 Bit Pipelined Multiplier Block Design

Eleven levels of blocks were used to construct the multiplier. These were then attached to a chip, which also included input/output pads, clock, power, and ground. The chip was then floorplanned, and the floorplan, with pads, is shown in Figure 4.10.

The chip was tested for correct logic using the system simulation feature. Ten to fifteen random 16 bit unsigned integers were inserted on the input signals. Although the tests run were not all inclusive, the results indicated correct logic for the inputs tested.

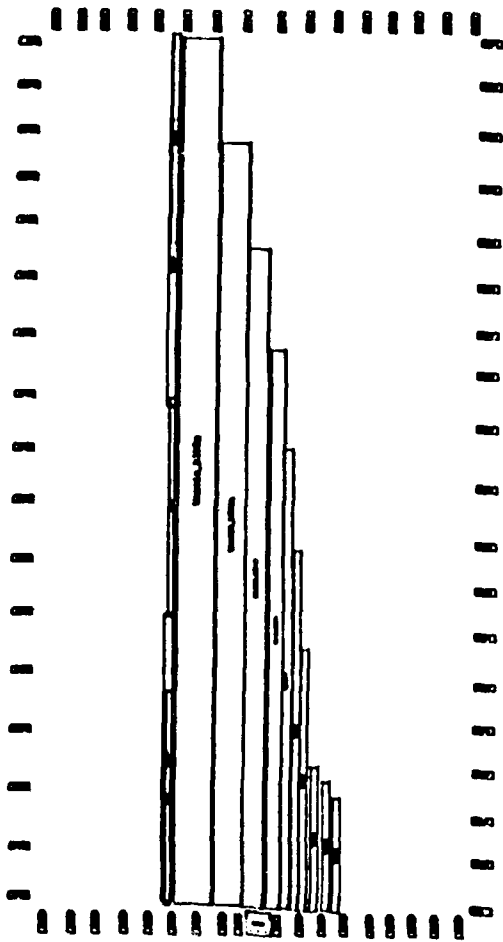

Figure 4.10 16 Bit Pipelined Multiplier Floorplan

Timing analysis was performed by the system Timing Analyser for output propagation delays at each level. The results are presented in Table XIII.

TABLE XIII
16 BIT PIPELINED MULTIPLIER OUTPUT PROPAGATION DELAYS

LEVEL	OUTPUT PROPAGATION DELAYS (ns)	
	MIN	MAX
1	4.7	5.8
2-8	7.2	10.4
9	7.9	8.1
10	7.9	8.1
11	7.9	8.1

The data indicate that the longest delay in the circuit is 10.4 ns, occurring in each level 2 through 8.

E. PERFORMANCE RESULTS

Table XIV is a summary of the performance results of the multipliers designed and constructed in this chapter.

TABLE XIV
MULTIPLIER PERFORMANCE RESULTS

	MAX DELAY (ns)	NO. OF STAGES	CLOCK RATE (MHZ)
4 BIT GENESIL (WITH LATCH)	10.9	1	57.4
8 BIT GENESIL (WITH LATCH)	24.4	1	32.3
16 BIT GENESIL (WITH LATCH)	51.0	1	17.3
4 BIT WALLACE (PIPELINED)	7.6	1	70.9
16 BIT PARALLEL (PIPELINED)	10.4	8	59.1

The data clearly illustrate the performance advantage gained by using the custom pipelined multipliers for high performance tasks.

V. CONCLUSIONS

A. SUMMARY

This thesis has described the applications of silicon compilers, and the design methodology of the Genesil Silicon Compiler. The Genesil Silicon Compiler methodology was demonstrated with the design and verification of custom pipelined adder and multiplier circuits.

The Genesil Silicon Compiler system is a rapid and efficient stand-alone tool for algorithm to hardware implementation and verification. Rapid iterative design, simulation, and timing analysis is possible because the system requires no user initiated programming.

The Genesil system user's manuals state that it is assumed the user has attended the Genesil Silicon Compiler user school. The manuals are reference manuals, and not tutorials for new users. The new user, however, can rapidly learn the system.

The user should thoroughly pre-plan design and performance specifications because there is not a plot "screen dump" capability on the system. The user must manually track and record all signal and object changes if an updated design plot is desired at the end of a session.

Object compiling and channel routing times for the circuits designed in this thesis were longer than anticipated. In order to expedite object compiling during design iterations

and de-bugging, object sizes (i.e., blocks, modules) should be as small as practicable. The system auto placement and routing features decreased routing times, but were less efficient than manual placement for overall object size.

Complete chips, with all associated hardware, consumed much system memory. During thesis research, chips and objects were stored on tape backups when memory availability became critical. All design and performance specifications can be verified at the block and module levels, which saves memory and routing time.

B. RECOMMENDATIONS

The following recommendations should be considered:

1. Research the area of optimum chip test algorithms prior to foundry tapeout. Investigate the full Genesis Compiler System Corporation's capabilities in the test area.
2. Purchase a plotter for plot "screen dumps" for rapid intermediate design schematics.
3. Transfer the system to the VAX 785 for more memory capability and faster tape storage capabilities.
4. Following system transfer to the VAX 785, establish a user custom library for high performance modules including pipelined integer multipliers, floating point multipliers, signed multipliers, and adders.
5. Do design, layout, simulation and Timing Analysis without pads for memory and routing time efficiency.

APPENDIX

GENESIL SILICON COMPILER TUTORIAL

A. INTRODUCTION

The purpose of this tutorial is to guide the new user through the mechanics of a Genesil system hierarchical top-down chip design. Designs may be implemented either top-down or bottom up. The tutorial begins with designing two basic blocks, followed by a multiplier module, and summarized with the design of a chip which uses the two blocks as its core.

Prior to beginning the initial session, the user should become familiar with the System Description Users Manual, in particular, Chapters 2 and 3. The next manual of interest is the System Description Application Commands manual, which contains detailed explanations of user invoked commands. The new user should periodically refer to Appendix A (Genesil System Menu Map) of the System Description Application Commands manual during initial sessions.

1. Design Method

All design and performance specifications should be pre-planned, including a detailed sketch with all signal names. The basic stand-alone object which can be attached to a chip is the block. Blocks may be attached to modules or chips, but not to other blocks. Modules, the intermediate object in the hierarchy, may be attached to other modules and

chips. There are no chip size constraints in the Genesil system, although this is dictated by the selected foundry. Large designs can, therefore, be implemented with chipsets.

2. Operating System

Genesil runs under the UNIX operating system. The user is referred to the UNIX For Genesil Users manual for detailed UNIX pathnames information. The pathname is the full name of an object in the Genesil system. The user is referred to page 4.8 in the System Description Users Manual for naming conventions details.

B. TUTORBLK_1 BLOCK

This section contains a step-by-step design of a block named `tutorblk_1`. The block will contain two random logic objects, which are a 4 bit adder (A0), and 5 bit D F/F (DFF1). The pre-planned schematic of the block, including all signal names is shown in Figure A.1.

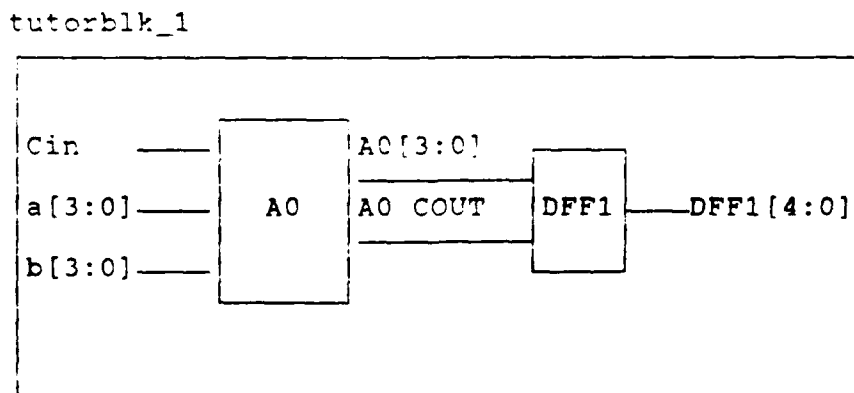

Figure A.1 Tutorblk_1

Since the system is menu driven, it is important to have a detailed schematic with signal names clearly marked. The same signal name cannot both enter and leave the same object.

All commands may be executed by typing in the command next to the prompt followed by a RETURN, by using the arrow buttons located on the upper right side of the keyboard to scroll through the commands followed by a RETURN, or by using the MOUSE. All following command instructions assume the user is using the MOUSE. The instruction select SOME_THING, means use the mouse to move the cross-hairs to SOME_THING and press the execute button (right hand button) on mouse.

1. While in the Executive menu (upper right corner of screen):

a. Following LOGIN and GENESIL entry, select CONTINUE.

b. Select SELECT_OBJECT (Figure A.2). This is normally always the initial command in order to attach objects to the user tree.

c. Select ATTACH (Figure A.3), followed by NEW (Figure A.4) since this block is the initial object.

d. Select BLOCK (Figure A.5) since this is the object type desired.

e. Next type in tutorblk_1, at the prompt followed by a <CR>. This is now the name of a new, yet to be defined, block, as indicated by the successful creation statement on the screen.

User ^gensettle/settle Executive
-----Genesis Version v7.0-----

) START Genesis job ^gensettle/settle/tutor_chip on microl
) Mon Aug 22 21 08 53 1988
)
) Genesis (tm) System Version v7.0
)
) Copyright Silicon Compiler Systems Corporation 1988
)
) Licensed Material -- Program Property of SCS -- All Rights Reserved
)
) This software is protected as an unpublished work and the copyright notice
) does not imply publication. This software contains confidential trade
) secrets of Silicon Compiler Systems Corporation. The reproduction,
) transfer or use of this software or the supporting documentation is
) governed by a license agreement with SCS, and the software shall be used
) solely in accordance with such agreement
)

RESTRICTED RIGHTS LEGEND

)
) Use, duplication or disclosure by the Government
) is subject to restrictions as set forth in
) subparagraph (c)(1)(ii) of the Rights in
) Technical Data and Computer Software clause
) at 252 227-7013
)
)

)
) CONTINUE
) EXIT_GENESIL
) CANCEL

) INSERT MESSAGES GRAPHICS OVERLAY RECORD UTILITY

) EXIT_GENESIL SELECT_OBJECT DEFINITION
) PACKAGE_EDIT

: .Figure A.2

```

-----
User  ^gensettle/settle                               Executive
-----Genesis Version v7.0-----

START Genesis job ^gensettle/settle/tutor_chip on microl
Mon Aug 22 21:08:53 1988
)
)                               Genesis (tm) System Version v7.0
)
)                               Copyright Silicon Compiler Systems Corporation 1988
)
)                               Licensed Material -- Program Property of SCS -- All Rights Reserved
)
) This software is protected as an unpublished work and the copyright notice
) does not imply publication. This software contains confidential trade
) secrets of Silicon Compiler Systems Corporation. The reproduction
) transfer or use of this software or the supporting documentation is
) governed by a license agreement with SCS, and the software shall be used
) solely in accordance with such agreement.
)
)                               RESTRICTED RIGHTS LEGEND
)
)                               Use, duplication or disclosure by the Government
)                               is subject to restrictions as set forth in
)                               subparagraph (c)(1)(ii) of the Rights in
)                               Technical Data and Computer Software clause
)                               at 252 227-7013
)
)
) CONTINUE
) EXIT_GENESIL
) CANCEL
) SELECT_OBJECT
) ATTACH
) NEW
) BLDOP
) tutorblk_1
) Successful Creation of ^gensettle/settle/tutorblk_1
-----
INSERT  MESSAGES  GRAPHICS                OVERLAY                RECORD                UTILITY
-----
BACK    UP          ACCOUNT          ATTACH          RENAME
CANCEL  DOWN         PATH           DETACH         DISPLAY
          SIDWAYS
-----

SELECT_OBJECT Option
: SELECT_OBJECT>

```

Figure A.3

```
.....
User: ^gensettle/settle                               Executive
-----Genesisil Version v7.0-----
```

```
) START Genesisil job ^gensettle/settle/tutor_chip on microl
) Mon Aug 22 21:08:53 1988
)
)                               Genesis (tm) System Version v7.0
)
)                               Copyright Silicon Compiler Systems Corporation 1988
)
)                               Licensed Material -- Program Property of SCS -- All Rights Reserved
)
) This software is protected as an unpublished work and the copyright notice
) does not imply publication. This software contains confidential trade
) secrets of Silicon Compiler Systems Corporation. The reproduction,
) transfer or use of this software or the supporting documentation is
) governed by a license agreement with SCS, and the software shall be used
) solely in accordance with such agreement.
)
)                               RESTRICTED RIGHTS LEGEND
)
)                               Use, duplication or disclosure by the Government
)                               is subject to restrictions as set forth in
)                               subparagraph (c)(1)(ii) of the Rights in
)                               Technical Data and Computer Software clause
)                               at 252 227-7013
)
)
) CONTINUE
) EXIT_GENESIL
) CANCEL
) SELECT_OBJECT
) ATTACH
```

```
-----
) INSERT MESSAGES GRAPHICS OVERLAY RECDRD UTILITY
)
) CANCEL EXISTING
) NEW
)
)-----
```

```
Enter ATTACH Option:
:SELECT_OBJECT>ATTACH>
```

Figure A.4

f. Select BACK, which returns the user to the main Executive menu.

g. Now select SELECT_OBJECT, and on the next screen select DOWN. The next screen should indicate a list of sub-objects on the right side of the screen (Figure A.6). Select tutorblk_1 and it will now be attached to the tree.

h. Now go BACK to the initial Executive menu (Figure A.2).

2. The block now needs to be defined:

a. Select DEFINITION (Figure A.2). The next screen is the initial Definition menu (Figure A.7) as denoted by the upper right hand corner of the screen. The upper left hand corner indicates the object types and pathnames.

b. Select HEADER (Figure A.7). The next screen (Figure A.8) is the Header form. Select RANDOM_LOGIC under Function type. CONFIRM it, then select VTC_CP10B under Fab line.

c. Next ACCEPT_FORM (Figure A.8) which will return the screen to the Definition menu. Now select SPECIFICATION which moves the screen to the RANDOM LOGIC Functional Specification form (Figure A.9).

d. Select NEW (Figure A.9), and a random logic library pops up on the right side of the screen. Select ADDER and DFF from the logic library.

```

*****
User: ^gensettle/settle                               Executive
-----Genesisil Version v7.0-----
) START Genesisil job ^gensettle/settle/tutor_chip on micro1
  Mon Aug 22 21 08:53 1988
/
/               Genesisil (tm) System Version v7.0
/
/   Copyright   Silicon Compiler Systems Corporation
/
/   Licensed Material -- Program Property of SCS -- All Rights Reserved
/
/ This software is protected as an unpublished work and the copysight
/ does not imply publication. This software contains confidential
/ secrets of Silicon Compiler Systems Corporation. The reproduction,
/ transfer or use of this software or the supporting documentation
/ governed by a license agreement with SCS, and the software shall be
/ solely in accordance with such agreement.
/
/               RESTRICTED RIGHTS LEGEND
/
/   Use, duplication or disclosure by the Government is subject to
/   restrictions as set forth in subparagraph (c)(1)(ii) of the Rights in
/   Technical Data and Computer Software clause at 252 227-7013
/
/   john
/   john_chip
/   lib_4bit_mult
/   mod_1
/   mod_4bitmult_lib
/   mult_4bit_lib
/   tut_mod2
/   tutorblk_1
/   tutorial_blk
/   tutorial_chip
/   tutorial_mod
/
CONTINUE
EXIT_GENESIL
CANCEL
SELECT_OBJECT
ATTACH
NEW
BLOCK
tutorblk_1
/ Successful Creation of ^gensettle/settle/tutorblk_1
DOWN
-----
INSERT  MESSAGES  GRAPHICS                OVERLAY  RECORD  UTILITY
-----
CANCEL
-----

```

```

Enter SELECT DOWN Path Name [string]
:SELECT_OBJECT:DOWN:tutorblk_1

```

Figure A.6

```

*****
General_Block ^gensettle/settle/tutorblk_1 Definition
----- Genesis Version v7.0 -----

```

Object Type: BLOCK

```

Function type
External          FCX_BLOCK          FIFO
Label            LPLA              LRAM
LROM             MULTIPLIER         PAD
Parallel_Datapath PLA              RAM
Random_Logic     ROM

```

Technology

```

Fab line
AMI_CT20A        GEN_CN20A          GEN_CN30A
GEN_CP12A        GES_CP12A         IMP_CP20A
NCR_CN20A        NSC_CN12A         NSC_CN20A
OPB_CN20A        RIC_CN20A         SSC_CN20A
US2_CN20A        VTC_CN16A         VTC_CP10B
VTC_CP12A        VTI_CN20A

```

```

Created By gensettle          Date Mon Aug 22 21 09 58 1988
Last Modified                Date Mon Aug 22 21 09 59 1988
Status

```

```

Compile parameters
COMPILER TYPE      STANDARD          NONE          ESTIMATE

```

Notes

```

:-----
:-----
:-----

```

```

-----
INSERT MESSAGES GRAPHICS FORM          OVERLAY          RECORD          UTILITY
ACCEPT FORM
CANCEL
-----

```

.DEFINITION HEADER:

Figure A.8

```

*****
Random_Logic ^gensettle/settle/tutorblk_1 Random Logic Block Editor
-----Genesis1 Version v7 0-----
RANDOM LOGIC Functional Specification

```

INSERT	MESSAGES	GRAPHICS	FORM	OVERLAY	RECORD	UTILITY
ACCEPT_FORM	CHECK_FORM	NEW			TEXT_SPEC	
PIGEONHOLE	SAVE	SIGNALS				
CANCEL	TECH_CHECK	UNUSE1				

DEFINITION:

Figure A,9

e. Now select BACK and the screen should be back in the RANDOM LOGIC Functional Specification form (Figure A.10) with the ADDER and DFF included.

f. Select EDIT, which is adjacent to ADDER0 (Figure A.10) and the next screen will be a specification form for the adder (Figure A.11). Details of all random logic specification forms are found in the Genesis Silicon Compiler Library Vol I, Blocks.

g. Fill in the adder specification form as shown in Figure A.12. Select EXPAND for a line-by-line entry form if desired and select COMPRESS to return.

h. Select NEXT (Figure A.12), which pulls up a specification menu for the DFF. Fill it out as shown in Figure A.13.

i. Now select BACK to return to the RANDOM LOGIC Functional Specification form (Figure A.10).

j. Select SIGNALS (Figure A.10) and the screen shows a signal list of the block. Make the signals correspond to Figure A.14 by selecting I, O and L next to the signal names. This cleans up the circuit because the system assumes the user desires Both normally.

k. Now select BACK to return to Figure A.10.

l. If desired, VIEW may now be selected for a block diagram, with signals, for inspection. Use BACK to return to the specification form.

```

*****
Random_Logic: ^gensettle/settle/tutorblk_1 Random Logic Block Editor
-----Genesis Version v7.0-----
RANDOM LOGIC Functional Specification

```

```

DEL EDIT MOVE 0: >ADDERG__ (ADDER)
DEL EDIT MOVE 1: >DFF1___ (DFF)

```

INSERT	MESSAGES	GRAPHICS	FORM	OVERLAY	RECORD	UTILITY
ACCEPT_FORM	CHECK_FORM	NEW	MATCH	MOVE_GROUP	VIEW	
PIGEONHOLE	SAVE	SIGNALS	UNUSED	DELETE_GROUP	TEXT_SPEC	
CANCEL	TECH_CHECK			EDIT_GROUP		

DEFINITION:

Figure A.10

```

*****
Random_Logic: ^gensettle/settle/tutorblk_1 Random Logic Block Editor
-----Genesis1 Version v7 0-----
Random Logic Block Specification

```

```

Block type  ADDER
Block index  C
Name        >ADDERO__
Width      >_4

```

Connector	Width	Regime		
		Timing		
A	4	1 Prop(t)	>FALSE*4	_____
B	4	1 Prop(t)	>FALSE*4	_____
OUT	4	1 Prop(t)	>NC*4	_____
CIN	1	1 Prop(t)	>FALSE	_____
COUT	1	1 Prop(t)	>NC	_____
FEED	4	1 Feedthru	>FALSE*4	_____

```

-----
INSERT MESSAGE GRAPHICS FORM OVERLAY RECORD UTILITY
-----
BACK NEXT EXPAND
-----

```

```

: DEFINITION

```

Figure A.11

```

*****
Random_Logic: ^gensettle/settle/tutorblk_1 Random Logic Block Editor
-----Genesil Version v7.0-----
Random Logic Block Specification

```

```

Block type: ADDER
Block index: 0
Name: >ADDERO__
Width: >_4

```

Connector	Width	Regime	Timing	Value
A	4	1	Prop(t)	>a[3:0]
B	4	1	Prop(t)	>b[3:0]
OUT	4	1	Prop(t)	>a0[3:0]
CIN	1	1	Prop(t)	>FALSE
COUT	1	1	Prop(t)	>a0cout
FEED	4	1	Feedthru	>FALSE*4

```

-----
INSERT  MESSAGES  GRAPHICS  FORM          OVERLAY  RECORD  UTILITY
-----
BACK           NEXT           EXPAND

```

DEFINITION:

Figure A.12

```

*****
Random_Logic: ^gensettle/settle/tutorblk_1      Random Logic Block Editor
-----Genesis Version v7.0-----
Random Logic Block Specification

```

```

Block type  DFF
Block index 1
Name        >DFF1_____
Width       >_5_____

```

Connector	Width	Regime	Timing	
PHX	1	1	Phase X	>phase_a_____
PHY	1	1	Phase Y	>phase_b_____
IN	5	1	Vy(t-1)	>a0cout.a0[3:0]_____
DUT	5	1	Sy(t)	>dff1[4:0]_____
LOAD	1	1	Vy(t-1)	>TRUE_____

```

-----
INSERT  MESSAGES  GRAPHICS  FORM          OVERLAY  RECORD  UTILITY
BACK          PREV          CONVERT      EXPAND
-----

```

.DEFINITION:

Figure A.13

```

*****
Random_Logic ^gensettle/settle/tutorblk_1 Random Logic Block Editor
-----Genesis1 Version v7.0-----
SIGNALS

```

```

New signal type      INPUT      OUTPUT      ID          LOCAL

Inputs
DEL IOBL 0a13 0) _____
DEL IOBL 0a13 0) _____
DEL IOBL 0phrase_a _____
DEL IOBL 0phrase_b _____

Outputs
DEL IOBL 0a003 0) _____
DEL IOBL 0a0cout _____
DEL IOBL 0a44.14 0) _____

```

```

-----
INSERT MESSAGES GRAPHICS FORM          OVERLAY      RECORD      UTILITY
-----
BACK                UNUSED          EXPAND
-----

Enter new signal names [string]
DEFINITION SIGNALS:

```

Figure A.14

m. Now select ACCEPT_FORM, and after the system writes the text file and validates the form, the screen should be back to the Executive menu (Figure A.15).

3. The block will now be compiled:

a. From Figure A.15 select COMPILE. The next screen gives the user various compile options including simulation, timing analysis, and layout. Since all will be used later, select BUILD_ALL (Figure A.16).

b. At completion of compile, the screen will again return to the Executive menu (Figure A.17).

4. The block will now be simulated. Detailed simulation information can be found in the Simulation Users Guide:

a. Select SIMULATION (Figure A.17).

b. Select GPL then SIMULATE on the Simulation Environment form (Figure A.18). Notice the system is now in the Functional Simulator (upper right hand corner of screen).

c. Select BIND (Figure A.19) to input signal values

d. Select MULTIPLE_SIGS (Figure A.20) since there are several signals to input.

e. Type in a[0] etc., and the value (0 or 1) as prompted. Use the values shown in Figure A.20 as initial examples.

f. When all desired signal values have been entered, select BACK (Figure A.20).

g. Now select CYCLE and 2 (Figure A.21) to cycle the system clocks twice.

```

.....
Random_Logic ^gensettle/settle/tutorblk_1                               Executive
-----Genesis Version v7.0-----
$ _L1 2: SIGNAL "a0E3 01,a0cout"
$ _L1 3: SIGNAL "dff1[4 0]"
) Created signal "dff1[4]"
) Created signal "dff1[3]"
) Created signal "dff1[2]"
) Created signal "dff1[1]"
) Created signal "dff1[0]"
$ _L1 0: SIGNAL "TRUE"
BACK
SIGNALS
OUTPUT_SIGNAL $ _L1 0: L
OUTPUT_SIGNAL $ _L1 1: L
CONFIRM
BACK
ACCEPT_FORM
: Text file is written
: This object is producible in all current technologies
: Form is valid
BACK
SELECT_OBJECT
SIDEWAYS
CANCEL
UP
ATTACH
NEW
BLOCK
tutorblk_2
: Successful Creation of ^gensettle/settle/tutorblk_2
DOWN
tutorblk_2
BACK
SELECT_OBJECT
SIDEWAYS
tutorblk_1
BACK
-----
INSERT  MESSAGES  GRAPHICS                                OVERLAY  RECORD  UTILITY
-----
EXIT_GENESIL  SELECT_OBJECT  DEFINITION  COMPILER  TOOLING
PACKAGE_EDIT  SIMULATION  PLG
TIMING
TRANSLATE
-----

```

Figure A,15

```

*****
Random_Logic: ^gensettle/settle/tutorblk_1                                Compile
-----Genesis1 Version v7 0-----
*_L1 0: SIGNAL "dff1[4:0]"
) Created signal "dff1[4]"
) Created signal "dff1[3]"
) Created signal "dff1[2]"
) Created signal "dff1[1]"
) Created signal "dff1[0]"
*_L1 0: SIGNAL "TRUE"
BACK
SIGNALS
OUTPUT_SIGNAL *_L1 0: L
OUTPUT_SIGNAL *_L1 1: L
CONFIRM
BACK
ACCEPT_FORM
) Text file is written
) This object is producible in all current technologies
) Form is valid
BACK
SELECT_OBJECT
SIDEWAYS
CANCEL
UP
ATTACH
NEW
BLOCK
tutorblk_2
) Successful Creation of ^gensettle/settle/tutorblk_2
OWN
tutorblk_2
BACK
SELECT_OBJECT
SIDEWAYS
tutorblk_1
BACK
COMPILE
-----
INSERT  MESSAGES  GRAPHICS  DVERLAY  RECORD  UTILITY
-----
CANCEL          SIM_MODEL    TA_MODEL    LAYOUT    CHECK_MODE_ON
BUILD_ALL      LOAD_MODEL

-----

)COMPILE

```

Figure A.16

```

*****
Random_Logic: ^gensettle/settle/tutorblk_1                               Executive
-----GenesisII Version v7.0-----
) done converting CMOS logic gate
) INFO *adding extra logic for mux node 1
) INFO *adding extra logic for mux node 10
) INFO *adding extra logic for mux node 13
) INFO *adding extra logic for mux node 17
) INFO *adding extra logic for mux node 20
) INFO *adding extra logic for mux node 21
) INFO *adding extra logic for mux node 30
) INFO *adding extra logic for mux node 33
) INFO *adding extra logic for mux node 40
) INFO *adding extra logic for mux node 43
) INFO CLOCK PAIR
) pha phase_a, phb phase_b
) *E_total = 0.15, E_cap=0.12, E_max=0.03 nJ
) *P_dc = 0.00 mW
) *P_ac = 1.50 mW @5.5V_0degC@10MHz (1.17 mW + 0.33 mW)
) *Total power dissipation= 1.50 mW @5.5V_0degC@10MHz
) Done with command COMPILE GATE SWITCH LVL MODEL -----in Block /tutorblk_1
) Times: real=15s, cpu=7.6s (u=5.2s, s=2.4s) (c=7.2s)
) Executing command COMPILE LOAD_MODEL -----in Block /tutorblk_1
) Capacitance for 'phase_a' is 0.06 pf
) Capacitance for 'phase_b' is 0.34 pf
) I_Peak AC current to VSS 12844 uA
) Key Parameters: 212 transistors, Dissipation: 1.5 milliwatts@5V@10MHz
) Key Parameters (set 124) Modified
) Done with command COMPILE LOAD_MODEL -----in Block /tutorblk_1
) Times: real=47s, cpu=23s (u=16s, s=7.3s) (c=23s)
) Executing command MARK SIMULATOR BLOCK MODEL-----in Block /tutorblk_1
) Loading model for type RL
) Generating model for /mnt/gen/gensettle/settle/tutorblk_1 type RL
) Done with command MARK SIMULATOR BLOCK MODEL-----in Block /tutorblk_1
) Times: real=31s, cpu=11s (u=6.8s, s=4.4s) (c=10s)
) Done with command BUILD_ALL
-----
INSERT  MESSAGES  GRAPHICS  OVERLAY  RECORD  UTILIT
-----
EXIT_GENESIL  SELECT_OBJECT  DEFINITION  COMPILER  TOOLING
                PACKAGE_EDIT  SIMULATION  PLOT
                TIMING          TRANSLATE
-----

```

Figure A.17

```

*****
Random_Logic: ^gensettle/settle/tutorblk_1 Functional Simulator
              Genesis Version v7.0-----
              Simulation Environment
-----

```

```

Setup Files      Comment
> _____ > _____
-----

```

```

Screen Definition Files Comment
> _____ > _____
-----

```

```

Test Vector Files Comment
> _____ > _____
-----

```

```

(help genie/<topic>) - help on genie, try help genie/help
(help sim/<topic>) - help on simulator
(help sim/setup) - help on setup
Some simulator commands
(pi inst) - print instance(block,module), shows connections
(pn net) - print net, shows connections
(cc count) - clock count times
(ss count) - step count times
(isn net) - gets value of net as binary string
(isn net) - gets value of net as hex string
(whodrives net) - show values of drivers on net

sn and snc no longer using binding strengths
see the help info if you need the old behavior

```

```

-----
INSERT  MESSAGE  GRAPHICS  FORM          OVERLAY  RECORD  UTILITY
-----
EXIT_SIM          SIMULATE          GFL
                  FLATGFL
                  FLATSGFL
                  GSL
-----

```

```

Command
:SIMULATION:

```

Figure A.18

```

*****
Random_Logic ^gensettle/settle/tutorblk_1 Functional Simulator
-----Genesil Version v7.0-----
) INFO CLOCK PAIR
) pha phase_a phb phase_b
) *E_total = 0.15 E_cap=0.12 E_imag=0.03 nJ
) *P_dc = 0.00 mW
) *P_ac = 1.50 mW @5.5v_OdegC@10MHz(1.17 mW + 0.33 mW)
) *Total power dissipation= 1.50 mW @5.5v_OdegC@10MHz
) Done with command COMPILE GATE SWITCH LVL MODEL -----in Block /tutorblk_1
) Times: real=15s, cpu=7.6s (u=5.2s, s=2.4s) (c=7.2s)
) Executing command COMPILE LOAD_MODEL -----in Block /tutorblk_1
)
) Capacitance for 'phase_a' is 0.06 pf.
) Capacitance for 'phase_b' is 0.34 pf.
) I_Peak AC current to VSS: 12844 uA
) Key Parameters: 212 transistors, Dissipation: 1.5 milliWatts@5v@10MHz
) Key Parameters (set 124) Modified
) Done with command COMPILE LOAD_MODEL -----in Block /tutorblk_1
) Times: real=47s, cpu=23s (u=16s, s=7.3s) (c=23s)
) Executing command MARK SIMULATOR BLOCK MODEL-----in Block /tutorblk_1
)
) loading model for type RL
) Generating model for /mnt/gen/gensettle/settle/tutorblk_1 type RL
) Done with command MARK SIMULATOR BLOCK MODEL-----in Block /tutorblk_1
) Times: real=31s, cpu=11s (u=6.8s, s=4.4s) (c=10s)
) Done with command BUILD_ALL
SIMULATION
GFL
) Selecting Functional Model
) SIMULATE
) Checking file currency
) Internal Object Hierarchy Initialized
) Completing Data Gathering Phase
) All files are up to date
) Done with currency check
) Linking sim model
) phasea= phase_a phaseb= phase_b
-----
INSERT  MESSAGES  GRAPHICS  OVERLAY  RECORD  UTILITY
-----
BACK    QUERY      HIER_LEVEL  ENVIRONMENT  NEWSSCREENS
BIND    CYCLE      RUN_VECTORS  SCROLL      FILE_SCREEN
ASSET   STEP       UNBIND      VERIFY_VALUE  FORMAT_SCREEN
-----
Command
:SIMULATION:

```

Figure A.19

```

*****
Random_Logic ^gensettle/settle/tutorblk_1 Functional Simulator
-----Genesis Version v7.0-----
)
) Loading model for type RL
) Generating model for /mnt/gen/gensettle/settle/tutorblk_1 type RL
) Done with command MARK_SIMULATOR_BLOCK_MODEL-----in Block /tutorblk_1
) Times real=31s, cpu=11s (u=6.8s, s=4.4s) (c=10s)
) Done with command BUILD_ALL.
SIMULATION
GFL
) Selecting Functional Model
SIMULATE
) Checking file currency
) Internal Object Hierarchy Initialized....
) Completing Data Gathering Phase ....
) All files are up to date
) Done with currency check
) Linking sim model
) phasea= phase_a phaseb= phase_b
BINC
MULTIPLE_SIGS
a[0]
0
a[1]
1
a[2]
0
a[3]
1
[0]
0
b[1]
0
b[2]
0
b[3]
1
-----
INSERT MESSAGES GRAPHICS OVEPLAY RECORD UTILITY
-----
B404 MULTIPLE_SIGS CHOOSE_SIGS
MOVE_DOWN
MOVE_UP
-----
next to DIND
SIMULATION

```

Figure A.20

```

*****
Random_Logic ~gensettle/settle/tutorblk_1 Functional Simulator
-----Genesisil Version v7.0-----
) Done with command MARK SIMULATOR BLOCK MODEL-----in Block /tutorblk_1
) Times real=31s. cpu=11s (u=6 Bs. s=4 4s) (c=10s)
) Done with command BUILD_ALL
SIMULATION
OF_
) Selecting Functional Model
SIMULATE
) Checking file currency
) Internal Object Hierarchy Initialized...
) Completing Data Gathering Phase ....
) All files are up to date
) Done with currency check
) Linking sim model
/ phasea= phase_a phaseb= phase_b
EIND
MULTIPLE_SIGS
a[0]
C
a[1]
1
a[2]
C
a[3]
1
b[0]
C
b[1]
C
b[2]
1
BACK
CYCLE
2
-----
INSERT  MESSAGES  GRAPHICS  OVERLAY  RECORD  UTILITY
-----
BACK    QUERY      HIER_LEVEL  ENVIRONMENT  NEWSSCREENS
EIND    CYCLE      RUN_VECTORS  SCROLL       PICK_SCREEN
ASSERT  STEP        UNBIND      FORMAT_SCREEN
        PROPAGATE  VERIFY_VALUE
-----

```

Command
SIMULATION: p1

Figure A.21

h. Type in pi and depress RETURN (Figure A.21).

i. Now the screen should look like Figure A.22.

which has simulated the block for proper logic. Other values may be inserted by using the previous steps beginning with c.

j. Now select BACK, then EXIT_SIM, with a CONFIRM to return to the Executive menu (Figure A.17)

5. Timing analysis will now be performed on the block. The Timing Analysis Users Guide contains detailed information concerning timing data and commands:

a. Select TIMING (Figure A.17).

b. The system should be in the Timing Analyser function as shown in Figure A.23.

c. Select CLOCKS, and all object clock information is as shown in Figure A.24.

d. Select BACK (Figure A.24).

e. Select PATH_DELAY (Figure A.23). The screen now shows a list of all user generated nodes or signals (Figure A.25). By selecting source and destination signals from the list, the system calculates logic propagation delays between the selected nodes (Figure A.26). This is where the detailed schematic may be useful.

f. Select BACK (Figure A.26) to get to Figure A.23, then BACK to exit timing, followed by CONFIRM.

```

*****
Random_Logic ^gensettle/settle/tutorblk_1 Functional Simulator
-----Genesis Version v7 0-----
) loading model for type RL
) Generating model for /mnt/gen/gensettle/settle/tutorblk_1 type RL
) Done with command MARK SIMULATOR BLOCK MODEL-----in Block ^tutorblk_1
) Times real=31s. cpu=11s (u=6 9s. s=4 3s) (c=10s)
) Done with currency check
) Linking sim model
) phasea= phase_a phaseb= phase_b
BIND
MULTIPLE_SIGS
a[0]
0
a[1]
1
a[2]
0
a[3]
1
b[0]
)
b[1]
0
b[2]
1
b[3]
)
BACK
CYCLE

P:
) tutorblk_1 is of type genblock/rl with 10 ports
) port 0 CI phase_a to NC#1
) port 1 CI phase_b to NC#0
) port 2 C dff1(A 0) to NC#5 = 10111
) port 3 I a[0] 0) to NC#4 = 1010
) port 4 I b[0] 0) to NC#4 = 1101
-----
INERT  MESSAGES  GRAPHICS  OVERLAY  RECORD  UTILITY
-----
BACK  Q ER*  HIER_LEVEL  ENVIRONMENT  NEWSSCREENS
BIND  CYCLE  RUN_VECTORS  SCROLL  PICK_SCREEN
ASSERT  STEP  UNBIND  FORMAT_SCREEN
PF0FASATE  VERIFY_VALUE
-----
Command
SIMULATION.

```

Figure A.22

```

*****
Random_Logic: ^gensettle/settle/tutorblk_1                               Timing Analyzer
-----Genesil Version v7.0-----

```

TIMING ANALYSIS REPORT

```

Object Type: BLOCK                               Function Type: Random_Logic
Technology: C1                                   Fab Line: VTC_CP10B

```

```

Setup Files
index file_name          comment          include
0 > _____

```

```

Process Corner
  GUARANTEED          TYPICAL

```

```

Operating Conditions
  Junction temperature --- Supply voltage ---

```

```

Current Clock Definition
  Phase 1 ---          Phase 2 ---

```

```

-----
INSEAT  MESSAGES  GRAPHICS  FORM          OVERLAY          RECORD          UTILITY
BACK    CLEAR_SETUPS  CLOCKS    SETUP_HOLD     OUTPUT_DELAY     DISABLE_CURRENT
        READ_SETUPS   NODE_SETUP  SETUP_HOLD     PATH_DELAY       VIOLATIONS

```

!TIMING!

Figure A.23

```

*****
Random_Logic ^gensettle/settle/tutorbit_1 Timing Analyzer
-----Genesis Version v7 0-----
CLOCK REPORT MODE
-----
Fabline VTC_CP10B Corner TYPICAL
Junction Temperature 75 degree C Voltage 5 00v
Phase 1 phase_a Phase 2 phase_b
Included setup files default setup file
-----
CLOCK TIMES (minimum)
Phase 1 High: --- ns Phase 2 High 10 9 ns
Cycle (from Ph1) 10 9 ns Cycle (from Ph2) 21 5 ns
Minimum Cycle Time 21 5 ns Symmetric Cycle Time 21 7 ns
-----
CLOCK WORST CASE PATHS
Minimum Phase 2 high time is 10 9 ns set by
Node Cumulative Delay Transition
(internal) 10 9 rise
a0cout 9 5 fall
a[0] 0 0 fall
Minimum cycle time (from Ph1) is 10 9 ns set by
Node Cumulative Delay Transition
(internal) 10 9 rise
a0cout 9 5 fall
a[0] 0 0 fall
Minimum cycle time (from Ph2) is 21 5 ns set by
** Clock delay 1 2ns (10-10 7) cycle_sharing disabled
Node Cumulative Delay Transition
INSERT MESSAGES GRAPHICS FORM OVERLAY RECORD UTILITY
-----
BACK PHASE2_HIGH CYCLE_PH1 DUMP_LATCH_THRESHOLD
CYCLE_PHE DUMP_LATCH
-----

```

BTIMING CLOCKS.

Figure A.24

```

*****
Random_Logic: ^gensettle/settle/tutorblk_1 Timing Analyzer
-----Genesis Version v7.0-----
PATH DELAY MODE : NODE_NAME
-----
Fabline VTC_CP10B Corner TYPICAL :a[0]
Junction Temperature: 75 degree C Voltage 5.00v :a[1]
Phase 1: phase_a Phase 2: phase_b :a[2]
Included setup files: default setup file :a[3]
-----
Source Destination PATH DELAY (ns) :a[0]
: Min Max Ph1 Delay Ph2 Delay :a[1]
:a[2]
:a[3]
a[0] a[0] 3.8 4.2 3.8 4.2 PA:b[0]
a[1] a[1] 3.8 5.0 3.8 5.0 PA:b[1]
a[2] a[2] 3.8 5.1 3.8 5.1 PA:b[2]
a[3] a[3] 3.9 5.1 3.9 5.1 PA:b[3]
-----
:df[1][0]
:df[1][1]
:df[1][2]
:df[1][3]
:df[1][4]
:phase_a
:phase_b
-----
INSERT MESSAGES GRAPHICS FORM OVERLAY RECORD UTILITY
-----
BACK PATH_DELETE_TOGGLE
-----
Enter (string)
:TIMING:PATH_DELAY:

```

Figure A.26

6. Now to exit Genesisl:

a. Select EXIT_GENESIL (Figure A.15).

b. Select CONFIRM.

c. Select appropriate log command. The block is stored in the user's account regardless of which log command is selected. It is best to not save the log in the interest of memory, unless a future printout is desired.

C. TUTORBLK_2 BLOCK

This section is a user exercise to build a block named tutorblk_2 by following the steps illustrated in section B. This block is necessary for the completion of the chip in section E.

The block will contain six random logic objects, consisting of 5 inverters (i0-i4) and a 5 bit D F/F (DFF5). The pre-planned schematic of the block, including all necessary signal names is shown in Figure A.27.

tutorblk.2

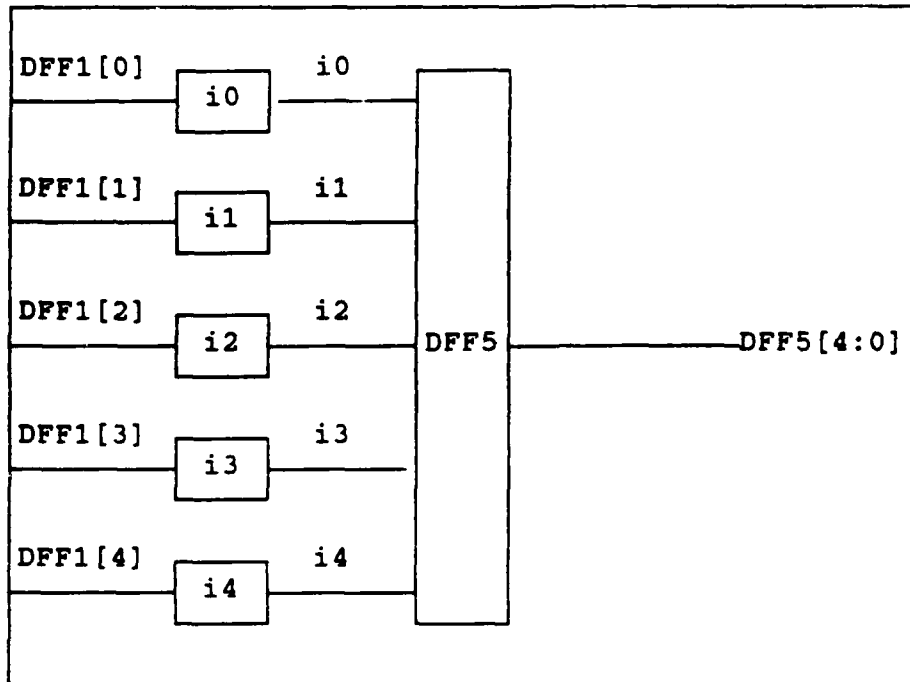

Figure A.27 Tutorblk_2

To ensure that the block functions properly and will connect properly to the chip, make the specification menus match Figure A.28 through A.32. Then compile, simulate, and perform timing analysis as in section B.

 Random_Logic ^gensettle/settle/tutorblt_2 Random Logic Block Editor
 -----General Version v7.0-----

RANDDM LOGIC Functional Specification:

DEL EDIT MOVE 0: >INVERT0_ (INVERT)
 DEL EDIT MOVE 1: >INVERT1_ (INVERT)
 DEL EDIT MOVE 2: >INVERT2_ (INVERT)
 DEL EDIT MOVE 3: >INVERT3_ (INVERT)
 DEL EDIT MOVE 4: >INVERT4_ (INVERT)
 DEL EDIT MOVE 5: >DFF5___ (DFF)

INSERT	MESSAGES	GRAPHICS	FORM	OVERLAY	RECORD	UTILITY
ACCEPT_FORM	CHECK_FORM	NEW	MOVE_GROUP	VIEW		
PIGEONHOLE	SAVE	SIGNALS	DELETE_GROUP	TEXT_SPEC		
CANCEL	TECH_CHECK	UNUSED	EDIT_GROUP			

>DEFINITION>

Figure A.28

```

.....
Random_Logic ^gensettle/settle/tutorblk_2 Random Logic Block Editor
-----Genesil Version v7.0-----
Random Logic Block Specification

```

```

Block type INVERT
Block index 0
Name D:INVERTO_
Drive Strength >1

```

```

          Regime
Connector Width | Timing
IN         1     | 1 Prop(t) >df#1E0J_____
OUT        1     | 1 Prop(t) >iO_____

```

```

-----
INSERT MESSAGEE GRAPHICS FORM OVERLAY RECORD UTILITY
-----
BACK NEXT EXPAND
-----

```

DEFINITION

Figure A.29

 Random_Logic. ^gensettle/settle/tutorblk_2 Random Logic Block Editor
 -----Genesis Version v7.0-----
 Random Logic Block Specification

Block type: DFF
 Block index: 5
 Name: >DFF5____
 Width: >_5

Connector	Width	Regime		
		Timing		
PHX	1	1 Phase X		>phase_a_____
PHY	1	1 Phase Y		>phase_b_____
IN	5	1 Vy(t-1)		>14,13,12,11,10_____
OUT	5	1 Sy(t)		>dff5[4:0]_____
LOAD	1	1 Vy(t-1)		>TRUE_____

 INSERT MESSAGES GRAPHICS FORM OVERLAY RECORD UTILITY

 BACK PREV CONVERT EXPAND

DEFINITIONS

Figure A.30

```

*****
Random_Logic ^gensettle/settle/tutorblk_2 Random Logic Block Editor
-----Genesisil Version v7.0-----
Random Logic Block Specification

```

```

Block type DFF
Block index 5
Name >>DFF5_____
Width >>5_____

```

Connector	Width	Regime	Timing		
PHX	1	1	Phase X	[0]	>phase_a_____
PHY	1	1	Phase Y	[0]	>phase_b_____
IN	5	1	$V_q(t-1)$	[4]	>i4_____
				[3]	>i3_____
				[2]	>i2_____
				[1]	>i1_____
				[0]	>i0_____
OUT	5	1	$S_q(t)$	[4]	>dff5[4]_____
				[3]	>dff5[3]_____
				[2]	>dff5[2]_____
				[1]	>dff5[1]_____
LOAD	1	1	$V_q(t-1)$	[0]	>dff5[0]_____
				[0]	>TRUE_____

```

-----
INSECT  MESSAGES  GRAPHICS  FORM          OVERLAY  RECORD  UTILITY
BACK          PREV          CONVERT    COMPRESS
-----

```

: DEFINITION:

Figure A.31

```

*****
Random_Logic ^gensettle/settle/tutorbla_2 Random Logic Block Editor
-----Genesis Version v7.0-----
SIGNALS

```

```

New signal type INPUT OUTPUT IO LOCAL

```

```

Inputs
DEL IOBL >dff1[4] _____
DEL IOBL >dff1[3] _____
DEL IOBL >dff1[2] _____
DEL IOBL >dff1[1] _____
DEL IOBL >dff1[0] _____
DEL IOBL >phase_a _____
DEL IOBL >phase_b _____

```

```

Outputs
DEL IOBL >dff5[4] _____
DEL IOBL >dff5[3] _____
DEL IOBL >dff5[2] _____
DEL IOBL >dff5[1] _____
DEL IOBL >dff5[0] _____

```

```

Locals
DEL IOBL >:0 _____
DEL IOBL >:1 _____
DEL IOBL >:2 _____
DEL IOBL >:3 _____
DEL IOBL >:4 _____

```

```

-----
INSERT MESSAGES GRAPHICS FORM OVERLAY RECORD UTILITY
-----
BACK UNUSED COMPRESS
-----

```

```

Enter new signal name s: (string)
: DEFINITION: SIGNALS.

```

Figure A.32

D. MULT_MOD MODULE

This section illustrates the design of a 4 bit multiplier module. The detailed schematic is shown in Figure A.33.

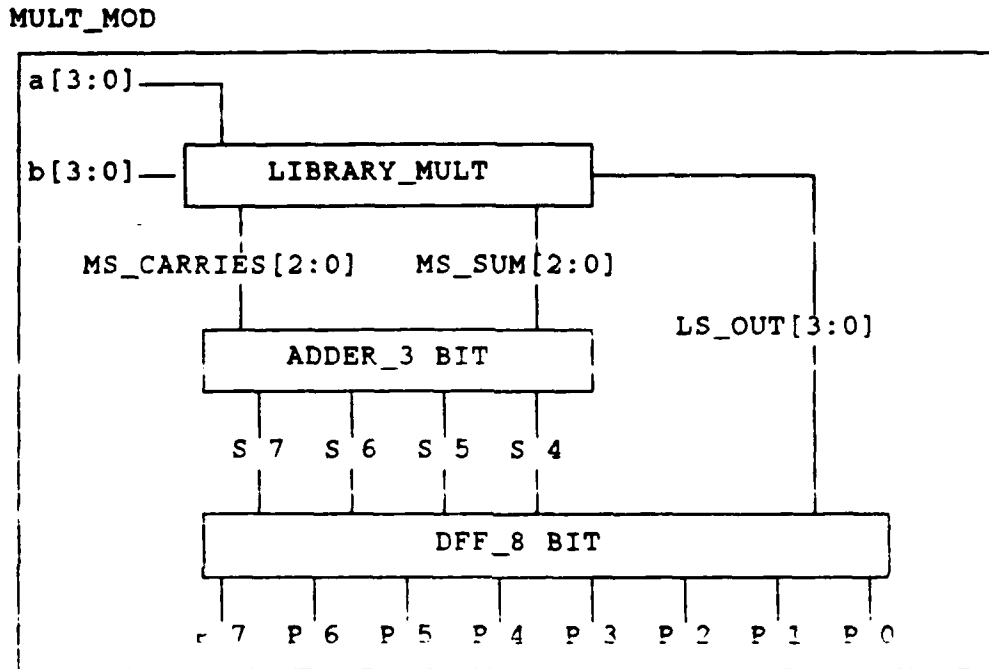

Figure A.33 Mult_Mod Module

Library_mult is a Genesil system library parallel multiplier block. The external adder is necessary to complete the multiplication. Detailed information concerning the multiplier block is contained in the Genesil Silicon Compiler Library Volume I, Blocks.

1. The user should proceed as in the previous sections up through ATTACH NEW (Figure A.5):

- a. Now select GENERAL_MODULE (Figure A.5).

b. Go BACK, name the module Mult_Mod, by typing it in next to the prompt, and attach it to the tree as in the previous sections.

c. Select DEFINITION from the Executive menu.

d. Select HEADER (Figure A.34), then VTC_CP10B for Fab line, and ACCEPT_FORM.

e. Now select SPECIFICATION to pull up the Module specification menu. No objects are on the menu yet.

f. Select ATTACH_NEW, then RANDOM_LOGIC. The user will now be prompted for a name. Name the first random logic object adder_3bit.

g. Repeat for dff_8bit.

h. Now select ATTACH_NEW, then select BLOCK, and name it library_mult when prompted. When complete, the screen should look like Figure A.35.

i. Each sub_object (adder_3bit, dff_8bit, and library_mult) must now be defined.

j. Starting with adder_3bit, select DEFINE (Figure A.35). Then select HEADER and specify RANDOM_LOGIC for object type on the Header form. Fab line can be specified, but will be automatically taken care of at the module level. Select ACCEPT_FORM.

k. Next select SPECIFICATION which pulls up a RANDOM LOGIC Functional Specification Menu. Select NEW, then ADDER from the menu provided.

```

*****
Module ^gensettle/settle/tutorial_mod Definition
-----Genesisil Version v7.0-----

```

Module Type: GENERAL

Technology: CMOS-1

Feb line:

AMI_CT20A	GEN_CN20A	GEN_CN30A
GEN_CP12A	GES_CP12A	IMP_CP20A
NCR_CN20A	NSC_CN12A	NSC_CN20A
DRB_CN20A	RIC_CN20A	SSC_CN20A
US2_CN20A	VTC_CN16A	VTC_CP10B
VTC_CP12A	VTI_CN20A	

Created By gensettle

Date: Mon Aug 22 15 40 26 1988

Last Modified

Date: Mon Aug 22 17 35 45 1988

Status

Placed

Yes

Routed :

No

Compile parameters:

COMPILER TYPE

STANDARD

NONE

ESTIMATE

Power Adjuster >1 00_ (multiplier)

Flatten

(OFF, ON)

Estimate (OFF, POWER, CLOCK, BUS, ALL)

Notes

```

>This is a general module which will be constructed top down. The mod_
>will contain a library 4 bit multiplier, 3 bit ripple adder, and
>D_#/#'s
>
>
>
>

```

```

-----
INSERT MESSAGES GRAPHICS FORM OVERLAY RECORD UTILITY
ACCEPT FORM
CANCEL
-----

```

.DEFINITION>HEADER>

Figure A.34

```

.....
Module: ^gensettle/settle/tutorial_mod                                     Definition
-----Genesisil Version v7 0-----
Sub-Objects Name Type
>adder_3bit Random_Logic DEFINE DETACH
>dff_8bit Random_Logic DEFINE DETACH
>library_mult MULTIPLIER DEFINE DETACH
-----
ATTACH_NEW ATTACH_EXISTING
-----

```

```

-----
INSERT MESSAGES GRAPHICS FORM OVERLAY RECORD UTILITY
-----
ACCEPT_FORM HEADER ATTACH NET_NETLIST
OBJECT_NETLIST
-----

```

:DEFINITION:

Figure A.35

1. Go BACK to the Specification menu and it should look like Figure A.36.

m. Now select EDIT, and fill out the Random Logic Block Specification menu as shown in Figure A.37. Select EXPAND and the menu should look like Figure A.38.

n. Starting at step j, follow the same procedures with dff_8bit. The RANDOM LOGIC Functional Specification form (Figure A.39) and Random Logic Block Specification form (Figure A.40) should be filled out as shown.

o. Proceed the same way for library_mult, but remember to select multiplier on the Header form.

p. Fill out the MULTIPLIER SPECIFICATION menu as shown in Figure A.41.

q. Select ACCEPT_FORM (Figure A.41), then BACK to the Module Specification Form (Figure A.35).

2. The module must now be netlisted:

a. Select OBJECT_NETLIST (Figure A.35).

b. Type in adder_3bit (Figure A.42) next to Object Name. Another way to do this is to mouse Object Name, depress Return, and a list of sub-Objects is pulled up on the right side of the screen for selection.

c. Proceed through the Net Name list, and select E. next to attributes, for external for all signals. This is necessary to make the module function correctly!

d. Select Object Name, and type in dff_8bit (Figure A.42). Do the same as in c above.

```

*****
Random_Logic: <nsettle/settle/tutorial_mod/adder_3bit Random Logic Block Editor
-----Genesisil Version v7.0-----

```

RANDOM LOGIC Functional Specification:

```

DEL  EDIT  MOVE  0  >ADDERO__  (ADDER)

```

INSERT	MESSAGES	GRAPHICS	FORM	OVERLAY	RECORD	UTILITY
ACCEPT_FORM	CHECK_FORM	NEW	DELETED_GROUP	VIEW		
PIGEONHOLE	SAVE	SIGNALS	EDIT_GROUP	TEXT_SPEC		
CANCEL	TECH_CHECK	UNUSED				

```

:DEFINITION:DEFINED>

```

Figure A.36

```

*****
Random_Logic: <nsettle/settle/tutorial_mod/adder_3bit Random Logic Block Editor
-----Genesis1 Version v7.0-----
Random Logic Block Specification

```

```

Block type:  ADDER
Block index: 0
Name:         >ADDERO__
Width:       >_3

```

Connector	Width	Regime	Timing	Value
A	3	1 Prop(t)		>MS_SUM[2:0]
B	3	1 Prop(t)		>MS_CARRIES[2:0]
OUT	3	1 Prop(t)		>s6, s5, s4
CIN	1	1 Prop(t)		>FALSE
COU	1	1 Prop(t)		>s7
FEED	3	1 Feedthru		>FALSE*3

```

-----
INSERT  MESSAGES  GRAPHICS  FORM          OVERLAY  RECORD  UTILITY
-----
BACK                               EXPAND
-----

```

```

DEFINITIONS DEFINED

```

Figure A.37

```

*****
Random_Logic <nsettle/settle/tutorial_mod/adder_3bit Random Logic Block Editor
-----Genesis1 Version v7.0-----
Random Logic Block Specification

```

```

Block type  ADDER
Block index  0
Name         >ADDER0__
Width       >_3

```

Connector	Width	Regime			
		Timing			
A	3	1 Prop(t)	[2]	>MS_SUM[2]	_____
			[1]	>MS_SUM[1]	_____
			[0]	>MS_SUM[0]	_____
B	3	1 Prop(t)	[2]	>MS_CARRIES[2]	_____
			[1]	>MS_CARRIES[1]	_____
			[0]	>MS_CARRIES[0]	_____
OUT	3	1 Prop(t)	[2]	>s6	_____
			[1]	>s5	_____
			[0]	>s4	_____
CIN	1	1 Prop(t)	[0]	>FALSE	_____
COU2	1	1 Prop(t)	[0]	>s7	_____
FEED	3	1 Feedthru	[2]	>FALSE	_____
			[1]	>FALSE	_____
			[0]	>FALSE	_____

```

-----
INSERT  MESSAGES  GRAPHICS  FORM          OVERLAY  RECORD  UTILITY
-----
BACK                                COMPRESS
-----

```

```

:DEFINITION DEFINED

```

Figure A.38

```

*****
Random_Logic: <gensettle/settle/tutorial_mod/dff_Bbit Random Logic Block Editor
-----Genesis Version v7.0-----
RANDOM LOGIC Functional Specification

```

```

DEL EDIT MOVE 0 >DFFO_____ (DFF)

```

INSERT	MESSAGES	GRAPHICS	FORM	OVERLAY	RECORD	UTILITY
ACCEPT_FORM	CHECK_FORM	NEW	DELETED_GROUP	VIEW		
PIGEONHOLE	SAVE	SIGNALS	EDIT_GROUP	TEXT_SPEC		
CANCEL	TECH_CHECK	UNUSED				

```

: DEFINITION: DEFINE:

```

Figure A.39

```

*****
Random_Logic <gensettle/settle/tutorial_mod/dff_Bbit Random Logic Block Editor
-----Genesil Version v7.0-----
Random Logic Block Specification

```

```

Block type DFF
Block index 0
Name >DFFC_____
Width >_B

```

		Regime		
Connector	Width	:	Timing	
PHX	1	:	1 Phase X	>phase_a_____
PHY	1	:	1 Phase Y	>phase_b_____
IN	E	:	1 Vy(t-1)	>s7, s6, s5, s4, LS_OUT[3 0]_____
OUT	E	:	1 Sy(t)	>P7, P6, P5, P4, P3, P2, P1, P0_____
LOAD	1	:	1 Vy(t-1)	>TRUE_____

```

-----
INSERT MESSAGES GRAPHICS FORM OVERLAY RECORD UTILITY
-----
BACK CONVERT EXPAND
-----

```

```
>DEFINITION:DEFINE:
```

Figure A.40

```

*****
MULTIPLIER <gensettle/settle/tutorial_mod/library_mult MULTIPLIER Block Editor
-----Genesis Version v7.0-----
MULTIPLIER SPECIFICATION

```

```

MC Width      >4 _____
MP Width      >4 _____
Input Latch   NO YES
Output Latch: NO YES

```

Width Timing

```

Multiplier
MP_IN          <4> 1 pr      >a[3:0] _____
Multiplicand
MC_IN          <4> 1 pr      >b[3:0] _____
LSP
LS_OUT         <4> 0 pr      >LS_OUT[3:0] _____
STICKY         <2> 0 pr      >STICKY _____
ZERO          Scalar 0 pr      >ZERO _____

MEI
ME_SUM         <3> 0 pr      >ME_SUM[2:0] _____
ME_CARRIES    <3> 0 pr      >ME_CARRIES[2:0] _____

```

```

-----
INSERT  MESSAGE  GRAPHICS  FORM          OVERLAY  RECORD  UTILITY
-----
ACCEPT_FORM  CHECK_FORM  TEXT_SPEC          VIEW
FIGEDHOLE   SAVE
CANCEL
-----

```

```

Enter Command
:DEFINITION:DEFINED:

```

Figure A.41

```

*****
Module ^gensettle/settle/tutorial_mod                                     Definition
-----Genesisil Version v7.0-----
Object Name >adder_3bit_____ FIRST PREV NEXT LAST
Display NONE CHECK_RESULTS LENGTH SIG_TYPE PRIORITY
Sort by NET_NAME CONNECTOR_NAME ATTRIBUTE INTERNAL_EXTERNAL
-----
DEFAULT/USER/BOTH Name      Net Name      I-E Attribute
MS_CARRIES[2:0]             >MS_CARRIES[2:0]_____ I E NA      EDIT
MS_SUM[2:0]                 >MS_SUM[2:0]_____ I E NA      EDIT
s4                           >s4_____ I E NA      EDIT
s5                           >s5_____ I E NA      EDIT
s6                           >s6_____ I E NA      EDIT
s7                           >s7_____ I E NA      EDIT

```

```

-----
INSERT  MESSAGES GRAPHICS FORM          OVERLAY  RECORD  UTILITY
-----
ACCEPT_FORM  CHECK_SPEC  NET_NETLIST  SPECIFICATION  WRITE_SPEC
PIGEONHOLE  VIEW_DRC_NETLIST          READ_SPEC
CANCEL                                           SAVE
-----

```

```

Enter [string]
>DEFINITION:OBJECT_NETLIST:

```

Figure A.42

```

*****
Module: ^gensettle/settle/tutorial_mod                                     Definition
-----Genesisl Version v7.0-----
Object Name >diff_Bbit_____ FIRST PREV NEXT LAST
Display NONE CHECK_RESULTS LENGTH SIG_TYPE PRIORITY
Sort by NET_NAME CONNECTOR_NAME ATTRIBUTE INTERNAL_EXTERNAL
-----
DEFAULT/USER/BOTH Name      Net Name      I-E Attribute
LS_OUT[3 0]                >LS_OUT[3.0]_____ I E NA          EDIT
P0                          >P0_____          I E NO_READ     EDIT
P1                          >P1_____          I E NO_READ     EDIT
P2                          >P2_____          I E NO_READ     EDIT
P3                          >P3_____          I E NO_READ     EDIT
P4                          >P4_____          I E NO_READ     EDIT
P5                          >P5_____          I E NO_READ     EDIT
P6                          >P6_____          I E NO_READ     EDIT
P7                          >P7_____          I E NO_READ     EDIT
phase_a                    >phase_a_____    I E NO_DRIVER   EDIT
phase_b                    >phase_b_____    I E NO_DRIVER   EDIT
s4                          >s4_____          I E NA          EDIT
s5                          >s5_____          I E NA          EDIT
s6                          >s6_____          I E NA          EDIT
s7                          >s7_____          I E NA          EDIT

```

```

-----
INSERT MESSAGES GRAPHICS FORM OVERLAY RECORD UTILITY
-----
ACCEPT_FORM CHECK_SPEC NET_NETLIST SPECIFICATION WRITE_SPEC
PIGEDINHOLE VIEW_DRC_NETLIST READ_SPEC
CANCEL SAVE
-----

```

```

F-ter [string]
DEFINITION:OBJECT_NETLIST>

```

Figure A.43

e. Select Object Name, and type in library_mult (Figure A.44). Do the same as in c above.

f. Now select SPECIFICATION (Figure A.44) to check the netlist. The system will state if valid or advise of errors which are listed by using VIEW_DRC_NETLIST.

3. The module must now be floorplanned. Simulation and timing analysis cannot be performed on a module prior to netlisting and floorplanning.

a. After netlist validation, the screen should show a module Definition menu. If not, go BACK or ACCEPT_FORM to return to the Definition menu. Select FLOOR_PLAN.

b. Figure A.45 should now be on the screen. Select PLACEMENT (Figure A.45).

c. Next select each unplaced block (Figure A.46) until all are placed. Blocks may be moved by hooking the object with the MOUSE. The rest of the commands are explained in detail in Chapter 6 of the System Description Applications Commands manual.

d. Next go BACK (Figure A.46) to Figure A.45.

e. Select PINOUT (Figure A.45).

f. Now select AUTO_PINOUT (Figure A.47).

g. Go BACK (Figure A.47) to Figure A.45.

h. Select FUSION (Figure A.45).

i. Select AUTO_FUSE (Figure A.48).

j. Now go BACK (Figure A.48) to A.45.

```

*****
Module: ^gensettle/settle/tutorial_mod                                     Definition
-----Genesisil Version v7 0-----
Object Name: >library_mult_____ FIRST PREV NEXT LAST
Display NONE CHECK_RESULTS LENGTH SIG_TYPE PRIORITY
Sort by NET_NAME CONNECTOR_NAME ATTRIBUTE INTERNAL_EXTERNAL
-----
DEFAULT/USER/BOTH Name      Net Name      I-E Attribute      EDIT
LS_OUT[3:0]                >LS_OUT[3:0]_____ I E NA              EDIT
MC_IN[3:0]                 >b[3:0]_____      I E NO_DRIVER      EDIT
MP_IN[3:0]                 >a[3:0]_____      I E NO_DRIVER      EDIT
MS_CARRIES[2:0]           >MS_CARRIES[2:0]_____ I E NA              EDIT
MS_SUM[2:0]               >MS_SUM[2:0]_____  I E NA              EDIT
STICKY[1:0]               >STICKY[1:0]_____  I E NO_READ        EDIT
ZERO                      >ZERO_____         I E NO_READ        EDIT

```

```

-----
INSERT MESSAGES GRAPHICS FORM          OVERLAY          RECORD          UTILITY
-----
ACCEPT_FORM      CHECK_SPEC      NET_NETLIST      SPECIFICATION    WRITE_SPEC
PIGEDNHDLE      VIEW_DRC_NETLIST          READ_SPEC
CANCEL          SAVE
-----

```

```

Enter {string}
>DEFINITION:OBJECT_NETLIST:

```

Figure A.44

```

.....
Module: ^gensettle/settle/tutorial_mod Floorplan
-----Genesisil Version v7.0-----
CANCEL
CONFIRM
JACK
$ _NULL. $ _L1 1. DEFINE "DEFINE"
SPECIFICATION
) Specification is read
BLOCK $ _L1 0. EDIT
EXPAND
BACK
CANCEL
CONFIRM
BACK
$ _NULL. $ _L1 2. DEFINE "DEFINE"
SPECIFICATION
CANCEL
CONFIRM
BACK
OBJECT_NETLIST
) netlist version 1 0
NEXT_NAME NEXT
) dff_Bois
NEXT_NAME NEXT
) library_mult
CANCEL
CONFIRM
DEFINITION
FLOORPLAN
  Checking file currency
) Internal Object Hierarchy Initialized
) Completing Data Gathering Phase
) All input files are up to date
) ##idx=2 ftotalplblk=3
) ##chnlidx=2
) Read spec is done
) ##logd=0
-----
INSERT  MESSAGES  GRAPHICS                OVERLAY  RECORD  UTILITY
-----
DONE          PLACEMENT
CANCEL        FINOUT
              FUSION
-----

Command
>DEFINITION>FLOORPLAN:

```

Figure A.45

```

.....
Module ^gensettle/settle/tutorial_mod                               Floorplan
-----Genesisil Version v7.0-----
Degree of Freedom : MOVE( ON/OFF ) ROTATE( ON/OFF ) | Unplaced_block
                                                    |adder_3bit
DISPLAY VECTOR( ON/OFF ) : MODE Edge_Density( ON/OFF |eff_8bit
                                                    |library_mult

```

```

-----
:INSERT MESSAGES GRAPHICS OVERLAY RECORD UTILITY
-----
BACK BEST_PLACE CENTER FIT
PLACE_PLACE LIST_BEST PAN IDENTIFY
TEXT_SPEC CHECK_SPEC SCALE
AUTO_PLACEMENT ZOOM
-----

```

```

Enter block to PLACE[str]
:DEFINITION: FLOORPLAN:

```

Figure A.46

```

.....
Module  ^gensettle/settle/tutorial_mod                               Floorplan
-----Genesis1 Version v7 0-----

```

```

Mode  ADD_CONNECTOR MOVE_CONNECTOR REMOVE_CONNECTOR
Edge  NORTH SOUTH EAST WEST

```

```

NORTH_CONNECTOR EAST_CONNECTOR SOUTH_CONNECTOR WEST_CONNECTOR
: _____ STICKY[0] _____ LS_OUT[0] _____ a[2] _____
STICKY[1] _____ LS_OUT[1] _____ a[3] _____
ZERO _____ LS_OUT[2] _____ b[2] _____
: _____ LS_OUT[3] _____ b[3] _____
MS_CARRIES[0] _____
MS_CARRIES[1] _____
MS_CARRIES[2] _____
MS_SUM[0] _____
MS_SUM[1] _____
MS_SUM[2] _____
P0 _____
P1 _____
P2 _____
P3 _____
P4 _____
P5 _____
P6 _____
P7 _____
a[0] _____
a[1] _____
b[0] _____
b[1] _____
phase_a _____
phase_b _____
s4 _____
s5 _____
s6 _____
s7 _____
: _____

```

```

-----
INSERT  MESSAGES  GRAPHICS  FORM          OVERLAY          RECORD          UTILITY
-----
BACK    SET_MODE    AUTO_PINOUT    CHECK_SPEC
RESET_PINOUT  SET_EDGE
TEXT_SPEC
-----

```

```

Enter connector name: [tr]
:DEFINITION.FLOORPLAN

```

Figure A.47

```

*****
Module  ^gensettle/settle/tutorial_mod          Floorplan
-----Genesis Version v7.0-----

```

INSERT	MESSAGES	GRAPHICS	FORM	OVERLAY	RECORD	UTILITY
BACK				ANTD_FUSE		FIT
RESET_FUSION				FUSE		CHECK_SPEC
TEXT_SPEC				DO_NOT_FUSE		
				NEXT_FUSE		
				CENTER		
				PAN		
				SCALE		
				ZOOM		

```

Enter ^cursor to FUSE(pnt)
:DEFINITION: FLOORPLAN:

```

Figure A.48

k. Select DONE (Figure A.45), followed by CONFIRM.
 If all goes well, the floorplan will be complete.

4. Now simulation and timing analysis can be performed as described in the previous sections.

E. TUTOR_CHIP CHIP

This section is a tutorial for a top-down chip design of a chip named tutor_chip. The chip consists of tutorblk_1 and tutorblk_2, a clock, input/out pads, a VSS pad, and VDD pad. A schematic with signal names is shown in Figure A.49.

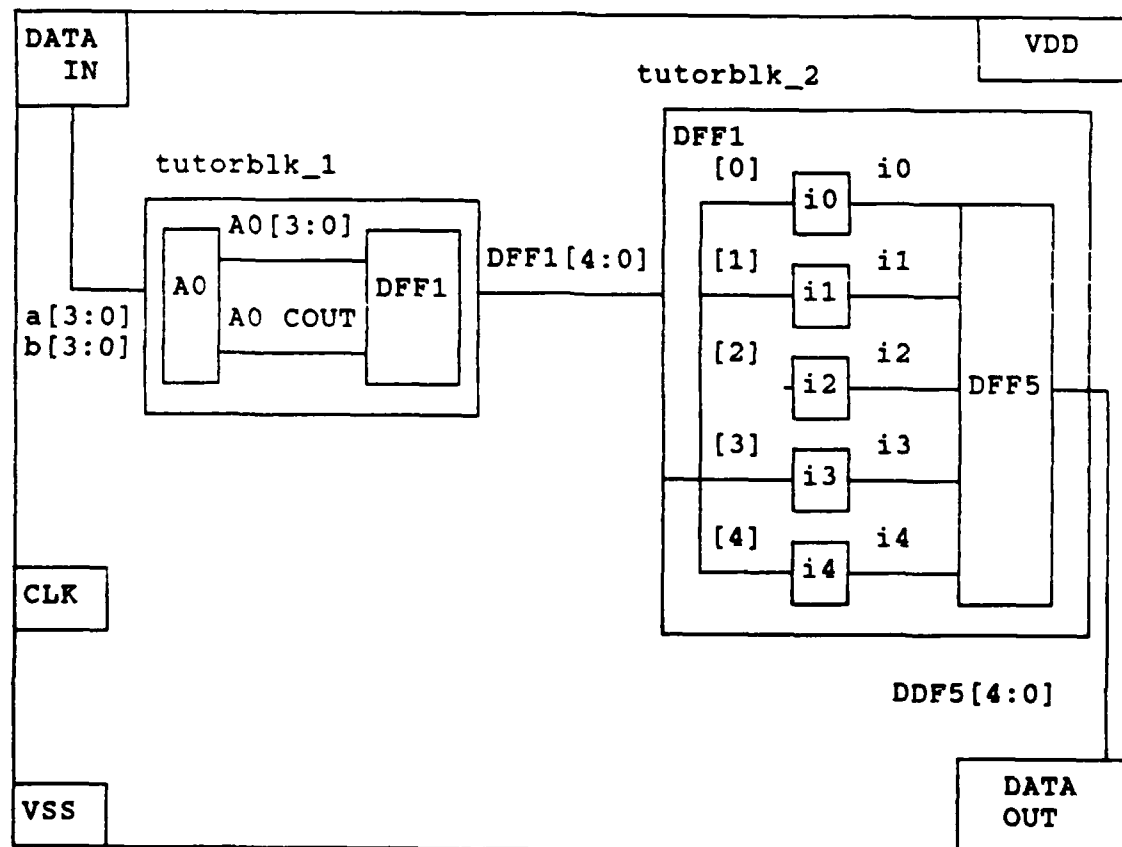

Figure A.49 Tutor_Chip Chip

1. Definition and Specification:
 - a. Proceed as in the previous sections down through ATTACH NEW. Now select CHIP from the Executive menu (Figure A.50).
 - b. Name the chip tutor_chip when prompted, and attach it to the tree.
 - c. Select DEFINITION and HEADER. On the Chip Header form (Figure A.51) select Fab line VTC_CP10A and leave the Package Type as NO_PACKAGE.
 - d. Select ACCEPT_FORM (Figure A.51).
 - e. Now select SPECIFICATION from the Definition menu and the screen should show a blank Chip Specification form (Figure A.52).
 - f. Next select ATTACH_NEW (Figure A.52) and BLOCK (Figure A.53). Name the object data_in when prompted.
 - g. Just like the module, each sub-object on the chip must be defined by using the appropriate Header and Specification forms.
 - h. Select DEFINE next to data_in on the Chip Specification menu.
 - i. Select HEADER from the next screen. Select PAD from the Header form for Function type (Figure A.54) and CONFIRM. Select ACCEPT_FORM.
 - j. Next select SPECIFICATION and the screen should show a PAD Functional Specification menu (Figure A.55).

```

*****
User: ^gensettle/settle                               Executive
-----Genesis Version v7.0-----

```

```

) START Genesis job ^gensettle/settle/tutorchip on micro1
) Mon Aug 22 22 02.41 1988
)
)           Genesis (tm) System Version v7.0
)
)           Copyright Silicon Compiler Systems Corporation 1988
)
)           License Material -- Program Property of SCS -- All Rights Reserved
)
) This software is protected as an unpublished work and the copyright notice
) does not imply publication. This software contains confidential trade
) secrets of Silicon Compiler Systems Corporation. The reproduction,
) transfer or use of this software or the supporting documentation is
) governed by a license agreement with SCS, and the software shall be used
) solely in accordance with such agreement.
)
)           RESTRICTED RIGHTS LEGEND
)
)           Use, duplication or disclosure by the Government
)           is subject to restrictions as set forth in
)           subparagraph (c)(1)(ii) of the Rights in
)           Technical Data and Computer Software clause
)           at 252 227-7013
)
)
) CONTINUE
) SELECT_OBJECT
) ATTACH
) NEW

```

```

-----
INSERT  MESSAGES  GRAPHICS                OVERLAY          RECORD          UTILITY
-----
CANCEL          BLOCK                GENERAL_MODULE  CHIP              CHIP_SET
                                     PARALLEL_DF
                                     RANDOM_LOGIC
-----

```

```

ATTACH New Object Type
:SELECT_OBJECT>ATTACH>NEW:

```

Figure A.50

```

*****
Chip ^gensettle/settle/tutor_chip                                     Definition
-----Genesis1 version v7.0-----
Object Type CHIP
-----
Technology
Fab line
      AMI_CT20A          GEN_CN20A          GEN_CN30A
      GEN_CP12A         GES_CP12A         IMP_CP20A
      NCR_CN20A         NSC_CN12A         NSC_CN20A
      DRB_CN20A         RIC_CN20A         SSC_CN20A
      US2_CN20A         VTC_CN16A         VTC_CP10B
      VTC_CP12A         VTI_CN20A
Package Type
      CLLCC100f         CLLCC124g         CLLCC132e
      CLLCC132g         CLLCC68d         CLLCC68dB
      CLLCC68dC         CLLCC84d         CLLCC84dB
      CLLCC84dC         CPGA100e         CPGA108e
      CPGA120e         CPGA132c         CPGA144f
      CPGA149f         CPGA180f         CPGA180g
      CPGA224f1        CPGA224f2         CPGA68c
      CPGA84c          CPGA84c          CPGA84e
      CSB2E:           CSB40c           CSB40d
      CSB43d           CSB64c           INT_PkG
      PDIP40c          PDIP48c          PDIP64c
      PLDCC44c         PLDCC68e         PLDCC84e
      PPG-100e         PPGA120e         PPGA149f
      NO_PACKAGE
-----
Created By gensettle                               Date Mon Aug 22 22 04 33 1988
Last Modified                               Date Mon Aug 22 22 04 33 1988
Status
Placed                                     No          Routed                                     No
-----
Compile parameters
COMPILER TYPE                               STANDARD    Estimate (OFF, POWER, CLOCK, BUS, ALL)
-----
Notes
-----
INSERT MESSAGES GRAPHICS FORM              OVERLAY    RECORD    UTILITY
ACCEPT FORM
CANCEL
-----

```

DEFINITION: HEADER:

Figure A.51

```

*****
Chip: ^gensettle/settle/tutor_chip                                     Definition
-----Genesisil Version v7.0-----
Sub-Objects Name Type
-----
ATTACH_NEW                               ATTACH_EXISTING
-----

```

```

-----
INSEPT  MESSAGES  GRAPHICS  FORM          OVERLAY  RECORD  UTILITY
-----
ACCEPT_FORM  HEADER          ATTACH          NET_NETLIST
                                     OBJECT_NETLIST
-----

```

:DEFINITION

Figure A.52

```

*****
Chip: ^gensettle/settle/tutor_chip                                     Definition
-----Genesisil Version v7.0-----
Sub-Objects Name  Type
-----
ATTACH_NEW              ATTACH_EXISTING
-----

```

```

-----
INSERT  MESSAGES  GRAPHICS  FORM              OVERLAY  RECORD  UTILITY
-----
CANCEL          BLOCK          GENERAL_MODULE
                PARALLEL_PATH
                RANDOM_LOGIC
-----

```

```

New Object Type
:DEFINITION: ATTACH: ATTACH_NEW:

```

Figure A.53

```

*****
General_Block: ^gensettle/settle/tutor_chip/data_in                               Definition
-----Genesisil Version v7.0-----
Object Type: BLOCK
Function type
      External          FCX_BLOCK          FIFO
      Label            LPLA              LRAM
      LROM             MULTIPLIER        PAD
      Parallel_Datpath PLA              RAM
      Random_Logic     ROM
-----
Technology CMOS-1
Fab line VTC_CP10B
-----
Created By gensettle                               Date: Mon Aug 22 22 06 26 1988
Last Modified                               Date: Mon Aug 22 22 06 35 1988
Status
-----
Compile parameters
COMPILER TYPE          STANDARD          NONE          ESTIMATE
Power Adjuster  : 1.00_ (multiplier)
-----
Notes
:-----
:-----
:-----

```

```

-----
INSERT  MESSAGEE  GRAPHICS  FORM          OVERLAY  RECORD  UTILITY
-----
ACCEPT FORM
CANCEL
-----

```

```

:DEFINITION:DEFINED:HEADER:

```

Figure A.54

```
*****
PAD  ^gensettle/settle/tutor_chip/data_in                               Pad Block Editor
-----Genesisil Version v7.0-----
```

PAD Functional Specification.

```
Pad Type          DATA      VSS      VDD      CLOCK
                  TEST       STROBE   CLKPRCIN ANALOG
-----
Data Flow         IN         OUT      IO
Protection        FAB_DEFAULT N_PROTECTION NP_PROTECTION
Input Processing  SIMPLE    PARITY   SHIFT    SYNCHRONIZER
Input Driver      NO_CLOCK  DIRECT   TRISTATE PRECHARGED
Inverting Driver  YES       NO
Change pitch     YES       NO
Width            >_B
```

```
-----
Data              >DATA_____ Bonding Pads:
                  (DATA)
```

```
-----
Phase B          >phase_b_____ Connectors:
Data In         >a[3 0].b[3 0]_____ (PHASE_B)
                  (DIN)
```

```
-----
INSERT  MESSAGES  GRAPHICS  FORM          OVERLAY      RECORD      UTILITY
ACCEPT_FORM  CHECK_FORM          VIEW
PIGEONHOLE  SAVE                TEXT_SPEC
CANCEL      TECH_CHECK
```

DEFINITION: DEFINED

Figure A.55

Select IN for Data Flow. All other specifications are defaults except width, Phase B, and Data In. Fill these to match Figure A.55.

k. Now select ACCEPT_FORM (Figure A.55). Go BACK to the Chip Specification form (Figure A.56). Figure A.56 is a complete Chip Specification form for tutor_chip. Your Chip Specification form should have only a data-in PAD on it at this time.

l. For each of the remaining PADS (clock, vss, vdd, and data_out), using steps f through j except for the following PAD Functional Specification form changes:

(1) Clock PAD: Select CLOCK for Pad type. All other specifications are defaults except PHASE_A and PHASE_B type in phase_a, and phase_b in accordance with Figure A.57. ACCEPT_FORM (Figure A.57) and continue to the next PAD.

(2) VSS PAD: Select VSS for Pad Type. All other inputs are left to defaults. ACCEPT_FORM (Figure A.58) and continue to the next PAD. The Chip Specification form should now look like Figure A.59. The order is not important.

(3) Vdd PAD: Select vdd for PAD type. All other inputs are left to defaults. ACCEPT_FORM (Figure A.60) and continue to the next PAD.

(4) data_out PAD: Select OUT for Data Flow. All other specifications are defaults except width, Phase A, Phase B, and Data Out. Fill these in to match Figure A.61. ACCEPT_FORM and go BACK to the Chip Specification form.

```

*****
Chip: ^gensettle/settle/tutor_chip                                     Definition
-----Genesisil Version v7.0-----
Sub-Objects Name  Type
>data_in_____  PAD_____                DEFINE DETACH
>clock_____    PAD_____                DEFINE DETACH
>vss_____      PAD_____                DEFINE DETACH
>tutorblk_1_____ Random_Logic_____        DEFINE DETACH
>tutorblk_2_____ Random_Logic_____        DEFINE DETACH
>vdd_____      PAD_____                DEFINE DETACH
>data_out_____  PAD_____                DEFINE DETACH
-----
ATTACH_NEW                ATTACH_EXISTING
-----

```

```

-----
INSERT  MESSAGES  GRAPHICS  FORM          OVERLAY          RECORD          UTILIT
-----
ACCEPT_FORM  HEADER          ATTACH          NET_NETLIST
                OBJECT_NETLIST
-----

```

DEFINITION:

Figure A.56

 PAD: ~gensettle/settle/tutor_chip/clock Pad Block Editor

-----GenesisII Version v7.0-----

PAD Functional Specification:

Pad Type	DATA TEST	VBS STROBE	VDD CLKPRDCIN	CLOCK ANALOG
Protection	FAB_DEFAULT	N_PROTECTION	NP_PROTECTION	
Layout	PAD_LIMITED		NDN_PAD_LIMITED	
Clk Input	SINGLE	DOUBLE		
Clkpower	RING	POWERPAD	LOCAL_ISOLATED	
Divider	DIVIDE_2	NO_DIVIDE	CLKPROC	
Loading	150PF	100PF		

Bonding Pads:				
Clock	>DATA_____		(DATA)	
Vss	>VSS_____		(VSS)	
Vdd	>VDD_____		(VDD)	

Connectors				
Phase A	>phase_a_____		(PHASE_A)	
Phase B	>phase_b_____		(PHASE_B)	

INSEFT	MESSAGES	GRAPHICS	FORM	OVERLAY	RECORD	UTILITY
ACCEPT_FORM		CHECK_FORM				VIEW
FIGEONHOLE		SAVE				TEXT_SPEC
CANCEL		TECH_CHECK				

>DEFINITION>DEFINE>

Figure A.57

 PAD ^gensettle/settle/tutor_chip/vss Pad Block Editor

-----Genesis Version v7.0-----

PAD Functional Specification:

Pad Type	DATA TEST	VSS STROBE	VDD CLKPROCIN	CLOCK ANALOG
Style	CORE	RING	COMBINED	CLKPOWER_ISOLATED
Bonding	SINGLE	DOUBLE		
Inductance	DEFAULT	CHANGE		
Change pitch	YES	NO		
Width	>_0			

Bonding Pads:

Vss >VSS _____ (VSS)

Connectors

INSERT	MESSAGES	GRAPHICS	FORM	OVERLAY	RECORD	UTILITY
ACCEPT_FORM	CHECK_FORM				VIEW	
PIGEONHOLE	SAVE				TEXT_SPEC	
CANCEL	TECH_CHECK					

DEFINITION:DEFINED

Figure A.58

```

*****
Chip: ^gensettle/settle/tutor_chip                                     Definition
-----Genesil Version v7.0-----
Sub-Objects Name  Type
data_in          PAD
clock            PAD
vss              PAD
ATTACH_NEW      ATTACH_EXISTING

```

```

-----
INSERT  MESSAGES  GRAPHICS  FORM          OVERLAY          RECORD          UTILIT
-----
CANCEL                                DEFAULT_TO_CURRENT_NAME

```

```

-----
Enter New Name of Created Object [path]
>DEFINITION:ATTACH:ATTACH_EXISTING:^gensettle/settle/tutorblk_1>

```

Figure A.59

.....
 PAD: ^gensettle/settle/tutor_chip/vdd Pad Block Editor

-----Genesis Version v7.0-----

PAD Functional Specification

Pad Type	DATA TEST	VSS STROBE	VDD CLKPROCIN	CLOCK ANALOG
Style	CORE	RING	COMBINED	CLKPOWER_ISOLATED
Bonding	SINGLE	DOUBLE		
Inductance	DEFAULT	CHANGE		
Change pitch	YES	NO		
Width	>_0			

 Vdd >VDD _____ Bonding Pads (VDD)

 Connectors

INSERT	MESSAGES	GRAPHICS	FORM	OVERLAY	RECORD	UTILITY
ACCEPT_FORM		CHECK_FORM			VIEW	
FIGEOWHOLE		SAVE			TEXT_SPEC	
CANCEL		TECH_CHECK				

DEFINITION:DEFINE

Figure A.60

 PAD: ^gensettle/settle/tutor_chip/data_out Pad Block Editor
 -----Genesis1 Version v7.0-----

PAD Functional Specification:

Pad Type	DATA TEST	VSS STROBE	VDD CLKPRCIN	CLOCK ANALOG
Data Flow	IN	OUT	ID	
Output Latch	STATIC	CLOCKED	TRANSPARENT	
Drive Speed	DRVSPEED3	DRVSPEED2	DRVSPEED1	DRVSPEED0 (slowest)
Inverting Driver	YES	NO		
Drive Type	FABLINE	TTL	CMOS	
Change pitch	YES	NO		
Width	2_5			

Bonding Pads

Data >DATA_____ (DATA)

Connectors

Phase A >phase_a_____ (PHASE_A)
 Phase B >phase_b_____ (PHASE_B)
 Data Out >diff5[4 0]_____ (DDUT)
 Disable >DISABLE_____ (DISABLE)

INSERT	MESSAGES	GRAPHICS	FORM	OVERLAY	RECORD	UTILITY
ACCEPT_FORM	CHECK_FORM				VILW	
PIGEONHOLE	SAVE				TEXT_SPEC	
CANCEL	TECH_CHECK					

! DEFINITION: DEFINE!

Figure A.61

m. From the Chip Specification form, select ATTACH_EXISTING. The user will now be prompted for the path to the existing object. Type in "gensettle/settle/tutorblk_1 and depress RETURN (use your own name and path unless you are in Settle's account). Now select DEFAULT_TO_CURRENT_NAME. The Chip Specification form should now include tutorblk_1.

n. Attach tutorblk_2 in the same manner. The Chip Specification form should now contain the same objects as Figure A.56.

2. The Chip must now be netlisted:

a. Select OBJECT_NETLIST (Figure A.56) and select each object's netlist, as described in the module section and ensure all object netlists match Figure A.62 - A.67. Type in the required signal names where applicable, and depress RETURN at the end of each line.

b. Select SPECIFICATION (Figure A.67), and if there are no netlist errors, the Chip Specification form should be on the screen (Figure A.56). Now select ACCEPT_FORM (Figure A.56), and the screen will now show the Definition menu as illustrated in Figure A.68.

3. The Chip must now be floorplanned:

a. Select FLOORPLAN (Figure A.68).
b. Use the module placement procedures to place the two unplaced blocks (Figure A.69).

c. Go BACK to the initial floorplan menu (Figure A.70). Select PINOUT. All unplaced PADS are now listed.

```

*****
Chip: ^gensettle/settle/tutor_chip                                     Definition
-----Genesisil Version v7.0-----
Object Name >data_in_____ FIRST PREV NEXT LAST
Display NONE CHECK_RESULTS LENGTH SIG_TYPE PRIORITY
Sort by NET_NAME CONNECTOR_NAME ATTRIBUTE INTERNAL_EXTERNAL
-----
DEFAULT/USER/BOTH Name      Net Name      I-E Attribute
DATA[7:0]                   >DATAIN_PADS[7:0]_____ I E NA      EDIT
DIN[7:0]                     >a[3:0].b[3:0]_____ I E NA      EDIT
PHASE_B                      >phase_b_____ I E NA      EDIT

```

```

-----
INSERT  MESSAGES  GRAPHICS  FORM          OVERLAY          RECORD          UTILITY
ACCEPT_FORM  CHECK_SPEC  NET_NETLIST  SPECIFICATION  WRITE_SPEC
PIPEDHOLE   VIEW_DRC_NETLIST          READ_SPEC
CANCEL                                           SAVE
-----

```

```

Enter: {string}
:DEFINITION: OBJECT_NETLIST:

```

Figure A.62

```

*****
Chip ^gensettle/settle/tutor_chip                                     Definition
-----Genesis1 Version v7.0-----
Object Name >vss _____ FIRST PREV NEXT LAST
Display NONE CHECK_RESULTS LENGTH SIG_TYPE PRIORITY
Sort by NET_NAME CONNECTOR_NAME ATTRIBUTE INTERNAL_EXTERNAL
-----
DEFAULT/USER/BOTH Name Net Name I-E Attribute

```

```

-----
INSERT MESSAGES GRAPHICS FORM OVERLAY RECORD UTILITY
-----
ACCEPT_FORM CHECK_SPEC NET_NETLIST SPECIFICATION WRITE_SPEC
FINGERHOLE VIEW_DRC_NETLIST READ_SPEC
CANCEL SAVE
-----

```

```

Enter (string)
:DEFINITION:OBJECT_NETLIST:

```

Figure A.63

```

*****
Chip ^gensettle/settle/tutor_chip                                     Definition
-----Genesisil Version v7.0-----
Object Name >tutorblk_1_____ FIRST PREV NEXT LAST
Display NONE CHECK_RESULTS LENGTH SIG_TYPE PRIORITY
Sort by NET_NAME CONNECTOR_NAME ATTRIBUTE INTERNAL_EXTERNAL
-----
DEFAULT/USER/BOTH Name      Net Name      I-E Attribute
a[3 0]                      >a[3 0]_____ I E NA      EDIT
b[3 0]                      >b[3 0]_____ I E NA      EDIT
dff1[4 0]                  >dff1[4 0]____ I E NA      EDIT
phase_a                    >phase_a_____ I E NA      EDIT
phase_b                    >phase_b_____ I E NA      EDIT

```

```

-----
INSERT  MESSAGE  GRAPHICS  FORM          OVERLAY          RECORD          UTILITY
-----
ACCEPT_FORM  CHECK_SPEC  NET_NETLIST  SPECIFICATION  WRITE_SPEC
PIGEONHOLE  VIEW_DRC_NETLIST  REAL_SPEC
CANCEL                                             SAVE
-----

```

```

Enter [string]
>DEFINITION,OBJECT_NETLIST>

```

Figure A.64

```

*****
Chip: ~gensettle/settle/tutor_chip                               Definition
-----Genesisil Version v7.0-----
Object Name >tutorblk_2_____ FIRST PREV NEXT LAST
Display NONE CHECK_RESULTS LENGTH BIO_TYPE PRIORITY
Sort by NET_NAME CONNECTOR_NAME ATTRIBUTE INTERNAL_EXTERNAL
-----
DEFAULT/USER/BOTH Name      Net Name      I-E Attribute
dff1[4 0]                  >dff1[4:0]_____ I E NA      EDIT
dff5[4 0]                  >dff5[4:0]_____ I E NA      EDIT
phase_a                    >phase_a_____ I E NA      EDIT
phase_b                    >phase_b_____ I E NA      EDIT

```

```

-----
INSERT MESSAGES GRAPHICS FORM OVERLAY RECORD UTILITY
-----
ACCEPT_FORM CHECK_SPEC NET_NETLIST SPECIFICATION WRITE_SPEC
FIGUREHOLE VIEW_DRC_NETLIST READ_SPEC
CANCEL SAVE
-----

```

```

Enter [string]
:DEFINITION:OBJECT_NETLIST>

```

Figure A.65

```

*****
Chip  ^gensettle/settle/tutor_chip                                     Definition
-----Genesisil Version v7.0-----
Object Name  >vdd                                     FIRST  PREV          NEXT  LAST
Display  NONE  CHECK_RESULTS  LENGTH  SIG_TYPE  PRIORITY
Sort by  NET_NAME  CONNECTOR_NAME  ATTRIBUTE  INTERNAL_EXTERNAL
-----
DEFAULT/USER/BOTH Name      Net Name          I-E Attribute

```

```

-----
INSERT  MESSAGES  GRAPHICS  FORM          OVERLAY          RECORD          UTILITY
-----
ACCEPT_FORM      CHECK_SPEC      NET_NETLIST      SPECIFICATION    WRITE_SPEC
PIGEONHOLE      VIEW_DRC_NET_LIST
CANCEL
-----

```

```

Enter (setting):
: DEFINITION: OBJECT_NETLIST >

```

Figure A.66

```

*****
Chip "gensettle/settle/tutor_chip" Definition
-----Genesisil Version v7 0-----
Object Name >data_out_____ FIRST PREV NEXT LAST
Display NONE CHECK_RESULTS LENGTH SIG_TYPE PRIORITY
Sort by NET_NAME CONNECTOR_NAME ATTRIBUTE INTERNAL_EXTERNAL
-----
DEFAULT/USER/BOTH Name Net Name I-E Attribute
DATA[4 0] >DATAOUT[4:0]_____ I E NA EDIT
DISABLE >FALSE_____ I E NA EDIT
DOUT[4 0] >dff[4 0]_____ I E NA EDIT
PHASE_A >phase_a_____ I E NA EDIT
PHASE_B >phase_b_____ I E NA EDIT

```

```

-----
INSERT MESSAGES GRAPHICS FORM OVERLAY RECORD UTILITY
-----
ACCEPT_FORM CHECK_SPEC NET_NETLIST SPECIFICATION WRITE_SPEC
F1=ONHOLE VIEW_DRC_NETLIST READ_SPEC
CANCEL SAVE
-----

```

```

Enter {string}
:DEFINITION: OBJECT_NETLIST>

```

Figure A.67

```

*****
Chip: ^gensettle/settle/tutor_chip                                     Definition
-----Genesisil Version v7.0-----
) This object is producible in all current technologies
) Form is valid
) JACK
OBJECT_NETLIST
$ _NULL: OBJ_NAME ""
) data_in
$ _LI 0: NET_NAME "DATAIN_PADS[7:0]"
$ _NULL: OBJ_NAME "data_in"
) clock
$ _LI 0: NET_NAME "CLK_PAD"
$ _NULL: OBJ_NAME "clock"
) vss
$ _NULL: OBJ_NAME "vss"
) tutorblk_1
$ _NULL: OBJ_NAME "tutorblk_1"
) tutorblk_2
$ _NULL: OBJ_NAME "tutorblk_2"
) vdd
$ _NULL: OBJ_NAME "vdd"
) data_out
DATAOUT_PADS[4:0]
$ _NULL: OBJ_NAME ""
) data_out
$ _LI 0: NET_NAME "DATAOUT[4:0]"
$ _LI 1: NET_NAME "FALSE"
$ _NULL: $ _LI 2: NET_NAME "dff5[4:0]"
) CANCEL
) CHECK_SPEC
) LDR_CHECK
) No loop is detected
) netlist is valid
) SPECIFICATION
) Netlist is stored
) Key Parameters (set 120) Modified
) ACCEPT_FORM
-----
INSERT  MESSAGES  GRAPHICS  OVERLAY  RECORD  UTILITY
-----
BACK    HEADER      NET_NETLIST  FLOORPLAN  TEXT_SPEC_READ
        SPECIFICATION OBJECT_NETLIST CURRENCY_OFF TEXT_SPEC_WRITE
-----
) DEFINITION

```

Figure A.68

```

.....
Chip: ^gensettle/settle/totor_chip                               Floorplan
-----Genesis1 Version v7 0-----
Degree of Freedom : MOVE( ON/OFF ) ROTATE( ON/OFF )           Unplaced_block
                                                                tutorblk_1
DISPLAY VECTOR( ON/OFF )           : MODE Edge_Density( ON/OFF) tutorblk_2
-----

```

```

-----
INSERT  MESSAGES  GRAPHICS                                OVERLAY  RECORD  UTILITY
-----
BACK    BEST_PLACE                                     CENTER  FIT
RESET_PLACE  LIST_BEST                                  PAN      IDENTIFY
TEXT_EPEC   CHECK_SPEC
           AUTO_PLACEMENT
-----

```

```

Enter block to PLACE[str].
:DEFINITION>FLOORPLAN>

```

Figure A.69

.....
Chip ^gensettle/settle/tutor_chip Floorplan
-----Genesisil Version v7.0-----

INSERT MESSAGES GRAPHICS OVERLAY RECORD UTILITY

DONE PLACEMENT
CANCEL PINDOUT
FUSION

Command
>DEFINITION: FLOORPLAN:

Figure A.70

Select each PAD with the MOUSE. Place the cross hairs around the chip in the desired PAD location. Click the right MOUSE button. After placing a PAD, it may be moved by hooking it with the MOUSE, and moving it to the desired new location.

d. After placing all PADS, go BACK to the initial floorplan menu (Figure A.70) and select FUSION.

e. Select AUTO_FUSE. Go BACK to the initial floorplan menu (Figure A.70).

f. Select DONE (Figure A.70). If all pads are placed correctly, the system will confirm floorplan complete.

g. If there are PAD placement errors, try moving the PADS around and select DONE again.

4. After the chip is netlisted and floorplanned, it may be simulated and timing analysis performed in accordance with the previous block and module instructions.

5. The chip may be plotted using the following commands:

a. Select PLOT (Figure A.71).

b. Next select NEW_PLOT (Figure A.72).

c. Select LAYOUT for a VLSI layout of the chip (Figure A.73).

d. Now select WORKSTATION (Figure A.74), and then GO (Figure A.75).

e. If all things go well, the screen should show a layout similar to Figure A.76.

```

*****
Chip: ^gensettle/settle/tutor_chip                               Executive
-----Genesisil Version v7.0-----
)
) Capacitance for: 'phase_a' is 0.11 pf.
) Capacitance for: 'phase_b' is 0.12 pf.
) I: Peak AC current to VSS: 35763 uA
) Key Parameters: 250 transistors, Dissipation: 17.4 milliWatts@5V@10MHz
) Key Parameters (set 124) Modified
) Done with command COMPILE_LOAD_MODEL -----in Block: /data_out
) Times: real=40s, cpu=19s (u=12s, s=6 Bs) (c=19s)
) Executing command COMPILE_LAYOUT -----in Chip: /tutor_chip
)
) Fabline VTC_CP10B Technology: CMOS-1
) Package not found
) rcfreq02-U-1 Clock net phase_a given to have a maximum frequency of 10.00 Mhz
) z
) rcfreq02-U-1 Clock net phase_b given to have a maximum frequency of 10.00 Mhz
) z
) ROUTER maximum ir-drop voltages (mv) found VSS 24 VCC 35
) ROUTER maximum ir-drop voltages (mv) found VSS 24 VCC 35
) Package not found
) Chip size in um 2265 x 2221, in mils 89.2 x 87.4
) Key Parameters (set 121) Modified
) Key Parameters (set 123) Modified
) Done with command COMPILE_LAYOUT -----in Chip: /tutor_chip
) Times: real=186s, cpu=119s (u=97s, s=21s) (c=119s)
HP_PLOTTER
B_SIZE_PAPER
tutor
C
) PLOT STATISTICS 3034 vectors, 12651 rectangles, 5872 line rectangles, 14324
) skipped rectangles
PLOT_FILE
HP7580A
'tutor_1
) Plot is queued
BACK
-----
INSERT  MESSAGES  GRAPHICS                OVERLAY                RECORD                UTILITY
-----
EXIT_GENESIL  SELECT_OBJECT  DEFINITION              COMPILER               TOOLING
                PACKAGE_EDIT   SIMULATION             TIMING                 PLOT
                                                    TRANSLATE
-----

```

Figure A.71

```

*****
Chip "gensettle/settle/tutor_chip" Plot
-----GenesisII Version v7.0-----
) Capacitance for: 'phase_a' is 0.11 pf.
) Capacitance for: 'phase_b' is 0.12 pf.
) I: Peak AC current to VSS: 35763 uA
) Key Parameters: 250 transistors, Dissipation: 17.4 milliWatts@5V@10MHz.
) Key Parameters (set 124) Modified
) Done with command COMPILE:LOAD_MODEL -----in Block: /data_out
) Times real=40s; cpu=19s (u=12s, s=6.8s) (c=19s)
) Executing command COMPILE:LAYOUT -----in Chip: /tutor_chip
)
) Fabline VTC_CP10B Technology: CMOS-1
) Package not found.
) rcfreq02-U-1 Clock net phase_a given to have a maximum frequency of 10.00 Mhz
) z
) rcfreq02-U-1 Clock net phase_b given to have a maximum frequency of 10.00 Mhz
) z
) ROUTER maximum ir-drop voltages (mv) found VSS 24 VCC 35
) ROUTER maximum ir-drop voltages (mv) found VSS 24 VCC 35
) Package not found
) Chip size in um 2265 x 2221, in mils 89.2 x 87.4
) Key Parameters (set 121) Modified
) Key Parameters (set 123) Modified
) Done with command COMPILE:LAYOUT -----in Chip: /tutor_chip
) Times real=180s; cpu=119s (u=97s, s=21s) (c=119s)
HP PLOTTER
E_SIZE_PAPER
tutor
GO
PLOT STATISTICS 3034 vectors, 12651 rectangles, 5872 line rectangles, 14324
skipped rectangles
PLOT_FILE
HP7580A
tutor_1
Plot is queued
BACK
PLOT

```

```

-----
INSERT  MESSAGES  GRAPHICS  OVERLAY  RECORD  UTILITY
-----
BACK  NEW_PLOT
      PLOT_FILE
-----

```

:PLOT: Figure A.72

```

*****
Chip: "gensettle/settle/tutor_chip" Plot
-----Genesis Version v7.0-----
) Capacitance for: 'phase_b' is 0.12 pf.
) I: Peak AC current to VSS: 35763 uA
) Key Parameters 250 transistors, Dissipation: 17.4 milliWatts@5V@10Mhz.
) Key Parameters (set 124) Modified
) Done with command COMPILE:LOAD_MODEL -----in Block: /data_out
) Times: real=40s, cpu=19s (u=12s, s=6.8s) (c=19s)
) Executing command COMPILE:LAYOUT -----in Chip: /tutor_chip
)
) Fabline VTC_CP10B Technology: CMOS-1
) Package not found.
) rcfreq02-U-1 Clock net phase_a given to have a maximum frequency of 10.00 Mhz
) ?
) rcfreq02-U-1 Clock net phase_b given to have a maximum frequency of 10.00 Mhz
) ?
) ROUTER: maximum in-drop voltages (mv) found VSS 24 VCC 35
) ROUTER: maximum in-drop voltages (mv) found VSS 24 VCC 35
) Package not found.
) Chip size in um 2265 x 2221, in mils 89.2 x 87.4
) Key Parameters (set 121) Modified
) Key Parameters (set 123) Modified
) Done with command COMPILE:LAYOUT -----in Chip: /tutor_chip
) Times: real=180s, cpu=119s (u=97s, s=21s) (c=119s)
HP_PLOTTER
B_SIZE_PAPER
tutor
GD
) PLOT STATISTICS 3034 vectors, 12651 rectangles, 5872 line rectangles, 14324
skipped rectangles
PLOT_FILE
HF7580A
tutor_1
) Plot is queued
BACK
PLOT
NEW_PLOT
-----
INSERT MESSAGE GRAPHICS OVERLAY RECORD UTILITY
-----
BACK LAYOUT BONDING_DIAGRAM DISABLE_CURRENCY
ROUTE
FLOORPLAN
PAPER_DOLLS
-----

```

```

: PLOT:NEW_PLOT:
Figure A.73

```

```

*****
Chip ^gensettle/settle/tutor_chip Plot
-----Genesis1 Version v7 0-----
) Times real=40s; cpu=19s (u=12s, s=6 8s) (c=19s)
) Executing command COMPILE:LAYOUT -----in Chip /tutor_chip .
)
) Fabline VTC_CP10B Technology. CMOS-1
) Package not found.
) rcfreq02-U-I Clock net phase_a given to have a maximum frequency of 10.00 Mh
) z
) rcfreq02-U-I Clock net phase_b given to have a maximum frequency of 10.00 Mh
) z
) ROUTER maximum ir-drop voltages (mv) found:VSS 24 VCC 35
) ROUTER maximum ir-drop voltages (mv) found:VSS 24 VCC 35
) Package not found
) Chip size in um 2265 x 2221. in mils: 89.2 x 87.4
) Key Parameters (set 121) Modified
) Key Parameters (set 123) Modified
) Done with command COMPILE LAYOUT -----in Chip /tutor_chip
) Times real=186s; cpu=119s (u=97s, s=21s) (c=119s)
HF_PLOTTER
P_SIZE_PAPER
tutor
GC
) PLOT STATISTICS 3034 vectors, 12651 rectangles, 5872 line rectangles, 14324
) skipped rectangles
PLOT_FILE
HF7580A
tutor_1
) Plot is queued
) GCY
PLOT
NEW_PLOT
LAYOUT
) Checking file currency
) Internal Object Hierarchy Initialized
) Completing Data Gathering Phase
) All files are up to date
-----
INSERT MESSAGES GRAPHICS OVERLAY RECORD UTILITY
-----
BACK WORKSTATION
HF_PLOTTER
-----

: PLOT_NEW_PLOT:LAYOUT:

```

Figure A.74

```

*****
Chip: "gensettle/settle/tutor_chip" Plot
-----Genesis Version v7.0-----
Scale Factor 51.42 Rotate OFF
Number of pages (x by y): 1 by 1

Object Size (mils) 89.20 x 87.44
Window Size (mils) 89.20 x 87.44

Object Limits (mils) (-44.60,-43.72) (44.60,43.72)
Window Limits (mils) (-44.60,-43.72) (44.60,43.72)

Device Co-ord System Size 10000 x 5840
Viewport Co-ord System Size 10000 x 5840

Device Co-ord System Limits (0,0) (10000,5840)
Viewport Co-ord System Limits (0,0) (10000,5840)

```

```

-----
INSERT MESSAGE GRAPHICS FORM OVERLAY RECORD UTILITY
-----
CANCEL WINDOW SPLIT SELECT_LAYERS
RESET VIEWPORT OPTIMIZER_OFF
GO SCALE
ROTATE
-----

```

>PLOT:NEW_PLOT.LAYOUT:WORKSTATION>

Figure A.75

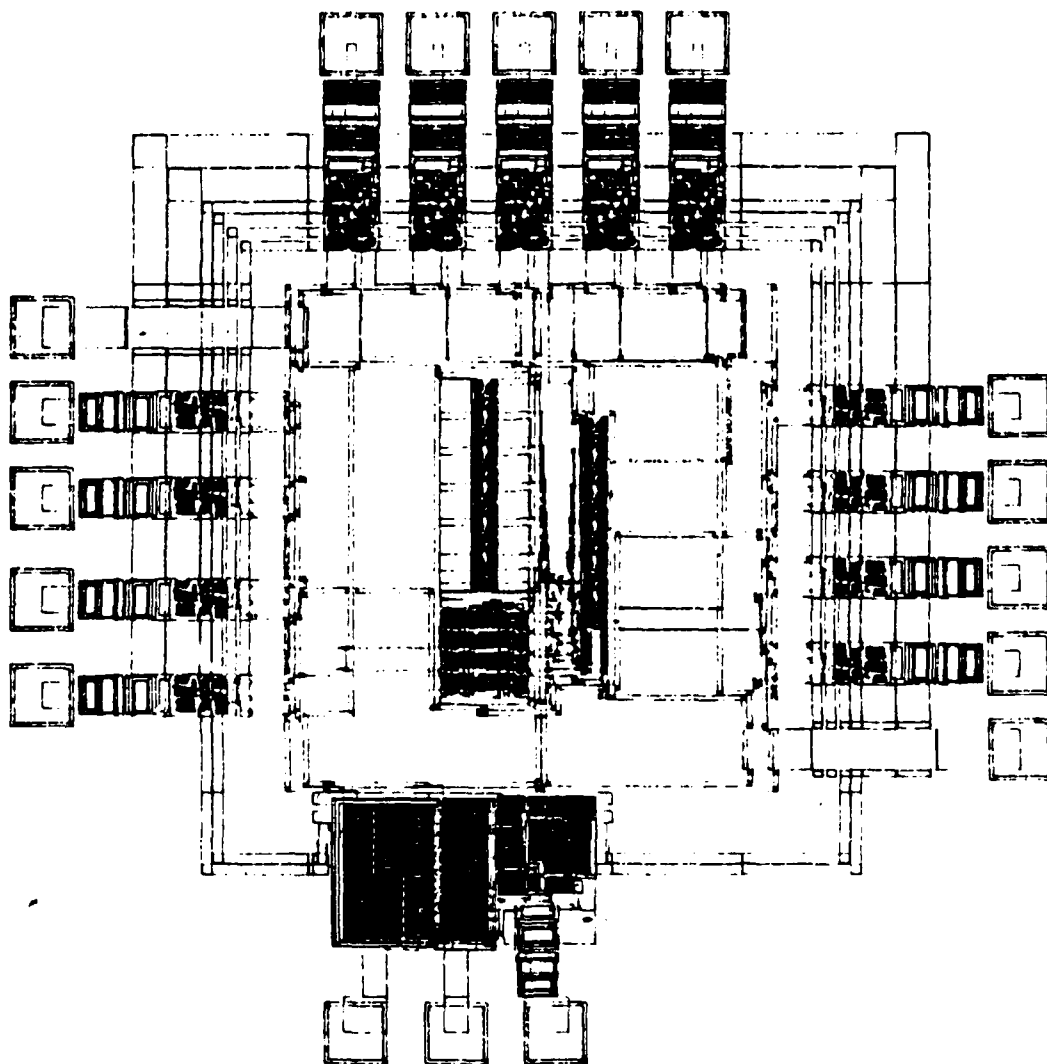

Figure A.76

LIST OF REFERENCES

1. VLSI Systems Design Staff, Directory of Silicon Compilers, VLSI Systems Design, March 1988.
2. Shou, S.H., Silicon Compilation Aids IC Design, Defense Electronics, September 1987.
3. Loomis, H.H. Jr., and Kirk, D.E., "Automated Design of VLSI Devices for Navy Space Applications", Unpublished Paper, Naval Postgraduate School, Monterey, CA, April 1987.
4. Doer, A., and Sabo, D., Silicon Compilation and Design for Test, Solid State Technology, August 1986.
5. Weste, N., and Eshragian, F., Principles of CMOS VLSI Design, A Systems Perspective, p.238, Addison-Wesley, October 1985.
6. Genesil System, System Description Users Manual, Silicon Compiler Systems Corp., San Jose, CA, 1986.
7. Genesil System Compiler Library Volume I, p.1-1, Silicon Compiler Systems Corp., San Jose, CA, 1986.
8. Genesil System, System Description Application Commands, Silicon Compiler Systems Corp., San Jose, CA, 1986.
9. Genesil System, Simulation Users Guide, Silicon Compiler Systems Corp., San Jose, CA, September 1987.
10. Genesil System, Timing Analysis Users Guide, Silicon Compiler Systems Corp., San Jose, CA, July 1987.
11. Stone, H.S., High Performance Computer Architecture, ch. 3, Addison-Wesley Publishing, 1987.
12. Rogge, P.M., The Architecture of Pipelined Computers, Hemisphere Publishing, 1981.
13. Genesil System Compiler Library Volume III Random Logic Module, Silicon Compiler Corp., 1986.
14. Triebel, W.A., Integrated Digital Electronics, 2nd ed., p. 233, Prentice-Hall, 1985.
15. Conradi, J.R., and Hauenstein, B.R., VLSI Design of a Very Fast Pipelined Carry Look Ahead Adder, Master's Thesis, Naval Postgraduate School, Monterey, CA, September 1983.

16. Simchik, R.J., VLSI Design of a Sixteen Bit Pipelined Multiplier Using Three Micron NMOS Technology, Master's Thesis, Naval Postgraduate School, Monterey, CA, June 1985.
17. Taub, H., Digital Circuits and Microprocessors, p. 208, McGraw-Hill, 1982.
18. Froede, A.O. III, Silicon Compiler Design of Combinational and Pipelined Adder Integrated Circuits, Master's Thesis, Naval Postgraduate School, Monterey, CA, June 1985.
19. Waser, S., and Flynn, M.J., Introduction to Arithmetic For Digital System Designers, pp 132-138, CBS College Publishing, 1982

INITIAL DISTRIBUTION LIST

	No. Copies
1. Defense Technical Information Center Cameron Station Alexandria, Virginia 22304-6145	2
2. Library, Code 0142 Naval Postgraduate School Monterey, California 93943-5002	2
3. Chairman, Code 62 Naval Postgraduate School Monterey, California 93943-5000	1
4. Curricular Officer, Code 32 Naval Postgraduate School Monterey, California 93943-5000	1
5. Prof. H. H. Loomis Jr., Code 62Lm Naval Postgraduate School Monterey, California 93943-5000	1
6. Prof. Chyan Yang, Code 62Ya Naval Postgraduate School Monterey, California 93943-5000	1
7. LTCOL Robert H. Settle 18501 Serrano Street Villa Park, California 92667	1
8. Commandant of the Marine Corps Code TE 06 Headquarters, U.S. Marine Corps Washington, D.C. 20360-0001	1
9. Commander Space and Naval Warfare Command PD-151 Washington, D.C. 20360	1
10. Naval Developmental Test Service Test Officer Joint Test Organization, Joint Tactical Command, Control, and Communication Agency Fort Huachuca, Arizona 85613	1
11. Curricular Officer, Code 32 Naval Postgraduate School Monterey, California 93943-5000	1

12. Mr. Gary Harmon
Silicon Compiler Systems Corporation
2045 Hamilton Avenue
San Jose, California 95125

1