

DTIC FILE COPY

4

TECHNICAL REPORT BRL-TR-2944

BRL

1938 - Serving the Army for Fifty Years - 1988

AD-A201 106

**COMBUSTION CHARACTERISTICS
OF CONSOLIDATED PROPELLANTS RESULTING
FROM DIFFERENT CONSOLIDATION TECHNIQUES**

J. OMAR DOALI
ARPAD A. JUHASZ
ROGER E. BOWMAN
WILLIAM P. AUNGST

NOVEMBER 1988

DTIC
ELECTE
NOV 21 1988
S **D**
H

APPROVED FOR PUBLIC RELEASE; DISTRIBUTION UNLIMITED.

U.S. ARMY LABORATORY COMMAND

**BALLISTIC RESEARCH LABORATORY
ABERDEEN PROVING GROUND, MARYLAND**

88 11 21 016

DESTRUCTION NOTICE

Destroy this report when it is no longer needed. DO NOT return it to the originator.

Additional copies of this report may be obtained from the National Technical Information Service, U.S. Department of Commerce, Springfield, VA 22161.

The findings of this report are not to be construed as an official Department of the Army position, unless so designated by other authorized documents.

The use of trade names or manufacturers' names in this report does not constitute indorsement of any commercial product.

REPORT DOCUMENTATION PAGE

1a. REPORT SECURITY CLASSIFICATION Unclassified		1b. RESTRICTIVE MARKINGS	
2a. SECURITY CLASSIFICATION AUTHORITY		3. DISTRIBUTION / AVAILABILITY OF REPORT APPROVED FOR PUBLIC RELEASE; DISTRIBUTION UNLIMITED	
2b. DECLASSIFICATION / DOWNGRADING SCHEDULE		5. MONITORING ORGANIZATION REPORT NUMBER(S)	
4. PERFORMING ORGANIZATION REPORT NUMBER(S) BRL-TR-2944		7a. NAME OF MONITORING ORGANIZATION	
6a. NAME OF PERFORMING ORGANIZATION Ballistic Research Laboratory	6b. OFFICE SYMBOL (If applicable) SLCBR-IB-A	7b. ADDRESS (City, State, and ZIP Code)	
6c. ADDRESS (City, State, and ZIP Code) Aberdeen Proving Ground, MD 21005-5066		9. PROCUREMENT INSTRUMENT IDENTIFICATION NUMBER	
8a. NAME OF FUNDING / SPONSORING ORGANIZATION	8b. OFFICE SYMBOL (If applicable)	10. SOURCE OF FUNDING NUMBERS	
8c. ADDRESS (City, State, and ZIP Code)		PROGRAM ELEMENT NO. 61102A	PROJECT NO. L162618AH80
		TASK NO. 00	WORK UNIT ACCESSION NO. 00
11. TITLE (Include Security Classification) Combustion Characteristics of Consolidated Propellants Resulting from Different Consolidation Techniques			
12. PERSONAL AUTHOR(S) J. Omar Doali, Arpad A. Juhasz, Roger E. Bowman, and William P. Aungst			
13a. TYPE OF REPORT Technical Report	13b. TIME COVERED FROM Oct 85 TO Sep 86	14. DATE OF REPORT (Year, Month, Day)	15. PAGE COUNT
16. SUPPLEMENTARY NOTATION			
17. COSATI CODES		18. SUBJECT TERMS (Continue on reverse if necessary and identify by block number)	
FIELD	GROUP	SUB-GROUP	
10	01	Consolidated Charges, Burning Rates M5 Propellant, Surface Area Profiles, Closed Chamber Tests,	
21	02	Propellant Progressivity JES	
19. ABSTRACT (Continue on reverse if necessary and identify by block number) <p>Three sets of propellant (M5) consolidated using different consolidation techniques were subjected to closed bomb firings. Each group of propellant increments (40 mm x 25 mm) was compacted to three densities ranging from 1.10 to 1.39 g/cc. Effective burning rates and surface area profiles were extracted from closed bomb data for comparison. Additionally, interrupted closed bomb burning experiments were performed in an attempt to detect differences in deconsolidation due to fabrication techniques. The picture which emerges from these studies is that sample deconsolidation is essentially complete at a very early stage (42 to 70 MPa) of the combustion cycle.</p>			
20. DISTRIBUTION / AVAILABILITY OF ABSTRACT <input type="checkbox"/> UNCLASSIFIED/UNLIMITED <input type="checkbox"/> SAME AS RPT. <input type="checkbox"/> DTIC USERS		21. ABSTRACT SECURITY CLASSIFICATION Unclassified	
22a. NAME OF RESPONSIBLE INDIVIDUAL J. Omar Doali		22b. TELEPHONE (Include Area Code) (301) 278-6103	22c. OFFICE SYMBOL SLCBR-IB-A

ACKNOWLEDGMENTS

We would like to express our sincere appreciation to Mr. Ludwig Stiefel and Mr. Frank Fortino, both for their advice and for their work in preparing the Dover samples. We further thank Dr. I.W. May, USA Ballistic Research Laboratory, for his assistance in designing the experiment.



Accession For	
NTIS GRA&I	<input checked="" type="checkbox"/>
DTIC TAB	<input type="checkbox"/>
Unannounced	<input type="checkbox"/>
Justification	
By	
Distribution/	
Availability Codes	
Avail and/or	
Dist	Special
A-1	

TABLE OF CONTENTS

	<u>Page</u>
LIST OF FIGURES.....	5
I. INTRODUCTION.....	7
II. FABRICATION TECHNIQUES.....	9
A. Hercules Inc., Magna, Utah.....	9
B. Consolidated Development Inc., (CDI), Marion, Virginia.....	10
C. SCWSL, Picatinny Arsenal, Dover, New Jersey.....	10
III. EXPERIMENTAL.....	11
IV. RESULTS AND DISCUSSION	
A. Burning Rate Comparisons.....	12
B. Surface Area Profiles.....	17
C. Interrupted Burning Comparisons.....	22
V. CONCLUSIONS.....	24
REFERENCES.....	25
DISTRIBUTION LIST.....	27

LIST OF FIGURES

<u>Figure</u>		<u>Page</u>
1	Surface Area vs Mass Fraction Burned Plots for Propellants with Various Geometries.....	8
2	Test Fixture for Consolidated Charge Firings.....	12
3	Burning Rate Data for Standard Loose M5 vs Loose Deterred M5.....	13
4	Comparison of Burning Rate Data from Standard Loose M5, Deterred M5, High Density Dover, High Density Hercules, and High Density CDI Consolidated Charges.....	14
5	Effect of Compaction Density on Effective Burning Rate Data from Hercules Consolidated Charges.....	15
6	Effect of Compaction Density on Effective Burning Rate Data from CDI Consolidated Charges.....	15
7	Effect of Compaction Density on Effective Burning Rate Data from Dover Consolidated Charges.....	16
8	Effective Burning Rate Data from Medium Density Dover, Hercules, and CDI Consolidated Charges.....	17
9	Surface Area vs Mass Fraction Plot for Standard Loose M5 Propellant.....	18
10	Reproducibility of Surface Area vs Mass Fraction Plots for Low Density CDI Consolidated Charges.....	19
11	Reproducibility of Surface Area vs Mass Fraction Plots for Medium Density CDI Consolidated Charges.....	20
12	Reproducibility of Surface Area vs Mass Fraction Plots for High Density CDI Consolidated Charges.....	20
13	Effect of Compaction Density on Surface Area Profiles of CDI Consolidated Charges.....	21
14	Effect of Compaction Density on Surface Area Profiles of Dover Consolidated Charges.....	21
15	Results of Interrupted Burning Experiments Using Single Increment Consolidated Charges.....	23
16	Result of Interrupted Burning Experiment. Using a Two Increment Dover Consolidated Charge.....	23

I. INTRODUCTION

Interest in consolidated charges has persisted for several years due to the potential advantages of an increase in propellant charge mass to projectile mass (c/m) ratio in a given volume. Essentially, this would result in better performance by increasing the amount of propellant energy available to do work on the projectile. Consolidated charges were initially studied as candidates for caseless applications.^{1,2} Later, interest developed in their use in high density cased ammunition,³ with subsequent investigations into the advantages of increased muzzle velocity, reduced ammunition size, and possible reduced temperature effects.⁴⁻⁶

However, problems such as difficulty in controlling the propellant mass generation profile resulting in excessive round to round variability have prevented the use of consolidated charges in fielded rounds. These problem areas have been investigated by Juhasz,⁷ Fortino,⁸ and May.⁹ The present effort is a continuation of previous studies¹⁰ and seeks to increase our knowledge of consolidated charge combustion.

¹J.B. Quinlan, E.F. VanArtsdalen, and M.E. Levy, "Combustible Ammunition for Small Arms I. Development of Self-Contained Propellant Charge (U)," Frankford Arsenal Report R-1552, May 1960, AD-239 174.

²M.E. Levy and M.S. Silverstein, "Survey of Combustible Cartridge Research and Development," Frankford Arsenal Report FA-1665, February 1963, AD-342 609.

³M.E. Levy and J.B. Quinlan, "High Loading Density Propellant Charges to Develop Increased Velocity," Frankford Arsenal Report FA R-1842, March 1967.

⁴F.E. Fortino, "Improved Ballistic Performance for 30-mm Ammunition Using Consolidated Charges," Frankford Arsenal TR-76064, September 1976.

⁵A.A. Milford and J.W. Silva, "25-mm Fully Telescoped Caseless Cartridge," Winchester Group Research, Olin Corporation, New Haven, Connecticut, Report WGR-72-234, March 1972.

⁶"Feasibility Demonstration of 30-mm Caseless/Consolidated Ammunition," Hercules, Inc., Systems Group, Bacchus Works, Magna, Utah, Report H237-12-4-1, Contract DAA25-72-0371, 3 October 1972.

⁷A.A. Juhasz, I.W. May, and L. Scott, "The Effects of Consolidation on the Burning of Gun Propellants," Proceedings of the 15th JANNAF Combustion Meeting, Newport, Rhode Island, Sep 1978, CPIA Publication 297, Feb 1979.

⁸F.E. Fortino, "Effects of Consolidation Parameters on the Burning of Consolidated Propellant Charges," 1979 JANNAF Propulsion Meeting, Anaheim, California, March 1979.

As mentioned above, the potential advantage of consolidated charges is the ability to increase the charge to mass ratio. However, for any given grain geometry there is a limit to the effect of increased charge weights on muzzle velocity. After a certain point, webs and dimensions can not be further optimized and muzzle velocity actually decreases with increased charge weight due to incomplete propellant burning.¹⁰ Complete burning would lead to pressures exceeding the allowable maximum. Presently, it is necessary to use increasingly progressive propellant geometries (Figure 1) in order to go to higher loading densities. The progressivity of the propellants yields initially low gasification rates before projectile motion, followed by increased gasification rates after increased volume is produced due to projectile motion. In this way, larger amounts of propellant may be burned without exceeding the maximum pressure rating of the gun. It has been shown that 19 perforated propellant grains permit loading densities up to about 0.9 g/cc.¹⁰ However, consolidation of propellants can result in loading densities up to and exceeding 1.35 g/cc. Exploitation of such high loading densities will depend upon whether or not consolidation provides the required increase in progressive burning through macroscopic progressivity.

The objective of this investigation was to study the effect of fabrication techniques on the combustion characteristics of consolidated charges.

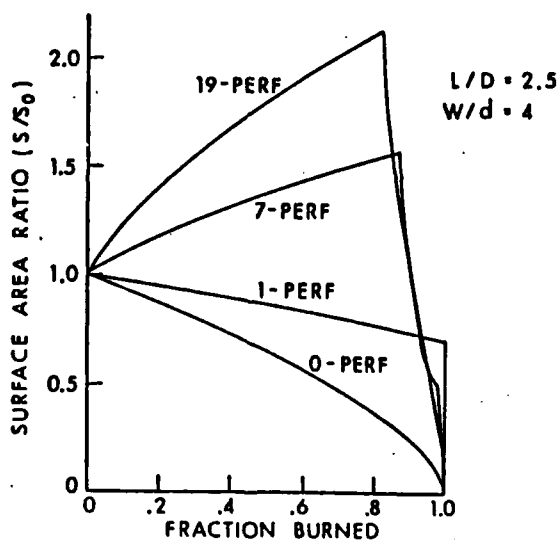

Figure 1. Surface Area vs Mass Fraction Burned Plots for Propellants with Various Geometries.

⁹I.W. May and A.A. Juhasz, "Combustion Processes in Consolidated Propellants," 10. Internationale Jahrestagung, ICT, Karlsruhe, Deutschland, June 1979.

¹⁰A.A. Juhasz, I.W. May, W.P. Aungst, J.O. Doali, and R.E. Bowman, "Combustion Characteristics of Consolidated Propellants," Proceedings of the 16th JANNAF Combustion Meeting, Monterey, California, September 1979, CPIA Publication No. 308, December 1979.

II. FABRICATION TECHNIQUES

The propellant used in this study was a single perforation, double base propellant, M5, Lot RAD-64597. The composition, dimensions, and thermochemistry of the propellant are given in Table I. The propellant was processed using three different procedures by three different organizations. In all cases, the final product was a wafer or "puck" approximately 25.4 mm thick and 36 mm in diameter. Each of the three procedures also produced samples in three compaction densities: low (1.10-1.20 g/cc), medium (1.25-1.28 g/cc), and high (1.35-1.39 g/cc).

TABLE I. COMPOSITION, THERMOCHEMICAL AND GEOMETRY DATA; RAD 64597

<u>Ingredient</u>	<u>Percent</u>	<u>Geometry Data</u>
Nitrocellulose (13.24)	81.65	
Nitroglycerin	15.27	length 0.266"
Ethyl Centralite	0.52	diameter 0.053"
Potassium Nitrate	0.82	perf. 0.016"
Barium Nitrate	1.41	web 0.019"
Graphite	0.33	
Moisture	0.30	
Volatiles	1.85	
Graphite Glaze	0.04	
Impetus (ft-lb/lb)	365224.00	
Flame Temperature (K)	3380.00	
Molecular Weight of Gas	25.72	
Co-Volume (in ³ /lb)	27.11	
GAMMA (ratio of sp hts)	1.22	

A. Hercules Inc., Magna, Utah

The following brief description of the Hercules process is excerpted from their contract report.¹¹

"The loose, dry propellant is weighed out to the desired weight within a tolerance of ±0.04 gram. The propellant is then placed in a mixer cup which is then placed on the solvator. In the solvator, acetone vapor is blown into the cup as the cup is rotated on its side. At a predetermined time, the cup weight is checked to determine if sufficient acetone has been absorbed. A weight tolerance of ±0.07 gram is applied at this point. The solvated propellant is transferred to the mold in a press and pressed to the desired length. The mold is held in the closed position for 60 seconds and the wafer is removed. The wafer is placed in an air circulating oven at

¹¹L.R. Scott, "Traveling Charge Consolidated Propellant, Volume I - Preparation of Consolidated Charge Increments," USA AMCCOM, Ballistic Research Laboratory Contractor Report (ARBRL-CR-00408), November 1979.

68°C ±2°. Periodic weighing is used to determine when the wafers are cured. The cured weight tolerance is ±0.07 gram applied to the initial propellant nominal weight. The cured wafers are inhibited on the perimeter, when applicable, with EA-946 epoxy (Hysol Division, Bendix Corp.) applied by hand with a paint brush. An effort is made at the time of coating to fill all voids in the perimeter surface with the epoxy. The wafers are then cured at room temperature."

B. Consolidated Development Inc. (CDI), Marion, Virginia

The information given to us by CDI was meager because the company considered the process to be proprietary in nature. In general, the process involved vapor phase solvation of the propellant grains using a mixture of 75% acetone and 25% ethanol. After pressing for a prescribed period of time, the wafers were forced air dried at 50°C for 24 hours. The perimeters of these charges were also epoxy coated.¹²

C. SCWSL, Picatinny Arsenal, Dover, New Jersey

This work was performed under the direction of Mr. Ludwig Stiefel.¹³ The process involved coating the propellant grains prior to pressing with a binder (a deterrent) of the following composition:

20 grams. . . .Nitrocellulose (12.6% N)
2 grams. . . .Di-n-butyl phthalate
378 grams. . . .Acetone

A total of 0.1 cc of binder solution was used per gram of propellant. The required amount of binder solution was added to the propellant which was stirred manually to obtain good distribution. The binder-wet propellant was then transferred to the mold and pressed. Drying was done in a forced convection oven at 55°C. Drying was stopped when the desired residual solvent (acetone) level was achieved. The residual solvent levels for the high density, medium density, and low density samples were respectively, 0.49%, 0.52%, and 0.64%. The loose coated propellant had a residual solvent level of 0.36%. The perimeters of these consolidated charges were not coated with epoxy. In the discussion to follow, these charges will be referred to as the Dover samples.

The charge weights and sample compaction densities of the charges resulting from the three different procedures are given in Table II.

¹²Mr. David Cary, Consolidated Development, Inc., Marion, Virginia, Personal Communication.

¹³Mr. Ludwig Stiefel, SCWSL, Picatinny Arsenal, Dover, New Jersey, Personal Communication.

TABLE II. CONSOLIDATED CHARGE SAMPLES

<u>Manufacturer</u>	<u>Lot</u>	<u>Density (g/cc)</u>	<u>Weight (g)</u>
Hercules	HI-1-20	1.20	29.35
	HI-1-22	1.25	31.97
	HI-1-24	1.35	34.51
CDI	0982-02	1.10	29.24
	0982-01	1.25	32.99
	0982.03	1.35	35.64
Dover	Low density	1.12	29.35
	medium density	1.28	31.87
	high density	1.39	34.60

III. EXPERIMENTAL

Closed chamber tests were performed on samples using the test fixture described in Figure 2. The chamber cavity was 40 mm in diameter and 177 mm long. Experimental loading densities ranged from 0.17 to 0.41 grams per cubic centimeter depending on propellant compaction density and whether a single or a two-increment sample was fired. Single-increment charges were cemented into stainless steel tubes 25 mm long, 39.9 mm outer diameter, and 36.4 mm inner diameter by coating the perimeter of the charges with epoxy. The steel sleeve was then coated with epoxy and cemented in the end of the chamber opposite the firing head. The same procedure was followed with the two-increment charges except that the steel sleeve was 50 mm long. Samples were ignited using 1.2 grams of black powder pellets and an Atlas M-100 electric match. In addition to standard closed bomb studies, interrupted burning experiments were performed in order to better understand the deconsolidation process. These required modification of the firing head to contain a blow-out device. Numerous types of blow-out devices were tried including various metal discs and even rubber stoppers. One problem was that if the blow-out pressure was too low, the propellant was not extinguished. Another was that the blow-out pressures varied according to the loading density, with the higher loading densities producing higher blow-out pressures. The most consistent success was obtained using 0.63 mm thick tempered aluminum discs. In these experiments, a drop cloth was spread out in front of the chamber to catch unburned propellant for inspection. Pressure measurements were made with Kistler 607C3 transducers and Kistler model 504E charge amplifiers. Data acquisition was performed using a Nicolet Explorer III digital oscilloscope followed by data reduction on a PDP 11/34 minicomputer using the CBRED2 program.¹⁴

¹⁴C.F. Price, T.L. Boggs, R. Gould, J.L. Eisel, and D.E. Zurn, "CBRED II Program as Used With Closed Bomb Testing of Damaged Propellant From LAM and Shotgun Tests," 15th JANNAF Combustion Meeting, 11-15 September 1978, Newport, Rhode Island, CPIA Publication 297, Feb 1979, pp. 143-158.

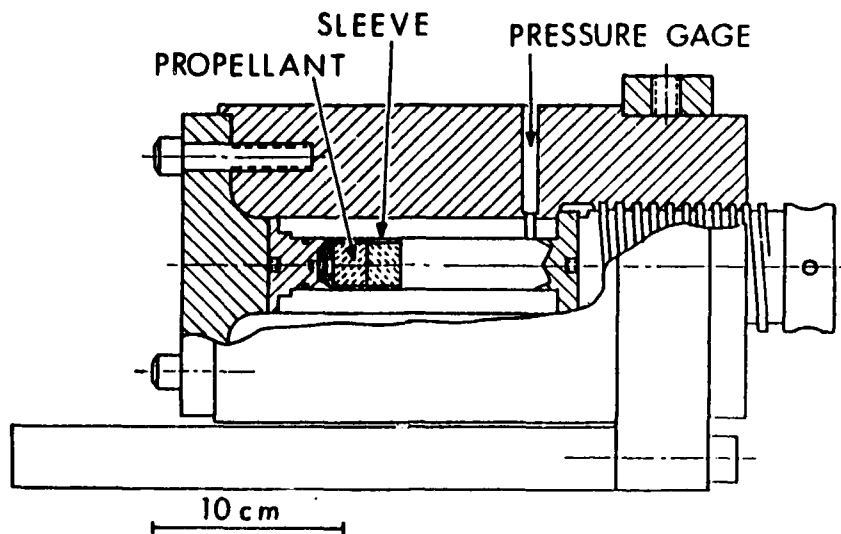

Figure 2. Test Fixture for Consolidated Charge Firings.

IV. RESULTS AND DISCUSSION

A. Burning Rate Comparisons

Initially, the data were compared by computing the burning rates of the granular propellant and the effective burning rates of the consolidated charges assuming loose propellant geometries. It is important to note that the Dover data were reduced using slightly different thermochemical parameters in an attempt to compensate for the deterred surface of the grains. As a result, comparison among Dover samples is valid but there may be some degree of uncertainty when Dover burning rates and those of other samples are compared. The typical burning rate curves of granular M5 propellant and the Dover deterred propellant are compared in Figure 3. The deterred propellant exhibits an overall lower burning rate above 12 MPa. Further, a break in the slope of the deterred propellant occurs at about 48 MPa. The overall lower burning rate of the deterred propellant may be due to the diffusion of the deterrent into the interior of the grains.

To obtain a comparison between granular consolidated propellants, it was necessary to extract effective burning rates from the combustion of consolidated charges. This was done by performing normal closed bomb data reductions assuming that the original geometry of the propellant has not changed. This lumps the geometric change into the "linear burning rate" of the propellant. As a result, the greater the change in sample geometry, the greater the difference between the loose propellant burning rate and the effective burning rates of the consolidated grains. Grain collapse or

incomplete deconsolidation will lower the effective burning rate while essentially complete deconsolidation or grain fracture will result in no change or even an increase.

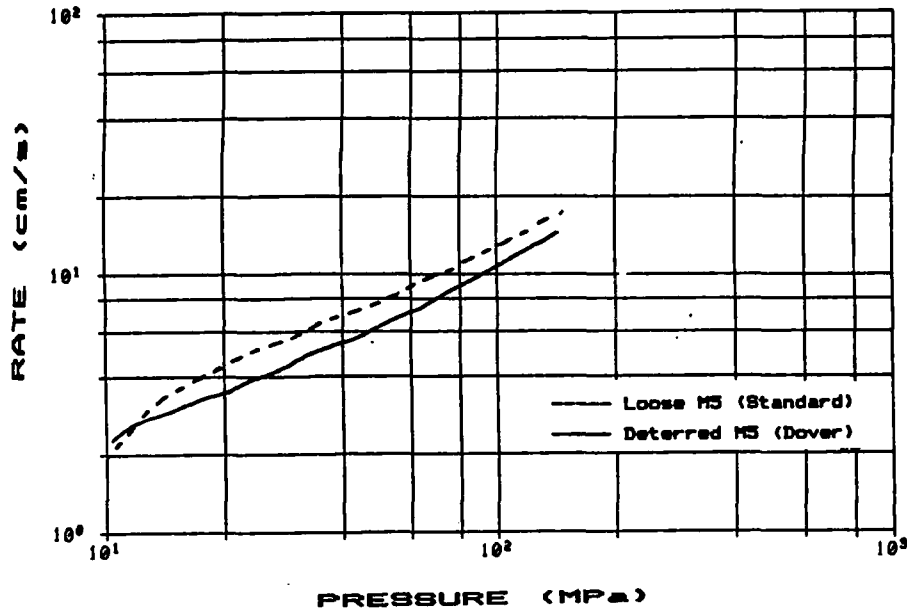

Figure 3. Burning Rate Data for Standard Loose M5 vs Loose Deterred M5.

The reproducibility of the effective burning rates obtained from the consolidated charges was as good as the data obtained from granular propellant combustion. For all compaction densities, the Dover samples exhibited the best reproducibility down to approximately 28 MPa. Figure 4 compares the burning rate curves obtained from granular M5 combustion and the effective burning rate curves extracted from the three different high density consolidated charges. The anomalous behavior which we observe in the low pressure region of these curves and the following burning rate curves may be due to the influence of delayed gas phase kinetics and/or hydrodynamic effects. An in-depth investigation of this region is needed. Of the three sources, the charges fabricated by CDI produced the highest effective burning rates. Therefore, the high density CDI charges apparently deconsolidate producing fewer aggregates and/or more fractured grains. Note that the Dover curve exhibits an overall higher slope in comparison with the other curves indicating a somewhat greater degree of progressivity. The effects of compaction density and processing techniques within each group of samples upon the effective burning rates are shown in Figures 5, 6, and 7. Examination of the curves obtained from the Hercules samples (Figure 5) indicates that all charges are deconsolidating in a similar manner regardless of compaction density, implying that the Hercules process is well controlled. The CDI charges (Figure 6) produced similar low medium density burning rate curves but the high density sample yielded a curve with a

slightly higher burning rate. The greatest disparity in effective burning rate curves (Figure 7) resulted from the reduction of the Dover data. Obviously, the medium density charges are deconsolidating in the more desired manner. Judging by the procedure described for the preparation of these samples, it is not clear why there should be such a difference in effective burning rates.

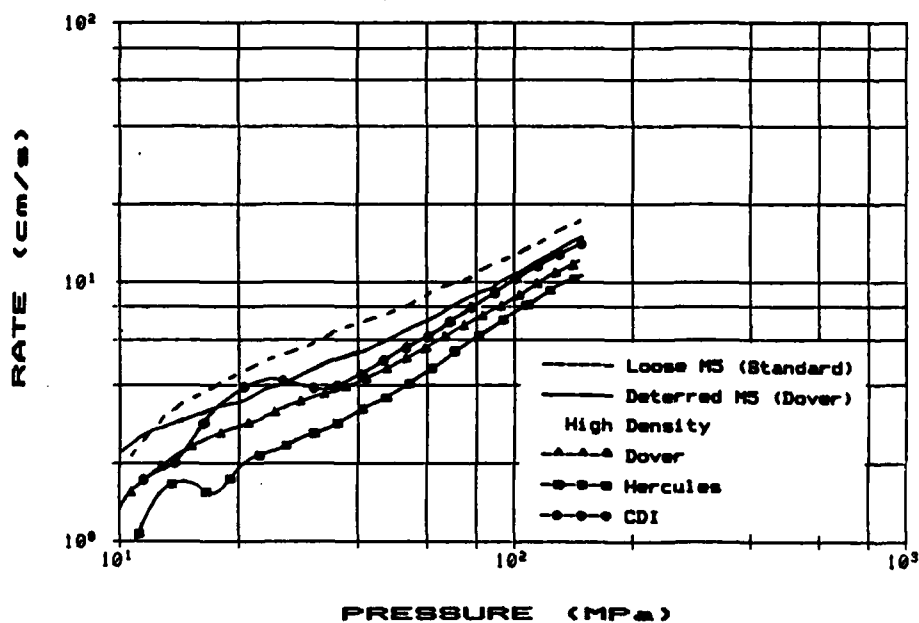

Figure 4. Comparison of Burning Rate Data from Standard Loose M5, Deterred M5, High Density Dover, High Density Hercules, and High Density CDI Consolidated Charges.

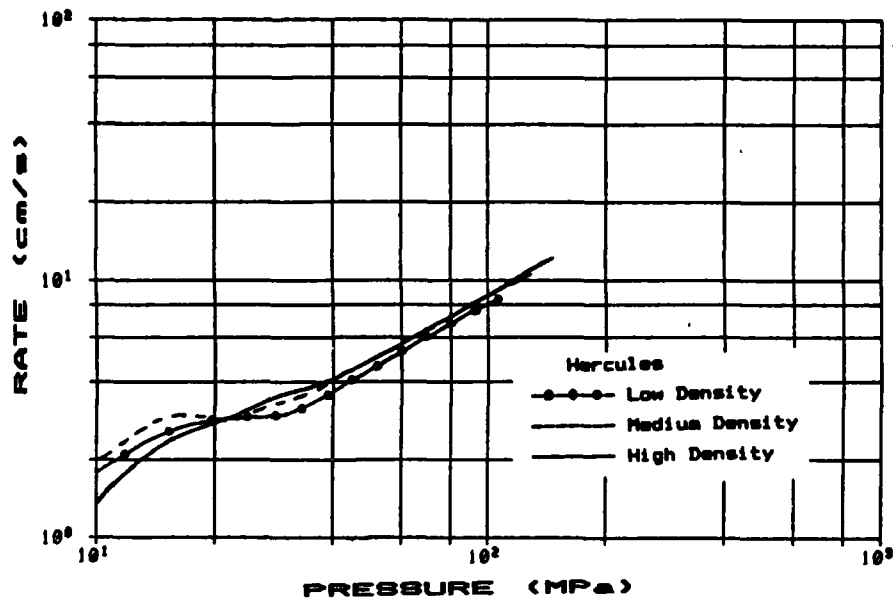

Figure 5. Effect of Compaction Density on Effective Burning Rate Data from Hercules Consolidated Charges.

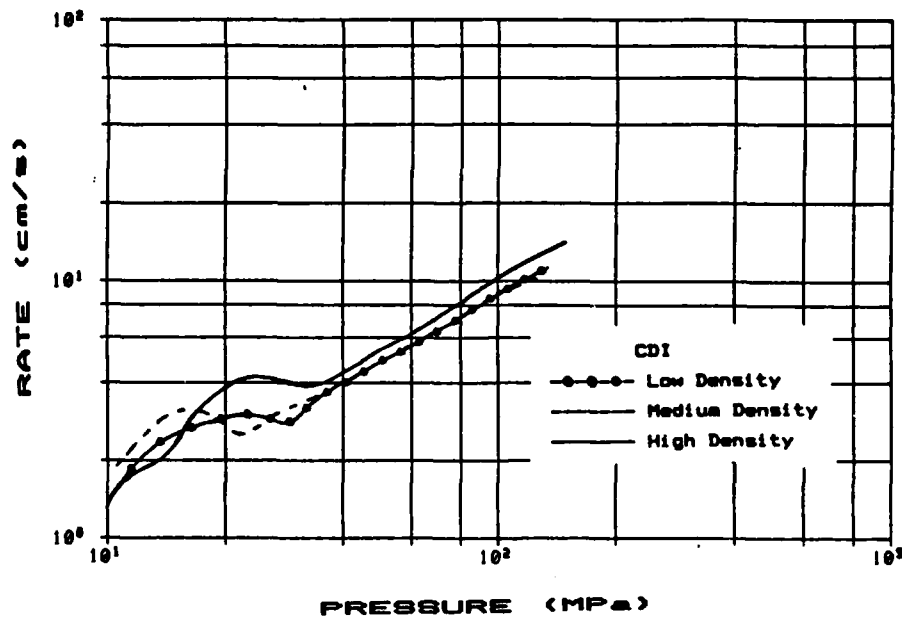

Figure 6. Effect of Compaction Density on Effective Burning Rate Data from CDI Consolidated Charges.

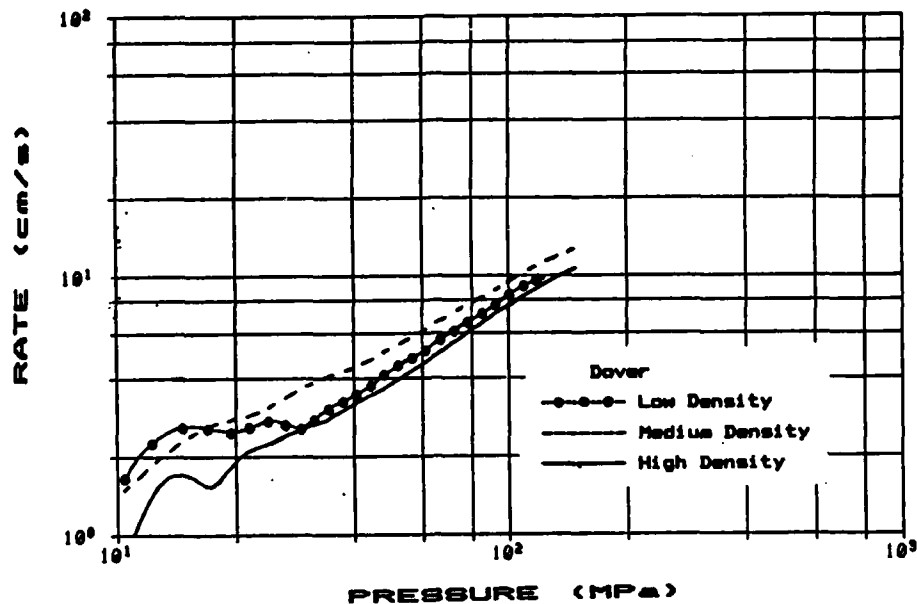

Figure 7. Effect of Compaction Density on Effective Burning Rate Data from Dover Consolidated Charges.

A comparison of the compaction densities of each fabrication technique with the resulting effective burning rates proves informative. Reexamination of Figure 4 shows the large difference in effective burning rates obtained from the three high density samples. In contrast, as seen in Figure 8, the three medium density samples show little difference in effective burning rates. The results may be strictly fortuitous, in that at this compaction density, the mechanical strength of the grains, applied pressures, and solvent retention combined uniquely to produce a more uniform product. Additionally, agreement between the effective burning rates of the three different low density samples was nearly as good as that obtained for the medium density charges. Clearly, the greatest effect of processing techniques is in the high density charges where it is probable that grain collapse and variability in solvent retention may play a major role.

Finally, all of the effective burning rate curves of the consolidated charges result in higher burning rate exponents than found for the loose propellant. This indicates that some macroscopic progressivity expected from charge breakup is indeed occurring.

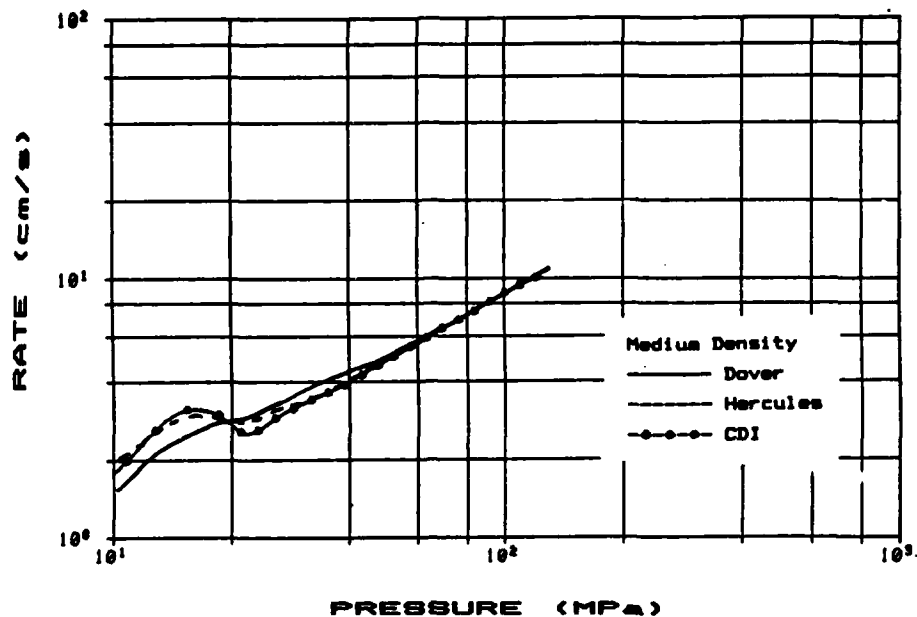

Figure 8. Effective Burning Rate Data from Medium Density Dover, Hercules, and CDI Consolidated Charges.

B. Surface Area Profiles

To determine to what degree progressivity was achieved by the consolidated charges, it was necessary to develop surface area vs mass fraction burned plots. The procedure and assumptions involved in this task are discussed in detail in the report by A. Juhasz, et al.¹⁰ The process involves a "inverse" closed bomb data reduction. The rate of propellant gas mass generation (dm/dt) in the closed bomb is governed by the expression:

$$dm/dt = \rho s r$$

where ρ is the propellant density, s is the instantaneous surface area, and r is the linear burning rate. As a result, knowing dm/dt and the propellant density, either the surface area or the burning rate can be found if one or the other is known. In this case the burning rate for loose M5 propellant was used as an input in CBRED2 to obtain the corresponding surface area profile (S/S_0 vs mass fraction burned). The ratio, S/S_0 , is determined by dividing the instantaneous surface area by the initial surface area of the propellant. The result of a typical run using standard loose M5 propellant is given in Figure 9. The dotted line represents the ideal surface area vs mass fraction burned for the propellant grains while the solid line represents the calculated experimental surface area vs charge mass fraction burned. We see that there is good agreement between the ideal and the experimental curves over the 0.1 to 0.8 mass fraction range. The influence

of ignition effects flamespread in the loose propellant bed, early low level pressure waves, and heat loss effects are expected to cause deviations outside this range.

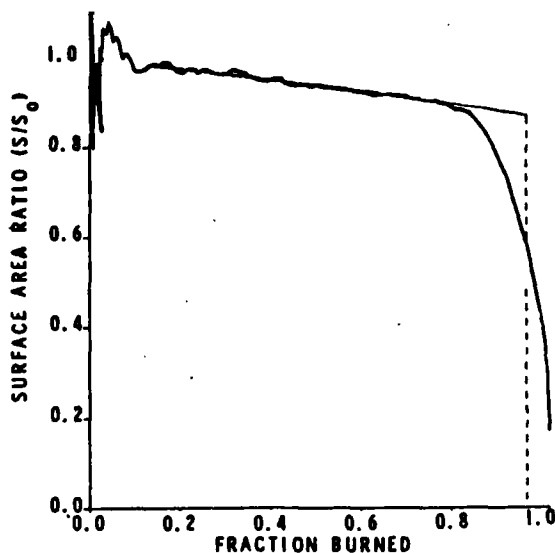

Figure 9. Surface Area vs Mass Fraction Plot for Standard Loose M5 Propellant.

To obtain the surface area profiles for the consolidated charges, the surface area ratio (S/S_0) was computed by dividing the experimentally calculated surface area by the initial surface area of an equivalent charge weight of loose propellant. The exceptional reproducibility shown in Figures 10, 11, and 12 for the CDI charges was also typical of the other charges. These results are a major improvement over those previously reported.¹⁰ Obviously, the black powder pellet ignition system used in the study has resulted in a more controlled charge breakup regardless of compaction density and fabrication procedure. The black powder pellet ignition system was chosen on the basis of an earlier ignition sensitivity study of the base propellant.¹⁵ The improvement in round to round reproducibility via a tailored ignition system is an important breakthrough in the development of consolidated charges.

The effects of compaction density upon the surface area profiles are shown in Figures 3 and 14. The results obtained from the CDI samples (Figure 13) are similar to those produced by the Hercules charges. As the

¹⁵A.A. Juhasz and I.W. May, "Igniter Effects on M5 Closed Bomb Burning Rates," Proceedings of the 18th JANNAF Combustion Meeting, Pasadena, California, October 1981, CPIA Publication 347, October 1981.

compaction density increased, the surface area became more enhanced. However, the surface area profile curves from the Hercules charges were very close together which correlates well with the apparently more consistent charge breakup as evidenced by the effective burning rate curves. As seen in Figure 14, the trend in surface area profiles is not repeated in the Dover data. The medium density charges produced a more enhanced surface area than the high density charges. This difference might be better understood by an investigation of the mechanical properties of the various charges and the determination of residual solvent content. Examination of the above surface area profiles reveals that in all cases, there is some degree of progressivity compared to the base grain. However, there is no evidence that one fabrication technique is substantially better than another in enhancing this effect. As mentioned previously there is anomalous behavior in the surface area profiles below 0.1 mass fraction burned. This is not surprising since these data are derived from the burning rate data which also exhibit anomalous behavior in the low pressure region. Chemical, optical, and x-ray diagnostic experiments need to be performed to better understand the combustion phenomena in the low pressure region.

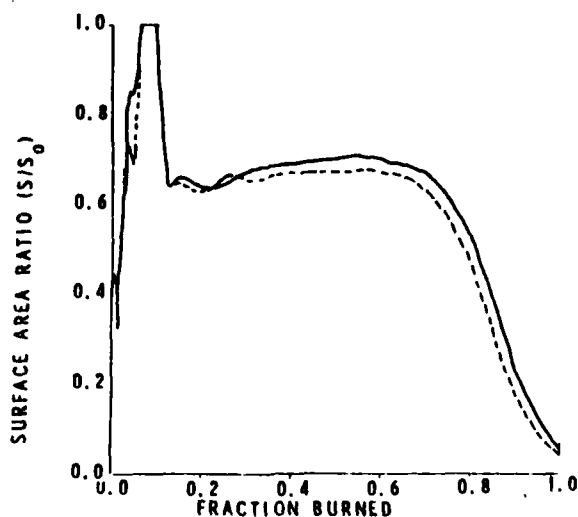

Figure 10. Reproducibility of Surface Area vs Mass Fraction Plots for Low Density CDI Consolidated Charges.

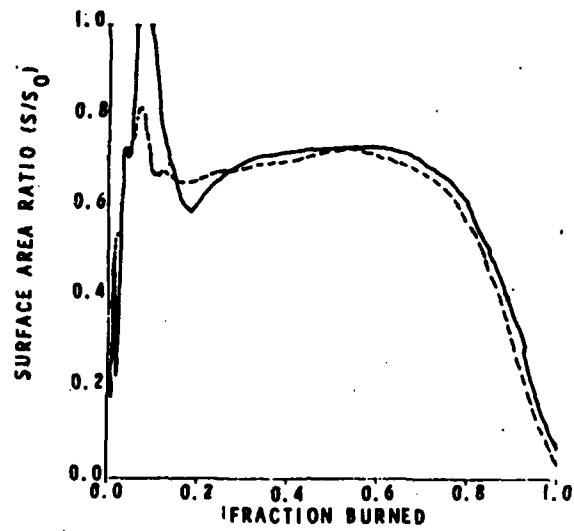

Figure 11. Reproducibility of Surface Area vs Mass Fraction Plots for Medium Density CDI Consolidated Charges.

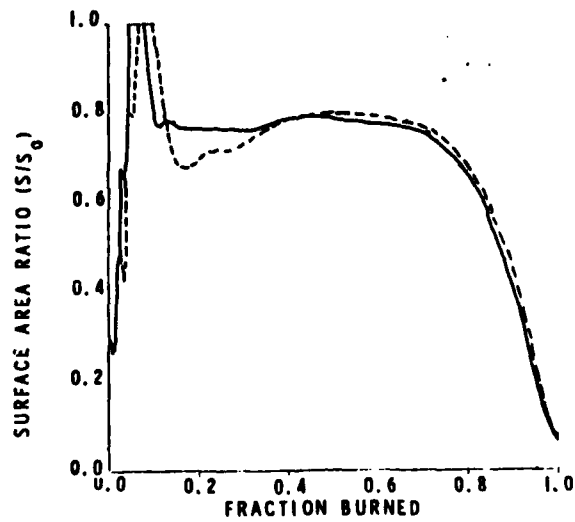

Figure 12. Reproducibility of Surface Area vs Mass Fraction Plots for High Density CDI Consolidated Charges.

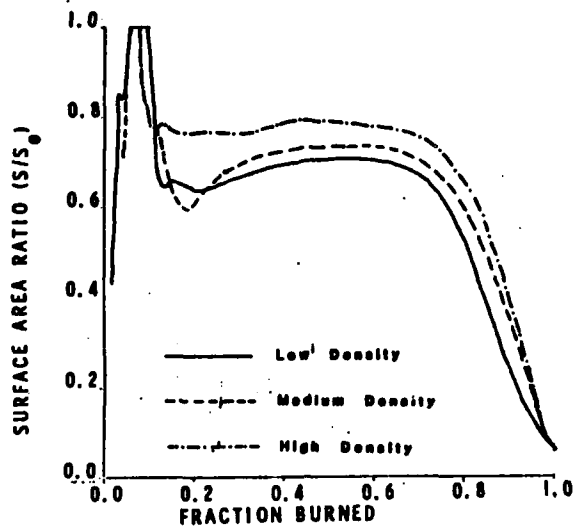

Figure 13. Effect of Compaction Density on Surface Area Profiles of CDI Consolidated Charges.

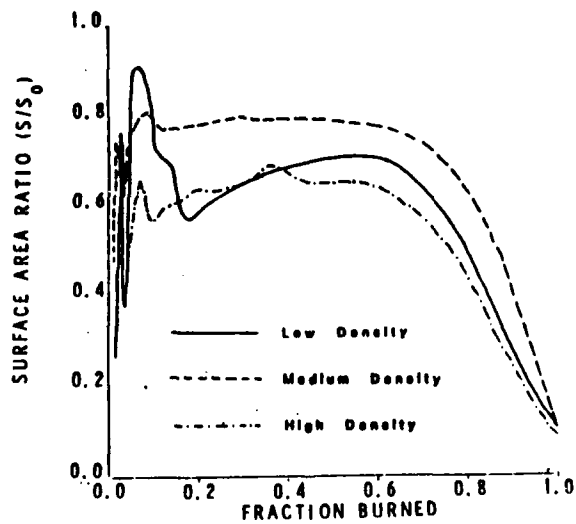

Figure 14. Effect of Compaction Density on Surface Area Profiles of Dover Consolidated Charges.

C. Interrupted Burning Comparisons

To obtain a better understanding of the deconsolidation process during combustion, a series of interrupted burning studies were performed as described in the experimental section. The first experiments involved duplicate firings of the three different high density single-increment charges. It was found that the blow-out discs ruptured in the pressure range of 28 MPa to 35 MPa. Under these conditions, approximately 30% of the original propellant weight remained within the steel sleeve in a consolidated state. The unburned loose grains and aggregates remaining in the chamber and those ejected from the chamber were examined microscopically. In all cases, there were varying degrees of grain collapse with perforation dimensions ranging from nonexistent to the original state but there were very few fractured grains. In some cases, there was a reddish exudate on the surface of the grains which may indicate a pre-ignition pyrolysis condition. Additionally, most of the grains were sticky and easily adhered to one another. The number of aggregates were few in comparison to individual grains. It was not possible to conclude whether there was a different distribution of individual grains, aggregates, or fractured grains among the three charges. The most interesting information obtained from these experiments is shown in Figure 15. We see that the CDI and the Hercules charges apparently deconsolidated and burned from the center toward the steel sleeve. However, the Dover charge deconsolidated and burned in "cigarette fashion" leaving a disc-shaped portion of consolidated propellant in the rear of the steel sleeve. Obviously, the deterred coating and/or binder effects produced the desired flamespread through the charge. Ideally, this is the type of burning that is needed in a consolidated charge. To determine whether the flamespread characteristics of the Dover charges held true for two-increment samples, interrupted burning experiments were performed at approximately 9 MPa. Figure 16 shows that, indeed the two-increment charge deconsolidated in the same mode as the single-increment charges. Another series of interrupted burning experiments involving single and double-increment charges indicated that all charges completely deconsolidated within the pressure range of 42 MPa to 70 MPa. Since consolidated charges are expected to function at much higher pressures than those produced in these closed bomb firings, these charges are breaking up too low a pressure to produce the needed progressivity.

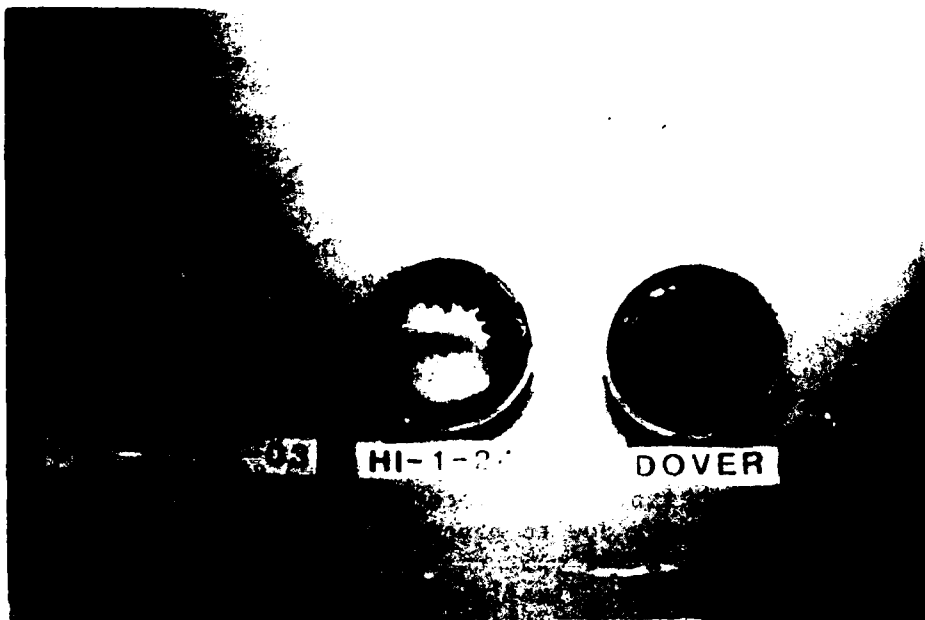

Figure 15. Results of Interrupted Burning Experiments Using Single-Increment Consolidated Charges.

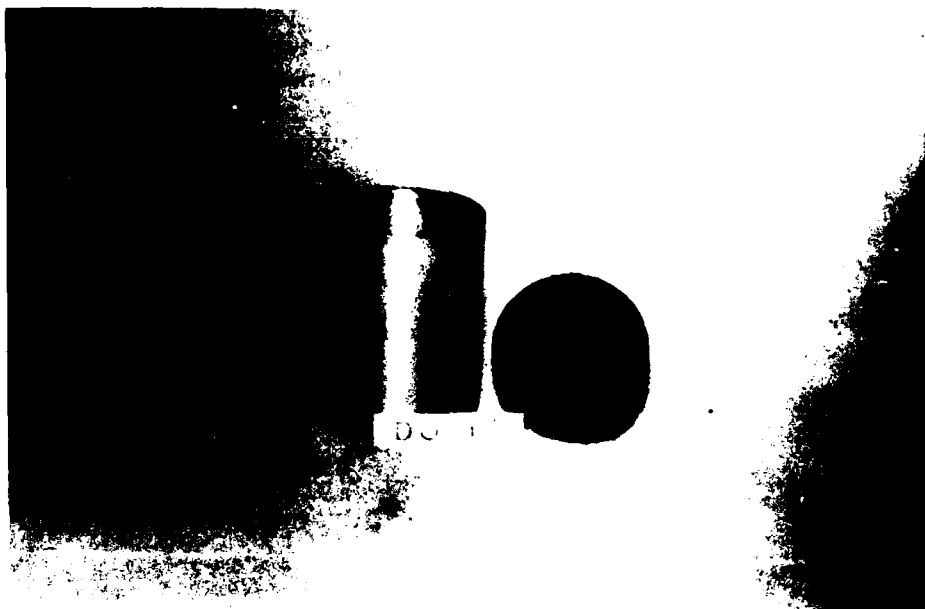

Figure 16. Result of Interrupted Burning Experiment Using a Two-Increment Dover Consolidated Charge.

V. CONCLUSIONS

The reproducibility of effective burning rates for all samples was much better than expected, with the Dover charges showing the best reproducibility. Additionally, the effective burning rate curves of the high density Dover samples indicated increased progressivity relative to the other samples. Furthermore, all charges yielded effective burning rates with higher exponents than the base grains. The CDI high density samples produced the highest effective burning rates. This was probably caused by a weaker binding effect due to the acetone/ethanol solvent system used in their process. The Hercules process was found to give more consistent results regardless of compaction densities. The surface area profiles of all samples also showed very good reproducibility which we feel demonstrates the improved ignition characteristics due to the use of black powder pellets. Though the surface area profiles showed some difference in surface area enhancement due to fabrication techniques, there was no obvious difference in progressivity due to processing. Most importantly, the high density Dover charges were the only charges which deconsolidated in the desired "cigarette fashion". Finally, it is disappointing to note that all charges deconsolidated at too low a pressure to achieve the macroscopic progressivity that is needed.

As a result of these observations, several areas of investigation are indicated. There is a need for a thorough study of the mechanical properties of candidate propellant grains and the consolidated charges resulting from varying processing techniques. A relatively strong base grain with a length to diameter ratio of about one appears desirable. This results in less grain distortion and collapse. There is also the need to assess various binders in order to increase the pressures at which deconsolidation occurs. The binders may also have a desired deterring effect, helping to moderate charge breakup, flamespread, and initial mass generation from the deconsolidated grains. The results obtained from the Dover samples corroborate this idea. An in-depth investigation into the early stages of combustion using chemical, optical, and x-ray methods is also needed to better understand the anomalous results obtained in the low pressure region. One or more of these areas will constitute the next phase in our investigations.

REFERENCES

1. J.B. Quinlan, E.F. VanArtsdalen, and M.E. Levy, "Combustible Ammunition for Small Arms I. Development of Self-Contained Propellant Charge (U)," Frankford Arsenal Report R-1552, May 1960, AD-239 174.
2. M.E. Levy and M.S. Silverstein, "Survey of Combustible Cartridge Research and Development," Frankford Arsenal Report FA-1665, February 1963, AD-342 609.
3. M.E. Levy and J.B. Quinlan, "High Loading Density Propellant Charges to Develop Increased Velocity," Frankford Arsenal Report FA R-1842, March 1967.
4. F.E. Fortino, "Improved Ballistic Performance for 30-mm Ammunition Using Consolidated Charges," Frankford Arsenal TR-76064, September 1976.
5. A.A. Milford and J.W. Silva, "25-mm Fully Telescoped Caseless Cartridge," Winchester Group Research, Olin Corporation, New Haven, Connecticut, Report WGR-72-234, March 1972.
6. "Feasibility Demonstration of 30-mm Caseless/Consolidated Ammunition," Hercules, Inc., Systems Group, Bacchus Works, Magna, Utah, Report H237-12-4-1, Contract DAA25-72-0371, 3 October 1972.
7. A.A. Juhasz, I.W. May, and L. Scott, "The Effects of Consolidation on the Burning of Gun Propellants," Proceedings of the 15th JANNAF Combustion Meeting, Newport, Rhode Island, Sep 1978, CPIA Publication 297, Feb 1979.
8. F.E. Fortino, "Effects of Consolidation Parameters on the Burning of Consolidated Propellant Charges," 1979 JANNAF Propulsion Meeting, Anaheim, California, March 1979.
9. I.W. May and A.A. Juhasz, "Combustion Processes in Consolidated Propellants," 10. Internationale Jahrestagung, ICT, Karlsruhe, Deutschland, June 1979.
10. A.A. Juhasz, I.W. May, W.P. Aungst, J.O. Doali, and R.E. Bowman, "Combustion Characteristics of Consolidated Propellants," Proceedings of the 16th JANNAF Combustion Meeting, Monterey, California, September 1979, CPIA Publication No. 308, December 1979.
11. L.R. Scott, "Traveling Charge Consolidated Propellant, Volume I - Preparation of Consolidated Charge Increments," USA AMCCOM, Ballistic Research Laboratory Contractor Report (ARBRL-CR-00408), November 1979.
12. Mr. David Cary, Consolidated Development, Inc., Marion, Virginia, Personal Communication.
13. Mr. Ludwig Stiefel, SCWSL, Picatinny Arsenal, Dover, New Jersey, Personal Communication.

14. C.F. Price, T.L. Boggs, R. Gould, J.L. Eisel, and D.E. Zurn, "CRED II Program as Used With Closed Bomb Testing of Damaged Propellant From LAM and Shotgun Tests," 15th JANNAF Combustion Meeting, 11-15 September 1978, Newport, Rhode Island, CPIA Publication 297, Feb 1979, pp. 143-158.
15. A.A. Juhasz and I.W. May, "Igniter Effects on M5 Closed Bomb Burning Rates," Proceedings of the 18th JANNAF Combustion Meeting, Pasadena, California, October 1981, CPIA Publication 347, October 1981.

DISTRIBUTION LIST

<u>No. of Copies</u>	<u>Organization</u>	<u>No. of Copies</u>	<u>Organization</u>
12	Administrator Defense Technical Info Center ATTN: DTIC-FDAC Cameron Station, Bldg 5 Alexandria, VA 22304-6145	5	Project Manager Cannon Artillery Weapons System, ARDC, AMCCOM ATTN: AMCPM-CW, AMCPM-CWW AMCPM-CWS M. Fisette AMCPM-CWA H. Hassmann AMCPM-CWA-S R. DeKleine Dover, NJ 07801-5001
1	Commander USA Concepts Analysis Agency ATTN: D. Hardison 8120 Woodmont Avenue Bethesda, MD 20014-2797		
1	HQDA/DAMA-ZA Washington, DC 20310-2500	2	Project Manager Munitions Production Base Modernization and Expansion ATTN: AMCPM-PBM, A. Siklosi AMCPM-PBM-E, L. Laibson Dover, NJ 07801-5001
1	HQDA, DAMA-CSM, Washington, DC 20310-2500		
1	HQDA/SARDA Washington, DC 20310-2500		
1	C.I.A. OIR/DB/Standard GE47 HQ Washington, D.C. 20505	3	Project Manager Tank Main Armament System ATTN: AMCPM-TMA, K. Russell AMCPM-TMA-105 AMCPM-TMA-120 Dover, NJ 07801-5001
1	Commander US Army War College ATTN: Library-FF229 Carlisle Barracks, PA 17013	1	Commander US Army Watervliet Arsenal ATTN: SARWV-RD, R. Thierry Watervliet, NY 12189-5001
1	US Army Ballistic Missile Defense Systems Command Advanced Technology Center P. O. Box 1500 Huntsville, AL 35807-3801	1	Commander U.S. Army ARDEC ATTN: SMCAR-MSI Dover, NJ 07801-5001
1	Chairman DOD Explosives Safety Board Room 856-C Hoffman Bldg. 1 2461 Eisenhower Avenue Alexandria, VA 22331-9999	1	Commander U.S. Army ARDEC ATTN: SMCAR-TDC Dover, NJ 07801-5001
1	Commander US Army Materiel Command ATTN: AMCPM-GCM-WF 5001 Eisenhower Avenue Alexandria, VA 22333-5001	4	Commander US Army Armament Munitions and Chemical Command ATTN: AMSMC-IMP-L Rock Island, IL 61299-7300
1	Commander US Army Materiel Command ATTN: AMCDRA-ST 5001 Eisenhower Avenue Alexandria, VA 22333-5001	1	HQDA DAMA-ART-M Washington, DC 20310-2500
1	Commander US Army Materiel Command ATTN: AMCDE-DW 5001 Eisenhower Avenue Alexandria, VA 22333-5001	1	Commander US Army AMCCOM ARDEC CCAC ATTN: SMCAR-CCB-TL Benet Weapons Laboratory Watervliet, NY 12189-4050

DISTRIBUTION LIST

<u>No. of Copies</u>	<u>Organization</u>	<u>No. of Copies</u>	<u>Organization</u>
3	Commander US Army ARDEC ATTN: SMCAR-MSI SMCAR-TDC SMCAR-LC LTC N. Barron Dover, NJ 07801-5001	1	Commander US Army Communications - Electronics Command ATTN: AMSEL-ED Fort Monmouth, NJ 07703-5301
7	Commander US Army ARDEC ATTN: SMCAR-LCA A. Beardell D. Downs S. Einstein S. Westley S. Bernstein C. Roller J. Rutkowski Dover, NJ 07801-5001	1	Commander CECOM R&D Technical Library ATTN: AMSEL-M-L (Report Section) B.2700 Fort Monmouth, NJ 07703-5000
3	Commander US Army ARDEC ATTN: SMCAR-LCB-I D. Spring SMCAR-LCE SMCAR-LCM-E S. Kaplowitz Dover, NJ 07801-5001	1	Commander US Army Harry Diamond Lab. ATTN: DELHD-TA-L 2800 Powder Mill Road Adelphi, MD 20783-1145
4	Commander US Army ARDEC ATTN: SMCAR-LCS SMCAR-LCU-CT E. Barrieres R. Davitt SMCAR-LCU-CV C. Mandala Dover, NJ 07801-5001	1	Commander US Army Missile and Space Intelligence Center ATTN: AIAMS-YDL Redstone Arsenal, AL 35898-5500
3	Commander US Army ARDEC ATTN: SMCAR-LCW-A M. Salsbury SMCAR-SCA L. Stiefel B. Brodman Dover, NJ 07801-5001	1	Commander US Army Missile Command Research, Development, and Engineering Center ATTN: AMSMI-RD Redstone Arsenal, AL 35898-5245
1	Commander US Army Aviation Systems Command ATTN: AMSA V-ES 4300 Goodfellow Blvd. St. Louis, MO 63120-1798	1	Commandant US Army Aviation School ATTN: Aviation Agency Fort Rucker, AL 36360
1	Director US Army Aviation Research and Technology Activity Ames Research Center Moffett Field, CA 94035-1099	1	Commander US Army Tank Automotive Command ATTN: AMSTA-TSL Warren, MI 48397-5000
		1	Commander US Army Tank Automotive Command ATTN: AMSTA-CG Warren, MI 48397-5000
		1	Project Manager Improved TOW Vehicle ATTN: AMCPM-ITV US Army Tank Automotive Command Warren, MI 48397-5000

DISTRIBUTION LIST

<u>No. of Copies</u>	<u>Organization</u>	<u>No. of Copies</u>	<u>Organization</u>
2	Program Manager M1 Abrams Tank System ATTN: AMCPM-GMC-SA, T. Dean Warren, MI 48092-2498	1	Commandant US Army Infantry School ATTN: ATSH-CD-CS-OR Fort Benning, GA 31905-5400
1	Project Manager Fighting Vehicle Systems ATTN: AMCPM-FVS Warren, MI 48092-2498	1	Commandant US Army Command and General Staff College Fort Leavenworth, KS 66027
1	President US Army Armor & Engineer Board ATTN: ATZK-AD-S Fort Knox, KY 40121-5200	1	Commandant US Army Special Warfare School ATTN: Rev & Tng Lit Div Fort Bragg, NC 28307
1	Project Manager M-60 Tank Development ATTN: AMCPM-M60TD Warren, MI 48092-2498	3	Commander Radford Army Ammunition Plant ATTN: SMCRA-QA/HI LIB Radford, VA 24141-0298
1	Director US Army TRADOC Systems Analysis Activity ATTN: ATOR-TSL White Sands Missile Range, NM 88002	1	Commander US Army Foreign Science & Technology Center ATTN: AMXST-MC-3 220 Seventh Street, NE Charlottesville, VA 22901-5396
1	Commander US Army Training & Doctrine Command ATTN: ATCD-MA/ MAJ Williams Fort Monroe, VA 23651	2	Commandant US Army Field Artillery Center & School ATTN: ATSE-CO-MW, B. Willis Ft. Sill, OK 73503-5600
2	Commander US Army Materials and Mechanics Research Center ATTN: AMXMR-ATL Tech Library Watertown, MA 02172	1	Commander US Army Development and Employment Agency ATTN: MODE-ORO Fort Lewis, WA 98433-5099
1	Commander US Army Research Office ATTN: Tech Library P. O. Box 12211 Research Triangle Park, NC 27709-2211	1	Office of Naval Research ATTN: Code 473, R. S. Miller 800 N. Quincy Street Arlington, VA 22217-9999
1	Commander US Army Belvoir Research and Development Center ATTN: STRBE-WC Fort Belvoir, VA 22060-5606	3	Commandant US Army Armor School ATTN: ATZK-CD-MS M. Falkovitch Armor Agency Fort Knox, KY 40121-5215
1	Commander US Army Logistics Mgmt Ctr Defense Logistics Studies Fort Lee, VA 23801	2	Commander Naval Sea Systems Command ATTN: SEA 62R SEA 64 Washington, DC 20362-5101

DISTRIBUTION LIST

<u>No. of Copies</u>	<u>Organization</u>	<u>No. of Copies</u>	<u>Organization</u>
1	Commander Naval Air Systems Command ATTN: AIR-954-Tech Lib Washington, DC 20360	1	Program Manager AFOSR Directorate of Aerospace Sciences ATTN: L. H. Caveny Bolling AFB, DC 20332-0001
1	Assistant Secretary of the Navy (R, E, and S) ATTN: R. Reichenbach Room 5E787 Pentagon Bldg. Washington, DC 20350	6	Commander Naval Ordnance Station ATTN: P. L. Stang L. Torreyson T. C. Smith D. Brooks W. Vienna Tech Library Indian Head, MD 20640-5000
1	Naval Research Lab Tech Library Washington, DC 20375	1	AFSC/SDOA Andrews AFB, MD 20334
5	Commander Naval Surface Weapons Center ATTN: Code G33, J. L. East W. Burrell J. Johndrow Code G23, D. McClure Code DX-21 Tech Lib Dahlgren, VA 22448-5000	3	AFRPL/DY, Stop 24 ATTN: J. Levine/DYCR R. Corley/DYC D. Williams/DYCC Edwards AFB, CA 93523-5000
2	Comander US Naval Surface Weapons Center ATTN: J. P. Consaga C. Gotzmer Indian Head, MD 20640-5000	1	AF Astronautics Laboratory AFAL/TSTL (Technical Library) Edwards AFB, CA 93523-5000
4	Commander Naval Surface Weapons Center ATTN: S. Jacobs/Code 240 Code 730 K. Kim/Code R-13 R. Bernecker Silver Spring, MD 20903-5000	1	AFATL/DLYV Eglin AFB, FL 32542-5000
2	Commanding Officer Naval Underwater Systems Center Energy Conversion Dept. ATTN: CODE 5B331, R. S. Lazar Tech Lib Newport, RI 02840	1	AFATL/DLXP Eglin AFB, FL 32542-5000
5	Commander Naval Weapons Center ATTN: Code 388, R. L. Derr C. F. Price T. Boggs T. Parr Info. Sci. Div. China Lake, CA 93555-6001	1	AFATL/DLJE Eglin AFB, FL 32542-5000
2	Superintendent Naval Postgraduate School Dept. of Mech. Engineering Monterey, CA 93943-5100	1	AFATL/DOIL ATTN: (Tech Info Center) Eglin AFB, FL 32542-5438
		1	NASA/Lyndon B. Johnson Space Center ATTN: NHS-22, Library Section Houston, TX 77054
		1	AFELM, The Rand Corporation ATTN: Library D 1700 Main Street Santa Monica CA 90401-3297
		2	AAI Corporation ATTN: J. Hebert J. Frankle D. Cleveland P. O. Box 6767 Baltimore, MD 21204

DISTRIBUTION LIST

<u>No. of Copies</u>	<u>Organization</u>	<u>No. of Copies</u>	<u>Organization</u>
1	Aerojet Ordnance Company ATTN: D. Thatcher 2521 Michelle Drive Tustin, CA 92680-7014	1	Lawrence Livermore National Laboratory ATTN: L-324/M. Constantino P. O. Box 808 Livermore, CA 94550-0622
1	Aerojet Solid Propulsion Co. ATTN: P. Micheli Sacramento, CA 95813	1	Olin Corporation Badger Army Ammunition Plant ATTN: R. J. Thiede Baraboo, WI 53913
1	Atlantic Research Corporation ATTN: M. K. King 5390 Cheorokee Avenue Alexandria, VA 22312-2302	1	Olin Corporation Smokeless Powder Operations ATTN: D. C. Mann P.O. Box 222 St. Marks, FL 32355-0222
1	AVCO Everett Rsch Lab ATTN: D. Stickler 2385 Revere Beach Parkway Everett, MA 02149-5936	1	Paul Gough Associates, Inc. ATTN: P. S. Gough P. O. Box 1614, 1048 South St. Portsmouth, NH 03801-1614
2	Calspan Corporation ATTN: C. Morphy P. O. Box 400 Buffalo, NY 14225-0400	1	Physics International Company ATTN: Library H. Wayne Wampler 2700 Merced Street San Leandro, CA 94577-5602
1	General Electric Company Armament Systems Dept. ATTN: M. J. Bulman, Room 1311 128 Lakeside Avenue Burlington, VT 05401-4985	1	Princeton Combustion Research Lab., Inc. ATTN: M. Summerfield 475 US Highway One Monmouth Junction, NJ 08852-9650
1	IITRI ATTN: M. J. Klein 10 W. 35th Street Chicago, IL 60616-3799	2	Rockwell International Rocketdyne Division ATTN: BA08 J. E. Flanagan J. Gray 6633 Canoga Avenue Canoga Park, CA 91303-2703
1	Hercules Inc. Allegheny Ballistics Laboratory ATTN: R. B. Miller P. O. Box 210 Cumberland, MD 21501-0210	1	Science Applications, Inc. ATTN: R. B. Edelman 23146 Cumorah Crest Drive Woodland Hills, CA 91364-3710
1	Hercules, Inc. Bacchus Works ATTN: K. P. McCarty P. O. Box 98 Magna, UT 84044-0098	3	Thiokol Corporation Huntsville Division ATTN: D. Flanigan R. Glick Tech Library Huntsville, AL 35807
1	Hercules, Inc. Radford Army Ammunition Plant ATTN: J. Pierce Radford, VA 24141-0299	2	Thiokol Corporation Elkton Division ATTN: R. Biddle Tech Lib. P. O. Box 241 Elkton, MD 21921-0241
1	Lawrence Livermore National Laboratory ATTN: L-355, A. Buckingham M. Finger P. O. Box 808 Livermore, CA 94550-0622		

DISTRIBUTION LIST

<u>No. of Copies</u>	<u>Organization</u>	<u>No. of Copies</u>	<u>Organization</u>
1	Veritay Technology, Inc. ATTN: E. Fisher 4845 Millersport Hwy. P. O. Box 305 East Amherst, NY 14051-0305	3	Georgia Institute of Tech School of Aerospace Eng. ATTN: B. T. Zinn E. Price W. C. Strahle Atlanta, GA 30332
1	Universal Propulsion Company ATTN: H. J. McSpadden Black Canyon Stage 1 Box 1140 Phoenix, AZ 85029	1	Institute of Gas Technology ATTN: D. Gidaspow 3424 S. State Street Chicago, IL 60616-3896
1	Battelle Memorial Institute ATTN: Tech Library 505 King Avenue Columbus, OH 43201-2693	1	Johns Hopkins University Applied Physics Laboratory Chemical Propulsion Information Agency ATTN: T. Christian Johns Hopkins Road Laurel, MD 20707-0690
1	Brigham Young University Dept. of Chemical Engineering ATTN: M. Beckstead Provo, UT 84601	1	Massachusetts Institute of Technology Dept of Mechanical Engineering ATTN: T. Toong 77 Massachusetts Avenue Cambridge, MA 02139-4307
1	California Institute of Tech 204 Karman Lab Main Stop 301-46 ATTN: F. E. C. Culick 1201 E. California Street Pasadena, CA 91109	1	G. M. Faeth Pennsylvania State University Applied Research Laboratory University Park, PA 16802-7501
1	California Institute of Tech Jet Propulsion Laboratory ATTN: L. D. Strand 4800 Oak Grove Drive Pasadena, CA 91109-8099	1	Pennsylvania State University Dept. of Mech. Engineering ATTN: K. Kuo University Park, PA 16802-7501
1	University of Illinois Dept of Mech/Indust Engr ATTN: H. Krier 144 MEB; 1206 N. Green St. Urbana, IL 61801-2978	1	Purdue University School of Mechanical Engineering ATTN: J. R. Osborn TSPC Chaffee Hall West Lafayette, IN 47907-1199
1	University of Massachusetts Dept. of Mech. Engineering ATTN: K. Jakus Amherst, MA 01002-0014	1	SRI International Propulsion Sciences Division ATTN: Tech Library 333 Ravenswood Avenue Menlo Park, CA 94025-3493
1	University of Minnesota Dept. of Mech. Engineering ATTN: E. Fletcher Minneapolis, MN 55414-3368	1	Rensselaer Polytechnic Inst. Department of Mathematics Troy, NY 12181
1	Case Western Reserve University Division of Aerospace Sciences ATTN: J. Tien Cleveland, OH 44135		

DISTRIBUTION LIST

<u>No. of Copies</u>	<u>Organization</u>	<u>No. of Copies</u>	<u>Organization</u>
2	Director Los Alamos Scientific Lab ATTN: T3, D. Butler M. Division, B. Craig P. O. Box 1663 Los Alamos, NM 87544		
1	Stevens Institute of Technology Davidson Laboratory ATTN: R. McAlevy, III Castle Point Station Hoboken, NJ 07030-5907		
1	Rutgers University Dept. of Mechanical and Aerospace Engineering ATTN: S. Temkin University Heights Campus New Brunswick, NJ 08903		
1	University of Southern California Mechanical Engineering Dept. ATTN: OHE200, M. Gerstein Los Angeles, CA 90089-5199		
2	University of Utah Dept. of Chemical Engineering ATTN: A. Baer G. Flandro Salt Lake City, UT 84112-1194		
1	Washington State University Dept. of Mech. Engineering ATTN: C. T. Crowe Pullman, WA 99163-5201		

Aberdeen Proving Ground

Dir, USAMSAA
ATTN: AMXSY-D
AMXSY-MP, H. Cohen

Cdr, USATECOM
ATTN: AMSTE-SI-F
AMSTE-CM-F, L. Nealley

Cdr, CSTA
ATTN: STECS-AS-H, R. Hendricksen

Cdr, CRDC, AMCCOM
ATTN: SMCCR-RSP-A
SMCCR-MU
SMCCR-**MSI**

USER EVALUATION SHEET/CHANGE OF ADDRESS

This Laboratory undertakes a continuing effort to improve the quality of the reports it publishes. Your comments/answers to the items/questions below will aid us in our efforts.

1. BRL Report Number _____ Date of Report _____

2. Date Report Received _____

3. Does this report satisfy a need? (Comment on purpose, related project, or other area of interest for which the report will be used.) _____

4. How specifically, is the report being used? (Information source, design data, procedure, source of ideas, etc.) _____

5. Has the information in this report led to any quantitative savings as far as man-hours or dollars saved, operating costs avoided or efficiencies achieved, etc? If so, please elaborate. _____

6. General Comments. What do you think should be changed to improve future reports? (Indicate changes to organization, technical content, format, etc.) _____

CURRENT ADDRESS
Name _____
Organization _____
Address _____
City, State, Zip _____

7. If indicating a Change of Address or Address Correction, please provide the New or Correct Address in Block 6 above and the Old or Incorrect address below.

OLD ADDRESS
Name _____
Organization _____
Address _____
City, State, Zip _____

(Remove this sheet, fold as indicated, staple or tape closed, and mail.)

FOLD HERE

Director
U.S. Army Ballistic Research Laboratory
ATTN: SLCBR-DD-T
Aberdeen Proving Ground, MD 21005-5066



NO POSTAGE
NECESSARY
IF MAILED
IN THE
UNITED STATES

OFFICIAL BUSINESS
PENALTY FOR PRIVATE USE, \$300

BUSINESS REPLY MAIL
FIRST CLASS PERMIT NO 12062 WASHINGTON, DC
POSTAGE WILL BE PAID BY DEPARTMENT OF THE ARMY

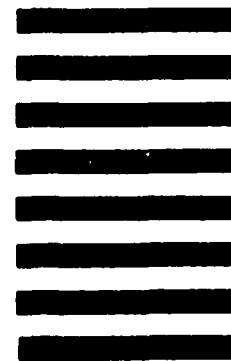

Director
U.S. Army Ballistic Research Laboratory
ATTN: SLCBR-DD-T
Aberdeen Proving Ground, MD 21005-9989

FOLD HERE