

AD-A201 419

Research Product 88-17

Design and Functional Specifications
for the Simulation of the Commander's
Independent Thermal Viewer (CITV)

ARI Field Unit at Fort Knox, Kentucky
Training Research Laboratory

July 1988

DTIC
ELECTE
OCT 26 1988
S E D

88 1025 038



U. S. Army Research Institute for the Behavioral and Social Sciences

U. S. ARMY RESEARCH INSTITUTE FOR THE BEHAVIORAL AND SOCIAL SCIENCES

A Field Operating Agency under the Jurisdiction of the
Deputy Chief of Staff for Personnel

EDGAR M. JOHNSON
Technical Director

WM. DARRYL HENDERSON
COL, IN
Commanding

Technical review by

Richard Koffinke
Ronald E. Kraemer

Accession For	
NTIS GRA&I	<input checked="" type="checkbox"/>
DTIC TAB	<input type="checkbox"/>
Unannounced	<input type="checkbox"/>
Justification	
By _____	
Distribution/	
Availability Codes	
Dist	Avail and/or Special
A-1	

NOTICES

FINAL DISPOSITION: This Research Product may be destroyed when it is no longer needed. Please do not return it to the U.S. Army Research Institute for the Behavioral and Social Sciences.

NOTE: This Research Product is not to be construed as an official Department of the Army document in its present form.



REPORT DOCUMENTATION PAGE				Form Approved OMB No. 0704-0188	
1a. REPORT SECURITY CLASSIFICATION Unclassified		1b. RESTRICTIVE MARKINGS ---			
2a. SECURITY CLASSIFICATION AUTHORITY ---		3. DISTRIBUTION / AVAILABILITY OF REPORT Approved for public release; distribution unlimited.			
2b. DECLASSIFICATION / DOWNGRADING SCHEDULE ---					
4. PERFORMING ORGANIZATION REPORT NUMBER(S) ---		5. MONITORING ORGANIZATION REPORT NUMBER(S) ARI Research Product 88-17			
6a. NAME OF PERFORMING ORGANIZATION ARI Field Unit at Fort Knox		6b. OFFICE SYMBOL (if applicable) PERI-1K	7a. NAME OF MONITORING ORGANIZATION U.S. Army Research Institute for the Behavioral and Social Sciences		
6c. ADDRESS (City, State, and ZIP Code) Fort Knox, KY 40121-5620		7b. ADDRESS (City, State, and ZIP Code) 5001 Eisenhower Avenue Alexandria, VA 22333-5600			
8a. NAME OF FUNDING / SPONSORING ORGANIZATION ---		8b. OFFICE SYMBOL (if applicable) ---	9. PROCUREMENT INSTRUMENT IDENTIFICATION NUMBER ---		
8c. ADDRESS (City, State, and ZIP Code) ---		10. SOURCE OF FUNDING NUMBERS			
		PROGRAM ELEMENT NO. A790	PROJECT NO. 2Q162 717A790	TASK NO. 3.5.1	WORK UNIT ACCESSION NO. 3.5.1.H.1
11. TITLE (Include Security Classification) Design and Functional Specifications for the Simulation of the Commander's Independent Thermal Viewer (CITV)					
12. PERSONAL AUTHOR(S) Kathleen A. Quinkert					
13a. TYPE OF REPORT Final		13b. TIME COVERED FROM 5/87 TO 5/88		14. DATE OF REPORT (Year, Month, Day) 1988, July	15. PAGE COUNT 41
16. SUPPLEMENTARY NOTATION ---					
17. COSATI CODES			18. SUBJECT TERMS (Continue on reverse if necessary and identify by block number)		
FIELD	GROUP	SUB-GROUP	M1 tank	Soldier-machine interface (SMI)	MANPRINT
			CITV	Target acquisition	M1 Block II
19. ABSTRACT (Continue on reverse if necessary and identify by block number) The Commander's Independent Thermal Viewer (CITV) is a high-priority component of the Block II preplanned product improvements (PPI) for the M1 tank. Army developers have suggested that this addition will enhance the fighting ability of the tank by providing increases of up to 40% in target acquisition. This predicted enhancement was questioned, however, when several soldier-machine-interface (SMI) issues were raised. To address these SMI issues early in the acquisition cycle, research using simulation was proposed. This document was developed to provide Army contractors with design guidelines and function specifications of a generic CITV to be used in simulation. Contractors associated with the Development Simulation Networking (SIMNET-D) and the Unit Conduct of Fire Trainer (UCOFT) are considered the prime users of the document. <i>Keywords: Man machine interface, Target acquisition, Tanks (Combat Vehicles), Gun sights. (SDW)</i>					
20. DISTRIBUTION / AVAILABILITY OF ABSTRACT <input checked="" type="checkbox"/> UNCLASSIFIED/UNLIMITED <input type="checkbox"/> SAME AS RPT <input type="checkbox"/> DTIC USERS			21. ABSTRACT SECURITY CLASSIFICATION Unclassified		
22a. NAME OF RESPONSIBLE INDIVIDUAL Kathleen A. Quinkert			22b. TELEPHONE (Include Area Code) 502-624-6928	22c. OFFICE SYMBOL PERI-1K	

Design and Functional Specifications for the Simulation of the Commander's Independent Thermal Viewer (CITV)

Kathleen A. Quinkert

ARI Field Unit at Fort Knox, Kentucky
Donald F. Haggard, Chief

Training Research Laboratory
Jack H. Hiller, Director

U.S. ARMY RESEARCH INSTITUTE FOR THE BEHAVIORAL AND SOCIAL SCIENCES
5001 Eisenhower Avenue, Alexandria, Virginia 22333-5600

Office, Deputy Chief of Staff for Personnel
Department of the Army

July 1988

Army Project Number
2Q162717A790

Human Performance and Simulation

Approved for public release; distribution unlimited.

Preceding Page Blank

FOREWORD

The U.S. Army Research Institute's Fort Knox Field Unit conducts research in the area of training requirements for new main battle tanks under Science and Technology Task 3.5.1. As a part of this research, it is necessary to develop simulation tools for the assessment of soldier-in-the-loop performance. This document provides functional guidelines and specifications for the design of such a tool. Specifically, these guidelines describe how the Commander's Independent Thermal Viewer (CITV), an M1 preplanned product improvement, should be implemented in the Developmental Simulation Networking (SIMNET-D), the U.S. Army's latest simulation technology test bed. Research efforts conducted by ARI at Fort Knox and other agencies at the U.S. Army Armor Center (USAARMC), will capitalize on this simulation to address Manpower and Personnel Integration (MANPRINT), doctrinal, and force structure issues.

Information contained herein has been briefed to the following Army Agencies: Training and Doctrine Command (TRADOC) System Manager--Tank, Directorate of Combat Developments--USAARMC, Weapons Department--USAARMC, Project Manager--M1A1, and Project Manager--Training Devices. Copies of this report have also been provided to contractors responsible for modifications to SIMNET-D and the Unit Conduct of Fire Trainer (UCOFT).

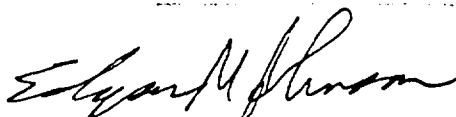

EDGAR M. JOHNSON
Technical Director

DESIGN AND FUNCTIONAL SPECIFICATIONS FOR THE SIMULATION OF THE
 COMMANDER'S INDEPENDENT THERMAL VIEWER (CITV)

CONTENTS

	Page
INTRODUCTION	1
CITV CONCEPT	2
MANPOWER AND PERSONNEL INTEGRATION (MANPRINT)	4
CITV IN SIMNET-D	6
CITV FUNCTIONAL CHARACTERISTICS AND CAPABILITIES	7
CITV Location	8
CITV-Soldier Interface	10
Operational Mode Switches	13
Function Switches	18
Commander's Control Handle	22
Additional CITV Capability for Simulation	24
DESCRIPTIVE SCENARIO USING CITV PROCEDURES	24
FUTURE ENHANCEMENTS FOR CITV SIMULATION	26
REFERENCES	28
APPENDIX A. EXECUTION PROCEDURES FOR AUTO SCAN CAPABILITY	A-1

LIST OF TABLES

Table A.1 Execution procedure for the complete auto scan capability	A-1
A.2 Execution procedure for the partial auto scan capability	A-3
A.3 Execution procedure for the partial auto scan capability	A-4
A.4 Execution procedure for the partial auto scan capability	A-5

LIST OF FIGURES

Figure 1.	CITV field of regard	3
2.	Internal view of the M1A1 depicting selected components of the M1A1 Block II Product Improvement Program . .	9
3.	CITV display	11
4.	CITV reticles	12
5.	Operational modes chart	14
6.	Proposed commander's control handle modified for CITV	23

DESIGN AND FUNCTIONAL SPECIFICATIONS FOR THE SIMULATION OF
THE COMMANDER'S INDEPENDENT THERMAL VIEWER (CITV)

INTRODUCTION

There is currently a need to evaluate the operational effectiveness of the Commander's Independent Thermal Viewer (CITV). Concurrently, there is a need to explore the potential soldier-related issues associated with the implementation of the CITV. Both the evaluation and exploration can be accomplished, to a large extent, through the use of simulation. The simulation, however, requires several simulated CITVs having highly flexible/modifiable capabilities which are networked on a common battlefield. This document provides functional guidelines and specifications for the design of such a simulation tool. Specifically, these guidelines describe how the CITV, an M1 preplanned product improvement (P³I), should be implemented in Simulation Networking-Developmental (SIMNET-D), the Army's latest simulation technology test bed. Additionally, the guidelines for the proposed design can be easily adapted for use by other Army agencies interested in the development of a CITV prototype for their own simulation devices.

Information about the CITV subsystems and their functions, a description of the proposed operational procedures, and limited technical data pertaining to the design of a CITV prototype will be presented. This information is based on documents and opinions from several sources. These sources include: (a) the Critical Item Development Specification for Commander's Independent Thermal Viewer System (Vol 1, 1985), (b) current hardware proposals or initial design concepts, (c) the M1/M1A1 integrating contractor's available research and development documents, (d) ARI's CITV research effort with the Tank Automotive Command (TACOM), and (e) Technical Manuals for the M1 and M1A1. The goal of this effort is to provide a developmental design of a generic CITV prototype. This prototype can then be iteratively reconfigured to allow the experimental evaluation of the CITV concept in addition to the exploration of potential soldier-machine-interface (SMI) issues.

The document is structured to include six separate, but CITV-related areas. These include: (a) a description of the CITV system, (b) a MANPRINT rationale for conducting proactive work on the CITV, (c) ARI's inclusion of CITV in SIMNET-D research, (d) a description of the functional characteristics and capabilities necessary for the CITV research, (e) a scenario describing the use of CITV procedures, and (f) a discussion of future enhancements for the CITV.

CITV CONCEPT

There are seven preplanned product improvements (P³I) for the M1 main battle tank which are commonly referred to as the Block II program. These enhancements include the Survivability Enhancement package, an Improved Commander's Weapon Station (ICWS), a CO² Laser Rangefinder (LRF), a Commander's Independent Thermal Viewer (CITV), a Driver's Thermal Viewer (DTV), a Battlefield Management System (BMS)¹ to include position location and heading (POS/NAV). To date testing and or component implementation has occurred for the survivability enhancement package, the ICWS, and the CO² LRF. Of the remaining components the CITV is currently the high priority component of the Block II program.

The CITV was originally proposed as an integral component of the BMS in the sense that the CITV would perform as the "eyes" of the management system. These eyes were seen to be profoundly important on the future battlefield where conditions of darkness and increasing degradation of battlefield visibility are predicted. (FM 100-5, 1982). However, due to funding constraints, the acquisition plan for the Block II P³I was fragmented resulting in a singular acquisition of the CITV. As a stand alone it serves as a real time thermal viewer utilizing forward looking infrared (FLIR) technology. The CITV system is designed to operate within the 8-14 micron range of the electromagnetic spectrum and is to be used by the commander in either closed or open hatch mode for target acquisition and surveillance.

The CITV provides the commander with a previously unavailable opportunity for independent surveillance and target acquisition. This opportunity allows the individual commander an expanded view of the battlefield that should enable him to move and shoot more efficiently and effectively. This independent surveillance and target acquisition, depicted in Figure 1, gives the commander at least a 270° unobstructed horizontal field of regard. In addition to the horizontal viewing, the CITV provides a vertical range of +20° to -12°. As originally conceived, the CITV was also an integral component of the M1A1 fire control system, providing a backup sighting capability for firing the main gun.

¹The Battlefield Management System (BMS) was the original terminology for the Block II program. Recently, the scope of this system has been downgraded and referred to as the Inter-vehicular Information System (IVIS). ARI's interest included the IVIS system but they also maintain interest in the objective system (BMS). Therefore, the acronym BMS is used in this document.

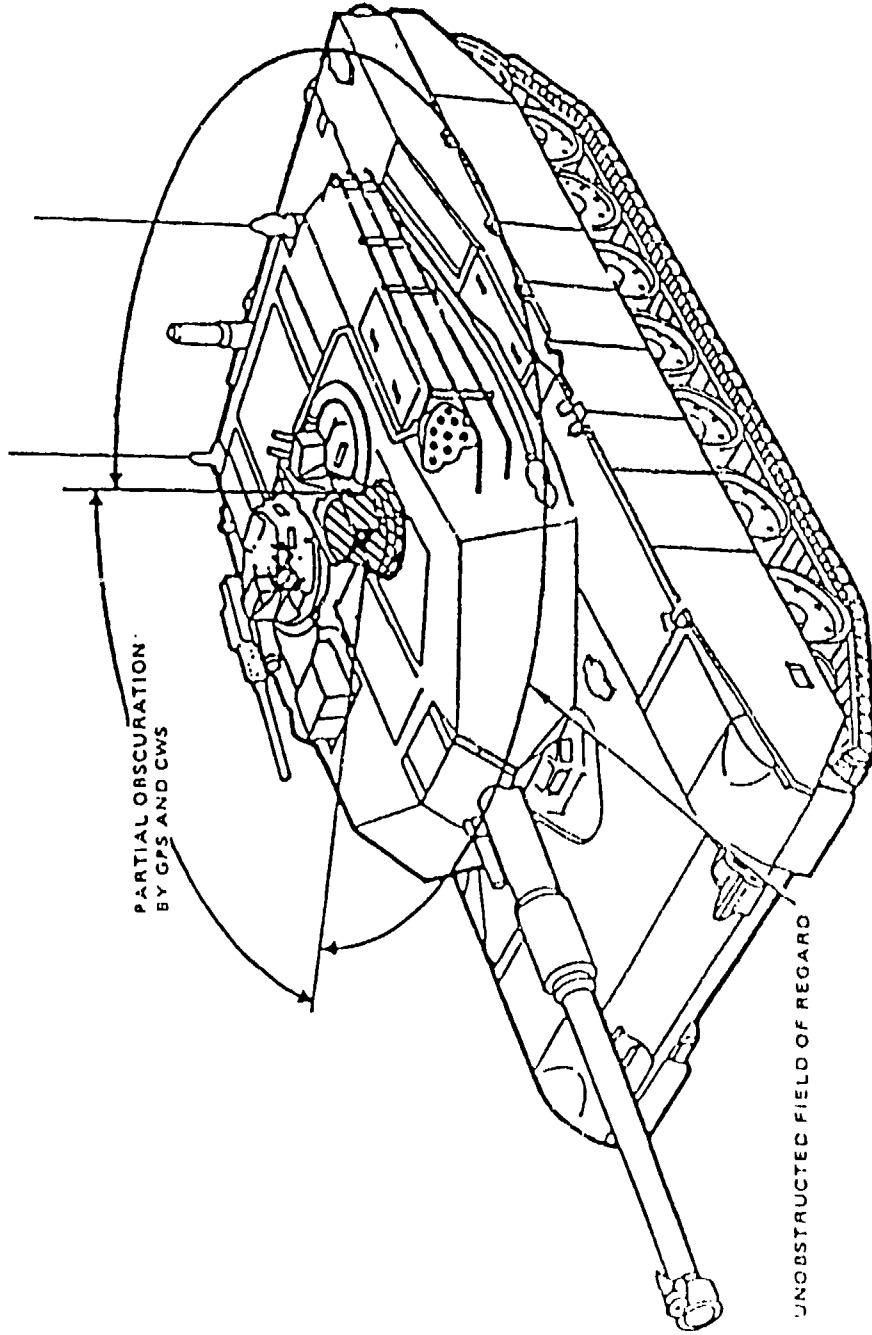

Figure 1. CITV field of regard.

The tank commander, equipped with a CITV, can independently search a predetermined sector, identify and hand off targets to the gunner by automatically slewing the gunner's primary sight reticle to the designated target location. As designed, the commander can then continue his independent search for additional targets while the gunner lays on the target, fires the main gun, and makes the damage assessment. When these actions are completed, the gunner could be slewed to a new target position by the commander or continue to search for targets in his assigned sector. This approach to independent search and automated target hand-off has been referred to as the Hunter-Killer concept.

The concept of the CITV is rather simple and definitely not novel. In fact, versions of the CITV are currently used in other main battle tanks, for example the Leopard 2. Basically, the CITV has three operational modes. The first allows the commander to independently survey the battlefield in either an automatic scan or a manual search mode. The second slaves the CITV to the gunner's primary sight to allow the commander to monitor or check the priority of a target. The third slaves the turret/main gun to the CITV line of sight to facilitate an increase in the frequency of target engagements. Despite its simplicity, implementation of the concept has the potential for high levels of complexity. There are several major issues that feed this complexity, all of which need to be addressed before a CITV design is accepted or adopted and the system is fielded. These issues include the design of the display, the controls with which the soldier must interact (i.e. SMI), and the possible inclusion of embedded training capabilities into the final CITV design. Additional issues, that should be addressed as soldier or user concern are problems associated with target hand-off and the adequacy of currently existing fire commands. These issues are exemplary of the concerns that fall into the domains of a new Army program called MANPRINT.

MANPOWER AND PERSONNEL INTEGRATION (MANPRINT)

Design trade-offs are a necessity in every new system acquisition; there are simply too many constraints that prevent the design and implementation of a perfect system. Ideally, one would hope that before these trade-offs are made the physical, psychological, and cognitive aspects of the operator and maintainer are considered. In the past, however, this has not been the rule. Final design decisions have been based solely on equipment performance without bothering to consider the soldiers who must operate and maintain the equipment. These types of equipment-based decisions have proven costly to the U.S. Army. These costs are reflected in the increased manpower and personnel requirements and, more importantly (in some instances) compromised the health and safety of the soldiers. Additionally,

there are added costs associated with labor intensive redesign efforts and required retrofits. These second efforts are necessary to correct "soldier unfriendly" or barely usable equipment, and ultimately cost the U.S. Army more over the life cycle of the system than the efforts necessary to have accurately accessed soldier impacts during the initial design stages.

In response to this continual predicament of barely usable equipment or costly retrofits, the Army has implemented a new approach referred to as MANPRINT (AR 602-2, 1986). MANPRINT is a comprehensive management and technical program designed to improve total system (soldier and equipment) performance by the continuous integration of Manpower, Personnel, Training, Human Factors Engineering, System Safety, and Health Hazard considerations throughout the life cycle of the system (Elton, 1986).

As a result of this new Army regulation, the combat, materiel, and training developers are now faced with ensuring, very early in the life cycle, that the system is designed for the soldier and not vice versa. Unfortunately, there are few tools currently available to support the MANPRINT process. Simulation models, once considered adequate for front-end analysis of the equipment, rarely make provisions for the consideration of the human element. Similarly, light, field tests which do include the human element, have proven very costly and perhaps too untimely for their results to affect the ultimate design of the system. This leaves the Army searching for viable technologies that can provide reliable soldier-in-the-loop involvement.

With the growth of simulation capabilities, such as Developmental Simulation Networking (SIMNET-D), the void in necessary MANPRINT tools and analyses may be partially filled. SIMNET-D, if used properly has the capability for examining issues in several of the MANPRINT domains. For example, personnel issues can be addressed by inserting soldiers of varying aptitude and ability levels into the soldier-in-the-loop evaluation process. Similarly, potential training problems can be identified from an evaluation of the time required to train soldiers to perform simulated tasks and from the type of errors that are committed (Quinkert & Black, 1987).

Simulation has the potential to be a useful MANPRINT tool. However, persons planning to implement a simulation-based research program should be reminded that concepts such as front-end developmental efforts, that drive the MANPRINT concept, are also important in the development of the simulation. In effect, if researchers are to gain worthwhile information, that is, if they are to obtain information that can then be used to actually affect the equipment design, considerable effort must be exerted to ensure that appropriate trade-offs are made in the simulation design decision process. Additionally, they must focus on the effects of selective fidelity on the results of their experiments

and make every effort to caveat their recommendations. These caveats should be presented in terms that reflect the differences in soldier performance that occur in a simulator and those that may be anticipated in the fielded, operational system.

CITV IN SIMNET-D

When the M1 Block II System MANPRINT Management Plan (SMMP) was compiled, several issues and questions about the CITV and its use were generated. These included the likelihood of disorientation (Hyman, 1986), motion sickness (Pickard & Boismier, 1986), information overload and system utility as determined by the SMI (Quinkert, 1987). Because of these issues, ARI at Ft. Knox initiated a research effort focused on the use of simulation to resolve some of the CITV MANPRINT issues. SIMNET-D was selected for the conduct of the initial CITV research for several reasons. First, it allows investigation of both individual and collective task performance in a realistic but simulated, battlefield. Second, SIMNET-D has a unique capability for data capture, and data analysis. Third, SIMNET-D has a data archiving capability that provides an audit trail to record potential designs and training obstacles associated with prototype designs. Fourth, SIMNET-D is based on a building block approach (modularity). This approach allows the researcher to use the results of prior research to reconfigure the design or modify the training plans for exploratory research at more or less complex levels. For example, the hardware and software used in an individual crew research effort can be reconfigured with relative ease and expanded to facilitate research at the platoon or company level and vice versa. While SIMNET-D should be able to resolve many of the issues, it may not be the best means available to address questions regarding the gunnery applications associated with the CITV. Those issues may require higher fidelity gunnery simulators such as the Unit Conduct of Fire Trainer (U-COFT).

To resolve CITV MANPRINT issues in SIMNET-D, the simulation must include a realistic representation of the system's physical characteristics as well as its performance. These fidelity criteria include, but are not limited to, realistic image presentation, especially field of view, elevation, viewing distances and resolution levels, switch/handle configurations and work space constraints. One critical standard against which fidelity decisions should be made is whether the situation and cues presented by the simulation elicit soldier responses in a manner similar to that in an operational or field situation. Other issues that should be considered include:

- The capabilities that reside in the simulation for selectively degrading the functions of these systems so that the need for redundancies and for specifying tasks to be trained in degraded modes can be examined.

- The effects of intervening variables on soldier responses and, where simulation will allow, how these variables can be determined and controlled.
- The features or characteristics of the proposed system that should be fully functional in the simulation and the determination of which characteristics should not (i.e, selective fidelity).
- The determination of which characteristics are critical to the evaluation and which should be eliminated from a cost-benefit standpoint.

In addition to addressing these MANPRINT issues, this research should also serve as a focal point for answering questions pertaining to the effectiveness of the CITV system for battlefield operations and the necessary institutional and unit training changes associated with the system implementation.

CITV FUNCTIONAL CHARACTERISTICS AND CAPABILITIES

The information provided herein is a combination of several design proposals. These proposals were integrated within the parameters established by the requirements found in the Critical Item Development Specification for the Commander's Independent Thermal Viewer System (CIDS). The resulting generic CITV is based on the U.S. Army Armor Center's requirements and desired capabilities. It does not, however, reflect any specific system proposed by any U.S. Army agency or any particular contractor.

Not all of these characteristics and functions will be required in the CITV simulation research. Selective fidelity decisions have already been made based on the guidelines detailed earlier in this document, as well as the consideration of the simulation capability and opinions of Subject Matter Experts (SMEs). The decisions made pertaining to the presence and operational capability of switches and controls are noted at the end of each CITV switch/control description. Additionally, the generic CITV to be used for the simulation was designed with the following assumptions:

- 270° Field of Regard
- Capability to fire the main gun from the CITV
- Limited automatic target recognition (ATR) capability
- Limited target stacking capability

- Limited target stacking capability
- No target prioritization capability

There are inherent differences between the actual CITV procurement for the U.S. Army and the procurement of the simulation CITV for research that the reader must be fully cognizant. The proposed generic CITV is not a fully developed piece of hardware, designed in accordance with military specifications. Rather, it is a representation of selective CITV capabilities, both required and desired for inclusion in the simulation. One area where this difference is immediately noted is in the switchology used for the simulation. The design of the control panel required in the CIDS document is completely comprised of knobs and dials built in accordance with the current military specifications. The display to be used in the CITV simulation research, however, will emulate the use of newer technology designated as microswitches (also referred to as multifunction switches).

Microswitch technology is a new generation of switchology that allows the user to control several functions with fewer controls. For example, if you have a switch that is assigned the label of brightness, one way to program this switch for multifunctions would be to push the switch once for the control of reticle brightness and a second push to control the symbology brightness. A major advantage provided by this type of switchology is obvious. There is the capability for more functions in less space on the display panel. There is, however, an additional advantage in that the user is always aware of the function in use. That is, when the function changes, so also does the name (designate) presented on the switch.

In this CITV simulation research, the multifunction switches will be represented through the use of touch screen technology. This approach roughly emulates the motor behavior used with the multifunction switches with respect to accuracy and time. In addition, it facilitates the capability of the designer to quickly reconfigure the control panel, through changes in software, for a determination of the best SMI.

CITV Location

The proposed location of the CITV Display Unit is the area directly in front of the commander and to the right of the commander's gunner's primary sight extension. A visual depiction of a proposed CITV designed within the parameters of the available turret space is shown in Figure 2.

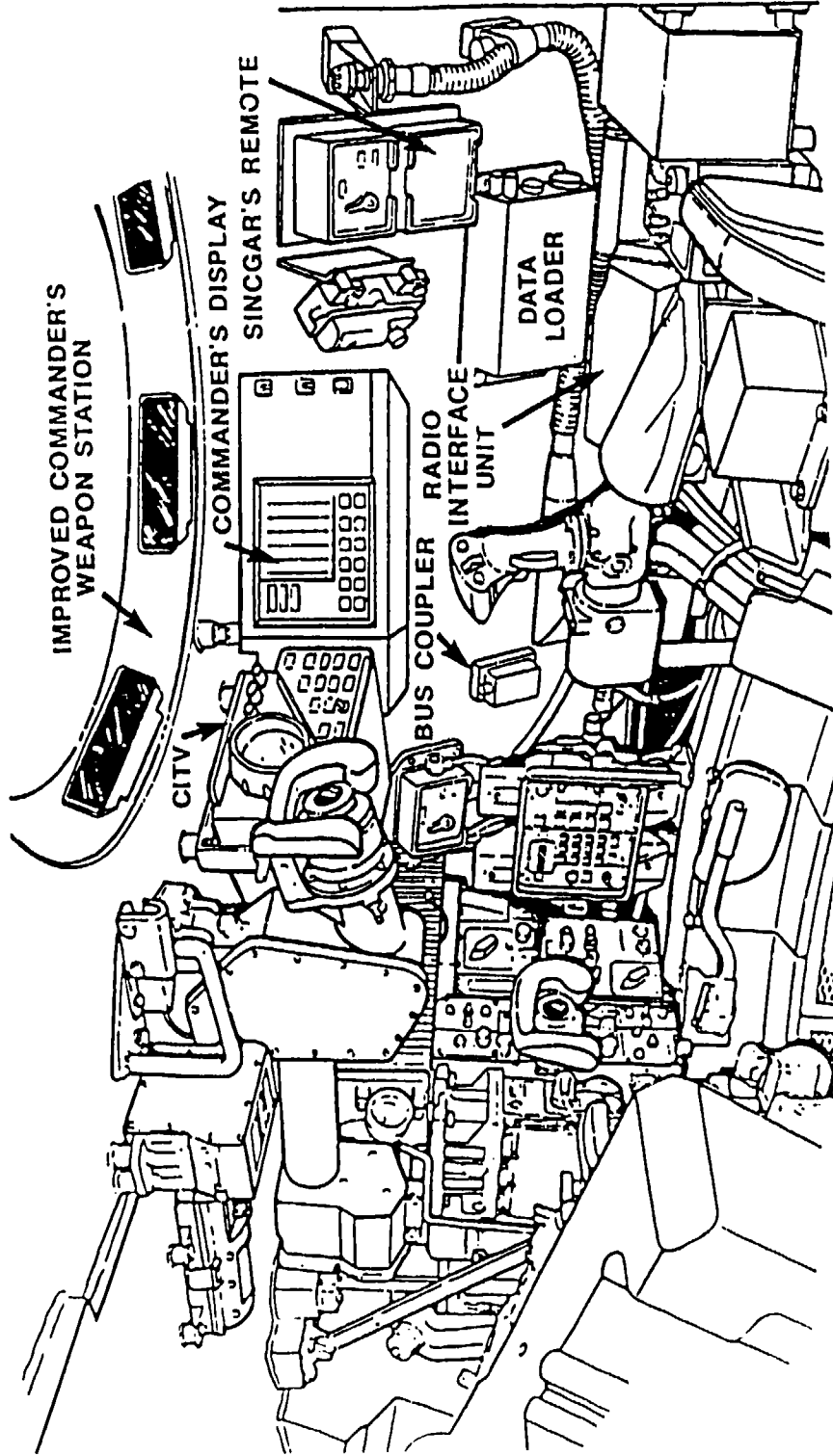

Figure 2. Internal view of the MIAI depicting selected components of the MIAI Block II Product Improvement Program.

CITV-Soldier Interface

CITV Display Unit

The CITV Display Unit consists of two major components: the CITV display face, and the CITV control panel.

CITV Display Face. The display face proposed for the CITV is shown in Figure 3. The display face is circular and approximately 6 inches in diameter. In addition to the battlefield imagery, there are several components that collectively comprise the functions provided on the display face. These include the reticles, the orientation indicator, and main gun information. This main gun information is identical to that displayed in the gunner's primary sight extension. These include, but are not limited to, the fault indicator, range information, and laser return data (see TM 9-2350-255-10).

In the CIDS document there are three reticles that pertain to the use of the CITV: the wide field of view (WFOV) reticle, the narrow field of view (NFOV) reticle, and the emergency battle-range reticle. The WFOV, in accordance with the CIDS document, should represent, at a minimum, a 7.5 degrees vertical by 10.0 degrees horizontal window. It is depicted in Figure 4a as a frame or outline that represents the boundaries of the NFOV. The NFOV should represent, at a minimum a 2.5 degrees vertical by 3.3 degrees horizontal window. It is depicted in Figure 4b. Both reticles should be identical to the already existing reticles in the gunner's primary sight extension used by the tank commander. These reticles will be presented on the display face only after they are selected with the appropriate function controls. For purposes of this research, the control that the tank commander uses to select WFOV and NFOV is a fingertip operated slide control located on the bottom of the display panel (Figure 3). The emergency battlerange reticle described in the CIDS document is ballistic in nature. It has been suggested that this reticle be displayed as a stadiametric reticle that requires the tank commander to fit the threat turret into the veins of the reticle. The commander can then determine range to the target by reading the appropriate range line provided in the display. For research purposes, the emergency battle range reticle will not be functional and no space claim (switch/button) will be allocated for its control.

The orientation indicator proposed to depict the relationship of the CITV, turret, and hull positions is presented in Figure 3. At any given time, the use of the indicator will allow the commander to determine: (a) the CITV to turret/main gun relationship; (b) the CITV to chassis relationship; and (c) the turret/main gun to chassis relationship. Because orientation is considered a key MANPRINT issue for the CITV, the orientation icon design will be flexible to allow exploration of maximum

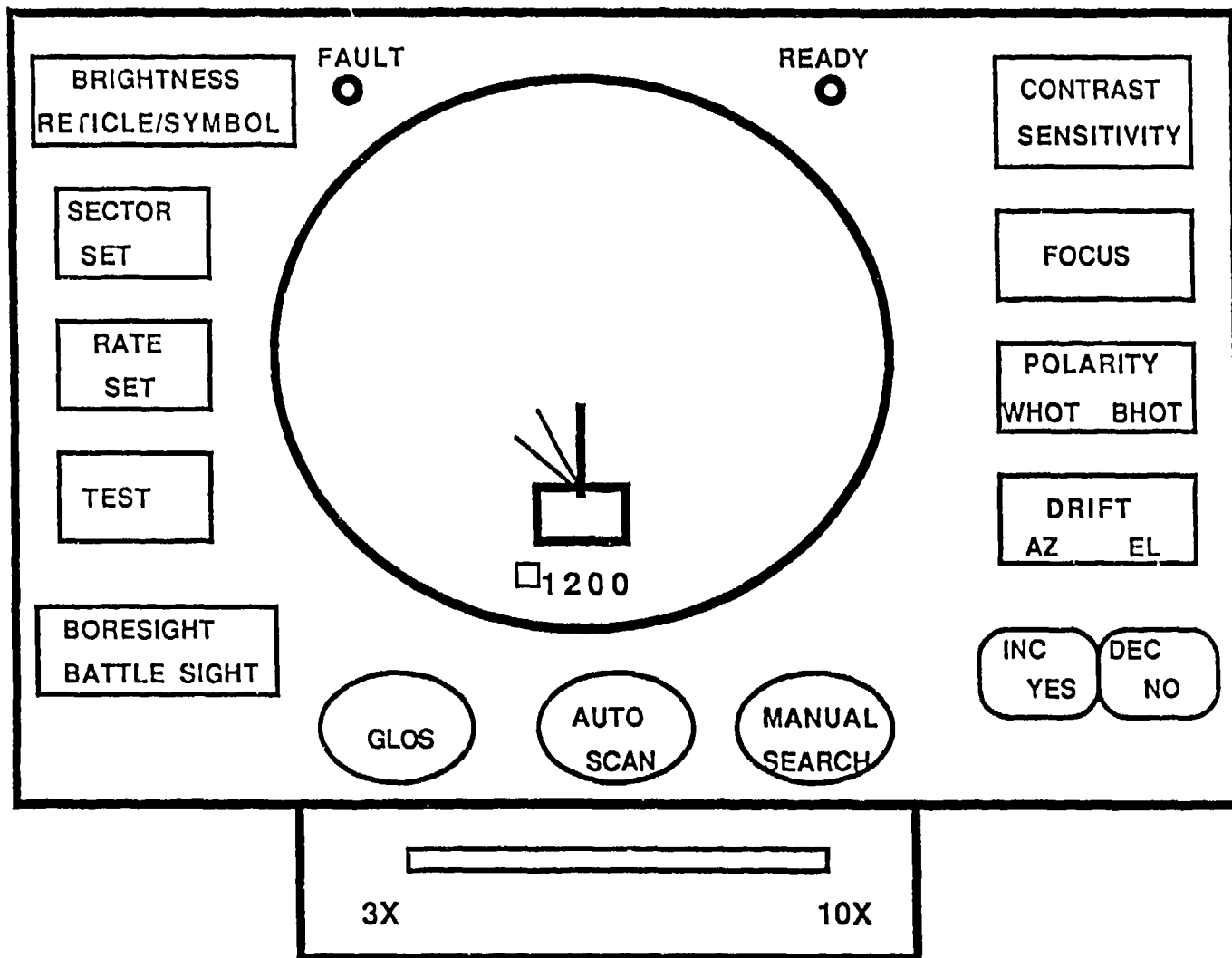

Figure 3. CITV display.

Figure 4. CITV reticles.

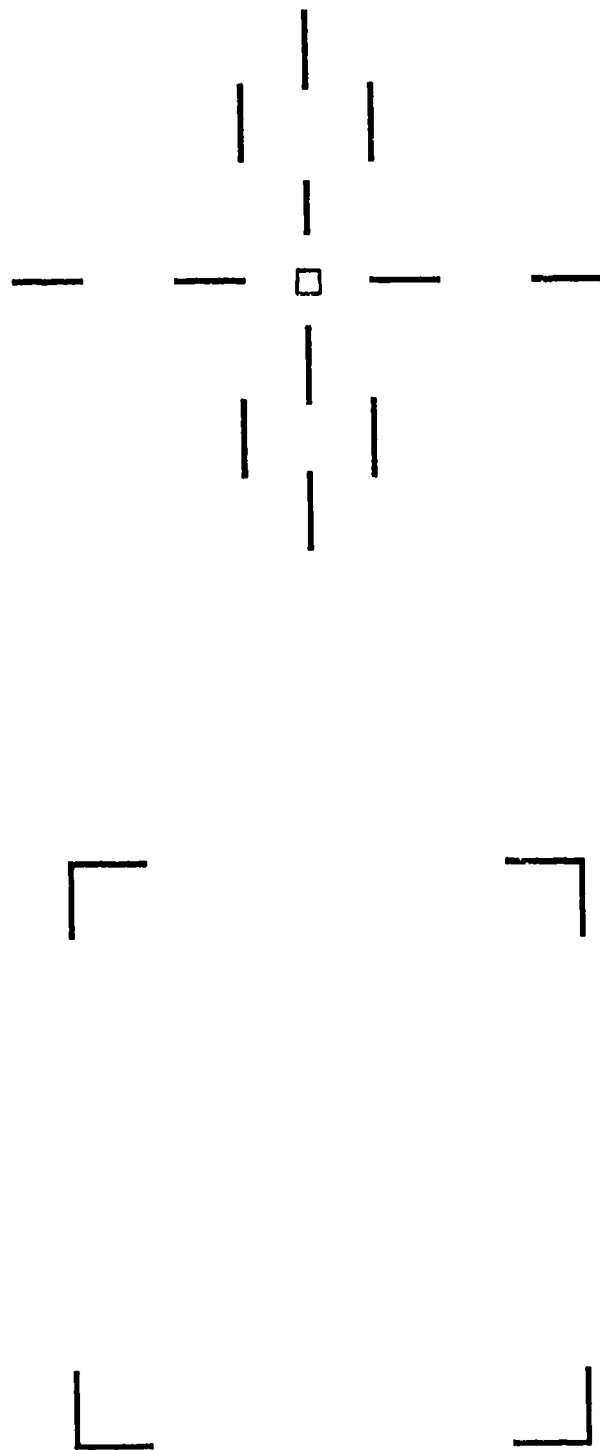

Figure 4a. Reticle for Wide Field of View (3X).

Figure 4b. Reticle for Narrow Field of View (10X).

operator performance. That is, this icon will be designed to allow three components of the icon to move--the chassis, the main gun tube, and the CITV. The supporting software for the orientation icon will provide the capability to easily present any combination of the three components (e.g., stationary chassis, moving gun tube and CITV, or moving chassis and gun tube, stationary CITV).

The main gun information presented on the display face is identical to that presented in the gunner's primary sight extension. These redundant features should eliminate the commander's need to alternate between the CITV and the gunner's primary sight extension to obtain needed information. This information includes but is not limited to the range that presents the current main gun to target range in a three or four digit presentation, a range return status and a fire control systems malfunction indicator. If the range return status indicates a multiple return, a bar appears above the range presentation. If a fire control systems malfunction occurs, then an "F" appears to the right of the range presentation. Further main gun information can be found in TM 9-2350-255-10.

CITV Control Panel. There are several controls associated with the operation of the CITV. For purposes of this document, they will first be described as prescribed in the CIDS document or the appropriate U.S. Army document. The required description will be followed by additions or deletions that were deemed necessary for research in the simulator. Again, this includes the concept of selective fidelity, where some of the function switches will be represented visually but rendered inoperable in the actual simulation or where the function can be selectively turned on and off for experimentation purposes. The operational status for each switch will be indicated after the description is completed. The proposed control panel to be used in the simulation research is shown in Figure 3.

Operational Mode Switches

There are three modes of operation associated with the use of the CITV: the Gun-Line-of-Sight (GLOS), the Independent Surveillance, and the Override for Acquisition. For simplicity, operator utility, and to better represent the actual functions, the names of two of the mode switches have been changed from the original CIDS document. The Independent Surveillance mode is now represented by two mode switches now designated as AUTO SCAN and MANUAL SEARCH. The Override for Acquisition is referred to as the DESIGNATE and is located on the commander's control handle. The GLOS maintains the original designation.

These modes and their complementary functions are shown in Figure 5 and explained in subsequent paragraphs. The mode switches located on the control panel are designed such that upon

COMMANDER'S INDEPENDENT THERMAL VIEWER (CITV)
OPERATIONAL MODES

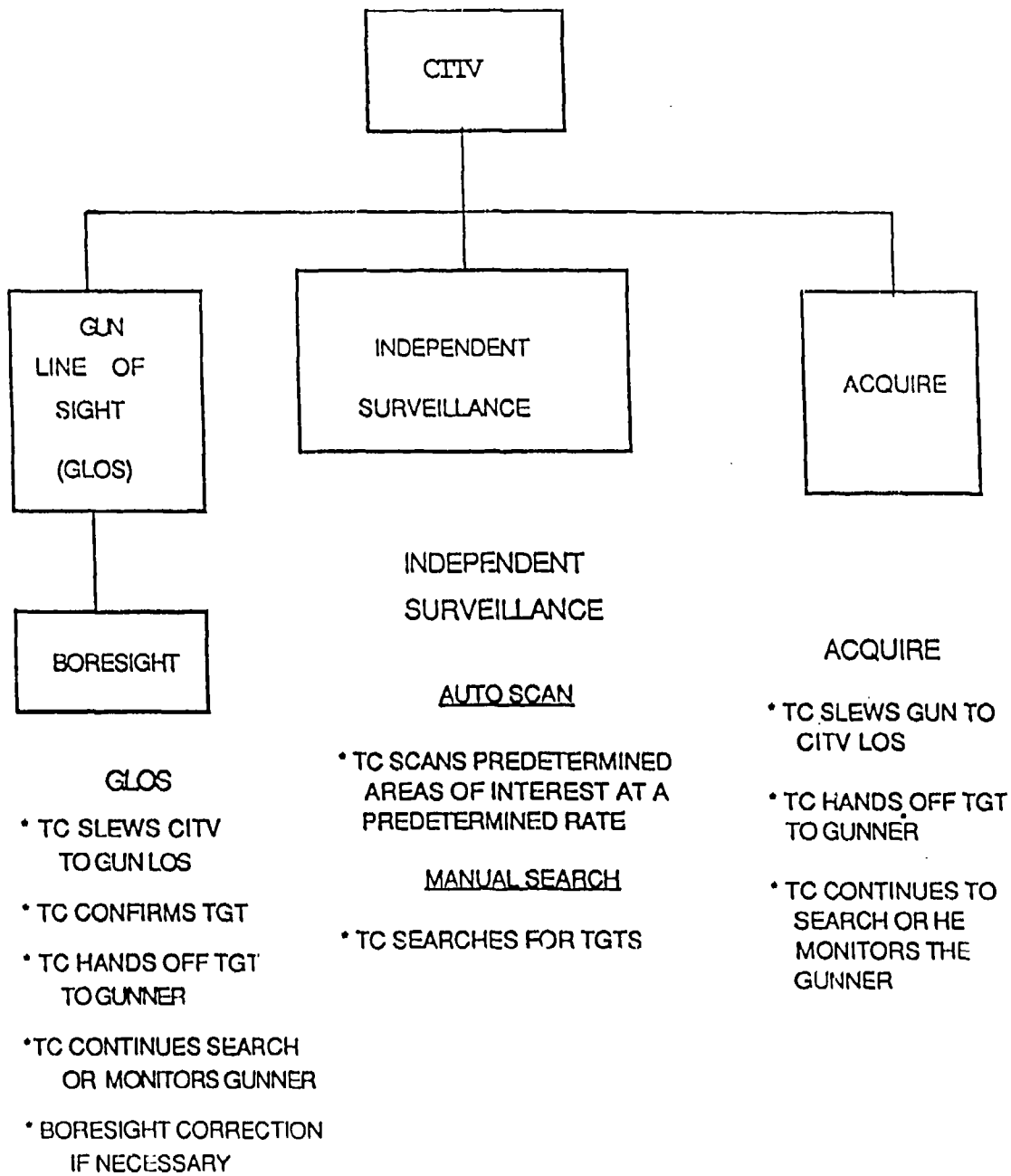

Figure 5. Operational Modes Chart

activation they will be illuminated to allow the commander to be cognizant of the operational mode at any time during CITV use.

Gun Line of Sight

When the CITV is activated in a fully operational system it will automatically perform a self test. After the CITV self test is completed, the CITV Sensor Unit will revert automatically into the GLOS mode. While in the GLOS mode, the CITV is slaved to maintain its own line of sight parallel to the main gun. This parallel alignment should be $\pm 0.1^\circ$ mils. As a point of explanation the CITV has an independent stabilization system. That is, if the CITV has been guided to a specific target area, the CITV will remain affixed to that area no matter what positions the chassis or turret take.

For purposes of the simulation research, the GLOS mode will automatically be selected when the CITV is turned on and may be reselected at any time using the GLOS switch on the control panel. In either of these cases, the GLOS switch will be illuminated. The CITV will remain in the GLOS mode, with the switch illuminated, until the commander selects another mode.

Boresight. The boresight capability, as described in the CIDS document, is functionally a submode of the GLOS. That is, in order to boresight, two switches must be activated--the GLOS and also the switch labeled BORESIGHT. Boresighting is accomplished via a CITV/MIA1 system interface where the CITV's line of sight will be slaved parallel to the main gun, and the CITV's independent stabilization will be turned off. The CITV line of sight can then be adjusted to coincide with the pointing angle of the main gun using the INC (increase) and DEC (decrease) switches. The CITV will remain in this mode until another function is selected.

For the purposes of the simulation research, the GLOS should be designed as described above and fully functional. There should be a BORESIGHT microswitch, but it need not function. Future research, however, that necessitates a complete task analysis may require that the functions be operational.

Independent Surveillance

This mode, redesignated in this research as AUTO SCAN and MANUAL SEARCH, allows the commander to automatically search predetermined sectors at a fixed rate or to manually control the CITV. This surveillance is completely independent of the gunner's field of view.

Auto Scan. The AUTO SCAN provides the commander the capability to survey a predetermined area without the constant use of

the commander's control handle. The capability is activated through a preselection procedure involving one mode switch and two functional switches: the AUTO SCAN, the SECTOR SET, and the RATE SET, respectively. The preselection of sector limits and scan rates also involves the use of the commander's control handle. When using the automatic scan mode, the commander is able to select any azimuth sector angle up to 270° (see Figure 1 for the 270° parameters) and the CITV's line of sight will remain stabilized. The procedure for preselection and use of the automatic scanning capability is briefly explained in the following paragraphs and shown in Appendix A.

Automatic Scanning Procedures. There are at least four options associated with the automatic scanning procedure. The first option is the preselection of both sector and rate. This could occur during pre-operational checks or when a commander desires a change in his current sector and rate parameters. The second is no change in the predetermined sector and rate. The third is a determination of new sector limits but retention the current (default) rate. The last option is changing of the rate of scan to the commander's preference. Options two, three and four are associated with changes during actual operation of the CITV. Before the commander can use the AUTO SCAN mode for any of the options, several actions are necessary. These include sequences that utilize the AUTO SCAN switch, and the SECTOR and RATE SET function switches. All of these switches are located on the CITV control panel. Additionally, there is a requirement for manual displacement of the commander's control handle. These options and the proper sequences are explained in Appendix A.

To initiate the sequence associated with the first option, the commander presses the AUTO SCAN switch. This action readies the system for input regarding the desired sector. This readiness is reflected in several system responses. First, the AUTO SCAN light will be illuminated. Second, there is a corresponding illumination of the SECTOR SET switch and a presentation of the default sector parameters (as with the M1/M1A1, the computer will maintain in memory, the last sector input referred to as the default). This default information will be depicted as an angle on the orientation icon, and upon initiation of sector, with the left side of the angle blinking. With this option, the assumption is made that the commander wants to reselect sector and rate. To accomplish this he engages the palm switch on the commander's control handle and traverses left to the desired limit. He then presses the SECTOR SET switch and releases the palm switch. This locks in the left limit and readies the system for the right limit input. This readiness is reflected by a solid left limit line and a blinking of the right limit of the angle on the orientation icon. The commander then engages the palm switch and traverses right with the control handle to the desired right limit. He again presses the SECTOR SET switch and releases the palm switch. These actions lock in the right limit

and readies the system for the rate input. This ready state is reflected by the lack of illumination on the SECTOR SET switch and the immediate illumination of the RATE SET switch that indicates to the commander that a response is required. To set the rate, the commander engages the palm switch and moves his control handle from right to left at a preferred rate. The system will calculate the rate of scan by the following formula: distance between right and left limits divided by time taken to move commander's handle from right to left. To lock this rate into the system, the commander presses the RATE SET switch and releases the palm switch. To execute the input for both the scan and rate, the commander presses the AUTO SCAN switch. This informs the system that the parameters have been established and the automatic scan mode should commence.

Other options available for the automatic scan are abbreviated forms of the above explained procedure. If the commander presses the AUTO SCAN switch, views the sector default information and is satisfied with both the sector and rate defaults, he can again press the AUTO SCAN switch, bypassing the sector and rate decisions, and immediately initiate the automatic scan. Another option is the determination of the sector parameters with an execution of the default rate. In this case after the commander has chosen the sector parameters and the RATE SET switch is illuminated, he can bypass the rate decision by pressing the AUTO SCAN switch. This action will begin the automatic scanning of the CITV, and will continue in the defined sector at the prescribed rate until the commander either selects a different sector and rate or the CITV is powered down. These sector and rate parameters will, however, be stored in memory, presented as default values at power up, and necessitate a commander's decision to either retain the default parameters or initiate new ones. A final option allows the commander to tailor the rate of scan to his preference during operation. He presses the rate switch and then changes the scan rate using the increase and decrease switches located on the control panel. For purposes of the simulation research, the AUTO SCAN function will be present on the control panel and fully operational. The CITV sector will be represented on the orientation icon as an angle of solid-lines that originate on the inner side of the turret representation. The lines of the angle correspond to the left and right limits of the sector.

Manual Search. The manual search capability is initiated through a switch on the CITV control panel. The rate of search, however, is determined by the movement of the commander's control handle. These actions allow individual preferences in the controlled and stabilized CITV line of sight. The control provides the commander with the capability to manually search for targets and place the CITV's crosshairs on a target before entering the acquisition mode. The CITV will remain in MANUAL SEARCH until the commander selects another operating mode. For

purposes of the simulation research the MANUAL SEARCH function will be present on the control panel and fully operational. The CITV line of sight will be represented on the orientation icon as a dashed line originating on the inner side of the turret representation.

Override for Acquisition

The acquisition mode is referred to in this research as the DESIGNATE. It is used by the commander to designate the target location and to slew the main gun to the CITV's line of sight and hand off the target to the gunner. In order for the commander to execute this slew, a short procedure is necessary to prevent inadvertent activation of the DESIGNATE button. The procedure requires that once the commander has sighted a target, ensure the MANUAL SEARCH switch or the palm switch is engaged, (indicated by the illumination of the MANUAL SEARCH switch positioned the reticle, and checked priority of sightings (e.g., commander vs. gunner) he can actually begin the override.

All of the controls explained in the following procedure are located on the commander's control handle. First, the commander ensures that the OP MODE rocker switch (located on the right side of the control handle) is in the CITV position, then he presses the palm switch and the DESIGNATE button (located on the left side of the control handle). When this button is activated, several system responses occur. The CITV will remain stabilized on the target, and the tank's main gun/turret and the gunner's primary sight are slewed to the CITV's stabilized line of sight. This action renders the main gun and gunner's primary sight slaved to the CITV line of sight.

The CITV will remain in this mode until both of the electrical impulse signals (CITV Designate and Palm Switch) on the interface are no longer present. When the palm switch is released the commander hands off the control of the main gun to the gunner. It should be noted that until the commander does release the palm switch, the gunner is rendered ineffective. That is, his capability to traverse the turret or fire the main gun is disabled. For purposes of the simulation research, these functions should be present and fully operational. Additionally, to enhance the commander-gunner interface, there should be some anticipatory cue given to the gunner preparing him for the slewing of the turret and his primary sight. This cue should be a visual cue that appears in the gunner's sight or on his control panel.

Function Switches

Off

When the CITV operational switch is in the OFF position, the power for the CITV's microprocessor will come on with the tank's turret power. This feature enables the CITV system to respond to

the data bus and the CITV's own power switch. While in the OFF position, the CITV's microprocessor performs a continuous self-test. If a failure is detected, it will be indicated by a red circular fault light located on the control panel.

Standby

When the CITV is in STANDBY, the cooler power will be activated, and the system will automatically begin to cool the appropriate components. When properly cooled, its operational readiness will be indicated by a blinking green light located on the panel and labeled READY.

On

When the ON switch is selected, all of the CITV's power will come on and the system will be checked by the microprocessor. At this point, the green light in the READY indicator will change to a steady illumination. The CITV will run a power self test that checks many of the system's functions, to include the stabilized head mirror and its electronics. The CITV will then begin a continuous, automatic self-test of the system's power and other system functions. In the case of a failure in any of the self tests, the system fault lamp on the display will be lit (red) and the green ready light will go out. The CITV's operational modes can only be accessed when the power switch is in the ON position.

For purposes of this research the tri-function switch described above as OFF/STANDBY/ON will be physically present as a rocker switch located either on the side or bottom of the display control panel. Decisions about the placement of this switch should consider ease of access and also safety of the crew. Simulating the actual times associated with the system's self test and the cool down period is not necessary for the present research. However, correct delay times may be useful in future research and would require a complete task analysis. The CITV FAULT and the READY indicators will be operational in this research.

Built in Test (TEST)

This function is selected by engaging the TEST switch on the control panel. When this function is selected, the CITV will perform its operator-assisted self-test. The self-test, as described in the CIDS document, is a full built-in test (BIT). Its output will inform the operator whether any component within the CITV system has failed, and if so, which component. Faults will be indicated by a red light located on the control panel. In addition to performing the automatic functions of the power self test, this test will cue the operator to observe certain system operations and to press YES NO switches, located on the control panel, in reply to the prompts. This process permits a

more complete evaluation of functions that are not directly accessible to the BIT electronics.

The system remains in this functional state until the BIT designate is disengaged. Faults will be presented in code form, similar to those in the M1A1, on the face of the display.

For purposes of this research, the BIT function is designated TEST to correspond with the M1A1 function. While there is a switch allocated on the panel of the display, the function will not be operational.

Brightness

This function switch corresponds in part to the M1A1 reticle rheostat and allows the capability of viewer preference for both the reticle and other symbol presentations. This multifunction switch should emulate the current brightness range of the M1A1 rheostat. To set brightness the commander only needs to press the function switch (1 press-Reticle, 2 presses-Symbol) and adjust to his preference with the INC DEC switches located on the control panel. For purposes of the simulation research, this function should be present and operational.

Sector Set

An explanation of the SECTOR SET function and characteristics was discussed earlier in the automatic scanning procedure. This switch must be operable for the simulation.

Rate Set

An explanation of the RATE SET function and characteristics of the switch was discussed earlier in the automatic scanning procedure. This switch must be operable for the simulation.

Boresight

A explanation of the BORESIGHT function was discussed earlier in the GLOS description. For purposes of the simulation research, this switch should be present on the control panel but not operable.

Contrast/Sensitivity

This switch provides a capability for individual preference in contrast and sensitivity (brightness). This capability pertains to the presentation of the CITV image and is set using the INC DEC switches. For purposes of the simulation research, this switch should be present on the control panel and operable.

Focus

This switch provides a capability for individual preference in the focus of the CITV presentation. To control the focus of the CITV image, the INC DEC switches are used in conjunction with the FOCUS switch.

For purposes of the simulation research, this switch should be present on the control panel but not operable.

Polarity

The POLARITY switch carries a dual function. It allows operator preference in the CITV's presentation to assist in the interpretation of the thermal images. "Hot" areas in the field of view can be displayed as either white hot (WHOT) or black hot (BHOT). A corresponding indicator will be provided on the switch itself (i.e., one press of the POLARITY switch will change the switch to read WHOT, a second press will change the switch to read BHOT).

For purposes of the simulation research, this switch must be present on the control panel and operable.

Drift (Azimuth and Elevation)

The DRIFT function allows the commander to null out drift in the stabilization of the CITV. Azimuth and elevation null-outs are accomplished using the INC DEC switches located on the CITV control panel. For this simulation research, there is a switch allocated to the DRIFT function on the control panel; however, the function switch will not be operable. Future research which necessitates complete task analyses, may require the DRIFT function to be operational.

Increase/Yes and Decrease/No

These switches are multipurpose in the sense that they are used in conjunction with a number of the main function switches. For example, the INC DEC switches are used to fine tune the background imagery, the reticle, and the polarity to the preference of the user. For the purposes of the simulation research both switches will be present on the control panel as shown in Figure 3. The INC, DEC function switches, designed to fine tune the BRIGHTNESS, BORESIGHT, CONTRAST SENSITIVITY, FOCUS, POLARITY, AND DRIFT switches will only be operable with the BRIGHTNESS, CONTRAST SENSITIVITY, and POLARITY function switches. The YES NO switches, designed to answer questions during the CITV BIT, are not operable.

Field of View

The field of view selection control is located on the bottom of the CITV display unit as shown in Figure 3. This selector is a finger operator slide control, similar to the M1A1 field of view selector. The switch allows the tank commander to choose between two fields of magnification labeled as 3X and 10X. The narrow field of view (10 power magnification (10X)), as described in the CIDS document should represent an approximated 2.5 vertical X 3.3 horizontal area. The wide field of view (3 power magnification (3X)) should represent an approximated 7.5 vertical X 10.0 horizontal area. For purposes of simulation research, this control must be operable.

Commander's Control Handle

The design for the tank commander's control handle is the responsibility of the M1A1 integrating contractor. A recent version of their handle has been modified for use in this simulation research and is shown in Figure 6. This modified design maintains the same overall shape of the handle and, in general, the functions associated with the original handle. However, modifications, which focused on location and designs, were made to prevent inadvertent activation of the DESIGNATE button, and to maximize transfer of knowledge associated with the current system. The commander's control handle includes four functions which are described below.

Trigger

This control activates the firing of either the coaxial mounted 7.62mm machine gun or main gun. This activation is contingent upon the preselection of switches located at the gunner's station. For purposes of CITV simulation research this trigger must be operable.

Palm Switch

This control provides power to the handle to enable certain handle functions switches (e.g., override and firing the gun) and also CITV functional modes. For purposes of simulation the palm switch must be operable.

Operational Mode

This switch is designed as a dual function rocker switch labeled as TURRET/CITV. This switch allows the commander to select operational mode and to be cognizant at all times as to what system he is currently controlling i.e., CITV or main gun. This switch is to be used in conjunction with the palm switch and the LASE/DESIGNATE switch, also located on the commander's handle. For purposes of simulation research, this switch must be operational.

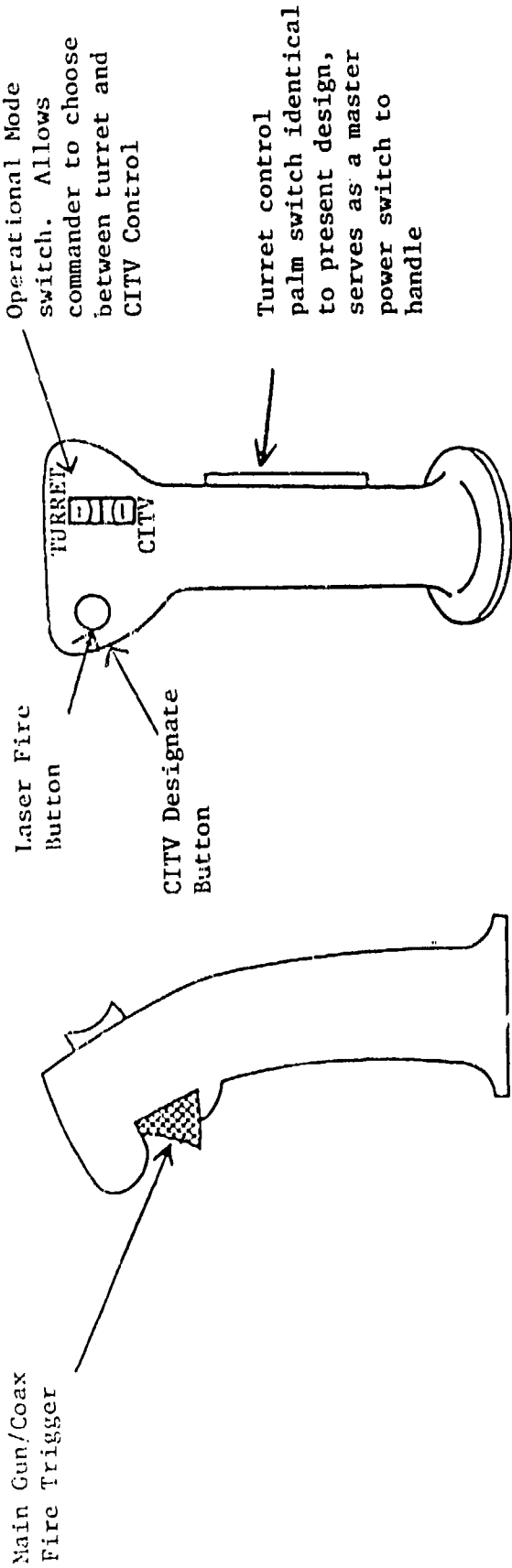

Figure 6. Proposed commander's control handle modified for CITV.

Laser Fire and CITV Designate

This switch has a dual function capability and is to be utilized in conjunction with the OP MODE switch previously described. If the OP MODE switch is in the TURRET position, pressing this switch will allow the commander to use the laser rangefinder while viewing the target through the gunner's primary sight extension. If the OP MODE is in the CITV position, pressing the switch will allow the commander to slew the main gun to the CITV line of sight.

To prevent accidental activation of the CITV function, this switch will not be operational unless the commander has put the OP MODE switch into CITV mode and the palm switch has been pressed. For purposes of CITV simulation research, this switch must be present and fully operable.

Additional CITV Capability for Simulation

There is a section in the CIDS document that is dedicated to the growth potential of the CITV. Many technologies fall under this rubric of growth potential, to include automatic target recognition (ATR), target stacking, and target prioritization. Each of these is an important additional capability to the CITV and each has had, to a certain extent, a separate research effort dedicated to it. To date, however, there is no one consolidated effort to combine all of these technologies into one CITV prototype.

The present research effort does not combine all of these technologies, but it does take advantage of the simulator's operating system and attempts to examine a limited ATR capability. The SIMNET-D includes a semi-automated opposing forces (OPFOR) capability, but more importantly, the system knows the type and location of each OPFOR vehicle at any time during the simulation. This information, combined with the friendly forces identification and location, can be transmitted to the commander via the CITV.

For purposes of this research, the ATR capability will function only in the MANUAL SEARCH mode. When a target of concern is approached, the commander only needs to lay the reticle on the target. The target will then be captured in a geometric form and identified on the display face in close proximity to the target.

DESCRIPTIVE SCENARIO USING CITV PROCEDURES

Upon entering the tank, the commander performs turret power up and moves the CITV power switch to the STANDBY position. In an actual setting, the CITV system components would cool to an

operating temperature. This time would allow the commander to concentrate on other equipment, crew and platoon preparation. When the CITV is ready for use (the READY indicator located on the display is a blinking green light), the commander will move the display power switch to ON. After a brief delay (approximately 40-60 secs), the CITV automatically completes a self test. If no faults are detected, the ready indicator becomes a constant green light and automatically brings the CITV sight into the GLOS mode. If a fault is found in the system, the FAULT indicator located on the control panel would illuminate (red light), directing the commander to resolve the problems with the use of the CITV TEST (BIT) capability.

When the GLOS mode has been entered, the GLOS switch on the control panel is illuminated, and the commander views a scene that represents the gunner's view of the battlefield. The commander can now tailor the CITV image, by focusing and fine tuning the contrast and sensitivity controls. Satisfied with the image, he can engage the MANUAL SEARCH switch on the control panel to change operational modes and thus gain the independent viewing capability (CITV line of sight).

If the CITV is to be used as a platoon enhancement, the commander would coordinate with adjacent tank commanders to determine responsibility for individual viewing sectors. When the sectors are established, the commander inputs the sector parameters and scan rates using the procedure explained previously in this document. Upon completion of this procedure, the commander engages the palm switch on the control handle and presses the AUTO SCAN switch to begin his surveillance.

When a suspected target is detected, during this surveillance, the commander engages the palm switch on the control handle or presses the MANUAL SEARCH switch to stop the automatic scan and attempts to accurately identify the object. This identification can be accomplished through the automatic target recognition capability by simply laying the reticle on the target. The commander can also visually identify the target. If the target is identified as a threat, the commander issues a fire command, depresses the palm switch and presses the CITV DESIGNATE, located on the control handle to bring the turret, /main gun onto the target. Once the gunner identifies the threat, the commander then hands off the target to the gunner for engagement and resumes the target surveillance by releasing his control handle and pressing the AUTO SCAN switch. Upon hearing the gunner's round observation, the commander can move his head briefly to the gunner's primary sight extension to confirm a target hit/kill or assist the gunner in destroying the threat, or he can continue to search for additional targets delegating responsibility for damage assessment to the gunner.

FUTURE ENHANCEMENTS FOR CITV SIMULATION

The generic CITV that is presented in this document for simulator research is, at best, a stripped-down version of the original CITV concept. This version does, however, provide a system to which enhancements can be added as the technology associated with both the CITV and the SIMNET-D increase. Moreover, the concept of these enhancements, can be tested much earlier and more stringently from a soldier involvement standpoint than by using current Army models and field tests.

There are many enhancements proposed for the CITV that could eventually be tested through the use of simulation. Most of these center on the desire to lessen the workload of the tank commander by reallocating many of his operating functions to the equipment. One of these enhancements is a sophisticated ATR capability that allows the commander, especially on a target rich battlefield, to expediently identify the most serious threat and direct his gunner to that location.

A second enhancement builds on this identification capability and is referred to as target stacking. Using this capability the commander can search the area designate a target by identification and location and store it in the system's memory. The gunner, after completing an engagement, would then be automatically slewed to the next target that was stored in the memory.

A third enhancement builds on both the ATR and target stacking capabilities and is referred to as target prioritization. Target prioritization requires a fairly intelligent system, that can determine the criticality of the target through consideration of characteristics such as: the type of target, its current operational status (e.g., defilade, gun orientation, stationary, or moving), and its current location. Using this capability, the commander can designate which targets he wants to store, the system then decides which target is next in queue, and the gunner is then automatically slewed to the most critical of the targets.

The last, but not least, of the future enhancements for simulation research is the CITV - BMS integration. This integration would include the physical locations of the displays, the design of controls used by both systems, and the automatic transmissions of necessary information directly from the CITV through the BMS. As mentioned in the introduction of this document, CITV was originally thought to be an integral component of the BMS system. If both of these systems are to be built into the tank, their integration is critical to the operational effectiveness of the commander. This point is emphasized because with the design of each component there is an associated operator workload. When the workload associated with two new systems becomes too demanding, the individual most would consider already

stressed, will quickly reach his performance limits and total system effectiveness will decrease.

REFERENCES

- Elton, R. E. (1986). MANPRINT (Manpower and Personnel Integration). Proceedings of the Human Factors Society 30th Annual Meeting.
- General Dynamics Land Systems Division (ed) (1985). Improved M1A1 Tank Program. Critical Item Development Specification for Commander's Independent Thermal Viewer System (U) (Vol. 1. SB-X17105E). Warren, MI.
- Hyman, A. (1987). Enhancing the display interface of the Commander's Independent Thermal Viewer. Army Research, Development & Acquisition Magazine Jan/Feb, 11-13.
- Pengelle, R. (1986). Putting steel on the target: U.S. tank fire control. International Defense Review, 12, 1823-1829.
- Pickard, J. C. & Boismier, J. D. (1985). M1A1 Block II Commander's Independent Thermal Viewer: A Comparative Study of Motion Sickness in Biocular and Direct View Displays. General Dynamics Technical Report 8314-TR-005-181185. Warren, MI.
- Quinkert, K. A. (1987). Preliminary Training Requirements Analysis for the Commander's Independent Thermal Viewer (CITV). U.S. Army Research Institute for Behavioral and Social Sciences Research Product 87-19. Alexandria, VA. (AD A185 467)
- Quinkert, K. A. and Black, B. A. (1987). Simulation Networking: A MANPRINT Tool. Army Research, Development & Acquisition Magazine, Nov/Dec, 8-11.
- Schaad, G. and Steinberg, S. (in press). Commander's Independent Thermal Viewer Symbology Presentation Study. HEL Technical Memorandum. U.S. Army Human Engineering Laboratory, Aberdeen Proving Ground, MD.
- U.S. Department of the Army. (1982). Operations. Field Manual (FM 100-5). Washington, DC: Headquarters, Department of the Army.
- U.S. Department of the Army. (1986). Manpower and Personnel Integration (MANPRINT) in the Material Acquisition Process. Army Regulation (AR 602-2). Washington, DC: Headquarters, Department of the Army.

U.S. Department of the Army. (1981). Operator's Manual, Tank, Combat, Full-Tracked: 105-MM Gun, M1. Technical Manual (TM 9-2350-255-10). Washington, DC: Headquarters, Department of the Army.

U.S. Department of the Army. (1985). Operator's Manual, Tank, Combat, Full-Tracked: 120-MM Gun, M1A1. Technical Manual (TM 9-2350-264-10). Washington, DC: Headquarters, Department of the Army.

APPENDIX A

EXECUTION PROCEDURES FOR AUTO SCAN CAPABILITY

Table A.1

Execution Procedure for the Complete Auto Scan Capability

Step	Soldier Action	System Response
1.	Press AUTO SCAN	-Auto Scan switch is illuminated -Sector Scan switch is illuminated -Default Sector appears on orientation icon -Left default limit appears as a blinking line
2.	Press SECTOR SET	-Left default indicator disappears
3.	Engage Palm Switch on Control Handle and traverse to the desired left limit	
4.	Press SECTOR SET and release Palm Switch	-Locks in left limit -Right default limit appears as a blinking line
5.	Engage Palm Switch on Control Handle and traverse to the desired right limit	-Right default indicator disappears
6.	Press SECTOR SET and release the Palm Switch	-Locks in right limit -Sector Set switch light is extinguished -New sector limits are displayed on orientation icon -Rate Set switch is illuminated -Default rate is shown
7.	Press RATE SET	-Scan terminates
8.	Engage Palm Switch and traverse the control handle from right to left at the desired rate	

9. Press AUTO SCAN and
release the Palm Switch

- Rate Set switch light is
extinguished
 - Locks in new rate
 - Auto Scan switch light
remains illuminated
 - CITV begins automatically
scanning the desired sector
at the desired rate
-

Table A.2

Execution Procedure for the Partial Auto Scan Capability

Step	Human Action	System Response
Option 1		
Commander desires to view default conditions-no changes required		
1. Press AUTO SCAN		<ul style="list-style-type: none"> -Auto Scan switch is illuminated -Sector Scan switch is illuminated and left default indicator appears
2. Press SECTOR SET and engage the palm switch		<ul style="list-style-type: none"> -Left default indicator disappears -Right default indicator appears
Commander decides to retain default settings for sector		
3. Releases palm switch		-System bypasses sector set
4. Engage Palm Switch and press AUTO SCAN		<ul style="list-style-type: none"> -Sector Set switch is extinguished -Auto Scan switch remains illuminated -CITV begins automatically scanning the default sector at the default rate

Table A.3

Execution Procedure for the Partial Auto Scan Capability

Step	Human Action	Systems Response
------	--------------	------------------

Option 2

Commander desires to change the sector limits, but retain the default rate

1. Complete steps 1-6 listed in Table A.1	-Reset the sector values
2. Engage Palm Switch and Press Auto Scan	-Locks in the default rate value -Rate Set switch is extinguished -Auto Scan switch light remains illuminated -CITV begins automatically scanning the new sector at the default rate

Table A.4

Execution Procedure for the Partial Auto Scan Capability

Step	Human Action	Systems Response
------	--------------	------------------

Option 3

Commander desire to change rate of scan value at any time during operation

1. Press RATE SET	-CITV continues to scan at set rate
2. Press INC or DEC switch	-Tailors scan rate to commander's preference -Stores new rate as default value
