

# AD-A201 452 REPORT DOCUMENTATION PAGE

1

1. UNCLASSIFIED		51. RESTRICTIVE MARKINGS	
2a. SECURITY CLASSIFICATION AUTHORITY <b>SELECTED</b>		52. DISTRIBUTION / AVAILABILITY OF REPORT Approved for public release; Distribution unlimited	
2b. DECLASSIFICATION / DOWNGRADING SCHEDULE NOV 04 1988			
4. PERFORMING ORGANIZATION REPORT NUMBER(S) AFGL-TR-88-0245		53. MONITORING ORGANIZATION REPORT NUMBER(S)	
6a. NAME OF PERFORMING ORGANIZATION Air Force Geophysics Laboratory	6b. OFFICE SYMBOL (if applicable) PHK	7a. NAME OF MONITORING ORGANIZATION	
6c. ADDRESS (City, State, and ZIP Code) Hanscom AFB Massachusetts 01731		7b. ADDRESS (City, State, and ZIP Code)	
8a. NAME OF FUNDING / SPONSORING ORGANIZATION	8b. OFFICE SYMBOL (if applicable)	9. PROCUREMENT INSTRUMENT IDENTIFICATION NUMBER	
8c. ADDRESS (City, State, and ZIP Code)		10. SOURCE OF FUNDING NUMBERS	
		PROGRAM ELEMENT NO. 63410F	TASK NO. 2823
		WORK UNIT NO. 01	WORK UNIT ACCESSION NO. 01
11. TITLE (Include Security Classification) An Automatic Charge Control System for Satellites			
12. PERSONAL AUTHOR(S) B. M. Shuman, H. A. Cohen			
13a. TYPE OF REPORT REPRINT	13b. TIME COVERED FROM _____ TO _____	14. DATE OF REPORT (Year, Month, Day) 1988 September 26	15. PAGE COUNT 5
16. SUPPLEMENTARY NOTATION Presented at the Spacecraft Environmental Interactions Technology Conf, USAF Academy, Colorado Springs, CO, 4-6 October 1983			
17. COSATI CODES		18. SUBJECT TERMS (Continue on reverse if necessary and identify by block number)	
FIELD	GROUP	Spacecraft charging                      Charge control	
19. ABSTRACT (Continue on reverse if necessary and identify by block number)			
<p>→ SCATHA as well as the ATS-5 and -6 spacecraft have provided some answers and insights to the problem of spacecraft charging at geosynchronous altitudes. In particular they have indicated the approach to reducing the levels of both absolute and differential charging -- namely, by the emission of low energy neutral plasma. It is now appropriate to complete the transition from experimental results to the development of a system that will sense the state-of-charge of a spacecraft, and, when a predetermined threshold is reached, will respond automatically to reduce it. The Air Force is embarking on such a development program, utilizing sensors comparable to the proton electrostatic analyzer, the surface potential monitor, and the transient pulse monitor that flew in SCATHA, and combining these outputs through a microprocessor controller to operate a rapid-start, low energy plasma source. A flight-ready system should be available for spacecraft integration by 1988.</p>			
20. DISTRIBUTION / AVAILABILITY OF ABSTRACT <input type="checkbox"/> UNCLASSIFIED/UNLIMITED <input type="checkbox"/> SAME AS RPT. <input type="checkbox"/> DTIC USERS		21. ABSTRACT SECURITY CLASSIFICATION Unclassified	
22a. NAME OF RESPONSIBLE INDIVIDUAL		22b. TELEPHONE (Include Area Code)	22c. OFFICE SYMBOL

## AN AUTOMATIC CHARGE CONTROL SYSTEM FOR SATELLITES

B.M. Shuman and H.A. Cohen  
Air Force Geophysics Laboratory

## SUMMARY

SCATHA as well as the ATS-5 and -6 spacecraft have provided some answers and insights to the problem of spacecraft charging at geosynchronous altitudes. In particular they have indicated the approach to reducing the levels of both absolute and differential charging -- namely, by the emission of low energy neutral plasma. It is now appropriate to complete the transition from experimental results to the development of a system that will sense the state-of-charge of a spacecraft, and, when a predetermined threshold is reached, will respond automatically to reduce it. The Air Force is embarking on such a development program, utilizing sensors comparable to the proton electrostatic analyzer, the surface potential monitor, and the transient pulse monitor that flew in SCATHA, and combining these outputs through a microprocessor controller to operate a rapid-start, low energy plasma source. A flight-ready system should be available for spacecraft integration by 1983.

## INTRODUCTION

This paper is by way of announcing the Air Force's intent to carry out the technology transition from SCATHA to the next logical phase -- namely, the development of an automatic charge control system for spacecraft. The problem of spacecraft charging as a potential hazard for Air Force satellites operating in deep space has been recognized now for just over a decade. The buildup of spacecraft charge and its subsequent discharge, particularly at geosynchronous orbit, can limit the performance and operational lifetime of satellites. The arcs generated in this fashion can couple into the command and data lines of the spacecraft causing spurious signals, triggering erratic commands, and destroying solid-state electronics. The SCATHA satellite, which was dedicated solely to this problem, was launched to near geosynchronous orbit with a full range of sensors (ref. 1) to determine the spacecraft state-of-charge as well as the background conditions in space when the charging occurred. Also on board were the AFGL active experiments, the electron gun and the SPIBS positive ion gun, which could be used to swing the potential of the satellite either positive or negative on command. One of the alternate operating modes of the SPIBS ion gun was as a neutral plasma source, and that proved to be the safest and most effective method of reducing both absolute and differential charging on the satellite (ref. 2). These SCATHA results, as well as those from the NASA ATS-6 satellite using a cesium plasma bridge neutralizer (ref.3), have shown that a charged spacecraft, and the dielectric surfaces on it, could be safely discharged by emitting a very low energy ( $< 50$  eV) neutral plasma -- in effect "shorting" the spacecraft to the ambient plasma before dangerous charging levels could be reached. This technique forms the basis for our Flight Model Discharge System (FMDS), which is to be an active charge control system for satellites that will operate automatically in space.

## SYSTEM DESCRIPTION

Much of the development of the FMDS, particularly with regard to the state-of-charge sensors, follows directly from the SCATHA technology. A block diagram of the system is shown in figure 1. The heart of the system is the low energy plasma source. The major change from its SCATHA predecessor is that it must be capable of a simple and rapid start-up -- responding within ten seconds. The microprocessor controller will be the "brains" of the system, interpreting the three different charging sensor outputs, and "deciding" when to turn on the plasma source. The electrostatic analyzer (ESA) will detect incoming protons in different energy channels to provide a measure of the absolute charging of the spacecraft. Since a negatively charged satellite will accelerate ambient protons up to its potential, the lowest energy channel at which sizeable fluxes of protons are detected would correspond to the absolute charging level of the spacecraft (i.e. relative to the ambient plasma in space). The surface potential monitor will measure the differential spacecraft charging (i.e. the potential developed on insulating surfaces relative to spacecraft frame ground). Essentially, the back surface voltage of a dielectric sample (i.e. kapton, teflon, etc.) is measured with an electric field sensor, and that in turn is translated into a front surface potential by means of a prior vacuum chamber calibration. The transient pulse monitor will detect arc discharges occurring on the external surfaces of the

## FLIGHT MODEL DISCHARGE SYSTEM

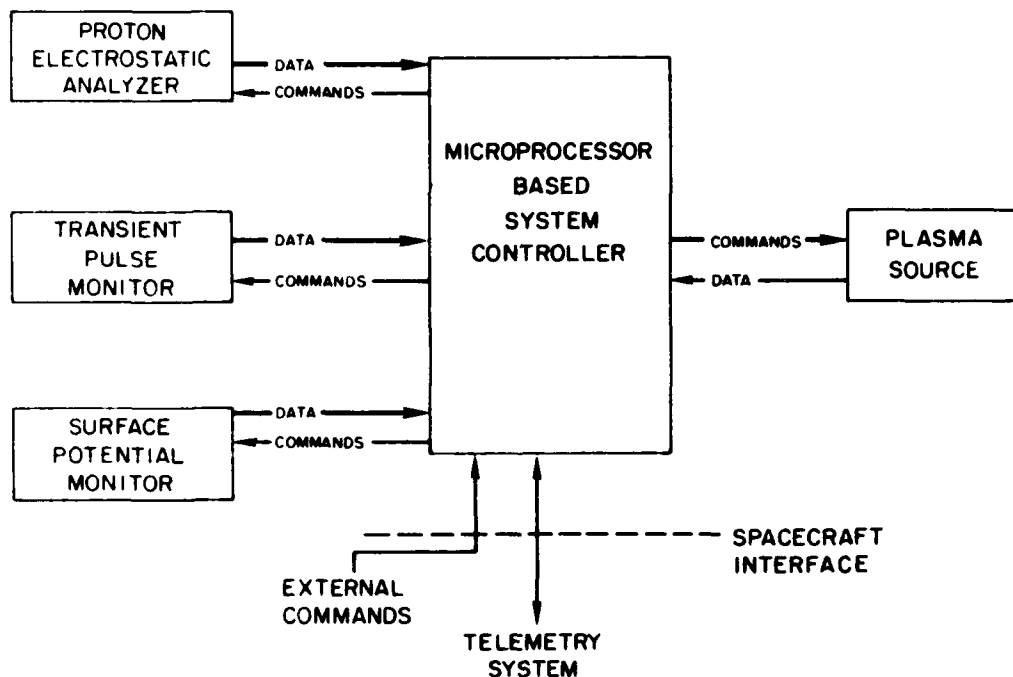

Figure 1

spacecraft by measuring the radiated electromagnetic noise pulses. The pulse characteristics should provide the means of discriminating between arc discharges and spacecraft-generated noise. The combination of these three different sensors should provide a good indication of the state of spacecraft charging, but any one alone (by exceeding a preset threshold level) will be able, via the controller, to activate the plasma source and reduce the charging.

Considering each of the components in somewhat more detail, we come back to the plasma source. This will produce a low energy (<50 eV) neutral plasma where the ions are derived from a noble gas. Xenon was chosen as the active source for the SPIBS experiment on SCATHA, and would be a likely choice here as well. The ion current levels would be selectable by remote command -- 10  $\mu$  A, 100  $\mu$  A, or 1 mA. On SCATHA, SPIBS discharged the vehicle from a potential of -3kV using as little as 6  $\mu$  A of current. The plasma source will be simpler than SPIBS in that neither multi-energetic positive ion beams nor electron beams will be required. However, the activation process must be far simpler and quicker than for SPIBS since it will be turned on automatically by the controller, and must be capable of responding within ten seconds. The plasma source will have the capability for 1200 hours of operation in space, with at least 1000 on-off cycles. This is expected to be more than enough to operate for three years, with a large safety factor besides. There will be monitor outputs to telemetry for plasma current flow, remaining gas supply, command status, and other diagnostics. Provisions will be made, as was the case for SPIBS, for a vacuum enclosure around the plasma source to allow for operation during spacecraft integration checks. The weight of the plasma source will be less than 10 pounds, and the power required for operation will be less than 10 watts.

The proton electrostatic analyzer will measure the incident proton spectra in the energy range from less than 100 eV to 20 KeV. It will be simpler than the ESAs used on SCATHA since it will require, as a minimum, only eight incremental energy channels, with maximum channel energies (i.e. upper edge of full width at half maximum [FWHM]) nominally set at 100 eV, 200 eV, 500 eV, 1 KeV, 2 KeV, 5 KeV, 10 KeV, and 20 KeV. The energy channels will be adjacent, and with a minimum of overlap at FWHM -- not more than 2% of the channel central energy. The algorithms developed by Spiegel (ref. 4) to allow for automated interpretation of the ESA data depend critically on the energy channels being sharply defined. The sweep period for the ESA to sample all channels, which determines the time-scale for the detection of spacecraft charging, will be selectable by external command -- 1 second, 5 seconds, or 10 seconds. The ESA will include a sun sensor to reduce electron multiplier gain when the instrument looks toward the sun, and also a control grid to prevent the low energy (< 50eV) ions from the on-board plasma source from being counted. There will also be available, by external command, the possibility of changing the bias voltage of the electron multiplier detector in order to offset the effects of degradation, and to extend its operating lifetime in space. The weight of the ESA will be less than 5 pounds, and the power requirement will be less than 1 watt.

The surface potential monitor will measure the back surface voltage of a dielectric sample as in the SCATHA SC-1 experiment. The surface potential and polarity will be determined once per second, and will include the range 100 volts to 20 kilovolts. The instrument will use two different dielectric samples in flight. These will be chosen prior to flight from a previously-calibrated selection of at least six different samples of "typical satellite dielectric surfaces" such

as aluminized kapton, silvered teflon, fused silica cover glass, etc. Weight and power for the instrument should be less than 3 pounds and 2 watts, respectively.

The transient pulse monitor (TPM) will detect arc discharges occurring on the external surfaces of the spacecraft by measuring the radiated electromagnetic noise pulses with an externally mounted dipole sensor. Similarly to the SRI instrument on SCATHA, it will record the number of pulses counted over each one-second interval; also the maximum pulse amplitude (both positive and negative) occurring over that interval, and the integral of the signal (both positive and negative) over the interval. It will determine pulse width, with the capability of detecting pulses from 10 nanoseconds to 10 microseconds. It will also accommodate amplitudes of electric field strength from 10 kilovolts/meter down to 10 volts/meter. Multiple threshold levels, selectable by external command, will be provided to determine the minimum signal level above which pulses will be recorded. Multiple attenuator levels, to determine the overall gain of the system, will also be selectable by external command. Protection will be provided against ringing by incorporating a dead time that will limit pulse counts to once per millisecond. One phase of the calibration of the transient pulse monitor will include the detection of simulated spacecraft arc discharges -- such as may be induced in a vacuum chamber by bombarding a typical spacecraft thermal control material with energetic electrons. The weight and power requirements for this instrument should be less than 3 pounds and 3 watts, respectively.

The controller will be the nerve center and coordinator of autonomous operation of the charge control system. It will accept inputs from the state-of-charge sensors (i.e. the proton ESA, the surface potential monitor, and the transient pulse monitor), interpret the sensor data based on previously stored algorithms, determine when pre-established threshold levels of charging have been met and then activate the plasma source, and finally, turn off the plasma source when the spacecraft has been discharged. Once activated by the controller, the plasma source will remain operating for a fixed time period. That time period will be selectable by remote command, and will include the nominal intervals of 5, 10, 30, and 60 minutes. The threshold levels at which the plasma source will be activated will also be selectable by external command, and will include at least the (absolute and differential) potential levels 200, 500, 1000, and 2000 volts. Indications of spacecraft arcing, as determined by the TPM will also cause the plasma source to be activated. The algorithm for determining the occurrence of spacecraft arcing from the TPM data will have the capability of being modified in-flight by external command so that it will not respond to the normal background level of electromagnetic noise from the spacecraft itself. As a safety measure, the controller will also incorporate the capability for external-command override of the operation of the plasma source -- for turn-on, turn-off, and current level settings. Finally, the controller will contain sufficient excess capacity to accommodate an additional sensor input, if that should turn out to be desirable at some future date. Allotting approximately 5 pounds and 3 watts for the controller brings the system totals for weight and operating power (with the plasma source on) to 26 pounds and 19 watts. System power requirements with the plasma source not operating will be 9 watts.

We expect the development, fabrication, and test of the charge control system to take approximately four years, so that it would be available for spacecraft integration in 1988. Our present plan is to test-fly the system on a polar-

orbiting Space Shuttle, along with other AFGL-sponsored experiments. The ultimate test of the system will require a flight at geosynchronous orbit, which is the regime this system is primarily designed for and where it will be of most value.

REFERENCES

1. Stevens, J.R., and A.L. Vampola: Description of the Space Test Program P78-2 Spacecraft and Payloads, SAMSO TR-78-24, 1978.
2. Cohen, H.A., and S. Lai: Discharging the P78-2 Satellite Using Ions and Electrons, Paper No. AIAA-82-0266, presented at the AIAA 20th Aerospace Sciences Meeting, Orlando, Florida, January, 1982.
3. Purvis, C.K., and R.O. Bartlett: Active Control of Spacecraft Charging, Progress in Astronautics and Aeronautics: Space Systems and Their Interactions with Earth's Space Environment, Vol. 71, edited by H.B. Garrett and C.P. Pike, AIAA New York, 1980, pp. 299-317.
4. Spiegel, S.L., R.J. Raistrick, N.A. Saflekos, M.S. Gussenhoven, and H.A. Cohen: Real Time, Automatic Vehicle Potential Determination from ESA Measurements, Part I: The Count Ratio Algorithm, Paper No. AIAA-82-0267, presented at the AIAA 20th Aerospace Sciences Meeting, Orlando, Florida, January, 1982.



Accession For	
NTIS CRA&I	<input checked="" type="checkbox"/>
DTIC TAB	<input type="checkbox"/>
Unannounced	<input type="checkbox"/>
Justification	
By _____	
Distribution/	
Availability Codes	
Dist	Avail and/or Special
A-1	