

AD-A201 686

DESIGN OF A HOLOGRAPHIC ILLUMINATION SYSTEM FOR AN INTEGRATED-OPTICS TIME-INTEGRATING CORRELATOR (U)

by

N. Brousseau and J.W.A. Salt

DTIC
ELECTE
DEC 14 1988
S H D

DEFENCE RESEARCH ESTABLISHMENT OTTAWA
TECHNICAL NOTE 88-24

Canada

September 1988
Ottawa

DISSEMINATION STATEMENT A
approved for public release
Distribution Unlimited

88 12 14 027



National
Defence

Défense
nationale

DESIGN OF A HOLOGRAPHIC ILLUMINATION SYSTEM FOR AN INTEGRATED-OPTICS TIME-INTEGRATING CORRELATOR (U)

by

N. Brousseau and J.W.A. Salt
Communications Electronic Warfare Section
Electronic Warfare Division

DEFENCE RESEARCH ESTABLISHMENT OTTAWA
TECHNICAL NOTE 88-24

PCN
041LK11

September 1988
Ottawa

ABSTRACT

The design and implementation of a first prototype of a holographic illumination system for an integrated-optics Time-Integrating Correlator (TIC) are described. Correlation signals obtained with the TIC and the holographic illumination system are shown.

RÉSUMÉ

On décrit l'élaboration et la construction d'un premier prototype d'un système d'illumination holographique pour un Corrélateur à Intégration Temporelle (CIT). Des exemples de signaux de corrélation produits par le CIT et l'illumination holographique sont présentés.



Accession For	
NTIS GRA&I	<input checked="" type="checkbox"/>
DTIC TAB	<input type="checkbox"/>
Unannounced	<input type="checkbox"/>
Justification	
By _____	
Distribution/ _____	
Availability Codes	
Dist	Avail and/or Special
A-1	

EXECUTIVE SUMMARY

Special processors, such as optical Time-Integrating Correlators (TIC), have the ability to provide certain information about spread spectrum signals that may facilitate the initial synchronization of the user to his code. A TIC can be built using integrated-optic technology but the associated illumination system involves a lot of equipment and occupies a large space because of the requirement to produce two wide aperture beams offset in angle.

This report describes the successful construction at DREO of a first prototype of a compact illumination system for a TIC using holography. The hologram produced after reconstruction, the illumination necessary to operate the TIC, allows a dramatic reduction in size of the system and demonstrates the feasibility of using holography for that type of applications. The set-ups used to record and reconstruct the hologram are described and the operation of the TIC with the prototype hologram as an illumination system is demonstrated.

TABLE OF CONTENTS

	<u>PAGE</u>
ABSTRACT	iii
EXECUTIVE SUMMARY.	v
TABLE OF CONTENTS.	vii
LIST OF FIGURES.	ix
1.0 INTRODUCTION	1
2.0 REQUIREMENTS FOR THE ILLUMINATION SYSTEM	1
3.0 CONVENTIONAL ILLUMINATION SYSTEM FOR A TIC	9
4.0 PROOF OF CONCEPT HOLOGRAM.	14
5.0 SELECTION AND TESTING OF THE LENS.	14
6.0 CONSTRUCTION OF A FIRST PROTOTYPE HOLOGRAM	20
7.0 CONCLUSION	25
8.0 REFERENCES	25

LIST OF FIGURES

	<u>PAGE</u>
FIGURE 1: A TIME-INTEGRATING CORRELATOR USING BULK ACOUSTO-OPTICS INTERACTION	2
FIGURE 2: THE INTEGRATED-OPTICS CORRELATOR MODULE	3
FIGURE 3: A TIME-INTEGRATING CORRELATOR USING INTEGRATED-OPTICS ACOUSTO-OPTICS INTERACTION AND A CONVENTIONAL ILLUMINATION SYSTEM	4
FIGURE 4: SCHEMATIC OF A TIME-INTEGRATING CORRELATOR USING INTEGRATED-OPTICS INTERACTION AND A HOLOGRAPHIC ILLUMINATION SYSTEM	5
FIGURE 5: SCHEMATIC OF A CONVENTIONAL ILLUMINATION SYSTEM USING TWO LENSES.	6
FIGURE 6: AMPLITUDE FO THE FIELD DISTRIBUTION OF THE TE ₀ MODE FOR Ti:LiNbO ₃ INDIFFUSED WAVEGUIDE (FROM REF. 4, p. 24)	7
FIGURE 7: ILLUMINATION PATTERNS (MAIN LOBE) OF VARIOUS WIDTH AND TE ₀ MODE AMPLITUDE DISTRIBUTIONS.	8
FIGURE 8: CONTROL OF THE EFFECTIVE APERTURE OF A CYLINDRICAL LENS	10
FIGURE 9: COUPLING EFFICIENCY IN THE TE ₀ MODE AS A FUNCTION OF THE WIDTH BETWEEN THE FIRST NULLS OF THE ILLUMINATION FOR ILLUMINATION PATTERNS POSITIONED OPTIMALLY.	11
FIGURE 10: COUPLING EFFICIENCY IN THE TE ₀ MODE AS A FUNCTION OF TRANSVERSAL DISPLACEMENT OF THE ILLUMINATION FOR VARIOUS WIDTHS OF THE ILLUMINATION PATTERNS	12
FIGURE 11: CONVENTIONAL ILLUMINATION SYSTEM USING ONE CYLINDRICAL LENS.	13
FIGURE 12: GEOMETRY OF RECORDING FOR THE PROOF-OF-CONCEPTS HOLOGRAM.	15
FIGURE 13: GEOMETRY OF RECONSTRUCTION FOR THE PROOF-OF-CONCEPT HOLGORAM.	16
FIGURE 14: ASSESSMENT OF RELATIVE PHASE ERROR FOR A CYLINDRICAL LENS BY MEASURING THE DISPLACEMENT OF THE FRINGE PATTERN PRODUCED BY A PAIR OF SLITS AT THREE REPRESENTATIVE LOCATIONS.	17

LIST OF FIGURES (cont'd)

	<u>PAGE</u>
FIGURE 15: ANGLE OF INCIDENCE OF THE RAYS FOR THE MEASUREMENT RESULTS OF FIGURE L6.	18
FIGURE 16: POSITION OF THE FOCAL PLANE AS A FUNCTION OF THE ANGLE OF INCIDENCE OFF-AXIS OF THE RAYS FOR THE CYLINDRICAL LENS XZAR	19
FIGURE 17: GEOMETRY OF RECORDING FOR THE FIRST PROTOTYPE	21
FIGURE 18: GEOMETRY OF RECONSTRUCTION FOR THE FIRST PROTOTYPE.	22
FIGURE 19: TIME-INTEGRATING CORRELATOR USING INTEGRATED-OPTICS INTERACTION AND A HOLOGRAPHIC ILLUMINATION.	23
FIGURE 20: CORRELATION PRODUCED BY THE SYSTEM ILLUSTRATED IN FIGURE 19 AND THE FIRST PROTOTYPE OF THE ILLUMINATION SYSTEM.	24

1.0 INTRODUCTION

Spread spectrum signals are a crucial part of code division multiple access communication systems: they allow simultaneous utilization of the system by many users without mutual interference. Each user utilizes a personal, unique code that allows independent reception or transmission. Special processors, such as optical Time-Integrating Correlators (TIC), have the ability to provide certain information about spread-spectrum signals that may facilitate the initial synchronization of the user to his code.

A TIC can be built using bulk or integrated-optics acousto-optics devices. The approach using the bulk devices leads to interferometric systems that are large, made of many parts, difficult to stabilize and to package (see Fig. 1). With the approach using integrated-optics technology, the correlation module (see Fig. 2) itself is quite small but the associated illumination system involves a lot of equipment and occupies a large space (see Fig. 3) because of the requirement to produce two wide aperture beams offset in angle.

A possible approach to reduce the size of the illumination system is to use a modified Koster prism [1,2] to produce the two beams. Such prisms have to be custom built. Because of available resources, we chose a different approach: we decided to build a conventional illumination system and to make a holographic recording of the beams so produced. The hologram should produce, after reconstruction, the illumination necessary to operate the TIC and should allow a reduction in size (see Fig. 4) even more dramatic than with a Koster Prism. This Technical Note describes the development of a proof of concept and of a first prototype of a holographic illumination system for the TIC built by BNR.

2.0 REQUIREMENTS FOR THE ILLUMINATION SYSTEM

The correlator module illustrated in Fig. 2 was produced under a contract with BNR [3]. A bandwidth of 80 MHz centered at 400 MHz and an aperture of 25 mm were specified by DREO. The resulting Bragg angle between the two cylindrical beams is 6.2° . Direct coupling (sometime called "butt" or "end-fire" coupling), with a good efficiency, of two cylindrical He-Ne laser beams (wavelength: 633 nm) in the TE₀ mode is required over the 25 mm length of the TIC. The waveguide is made of indiffused Ti in LiNbO₃ crystal.

The amplitude of the field distribution of the TE₀ mode for a Ti:LiNbO₃ indiffused waveguide with a Gaussian profile [4] is illustrated in Fig. 6. Fig. 7 allows one to compare the profile of the TE₀ mode with the main lobe of the amplitude distribution produced by a uniformly illuminated perfect cylindrical lens whose effective aperture is varied to produce different widths of the main lobe. All the calculations for the amplitude distributions were normalized in such a way as to describe the situation encountered when a particular beam-expander illuminates a lens whose effective aperture is varied to produce different widths of the main lobe. The effective aperture of the lens is controlled by a variable slit positioned between the beam-expander and the lens (see Fig. 8). The total quantity of light in the main lobe then depends directly on the width of the effective aperture of the lens.

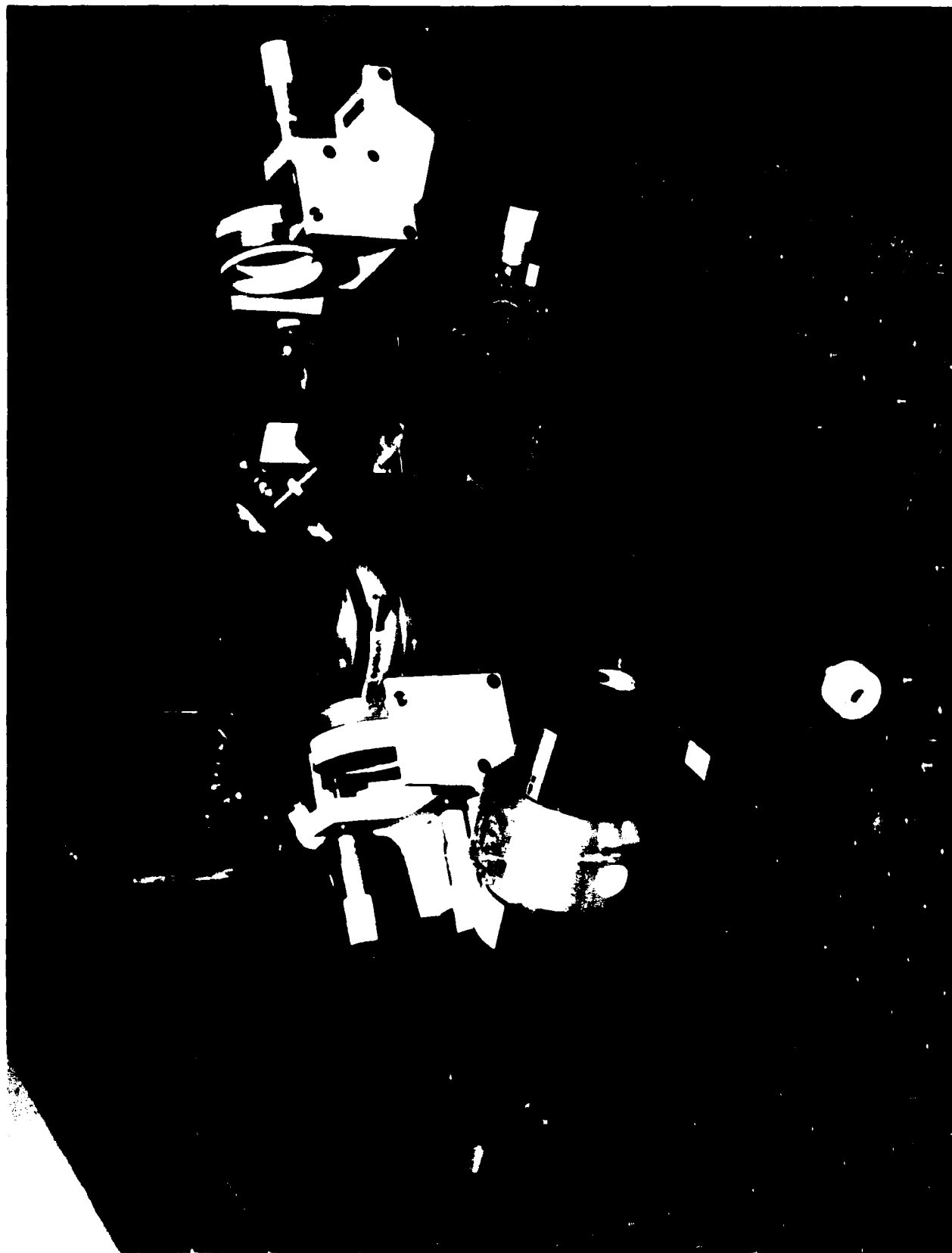

FIGURE 1 A TIME-INTEGRATING CORRELATOR USING BULK ACOUSTO-OPTICS INTERACTION

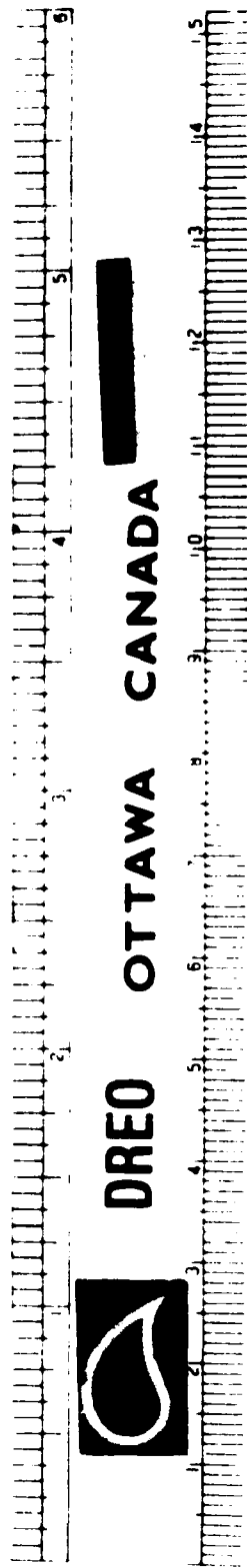
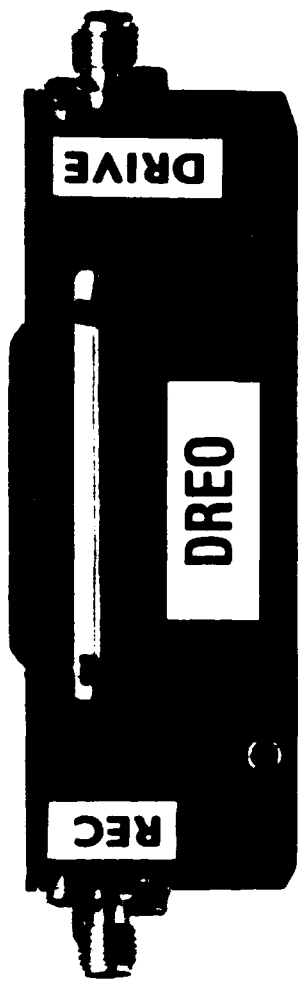

FIGURE 2 THE INTEGRATED-OPTICS CORRELATOR MODULE

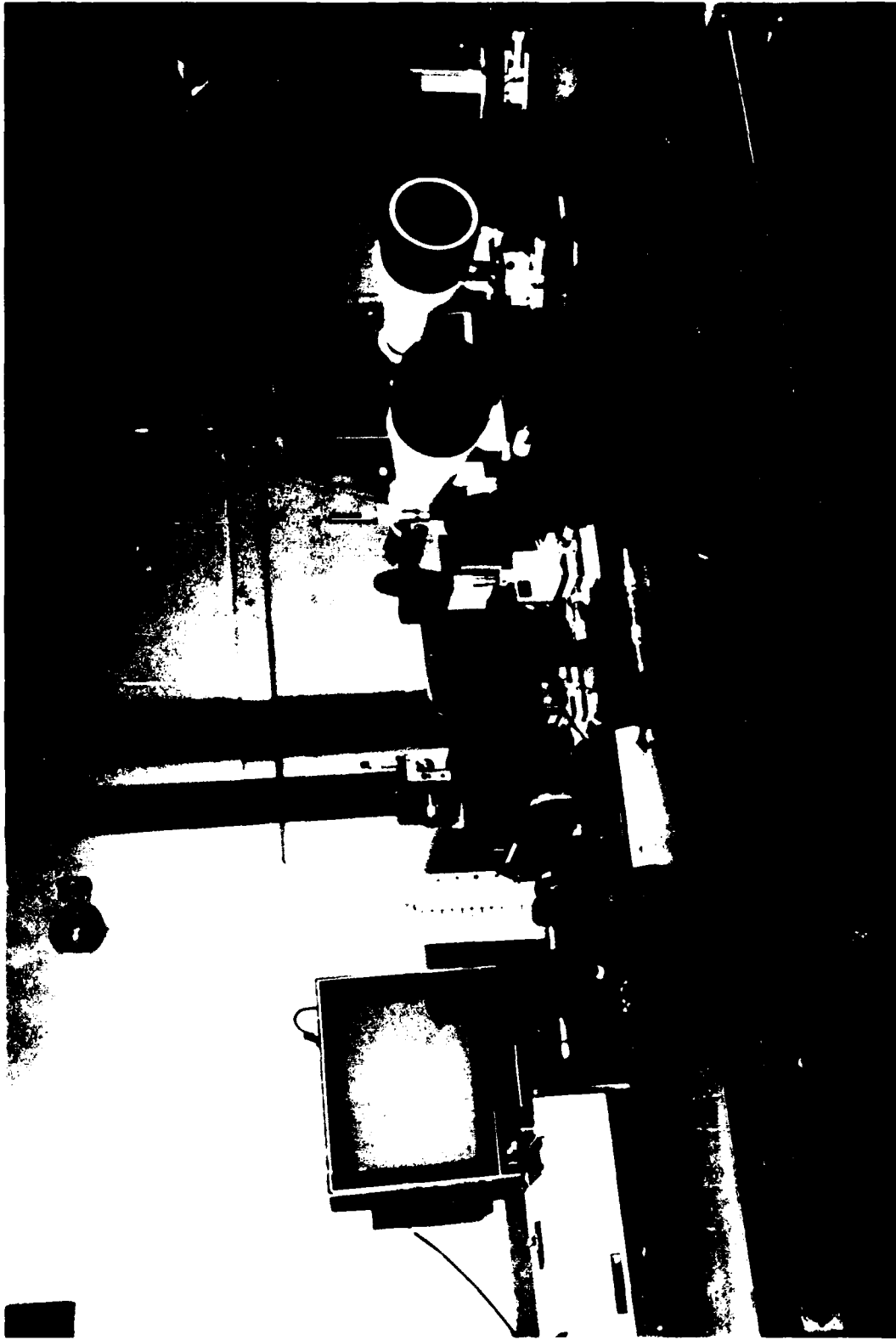

FIGURE 3 A TIME-INTEGRATING CORRELATOR USING INTEGRATED-OPTICS
ACOUSTO-OPTICS INTERACTION AND A CONVENTIONAL ILLUMINATION
SYSTEM

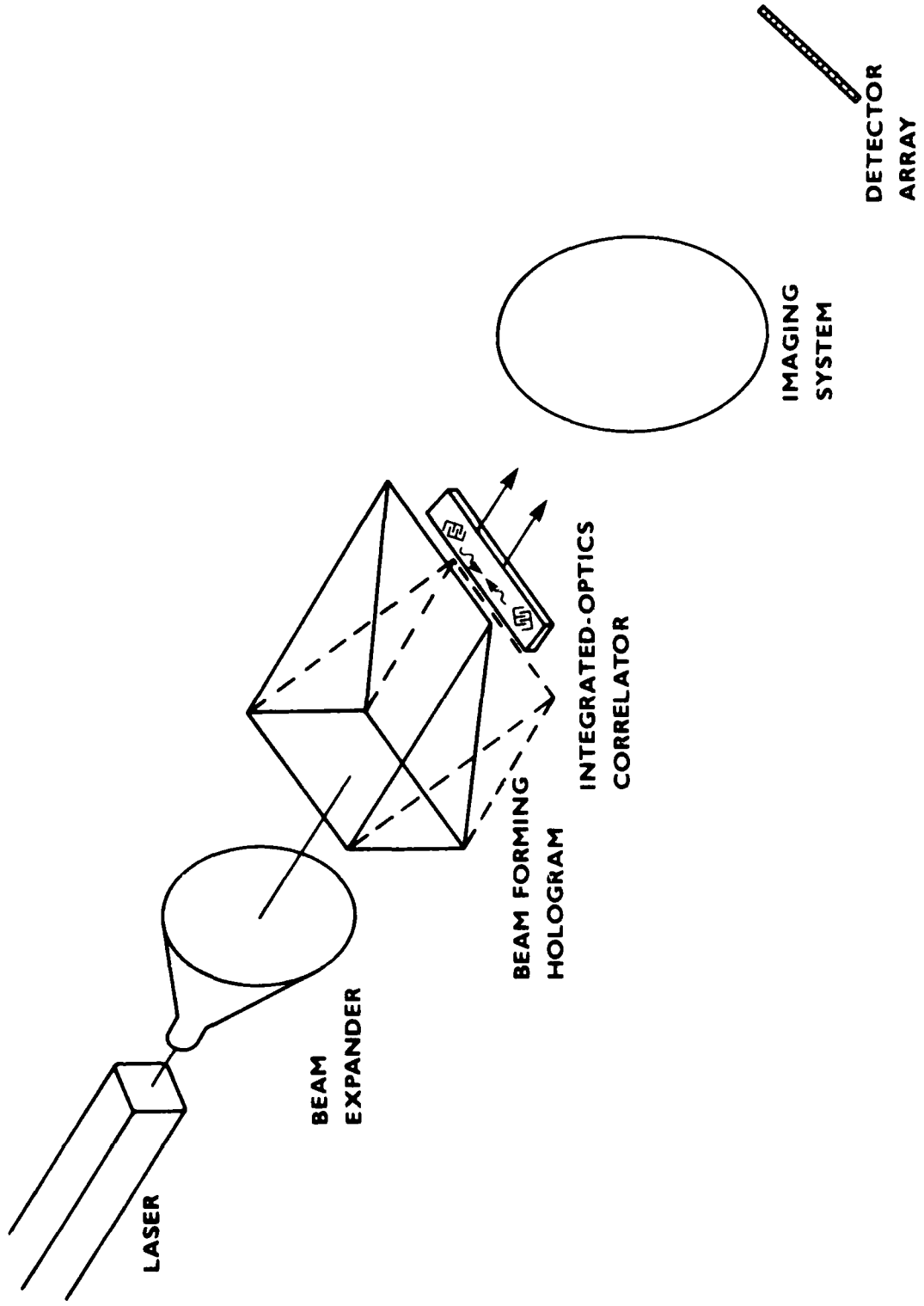

FIGURE 4: SCHEMATIC OF A TIME-INTEGRATING CORRELATOR USING INTEGRATED-OPTICS ILLUMINATION AND A HOLOGRAPHIC ILLUMINATION SYSTEM

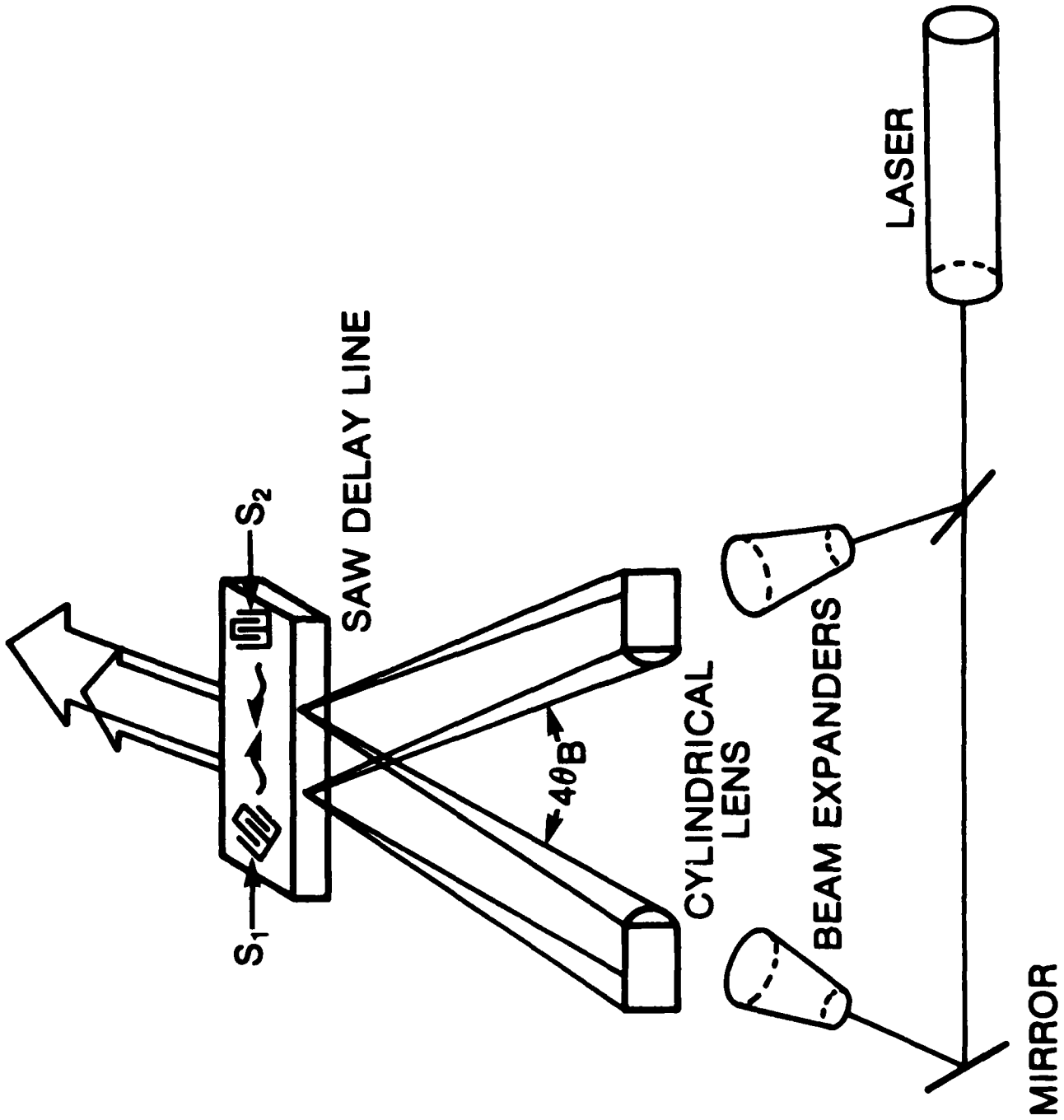

FIGURE 5: SCHEMATIC OF A CONVENTIONAL ILLUMINATION SYSTEM USING TWO LENSES

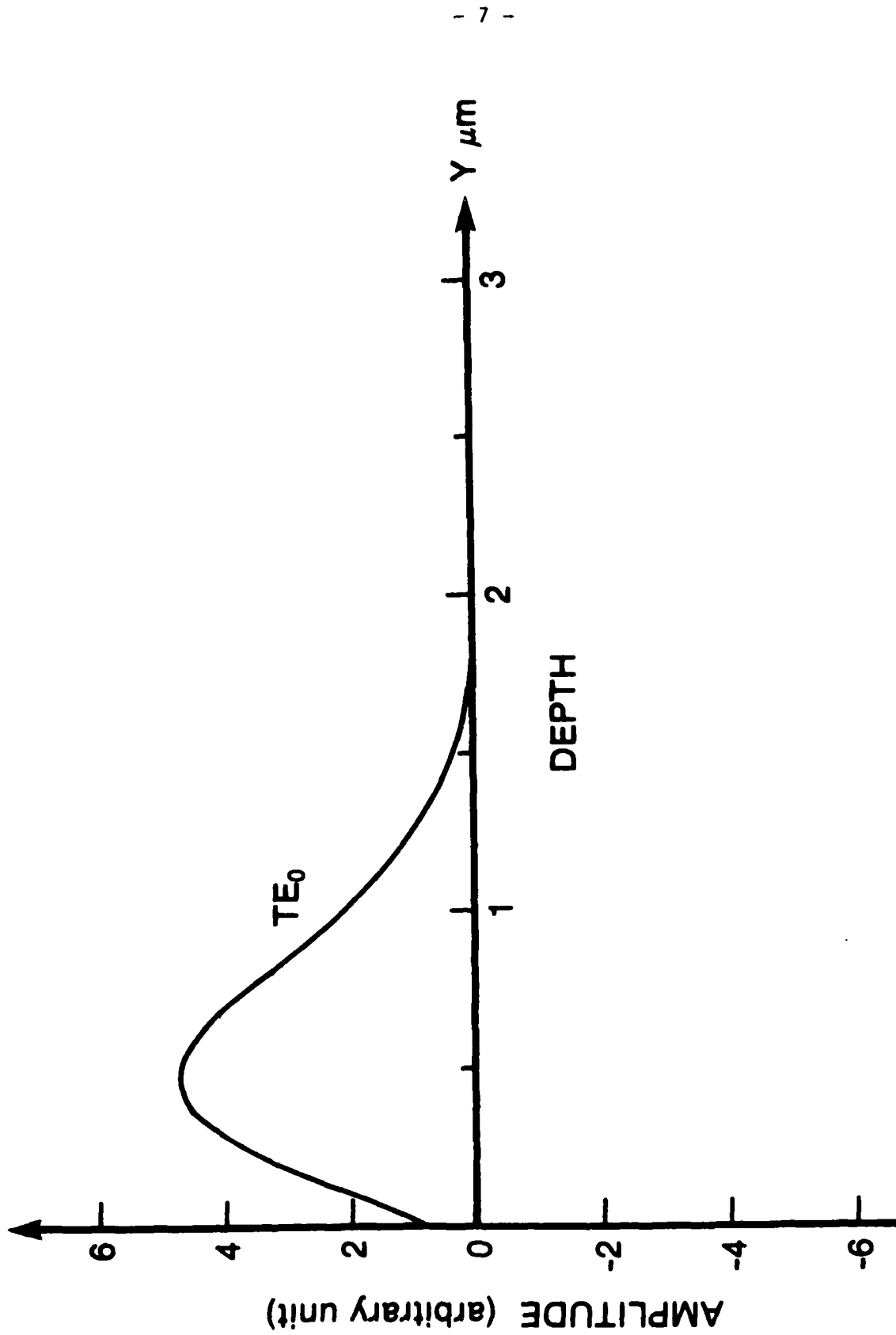

FIGURE 6: AMPLITUDE OF THE FIELD DISTRIBUTION OF THE TE₀ MODE FOR Ti:LiNbO₃ INDIFFUSED WAVEGUIDE (FROM REF 4, P. 24)

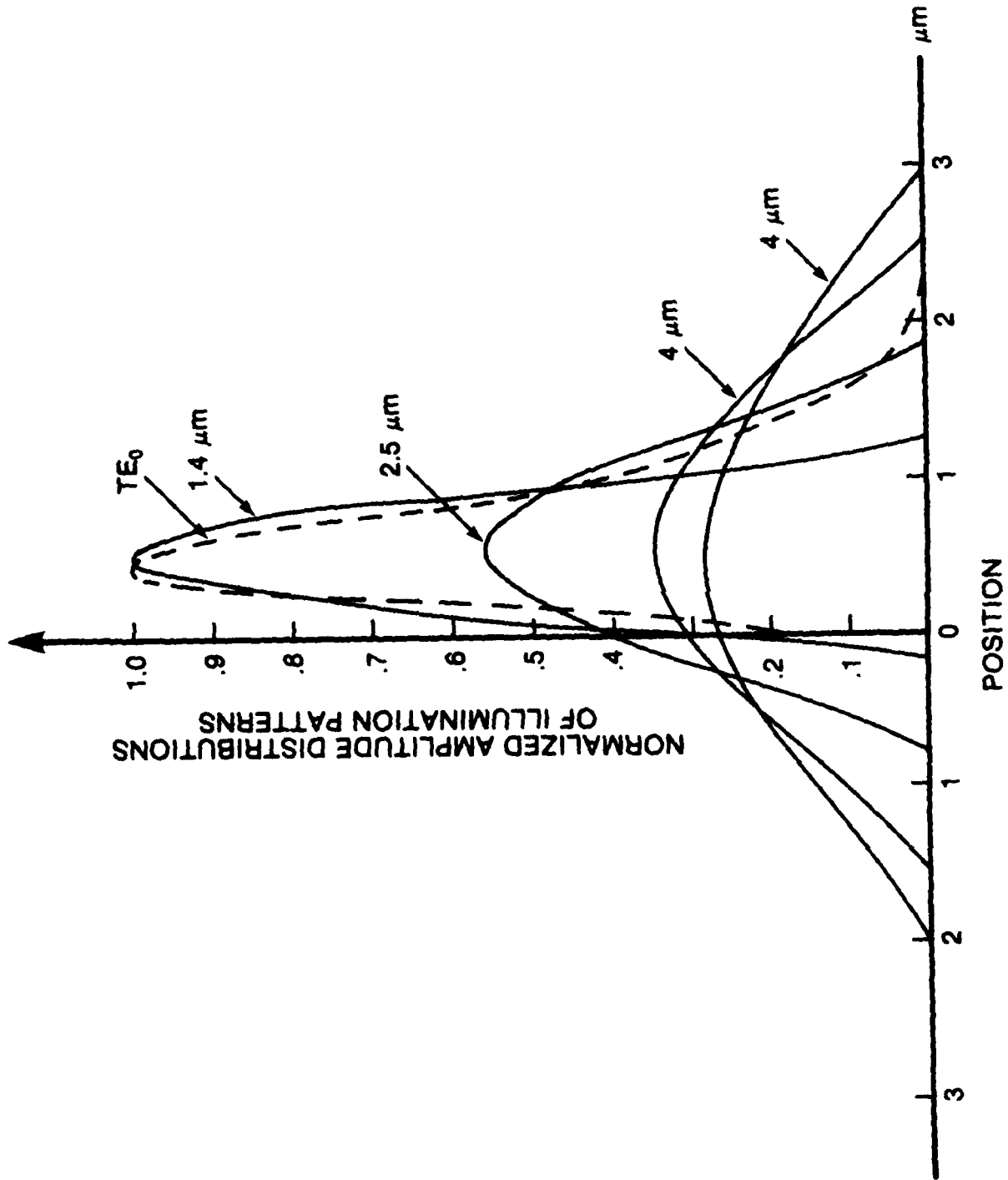

FIGURE 7 ILLUMINATION PATTERNS (MAIN LOBE) OF VARIOUS WIDTH AND TE_0 MODE AMPLITUDE DISTRIBUTIONS

From Ref. 5, p. 89, direct focussing of a laser beam is the simplest method of coupling light into a waveguide. In that case, the coupling efficiency η is given by the overlap integral of the amplitude distribution of the input laser beam $A(x)$ and the amplitude distribution of the mode in the waveguide $B(x)$. $A^*(x)$ are the complex conjugate of $A(x)$ and $B(x)$.

$$\eta = \frac{\left[\int A(x) B^*(x) dx \right]^2}{\left[\int A(x) A^*(x) dx \right] \left[\int B(x) B^*(x) dx \right]} \quad (1)$$

One can deduce from Eq. 1, that a good coupling efficiency is obtained when $A(x)$ and $B(x)$ are similar. Indeed, a coupling efficiency of one is obtained if $A(x)$ is equal to $B(x)$. The values of η associated with the coupling in the TE_0 mode of the various amplitude distributions of Fig. 7 were calculated as a function of the width between the first nulls of the light distribution (see Fig. 9). A coupling efficiency of more than 50% was obtained for beam width between .3 μm and 2.5 μm . However, it is likely that the illumination will not overlap the waveguide perfectly over its whole 25 mm length. This may arise because the waveguide and its substrate are not perfectly flat or because the illumination is slightly curved or because of a alignment errors. Fig. 10 shows the coupling efficiency η when the waveguide and the illumination are not perfectly aligned. One can notice that narrow illumination patterns produce high coupling efficiency that drop quickly when the illumination is not perfectly aligned with the waveguide. On the other hand, wide illumination patterns lead to poor coupling efficiencies that are quite insensitive to position errors. From the curves of Fig. 10, a 3 μm wide illumination pattern seems to be a good compromise between good coupling efficiency and alignment sensitivity.

3.0 CONVENTIONAL ILLUMINATION SYSTEM FOR A TIC

Previous approaches to the design of conventional illumination systems of integrated-optics TIC were based on the utilization of two converging beams focussed by two lenses onto the 25 mm aperture of the waveguide (see Fig. 5). The angle between the two beams is 6.2° in our case. However, we decided to focus the two beams with a single, larger lens (see Fig. 11). That method provides automatic superposition of the focal lines if the two incident beams are aligned and thus avoids the situation where errors in the alignment of the beams are compensated by errors in the alignment of the lenses. The lens has to be one focal length away from the waveguide. It has also to be large enough to let the two illumination beams through and still provides a 25 mm overlap of the illumination beams at the waveguide. In order to produce a 3 μm wide focal line, the lens should have an f number of no more than $f/2.5$ and be diffraction limited.

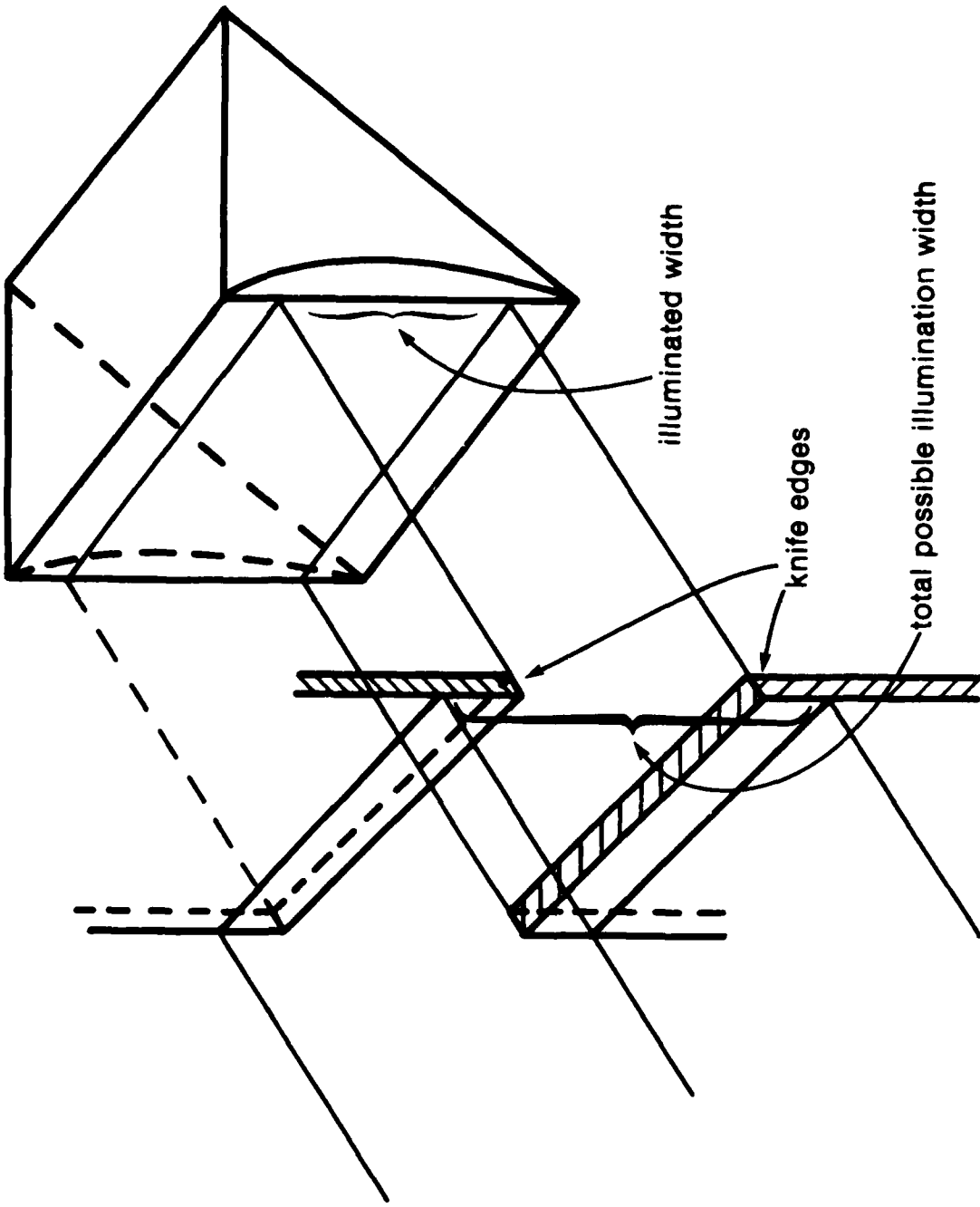

FIGURE 8: CONTROL OF THE EFFECTIVE APERTURE OF A CYLINDRICAL LENS

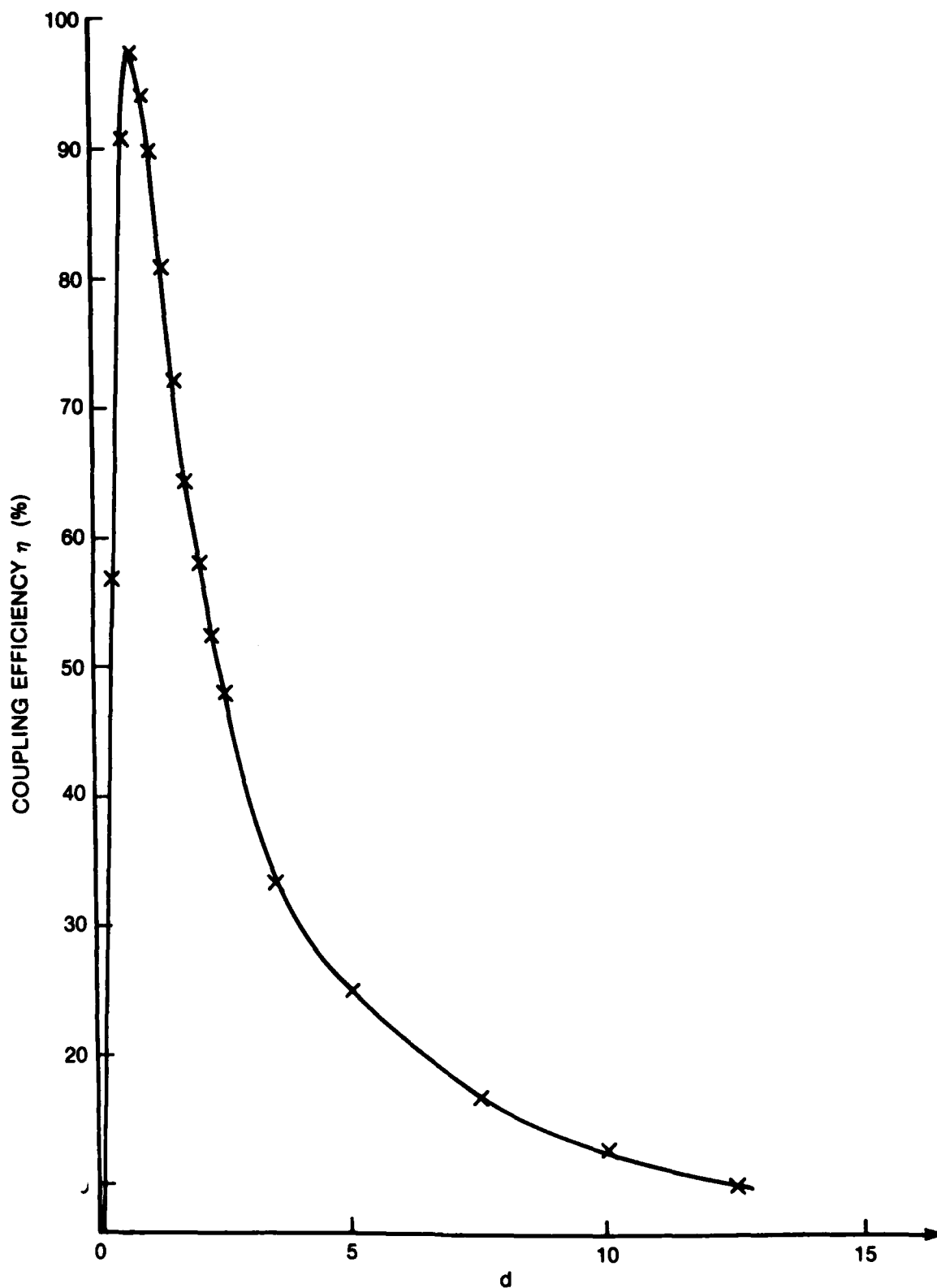

FIGURE 9: COUPLING EFFICIENCY IN THE TE₀ MODE AS A FUNCTION OF THE WIDTH BETWEEN THE FIRST NULLS OF THE ILLUMINATION FOR ILLUMINATION PATTERNS POSITIONED OPTIMALLY

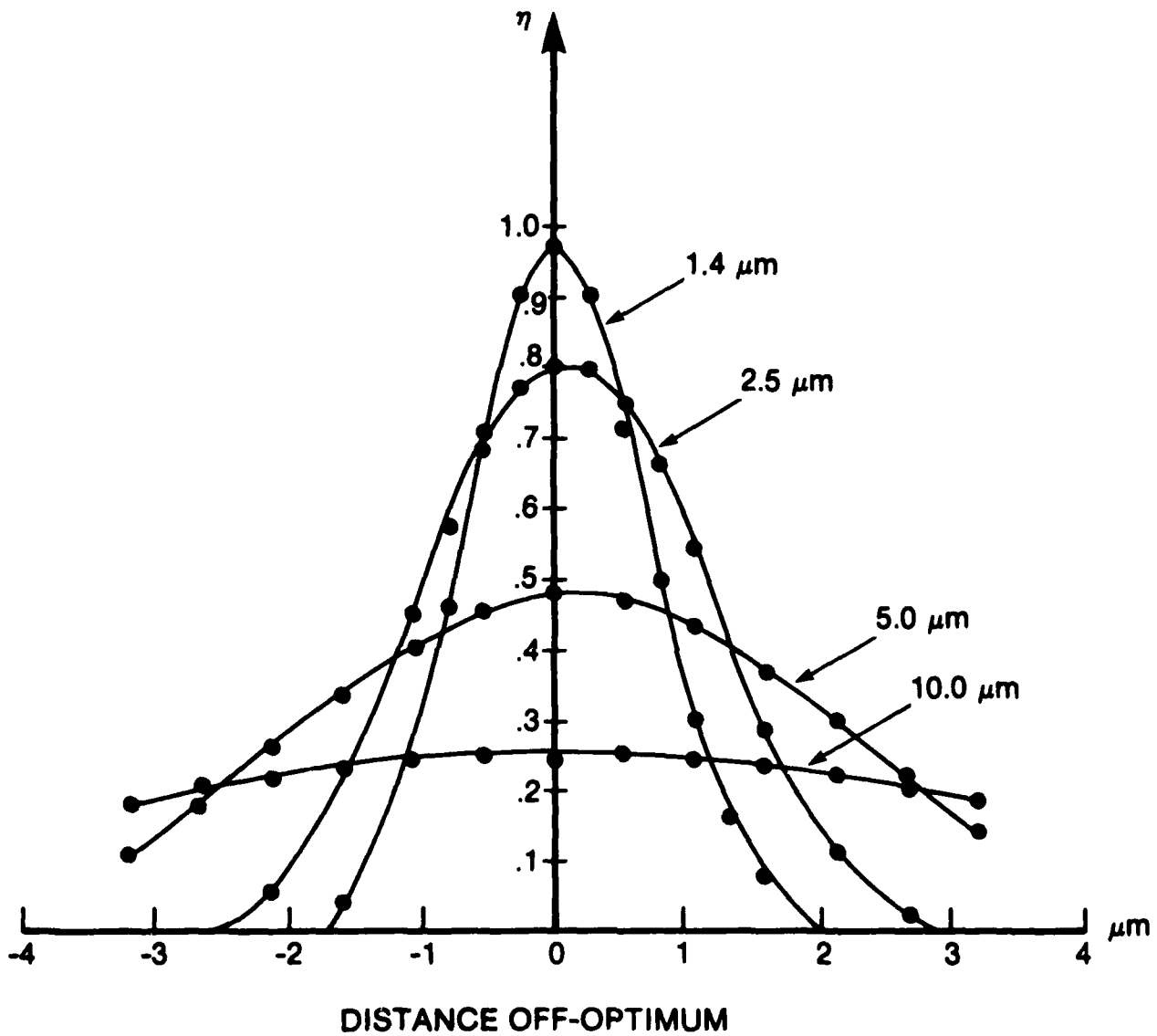

FIGURE 10: COUPLING EFFICIENCY IN THE TE_{00} MODE AS A FUNCTION OF TRANSVERSAL DISPLACEMENT OF THE ILLUMINATION FOR VARIOUS WIDTHS OF THE ILLUMINATION PATTERNS

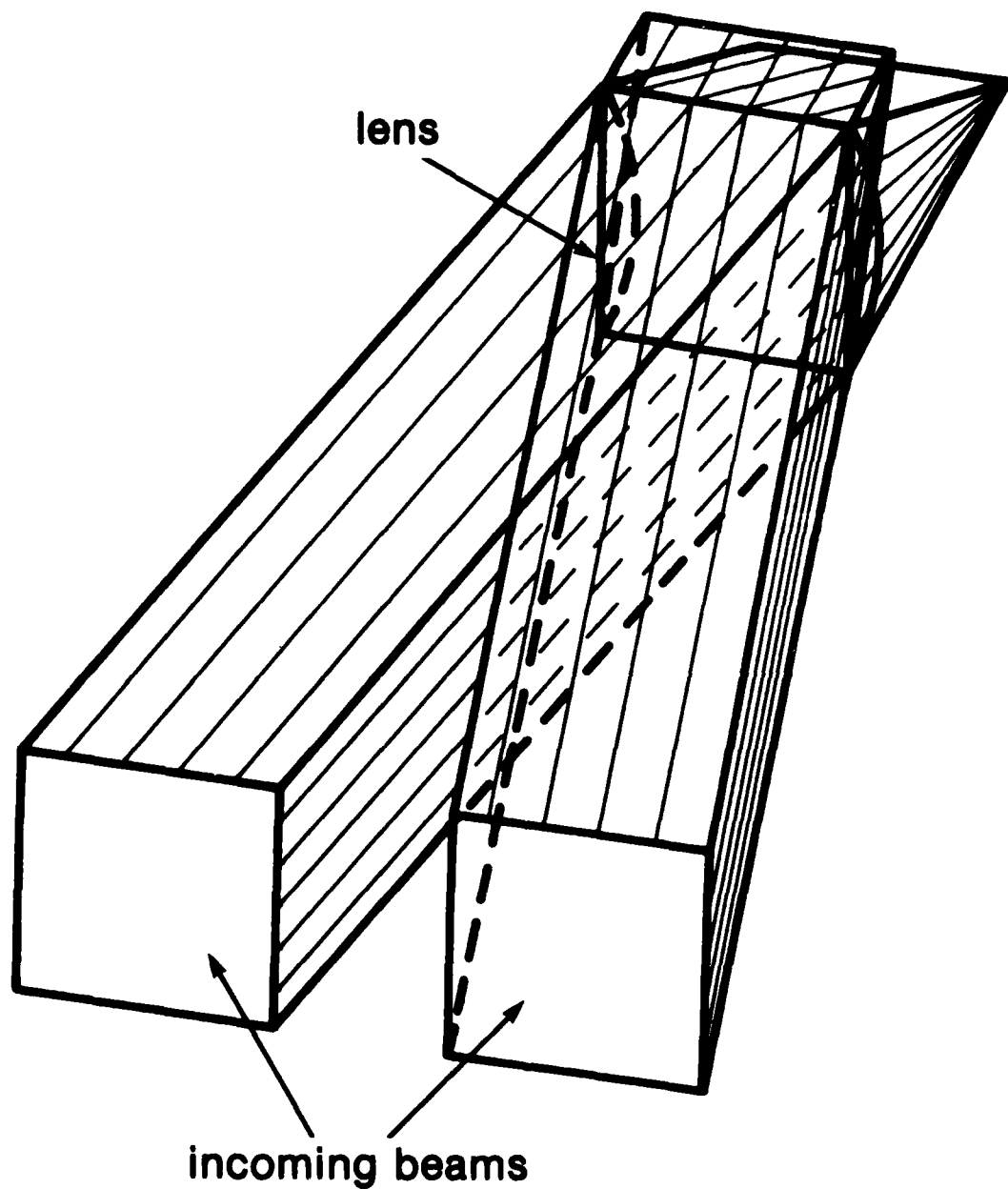

FIGURE 11: CONVENTIONAL ILLUMINATION SYSTEM USING ONE CYLINDRICAL LENS

4.0 PROOF OF CONCEPT HOLOGRAM

The feasibility of the concept of a holographic illumination system for an integrated-optics TIC was demonstrated by a series of experiments performed from January 1986 to September 1987. First, a hologram was recorded using the geometry of Fig. 12. The cylindrical lens utilized in the set-up had a 50 mm x 50 mm aperture and a focal length of 300 mm but it was not diffraction limited: the width of the focal line was of the order of 20 μm instead of the expected 7.6 μm . Because the f number of the lens was only f/8, the angle between the two beams had to be set at 5.1° in order to obtain a 25 mm superposition of the beams in the focal plane. The reference beam was a plane wave at 15° from the normal to the plate. The transmission holograms were recorded on Kodak 649F emulsion on micro-flat plates. The holograms were exposed, developed and bleached using the procedure published by Collier et al. [6], p. 289-292.

The hologram was reconstructed (see Fig. 13) and evaluated. It was found that the two beams had 5.2° between the two beams instead of the original 5.1°. That effect was attributed to emulsion shrinkage and changes in the index of refraction of the emulsion. It was also found that higher order images were present, thus contributing to a decrease in diffraction efficiency. A possible solution to that problem is to increase the angle of the reference beam. The width of the line produced by the hologram was similar to the width of the line produced by the lens. Finally, the two beams were coupled to a waveguide of Ti:LiNbO₃ provided by BNR for testing purposes. Although the coupling of efficiency was low because of the large size of the focal line, no particular difficulty was encountered.

5.0 SELECTION AND TESTING OF THE LENS

A lens should have a numerical aperture of at most f/2.5 in order to produce a diffraction pattern with a width of 3 μm between the first nulls. The quality of the manufacture of the lens has to be sufficient to avoid blurring of the focal line by aberrations and to produce a line of uniform quality, straight to $\pm 5 \mu\text{m}$. A diffraction limited, f/2.5 cylindrical lens manufactured by Optics Plus Inc. was selected. The aperture of the lens is a 50 mm x 50 mm square, so that two illumination beams can be generated. It has a focal length of 125 mm. The manufacturer specifies that the phase error across the whole aperture of the wavefront is not more than $\lambda/4$.

Upon delivery, the phase error distribution of the lens was tested at three representative locations (see Fig. 14) by a technique described in Ref. 7 and previously utilized at DREO [8]. A slight error of $\lambda/15$ was found in a small area, in one of the corners of the lens. Although the precision of the phase error measurement was $\lambda/30$, it is possible that the $\lambda/15$ error was produced by a phase error in the illumination rather than by the lens. No effort was made to locate the origin of that very small error, the performance of the lens being already more than satisfactory.

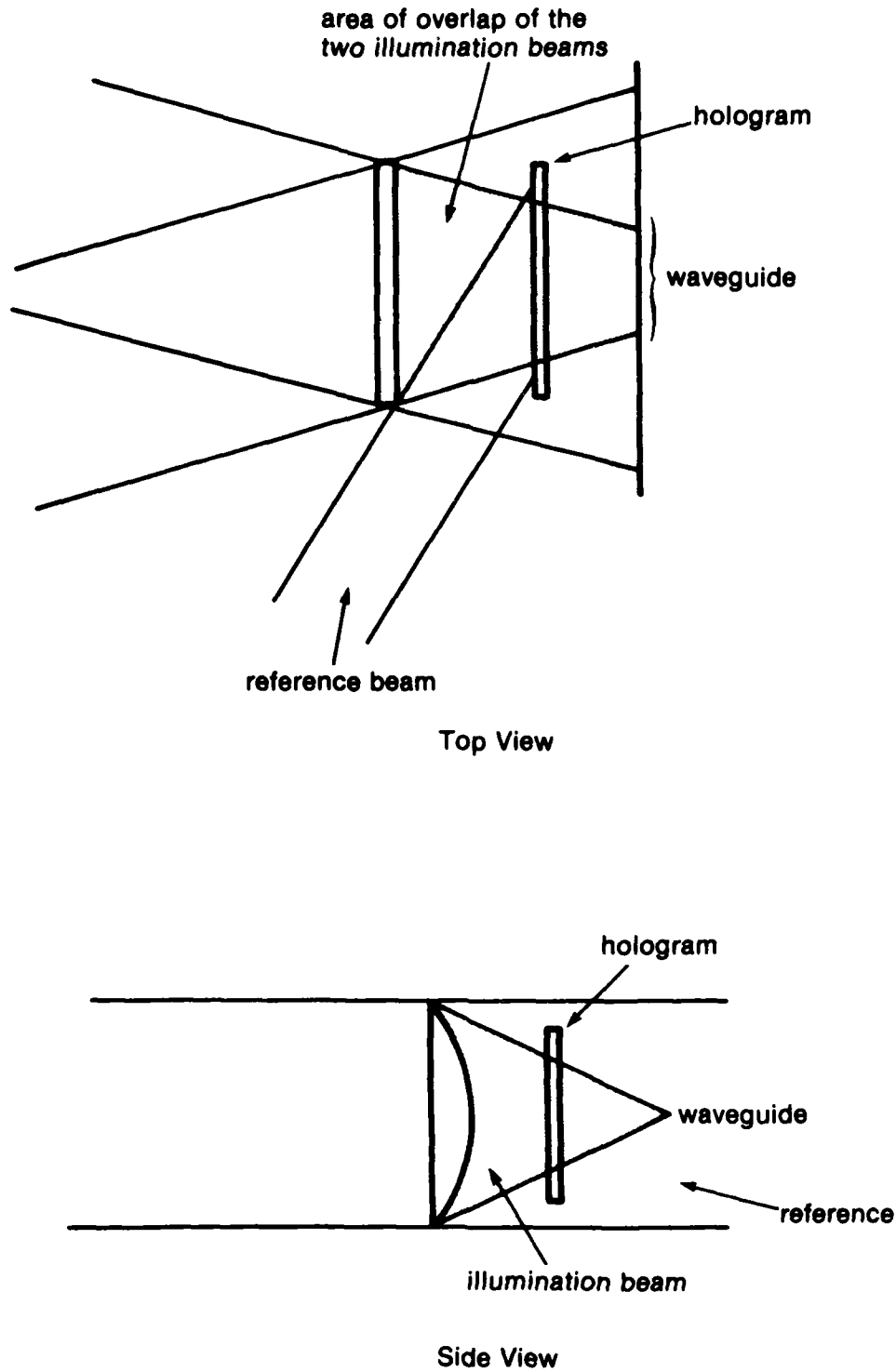

FIGURE 12: GEOMETRY OF RECORDING FOR THE PROOF-OF-CONCEPT HOLOGRAM

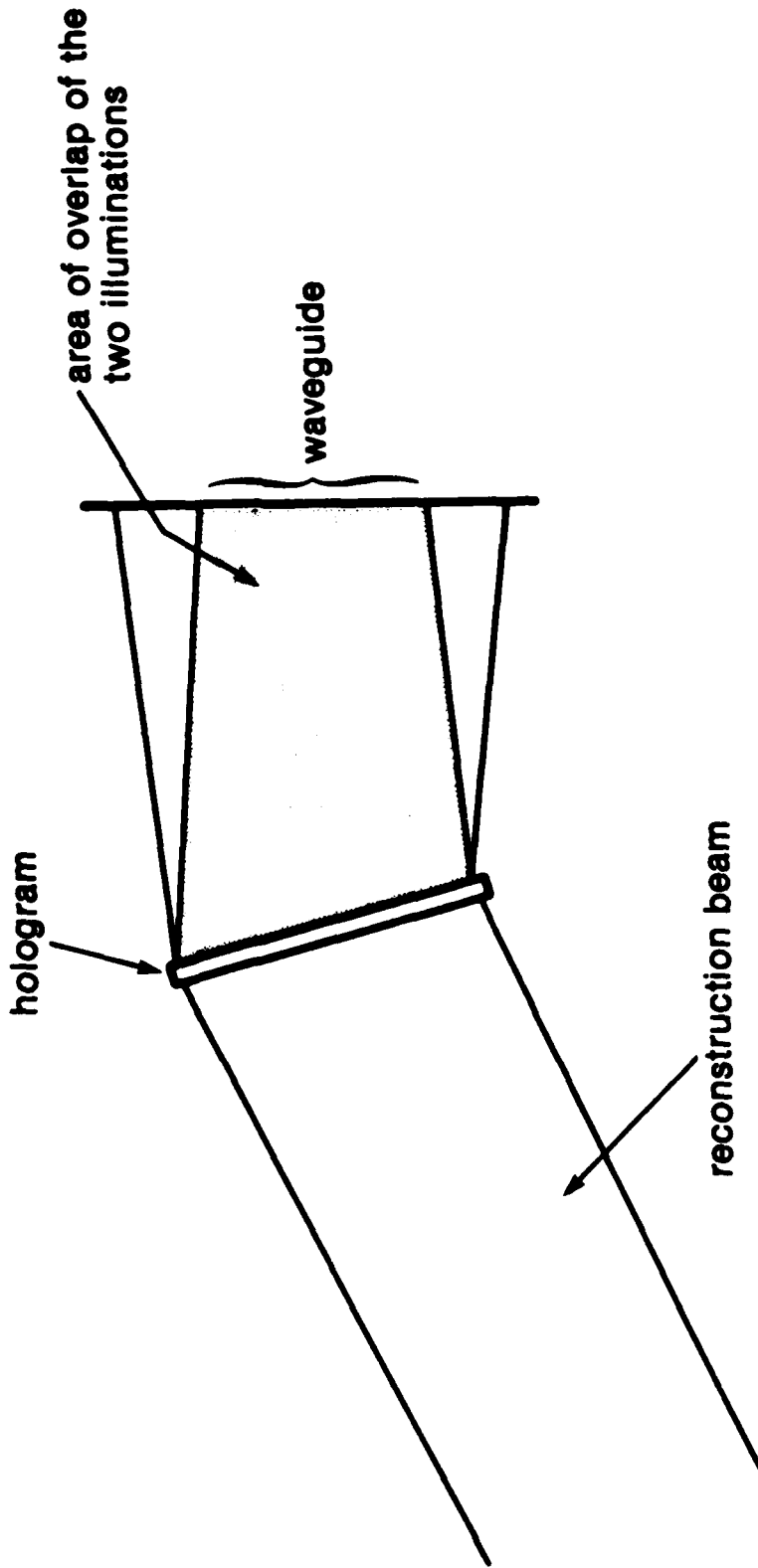

FIGURE 13: GEOMETRY OF RECONSTRUCTION FOR THE PROOF-OF-CONCEPT HOLOGRAM

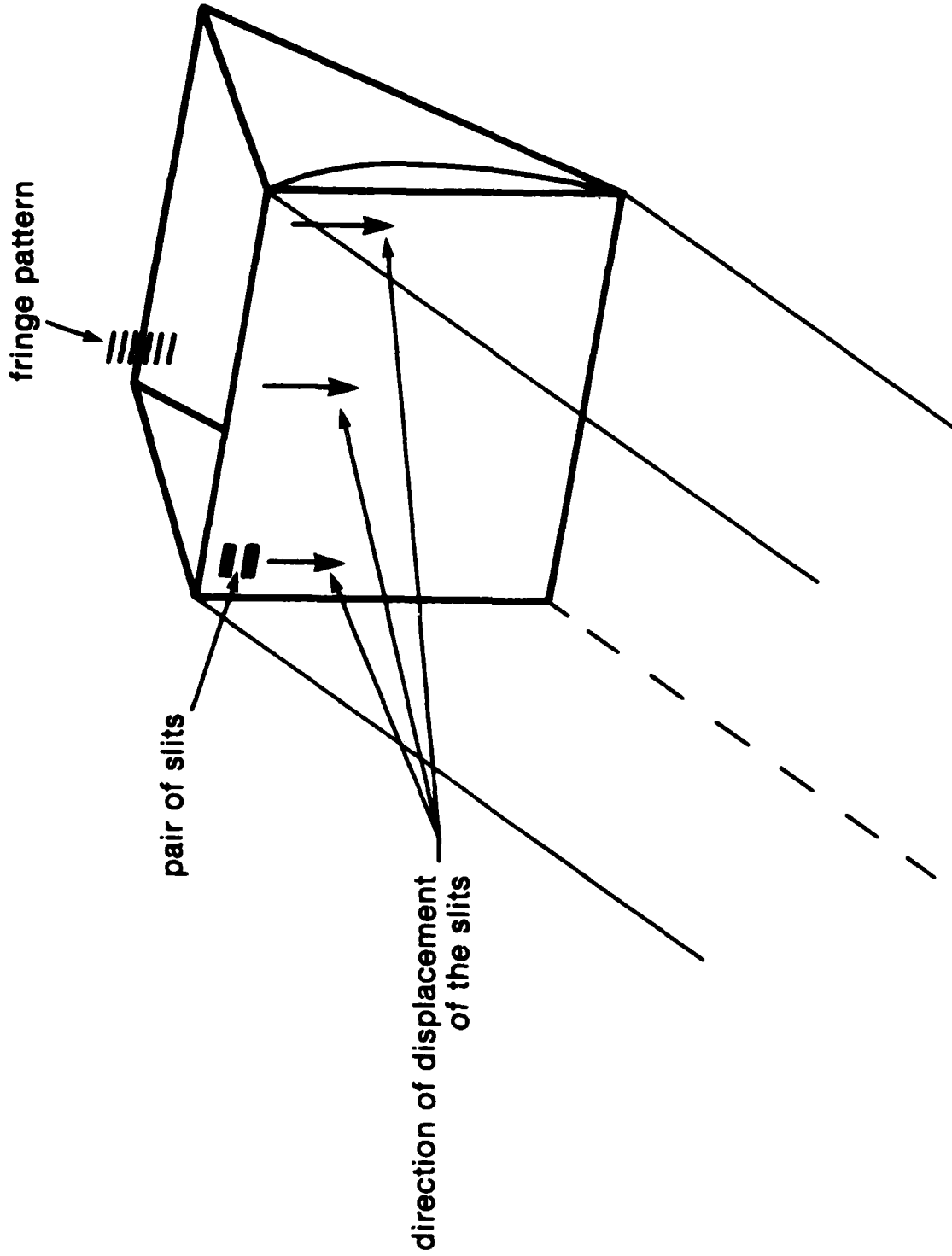

FIGURE 14: ASSESSMENT OF RELATIVE PHASE ERROR FOR A CYLINDRICAL LENS BY MEASURING THE DISPLACEMENT OF THE FRINGE PATTERN PRODUCED BY A PAIR OF SLITS AT THREE REPRESENTATIVE LOCATIONS

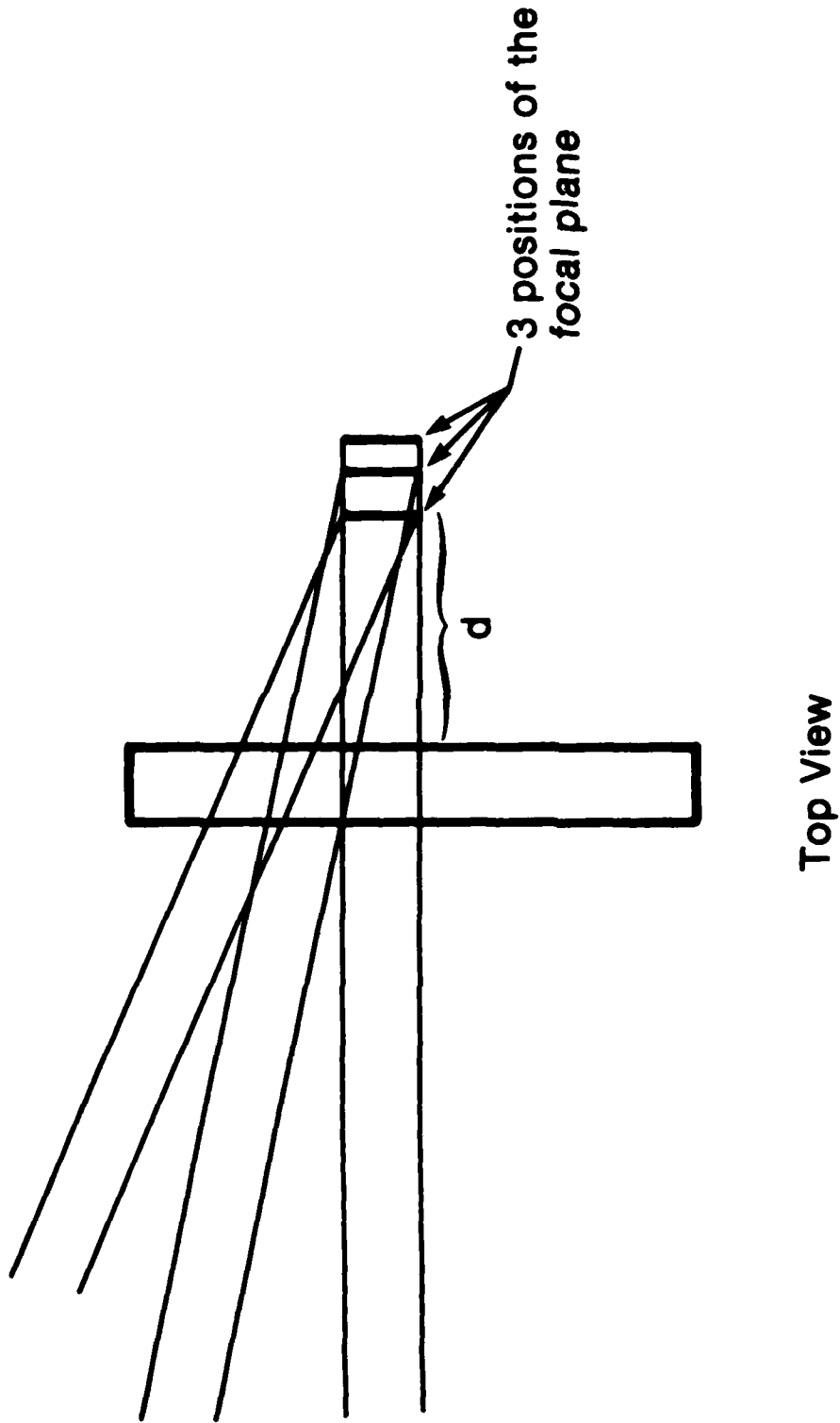
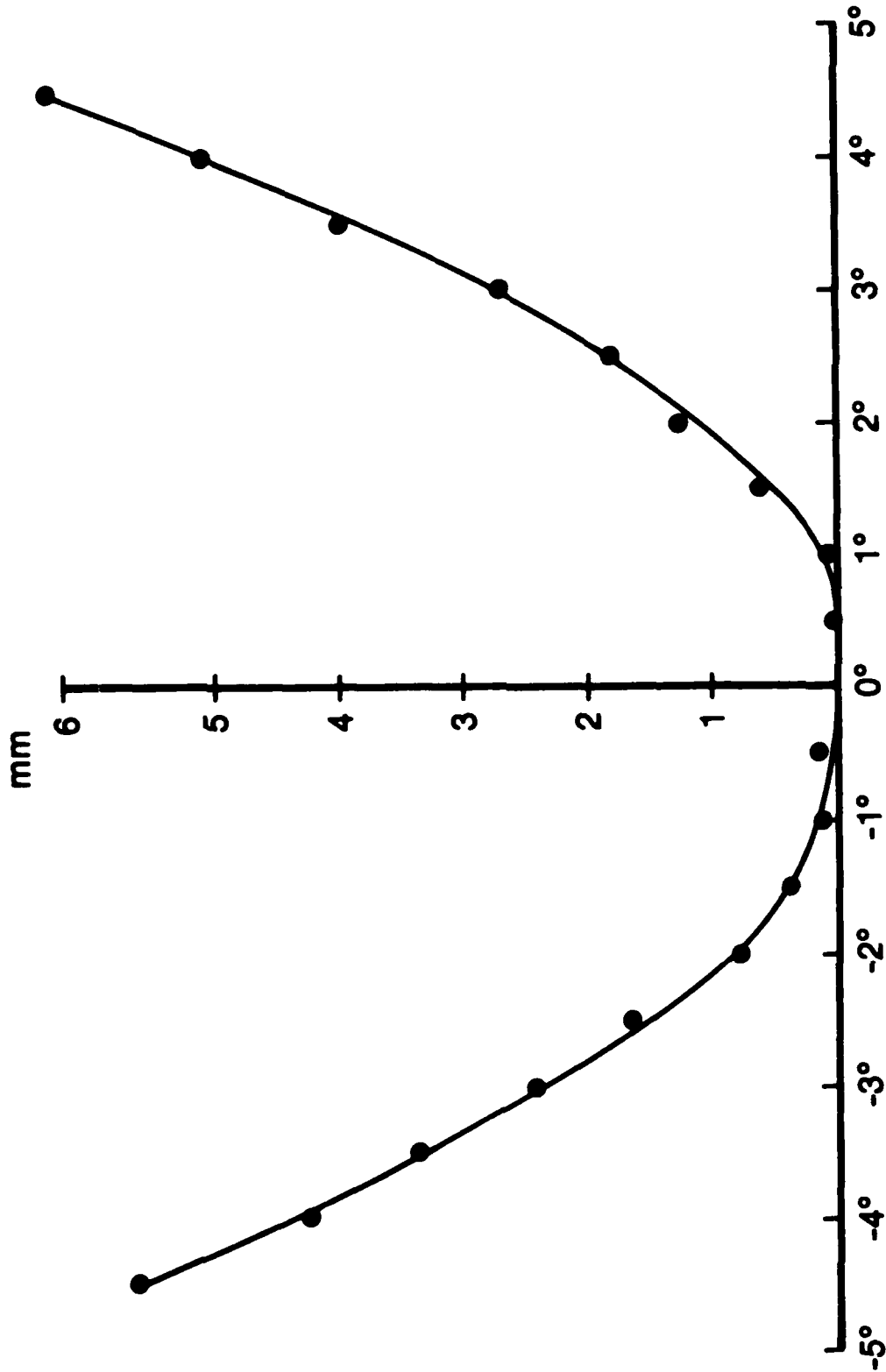

FIGURE 15: ANGLE OF INCIDENCE OF THE RAYS FOR THE MEASUREMENT RESULTS OF FIGURE 16



ANGLE OF INCIDENCE OFF-AXIS OF THE RAYS

FIGURE 16: POSITION OF THE FOCAL PLANE AS A FUNCTION OF THE ANGLE OF INCIDENCE OFF-AXIS OF THE RAYS FOR THE CYLINDRICAL LENS XZAR

The distance d between the lens and the focal line as a function of the angle of incidence θ of the ray (see Fig. 15) was studied experimentally. The results are illustrated in Fig. 16 and indicate that the position of the focal plane varies considerably when the angle of incidence is greater than 1° . The curve observed in Fig. 16 is, within the experimental error, symmetrical. The characteristics of the lens illustrated in Fig. 16 are a cause of difficulties in the adjustment of the illumination system for the TIC. The angle between the two beams could be 6.2° and at the Bragg angle with the TIC, but, if the beams are not symmetrical relative to the normal to the lens, the two beams will not focus in the same plane and thus simultaneous coupling of both beams in the waveguide, with good efficiency, will not be possible.

6.0 CONSTRUCTION OF A FIRST PROTOTYPE HOLOGRAM

A first prototype of the holographic illumination system for the TIC constructed by BNR was recorded using the set-up illustrated in Fig. 3. The two illumination beams were carefully coupled into the waveguide and adjusted to the Bragg angle at the center frequency of the correlator (400 MHz). A transmission hologram was then recorded with the normal to the plate being approximately the bisector of the angle between the reference beam and the two object beams (see Fig. 17). That particular geometry is recommended (9) to prevent discrepancies between the recording and reconstruction geometry caused by the shrinkage and the decrease of the index of refraction of the emulsion. The hologram was developed and bleached with the same process as the proof of concept hologram. After processing, the hologram was put back in the holder and reconstructed (see Fig. 18) with the laser beam that was used as a reference at the recording stage. Then the two object beams were let through and their registration with the reconstructed beams, on the wall, 10 feet away, was perfect. That last point is particularly important because the two object beams have been adjusted to the Bragg angle for efficient acousto-optic interaction. If the two reconstructed beams were not exactly at the same angle than the object beams, the efficiency would be diminished or even non-existent. The diffraction efficiency of the hologram was 22%.

However, a few technical problems were identified after further evaluation. The two focal lines produced by the hologram were neither focussing in the same plane nor focussing at the same height. The angle between the reference beam and the object beams was also too small: higher order images were visible. Those three problems are easy to overcome by slight modification and better adjustment of the set-up utilized to record the hologram. Unfortunately, the power supply of the laser was destroyed by a fire the day after the first recording and it was impossible to produce a better hologram at that time.

Nevertheless, this first hologram was used to illuminate the TIC (see Fig. 19) and, despite its shortcomings, produced the results illustrated in Fig. 20. A RF power of 100 mW on each transducer and a laser power of 18 mW were producing enough light to saturate the detector array. Under these conditions, the observed correlation signal was somewhat noisier than the signal produced by the TIC made of glass bulk Bragg cell [10], but the signal was more stable.

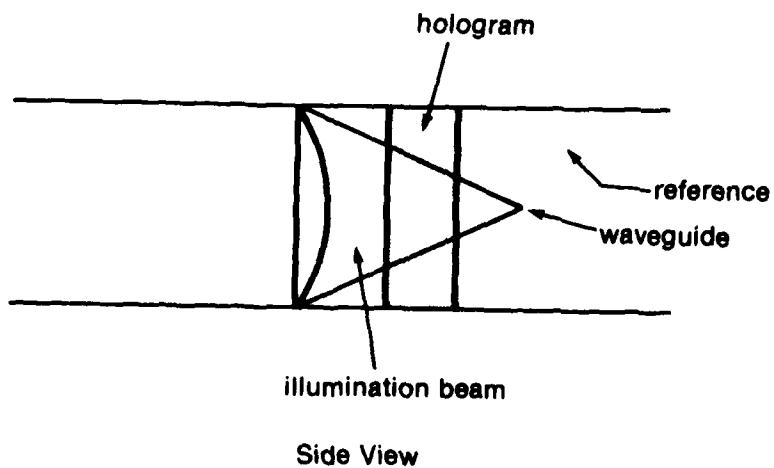
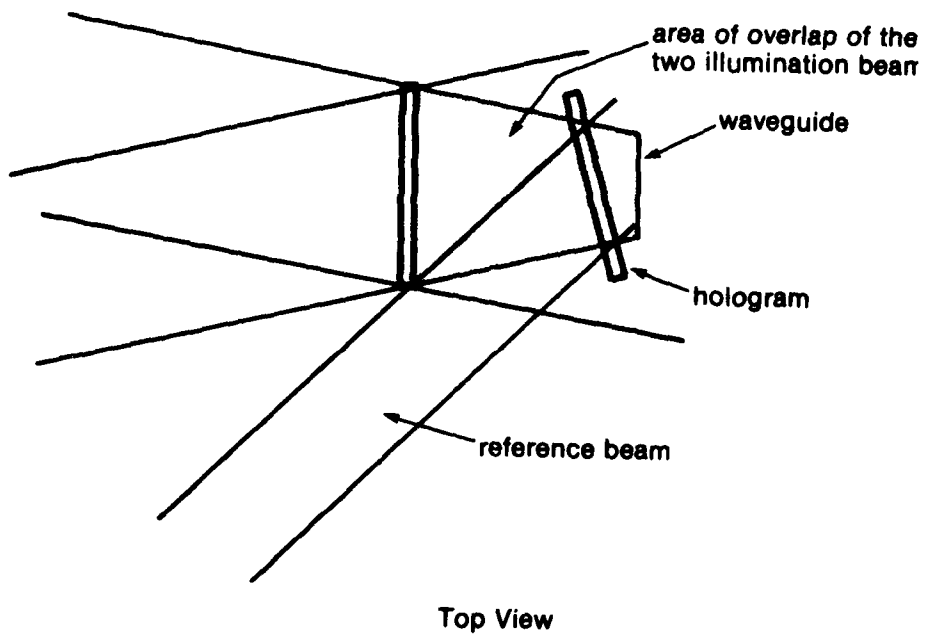

FIGURE 17: GEOMETRY OF RECORDING FOR THE FIRST PROTOTYPE

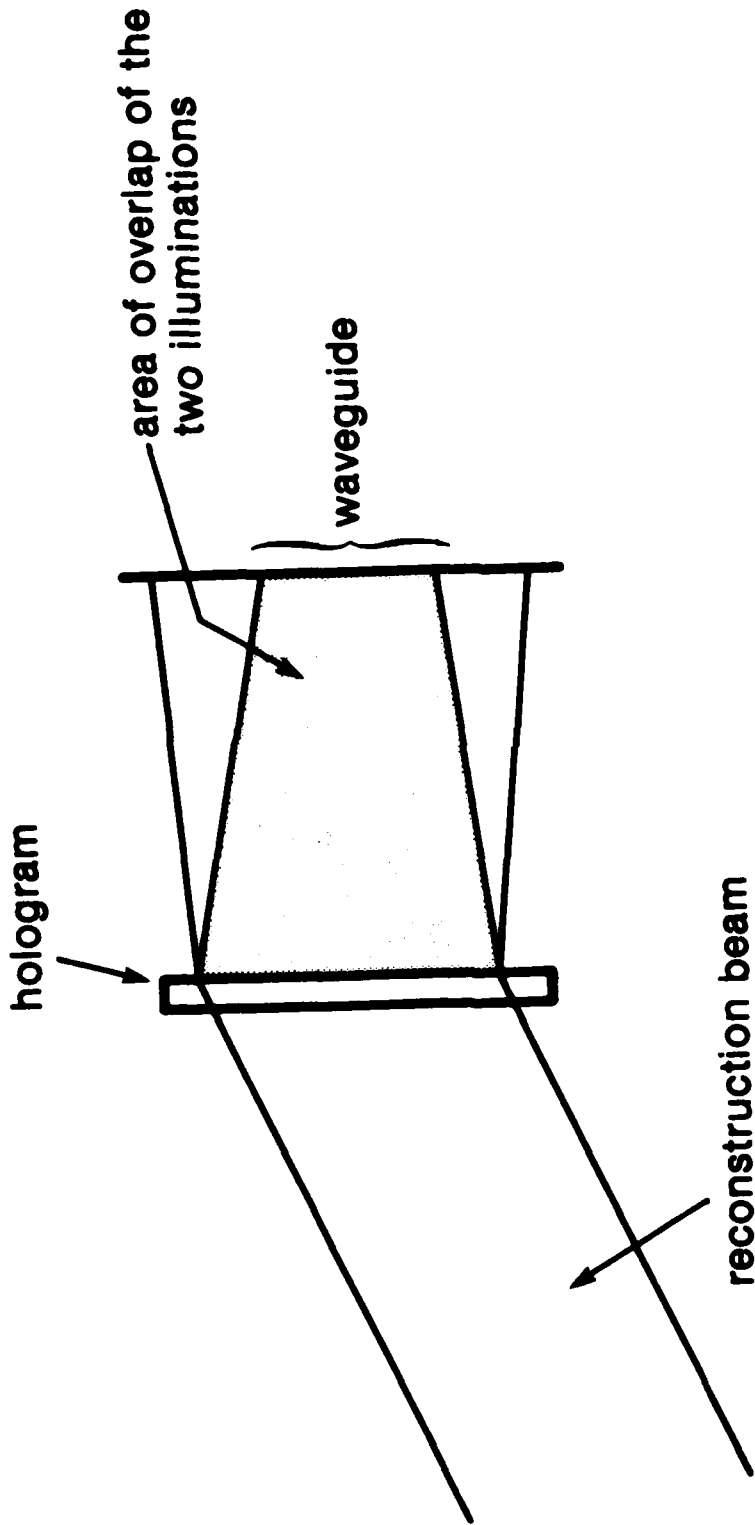

FIGURE 18: GEOMETRY OF RECONSTRUCTION FOR THE FIRST PROTOTYPE

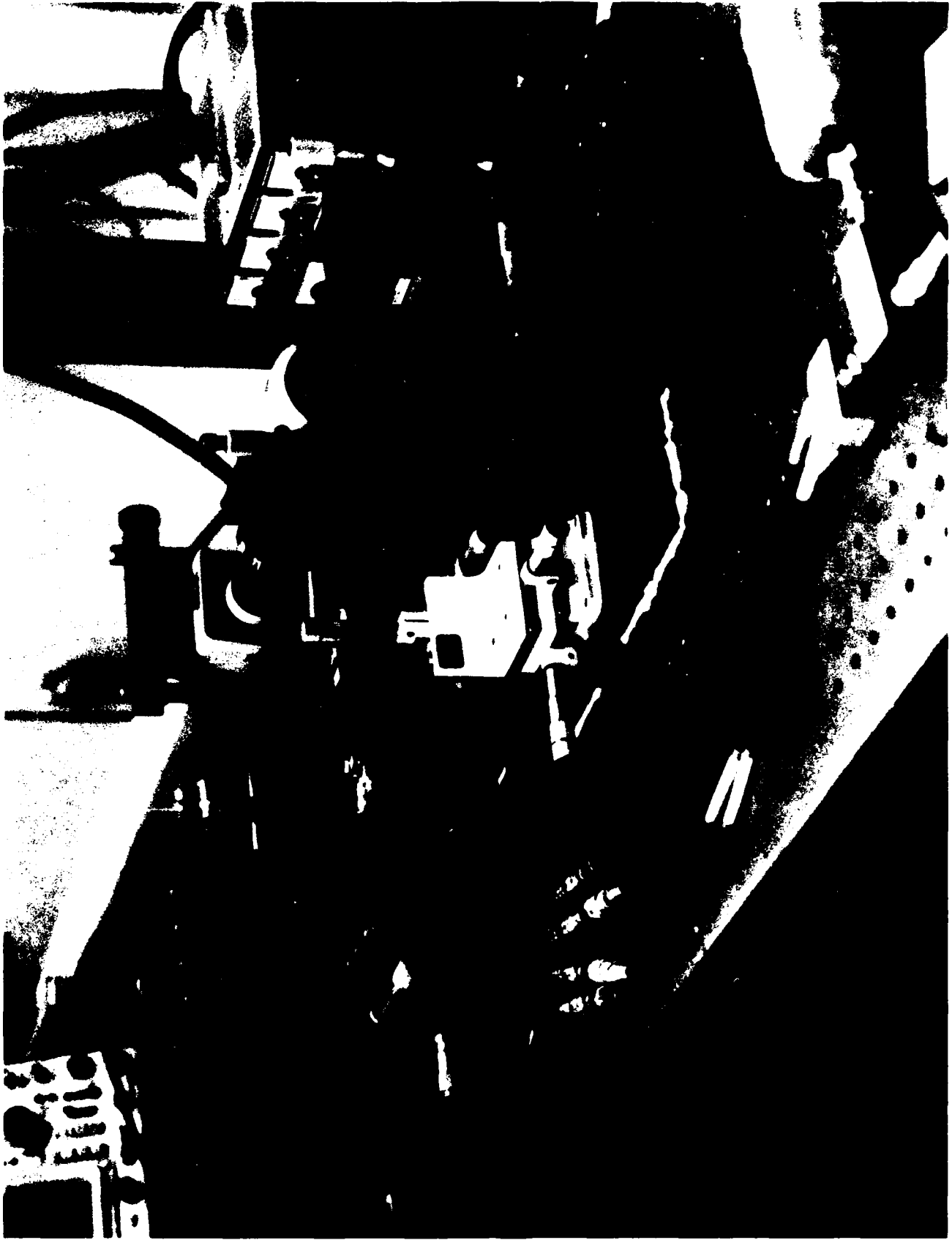

FIGURE 19 TIME-INTEGRATING CORRELATOR USING INTEGRATED-OPTICS
INTERACTION AND A HOLOGRAPHIC ILLUMINATION

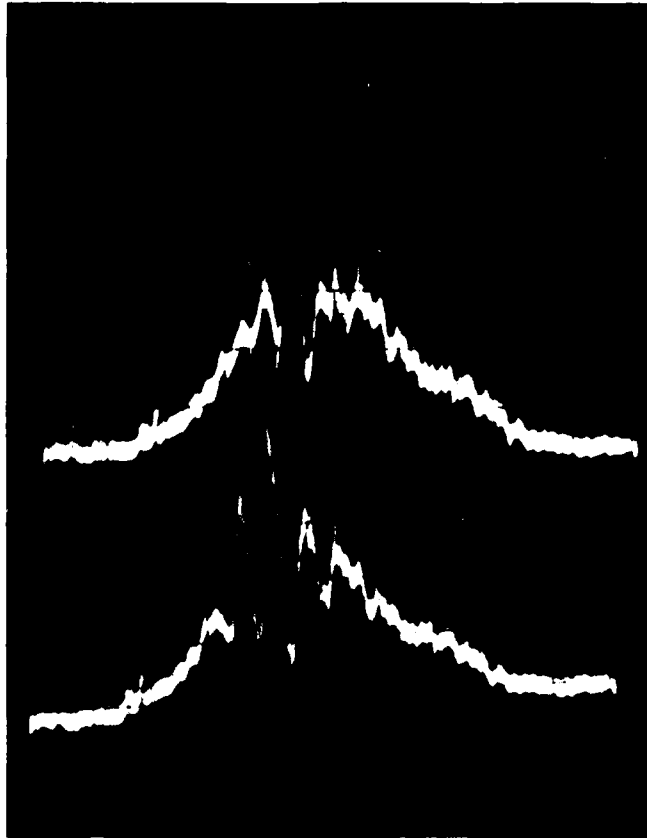

FIGURE 20 CORRELATION PRODUCED BY THE SYSTEM ILLUSTRATED IN FIG.19
AND THE FIRST PROTOTYPE OF THE ILLUMINATION SYSTEM

7.0 CONCLUSION

A first prototype of an holographic illumination system for the TIC constructed by BNR was built and its operation was demonstrated. The recording of better holograms will take place as soon as the power supply of the laser has been repaired. The utilization of a better hologram is expected to improve considerably the light budget of the TIC and special attention is going to be put on the production of low noise holograms.

8.0 REFERENCES

- [1] N.J. Berg, "Acousto-Optics Signal Processing: Theory and Implementation", Marcel Decker Inc., 1983, p.301.
- [2] D.A.B. Fogg, "A Compact Bulk Acousto-Optic Time Integrating Correlator", Defence Research Centre, Salisbury, South Australia, ERL-0323-TR.
- [3] "Development of a Time Integrated Acousto-Optics Correlator: Phase I, Final Report", prepared for DND by BNR, DSS contract 2SV85-00013, 1986.
- [4] K. Bumman, "A Study on Selected Wideband Guided-Wave Acousto-Optic and Electro-Optic Devices", Ph.D. thesis, Carnegie-Mellon University, 1979, p.24.
- [5] R.G. Hunsperger, "Integrated-Optics: Theory and Technology", Springer-Verlag, 1982.
- [6] R.J. Collier, C.B. Burkhart and L.H. Lin, Optical Holography, Academic Press, 1971.
- [7] D. Casasent and T. Luu, "Performance Measurement Technique for Simple Fourier Transform Lenses", Applied Optics, vol.17, no.18, p.2973-2980, 1978.
- [8] N. Brousseau, "Implementation of a Technique for Evaluating the Performance of Fourier Transform Lenses," DREO TN 80-23, 1980.
- [9] C. Durou, J.-P. Hot et R. Lefevre, "Effets simultanes du tassement et de la diminution d'indice de refraction de l'emulsion photographique en holographie", Nouv. Rev. Optique, t.7, no.2, 1976, p.87-94.
- [10] N. Brousseau and J.W.A. Salt, "Design and Implementation of a Time-Integrating Correlator Using Bulk Acousto-Optic Interaction", DREO TN-86-25, 1986.

SECURITY CLASSIFICATION OF FORM
(highest classification of Title, Abstract, Keywords)

DOCUMENT CONTROL DATA		
(Security classification of title, body of abstract and indexing annotation must be entered when the overall document is classified)		
1. ORIGINATOR (the name and address of the organization preparing the document. Organizations for whom the document was prepared, e.g. Establishment sponsoring a contractor's report, or tasking agency, are entered in section 8.) DEPARTMENT OF NATIONAL DEFENCE DEFENCE RESEARCH ESTABLISHMENT OTTAWA SHIRLEY BAY, OTTAWA, ONTARIO K1A 0Z4 CANADA		2. SECURITY CLASSIFICATION (overall security classification of the document including special warning terms if applicable) UNCLASSIFIED
3. TITLE (the complete document title as indicated on the title page. Its classification should be indicated by the appropriate abbreviation (S,C,R or U) in parentheses after the title.) DESIGN OF A HOLOGRAPHIC ILLUMINATION SYSTEM FOR AN INTEGRATED-OPTICS TIME-INTEGRATING CORRELATOR (U)		
4. AUTHORS (Last name, first name, middle initial. If military, show rank, e.g. Doe, Maj. John E.) BROUSSEAU, N. AND SALT, J.W.A.		
5. DATE OF PUBLICATION (month and year of publication of document) SEPTEMBER 1988	6a. NO. OF PAGES (total containing information. Include Annexes, Appendices, etc.) 26	6b. NO. OF REFS (total cited in document) 10
6. DESCRIPTIVE NOTES (the category of the document, e.g. technical report, technical note or memorandum. If appropriate, enter the type of report, e.g. interim, progress, summary, annual or final. Give the inclusive dates when a specific reporting period is covered.) DREO TECHNICAL NOTE		
8. SPONSORING ACTIVITY (the name of the department project office or laboratory sponsoring the research and development. Include the address.)		
9a. PROJECT OR GRANT NO. (if appropriate, the applicable research and development project or grant number under which the document was written. Please specify whether project or grant) 041LK11	9b. CONTRACT NO. (if appropriate, the applicable number under which the document was written)	
10a. ORIGINATOR'S DOCUMENT NUMBER (the official document number by which the document is identified by the originating activity. This number must be unique to this document.) Technical Note 88-24	10b. OTHER DOCUMENT NOS. (Any other numbers which may be assigned this document either by the originator or by the sponsor)	
11. DOCUMENT AVAILABILITY (any limitations on further dissemination of the document, other than those imposed by security classification) <input checked="" type="checkbox"/> Unlimited distribution <input type="checkbox"/> Distribution limited to defence departments and defence contractors; further distribution only as approved <input type="checkbox"/> Distribution limited to defence departments and Canadian defence contractors; further distribution only as approved <input type="checkbox"/> Distribution limited to government departments and agencies; further distribution only as approved <input type="checkbox"/> Distribution limited to defence departments; further distribution only as approved <input type="checkbox"/> Other (please specify):		
12. DOCUMENT ANNOUNCEMENT (any limitation to the bibliographic announcement of this document. This will normally correspond to the Document Availability (11). However, where further distribution (beyond the audience specified in 11) is possible, a wider announcement audience may be selected.)		

13. ABSTRACT (a brief and factual summary of the document. It may also appear elsewhere in the body of the document itself. It is highly desirable that the abstract of classified documents be unclassified. Each paragraph of the abstract shall begin with an indication of the security classification of the information in the paragraph (unless the document itself is unclassified) represented as (S), (C), (R), or (U). It is not necessary to include here abstracts in both official languages unless the text is bilingual).

(U) The design and implementation of a first prototype of a holographic illumination system for an integrated-optics Time-Integrating Correlator (TIC) are described. Correlation signals obtained with the TIC and the holographic illumination are shown.

4. KEYWORDS, DESCRIPTORS or IDENTIFIERS (technically meaningful terms or short phrases that characterize a document and could be helpful in cataloging the document. They should be selected so that no security classification is required. Identifiers, such as equipment model designation, trade name, military project code name, geographic location may also be included. If possible keywords should be selected from a published thesaurus, e.g. Thesaurus of Engineering and Scientific Terms (TEST) and that thesaurus-identified. If it is not possible to select indexing terms which are Unclassified, the classification of each should be indicated as with the title.)

> Time-Integrating Correlator;
Holographic Illumination System.