

42-4281 731

COMPARISON OF THE RESULTS OF TESTS ON A300 AIRCRAFT IN
THE RAE 5 METRE AN. (U) ROYAL AEROSPACE ESTABLISHMENT
FARNBOROUGH (ENGLAND) C. GUERARD ET AL. MAY 88

1/1

UNCLASSIFIED

RAE-1M-AERO-2130 DRIC-BR-108113

F/G 20/4

NL

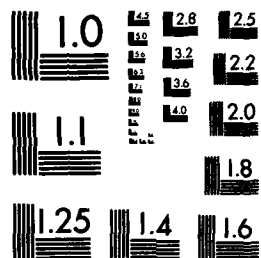

MICROCOPY RESOLUTION TEST CHART
NATIONAL BUREAU OF STANDARDS-1963-A

AD-A201 731

ROYAL AEROSPACE ESTABLISHMENT

Technical Memorandum Aero 2130

Received for printing 26 May 1988

COMPARISON OF THE RESULTS OF TESTS ON A300 AIRCRAFT IN THE
RAE 5 METRE AND THE ONERA F1 WIND TUNNELS

by

C. Quemard

P. B. Earnshaw

SUMMARY

Studies of the A300 Airbus aircraft have been carried out in the pressurised low-speed wind tunnels at RAE (5 metre) and ONERA F1. Initially comparison of the results obtained in the two facilities, with the same model mounted on an identical three-strut support, showed discrepancies which in the case of lift coefficient amounted to about 2.5%.

At the request of Airbus Industrie, and working within the framework of the Anglo-French Aeronautical Research Programme, AFARP, ONERA and RAE then began a systematic comparison of their measurement techniques together with the methods used in the reduction of the resulting data.

The production of uncorrected aerodynamic coefficients requires the measurement of loads by means, in this case, of underfloor balances and of the reference pressure. Checks were carried out on the balance calibrations confirming their accuracy after which an attempt was made in both establishments to assess and refine the accuracy of the reference pressure measurement. As a result of this exercise, corrections were applied to the measurements made in both wind tunnels which reduced but did not eliminate the differences between the two sets of results.

The data reduction relies on corrections to be applied for tunnel wall interference as well as that from the strut support system. Comparison of the calculation techniques used at the two tunnels showed some differences in the evaluation of certain terms resulting from wall constraint. Discussions have enabled agreement to be reached on defining a common basis for application of these corrections.

Support interference effects form the subject of a GARTEur Action Group study and both wind tunnels have representatives who serve on this Action Group. As a result of this common interest, a large number of tests carried out at RAE together with calculations made by both organisations have now led to very similar corrections.

Taking account of all these modifications including the measurements of reference pressure as well as corrections for wall and support interference, the results on lift and drag on the A300 which have been provided by the two tunnels now show good agreement confirming the accuracy of the measurement techniques and the broad framework of the corrections.

Copyright

©

Controller HMSO London
1988

LIST OF CONTENTS

	<u>Page</u>
1 INTRODUCTION	3
2 MODEL AND TEST	3
2.1 Wind tunnels	3
2.2 Support system	4
2.3 Model	5
3 DISCUSSION OF RESULTS	6
3.1 First comparisons	6
3.2 Review of measurements	7
3.3 Review of corrections	10
4 TABLE OF CORRECTIONS - NEW COMPARISONS	15
5 CONCLUSIONS	16
Illustrations	Figures 1-18
Report documentation cover	inside back cover



Accession For	
NTIS GRA&I	<input checked="" type="checkbox"/>
DTIC TAB	<input type="checkbox"/>
Unannounced	<input type="checkbox"/>
Justification	
By	
Distribution/	
Availability Codes	
Dist	Avail and/or Special
A-1	

1 INTRODUCTION

Check tests of the performance of aircraft from the Airbus series have been carried out in various major subsonic and transonic European wind tunnels. Among the low-speed tunnels, the RAE 5 metre and the ONERA F1 play an essential role since their pressurisation up to levels of three and four bars respectively allows a study of the effects of Reynolds number on the aerodynamic characteristics at constant Mach number and this permits a more reliable extrapolation to flight Reynolds numbers.

Both organisations have a common interest in demonstrating that their results are independent of the wind tunnel in which the tests were carried out. Evidently this interest is shared also by the aircraft manufacturers who might wish to plan test series in either tunnel.

It was within this context that a test was set up in 1981 by Aerospatiale in order to repeat in the F1 the same performance measurements of the A300B as had already been carried out at RAE. During their construction phases, the possible need to exchange models had already been foreseen. In particular, both tunnels have underfloor balances which are capable of mounting models by using what are essentially identical three-strut support systems. On its side, the 5 metre Tunnel had had constructed what might be regarded as a calibration model of the A300B aircraft early in the lifetime of the tunnel with a view to carry out an eventual programme of flight-tunnel comparisons. This model was made available to the F1 for their own test programme. This Memorandum aims therefore to describe the methods of test at both ONERA and RAE, the results obtained, and the critical study of the test and data reduction techniques which has enabled good agreement to be achieved.

2 MODEL AND TEST

2.1 Wind tunnels

The ONERA F1 wind tunnel at Toulouse (Fig 1) and the RAE 5 metre Wind Tunnel at Farnborough (Fig 2), are the two major European pressurised low-speed facilities. They were designed to allow studies of Reynolds number effects on the aerodynamic characteristics of high-life configurations used for landing and take-off.

The test section of the 5 metre is $5 \times 4.2 \text{ m}^2$ and that of the F1 is $4.5 \times 3.5 \text{ m}^2$. Maximum stagnation pressure is 4 bars in the F1 and 3 bars in the 5 metre. Consequently, the maximum Reynolds number calculated with a reference

length of $0.1\sqrt{\text{working section area}}$ is very similar in the two tunnels: it is achieved for Mach numbers between 0.2 and 0.3 corresponding to those for take-off and landing (Fig 3).

Civil aircraft models studied in the two tunnels typically have a span of around 3 metres, and a reference chord of around 0.4 m.

2.2 Support system

Several support systems are used in these low-speed tunnels in order to enable the desired model attitude to be achieved. Examples are shown in Fig 4.

Firstly, there is the classical sting support using a quadrant: several variants are available for the form of the sting including a cranked sting as shown in the photograph from the 5 metre and a blade sting shown in the F1. Then, there are strut supports, the simplest being the single strut shown here in the F1 where this is often used for studies of lateral characteristics, this support allowing simple application of both incidence and yaw.

Alternatively, as also shown in Fig 4, both tandem and three-strut mounting arrangements may be employed in which cases, in normal use, the struts are partially shielded from the airflow by guards attached to the test section floor in order to reduce the tare loads on the struts.

The three-strut mounting scheme which was in fact used for the comparative tests described here is shown in more detail in Fig 5 as used in the F1. Incidence variation is provided by varying the length of the rear strut and all three struts are carried on an underfloor balance which in the F1 is formed from a live plate supported from an earthed plate by six dynamometers (three vertical and three horizontal) each fitted with two strain gauge bridges.

The three-support system is in fact a copy of that used at RAE although shortened both in the struts themselves and their wind shields to allow for the reduced height of the F1 working section.

In the case of the 5 metre, the underfloor balance is a six-component, self-balancing weighbeam type of balance which is considered to offer inherently higher accuracy and ability to resolve smaller increments of load in the presence of large tare loads than an internal strain gauge balance.

2.3 Model

The model used in the two test programmes is Model 121.2, a 1/13 scale model of the Airbus A300B. This model has a steel wing equipped with various high lift systems representative of those on the full-scale aircraft:

- at the leading edges, Krugers and slats
- at the trailing edges, flaps and all-speed ailerons.

The spoilers and air brakes were not used during the RAE/ONERA comparative tests, nor have there been any tests with a horizontal tail.

The nacelles used were GE CF6.50 with short tailpipes, attached to the wing with M6 pylons.

Finally, the model could be equipped with a main undercarriage under the wings together with a forward tricycle undercarriage.

The various configurations of the slats and flaps studied in the two tunnels are as follows:

- landing 25/25 undercarriage both raised and lowered
- take-off 16/8 undercarriage raised
- take-off 16/0 undercarriage raised.

(the first number corresponds to slat angle and the second to the flap).

Since both facilities have the means to vary Reynolds number at constant Mach number, an ability which enables the results to be extrapolated to flight Reynolds numbers with better accuracy, lifting surfaces in most cases are tested without the use of transition fixing in order to avoid the problems of scaling the roughness element to suit the Reynolds number. This was so in this instance; there was therefore, no question that differences between measurements in the tunnels could occur as a result of differences in application of a transition trip on the wing.

For each of the configurations tested, the sensitivity to Mach number and Reynolds number was indeed studied. The comparative tests between the F1 and the 5 metre were as follows:

Table 1

F1	5 metre	Configuration	M	Re $\times 10^{-6}$
155	10015, 13001	25/25 *UCD	0.20	6.6
40	13002	25/25	0.20	6.6
126	10028	16/0	0.30	6.6
116	10029, 13020	16/8	0.26	8.2
86	13014	16/8	0.24	6.6
88		16/8	0.24	7.6

where *UCD indicates a configuration including undercarriage and where the first two columns give the records allocated in the two facilities to the particular polars being compared.

Fig 6 shows the overall dimensions of the model and its position in the F1 and 5 metre test sections. Fig 7 shows a photograph of a typical configuration in the 5 metre.

3 DISCUSSION OF RESULTS

3.1 First comparisons

Figs 8 and 9 show the results obtained in both tunnels for two typical landing and take-off cases, other conditions being essentially the same.

The lift coefficient C_L obtained at RAE is systematically higher than that at F1 and the lift curve slope itself is also greater at RAE, the relative discrepancy being in the range 2.5-3.0%.

The drag coefficient C_D at any particular C_L is lower at the RAE than at ONERA, the drag polars being more 'open' at the RAE.

Finally, there is a slight difference in the position of the aerodynamic centre as deduced from the pitching moment curves.

These discrepancies were too large to ignore and required an immediate inquiry to be made into their origins. The Anglo-French cooperative group, AFARP1, was given the task of seeking the source of errors in either the measurements themselves or in their interpretation.

Now an aerodynamic force coefficient is the ratio between the force measured on a balance and the product of the dynamic pressure $q_0 = 1/2 \rho V_0^2$ with the reference area S of the model:

$$C_F = \frac{F}{q_0 S}$$

The errors in the measurements themselves can therefore arise directly from the balance measurements and/or from the dynamic pressure. Less directly, interactions can arise through errors in the measurement of the model attitude relative to the approaching airflow whose direction of course defines the drag axis.

The coefficients are next corrected for the interference due to the presence of the walls on the one hand and of the supports on the other. These corrections are large and differences in the methods can contribute to discrepancies in the final results.

A systematic study was therefore mounted at both RAE and ONERA in order:

- to detect possible errors in the measurement of both forces and reference pressure,
- to establish the differences in the methods of correction and if possible to converge on a common technique.

3.2 Review of measurements

Force measurement

An obvious cause of error in the measurement of forces would of course be to use a balance for which the calibration had changed slightly. Check calibrations were consequently carried out on both the F1 and 5 metre balances and established that the accuracy was better in both cases than 0.1%. This leads, at the maximum dynamic pressure for which comparative tests were carried out (13 kPa), to the following maximum errors on the coefficients in the F1:

$$\Delta C_L = 0.01$$

$$\Delta C_D = 0.0010$$

$$\Delta C_m = 0.009$$

The repeatability of the measurements is better than this because it eliminates systematic errors which affect the accuracy. An example of the level of repeatability from the F1 is shown in Fig 10.

In the 5 metre tunnel, the maximum errors in coefficient terms are rather less, reflecting the better match of the model to the balance and tunnel. Thus:

$$\Delta C_L = 0.005$$

$$\Delta C_D = 0.0011$$

$$\Delta C_m = 0.0015 .$$

Checks on the calibrations of both of these balances have been carried out on both lift and drag axes using calibrated weights and pulleys. They showed no evidence of deviation outside of the expected limits on repeatability.

In conclusion, therefore, checks on the calibrations have shown no way in which the force measurements themselves could provide any systematic discrepancy.

Strut tares

Measurements made of both the lift and pitching moment must of course be corrected for the model weight. With this correction, the remaining forces are purely aerodynamic; these include the forces on the exposed parts of the support struts.

The strut tares are obtained in both tunnels by force measurements on the struts in isolation. Corrections to the coefficients, C_L , C_D and C_m , are then calculated and these subtracted from the total values.

Fig 11 shows the comparisons between the drag tares measured in the F1 and in the 5 metre. The agreement is excellent. Measurements in both wind tunnels suggest that it is advisable to correct C_L by 0.01; this correction was not taken into account at the F1. Consequently a correction $\Delta C_L = 0.01$ for F1 is included in the comparative tables of corrections arising from this comparison.

Reference pressure measurement

The reference pressure and speed are measured in the F1 by means of a pitot-static probe at the entrance to the test section.

The static pressure derived from this has been calibrated with respect to that existing on the tunnel centre line by means of an axial probe 5 metres in length. These measurements showed the existence of a slight streamwise pressure gradient; the static pressure from the reference pitot-static probe is then corrected for the discrepancy from the true static pressure at the quarter chord point.

This correction had been applied at the time of the A300B tests. However, it has been supposed at the time that the total pressure was uniform across the test section. In the course of this comparative study, checks were carried out which demonstrated that the total head distribution is somewhat 'dished' across the test section. While the source of this variation is unconfirmed, a similar non-uniformity in the 5 metre tunnel is known to result from the losses induced by the screens in the non-uniform flow approaching the contraction. Neglect of this head loss leads to an overestimate of the dynamic pressure and thus to an underestimate of the coefficients by around 0.5%. Thus:

$$\frac{\Delta C_L}{C_L} = 0.005$$

which has to be added to the results in the F1.

After checking the static and total pressures, there remained the need to check that the measured references were not subject to interferences from the model flow field; that is to say that the reference pitot-static was effectively at infinity upstream. This check has been carried out in the F1 by comparing the usual reference pressures with those measured at 2.4 metres further upstream on the contraction wall, these latter being themselves calibrated with respect to the pressure on the test section centre line using the long axial probe.

The results were almost identical implying that the entry plane to the test section is indeed effectively at infinity upstream.

In the 5 metre tunnel, a standard elliptic nosed static probe, such as had been used satisfactorily for many years in low-speed wind tunnels at RAE, had been used to carry out the tunnel calibration. However, in the course of the comparative study, it transpired that at the higher Reynolds numbers per metre for which the tunnel had to be calibrated, boundary-layer transition occurred over the sensing holes. The turbulent boundary layer gave rise to about 0.75% increase in pressure sensed and this led to an effective decrease in measured dynamic pressure. This effect is shown in Fig 12, where the function ϕ plotted is the ratio between the pressure drop in the contraction to that measured by the probe with suitable corrections applied to allow for compressibility. During earlier tests this step change had been translated into a smoothed gradual

change over the tunnel operating range. At the typical test point considered later in section 4, the error relative to the new accurate calibration is 0.8% giving:

$$\frac{\Delta C_L}{C_L} = -0.008$$

Mean flow upwash

In both tunnels, the flow angularity had been measured by inverting calibration models. In the F1, tunnel geometry had not been changed, it was possible therefore to confirm that the zero value of the mean upwash was accurate.

Unfortunately, in the 5 metre tunnel where the mean upwash had been measured as -0.09° , the non-uniformity of upwash had been considered unsatisfactory and a high quality honeycomb had been installed before the comparative test programme had begun, reducing the mean upwash to zero. Although there seems no reason to question the earlier value, it is now no longer possible to confirm it. It should be pointed out however, that in order to provide an accuracy on lift of 0.1% at $C_L = 2$, the upwash should be accurate to 0.02° while to provide an accuracy of five drag counts would demand an accuracy on upwash of 0.015° .

3.3 Review of corrections

Wall corrections

The results of the wind tunnel measurements have to be corrected for the interference generated by the test section walls and by the model support system.

Wall constraint corrections in subsonic flow comprise corrections to the approach velocity or blockage corrections and corrections to the upwash or incidence corrections. Fig 13 gives an example of the different corrections applied successively to a polar for the A300B in the F1.

Blockage corrections themselves comprise solid blockage, wake blockage and separation blockage. Expressions with varying degrees of sophistication lead to the following values for the solid blockage:

$$\frac{dV_0}{V_0} = 0.0045 \quad \text{at the 5 metre}$$

$$\frac{dV_0}{V_0} = 0.0056 \quad \text{at the F1 .}$$

These two values should roughly be inversely related to the relative cross-sections of the tunnels to the power 3/2. The residual error of around 0.1% is evidently not a major contribution to the discrepancies between the tests.

Incompressible calculations modelling the far field of the wake by means of a source lead to the equation:

$$\frac{dV_0}{V_0} = \frac{S}{4C} C_D$$

where S is the model reference area and C is the test section area. This equation was used in the two tunnels but, at the RAE, C_D was taken to represent the minimum profile drag whereas, at ONERA, the total drag was used. After some discussion, it was agreed that it would be more appropriate to choose the part of the drag corresponding to the difference between the total drag and the vortex drag, for conditions where there were no extensive areas of separation. Thus:

$$\frac{dV_0}{V_0} = \frac{S}{4C} \left(C_{Dc} - \frac{kC_L^2}{\pi A} \right)$$

where the subscript c indicates corrected results, A the aspect ratio and k is a calculated value for the induced drag factor.

The third term in the blockage correction takes account of the effective increase in model volume generated by the presence of regions of recirculating flow. Basically the same correction is used in the two tunnels and is based on that derived by Maskell. Given that this is by and large applied only in the immediate neighbourhood of the stall, there is even less likelihood of substantial differences arising from this source.

In addition to the blockage velocities, the presence of the walls also modifies the local upwash velocities, and consequently the effective incidence of the model.

Evidently the upwash velocity generated by the presence of the walls varies over the whole wing. It is convenient to interpret the effect of this interference field as an increment in incidence for the same lift coefficient. To achieve this, classical theory indicates that the upwash must be calculated at the 3/4 chord point of any streamwise section. The mean effect of the wing as a whole must then be suitably weighted for the value of the local chord at any spanwise position.

The early results from RAE were in fact corrected on the basis of the upwash calculated at the 1/4 chord line.

The values of the correction in the two cases are:

$$\Delta\alpha = 0.502 C_L \quad \text{at } 1/4 \text{ chord}$$

$$\Delta\alpha = 0.586 C_L \quad \text{at } 3/4 \text{ chord}$$

giving:

$$\Delta C_L = \left(\frac{dC_L}{d\alpha} \right) \Delta\alpha \approx 0.1(0.586 - 0.502)C_L$$

and

$$\frac{\Delta C_L}{C_L} = 0.0084$$

which must be subtracted from the RAE results.

Finally, the application of this correction to incidence results in a rotation of the axes of the measured force. Thus:

$$C_L = C_L' \cos \Delta\alpha - C_D' \sin \Delta\alpha$$

$$C_D = C_L' \sin \Delta\alpha + C_D' \cos \Delta\alpha$$

When applied at the F1, the term $C_D' \sin \Delta\alpha$ used to correct C_L was neglected. In fact this term is not negligible and should be subtracted from the F1 results. Thus, typically:

$$\Delta C_L = 0.009 \quad \text{at } C_L = 2$$

Strut corrections

In the absence of any information on the interference which the support system induces on the flow around the model, RAE began an experimental study of the support interference, while ONERA and Aérospatiale undertook a theoretical study of the flow about the support system.

Since the A300B model had been designed to permit support by both a three-strut rig and a tail-mounted sting support using an internal six-component strain-gauge balance, RAE assessed the effects of strut interference by mounting the model on an internal balance in the presence of the fairings from the strut support system, the strut tares themselves being measured in the absence of the model.

No attempt was made in the course of these tests to assess the near-field interference (largely of the wake of the strut tops with the flap flow) by including the strut heads on the model since, at the time when it was carrying out its experimental assessment of strut interference, RAE like ONERA was concurrently attempting to calculate the interference field of the support system; this was thought to be feasible only in the far field. In the presence only of the strut guards, however, interference simply of the far field was involved which enabled the results to be analysed using only the lift interference to establish the upwash and streamwash.

The effects of the strut interference as deduced from the experimental programme were interpreted as arising from modifications both to the mean streamwise velocity and to the mean incidence seen by the wing. Fig 16 shows the extent to which this simplified interpretation agrees with the experimental data as well as with the Aérospatiale calculations.

The main results from the Aérospatiale calculations using a panel method are presented in Figs 14 and 15.

The horizontal component of interference velocity is expressed in the form of a pressure coefficient C_p which, in compressible flow, is equivalent to the variation of dynamic pressure dq_0/q_0 . Fig 14 shows the variation of pressure along the length of the fuselage; in the first analysis of the A300B tests at the F1, a mean value of the dynamic pressure was chosen to correspond to that calculated for the mean 1/4 chord position, namely $dq_0/q_0 = 0.010$.

In a similar manner, the upwash velocity induced by the support system varies markedly both along the length of the model as shown in Fig 14 and along the span as shown in Fig 15 where the upwash is plotted as an increment in incidence. As for the blockage velocities, these results were analysed to provide a mean incidence calculated at 1/4 chord giving a value $\Delta\alpha = 0.22^\circ$.

These two corrections lead, at fixed incidence, to correction to C_L given by:

$$\Delta C_L = \frac{dC_L}{d\alpha} \Delta\alpha + C_L \frac{dq_0}{q_0}$$

Fig 16 shows the differences in corrections to C_L between the RAE experimental results and the theoretical results calculated specifically for the three-strut rig in the 5 metre test section. In addition to the curves, RAE's own calculated fit to the data is also given. At the time of these tests, this was equivalent to the single values for blockage and upwash velocities independent of lift. These values for ΔC_L used by RAE in its programme of data reduction are lower than those used at the F1 by about 0.01.

On the basis of this comparison then, it seems fair to conclude that the support corrections used in the two facilities were broadly similar at least so far as the lift is concerned and did not contribute substantially to the discrepancies found. However, this is not true of drag which is rather more sensitive to the accuracy of the upwash angle than is the lift. In this case, as has been noted above, at the F1, the upwash was calculated at the 1/4 chord line rather than the 3/4 chord line resulting in an error of 0.09° leading in turn to a significant correction to the drag of:

$$\Delta C_D = C_L \sin 0.09^\circ = 31 \times 10^{-4} \text{ at } C_L = 2$$

This modification in upwash correction from 0.22° to 0.13° then gives substantially better agreement on the drag as shown in Fig 18. For consistency, a corresponding additional small correction has to be made also to lift:

$$\Delta C_L = 0.009$$

Now a comparison of results from different facilities however, relies on the application of a common standard of support corrections, not necessarily an

accurate one. Consequently, the same form of correction using a single value for $\Delta\alpha$ and for dq_0/q_0 has been adopted in each tunnel.

Table 2

$\Delta\alpha$	dq_0/q_0	WT
0.156	0.014	5 metre
0.130	0.010	F1

These values give rise to an improved collapse of the experimental results over those used initially. They result from a rather better choice of mean values and follow in part from a detailed study of support interference carried out by an Action Group Working within the framework of GARTeur. Despite the agreement however, it remains possible that significant common errors in the measurements since the near-field interference from the strut top has not been treated in this comparison.

4 TABLE OF CORRECTIONS - NEW COMPARISONS

A detailed study of the various sources of difference between the results of the tests on the A300B in the F1 and 5 metres wind tunnels leads, for lift, to the following balance sheet, in which points from polar 88 in the F1 and from 10064 for the 5 metre are considered. In each case, a C_L near to two has been chosen.

Table 3

Source of correction	F1	5 metre
- corrections to balance loads	0	0
- corrections to support tares	-0.01	0
- corrections to dynamic pressures	+0.01	-0.016
- correction to wake blockage	+0.015	-0.002
- correction to incidence 1	-0.005	-0.017
2	+0.009	0
	+0.019	-0.035

In each column, a series of ΔC_L is listed which are either to be subtracted (-sign) or to be added (+sign) to the C_L calculated when the first comparisons were made (Fig 8). From this table, the discrepancy is reduced by 0.054, or 2.7% local C_L from its original value of around 0.06-0.07.

Some differences between the curves for C_L shown in Fig 17(a) and (b) remain but these are clearly less than 1% with the exception of the post-stall region.

The discrepancies in $[C_D - C_L^2/\pi A]$ shown as a function of incidence in Fig 18 now appear to be around 5×10^{-4} except for the region approaching the stall and are typical of the normal level of accuracy of the measurements.

5 CONCLUSIONS

Some considerable effort has been spent at both ONERA and RAE to ensure that the quality of the measurements carried out in the F1 and 5 metre tunnels should be very high. The existence of differences between the two sets of what should have been identical, fully corrected data led therefore to an immediate effort to identify, and then remedy, the sources of these differences.

As a result of the present comparative programme, a series of modifications to the procedures both in using reference pressures and in applying corrections for wall and support interferences have been introduced. Following the modifications, the corrected lift and drag measurements on the A300B which have been produced in the two tunnels now show very good agreement, confirming the accuracy of the measurement technique and the broad framework of the corrections. Evidently, there remains the possibility of errors which are common to both series of measurements, among which may be some arising from interference between the top of the struts with the wing flow, since in this case both tunnels have used essentially the same correction technique.

It is relatively rare that the opportunity to carry out a direct comparison using the same model on the same support is possible in two different tunnels. In this case, it was possible due to the close contact between the two design teams throughout the construction phases of the two tunnels. However, even with this advantage of direct comparability of measurement, the effort involved in undertaking the detailed re-examination must not be underestimated. The check calibrations of the balances, and more importantly of the tunnels, the design of new probes, and step-by-step comparisons of the calculations and application of wall and support interferences corrections have been time consuming but, as the results show, very rewarding.

With the benefit of hindsight, it might be felt that the changes which have now been shown to be necessary are obvious but in several of the cases involved here, they are applied to procedures or techniques which have been carried over from other wind tunnels where they have worked adequately, or at least have not been criticised in the past, and have consequently not demanded re-examination. In view of the present experience, it seems probable that such inadequacies may exist elsewhere but are likely to come to light only as a result of very exhaustive re-examination.

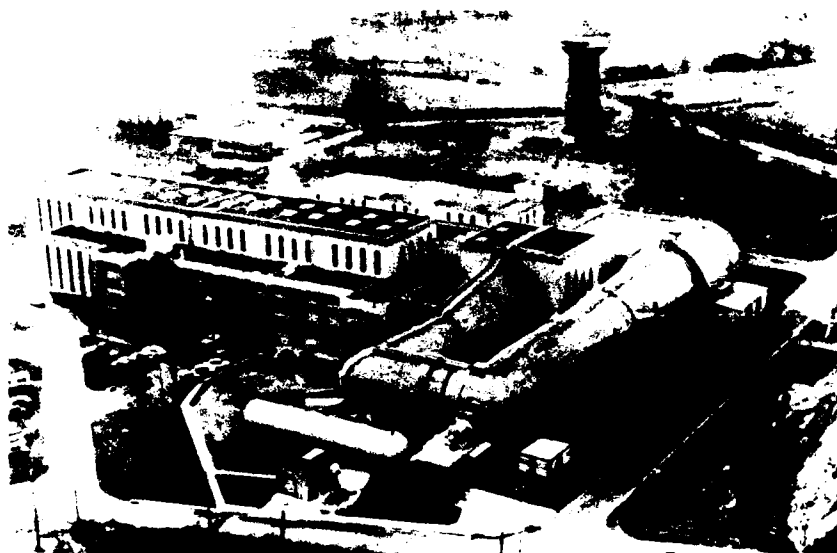

Fig. 1 - Aerial view of F1 wind tunnel.

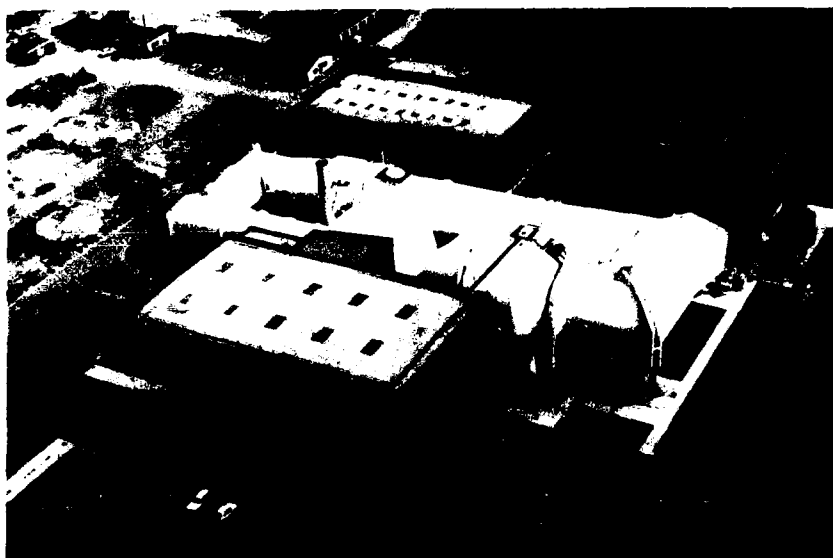

Fig. 2 - Aerial view of 5 metre wind tunnel.

TM AE 2130

Figs 3&4

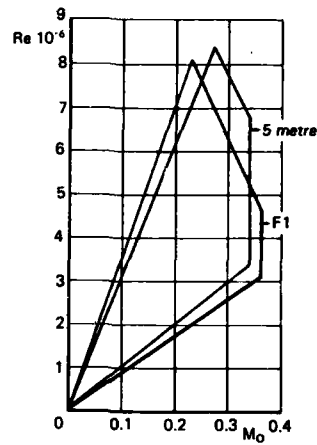

Fig. 3 - Performance envelope of 5 metres and F1
(Re based on $0.1 \sqrt{AREA}$ at $T = 15^{\circ}C$).

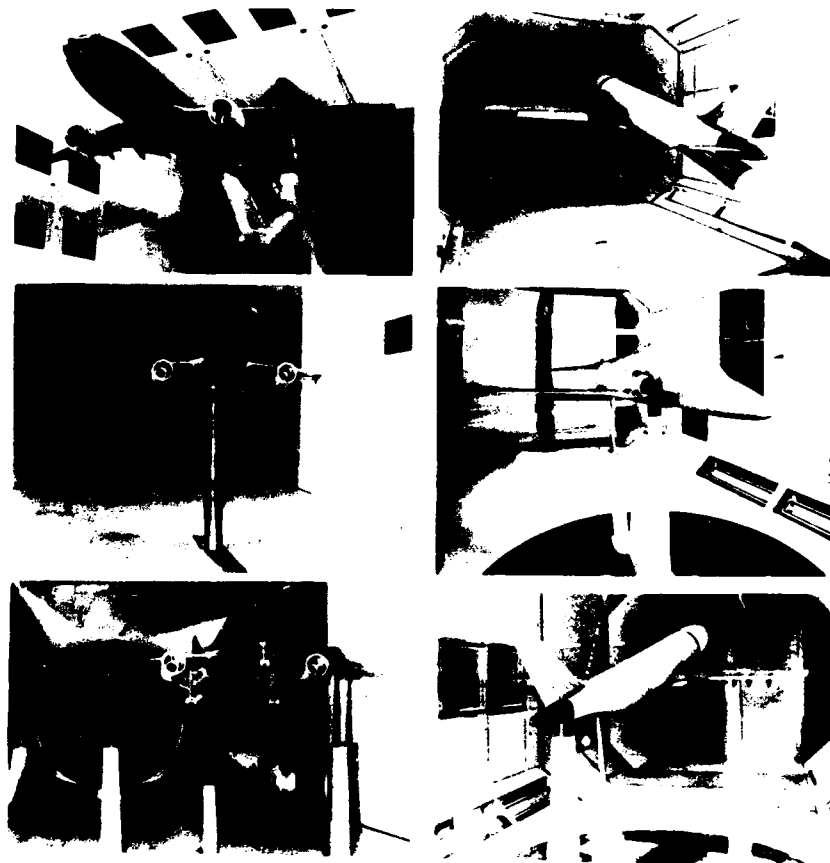

Fig. 4 - Some support option available in F1
and 5 metre win tunnels.

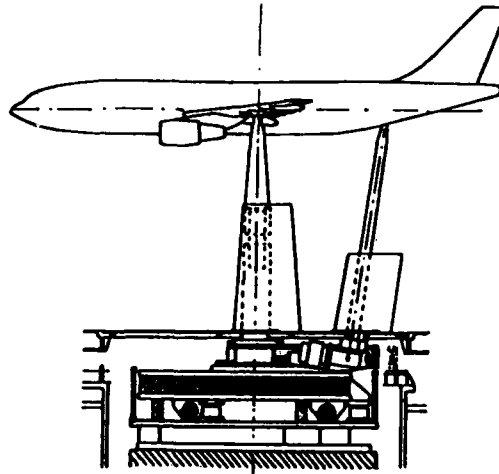

Fig. 5 - Model mounted on three-strut support system in F1.

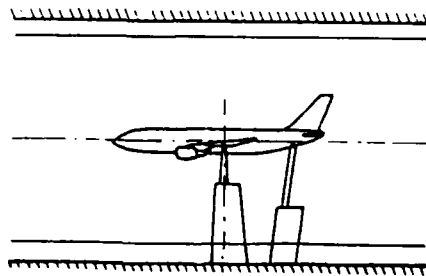
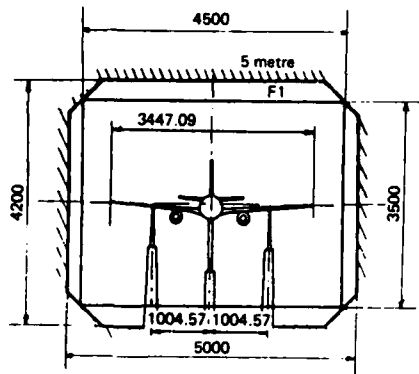

Fig. 6 - Position of model in F1 and 5 metre test section.

Figs 7&8

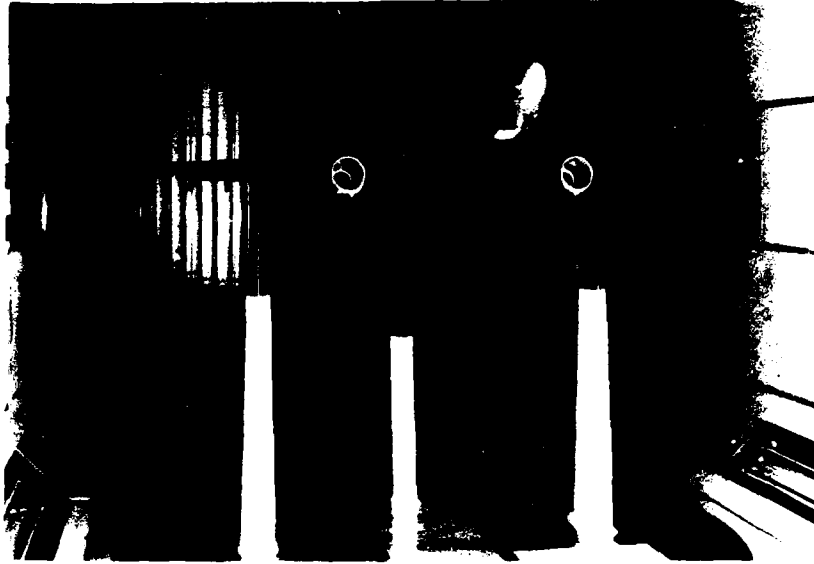

Fig. 7 - A300B model in 5 metre test section.

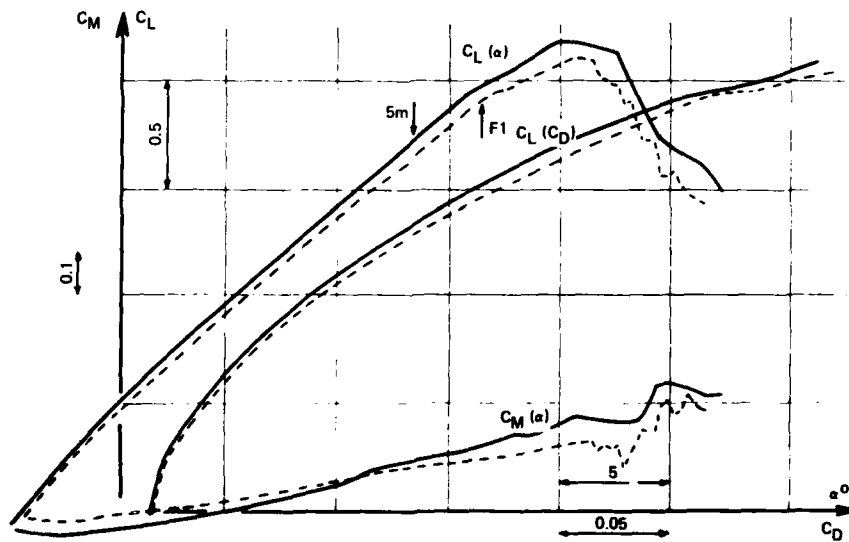

Fig. 8 - First comparative measurements on model in landing configuration.

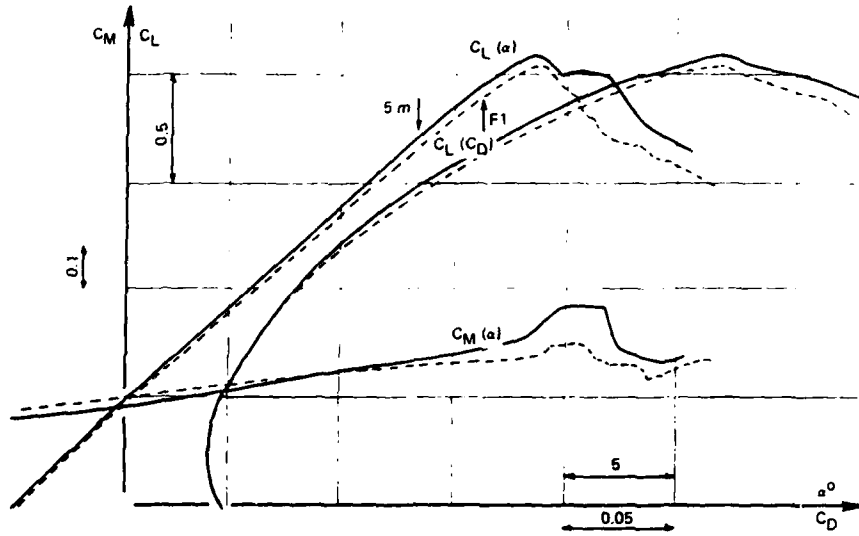

Fig. 9 - First comparative measurements on model in take-off configuration.

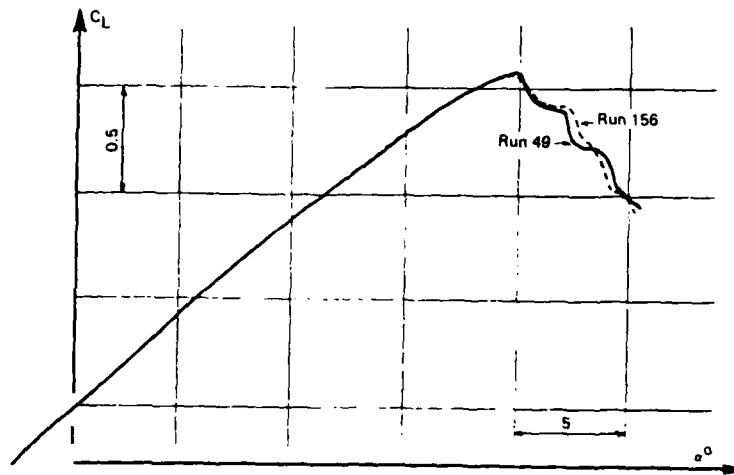

Fig. 10 - Repeatability of measurements in F1 (landing configuration).

Figs 11&12

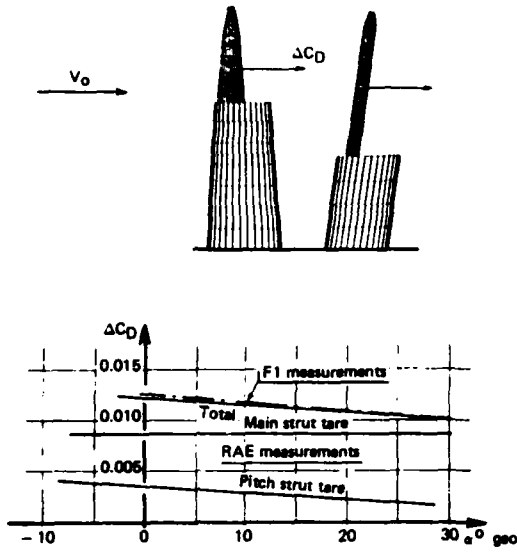

Fig. 11 - Drag tares for A300B strut system.

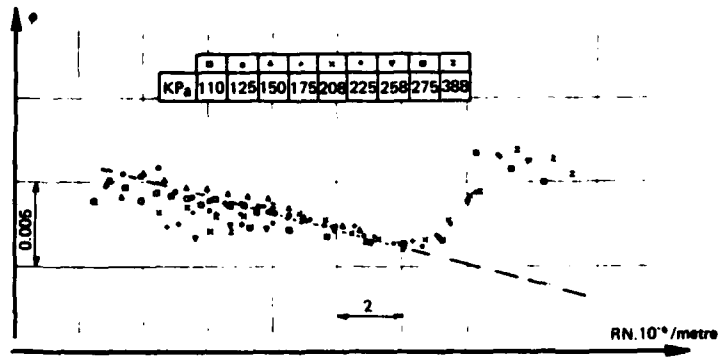

Fig. 12 - 5 metre wind tunnel calibration for August 1985.

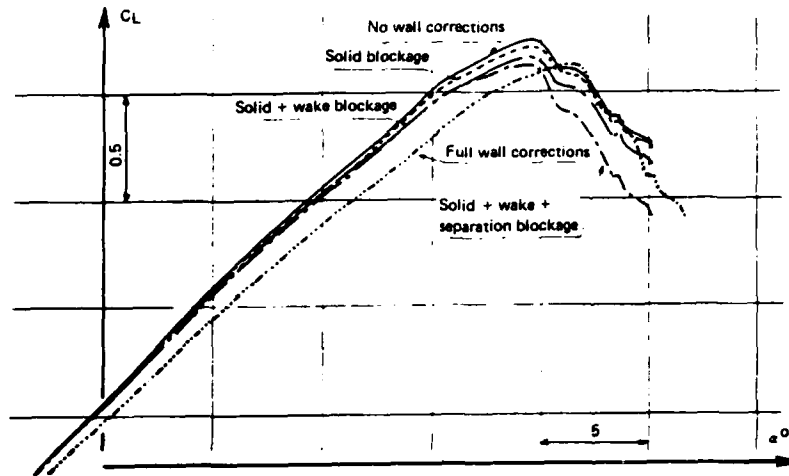

Fig. 13 - Successive applications of wall corrections.

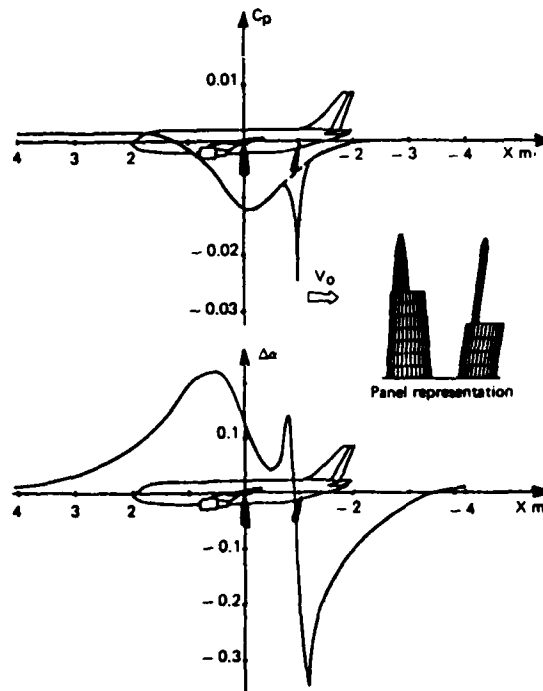

Fig. 14 - Variation of calculated pressure and upwash along model axis.

TM AN 2130.

Figs 15&16

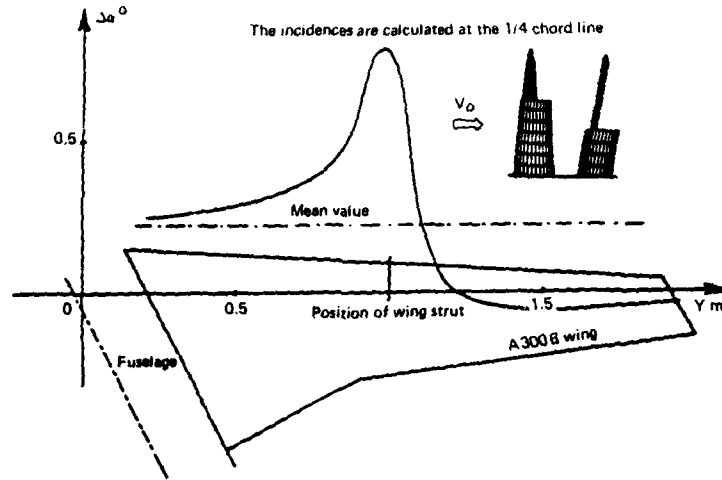

Fig. 15 - Local spanwise incidences on heavy duty struts.

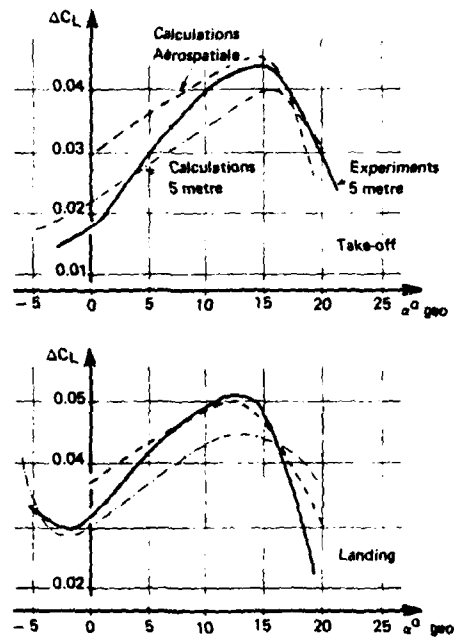

Fig. 16 - Lift correction due to strut interference.

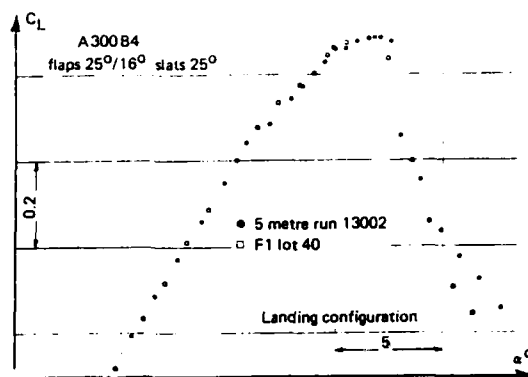

Fig. 17a - Comparison of finally corrected lift data.

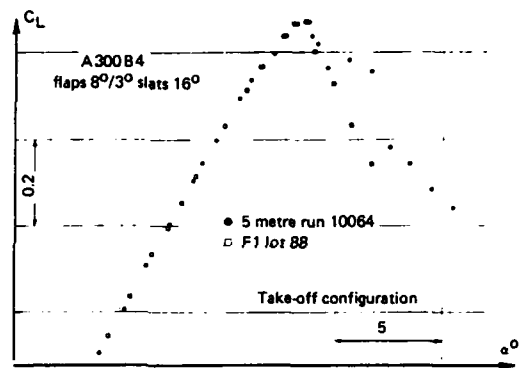

Fig. 17b - Comparison of finally corrected lift data.

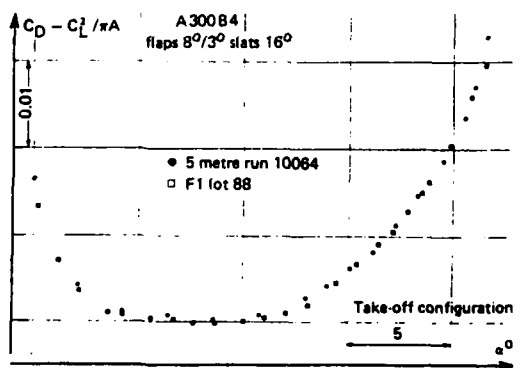
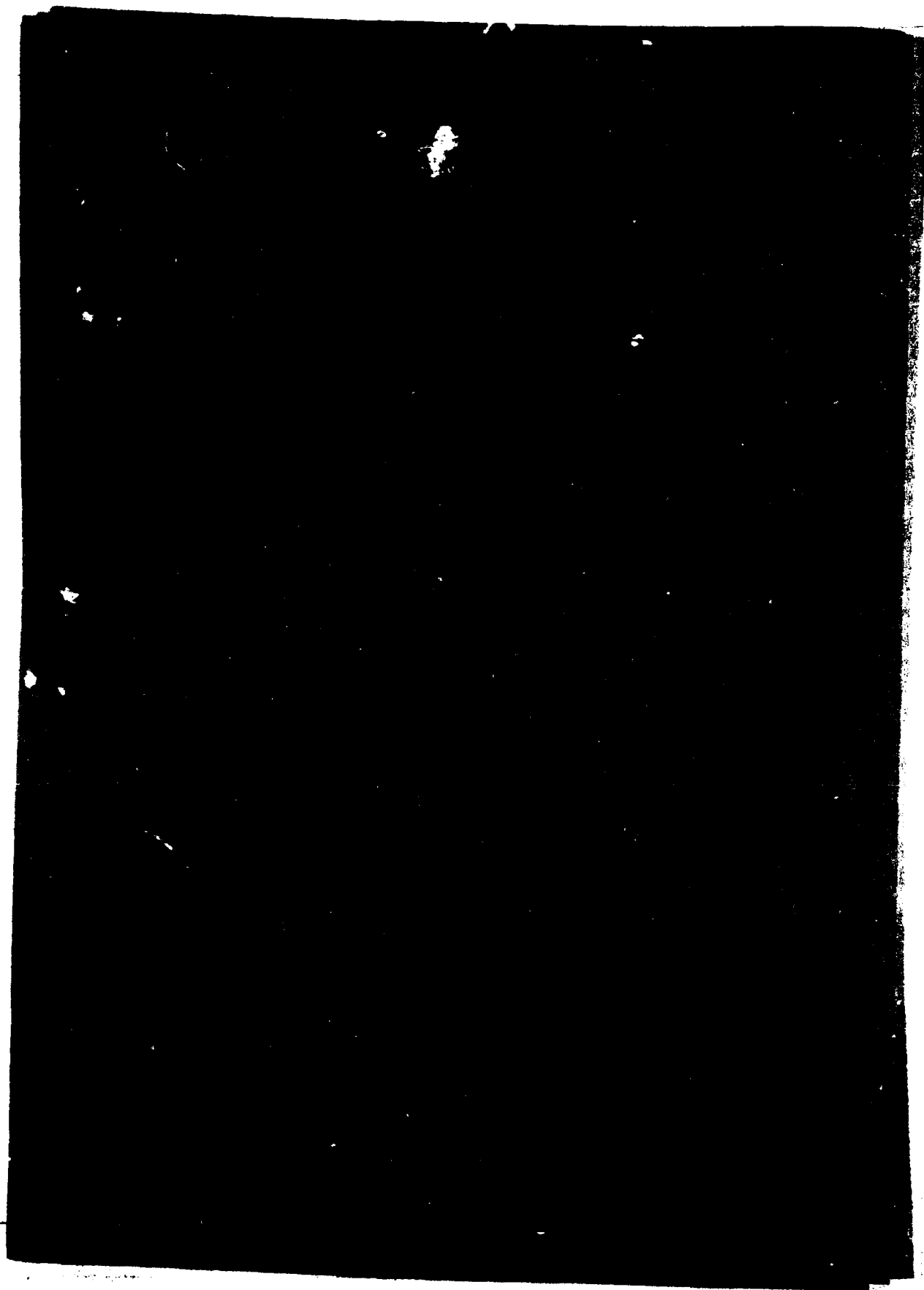

Fig. 18 - Comparison of finally corrected drag data.



END

DATE

FILMED

— 89