

2

AD-A202 451

DOCUMENTATION PAGE

OTIC FILE COPY

Form Approved OMB No. 0704-0188

SECRET
DEC 09 1988
D-3

23. SECURITY CLASSIFICATION AUTHORITY		16. RESTRICTIVE MARKINGS	
25. SECURITY CLASSIFICATION AUTHORITY		3. DISTRIBUTION/AVAILABILITY OF REPORT Approved for public release; distribution is unlimited.	
26. DECLASSIFICATION/DOWNGRADING SCHEDULE DEC 09 1988		5. MONITORING ORGANIZATION REPORT NUMBER(S) AFOSR-TR-88-1218	
4. PERFORMING ORGANIZATION REPORT NUMBER(S)		7a. NAME OF MONITORING ORGANIZATION AFOSR/NA	
6a. NAME OF PERFORMING ORGANIZATION Stanford University		6b. OFFICE SYMBOL (if applicable)	
6c. ADDRESS (City, State, and ZIP Code) Stanford, CA 94305		7b. ADDRESS (City, State, and ZIP Code) Building 410, Bolling AFB DC 20332-6448	
8a. NAME OF FUNDING / SPONSORING ORGANIZATION AFOSR/NA		8b. OFFICE SYMBOL (if applicable) NA	
9. PROCUREMENT INSTRUMENT IDENTIFICATION NUMBER AFOSR 87-0057		10. SOURCE OF FUNDING NUMBERS	
8c. ADDRESS (City, State, and ZIP Code) Building 410, Bolling AFB DC 20332-6448		PROGRAM ELEMENT NO. 61102F	PROJECT NO. 2308
		TASK NO. A3	WORK UNIT ACCESSION NO.
11. TITLE (Include Security Classification) (U) Advanced Diagnostics for Reacting Flows			
12. PERSONAL AUTHOR(S) R. K. Hanson			
13a. TYPE OF REPORT Final	13b. TIME COVERED FROM 10/1/87 TO 9/30/88	14. DATE OF REPORT (Year, Month, Day) 1988 October 1	15. PAGE COUNT 37
16. SUPPLEMENTARY NOTATION			
17. COSATI CODES		18. SUBJECT TERMS (Continue on reverse if necessary and identify by block number)	
FIELD	GROUP	SUB-GROUP	Laser, Imaging, Combustion, Plasma Fluorescence, Reacting, Flow, oxygen, nitrogen
19. ABSTRACT (Continue on reverse if necessary and identify by block number)			
<p>Progress is reported for the past year of an interdisciplinary program aimed at establishing advanced optical diagnostic techniques applicable to combustion and plasma flows. The primary effort is on digital flowfield imaging techniques, which offer significant potential for a wide range of spatially resolved 2-d and 3-d measurements. The imaging is accomplished by recording light scattered from a planar laser-illuminated region using a modern solid-state camera. The scattering process is generally laser-induced fluorescence, though Mie scattering is also used in connection with sizing particles. Activities reported herein include: (1) basic spectroscopy and fluorescence imaging of O₂[*] and NO; (2) molecular velocity imaging; (3) imaging diagnostics for supersonic combustion; (4) imaging diagnostics for hypersonic flows; (5) plasma diagnostics; (6) laser photolysis shock tube for fundamental studies of reaction kinetics and spectroscopy; and (7) development of flow imaging hardware and software.</p>			
20. DISTRIBUTION/AVAILABILITY OF ABSTRACT <input checked="" type="checkbox"/> UNCLASSIFIED/UNLIMITED <input checked="" type="checkbox"/> SAME AS RPT		21. ABSTRACT SECURITY CLASSIFICATION Unclassified	
22a. NAME OF RESPONSIBLE INDIVIDUAL Julian M Tishkoff		22b. TELEPHONE (Include Area Code) (202) 767-0465	22c. OFFICE SYMBOL AFOSR/NA

1

TABLE OF CONTENTS

	<u>Page</u>
1.0 INTRODUCTION	1
2.0 PROJECT SUMMARIES	2
2.1 Basic Spectroscopy and PLIF Imaging of O ₂ and NO	2
2.2 Molecular Velocity Imaging	5
2.3 PLIF Imaging in Supersonic Combustion Flows	11
2.4 PLIF Imaging in Hypersonic Flows	15
2.5 Plasma Diagnostics	20
2.6 Laser Photolysis Shock Tube	23
2.7 Flow Imaging Hardware/Software	27
3.0 PRESENTATIONS AND PUBLICATIONS	32
3.1 Presentations (10/87 — 10/88)	32
3.2 Publications (10/87 — 10/88)	34
4.0 PERSONNEL	36
5.0 REFERENCES	37

2.0 PROJECT SUMMARIES

Included in this section are summaries of progress in each of seven project areas. Additional descriptions of this work may be found in the publications listed in Section 3.2. Reprints of these papers are available on request. Personnel involved in these projects are listed in Section 4.0.

2.1 Basic Spectroscopy and PLIF Imaging of O₂ and NO

Summary

This is a continuing effort, now in its third year, aimed at establishing techniques for PLIF imaging of O₂ and NO useful over a broad range of flow conditions. The work has three elements:

- PLIF computer code development to guide the selection of measurement strategies and to aid in the quantitative interpretation of PLIF data
- Static cell experiments, using absorption and fluorescence spectroscopy, to determine critical spectroscopic parameters which influence fluorescence signals
- PLIF technique development, including laser modifications and research on strategies for monitoring temperature, mole fraction or concentration, and pressure. (Velocity is addressed separately in Section 2.2.)

The work is motivated by the critical role of O₂ and NO in various aspects of propulsion research and the potential impact of a successful imaging diagnostic for these species. It is appropriate to deal with these species together since their excitation wavelengths are similar.

Discussion

Although we have previously shown that PLIF images of reasonable signal-to-noise ratio (SNR) can be acquired for O₂ and NO using either broadband or narrowband excimer laser excitation (e.g., see Refs. 1-3, listed in Section 5.0), research is still needed to identify optimum laser-excitation and fluorescence-detection strategies for PLIF imaging and to establish means of extracting quantitative information from the images. A critical element of this ongoing work is a computer code which allows quantitative calculation of the fluorescence spectrum emitted as a function of the relevant flowfield properties (temperature, pressure, velocity and species composition) and the specific laser excitation parameters. Over the past few years we have worked to assemble such codes for both O₂ and NO, and

these are now nearly complete. These are large, complex codes which include considerable spectroscopic information, since both O_2 and NO have many possible rovibronic transitions in the UV. Although a substantial effort was required to develop these codes, they are essential to our research in that they allow economical numerical simulation of candidate excitation and detection schemes and a reduction in the amount of costly (in time and money) laboratory work needed to establish PLIF approaches.

During the past year we have initiated laboratory experiments to validate the spectroscopic codes and to determine, where needed, those spectroscopic parameters which are not available in the literature. For example, there is very little information currently available on rotational energy transfer rates, electronic quench rates, and collisional line-broadening coefficients for these species, especially for high temperature conditions. The experiments typically entail high-resolution scans of laser wavelength with conventional absorption and/or fluorescence detection. The source is currently a tunable narrowband excimer (193 or 248 nm) together with a Raman shifter to generate additional windows of spectral tuning. As needed, we also intend to employ a frequency-doubled tunable dye laser. Our laboratory experiments currently utilize a static cell, operable over a range of pressure (up to 20 atm), temperature (up to 800 K) and composition. Analysis of the measured absorption linewidths, fractional absorption, and fluorescence yield and spectral distribution, enable determination of the dominant line-broadening, collisional transfer and electronic quenching rate parameters. We anticipate that the experiments will be extended in temperature by using a shock tube or atmospheric pressure plasma torch. Owing to the very high enthalpies of interest for hypersonic flight, temperatures of interest for PLIF imaging extend to about 7000K, or even higher under certain conditions of chemical nonequilibrium.

The laboratory spectroscopy work is still in an early phase. During the past year, a computer-controlled scanning mechanism has been designed and installed on the tunable excimer laser, and a variable pressure and temperature cell has been fabricated and installed in an oven. Initial high-resolution fluorescence excitation scans have been obtained in O_2 near room temperature and experimental procedures for signal averaging and processing are being implemented. The next step will be add a quantitative absorption channel into the experimental set-up, at which point we will be ready to begin acquiring final quality data. We anticipate that at least one more year will be required to complete this study of O_2 and NO spectroscopy parameters.

In the area of PLIF imaging, our recent effort has been aimed at analyzing, via the computer model, various laser excitation and emission detection schemes. A primary goal is to find efficient means of extracting temperature, O_2 and NO mole fraction (or

concentration), and possibly pressure, with a minimum number of excitation wavelengths. Our present choice for O_2 is to utilize a single pump laser source and to generate multiple wavelengths (during each laser shot) using Raman-shifting ideas, since multiple-laser experiments are much less attractive than single-laser experiments. For example, use of an argon fluoride (ArF) laser, together with a Raman cell filled to high pressure with H_2 , will allow simultaneous generation of tunable radiation at 193 and 179 nm. Alternatively, use of D_2 in the cell allows generation of 193 and 183 nm light. These wavelengths are well suited for detecting O_2 , and the use of two (simultaneous) wavelengths offers prospects for determining temperature through the ratio of PLIF signals (proportional to relative Boltzmann fractions in the absorbing states). An important element in our strategy is to take advantage of the strong predissociation present in the O_2 absorption spectrum as a means of obviating the usual uncertainties in absolute fluorescence measurements associated with unknown electronic quench rates. (It is worth noting that our suggestion to exploit predissociation has recently been followed up by other combustion diagnosticians who have recognized that the same concept can be applied to OH and perhaps other combustion species.) The controlled use of predissociation could be a significant turning point in the development of LIF and PLIF as quantitative combustion diagnostics.

In the case of NO, the optimum wavelengths are somewhat longer (225-245 nm) and may best be reached with an excimer-pumped, frequency-doubled dye laser. We are currently carrying out numerical simulations of excitation and detection wavelengths to establish the optimum strategy, and we are investigating promising strategies in the laboratory. This work has been greatly aided by installation of a new BBO doubling crystal in our dye laser during the past six months. The energy per pulse available at 230 nm has been increased from less than 1 mJ to about 4 mJ with this change in doubling crystal. We should note that we have also begun to investigate a completely new strategy for NO excitation based on pumping the (C,D \leftarrow X) transition rather than the standard A \leftarrow X approach. This new strategy would utilize the tunable excimer output at 193 nm, and a preliminary analysis suggests that substantial improvements in SNR may be obtained when the gas temperature is in excess of 1500 K.

Recent laboratory work on PLIF imaging of NO and O_2 has focussed on improving the optical train used in imaging experiments. In particular, Dr. Paul of our laboratory has recently designed an improved collection system based on a Cassegrain telescope which provides F/1.1 collection with a focal length of 95 mm. This sophisticated computer-based design increases the light gathering power of our collection system, at UV wavelengths, by about a factor of 20 over our previous system, and hence leads to a factor of more than 4 increase in SNR in the shot noise limit. We have had two of these systems fabricated for us,

and both systems are working well. Other combustion diagnosticians have been made aware of this advance and plan to acquire similar collection systems.

Other laboratory work has included installation of new excimer gas cabinets in three locations. These cabinets are now required to meet university safety regulations. In addition, we have installed a new fume hood system to provide improved removal of exhaust gases from the various laboratory combustion set-ups. Costs for these lab improvements were paid by Stanford.

During the next year we plan to investigate the new excitation/detection schemes outlined above in several small-scale experiments, including: a flat flame burner, an electrically heated torch, a small-scale supersonic combustor, a shock tube, a shock tunnel, and a high-enthalpy underexpanded supersonic jet facility.

Finally, we note our long-term goal of combining PLIF measurements of species concentration and temperature with 2-D velocity imaging. These ideas are discussed separately in the following section.

2.2 Molecular Velocity Imaging

Summary

The objective in this continuing effort is to establish a nonintrusive optical technique for imaging the velocity field in gaseous flows by sensing the motion of a molecular constituent of the gas mixture rather than that of seeded particles. Such a technique is needed especially in research involving high flow speeds and low densities. The approach we've selected as most promising is based on Doppler-shifted laser absorption monitored by fluorescence. This approach offers the potential of both 2-D and, eventually, 3-D imaging. Prior to the past year, our work on this topic (see Refs. 4-7) utilized iodine vapor as the molecular tracer, since this species has fortunate spectral coincidences with a primary wavelength of the cw argon ion laser, but during the past year our effort has been directed to extending this concept to gases which are either naturally present or more acceptable as additives in combustion tunnels or other flow facilities. In addition, a critical goal in our new work is to improve the temporal resolution of the measurement, through use of a pulsed laser source, so that an image would correspond to the "instantaneous" velocity field.

Discussion

During the early part of the past year, our primary effort was directed at line-narrowing a pulsed excimer (ArF) laser source so that the output spectral bandwidth would be narrow relative to the absorption lines of the absorbing species (O_2 or NO). This approach followed the strategy of our earlier work in which the three relevant parameters in the problem had the following necessary relationship: the laser linewidth is less than the Doppler shift which is in turn less than the absorption linewidth. Although this strategy is the most efficient way to use the available laser excitation energy, it suffers greatly from two problems: the difficulty in obtaining a sufficiently narrowed pulsed laser source (ultimately limited by the Fourier transform limit); and the limitation on the maximum measurable velocity (so that the Doppler shift will remain smaller than the absorption linewidth). In analyzing the inherent limits of this approach, it became clear that there was a simple alternative, namely to switch the characteristics of the laser and absorption linewidths so that: the absorption linewidth is less than the Doppler shift which is less than the laser linewidth. This idea is shown schematically in Fig. 1. This new approach has several important advantages over our previous scheme: (1) the laser linewidth can be adjusted to match the maximum velocity of interest, including hypersonic flow velocities; (2) the laser operation is much simpler in the broadband mode; and (3) the new method is free of the limitations imposed by widely varying absorption linewidths in many flowfields. We've performed initial experiments to investigate this new strategy, and an example result obtained in an underexpanded supersonic jet of 0.5% NO seeded in N_2 is shown in Fig. 2. Nitric oxide is an attractive material for velocity measurements since it is naturally present in many high-speed flows of interest and can be readily seeded when necessary.

The results shown in Fig. 2 provide a critical test of the concept, since the flowfield involves a density variation of more than 1000 (between the choked nozzle exit and the conditions just upstream of the Mach disc) and a concomitant range of Mach number from 1 to 5. In these experiments, we had only a single camera available, and the strategy involved collecting (in sequential laser pulses) two images for a given laser orientation. The first image is acquired for the forward-propagating laser beam only (laser sheet 1), while the second image is obtained by summing the signal for the forward and retroreflected beams (i.e., the sum of laser sheets 1 and 2). This simple strategy gives two numerical values for the signal at each flowfield position (i.e, camera pixel), and these can be readily manipulated to determine the flow velocity component in the laser direction. Details of this scheme are described in a recently submitted publication (paper 18 in Sec. 3.2), but the essential point is that the method is independent of the unknown absorption linewidth and electronic

New Broadband Pulsed-Laser Technique Provides 2-D Velocity Images

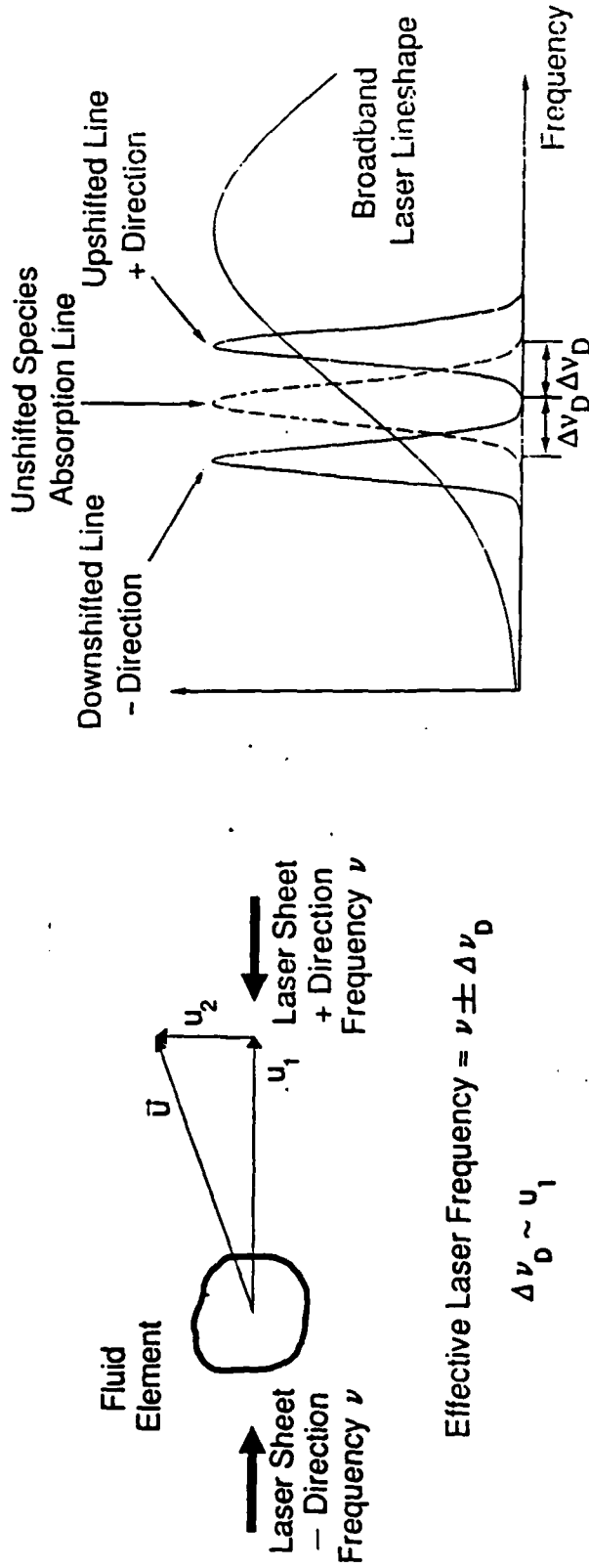

- Short laser pulsewidth (10 nsec) yields high temporal resolution
- Applicable to supersonic and hypersonic flows; no seeding required
- Range of velocity detection can be varied by changing laser linewidth
- Capability for simultaneous temperature and concentration imaging
- Multiple laser sheets yield multiple velocity components

Figure 1. Schematic figure illustrating a broadband laser approach for measuring gas velocity by means of Doppler-shifted absorption.

Pulsed PLIF Molecular Velocimetry Applied In Supersonic Flows

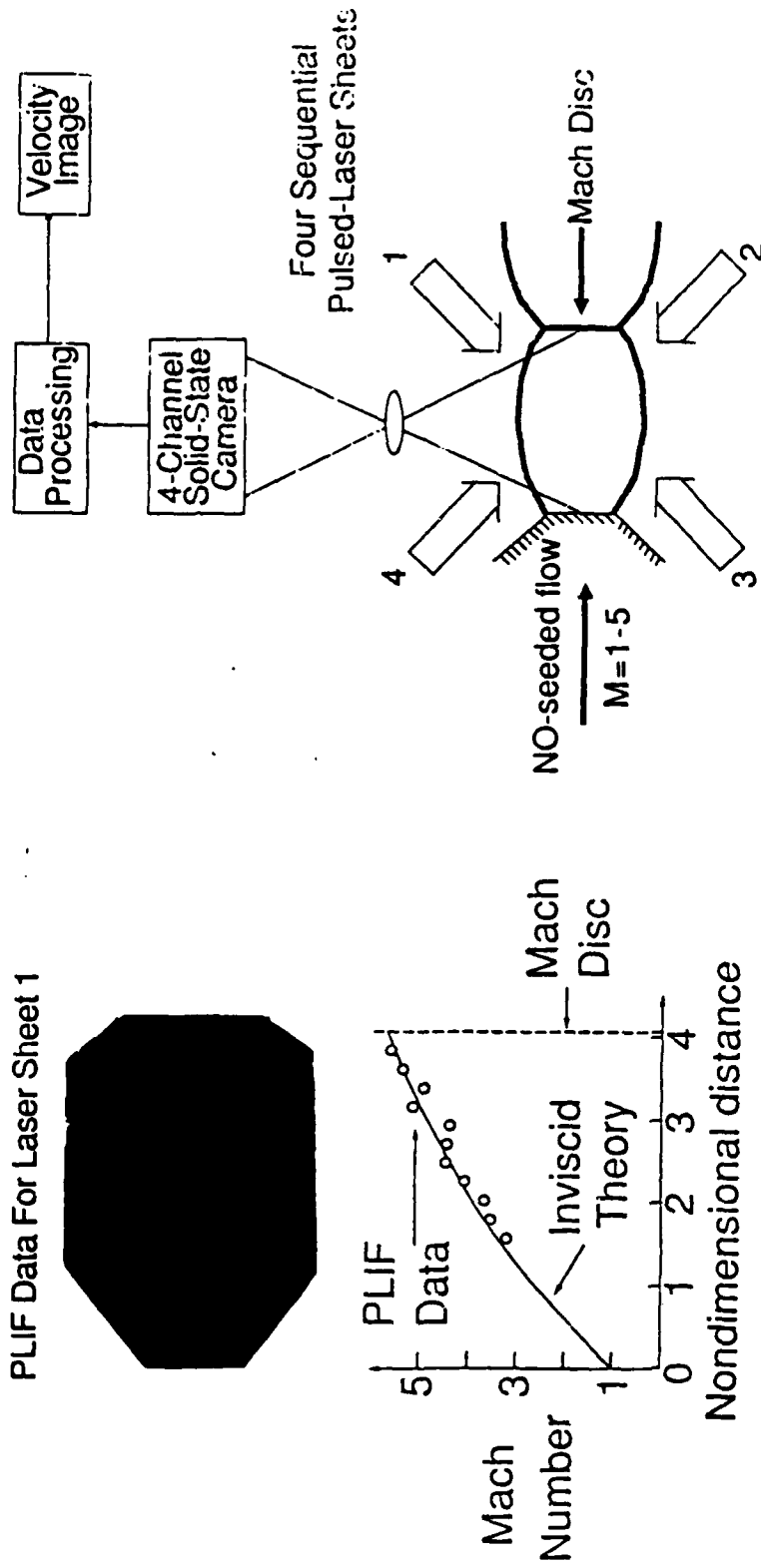

- Potential for single-shot (50 nsec) simultaneous measurements: two velocity components, temperature, density and concentration
- Technique also applicable to other species (e.g. O_2 , OH, Na, Cu)

Figure 2. Schematic diagram of 2-D velocity imaging concept and results for centerline Mach number in an NO seeded underexpanded supersonic jet.

quenching rate. By assuming that the flow is axisymmetric we are able to convert the single-component data to two-component velocity images; the comparison with theory shown in Fig. 2 is for the centerline Mach number, obtained by ratioing the measured velocity and the local speed of sound.

We believe that this new broadband laser approach to velocity imaging is extremely promising, and that this work may turn out to be one of our most important contributions to the field of laser diagnostics. Of course much work remains to be done to refine the concept, and to establish its limits. For example, a short-term goal is to find a way to obtain the 2-D velocity field using a single laser pulse and without any assumption of symmetry. The approach we presently favor is to pump two dye lasers with a single excimer laser pulse, thereby generating two dye laser pulses slightly separated in time and at two separate wavelengths. These beams will each cross the flow at different angles and be retroreflected. Four gated cameras will be used to record the PLIF signals from the rapidly sequenced laser sheets. The velocity component for each laser direction follows directly from the data for the forward and reverse beams. By exciting different transitions with the two wavelengths, however, the ratio of the signals obtained at a given flowfield point can be used to determine the relative population densities in the absorbing states and hence the Boltzmann temperature. This strategy appears to offer prospects of simultaneous determination of both temperature and velocity fields, and once the temperature is known it should be possible to use the PLIF signals for one of the laser wavelengths to determine the absolute concentration of the species. It should be noted that these are general concepts, and even though the application thus far has been limited to NO the method should also be well-suited to O₂ and other species with suitable fluorescence characteristics.

Our proposed scheme for simultaneous, multi-parameter PLIF imaging is shown in Fig. 3. We hope to explore this concept during the forthcoming year, although it will require acquisition of an additional dye laser and three additional intensified cameras which are not yet available.

PLIF System for Instantaneous Multiparameter Imaging

(2 components of velocity, temperature and mole fraction)

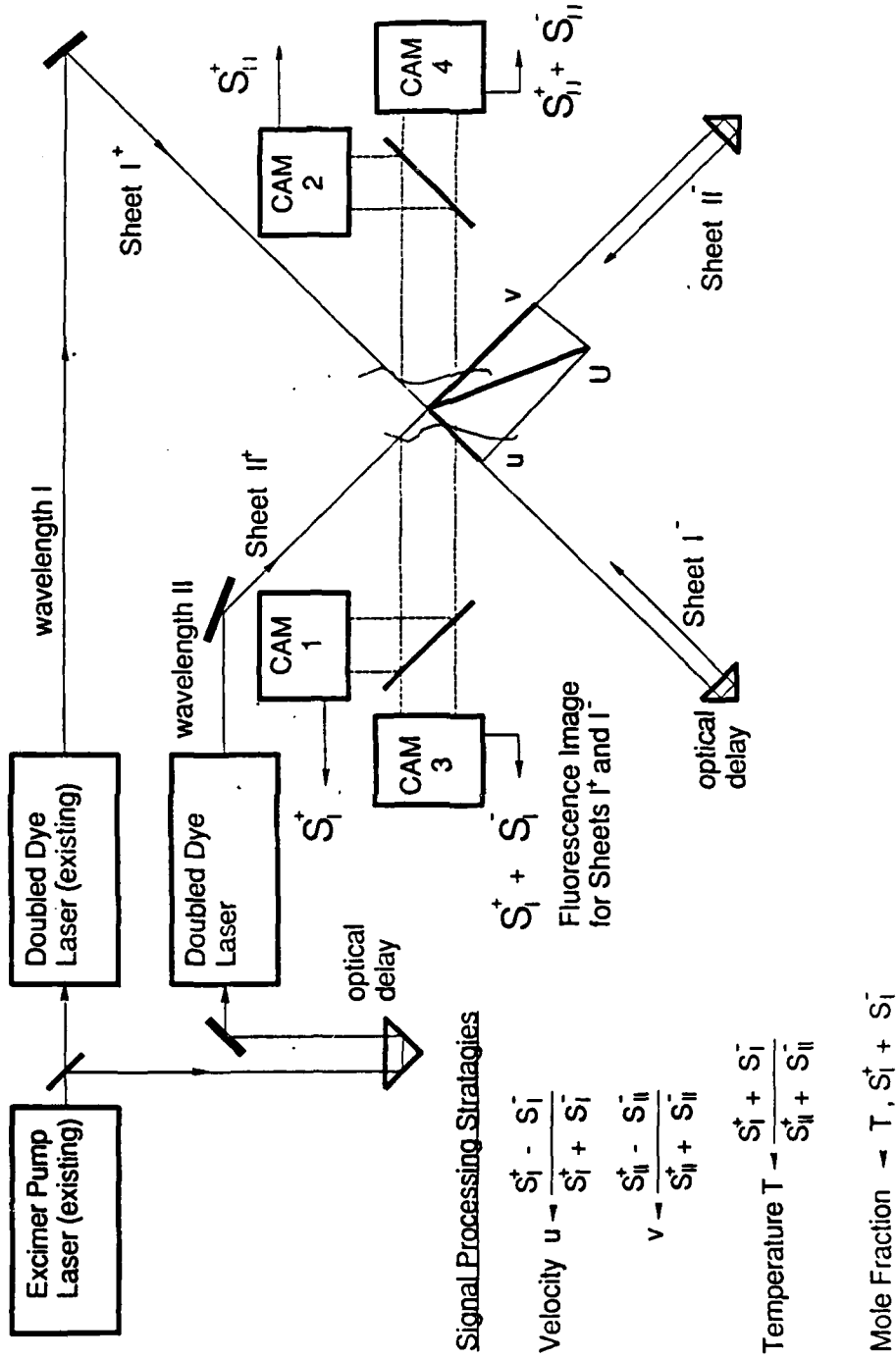

Figure 3. Schematic diagram of proposed PLIF strategy for instantaneous (single pump laser pulse) multiparameter imaging (velocity, temperature and species mole fraction).

2.3 PLIF Imaging in Supersonic Combustion Flows

Summary

During the past year we have increased our research activity on imaging diagnostics for supersonic combustion. Our primary goals have been to demonstrate the suitability of PLIF imaging in a reacting supersonic flow environment and to begin investigation of PLIF strategies with potential for characterizing such flows. In particular we note that the presence of compressibility in a reacting flow environment introduces important differences and challenges to diagnosticians relative to the incompressible flows which have been used in nearly all past research on laser diagnostics. With regard to PLIF, for example, a strategy must be developed which recognizes the convolved dependence of the fluorescence signal on several parameters: the total number density of the absorbing species, the Boltzmann fraction in the absorbing state (assuming that temperature is well defined!), the oscillator strength of the transition, and the fluorescence yield which may depend in a complex way on the local gas composition, density and temperature. The complexity of the problem strongly suggests that multi-measurement strategies are needed which yield multiple flowfield properties, probably through use of multiple excitation and detection wavelengths. Since the cost and complexity of multiple-laser experiments can quickly become prohibitive, a critical element of the research is to identify efficient diagnostics strategies. Accordingly, our work during the past year has been divided between analytical work to explore (numerically) candidate PLIF strategies and laboratory work to test the strategies of interest.

Discussion

Research during this past year has included: (1) design and fabrication of a small-scale supersonic combustor; (2) analytical work to investigate candidate strategies for PLIF imaging in compressible reacting flows; and (3) laboratory studies of PLIF imaging of OH in a bench-top supersonic combustor. These activities are described briefly below.

The bench-top combustor is shown schematically in Fig. 4. In essence, the design is similar to that used for flat flame burners and involves a stainless honeycomb burner surface with a small diameter (2.3 mm i.d.) stainless fuel tube protruding through the honeycomb material. The H₂ fuel is introduced through the tube from a high pressure source, providing choked flow at the tube exit. When the stagnation pressure is large enough, the tube flow is underexpanded relative to the surrounding ambient pressure and the resulting expansion accelerates the H₂ fuel to supersonic speeds. Concomitantly the fuel mixes with the surrounding air and burns as a turbulent nonpremixed supersonic jet. This facility is used in two separate modes: (1) for pressure ratios (i.e., the ratio of stagnation to ambient pressure)

up to about 3, the flame can be stabilized with only a slight co-flow of air through the surrounding honeycomb; and (2) for larger pressure ratios it is necessary to burn a fuel lean mixture on the honeycomb surface to stabilize a flame at the exit of the fuel tube. We have found that this simple water-cooled burner operates over a wide range of supersonic H_2 -air combustion conditions, and at the same time it provides convenient optical access since the combustion takes place in an open laboratory environment. The primary limitations of the facility are the relatively high noise level and the high mass flow rates which limit operating times between replacement of fuel cylinders.

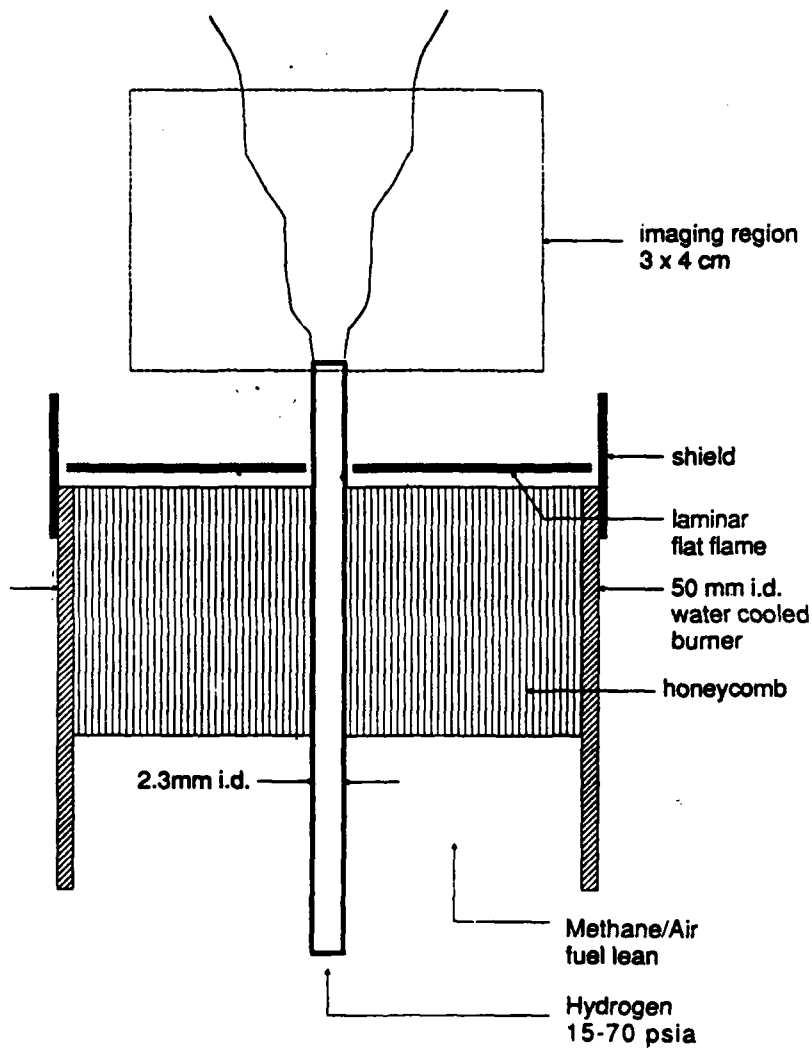

Figure 4. Schematic diagram of new laboratory-scale supersonic combustor to be used in diagnostics research.

Our analytical work has involved evaluation of various laser excitation and PLIF detection strategies, and in this work we have focussed thus far on OH as a species which will provide information on regions where combustion is occurring or has occurred. There are two promising excitation lasers, an excimer-pumped frequency-doubled dye laser and a tunable narrowband excimer (XeCl) laser. The dye laser is attractive since it can be operated over a wide range of wavelengths, thereby allowing study of schemes for determining both species concentration and temperature (through ratios of PLIF signals corresponding to excitation from different quantum states). On the other hand, the excimer laser provides a simple, relatively economical source with very high pulse energy. These high energies provide high values of SNR and allow study of possible saturated fluorescence schemes. At the present time we have completed analysis of several excitation-detection schemes and have begun to direct our efforts to laboratory studies.

An example of our first results for PLIF imaging of OH in the supersonic combustor is shown in Fig. 5 (see Ref. 8 for additional details). The images reflect the OH concentration in the central vertical plane of the combustor and were obtained in both single-shot and signal-averaged modes using a recently developed (in our laboratory) intensified CCD camera. The laser source was the tunable dye laser operating near 285 nm with an energy of a few mJ/pulse. These results clearly show the potential of PLIF imaging for detecting flame zone structure in a turbulent supersonic mixing layer, even at the relatively low concentrations expected for OH. Perhaps most important is the observation that the detailed structure evident in the single-shot images is washed out when the signals are averaged, thereby providing a clear example of the utility of instantaneous multi-point measurement schemes (i.e., imaging) for fundamental studies of these flows.

The status of the work is that the flow facility is currently being moved to the excimer laser laboratory in order to investigate the use of the tunable excimer laser source for PLIF imaging of OH. At the same time we will incorporate our new optical collection system. The result of a more energetic laser and more efficient fluorescence collection should be images with increased values of SNR. Subsequently we plan to investigate schemes for exciting multiple transitions of OH, for example by using two laser sources (with a slight time delay): the tunable excimer and the tunable dye laser. The images will be acquired with two separate CCD cameras, each time-gated to detect the PLIF signals for one of the sources. The output will be two PLIF images whose ratio can be used to infer temperature; the individual images can then be reduced to infer the OH concentration.

PULSED LIF IMAGING RESOLVES CHEMISTRY-FLOW STRUCTURE IN SUPERSONIC COMBUSTION

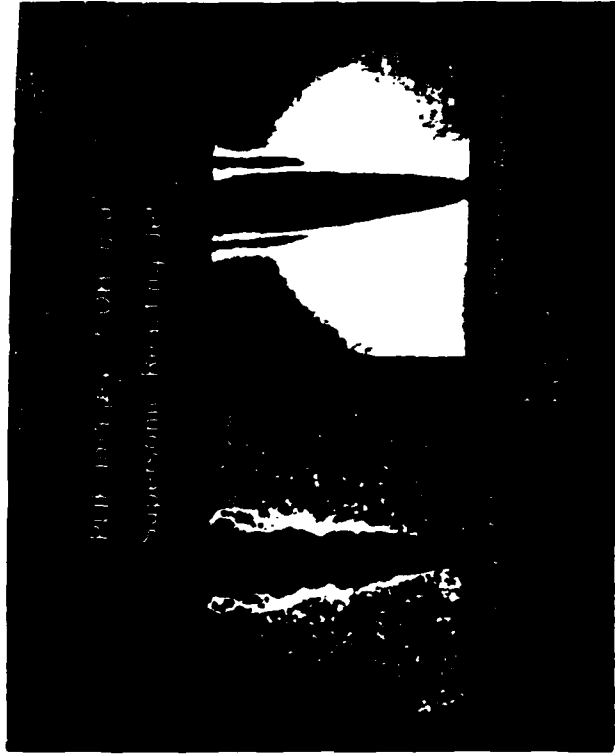
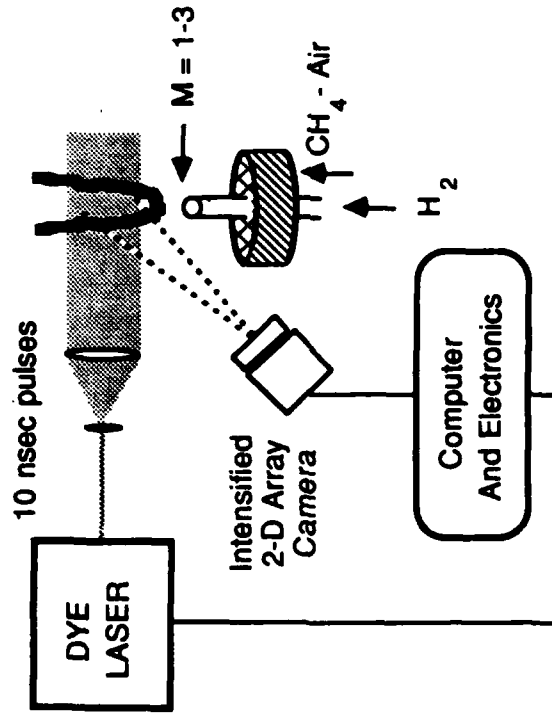

- Well-Suited for Fundamental Studies of Supersonic Mixing and Combustion
- Reveals Chemistry-Flow Structure Interactions Absent in Time-Averaged Images
- Data Rate of 7.5 Million Pixels Per Second; Framing Rate of 60 Hz

Figure 5. Schematic diagram and initial OH imaging results in supersonic combustor.

Hanson/Stanford

2.4 PLIF Imaging in Hypersonic Flows

Summary

Reacting hypersonic flows pose challenging new measurement problems for experimentalists. On the one hand, there is great potential impact for temporally and spatially resolved multi-point diagnostics, such as PLIF, since species-sensitive diagnostic techniques currently used in hypersonic flows are limited to single-point or line-of-sight measurements. On the other hand, the wide range of properties found in such flows, the high flow speeds which will introduce significant Doppler shifts, and the presence of significant compressibility effects, complicate the application of optical diagnostics previously developed in subsonic combustion flows. The Stanford program is aimed at investigating PLIF concepts which offer promise for such flows. During the past year, our effort has been divided between fabrication of new hypersonic flow facilities which will serve as test beds for the diagnostics research and initial feasibility studies of PLIF imaging in a simple underexpanded supersonic jet. These facilities and initial results are described below.

Discussion

Early in this reporting period we decided to pursue two approaches for generating hypersonic flows with high stagnation enthalpies. The first approach utilizes plasma heating at elevated pressures, followed by expansion of the gas to supersonic speeds. This is a steady flow facility which can provide several hours of continuous test time. The second approach utilizes shock wave heating and compression, followed by expansion to supersonic conditions. The latter facility is intended to provide a few hundred microseconds of test time, but with somewhat higher stagnation enthalpies. These two facilities will provide capabilities spanning a wide range of flow conditions well-suited for diagnostics research.

The plasma-heated flow facility takes advantage of a newly acquired (AFOSR URIP 1984/85, C.H. Kruger as PI) 75 kW RF power supply and plasma torch which was installed in the HTGL about 18 months ago. We've carried out a series of tests with this supply and proven that we can operate the standard RF-torch, which forms a part of the original system, at the elevated pressures needed to produce the stagnation conditions of interest. These tests confirmed that the torch will operate for an extended period at pressures of 3.7 atm (absolute) and stagnation conditions in excess of 6000 K for air (in chemical equilibrium). Calculations for these conditions indicate that gas velocities up to 5.3 km/sec can be achieved through expansion of the gases to a pressure of about 75 torr. At present we are fabricating the expansion nozzle and optical test section to accommodate PLIF imaging experiments. A necessary downstream heat exchanger is on order, as is the vacuum piping needed to link the

test section, heat exchanger and vacuum pump. We expect to have the system operational in approximately three months. A schematic of the system and list of operating parameters is given in Fig. 6.

RF DISCHARGE - SUPERSONIC FLOW FACILITY

Operating Parameters

- Stagnation Pressure = 1 to 3.7 atm. (40 psig)
- Input Power = 75 kW (DC) max
- Coupling Efficiency = 20 to 30 %

	Air	Argon
• h_0 (BTU/lbm)	1500 - 6000	1000 - 2000
• T_0 (K)	2900 - 6200	4700 - 9300
• U_{max} (m/sec)	2650 - 5300	2150 - 3050

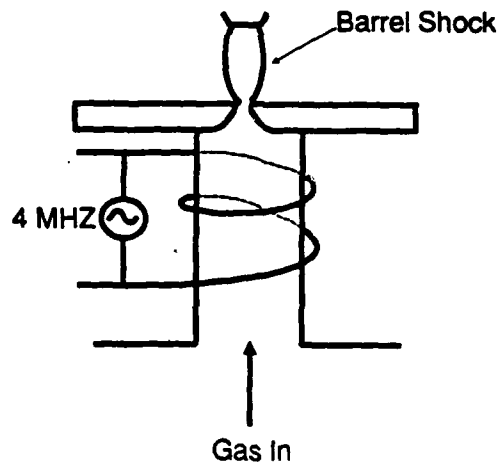

Figure 6. Schematic diagram of RF Discharge-Supersonic Flow Facility and list of operating parameters.

We should note that in parallel with the design and fabrication described above, we have carried out spectroscopic surveys of air plasmas exiting the torch to confirm that there

are no unexpected spectral regions of luminosity. The primary molecular radiators were found to be NO, O₂ and N₂⁺. Also, we have begun work to develop a computational model for the nonequilibrium hypersonic flows produced by the torch. Our present plan is to collaborate in this effort with researchers at NASA Ames Research Center who are engaged in assembling similar flow codes for other applications.

Our second planned hypersonic facility is a shock tunnel, shown schematically in Fig. 7. The status of this facility is that the shock tube portion was designed and assembled between January and June of this year, followed by installation of necessary peripheral instrumentation (e.g., shock wave detectors and pressure instrumentation) during early summer. We have recently performed initial PLIF imaging in this shock tube using excimer laser excitation of O₂. A schematic figure of the overall arrangement is shown in Fig. 8, while example results obtained for shock reflection from a stepped end wall are shown in Fig. 9. These are the first PLIF images obtained in shock-heated flows, and they were captured using our new 128×128 intensified photodiode array camera. It is important to realize that such images require the frame-on-demand capability of this camera and that such images could not be obtained with a standard video-based camera system. Our development of this camera capability is thus important for short duration, pulsed-flow experiments.

At present we are beginning design of the shock tunnel which will be added to the shock tube during the next few months. Subsequently we anticipate using the tunnel to explore several candidate PLIF schemes for measuring concentrations of interesting species (O₂, NO, O, and OH), temperature and velocity. As needed, we will use the hypersonic-flow computational code mentioned above for modelling the flows under study. Finally, we note that this new tunnel will also be used for studies of mixing and combustion in hypersonic flows once the PLIF imaging diagnostics are in hand.

In parallel with construction of the two new hypersonic flow facilities described above, we have utilized a simple underexpanded supersonic flow facility to verify performance of the new CCD camera system and to begin to investigate candidate PLIF excitation schemes. (This is the same flow facility mentioned in Section 2.2 in connection with velocity imaging.) Sample results, obtained for an iodine-seeded nitrogen jet, expanding to a Mach number of 2.5 at the Mach disc, are shown in Fig. 10. The region viewed is 20 × 8 mm, and the stagnation conditions are essentially STP. The important points to note are that the signal levels are quite respectable, even for single-shot imaging and with iodine levels of only 300 ppm, and that the new CCD camera has sufficient spatial resolution to resolve a range of scale sizes. Note in particular that the flow structure in the unsteady mixing regions of the flow are completely washed out by signal averaging, thereby clearly showing the important potential of single-shot 2-D imaging for studying such flows.

Proposed Stanford Hypersonic Shock Tunnel

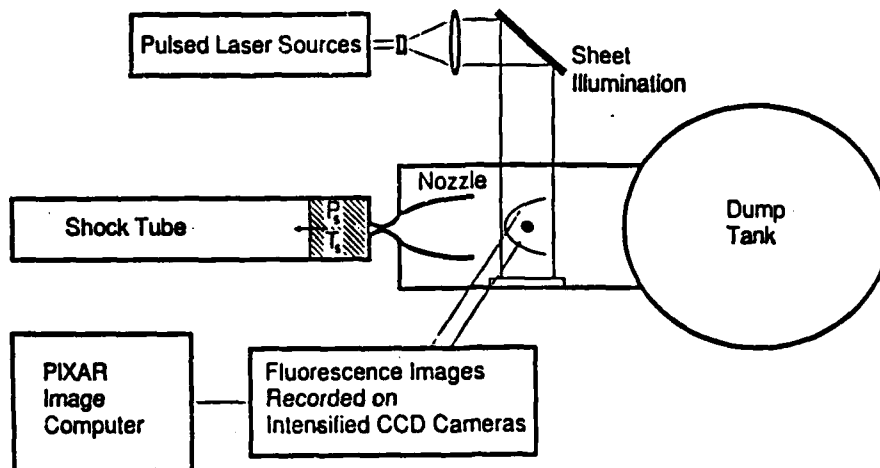

Research Objectives - Hypersonic Flows

Laser - Based Diagnostics Development

Propulsion Research (mixing, ignition, flame stabilization and combustion)

Aerodynamics Research (electronic, chemical and vibrational nonequilibrium)

Figure 7. Schematic diagram of Stanford shock tunnel now under construction.

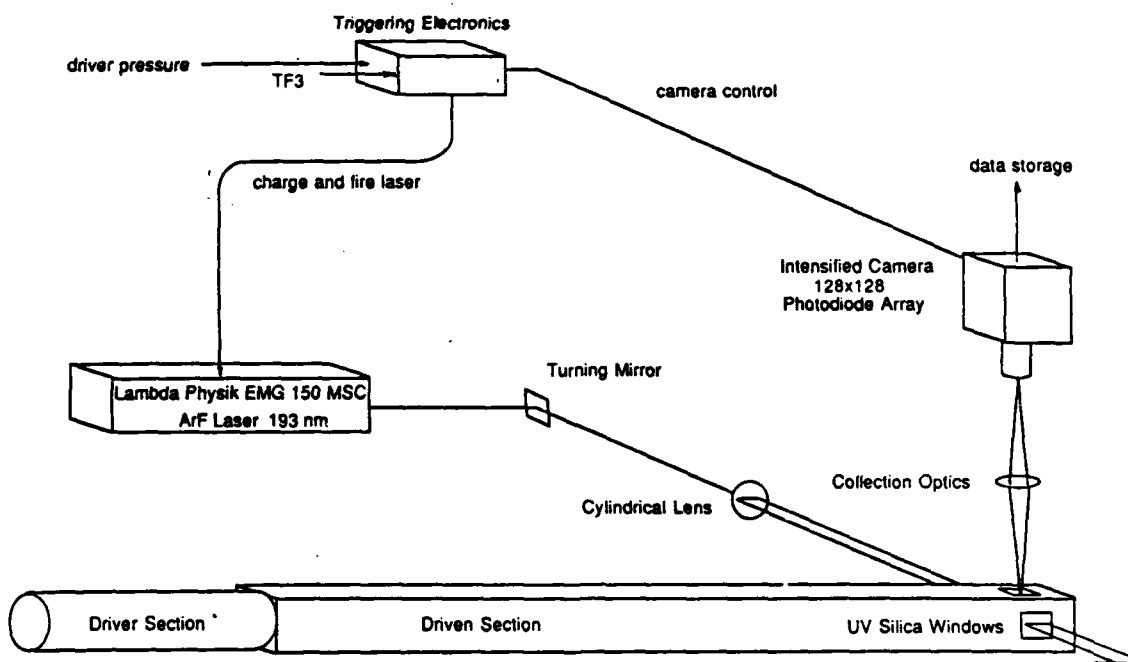

PLIF Imaging Schematic

Figure 8. Schematic diagram of experimental arrangement in current shock tube PLIF imaging experiments.

Shock Tube Imaging Geometry

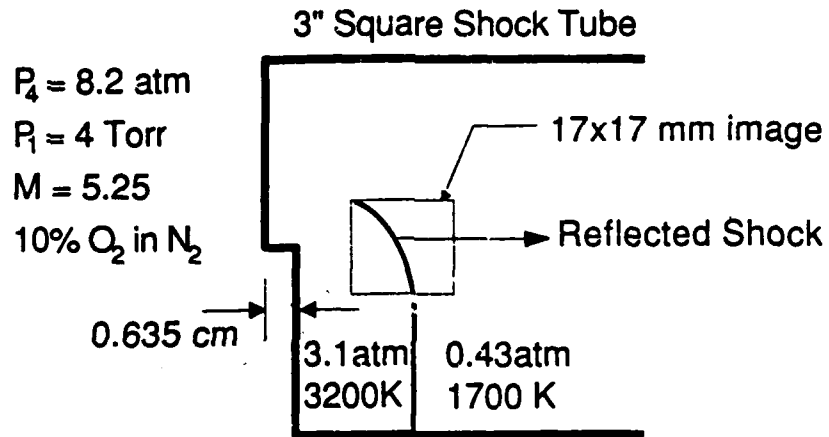

Figure 9. Imaging geometry for shock tube O_2 imaging and example result for shock reflection from a stepped wall.

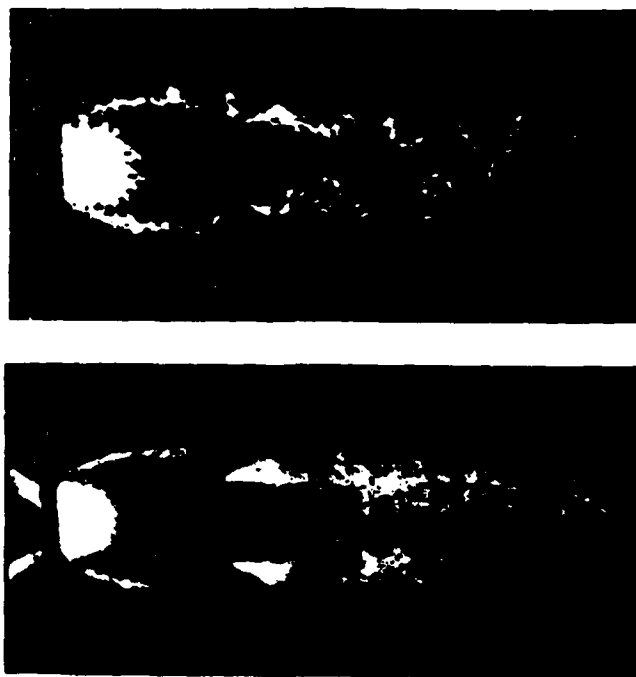

Figure 10. Single-shot (top) and 30-frame average PLIF images (20×8 mm) of I_2 in an iodine-seeded underexpanded supersonic jet of N_2 .

2.5 Plasma Diagnostics

Summary

During the past two years we have initiated an effort on laser-based plasma diagnostics. Primary motivation for the research arises from renewed interest in advanced space power and propulsion systems which may involve plasmas and the recognition that many of the modern diagnostic methods developed for combustion research may be applicable to plasmas. There are two diagnostics concepts we wish to explore: laser-wavelength modulation spectroscopy employing a narrow-linewidth cw tunable dye laser; and PLIF imaging employing a pulsed tunable dye laser. Two plasma facilities have been built as test beds for diagnostics research, a low-pressure plasma chamber and a high-pressure (atmospheric) plasma torch. Both of these facilities utilize RF-coupled excitation in order to provide a controlled plasma environment free of contamination of electrode material. Our primary accomplishments during the past year have been assembly of the

high-pressure plasma torch facility and initial testing of the wavelength modulation concept for spatially resolved, nonintrusive electron density measurements.

Discussion

During the past year our effort has been focussed on design and assembly of an atmospheric-pressure plasma torch for use in laser diagnostics research. The goal is to provide a convenient, steady plasma source, operable on a range of gases (and gas mixtures), with good optical access, and providing a wide range of plasma conditions (principally electron density and temperature). Ultimately we elected to build our own RF-powered plasma torch, since there were no commercially available units which met our performance criteria.

The system which we have assembled utilizes a 3 kW RF (27 MHz) power supply, coupled through a custom-made matching network, to a 1.8 cm diameter plasma torch. The torch body is comprised of three concentric quartz tubes to allow various strategies for gas mixing and swirl stabilization of the plasma. Although the primary plasma occurs within the torch body, the "tail flame" of the plasma extends a few cm above the exit plane of the torch, and it is this region which is used for diagnostics research. This design provides completely open optical access in a compact package which fits easily onto an optical table. Another virtue of the system is that there is no contamination of the flow with electrode material, since the electrodes are external to the plasma.

The RF plasma torch was completed about three months ago, and since then we have begun studies of diagnostic methods based on a cw tunable dye laser. The parameters of primary interest in the plasma are electron density, species concentrations (ions and neutral species), gas temperature, electron temperature and gas velocity. Briefly, our concept is to scan the laser source and record fully resolved absorption lines, using fluorescence detection to provide spatial resolution in the measurement. The area under such recordings can yield the species concentration, while the width of the line is related to either the gas temperature or the electron density, depending on whether the line is primarily Doppler broadened or Stark broadened. In cases where the gas has significant velocity, there will also be a shift in the apparent line position, and this shift can be measured to infer the gas velocity. These concepts are shown schematically in Fig. 11, together with an indication of the standard experimental arrangement for the measurements. To our knowledge, the approach outlined here represents a new strategy for plasma measurements, although the physical principles underlying the measurements are reasonably well known.

Spectrally-Resolved Fluorescence Spectroscopy Provides New Multi-Parameter Plasma Diagnostic

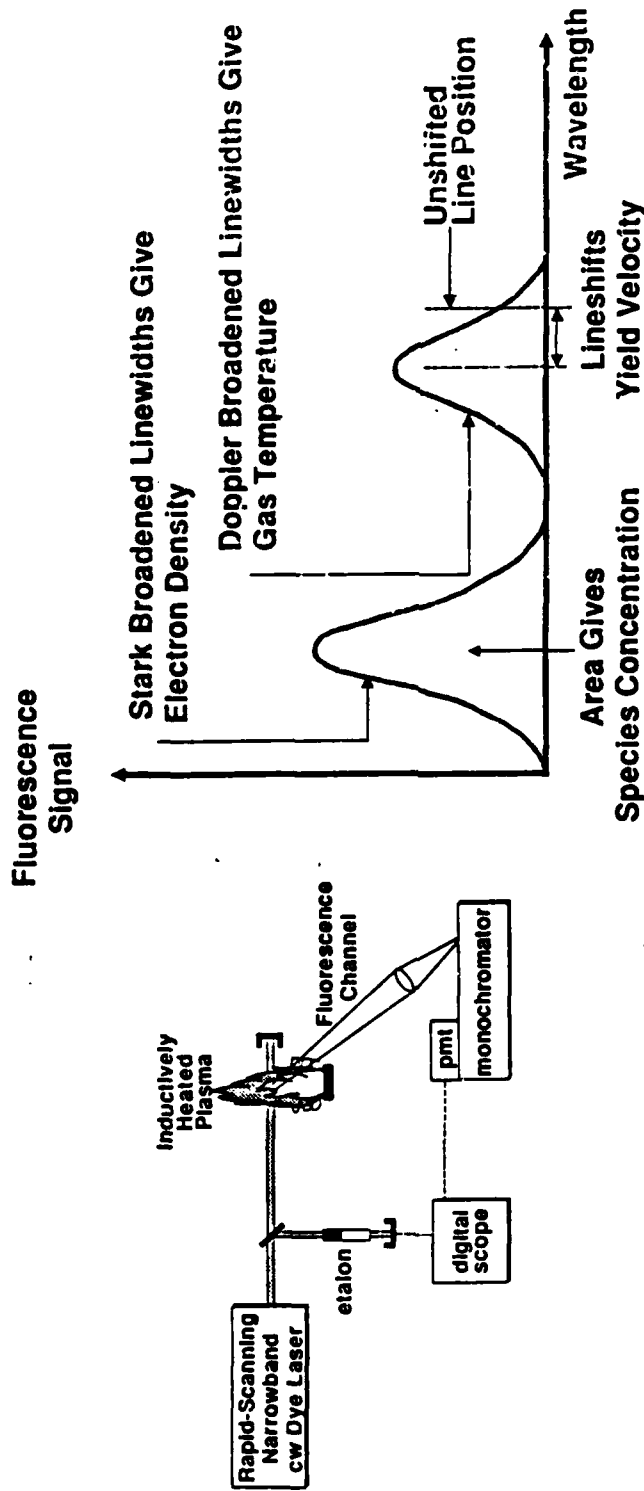

- Fluorescence Detection Provides High Spatial Resolution (<1mm)
- Fast Laser Scanning Allows First High Repetition Rate Measurements in Plasmas (>1kHz)
- Potential for Studying Fundamental Processes in Plasmas

Hanson/Stanford

Figure 11. Schematic diagram illustrating the experimental arrangement and physical concept for monitoring plasma parameters using spectrally resolved laser-wavelength modulation.

An example of initial results is shown in Fig. 12. Here we show the fully resolved LIF profile for the H-alpha line of atomic hydrogen at 656 nm, which enables determination of the electron density through the Stark-broadened linewidth. The plasma is nominally argon, seeded with 10% H₂. The hydrogen is fully dissociated in the hot regions of the plasma, and the argon is weakly ionized. The torch was operated at a power level of 2.5 kW, and the measurements were made on the torch centerline about 1 cm above the exit plane of the torch body. Atomic hydrogen is attractive as an indicator of electron density, since the relationship between the linewidth and the electron density is well known for Stark broadening. As indicated in Fig. 12, the measurement is quite sensitive to the electron density and good agreement between the theoretical and measured lineshape is found.

The measurements thus far have been signal averaged, owing both to the low signal levels obtained with the cw laser source and the finite time required to scan the laser wavelength across the necessary spectral range. One of our current objectives is to identify possible schemes for improving the temporal resolution of the measurement, for example through use of a pulsed laser source. Another objective is to identify atomic transitions in this plasma which are primarily Doppler broadened, and then to explore the use of spectrally resolved LIF for these transitions to determine the gas temperature.

Our current research is aimed both at characterizing the plasmas produced by the RF-torch and at investigating promising concepts for new diagnostic methods. For convenience in this effort, we have limited ourselves to single-point detection, which can be carried out with photomultipliers. Ultimately, however, we plan to adopt imaging detectors for use with the more promising diagnostics schemes. Our goal is to establish 2-D imaging techniques for plasma properties analogous to the successful methods currently being developed for combustion applications.

2.6 Laser Photolysis Shock Tube

Summary

The laser photolysis shock tube is a new concept for generating controlled levels of free radical species in a high temperature environment. In brief, a shock tube, operated in the reflected shock mode, is used to heat a gas sample to desired high temperature conditions, and a pulsed excimer laser is used to illuminate portions of the gas with high-intensity ultraviolet radiation. The UV photons act to photolyze a fraction of the initial molecules and thereby create a controlled level of free radicals. Such a clean, instantaneous source of radicals is of scientific interest because it will enable more direct studies of spectroscopic and reaction kinetic parameters of these species than have been possible in the past.

Stark Broadened LIF Profile of H α ($\lambda_0 = 656.28$ nm)

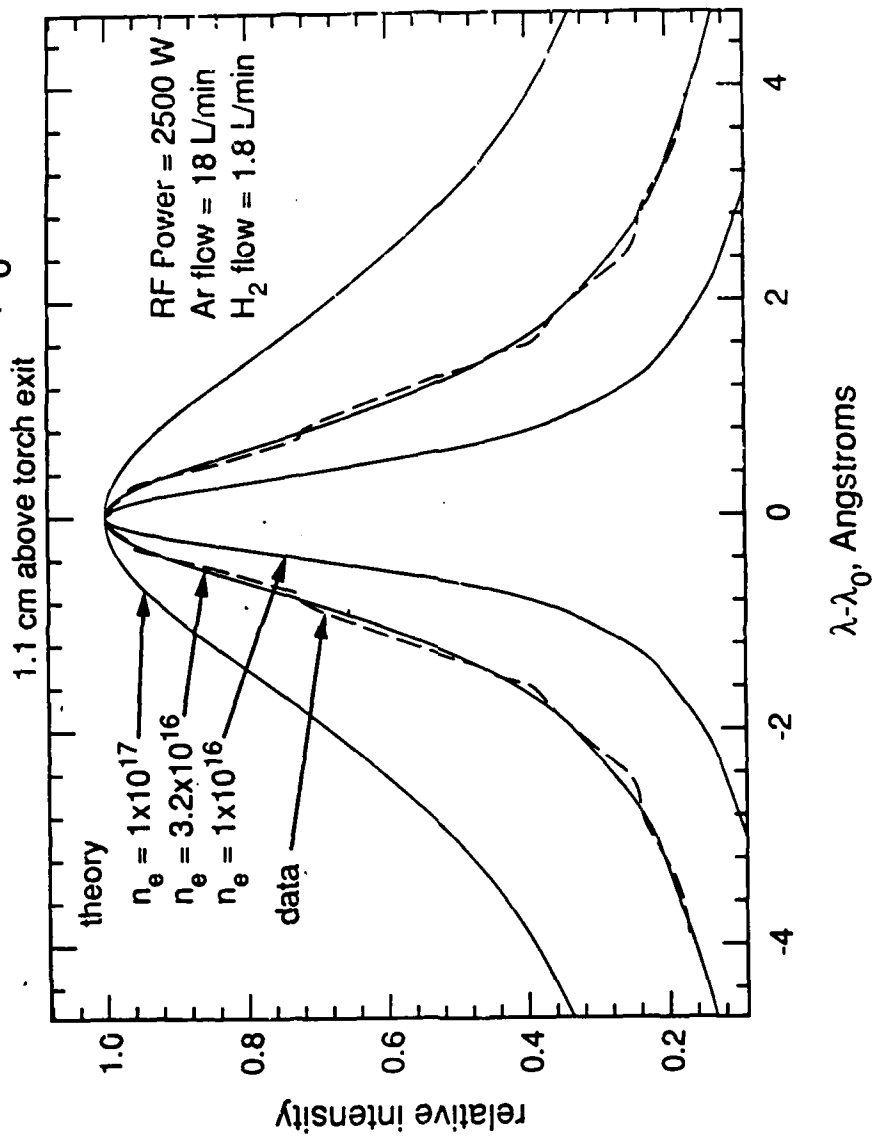

Figure 12. Initial results for spatially resolved measurement of electron density using Stark-broadened LIF.

Fundamental studies of free radicals are directly relevant to combustion and propulsion science. The concept of a laser photolysis shock tube originated in our laboratory, and the facility we've built during this past year is the first of its type. The shock tube is now fully operational, and results for reaction rate constants and absorption coefficients have been obtained and submitted for publication.

Discussion

The objective of this research is to establish an improved means of studying the properties of gases at high temperatures relevant to combustion science. Of particular interest are the spectroscopic and kinetic properties of radical species which play a critical role in many high temperature processes. Our strategy is to combine the shock tube's virtue of producing a controlled sample of high temperature gas, through gasdynamic heating, with the ability of an intense UV excimer laser to instantaneously photodissociate many stable species to free radicals. The shock tube used is of the conventional pressure-driven design, and the laser photolysis is carried out behind reflected shock waves using either transverse or end-on illumination through a transparent end wall. A schematic diagram of the apparatus is provided in Fig. 13.

An essential part of the research strategy is the use of sensitive and quantitative diagnostics to monitor the levels and time histories of the species present. This is done with two types of absorption diagnostics, one based on a tunable cw ring dye laser source and the other based on an atomic resonance lamp. The laser source is generally employed for the detection of molecular species, while the resonance lamp is well-suited for detection of atoms. Our laboratory has been active in the development of such diagnostics over the past 15 years, and hence the capability for detection of many interesting species is already available.

Following construction of the shock tube and a special laser photolysis test section to accommodate optical ports for both illumination and detection beams, we have begun to characterize the capabilities of the excimer laser, operating at 193 nm, to photodissociate candidate seed species at elevated temperatures. In general, our goal is to establish optimum seed materials for generating the radical species of interest. For example, what is the optimum source for generating H, N, C or O atoms, and for generating molecular radicals such as NH, CN, CH and OH? With such sources identified, we can begin to study the spectroscopic properties of these radicals at high temperatures and the rates of specific elementary reactions.

LASER PHOTOLYSIS SHOCK TUBE FOR FUNDAMENTAL STUDIES OF COMBUSTION RADICALS

- EXCIMER PHOTOLYSIS PROVIDES CONTROLLED POOL OF RADICALS IN SHOCK-HEATED GASES

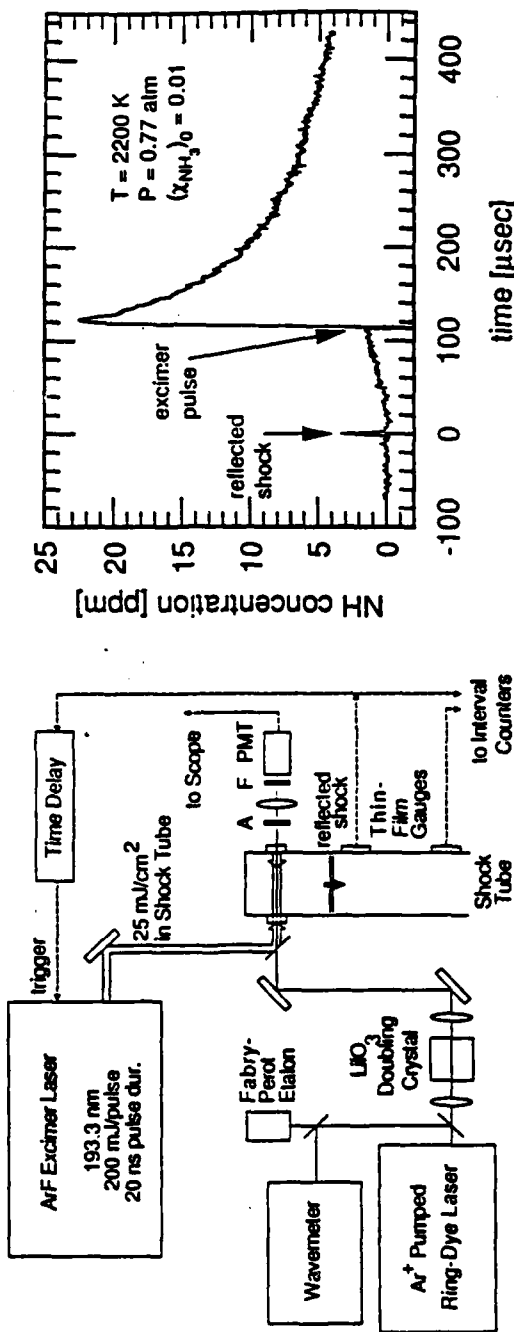

- PROVIDES FIRST-TIME ACCESS TO MANY CRITICAL COMBUSTION SPECIES
- ENABLES FUNDAMENTAL SPECTROSCOPIC STUDIES OF RADICALS AT HIGH TEMPERATURES
- ENABLES FUNDAMENTAL KINETICS STUDIES OF RADICALS AT HIGH TEMPERATURES

Figure 13. Schematic diagram and sample results for laser photolysis production of NH in a shock-heated NH₃-Ar mixture at 2200K.

An example of early work to produce NH using photolysis of NH_3 is included in Fig. 13. The time history clearly shows the instantaneous production of a low level of NH and the ability of our laser-based absorption system to quantitatively detect ppm levels of such radicals. Several kinetic and spectroscopic studies are currently underway, and two papers have already been prepared for publication (see Section 3.2, papers 15 and 17).

Although this project has only been underway a short time, the potential of the facility for important scientific contributions is already well established. We expect that the concept will be quickly accepted and implemented by other researchers in the high temperature physical chemistry community.

2.7 Flow Imaging Hardware/Software

Summary

An important part of our imaging diagnostics research is our effort to improve the performance of solid-state camera systems and to streamline their coupling to laboratory computers so as to facilitate user-friendly operation. This is a continuing effort, since both the camera technology available and our understanding of how to optimize a fluorescence imaging system are still evolving. During the past year, we've been actively involved with three separate new camera systems, and we've made good progress in assembling these systems into working cameras for PLIF experimentation. These cameras are based on different designs and have different capabilities: (1) a video-based CCD array camera, with high spatial resolution (610×244 pixels) and a fixed 30 or 60 Hz framing rate; (2) a 128×128 pixel photodiode array camera, with variable framing rate (to 250 Hz) and frame-on-demand capability; and (3) an image converter camera capable of storing a limited number of low-resolution images at up to 20 million frames per sec. The first two systems are now fully operational and are being used in diagnostics research projects; the high framing rate camera is still undergoing checkout and installation. In addition to these camera, we've invested a considerable effort in custom software to provide user-friendly data acquisition programs compatible with commercial frame-grabber technology. Finally, we've designed and fabricated a new optical system for collecting fluorescence emission which provides much improved light-gathering efficiency at UV wavelengths.

Discussion

In our early work with PLIF imaging, which began in 1981, we were forced to assemble a one-of-a-kind intensified camera and display system, but now most of the

elements of such systems are readily available, though not as complete ready-to-use packages. In the meantime, we've learned, for example, that a single-plate intensifier is generally superior to a dual-plate intensifier for typical PLIF photon signal levels. Also we now understand more clearly the trade-offs between the primary camera characteristics (namely framing speed, pixel size, fill factor, number of pixels, electrical noise, quantum efficiency and spectral response) and critical experimental constraints (size of region to be imaged, expected fluorescence level, wavelength and duration of signal). As regards optical efficiency, we've learned that direct fiberoptic coupling of the intensifier to the camera is greatly superior to lens coupling, and we've found that spatial resolution can be enhanced through use of a tapered fiberoptic bundle between the intensifier and the array. With regard to optical systems for collecting the PLIF emission, we've found that considerable care is needed to obtain the optimum compromise between spatial resolution and light-gathering efficiency.

An important conclusion of our work has been that no one camera system design is superior for all applications, and accordingly we've divided our developmental effort to allow separate systems optimized for high spatial resolution, high framing rate, variable (rather than fixed) framing rate, and for compatibility with video-based technology. In most cases, the primary difference between these systems is the camera (array sensor and control electronics), since the intensifier and tapered fiber bundles are generally interchangeable. The lab computer and much of the associated software usually can be the same. This parallel development path gives us considerable flexibility in our applications-oriented experiments as well as providing valuable hands-on experience with several state-of-the-art camera components.

Our progress in the areas of general imaging hardware, solid-state cameras, and image acquisition/processing software is described briefly below.

General Image Acquisition Hardware

During this year we have designed and assembled a new optical collection system for use at ultraviolet wavelengths. The design, which employs reflective optics in a Cassegrain telescope configuration, was carried out using a modern computer-based optics design package. Commercially available components were selected to minimize the overall cost. The resulting system is a compact F/1.1, 95 mm focal length package optimized for imaging with finite conjugate ratios (object size:image size) of about 10:1. This new collection system provides a gain in collection efficiency of about 20 over our previous UV lens system.

A second project has been to assemble a fast-gated intensifier system which will be needed in our velocity imaging research. This single-stage microchannel plate intensifier (ITT 4111) enables shot-noise-limited images at low light levels and can be gated on and off in about 10 nsec. The intensifier output is efficiently coupled to the camera arrays using a fiberoptic coupler, chosen such that the obtainable spatial resolution is not limited by the coupler.

A third project has involved development of a new data acquisition system based on frame-grabber technology. In brief, the frame-grabber (Data Translation 2851 or 2861), hosted by an IBM-AT class lab computer, digitizes and stores the analog signal output by the solid-state cameras. The frame-grabber supports acquisition of both video and non-standard (i.e., non-interlaced, $N \times M$ array) formats, and can acquire individual frames or n -frame averages. Non-standard frame sequences can also be acquired, with the framing rate currently limited by the camera systems rather than the frame grabber. Image processing is supplemented by an auxiliary frame processor (Data Translation 2858), which also provides the capability to perform real time video frame averaging. Preliminary processing can be done on the AT, while more complex processing can be done via our Ethernet link to the Sun/Pixar image processing computer.

Cameras

During this year, work has progressed on three new camera systems: a video-based CCD system, a variable-framing-rate 128×128 photodiode array camera, and a high-speed image converter camera. These new cameras each offer distinctive characteristics which complement our two existing cameras (an intensified 100×100 photodiode array, with variable framing rate; and a 384×576 high-resolution unintensified CCD array).

The new CCD camera is based on an Amperex NXA-1061 488×610 frame transfer CCD array. This camera is one of several currently available solid-state video cameras, but it has superior noise characteristics relative to other choices, and most importantly it was the only CCD array available with an attached optical fiber stub. This feature is essential for efficient coupling, through a tapered fiber bundle, to an intensifier tube. Distinguishing characteristics of this camera are:

- Operates under RS-170 video standard, allowing easy interfacing with commercially available video processing hardware and software
- Frame transfer format, so that entire active region is exposed at once
- 244×610 pixels, 18×11 microns, with 95% active area

- Operates at fixed 30 or 60 Hz framing rate
- Low camera noise (< 1000 electrons RMS) without cooling

The new 128×128 photodiode array camera is a Reticon system. Although the number of pixels is lower than that of the CCD camera, so that images have poorer spatial resolution, the Reticon camera has three features which are essential in certain experiments:

- Large (60 micron) pixels, needed for very low light levels
- Adjustable framing rate, up to 250 Hz in full-frame format
- True frame-on-demand capability

Frame-on-demand means that the camera can be reset, exposed, and read out immediately following a trigger pulse which occurs anywhere in time, i.e., it is asynchronously triggerable. This feature is required for study of truly transient events, such as our current shock tube and shock tunnel experiments.

The third new camera system is an Imacon 790 image converter camera. This is a commercial system which enables burst mode recording at high rates (up to 20 million frames per sec). The system is still undergoing checkout and minor modifications to allow triggering of the recording times synchronous with the illumination laser.

Software

A user-friendly data acquisition program with the following characteristics has been written around the Data Translation 2851 and 2858 frame grabber and auxiliary processor boards:

- Majority of program written in FORTRAN for easy readability/modification by most users in lab; some memory intensive data movement done in assembly language for speed
- Supports video (480×512) and non-standard (N×M up to 512×512) frame acquisition and processing
- Can perform simple real math image processing (crucial in some experiments, e.g. velocity imaging, to determine whether desired information is being captured or not)
- Has user-definable data storage and recall formats

- Supports macro routines for commonly used command and image processing sequences
- Allows rapid generation of presentation quality color tables
- Has minimal host environment dependence: requires AT with at least 180 K system memory to load, additional 256 K or more available memory in extended memory or system memory; doesn't require co-presence of DT-2858, but will use if installed.

3.0 PRESENTATIONS AND PUBLICATIONS

3.1 Presentations (10/87 — 10/88)

1. D. L. Hofeldt, M. G. Allen and R. K. Hanson, "Instantaneous Two-Dimensional Multiple Particle-Sizing Diagnostic," presented at 24th JANNAF Combustion Meeting, Monterey, CA, Oct. 6, 1987.
2. I. van Cruyningen, P. H. Paul and R. K. Hanson, "Turbulent Flowfield Interpretation Through Processing of PLIF Images," paper presented at fall meeting of Western States Section/The Combustion Institute, Honolulu, HI, Nov., 1987.
3. D. L. Hofeldt, M. G. Allen and R. K. Hanson, "Instantaneous Two-Dimensional Multiple Particle-Sizing Diagnostic," presented at ICALEO '87 Symposium on Flow and Particle Diagnostics, San Diego, CA, Nov. 12, 1987.
4. P. H. Paul, I. van Cruyningen and R. K. Hanson, "High-Resolution Planar Laser-Induced Fluorescence Imaging of Jets," presented at APS Fluid Dynamics Meeting, Eugene, OR, Nov. 22-25, 1987.
5. R. K. Hanson, "Laser-Based Diagnostics for Gaseous Flows," invited paper presented at workshop on Diagnostics for Ground-Based NASP Testing, West Palm Beach, Florida, Feb. 3, 1988.
6. R. K. Hanson, "Digital Fluorescence Imaging in Gaseous Flows," invited Visiting Lecturer, Univ. of Houston, Houston, TX, Feb. 25, 1988.
7. K. Kohse-Höinghaus, D. F. Davidson and R. K. Hanson, "Quantitative NH_2 Laser-Absorption Diagnostic for Shock Tube Kinetics Studies," Paper 88-55 presented at the spring meeting, Western States Section/The Combustion Institute, Salt Lake City, Utah, March 21-22, 1988.
8. R. K. Hanson, "Applications of PLIF Imaging to Supersonic Flows," invited presentation at Eleventh Sandia Cooperative Group Meeting, Livermore, CA, March 29-30, 1988.
9. P. H. Paul, J. J. Seitzman, L. M. Cohen, B. K. McMillin and R. K. Hanson, "Planar Laser-Induced Fluorescence Imaging in Supersonic Flows," invited paper presented at CLEO '88, Anaheim, CA, April 1988.

10. R. K. Hanson, P. H. Paul and J. M. Seitzman, "Digital Fluorescence Imaging of Gaseous Flows," invited paper presented at Materials Research Society - Reno Meeting, April 5-7, 1988.
11. J. M. Seitzman, P. H. Paul and R. K. Hanson, "Digital Imaging of Laser-Ignited Combustion," AIAA reprint 88-2775; presented at AIAA Thermophysics, Plasmadynamics and Lasers Conference, San Antonio, Texas, June 27-29, 1988.
12. R. K. Hanson, A. Y. Chang, and D. F. Davidson, "Modern Shock Tube Methods for Chemical Studies in High Temperature Gases," AIAA reprint 88-2712; presented at AIAA Thermophysics, Plasmadynamics and Lasers Conference, San Antonio, Texas, June 27-29, 1988.
13. A. J. Dean, D. F. Davidson, and R. K. Hanson, "CH Diagnostic for Shock Tube Kinetic Studies Using Laser Absorption at 431 nm," poster paper presented at 22nd Symposium (International) on Combustion, Seattle, Aug. 15-19, 1988.
14. P. H. Paul, J. M. Seitzman, M. P. Lee, B. McMillin and R. K. Hanson, "Imaging of Supersonic Flows Using Planar Laser-Induced Fluorescence," poster paper presented at 22nd Symposium (International) on Combustion, Seattle, Aug. 15-19, 1988.
15. R. Hanson, "Advanced Diagnostic Techniques for Testing NASP Engine Modules," invited presentation at workshop on NASP/ETF program, Arnold AFB, TN, Aug. 24-25, 1988.
16. K. Kohse-Höinghaus, D. F. Davidson and R. K. Hanson, "Quantitative NH₂ Laser-Absorption Diagnostic for Shock Tube Kinetics Studies," submitted to J. Quant. Spectrosc. and Radiat. Transfer, Sept., 1988.
17. J. D. Mertens, A. Y. Chang, R. K. Hanson and C. T. Bowman, "Decomposition Kinetics of HNCO at High Temperatures," to be presented at Western States Section/The Combustion Institute, Laguna Beach, CA, October 1988.
18. A. J. Dean, D. F. Davidson and R. K. Hanson, "Development and Application of CH Laser Absorption Diagnostic for Shock Tube Kinetic Studies," to be presented at Western States Section/The Combustion Institute, Laguna Beach, CA, October 1988.
19. R. K. Hanson, "Laser-Based Spectroscopic Measurements in High Temperature Gases," invited paper to be presented at 1988 Annual Meeting of the Optical Society of America, Santa Clara, CA, Oct. 31-Nov. 4, 1988.

20. R. K. Hanson, "Laser-Based Fluorescence Imaging of Gaseous Flows," invited paper to be presented at ICALEO '88, Santa Clara, CA, Oct. 31-Nov. 4, 1988.

3.2 Publications (10/87 — 10/88)

1. Y. Asano, D. S. Baer and R. K. Hanson, "Substrate Temperature Dependence of SiH Concentration in Silane Plasmas for Amorphous Silicon Film Deposition," *J. Non-Cryst. Solids* **94**, 5-10, 1987.
2. Y. Asano, D. S. Baer, R. Hernberg and R. K. Hanson, "Radial Distribution Measurement of SiH in a Low Pressure Silane Plasma," *Plasma Chemistry and Plasma Processing* **8**, 1-8 (1988).
3. D. L. Hofeldt, M. G. Allen and R. K. Hanson, "Instantaneous Two-Dimensional Multiple Particle-Sizing Diagnostic," ICALEO '87 Symposium on Flow and Particle Diagnostics, pp. 182-189, 1987; presented at ICALEO '87, San Diego, CA, Nov. 12, 1987.
4. U. Vandsburger, J. M. Seitzman and R. K. Hanson, "Visualization Methods for the Study of Unsteady Non-Premixed Flame Structure," *Comb. Sci. and Technology*, in press.
5. R. K. Hanson, "Combustion Diagnostics: Planar Flowfield Imaging," *Twenty-First Symposium (International) on Combustion*, The Combustion Institute, 1677-1691 (1986).
6. M. G. Allen and R. K. Hanson, "Digital Imaging of Species Concentration Fields in Spray Flames," *Twenty-First Symposium (International) on Combustion*, The Combustion Institute, 1755-1762 (1986).
7. E. C. Rea, Jr., A. Y. Chang and R. K. Hanson, "Rapid Laser Wavelength Modulation Spectroscopy Applied as a Fast Temperature Measurement Technique in Hydrocarbon Combustion," *Applied Optics*, in press, to appear Nov. 1988.
8. E. C. Rea, Jr., A. Y. Chang and R. K. Hanson, "Rapid-Tuning Laser Absorption Diagnostics for Shock Tube Flows," *Shock Tubes and Waves*, ed. H. Gronig, (VCH Publishers) 863-869 (1987); presented at 16th International Symposium on Shock Tubes and Waves, Aachen, July 1987.

9. B. Hiller and R. K. Hanson, "Simultaneous Planar Measurements of Velocity and Pressure Fields in Gas Flows Using Laser-Induced Fluorescence," *Applied Optics* 27, 33-48 (1988).
10. B. Hiller, P. H. Paul and R. K. Hanson, "Image-Intensified Photodiode Array as a Fluorescence Detector in CW-Laser Experiments," *Review of Scientific Inst.*, in review.
11. R. K. Hanson and J. M. Seitzman, "Planar Fluorescence Imaging in Gases," Chap. II-5-G in *Handbook of Flow Visualization*, ed. W.-J. Yang, Hemisphere Pub. Corp., in press.
12. R. K. Hanson, P. H. Paul and J. M. Seitzman, "Digital Fluorescence Imaging of Gaseous Flows," *Materials Research Society Symposium Proceedings (MRS, Pittsburgh, PA)*, Vol. 117, pp. 227-237, 1988; presented at MRS - Reno Meeting, April 5-7, 1988.
13. J. M. Seitzman, P. H. Paul and R. K. Hanson, "Digital Imaging of Laser-Ignited Combustion," AIAA reprint 88-2775; presented at AIAA Thermophysics, Plasmadynamics and Lasers Conference, San Antonio, Texas, June 27-29, 1988.
14. R. K. Hanson, A. Y. Chang, and D. F. Davidson, "Modern Shock Tube Methods for Chemical Studies in High Temperature Gases," AIAA reprint 88-2712; presented at AIAA Thermophysics, Plasmadynamics and Lasers Conference, San Antonio, Texas, June 27-29, 1988.
15. D. F. Davidson, A. Y. Chang and R. K. Hanson, "Laser Photolysis Shock Tube for Combustion Kinetics Studies," *Twenty-Second Combustion Symposium (International) on Combustion*, The Combustion Institute, in press.
16. P. H. Paul, M. P. Lee, B. K. McMillin, L. M. Cohen and R. K. Hanson, "Planar Laser-Induced Fluorescence Imaging in Supersonic Flows," submitted to AIAA 27th Aerospace Sciences Meeting, Reno, January 1988.
17. K. Kohse-Höinghaus, D. F. Davidson and R. K. Hanson, "Quantitative NH₂ Laser-Absorption Diagnostic for Shock Tube Kinetics Studies," submitted to *J. Quant. Spectrosc. and Radiat. Transfer*; also poster paper presented at 22nd Symposium (International) on Combustion, Seattle, Aug. 15-19, 1988.
18. P. H. Paul, M. P. Lee and R. K. Hanson, "Molecular Velocity Imaging Using a Pulsed Laser Source," submitted to *Optics Letters*, Sept. 1988.

4.0 PERSONNEL

Individual researchers supported by the program are listed below. All the work has been carried out in the High Temperature Gasdynamic Laboratory, in the Department of Mechanical Engineering, under the supervision of Professor R. K. Hanson.

Research Associates

Dr. P. H. Paul

Dr. D. F. Davidson

Dr. K. Kohse-Höinghaus (visiting scientist sponsored by DFVLR)

Graduate Research Assistants

Jerry Seitzman

Mike Lee

Larry Cohen

Ike van Cruyningen

Doug Baer

Brian McMillin

Albert Chang

Dave Hofeldt

5.0 REFERENCES

1. M. P. Lee and R. K. Hanson, "Calculations of O₂ Absorption and Fluorescence at Elevated Temperatures for a Broadband Argon Fluoride Laser Source at 193 nm," *J. Quant. Spectroscopy and Rad. Transfer* **36**, 425-440 (1986).
2. M. P. Lee, P. H. Paul and R. K. Hanson, "Laser Fluorescence Imaging of O₂ in Combustion Flows Using an ArF Laser," *Optics Letters* **11**, 7-9 (1986).
3. M. P. Lee, P. H. Paul and R. K. Hanson, "Quantitative Imaging of Temperature Fields in Air Using Planar Laser-Induced Fluorescence of O₂," *Optics Letters* **12**, 75-77, 1987.
4. B. Hiller, J. C. McDaniel, E. C. Rea, Jr., and R. K. Hanson, "Laser-Induced Fluorescence Technique for Velocity Field Measurements in Subsonic Gas Flows," *Optics Letters* **8**, 474-476 (1983).
5. B. Hiller and R. K. Hanson, "Two-Frequency Laser-Induced Fluorescence Technique for Rapid Velocity-Field Measurements in Gas Flows," *Optics Letters* **10**, 206-208 (1985).
6. B. Hiller, L. M. Cohen and R. K. Hanson, "Simultaneous Measurements of Velocity and Pressure Fields in Subsonic and Supersonic Flows through Image-Intensified Detection of Laser-Induced Fluorescence," *Flow Visualization IV*, ed. C. Veret, (Hemisphere Pub. Corp.), pp. 173-178 (1987)
7. B. Hiller and R. K. Hanson, "Simultaneous Planar Measurements of Velocity and Pressure Fields in Gas Flows Using Laser-Induced Fluorescence," *Applied Optics* **27**, 33-48 (1988).
8. R. K. Hanson, P. H. Paul and J. M. Seitzman, "Digital Fluorescence Imaging of Gaseous Flows," *Materials Research Society Symposium proceedings (MRS, Pittsburgh, PA)*, Vol. 117, pp. 227-237, 1988; presented at - Reno Meeting, April 5-7, 1988.

Approved for Release by NSA on 05-08-2011 pursuant to E.O. 13526