

GAO

United States General Accounting Office  
Report to the Honorable  
Lowell P. Weicker, Jr., U.S. Senate



December 1988

AD-A202 773

# LIGHT HELICOPTER PROGRAM

## Risks Facing the Program Raise Doubts About the Army's Acquisition Strategy

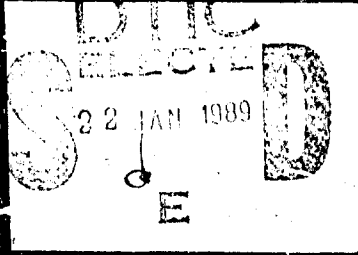

About Our New Cover

The new color of our report covers represents the latest step in GAO's efforts to improve the presentation of our reports.

1

**GAO**

United States  
General Accounting Office  
Washington, D.C. 20548

**National Security and  
International Affairs Division**

B-222896

December 23, 1988

The Honorable Lowell P. Weicker, Jr.  
United States Senate

Dear Senator Weicker:

We have completed our review of the Army's Light Helicopter program, which we conducted at your request. We have issued two reports and briefed your staff on several occasions regarding the program's progress in response to your original request of April 22, 1986, and subsequent oral requests for follow-on work made by your office. This report responds to an oral request made by your office on October 15, 1987.

After several changes in the program's focus and approach, in June 1988 the Department of Defense approved the Light Helicopter program's entry into the demonstration and validation phase of development. This report focuses on (1) changes and risks in the program's cost estimates and technology development, (2) changes in the program's acquisition strategy, and (3) progress made toward achieving program goals. The report contains recommendations to the Secretary of Defense.

We are sending copies of the report to interested parties, including the Chairmen of the House and Senate Committees on Armed Services and Appropriations and the Secretaries of Defense and the Army.

This report was prepared under the direction of Richard Davis, Senior Associate Director. Other major contributors are listed in appendix I.

Sincerely yours,

*Frank C. Conahan*

Frank C. Conahan  
Assistant Comptroller General

**DTIC**  
ELECTRONIC  
22 JAN 1989

Accession For	
NTIS GRA&I	<input checked="" type="checkbox"/>
DTIC TAB	<input type="checkbox"/>
Unannounced	<input type="checkbox"/>
Justification	
By _____	
Distribution/	
Availability Codes	
Dist	Avail and/or Special
<b>A-1</b>	

89 1 10 059

# Executive Summary

---

## Purpose

The Light Helicopter (LHX) program is intended to provide the Army with a new generation of scout and attack helicopters that will replace many aging helicopters. The LHX program, estimated to cost over \$40 billion, is among the Army's largest acquisitions and will be the Army's primary aircraft development and production program into the next century. The program faces significant development risks as the Army begins demonstration and validation of the LHX's technologies.

Senator Lowell Weicker requested that GAO assess the program's progress toward achieving its goals, the technical and cost risks facing the program, and the Army's strategy for developing the LHX.

---

## Background

The LHX is intended to be a lightweight helicopter capable of performing multiple missions against advanced enemy air defenses of the 1990s. The Army sees the LHX as the mainstay of its aviation fleet into the next century. It intends the LHX to perform both scout and attack helicopter functions, including (1) performing battlefield reconnaissance, (2) finding and attacking armored targets, (3) striking deep against enemy positions, and (4) engaging enemy helicopters in air combat. These capabilities, together with the goal of light weight, make the LHX a very advanced aircraft—on a par with the Air Force's Advanced Tactical Fighter. (SBU)

In the recently approved demonstration and validation phase, two teams of two contractors each will compete for development of the LHX airframe and avionics, with a winning team to be selected in about 2 years to proceed with full-scale development.

---

## Results in Brief

The LHX program's original goals of meeting performance requirements with a lightweight, low-cost, single-seat aircraft have proven too demanding. Technological limits caused the Army to abandon the single-seat aircraft in favor of a two-seat aircraft. After a series of cost and weight increases, the Army significantly scaled the LHX program back by deleting the utility version, reducing total quantities from 4,292 to 2,096, and trading off performance requirements to lower aircraft weight and cost.

Even with these changes, the LHX program faces considerable risks, including (1) significant technical hurdles, particularly regarding the LHX's mission equipment, (2) indications that the weight goal will not be met, and (3) the likelihood of increasing costs.

To lower LHX research and development costs, the Army has chosen an acquisition strategy for the LHX that eliminates the test and evaluation of competitive prototypes before selecting a winning contractor team and entering full-scale development. This strategy may not provide for the adequate resolution of program risks and validation of cost estimates in time for these key decisions.

The current LHX acquisition strategy runs counter to acquisition guidance generally applicable to the Department of Defense (DOD), which supports competitive prototyping. DOD and LHX program officials agree that the strategy of competitive prototyping is preferable but believe that such an approach is not affordable given the limited amount of research and development funds available. The fact that a program of such significance to the Army does not warrant the funds necessary to pursue such an acquisition strategy may mean that DOD should reassess the priorities of its research and development projects.

In addition, the Army's use of "flyaway" costs—a subset of procurement costs—to set LHX cost goals may not provide a sound basis for controlling and measuring costs because flyaway costs cover only about 65 percent of expected procurement costs. A more inclusive control measure may be necessary to provide needed oversight to all key cost elements and a better indicator of expected procurement costs.

---

## Principal Findings

---

### Technical Risks

Significant technical risks remain to be overcome, including the development of advanced technology such as (1) more advanced threat sensors than those of the Army's current attack helicopters; (2) high-speed, high-capacity integrated circuits to process and integrate flight, threat, and other critical data; and (3) an all-composite (non-metal) airframe designed to be difficult to detect by threat sensors.

---

### Weight Goal May Not Be Met

The Army currently estimates the LHX's empty weight at about 8,000 pounds and thus must make additional reductions to reach the 7,500-pound goal. The current estimate excludes the weight of planned improvements and tactical kits—amounting to several hundred pounds—that must also be offset if the weight goal is to be achieved. In

---

addition, the Army must allow for about 5- to 10-percent weight growth during development, which normally occurs in aircraft programs.

---

### Costs Are Likely to Increase

The Army estimates flyaway costs at \$8.2 million per LHX, and more trade-offs are needed to meet the unit flyaway cost goal of \$7.5 million (constant fiscal year 1988 dollars). However, program costs are still likely to increase because of (1) uncertainty in the cost of the LHX's avionics and (2) potential weight increases, which translate into cost increases. In addition, recent procurement funding projections do not provide enough procurement money to produce the LHX at planned rates. Reduced production rates will extend the program and will increase costs.

### Flyaway Costs Provide Incomplete Cost Picture

The estimated unit procurement cost for the LHX is \$12.7 million (constant fiscal year 1988 dollars).<sup>1</sup> Flyaway costs are lower than procurement costs because they exclude such items as initial spares, support equipment, and items procured on less than a one-for-one basis with the aircraft. Similarly, a significant planned improvement—an advanced targeting system—is excluded from flyaway costs. These exclusions point out a major shortcoming of flyaway cost as a measurement tool: flyaway costs do not reflect the expected cost of an LHX equipped for its primary mission, which would likely include several kits and the advanced targeting sensor.

### Acquisition Strategy Is Risky

To comply with DOD guidance, the Army reduced estimated LHX research and development costs from \$5.4 billion to \$3.9 billion (escalated dollars) by deleting the test and evaluation of competitive prototypes from the demonstration and validation phase. Competition under the current strategy will consist primarily of paper studies with preliminary demonstrations of selected subsystems. This strategy may not provide decisionmakers with critical information—such as demonstrated performance and validation of cost estimates—when needed for contractor selection and the full-scale development decision. This information is pivotal for the LHX program given the advanced technology involved and the demonstrated impact of cost growth on the program's affordability. A competitive prototype acquisition strategy would provide this information when needed.

---

<sup>1</sup>Research and development costs are excluded from both procurement and flyaway costs.

Alternative acquisition strategies are available that are not as costly as the previous LHX strategy but can provide better information for decisions than the current strategy. One alternative would involve the competitive prototyping of only key mission equipment elements aboard surrogate aircraft during demonstration and validation. Another alternative would involve ending competition as planned but deferring the full-scale development decision until prototype mission equipment is demonstrated.

---

## Recommendations

GAO recommends that the Secretary of Defense take the following actions:

- Reassess whether the LHX warrants a higher priority for more research and development funds within projected resources to pursue an acquisition strategy that provides for the test and evaluation of competitive prototypes, particularly regarding mission equipment, before selecting a winning contractor team and committing the program to full-scale development.
- If the current acquisition strategy is pursued, separate the decision to select the winning contractor from the decision to commit the program to full-scale development by postponing the full-scale development decision until it can be made on the basis of the winning contractor's demonstrated performance with prototypes.
- Set program cost goals around more meaningful measurements than fly-away costs, such as the cost of an LHX equipped for its primary mission, the unit procurement cost, or both.

---

## Agency Comments

DOD officials agreed in principle with GAO's conclusions and recommendations. They agreed that a competitive prototyping strategy would be preferable for the LHX but noted that, while the LHX's priority among research and development efforts has been and will continue to be under reassessment, at this time DOD cannot afford such a strategy. DOD officials believe that technical risks are manageable and noted that an extensive risk reduction effort has already taken place on the program. They stated that if, at the time of the full-scale development decision, available information is insufficient or if technical risks are deemed too high to proceed into full-scale development, they will extend the demonstration/validation phase.

# Contents

---

<b>Executive Summary</b>		2
<hr/>		
<b>Chapter 1</b>		8
<b>Introduction</b>		
	The LHX's Mission	9
	LHX's Significance to Future Army Aviation	10
	Commonality With Air Force and Navy Programs	12
	Development Efforts to Date	12
	Objectives, Scope, and Methodology	13
<hr/>		
<b>Chapter 2</b>		14
<b>More Trade-Offs Will Be Needed to Balance Technical Risks With Cost and Weight</b>		
	Weight and Cost Goals Cause Performance Trade-Offs	14
	Technical Hurdles Lead to Two-Seat LHX	16
	Technical Risks Still Face the LHX	17
	Weight Goal May Be Difficult to Achieve	18
	Conclusions	20
	Agency Comments	20
<hr/>		
<b>Chapter 3</b>		21
<b>Difficulties in Controlling Program Costs Likely to Continue</b>		
	Program Substantially Cut Back Following Period of Cost Increases	21
	Program Costs Are Likely to Increase	23
	Flyaway Costs May Not Be Meaningful as a Cost-Measurement and Control Mechanism	25
	Erosion of Savings Goals for Operation and Support Costs	27
	Conclusions and Recommendation	27
	Agency Comments	28
<hr/>		
<b>Chapter 4</b>		29
<b>Acquisition Strategy Reduces Competition and Provides Less Information for a Full-Scale Development Decision</b>		
	Demonstration/Validation Phase Shortened to Save Money	29
	Current Acquisition Strategy Runs Counter to Defense Policies and Practices	31
	Acquisition Strategy May Also Be Modified to Eliminate Dual Sourcing	33
	Compatibility With Engine Development	33
	Conclusions and Recommendations	34
	Agency Comments	34
<hr/>		
<b>Appendix</b>		
	Appendix I: Major Contributors to This Report	36

---

**Tables**

Table 3.1: History of the LHX Program's Cost Estimates	22
Table 3.2: History of the LHX Program's Estimated Procurement Quantities	22
Table 3.3: Changes Made to the LHX Program	23
Table 3.4: Production Rates for Army Helicopters Based on Projected Funding	25

---

**Figures**

Figure 1.1: Artist's Conception of the LHX Helicopter	10
Figure 1.2: LHX as Part of the Army's Modernized Aviation Fleet	11
Figure 4.1: Comparison of June 1988 and June 1987 Acquisition Strategies	30

---

**Abbreviations**

DOD	Department of Defense
GAO	General Accounting Office
LHX	Light Helicopter
VHSIC	Very High Speed Integrated Circuitry

# Introduction

The Army's Light Helicopter (LHX) program is to provide a fleet of new helicopters with the advanced capabilities to perform several new missions, such as air combat and fighting across battle lines, as well as existing anti-armor and reconnaissance missions. Estimated to cost over \$40 billion, the LHX is to replace several light helicopters that the Army considers too obsolete to meet the demands of the future battlefield. The LHX will be the Army's most technically advanced helicopter if it is to perform its missions and survive against the threat weaponry of the 1990s at its expected light weight. Critical to meeting its requirements is its mission equipment (avionics and sensors), which is as sophisticated as that of the Air Force Advanced Tactical Fighter now in development. In addition, the LHX airframe will be made from lightweight composite materials, as opposed to metal.

The viability and affordability of the LHX program have been actively debated within the Department of Defense (DOD), and the program has undergone significant changes since its inception in 1983. The LHX program was to address several goals in addition to meeting mission requirements: it was originally conceived as a program to focus several research and development efforts into a lightweight, multipurpose (scout, attack, and utility), single-seat helicopter that would be relatively inexpensive to buy and maintain. However, the mission requirements subsequently developed for the LHX were so demanding as to drive aircraft cost and weight up and to cause the Army to abandon the single-seat design. In the past 5 years, several key program issues have been debated and resolved. These include the following:

- Single-seat versus two-seat cockpit: The Army concluded that the pilot work load posed by the LHX's missions was too great for one person.
- Conventional helicopter versus tilt-rotor design: Independent studies ordered by DOD supported the conventional helicopter.
- Competition throughout development versus partial competition: DOD decided that budgetary constraints would not allow competition throughout the entire development.
- Conducting demonstration/validation versus proceeding directly into full-scale development: DOD decided that a demonstration/validation phase was necessary.

In addition to these developments, the LHX program has also gone through a period of significant cost and weight growth, reflecting attempts to meet the numerous mission requirements. In June 1988, DOD approved the program's entry into demonstration/validation as well as a program baseline that DOD believes is affordable. The approved baseline

reflects significant program changes, including cutting procurement quantities in half, deleting the utility version of the LHX, and reestablishing cost and weight goals while easing some mission requirements.

---

## The LHX's Mission

The LHX helicopter is to perform roles that are currently performed by both scout and attack helicopters. As a scout, the LHX will conduct missions, such as battlefield reconnaissance for ground commanders, during which the helicopter will fly over enemy territory and report on enemy positions. Because the LHX will be armed with the Hellfire antitank missile, it will be able to engage targets, if necessary, while conducting reconnaissance. Current scout helicopters are not so armed, although the Army is considering arming an existing scout helicopter with the Hellfire. As an attack helicopter, the LHX will be used to attack enemy tanks and armored vehicles as they advance toward U.S. ground forces. In addition, the Army intends to use the LHX to conduct deep attack missions behind enemy lines as part of the AirLand Battle doctrine and to conduct air combat operations against enemy helicopters. These latter missions are relatively new and are not performed by current helicopters.

---

## Description of Capabilities

To fulfill the LHX's requirements to be light and agile enough to perform scout missions, yet with the capabilities to perform anti-armor missions similar to those of the much heavier current attack helicopter, very sophisticated technology must be employed. The LHX is to increase combat effectiveness and battlefield survivability to defeat the threat of the mid-1990s and be capable of sustained operations both day and night and in adverse weather. Figure 1.1 shows an artist's conception of the LHX helicopter.

The key features of the LHX include the following:

Composite airframe: Using composite structures is intended to result in 20 percent less weight than metal structures.

Advanced target acquisition and night vision sensors: These sensors offer greater resolution and range and potential automation of some target acquisition tasks.

Advanced avionics architecture: Based on Very High Speed Integrated Circuitry (VHSIC) technology, the avionics will include a digital/optical flight control system, a wide-field-of-view helmet-mounted display, and

Figure 1.1: Artist's Conception of the LHX Helicopter

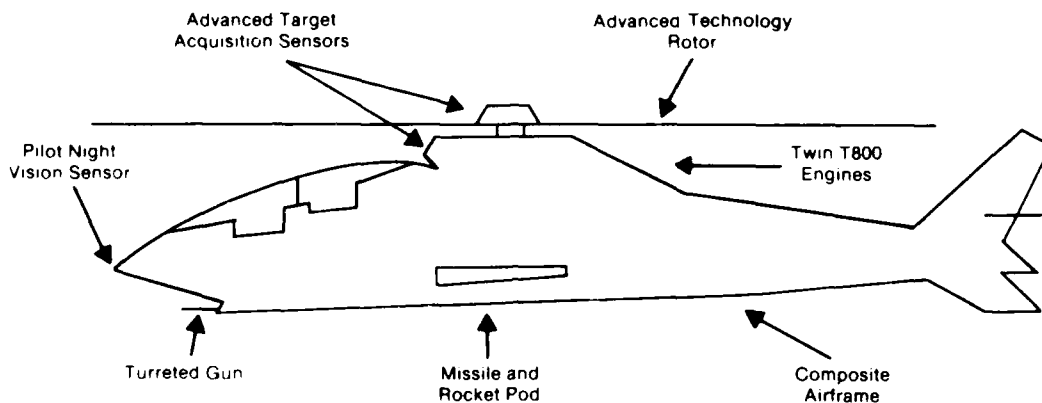

built-in diagnostics. VHSIC provides the large processing capacity needed by the avionics subsystems, which would otherwise require additional space and would increase weight substantially.

Survivability: Survivability is intended to be enhanced through the combination of an airframe designed for low observability together with advanced threat sensors and jammers.

Armament: The LHX is to be capable of handling varying combinations of existing weapons to meet mission needs, including Hellfire antitank missiles, Stinger air-to-air missiles, Hydra-70 rockets, and a turreted gun system.

## LHX's Significance to Future Army Aviation

The LHX, which is currently the only new helicopter development program the Army is undertaking, figures prominently in the Army's plans for its aviation fleet for the 1990s and beyond, according to the May 1988 Army Aviation Modernization Plan. It will eventually comprise a significant portion of the Army's aviation fleet, particularly in the attack and reconnaissance areas, as shown in figure 1.2.

The LHX is intended to address some of the key objectives of the aviation plan. The plan cites as the most significant aviation deficiency the limited ability of reconnaissance and attack aviation units to see the battlefield. The plan also states that effective reconnaissance, command and

Figure 1.2: LHX as Part of the Army's Modernized Aviation Fleet

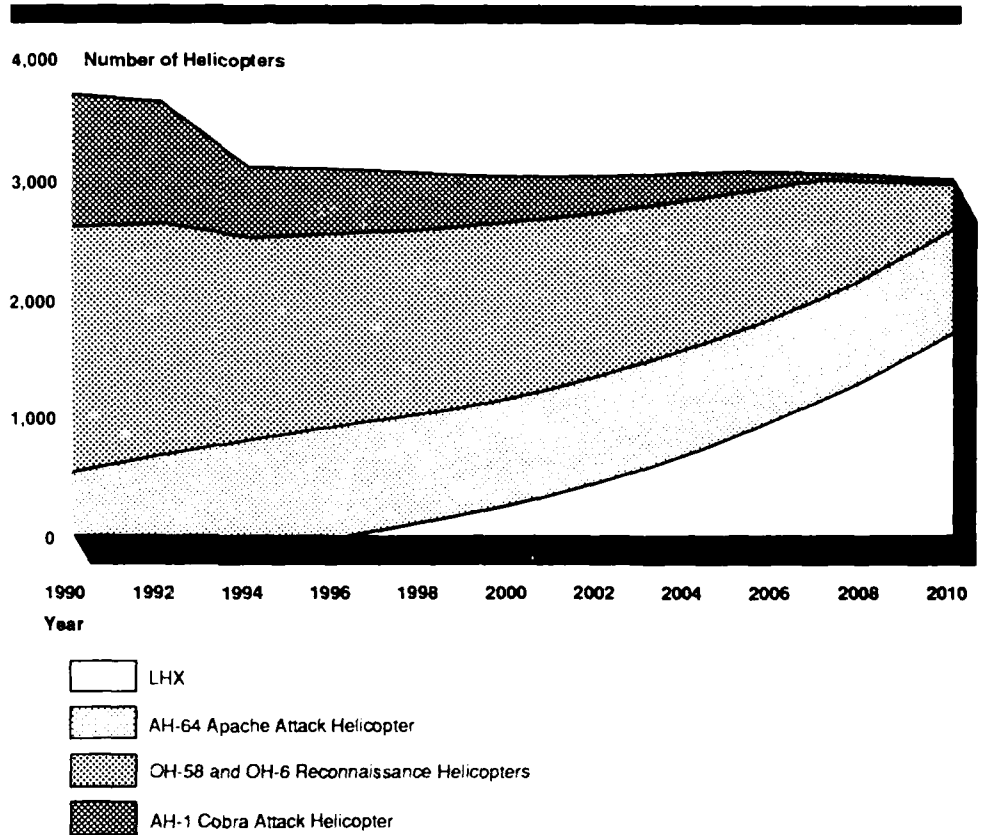

control, and target acquisition have become more important than aircraft speed and weapon system characteristics. The Army sees the LHX's capabilities as filling these voids. In addition, the Army wants to reduce its fleet size by retiring older helicopters that are no longer able to fight and survive on the battlefield. It sees the LHX as an opportunity to reduce fleet size (and consequently maintenance burden) while increasing war-fighting capabilities because the LHX's capabilities will enable a fewer number of LHXs to replace the older helicopters.

The aviation plan also calls for the continuous modernization of existing aircraft systems in order to incorporate advanced war-fighting technologies. Along these lines, the Army plans to incorporate LHX technologies into other helicopters to improve their capabilities as well. Specifically, the Army has begun to study the application of LHX avionics to fielded helicopters both from near-term and long-term standpoints, and it plans

to upgrade existing helicopters with LHX-common avionics technologies through multistage improvement programs.

## Commonality With Air Force and Navy Programs

The Army, the Navy, and the Air Force, at the direction of the Congress, have agreed to develop a common set of avionics modules that may be used for the LHX, the Navy's Advanced Tactical Aircraft, and the Air Force's Advanced Tactical Fighter. Since the development of the Navy aircraft precedes that of the Army and Air Force aircraft, the services have agreed that avionics modules of the Army and Air Force aircraft will be made common, and the Navy will subsequently upgrade its aircraft with the more advanced avionics. The services have formed a Joint Integrated Avionics Working Group to guide this process.

## Development Efforts to Date

From fiscal year 1983 through fiscal year 1988, LHX appropriations have totaled about \$463 million, which the Army applied to engine development and risk reduction and preliminary design efforts for the airframe and mission equipment. In fiscal year 1989, \$125 million was appropriated to support the LHX demonstration and validation effort, and \$56 million was appropriated to continue engine development.

LHX development is being conducted by teams of competing contractors. The airframe (including mission equipment) is being developed by two teams—one comprised of Bell Helicopter Textron and the McDonnell Douglas Helicopter Company and the other comprised of Boeing Helicopters and Sikorsky Aircraft. These contractors have been involved throughout the program, and the Army awarded demonstration/validation contracts to them in November 1988. The demonstration/validation contracts are scheduled to run for 23 months, after which the Army will select one of the teams to continue with LHX full-scale development and production. The first flight of a prototype LHX is scheduled for August 1993.

The LHX T800 engine was also competitively developed by two contractor teams—one team comprised of the Allison Gas Turbine Division of General Motors and the Garrett Engine Division of the Allied Signal Corporation and the other comprised of AVCO Lycoming and Pratt & Whitney. The engine program's development is further along than the airframe's. In October 1988, the Army selected the Allison/Garrett team as the winner, and that team will complete engine development and eventually split apart for dual source production.

## Objectives, Scope, and Methodology

Senator Lowell Weicker requested that we review the LHX program and provide information on the program as new developments occur. We have issued two previous reports to Senator Weicker on the LHX.<sup>1</sup> Our specific objectives in this review were to assess (1) changes and risks regarding cost estimates and technology development, (2) changes in the acquisition strategy, and (3) progress made in achieving program goals.

We reviewed documents relevant to the LHX program such as briefing charts, requests for proposals, detailed cost estimates, and independent studies of the airframe design, cost estimate, and acquisition strategy. We also interviewed officials from the Office of the Secretary of Defense, the Army, and contractors. We conducted our review at the Army's LHX program office located at the Army Aviation Systems Command in St. Louis, Missouri, and at DOD headquarters, Washington, D.C. We also visited and obtained information regarding program progress and assessment of risks from the two competing airframe contractor teams: the Bell/McDonnell team in Mesa, Arizona, and the Boeing/Sikorsky team in Philadelphia, Pennsylvania. We conducted our audit work from November 1987 through October 1988 in accordance with generally accepted government auditing standards. In order to expedite issuance of the report, we requested and received official oral comments from DOD officials. Their views are included where appropriate in subsequent chapters.

<sup>1</sup>Weapon Systems: Issues Concerning the Army's Light Helicopter Family Program (GAO/NSIAD-86-121, May 22, 1986) and Weapon Systems: Status of the Army's Light Helicopter Family Program (GAO/NSIAD-87-117FS, Mar. 13, 1987).

# More Trade-Offs Will Be Needed to Balance Technical Risks With Cost and Weight

The Army has reduced the LHX's technical requirements to meet cost and weight constraints and to lower technical risks. Balancing these competing demands has required difficult trade-offs, and further trade-offs will be necessary. For example, because of technical and operational uncertainties concerning the single-seat LHX, the Army decided in early 1987 to make the LHX a two-seat helicopter. While involving less technical risk, the second seat added weight to the LHX that has to be reduced in other areas to keep costs from increasing. Although the Army has traded off some capabilities to meet new cost and weight goals, additional trade-offs are needed. Until these decisions are made, the configuration and capabilities of the LHX will remain undecided. Regardless of what trade-offs are made, the Army will have to overcome significant hurdles in the LHX's basic technologies, and program managers face a major challenge in controlling aircraft weight.

## Weight and Cost Goals Cause Performance Trade-Offs

The June 1988 Acquisition Decision Memorandum authorizing the Army to proceed into the demonstration/validation phase directed that industry make performance, weight, and cost trade-offs to achieve a unit flyaway cost goal of \$7.5 million. The Army also added a 7,500-pound (empty weight) goal subject to the same kind of trade-offs. In the past year, the Army worked together with the contractor teams to make performance trade-offs and currently estimates the LHX to weigh approximately 8,000 pounds, with an estimated unit flyaway cost of \$8.2 million (constant fiscal year 1988 dollars). The Army has required that the contractor teams propose the remaining trade-offs to meet the cost and weight goals.

The LHX airframe and its mission equipment have changed radically from late 1987 to the present due to efforts to meet both the 7,500-pound weight goal and the \$7.5 million unit flyaway cost goal. As recently as November 1987, when the Army estimated the LHX unit flyaway cost at \$9.7 million (constant fiscal year 1988 dollars), the aircraft's empty weight was estimated at 9,800 pounds, which required a 30-percent more powerful engine, a 46-foot rotor blade, and over 1,500 pounds of mission equipment. For the current LHX version estimated at an \$8.2 million unit flyaway cost, the Army projects empty weight at 8,000 pounds. It projects that with additional trade-offs to meet cost and weight goals, the LHX will consist of the original T800 engine, a 40-foot rotor blade, and 1,290 pounds of mission equipment.

Some of the major technical changes made to lower cost and weight to date include reducing

- mission computer processing capability and changing display systems so that front and rear crew stations are no longer identical,
- the airframe's protection against ballistic weapons,
- the field-of-view requirements for the pilot's infrared night vision sensor,
- the structural durability of dynamic components such as the main rotor, and
- aircraft size because of the other weight reductions.

The weight of the basic empty helicopter was also reduced by packaging items such as blade deicing and crew foot armor in kits that can be installed in the field as necessary.

Final decisions will be made by the Army based on trade-offs proposed by the contractor teams during the demonstration/validation phase. While it is unclear how basic mission capability will be affected by these weight reductions, the aircraft may be less survivable in the battlefield environment. Also, the use of kits will have some impact because of the time and resources involved in having to reconfigure LHXS in the field with kits required for specific missions.

---

### Some Common Avionics May Be Dropped to Meet Cost and Weight Constraints

Although portions of the LHX's avionics are to be common with avionics in aircraft development programs from the other services, there are two common avionics technologies being jointly developed that the Army is not likely to include in the LHX for cost and weight reasons. The technologies in question are (1) the Integrated Communications, Navigation, Identification Avionics, which is an advanced development program to consolidate and automate the various communications, navigation, and identification radio functions now performed by a multitude of separate transmitters and receivers, and (2) the Integrated Electronic Warfare System, a program to integrate the multiple defensive electronic warfare functions of combat aircraft.

While using the two technologies intact would promote commonality among the services and could help the Army avoid some research and development cost, the Army believes that the two technology programs exceed the LHX's needs and their extra capabilities would exact weight and procurement cost penalties for the LHX. For example, the Army believes that by using discrete radios rather than the joint communications package, it can save \$400,000 per aircraft and over 100 pounds in weight. Similarly, according to the Army, the joint electronic warfare system could weigh up to 400 pounds and cost about \$6 million per unit.

Army officials believe that the LHX would not require all of the electronic warfare functions to perform its missions and that any individual functions would likely require tailoring for the LHX. The request for proposals that led to the contracts for the demonstration/validation phase includes the two joint systems as part of the LHX mission equipment package but allows the contractors to propose alternatives if they can demonstrate benefits through mission and cost-effectiveness analyses.

## Technical Hurdles Lead to Two-Seat LHX

One of the original goals of the LHX program was to design and develop a single-seat (pilot-only) helicopter, but the Army has since decided to design the LHX as a two-seat (one pilot and one copilot/gunner) helicopter. The Army abandoned the single-seat design when preliminary research and development efforts showed that available technology would not reduce the work load of the LHX's tasks to an acceptable level for one person. Eventually, the Army would like to make the LHX fully mission capable with a single pilot, but it must successfully complete development of the advanced targeting system and restore other needed avionics in the event that they are traded off in the contractors' redesign efforts.

The Army and its contractors studied the feasibility of having a single pilot fly the aircraft, identify targets, and fire weapons in the threat-intensive battle environment envisioned for the LHX. After completing these studies, the Army concluded that, while a single pilot could probably fly the LHX, the same person could not effectively perform other demanding tasks at the same time, such as target acquisition. Better mission equipment than that currently available is necessary to make the work load acceptable, particularly regarding target acquisition. A target acquisition system is needed that (1) better identifies and prioritizes targets without producing excessive false targets and (2) includes a radar that, when coupled with the optical sensor, can provide increased day, night, and adverse weather targeting capabilities.

Based on these study efforts, the Army decided in April 1987 that the LHX would be designed with a two-seat cockpit that would be single-pilot operable. Although reducing technical risk, this decision exacted higher cost and weight in the form of greater cockpit size and structure along with associated duplicate controls and displays needed for the second seat. In addition, the two-seat cockpit increased estimated operation and support costs because of the need for twice as many pilots as originally envisioned.

Although it has no current plans to do so, the Army would like to make the LHX a single-seat helicopter eventually. However, changing to a true single-pilot design would be a major development effort. Critical to such a decision will be the successful development of the advanced targeting system currently included as a planned improvement. This system will be a radar-based system that will work together with the optical targeting system to automatically identify targets without producing a high number of false targets. Even if better mission equipment adds the capabilities necessary for a single-seat LHX, the helicopter will already have been designed and optimized for two seats rather than one. Thus, a single pilot would be flying in a larger and heavier aircraft than really necessary.

Returning to a single-pilot LHX is also likely to involve restoring other technologies as well. In the Army's recent efforts to relax LHX requirements to meet cost and weight goals, some mission equipment needed for the single-pilot LHX, such as the digital map and some VHSIC computer processing capability, was dropped from the helicopter design. If these and other technologies needed for the single-seat LHX are also dropped during the contractors' design trade-offs, they will have to be restored to make the LHX a single-seat helicopter.

## Technical Risks Still Face the LHX

Although technical risks have been reduced somewhat, primarily as a result of the two-seat cockpit decision, the LHX remains a high technology program with attendant technical risks. The Army and contractors agree that the greatest risks are in the mission equipment package, particularly the sophisticated avionics architecture. The airframe itself involves risks with its composite structure and low observable design. The Army believes that these risks are manageable because of risk reduction efforts conducted over the past several years and because of the further risk reduction and demonstrations scheduled for the demonstration/validation phase.

Mission equipment risks involve the VHSIC mission computer, the electro-optical target acquisition and designation system, the wide field-of-view helmet-mounted display, and the night-vision pilotage system. Principal risk areas within these major systems involve the specific application of VHSIC technology to the individual subsystems, successful development of the advanced infrared detector critical to the improved performance of the optical target acquisition system, and development and integration of the component technologies needed to give the pilot's helmet-mounted display a wide field of view.

A major hurdle for the development and integration of all of these systems is the demanding nature of the LHX's mission requirements, coupled with the need to keep weight low. In view of these risks, the Defense Acquisition Board has directed the Army and the contractor teams to concentrate on mission equipment during the demonstration/validation phase. Program officials noted that each of the mission equipment areas is being addressed in current risk reduction efforts and will undergo preliminary demonstrations during the demonstration/validation phase.

The airframe risk areas involve the use of advanced composite materials, an advanced rotor system, and signature reduction. Although some of today's helicopter components are made from composite materials, the production of an all-composite airframe is a new step for Army helicopters. The advanced rotor will also be all composite—including the hub—and will contain no bearings. Another key feature that distinguishes the LHX from current Army helicopters is signature reduction, or "low observables," which refers to the reduction of the LHX's detectability by the enemy on the battlefield. To make the LHX less detectable, the Army will employ airframe techniques involving the shaping and use of different materials that may be augmented by radar-jamming equipment. The Army acknowledges the risks in this area but believes that engineering simulations and wind tunnel testing conducted to date have reduced airframe risk to an acceptable level.

---

## Weight Goal May Be Difficult to Achieve

Estimated aircraft weight has been difficult to control in the LHX program, and it is likely that the 7,500-pound weight goal will not be achieved. The Army needs to reduce aircraft weight by 500 pounds to meet the goal and must yet account for normal weight growth during the program, as well as the weight of planned improvements and tactical kits. While some weight growth can be accommodated without modifying the engine to produce more power, weight increases on the order of 10 percent or more are likely to necessitate engine modifications.

Difficulties in meeting the weight and cost goals are related because additional weight generally correlates to additional cost. As with cost, the Army has had considerable difficulty reducing weight while meeting LHX mission requirements, and key trade-offs will continue to be made during demonstration/validation. According to the contractor teams, weight typically grows between 5 and 10 percent from demonstration and validation in aircraft programs until fielding. This growth is due to design changes made necessary by the contractors to fix problems and to requirements changes by the government. Thus, the contractors must

set a weight target 5 to 10 percent below the 7,500-pound weight goal in order to have a realistic chance of meeting the actual goal later in the program.

In addition to the challenge of keeping the weight of the basic LHX to 7,500 pounds, the Army faces significant future weight growth from planned improvements. Specifically, the Army plans to incorporate an advanced targeting system into the LHX beginning with the fourth production lot. The Army estimates that this system will weigh between 350 to 700 pounds per helicopter and is not accounted for in the current 8,000-pound estimate.

Weight growth could adversely impact payload, range, and flight performance unless it is offset by additional requirements reductions or by modifying the helicopter to boost flight performance. According to the Army, flight performance could be improved somewhat by increasing the diameter of the main rotor, but the most significant gains could be obtained by increasing engine power. The LHX will have twin T800 engines, which are designed to produce 1,200 shaft-horsepower each—a total of 2,400 shaft-horsepower per helicopter. The T800 engine is being designed to accept modifications to increase total power up to 1,800 shaft-horsepower (3,600 per helicopter), and the additional power can be used to offset weight increases. For example, the Army had planned to use over half of this potential growth in power to accommodate the 9,800-pound LHX envisioned in late 1987.

According to the Army, if decided before the LHX design is set, the engine's power could be increased to 1,320 shaft-horsepower (2,640 per helicopter) without making any physical modifications and at relatively low cost. This increase in engine power could offset airframe weight increases of less than 10 percent. If the Army can reduce aircraft weight enough to meet the goal, it could use this power increase to offset the additional weight of the advanced targeting system. However, airframe weight increases on the order of 10 percent or more are likely to necessitate more significant engine modifications for the power needed to attain required flight performance. If the decision to increase engine power is made after the LHX design is set, modifications will be much more difficult and expensive to make because other major drivetrain components such as the transmission would require redesign to match the engine.

---

## Conclusions

The LHX's original performance requirements have proven too demanding to meet cost and weight goals and to stay within technological limits. Consequently, requirements have been relaxed somewhat, the most significant example of which is the decision to make the LHX a two-seat rather than a single-seat helicopter. Nonetheless, the LHX remains a very advanced aircraft, with significant technical risks to be overcome. At the same time, program officials face a challenge in controlling aircraft weight. Successfully developing key technology, while controlling weight, is essential to obtaining an LHX that meets requirements and is affordable.

---

## Agency Comments

DOD believes that the LHX's technical risks are manageable, noting that several government- and contractor-funded efforts over the past years have addressed the risk involved in building an LHX. According to DOD, these efforts have resulted in preliminary designs and demonstrations of high risk items such as the VHSIC mission computer, the electro-optical target acquisition system, the night vision pilotage system, and the wide field-of-view helmet-mounted display system. We recognize the risk reduction efforts that have taken place and considered them in our review of the LHX program. Nonetheless, we believe that the technical risks in the program remain substantial and represent a significant challenge, particularly in light of the LHX's cost and weight goals.

# Difficulties in Controlling Program Costs Likely to Continue

The LHX program has experienced several years of increasing cost estimates, and, in early 1988, DOD determined that the program was no longer affordable as structured. Consequently, the Army reduced the number of LHXs by half by deleting the utility version of the LHX. It also redesigned the LHX to try to meet the stringent flyaway cost goal of \$7.5 million (in constant fiscal year 1988 dollars) per helicopter set by DOD.<sup>1</sup> Estimated costs have increased steadily in the past despite the Army's previous flyaway cost goals, and the Army is having difficulty in reducing estimated costs to meet the new goal. Future cost increases are likely because of (1) uncertainty over the estimated cost of the LHX's avionics; (2) potential weight increases, which generally translate into cost increases; and (3) recent funding projections that show that planned production rates are not affordable, which will result in fewer units produced annually at an increased unit cost. Furthermore, the use of the unit flyaway cost as a cost-estimating and measurement mechanism has limitations because, by definition, LHX flyaway costs exclude about 35 percent of the helicopter's expected procurement cost.

Estimated LHX operation and support costs have increased as well, primarily due to the personnel costs associated with putting two people in the cockpit instead of one. Additional costs will occur outside of the LHX program if the Army executes its plans to buy other utility helicopters such as the Black Hawk and possibly a derivative of a commercial helicopter to make up for the loss of the LHX utility helicopter.

## Program Substantially Cut Back Following Period of Cost Increases

Until the major restructuring in 1988, the LHX program's estimated costs had increased steadily over the years, reaching a peak of \$79.7 billion (escalated dollars) in November 1987. The LHX's cost estimates and quantities are depicted in tables 3.1 and 3.2.

<sup>1</sup>Flyaway costs, a subset of procurement costs, exclude the cost of initial spares, repair parts, training support, support equipment, data, and site activation.

**Chapter 3  
Difficulties in Controlling Program Costs  
Likely to Continue**

**Table 3.1: History of the LHX Program's Cost Estimates**

Escalated dollars in millions					
<b>Cost category</b>	<b>May 1985</b>	<b>Feb. 1987</b>	<b>Apr. 1987</b>	<b>Nov. 1987</b>	<b>June 1988</b>
Research and development	\$3,200	\$4,400	\$5,000	\$5,400	\$3,900
Procurement	57,400	61,600	62,900	74,300	38,600
Unit procurement	11.4	13.7	15.1	17.3	18.4
Scout/attack unit flyaway <sup>a</sup>	6.8	7.8	9.3	9.7	8.2

<sup>a</sup>Unit flyaway costs are in constant fiscal year 1988 dollars. To compare these costs with unit procurement costs, it is necessary to convert unit procurement costs to constant fiscal year 1988 dollars. For example, the June 1988 estimate for unit procurement cost converts to \$12.7 million in constant fiscal year 1988 dollars. Comparing this with the unit flyaway cost estimate of \$2 million shows flyaway costs to be about 65 percent of procurement costs.

**Table 3.2: History of the LHX Program's Estimated Procurement Quantities**

<b>Quantities</b>	<b>May 1985</b>	<b>Feb. 1987</b>	<b>Apr. 1987</b>	<b>Nov. 1987</b>	<b>June 1988</b>
Scout/attack	3,072	2,000	2,004	2,128	2,096
Utility	1,951	2,500	2,164	2,164	0
<b>Total</b>	<b>5,023</b>	<b>4,500</b>	<b>4,168</b>	<b>4,292</b>	<b>2,096</b>

Program costs increased primarily because the Army found that the requirements developed for the LHX after the original cost projection necessitated additional mission equipment and structure. Also, while the Army had intended to make the LHX a single-seat helicopter, mission requirements proved too demanding for the available avionics technology, and the Army had to revert to a two-seat design. Adding the second seat increased the weight and cost of the LHX further. The increase in estimated research and development costs in 1987 reflects the Army's decision at that time to extend contractor competition through the test and evaluation of prototypes.

The June 1988 cost and quantity reductions reflected changes the Army made to respond to the Defense Acquisition Board's conclusion that the LHX was "no longer a viable program for affordability reasons." The Deputy Secretary of Defense directed the Army to refocus the LHX program to develop a lightweight, low-cost helicopter that would become an integral part of an affordable Army aviation modernization plan. As a result, the Army significantly scaled the program back, most notably by deleting the utility version and consequently reducing quantities from 4,292 to 2,096.

## Major Program Changes Made to Reduce Costs

The Army made significant changes to the LHX program to lower estimated costs in accordance with DOD's direction. Table 3.3, which illustrates these changes, compares the November 1987 program with the revised June 1988 program.

**Table 3.3: Changes Made to the LHX Program**

November 1987	June 1988
Total program cost of \$79.7 billion (escalated dollars)	Total program cost of \$42.5 billion (escalated dollars)
Scout/attack unit flyaway costs of \$9.7 million (constant 1988 dollars)	Scout/attack unit flyaway costs of \$8.2 million (constant 1988 dollars)
4,292 helicopters: 2,128 scout/attack and 2,164 utility	2,096 helicopters: all scout/attack; utility deleted
Scout/attack weight of 9,800 pounds	Scout/attack weight of 8,000 pounds
Competition through 5-year demonstration/validation phase—with flying prototypes	Competition through 2-year demonstration/validation phase—no prototypes

To meet the new flyaway unit cost goal of \$7.5 million set by DOD, the Army conducted several rounds of requirements reevaluations to reduce estimated costs and weight for both mission equipment and the airframe. Through these exercises, the Army lowered the estimated unit flyaway cost to about \$8.2 million and the empty weight to about 8,000 pounds. The Army has required the contractor teams to propose the remaining trade-offs needed to reach the cost and weight goals. Total production costs decreased because of (1) the reduction in quantity due to the removal of the utility version of the LHX and (2) the reduction in requirements and equipment for the smaller (7,500-pound) LHX. The unit cost reductions in the scout/attack version were offset somewhat by the lower number of total helicopters over which to spread fixed costs. The deletion of the utility version also allowed planned production rates to be reduced from 480 to 216 helicopters per year.

## Program Costs Are Likely to Increase

Although DOD has taken a difficult step in substantially reducing the LHX program, costs are likely to continue to increase. The Army is having difficulty meeting the new unit flyaway cost goal, and costs may increase due to uncertainties regarding estimated costs for the LHX's avionics and to the potential for weight growth. In addition, according to recent DOD funding projections through the year 2006, there is not enough procurement money available to produce the LHX at planned rates. The reduced production rates will extend the program schedule and will result in cost increases.

---

### Office of the Secretary of Defense Has Identified Areas of Potential Increases

The Office of the Secretary of Defense's Cost Analysis Improvement Group, based on its review of the Army's LHX cost estimate, reported that the Army's flyaway cost estimate is low and that it is unlikely that the Army will attain its \$7.5 million unit cost goal. The cost analysis group believes that uncertainty over the cost of avionics, as well as potential aircraft weight growth, will drive up flyaway costs. Army officials noted that they have had considerable difficulty trading off performance requirements and weight to meet the goal, and they currently estimate the unit flyaway cost at \$8.2 million (constant fiscal year 1988 dollars). However, the Army and the contractor teams expressed commitment to the \$7.5 million unit cost goal and believe that, while challenging, the goal is achievable. According to the Army, the demonstration/validation program will lead to specific designs that will be at or below the goals. The contractors also have plans for design-to-cost efforts to hold to the goal.

---

### Funding Projections Show Planned Production Rates to Be Unaffordable

Although planned LHX production rates were reduced to a peak of 216 per year in the June 1988 restructuring, a DOD projection of available funds since then shows that LHX production will peak at 157. The reduced production rate will stretch the LHX program out over a greater number of years and will cause increased unit costs. Similarly, production of the Black Hawk utility helicopter will be reduced from 72 per month to 60 per month over the same time period.

In 1988, the Army doubled the total number of Black Hawks to be produced—from 1,111 to 2,253 helicopters. About 500 of the additional Black Hawks were added to make up for the deletion of the LHX utility version. According to the Army, another 1,100 utility helicopters will be needed to fully compensate for the cancellation of the LHX utility. These additional utility helicopters could be made up of more Black Hawks, a derivative of a commercial helicopter, and/or a major modification of the UH-1 helicopter.

The production rates for the Black Hawk and the LHX—the only helicopters currently slated for production beyond 1995—are shown in table 3.4.

**Table 3.4: Production Rates for Army Helicopters Based on Projected Funding**

Helicopter	Production rate by fiscal year											
	1995	1996	1997	1998	1999	2000	2001	2002	2003	2004	2005	2006
LHX	20	34	53	68	77	88	103	112	117	126	153	157
Black Hawk	60	60	60	60	60	60	60	60	60	60	60	60

According to the Army, reductions in the LHX's peak production rates and the buildup to those rates were necessary because the new funding projection for future aviation procurement is lower than what was anticipated when the Army prepared its Aviation Modernization Plan in May 1988. The LHX program office estimates that the lower production rates and resulting stretch-out will increase costs by 10 percent and that the available funding is not sufficient to acquire the advanced targeting system.

The LHX's affordability will also be affected by increased competition for limited funds by other programs. For example, the current funding projection does not provide funds for the 1,100 additional utility helicopters the Army believes it needs to fully compensate for the cancellation of the LHX utility version or for the advanced targeting system. If the Army decides it must fund these two efforts, they will become another competing demand for the same source of funds as the LHX.

### Flyaway Costs May Not Be Meaningful as a Cost-Measurement and Control Mechanism

Although LHX cost goals have historically been expressed in terms of unit flyaway costs, recent program changes have brought to light the drawbacks of using such costs as a cost-estimating and measurement mechanism. Flyaway costs, which are a subset of procurement costs, exclude initial spares, support equipment, and items procured on less than a one-for-one basis with the aircraft. The Army considers these latter items as "kits" to be added in the field as the need arises. Similarly, a significant planned improvement—an advanced targeting system—is included in the procurement cost estimate but is excluded from flyaway costs. Thus, flyaway costs do not reflect the full cost of an LHX equipped for its primary mission—armed reconnaissance in a high-threat environment—which would likely include several kits and the advanced targeting sensor.

LHX kits include such items as infrared jammers, radio frequency jammers, blade deicing units, and crew foot armor. The Army believes that, since these kits will only be needed for certain specialized missions, the

helicopter can be designed so that these items can be simply added in the field when required. The Army plans to produce several kits in quantities of 1,990 apiece—enough for about 95 percent of the 2,096 LHXS.

The improved targeting system, referred to as the Airborne Adverse Weather Weapon System, consists of an advanced fire control radar system to be installed above the rotor mast and a radio frequency seeker for the Hellfire missile. It is intended to significantly enhance fighting capability in adverse weather and provide a true fire-and-forget capability, thus increasing battlefield effectiveness and survivability. The Army has excluded the targeting system from flyaway costs because the system is being procured for only 700 of the 2,096 helicopters and because it believes that the system is too early in development for meaningful cost estimates to be made. The Army would like to add the advanced system to all LHXS but believes that it cannot afford to do so.

According to a preliminary LHX program office estimate, the kits, taken together, would cost \$0.35 million for each set, and the advanced targeting system could cost up to \$1.25 million per unit. Thus, for an individual LHX equipped with all the tactical mission kits plus the target sensor, the unit flyaway cost would be nearly \$1.6 million higher than the current estimate of \$8.2 million. Averaging the total cost of all the kits and the advanced targeting system for all 2,096 helicopters would add about \$0.7 million to the \$8.2 million unit flyaway cost estimate.

Because flyaway costs exclude a number of procurement items, they may not accurately reflect changes in cost estimates. For example, if the cost of spare parts or a particular kit increased, the increase would not show up in the flyaway cost estimate. Also, if the Army decided to delete an item from the LHX's basic equipment and supply it in a kit, flyaway costs would indicate a cost decrease when a true decrease did not occur. Other measurements of cost are available that are more complete than flyaway costs and can more accurately reflect changes in estimated costs. One such measurement is unit procurement cost, which averages total LHX procurement costs over the total number of helicopters to be procured. Another possible measurement is the estimated procurement cost of an LHX equipped for its primary mission—which would exclude the cost of items needed for other missions.

---

## Erosion of Savings Goals for Operation and Support Costs

Early in the LHX program, the Army established as a major program goal that the operation and support costs of the LHX be 40 to 50 percent lower than those of the fleet it was replacing. Due primarily to the change from one to two pilots and the associated increases in personnel costs, expected savings in operation and support costs over the current fleet have almost evaporated. Army officials now estimate a 15- to 20-percent savings over the current fleet. The savings result primarily from the Army's plans to replace older helicopters with a smaller number of LHXs. Army officials note that the LHX is considerably more capable than the aircraft it replaces, and according to one of the contractor teams, the LHX provides significantly greater war-fighting capability for the same operation and support costs.

Because of difficulties in estimating and comparing operation and support costs for both the LHX and the current fleet, as well as erosion in the estimated savings, the Army has abandoned its original goal and has de-emphasized such goals in its demonstration/validation program. The Army still plans, however, to require contractors to commit themselves to contractual guarantees of operational and support costs during later program phases.

---

## Conclusions and Recommendation

The difficulty the Army has had with controlling LHX unit costs in the past is likely to continue. More trade-offs are needed to meet the revised unit flyaway cost goal, and potential for cost growth already exists in the form of technical risks, weight growth, and reduced production rates. The LHX's affordability is sensitive to program cost, and therefore future cost growth is likely to result in additional production rate reductions and schedule delays.

Flyaway costs may not provide a sound basis for controlling and measuring LHX costs because they cover only about 65 percent of expected procurement costs and exclude some items important to performing LHX missions. A more inclusive measure of cost may be necessary to provide needed oversight to all key elements of cost and a better indicator of expected procurement costs.

We recommend that the Secretary of Defense set program cost goals around more meaningful cost measurements than flyaway costs, such as the cost of an LHX equipped for its primary mission, the unit procurement cost, or both.

---

**Agency Comments**

DOD officials agreed that for Army and DOD management purposes, more inclusive measurements, such as unit procurement costs, should be used to set program goals and to gauge the program's progress against the goals. However, they stated that flyaway costs should be retained as a yardstick for the contractors since these are the costs over which contractors have the most control.

# Acquisition Strategy Reduces Competition and Provides Less Information for a Full-Scale Development Decision

The Army has made a considerable number of changes to the LHX acquisition strategy to reduce development costs. The current strategy calls for a shortened demonstration/validation phase that eliminates building and evaluating competitive prototypes before the Army selects a winning contractor team and begins full-scale development. Such a strategy will provide the Congress and DOD with less information and a much less mature weapon system on which to base these key development decisions.

Law, DOD regulations, independent Defense studies, and Army practices in other major weapon programs support a competitive prototype acquisition strategy as the preferred approach. Such a strategy would provide greater resolution of risks, demonstration of capabilities, and confirmation of cost estimates in preparation for key decisions. DOD and LHX program officials agree that a more thorough competitive acquisition strategy would be preferable but believe that there are insufficient research and development funds to cover the additional cost of that approach. They believe that the shortened demonstration and validation phase will provide good designs from which the Army can select a winning contractor team to enter full-scale development.

## Demonstration/ Validation Phase Shortened to Save Money

To comply with DOD guidance to reduce the total research and development funding requirements for the LHX program, the Army reduced the competitive demonstration/validation phase from about 5 years to about 2 years. The reduction in scope reduced estimated LHX research and development costs from \$5.4 billion to \$3.9 billion (escalated dollars). The shortened demonstration and validation phase will include the following activities:

- Definition of performance requirements for the LHX through design, analysis, and selected demonstrations (including air-to-air simulations, wind tunnel work, preliminary design efforts, and cockpit mock-ups). The purpose is to further trade off performance requirements to meet weight and cost goals.
- Definition of the mission equipment package and avionics architecture based on performance requirements.
- Demonstration of the performance of key mission equipment package components with test hardware.

**Chapter 4**  
**Acquisition Strategy Reduces Competition**  
**and Provides Less Information for a Full-**  
**Scale Development Decision**

The demonstration/validation phase of the previous LHX acquisition strategy was much greater in scope, providing for a much more extensive demonstration of key technologies under competition with a consequently less extensive full-scale development phase. Figure 4.1 compares the two strategies.

**Figure 4.1: Comparison of June 1987 and June 1988 Acquisition Strategies**

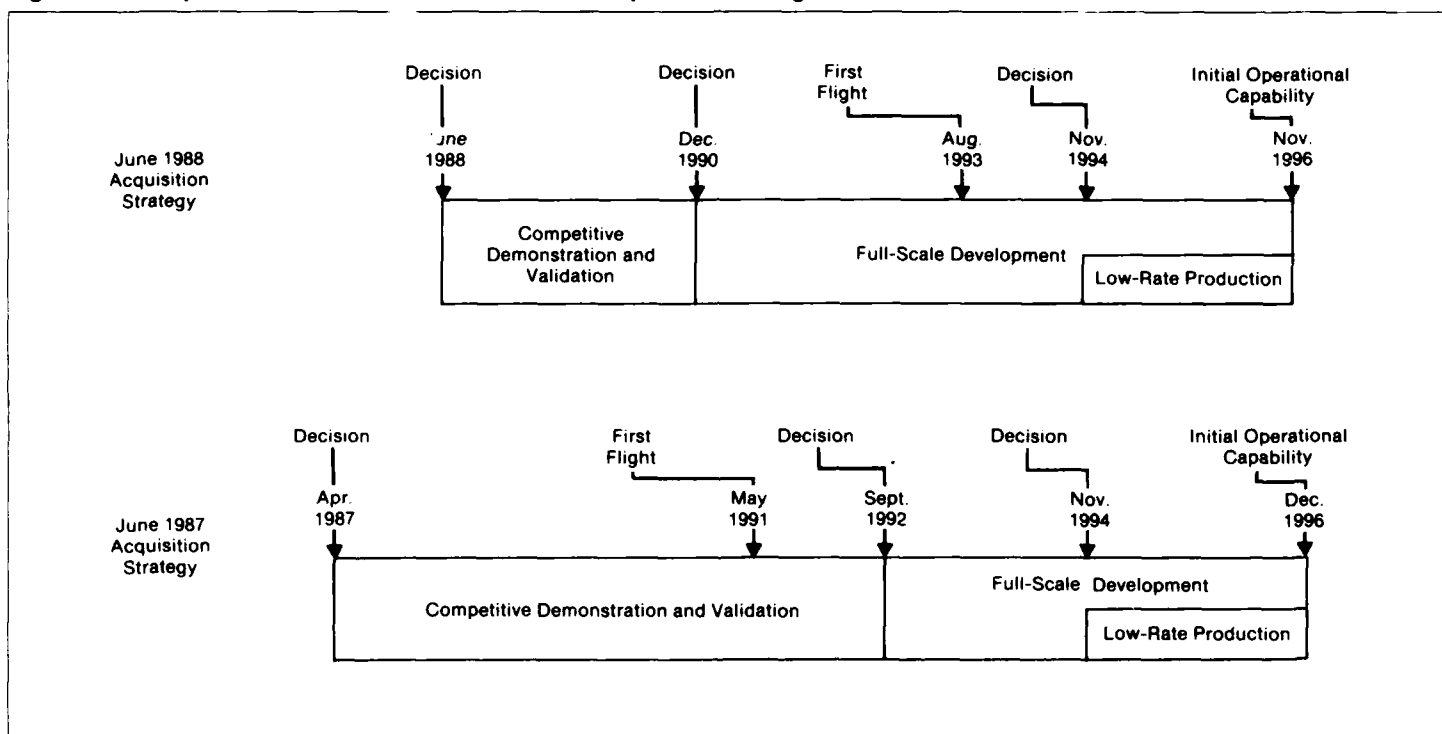

The current strategy is to cover more than 8 years, split between over 2 years of demonstration/validation and 6 years of full-scale development, while the June 1987 strategy was to cover more than 9 years, split between over 5 years of demonstration/validation and about 4 years of full-scale development. The main difference between the two strategies is that the June 1987 strategy carried competition through prototype test and evaluation before selecting a winning team and entering full-scale development. The current strategy no longer includes the competitive testing of LHX mission equipment aboard prototype LHX helicopters before contractor selection and full-scale development. The additional cost of the previous acquisition strategy is due primarily to the cost of

funding the second contractor team through prototype test and evaluation.

Under the current acquisition strategy, the demonstration/validation phase will be essentially a paper design competition with some preliminary mission equipment demonstrations. Test and evaluation of mission equipment aboard prototype LHXs will be postponed until full-scale development, which accounts for that phase's increased length. Thus, DOD and the Congress will not have the benefit of the demonstrated flight performance and validated cost estimates of either mission equipment or the airframe on which to base a contractor selection or the decision to commit the program to full-scale development.

## Current Acquisition Strategy Runs Counter to Defense Policies and Practices

The current LHX acquisition strategy reflects a decision to reduce research and development costs and to accept the higher risk approach of a shorter competitive phase and an earlier commitment to full-scale development. Although DOD policies allow acquisition strategies to be tailored to the specific needs of a system, the LHX acquisition strategy runs counter to DOD and congressional policies in general, as well as to specific guidance by the Defense Science Board and to the Army's own acquisition practices. Officials from DOD and the LHX program manager's office agreed that the previous strategy of prototype competition through the demonstration/validation phase is preferable but that its cost—\$5.4 billion versus the \$3.9 billion for the current strategy—exceeded the dollars projected to be available.

DOD regulations encourage prototyping during the concept exploration phase or demonstration/validation phase. DOD defines a prototype as "an original or model on which a later item is formed or based, which is usually built during demonstration/validation and tested prior to the Milestone II decision." DOD regulations call for adequate test and evaluation to establish realistic performance thresholds and to reduce risk and uncertainty before more resources are committed to full-scale development. Similarly, in 1986, the President's Blue Ribbon Commission on Defense Management recommended that a high priority be given to building and testing prototypes before proceeding into full-scale development. The Commission stated that such prototyping should demonstrate that the new technology can substantially improve military capability and should provide a basis for making realistic cost estimates.

According to 10 U.S.C. 2365 (Supp. IV 1986), competitive prototyping is required in the development of major weapon systems entering

advanced development after September 30, 1986. However, the act does allow for exceptions where the Secretary of Defense can show in writing that such a strategy is not practicable for a particular program. LHX program officials stated that they intended to request such an exception for the LHX.

The Army has in fact typically conducted competitive test and evaluation of prototypes before committing major weapon programs to full-scale development. The Army employed such a strategy in the M1 tank, Apache attack helicopter, Hellfire missile, and Copperhead projectile programs. In programs that did not proceed through discrete demonstration/validation and full-scale development phases, such as the Black Hawk helicopter and Multiple Launch Rocket System programs, the Army carried competition through the test and evaluation of prototypes before selecting a winning contractor.

In 1986, the Defense Science Board conducted a specific review of the LHX program and recommended that the Army include prototype competition before selecting a winning contractor team. The Board noted that competitive prototyping was the only approach by which the Army could both provide an adequate incentive to contractors to try to optimize trade-off possibilities and assure itself through actual data that its cost estimates for the program were realistic and that its performance goals were valid. The Board also concluded that prototyping at least the higher risk parts of the design could have profound positive effects in disciplining the design specifications, maintaining competition, and discovering difficulties early in the process when they are less expensive to fix.

---

### Alternative Acquisition Strategies Are Available

Alternative acquisition strategies for the LHX are available that would be less costly than the previous strategy that called for test and evaluation of competitive prototype helicopters with prototype mission equipment aboard and yet would provide better information to decisionmakers than the current strategy. According to the LHX program office, one alternative would involve a 38-month demonstration/validation phase that would include full competitive demonstrations of the mission equipment package—the riskiest part of the LHX's development—aboard surrogate aircraft rather than prototype LHXs. According to program officials, this approach would cost about \$4.9 billion—a half billion less than the previous strategy. The officials stated that the \$4.9 billion approach, while less costly, would still be unaffordable and could require additional time.

Another alternative would be to modify the current strategy by separating the contractor team selection from the full-scale development decision. The Army could then select the winning team as scheduled and could postpone the full-scale development decision at least until the winning contractor's prototype mission equipment is tested and evaluated. This approach would enable a more informed full-scale development decision without necessarily increasing cost or delaying the schedule. However, it does not conform to the guidance that prototypes should be competitively tested and evaluated if practicable.

---

### Acquisition Strategy May Also Be Modified to Eliminate Dual Sourcing

As directed by DOD, the Army is also considering whether to break up the winning contractor team for dual sourcing or to allow the team to stay together and coproduce. Since the beginning of the program, the Army has planned to break up the winning contractor team after the third production year to allow for dual sourcing. The winning contractor would be awarded the larger share of the production contract. Allowing the team to remain intact eliminates this strategy. According to the contractor teams, coproduction could save the Army money by reducing duplicate tooling and production line costs. They also pointed out that recent decisions that have cut the program in half substantially reduce the long-term savings potential from dual sourcing. The Army plans to issue a study contract during the demonstration/validation phase to assess the effects of such a change.

---

### Compatibility With Engine Development

The T800 engine, currently in full-scale development, has been designated for LHX use. The engine program was started prior to the LHX airframe program in order to allow engine development problems to be resolved before airframe development was completed. However, because of numerous delays in airframe development, engine development is now far ahead of airframe development. This incompatibility in schedule, along with funding shortages, has caused the Army to restructure existing engine contracts and extend development for about 2 years to accommodate the lagging airframe program.

The Army recently selected the winning engine contractor team and awarded the follow-on contract to complete the development phase and enter production. The competitive source selection process included the proposed reductions to the existing contracts to accommodate funding constraints, an additional period to support airframe development, and engine production. Army officials emphasize that because these contract changes were negotiated in a competitive environment before selecting

the winning contractor team, the changes should not have dire cost consequences to the program.

---

## Conclusions and Recommendations

In attempting to reduce development costs, the Army has chosen a higher risk acquisition strategy that may not provide decisionmakers with critical information—such as demonstrated performance and validation of cost estimates—when needed for key decisions. This information is pivotal for the LHX program, given the advanced technology involved and the demonstrated impact of cost growth on the program's affordability. DOD has decided that, while a more conservative acquisition strategy is desirable, it is not affordable. However, the fact that there are insufficient research and development funds to pursue a better approach to developing a weapon system of such significance to the Army may mean that DOD should reassess the priorities of its research and development projects.

We recommend that the Secretary of Defense take the following actions:

- Reassess whether the LHX warrants a higher priority for more research and development funds within projected resources to pursue an acquisition strategy that provides for the test and evaluation of competitive prototypes, particularly regarding mission equipment, before selecting a winning contractor team and committing the program to full-scale development.
- If the current acquisition strategy is pursued, separate the decision to select the winning contractor from the decision to commit the program to full-scale development by postponing the full-scale development decision until it can be made on the basis of the winning contractor's demonstrated performance with prototypes.

---

## Agency Comments

DOD officials agreed that a competitive prototyping strategy would be preferable for the LHX but noted that, while the LHX's priority among research and development efforts has been and will continue to be under reassessment, at this time DOD cannot afford such a strategy. They believe that the limited mission equipment demonstrations planned under the current strategy, as well as engineering simulations, design trade-offs, and wind tunnel tests, will provide an adequate basis for the decision to enter full-scale development. DOD officials stated that if, at the time of the full-scale development decision, available information is insufficient or if technical risks are deemed too high to select a winning

---

**Chapter 4  
Acquisition Strategy Reduces Competition  
and Provides Less Information for a Full-  
Scale Development Decision**

---

contractor or to proceed into full-scale development, they will extend the demonstration/validation phase.

---

# Major Contributors to This Report

---

**National Security and  
International Affairs  
Division, Washington,  
D.C.**

Richard Davis, Senior Associate Director, (202) 275-4141  
F. James Shafer, Group Director  
Paul Francis, Technical Advisor

---

**Kansas City Regional  
Office**

James S. Moores, Regional Management Representative  
Gregory Symons, Evaluator-in-Charge