

ATTN: FILE COPY

4

TECHNICAL REPORT BRL-TR-2959

BRL

1938 - Serving the Army for Fifty Years - 1988

AD-A203 297

INSTRUCTIONS FOR USE OF NON-DISCRETE
AND QUASISTATIC DIAPHRAGM PRESSURE GAGES

HENRY J. GOODMAN
EDWARD J. HORWATH

DECEMBER 1988

DTIC
ELECTE
S E D

APPROVED FOR PUBLIC RELEASE; DISTRIBUTION UNLIMITED.

U.S. ARMY LABORATORY COMMAND

**BALLISTIC RESEARCH LABORATORY
ABERDEEN PROVING GROUND, MARYLAND**

89 1 30 053

DESTRUCTION NOTICE

Destroy this report when it is no longer needed. DO NOT return it to the originator.

Additional copies of this report may be obtained from the National Technical Information Service, U.S. Department of Commerce, Springfield, VA 22161.

The findings of this report are not to be construed as an official Department of the Army position, unless so designated by other authorized documents.

The use of trade names or manufacturers' names in this report does not constitute indorsement of any commercial product.

REPORT DOCUMENTATION PAGE

Form Approved
OMB No. 0704-0188

1a. REPORT SECURITY CLASSIFICATION Unclassified		1b. RESTRICTIVE MARKINGS None		
2a. SECURITY CLASSIFICATION AUTHORITY		3. DISTRIBUTION / AVAILABILITY OF REPORT APPROVED FOR PUBLIC RELEASE; DISTRIBUTION UNLIMITED		
2b. DECLASSIFICATION / DOWNGRADING SCHEDULE				
4. PERFORMING ORGANIZATION REPORT NUMBER(S) BRL-TR-2959		5. MONITORING ORGANIZATION REPORT NUMBER(S)		
6a. NAME OF PERFORMING ORGANIZATION US Army Ballistic Research Laboratory	6b. OFFICE SYMBOL (if applicable) SLCBR-TB-A	7a. NAME OF MONITORING ORGANIZATION		
6c. ADDRESS (City, State, and ZIP Code) Aberdeen Proving Ground, MD 21005-5066		7b. ADDRESS (City, State, and ZIP Code)		
8a. NAME OF FUNDING / SPONSORING ORGANIZATION	8b. OFFICE SYMBOL (if applicable)	9. PROCUREMENT INSTRUMENT IDENTIFICATION NUMBER		
8c. ADDRESS (City, State, and ZIP Code)		10. SOURCE OF FUNDING NUMBERS		
		PROGRAM ELEMENT NO.	PROJECT NO.	TASK NO.
11. TITLE (Include Security Classification) Instructions for Use of Non Discrete and Quasistatic Diaphragm Pressure Gages				
12. PERSONAL AUTHOR(S) Henry J. Goodman, Henry J. Horwath, Edward J. [Signature]				
13a. TYPE OF REPORT	13b. TIME COVERED FROM _____ TO _____	14. DATE OF REPORT (Year, Month, Day)	15. PAGE COUNT	
16. SUPPLEMENTARY NOTATION				
17. COSATI CODES		18. SUBJECT TERMS (Continue on reverse if necessary and identify by block number) Blast Pressure, Pressure Gages . JES [Signature]		
FIELD	GROUP			SUB-GROUP
04				
02				
19. ABSTRACT (Continue on reverse if necessary and identify by block number) This report presents Instructions for Use of both Non-Discrete and Diaphragm Pressure Gages for blast overpressure measurement. Figures are presented from which peak blast pressure may be calculated based on deformation or rupture of thin aluminum foils. → 6 179				
20. DISTRIBUTION / AVAILABILITY OF ABSTRACT <input type="checkbox"/> UNCLASSIFIED/DN LIMITED <input checked="" type="checkbox"/> SAME AS RPT <input type="checkbox"/> DTIC USERS		21. ABSTRACT SECURITY CLASSIFICATION		
22a. NAME OF RESPONSIBLE INDIVIDUAL		22b. TELEPHONE (Include Area Code)	22c. OFFICE SYMBOL	

TABLE OF CONTENTS

LIST OF FIGURES	v
LIST OF TABLES	vi

Paragraph		
1.0	INTRODUCTION	1
2.0	OPERATING INSTRUCTIONS: NON-DISCRETE PRESSURE GAGE (NDDPG)	1
2.1	Selection of Foil	1
2.2	Installation of Foil	1
2.3	Attachment of Gage Housing to Gage Mount.	1
2.4	Protecting Foil	2
2.5	Gage Orientation for Blast Experiment in/on a Compartment	2
2.5.1	Small Charge Detonated Inside Compartment	2
2.5.2	Explosive or Shaped Charge Detonated or Impacting Outside Compartment	2
2.5.3	Omnidirectional Gage Placement	2
2.6	Gage Orientation for Blast Experiment, in Open Area	2
2.7	Auxiliary Equipment	3
2.8	Deformation Measurement	3
2.9	Rupture Measurement	3
2.10	Peak Overpressure Values	3
2.11	Calibration Curves	3
2.11.1	Calibration Curve "A"	3
2.11.2	Calibration Curve "B1"	3

TABLE OF CONTENTS (Cont.)

2.11.3 Calibration Curve "B2" 3

2.11.4 Calibration Curve "B3" 4

2.11.5 Calibration Curve "C1" 4

2.11.6 Calibration Curve "C2" 4

2.11.7 Calibration Curve "C3" 4

2.11.8 Calibration Curve "D" 4

2.11.9 Calibration Curve "E" 4

3.0 OPERATING INSTRUCTIONS: QUASI-STATIC
DIAPHRAGM PRESSURE GAGE (QSDPG) . . 16

3.1 Selection of Foil 16

3.2 Installation of Foil. 16

3.3 Attachment of Gage Housing to
Gage Mount 16

3.4 Gage Orientation for Blast Experiment
in a Compartment 16

3.4.1 Small Charge Detonated Inside
Compartment 16

3.4.2 Explosive or Shaped Charge
Detonated or Impacting Outside
Compartment 17

3.5 Auxiliary Equipment 17

3.6 Deformation Measurement 17

3.7 Peak Quasi-Static Overpressure Values . . 17

Accession For		<input checked="" type="checkbox"/>	<input type="checkbox"/>	<input type="checkbox"/>
NTIS GRA&I				
DTIC TAB				
Unannounced				
Justification				
By				
Distribution/				
Availability Codes				
Dist	Avail and/or Special			
		A-1		

LIST OF FIGURES

- Figure 1. Construction plan with end view of the non-discrete diaphragm pressure gage (NDDPG) 6
- Figure 2. Diagram showing placement of foil in the non-discrete diaphragm pressure gage (NDDPG) 6
- Figure 3. Correlation curve "A": Face-on overpressure (PSI) correlated with side-on overpressure (PSI) 7
- Figure 4. Correlation curve "B1": Side-on overpressure (PSI) correlated with deformation or rupture (inch/scale), using .0005-in. foil 8
- Figure 5. Correlation curve "B2": Side-on overpressure (PSI) correlated with rupture only (scale), using .0005-in. foil 9
- Figure 6. Correlation curve "B3": Side-on overpressure (PSI) correlated with deformation only (inch), using .0005-in. foil 10
- Figure 7. Correlation curve "C1": Side-on overpressure (PSI) correlated with deformation or rupture (inch/scale), using .001-in. foil 11
- Figure 8. Correlation curve "C2": Side-on overpressure (PSI) correlated with rupture only (scale), using .001-in. foil . . . 12
- Figure 9. Correlation curve "C3": Side-on overpressure (PSI) correlated with deformation only (inch), using .001-in. foil 13
- Figure 10. Correlation curve "D": Side-on overpressure (PSI) correlated with deformation (inch), using .003-in. foil. Curves are plotted for both side-on and face-on configuration of foil plane 14

LIST OF FIGURES (Cont.)

- Figure 11. Correlation curve "E": Side-on overpressure (PSI) correlated with deformation (inch), using .005-in. foil. Curves are plotted for both side-on and face-on configuration of foil plane 15
- Figure 12. Construction plan with end view of the quasi-static diaphragm pressure gage (QSDPG) 18
- Figure 13. Diagram showing placement of foil in the quasi-static diaphragm pressure gage (QSDPG) 18
- Figure 14. Correlation curves for .001-in., .003-in., and .005-in. foil: Overpressure (PSI) correlated with deformation (inch) for quasi-static overpressure measures . 19

LIST OF TABLES

- Table 1. Summary of calibration curve derivation and use 5

1.0 INTRODUCTION

The Ballistics Research Laboratory (BRL) at Aberdeen Proving Ground (APG) has developed two diaphragm pressure gages for use in measuring shock and quasi-static overpressure during severe test conditions. Plans for the construction of a Non-Discrete Diaphragm Pressure Gage (NDDPG) from 1/8-in. and 3/4-in. mild steel and calibrated aluminum foil are presented (Figures 1 and 2), along with calibration curves developed for use with a range of expected shock overpressure values and foil thicknesses (Figures 3-11). Plans for the construction of a Quasi-Static Diaphragm Pressure Gage (QSDPG) from 1/8-in. and 3/4-in. mild steel and calibrated aluminum foil are presented (Figures 12 and 13), along with calibration curves developed for use with a range of expected quasi-static overpressure values and foil thicknesses (Figure 14).

2.0 OPERATING INSTRUCTIONS NON-DISCRETE PRESSURE GAGE (NDDPG)

2.1 Selection of Foil. An estimate of expected maximum shock overpressure determines the appropriate foil thickness. Using previous experimental data, estimate an expected maximum overpressure. Select a calibration curve (Figures 3-11) that incorporates an overpressure range approximately 10 to 25 percent greater than the estimate. Install, in the NDDPG, the foil correlated with the chosen calibration curve. Please note that any new foil must be pure, annealed aluminum and must be calibrated before using (1).

2.2 Installation of Foil. The appropriate thickness of foil is sandwiched between the pressure gage calibration plate and resonating chamber (see Figure 1, end view, and Figure 2 for details). The calibration plate also serves as a cover plate for the pressure gage. Remove the cover plate, placing the desired thickness of foil over the chamber. Using a sharp instrument, such as an awl or an ice pick, punch holes in the foil to align with the screw holes in the cover plate. Replace the screws, taking care to keep the foil intact.

2.3 Attachment of Gage Housing to Gage Mount. The gage is mounted on a paddle-type gage mount for experimental use. Insert the screws completely through the gage housing and back cover plate before attaching it to the mount. Verify that the chamber behind the foil is covered by either the back plate or the gage mount paddle. The back plate may be omitted when a solid-paddle gage mount is used.

(1) A source is: International Foils
2081 McCrea Street
Alliance, Ohio 44601
(216) 823-1700

2.4 Protecting Foil. To protect the installed foil leaf from perforation or soil, place a stiff cardboard square over the foil and attach it with rubber bands.

2.5 Gage Orientation for Blast Experiment in/on a Compartment. The NDDPG can be oriented for compartmented detonation, explosive or shaped charge detonation, and omnidirectional blast pressure measurement.

2.5.1 Small Charge Detonated Inside Compartment. The NDDPG permits either face-on or side-on orientation of the foil with respect to shock propagation inside a test compartment. For face-on orientation, place the gage inside the compartment with the normal-to-foil surface pointing in the direction of the charge center or with the foil-normal plane parallel to the direction of propagation of the initial shock of the blast. For side-on orientation, place the gage inside the compartment with the plane of the foil surface passing through the charge center or with the foil plane parallel to the direction of propagation of the initial shock.

2.5.2 Explosive or Shaped Charge Detonated or Impacting Outside Compartment. The NDDPG permits either face-on or side-on orientation of the foil with respect to shock propagation outside a test compartment at one of its walls. For face-on orientation, prepare a hole through the wall to be affected by the explosive or shaped charge. Place the gage inside the compartment with the normal-to-foil surface pointing in the direction of the entrance of the hole. Alternatively, place the gage inside the compartment with the normal-to-foil surface parallel to the direction of propagation of the initial shock. For side-on orientation, place the gage inside the compartment with the plane of the foil surface parallel to the direction of propagation of initial shock.

2.5.3 Omnidirectional Gage Placement. The NDDPG permits omnidirectional measurement of peak blast or shock overpressure using side-on calibration curves. Place the gage in the compartment wall with the foil surface parallel to and flush with the interior surface of the compartment. The initial shock wave travels across the foil surface like an oblique wave or mach stem.

2.6 Gage Orientation for Blast Experiment in Open Area. The NDDPG can be oriented to measure the detonation pressure of an explosive charge in an open area. For face-on orientation, place the gage with the normal-to-foil surface pointing in the direction of the charge center or with the foil-normal plane parallel to the direction of propagation of the initial shock. For side-on orientation, place the gage with the plane of the foil surface passing through the charge center. Alternatively, place the gage with the foil plane parallel to the direction of propagation of the initial shock.

2.7 Auxiliary Equipment. Measuring peak blast or shock overpressure requires the use of a depth-gage micrometer and a recording form.

2.8 Deformation Measurement. Measuring peak blast or shock overpressure is a three-step process. First, place the micrometer on the scale surface of the gage housing, positioning it at the point of maximum deformation depth or maximum opening. If the foil is not concave at the point of maximum depth or maximum opening, push the foil down to a configuration where permanent deformation is not altered. Second, measure the depth (D) from the scale surface. Finally, subtract the cover plate thickness (T) from measured depth (D) to obtain permanent deformation depth (PD). Please note that no quasi-static pressure can be determined if the foil ruptures. Therefore, a pressure range should be determined that eliminates the potential for rupture.

2.9 Rupture Measurement. Measuring peak blast or shock overpressure when the NDDPG foil has ruptured makes use of the scale increments on its cover plate (Figure 1). Count the number of scale markings from the point of maximum opening (i.e., the initial scale mark) to the end of the rupture, moving in the direction of the cone vertex.

2.10 Peak Overpressure Values. Determining peak overpressure value for a given blast requires the use of an appropriate calibration curve. Choose the curve (A, B1, B2, B3, C1, C2, C3, D, or E) corresponding to the thickness of the foil used and the orientation of the foil (face-on or side-on) to the propagating wave. See Table 1 for a summary of calibration curve parameters.

2.11 Calibration Curves.

2.11.1 Calibration Curve "A." Choose calibration curve "A" to determine face-on overpressure from observed side-on overpressure. It correlates face-on with side-on overpressure (Figure 3).

2.11.2 Calibration Curve "B1." Choose calibration curve "B1" to determine side-on overpressure for determination or rupture with .0005-in. foil. It correlates side-on overpressure with deformation (or rupture) for .0005-in. foil, with the plane of the foil oriented normal to the direction of propagation of the initial shock (Figure 4).

2.11.3 Calibration Curve "B2." Choose calibration curve "B2" to determine side-on overpressure with .0005-in. foil when rupture occurs. This curve correlates side-on overpressure with rupture for .0005-in. foil, the plane of the foil oriented normal to the direction of propagation of the initial shock (Figure 5).

2.11.4 Calibration Curve "B3." Choose calibration curve "B3" to determine side-on overpressure with .0005-in. foil when only deformation occurs. This curve correlates side-on overpressure with deformation for .0005-in. foil, with the plane of the foil oriented normal to the direction of propagation of the initial shock (Figure 6).

2.11.5 Calibration Curve "C1." Choose calibration curve "C1" to determine side-on overpressure for deformation of rupture with .001-in. foil. This curve correlates side-on overpressure with deformation or rupture for .001-in. foil, with the plane of the foil oriented normal to the direction of propagation of the initial shock (Figure 7).

2.11.6 Calibration Curve "C2." Choose calibration curve "C2" to determine side-on overpressure when rupture occurs. This curve correlates side-on overpressure with rupture for .001-in. foil, with the plane of the foil oriented normal to the direction of propagation of the initial shock (Figure 8).

2.11.7 Calibration Curve "C3." Choose calibration curve "C3" to determine side-on overpressure when only deformation occurs. This curve correlates side-on overpressure with deformation for .001-in. foil, with the plane of the foil oriented normal to the direction of propagation of the initial shock (Figure 9).

2.11.8 Calibration Curve "D." This curve correlates side-on overpressure with deformation for .003-in. foil (Figure 10). Use curve labeled "side-on" when the foil plane is to be oriented parallel to the direction of propagation of the initial shock. Use curve labeled "face-on" when the foil plane is to be oriented normal to the direction of propagation of the initial shock.

2.11.9 Calibration Curve "E." This curve correlates side-on overpressure with deformation for .005-in. foil (Figure 11). Use curve labeled "side-on" when the foil plane is to be oriented parallel to the direction of propagation of the initial shock. Use curve labeled "face-on" when the foil plane is to be oriented normal to the direction of propagation of the initial shock.

TABLE 1

Summary of Calibration Curve Derivation and Use

CALIBRATION CURVE DESIGNATION	CALIBRATION	DETERMINATION
A	Face-On vs. Side-On Overpressure	Face-On Overpressure from Observed Side-On Overpressure
B1	Side-On Overpressure vs. Deformation or Rupture; .0005-in. Foil in Normal Plane	Side-On Overpressure .0005-in. Foil Deformation or Rupture
B2	Side-On Overpressure vs. Rupture; .0005-in. Foil in Normal Plane	Side-On Overpressure .0005-in. Foil when Rupture Occurs
B3	Side-On Overpressure vs. Deformation; .0005-in. Foil in Normal Plane	Side-On Overpressure .0005-in. Foil Deformation Only
C1	Side-On Overpressure vs. Deformation or Rupture; .001-in. Foil in Normal Plane	Side-On Overpressure .001-in. Foil Deformation or Rupture
C2	Side-On Overpressure vs. Rupture; .001-in. Foil in Normal Plane	Side-On Overpressure When Rupture Occurs
C3	Side-On Overpressure vs. Deformation; .001-in. Foil in Normal Plane	Side-On Overpressure Deformation Only
D	Side-On Overpressure vs. Deformation; .003-in. Foil	With Foil Labeled "Side-On" for Plane Parallel to Shock With Foil Labeled "Face-On" for Normal Plane
E	Side-On Overpressure vs. Deformation; .005-in. Foil	With Foil Labeled "Side-On" For Plane Parallel to Shock With Foil Labeled "Face-On" for Normal Plane

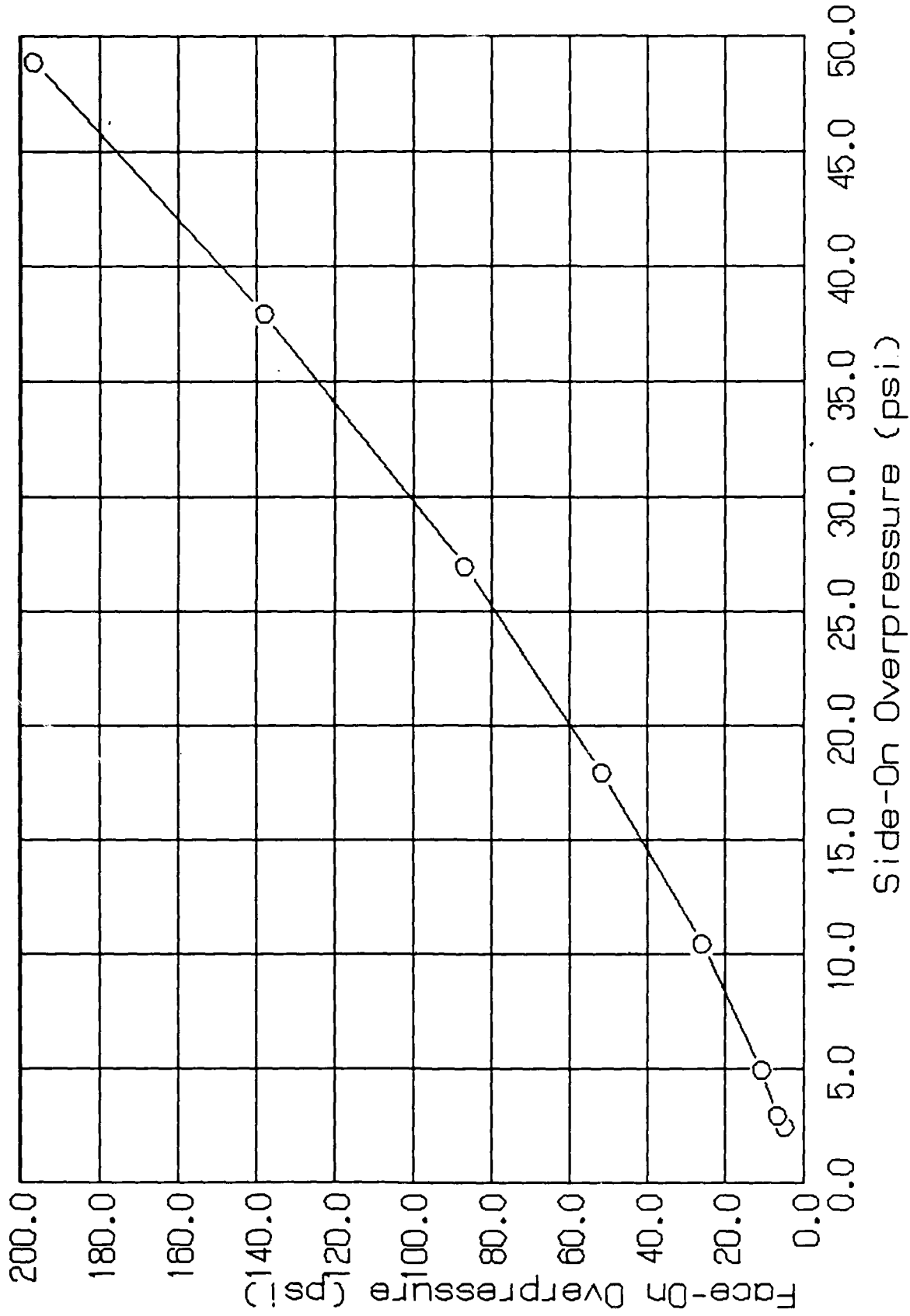

Figure 3. (U) CORRELATION CURVE A
 Face-On versus Side-On Overpressure

.0005 Inch Foil in NDDPG

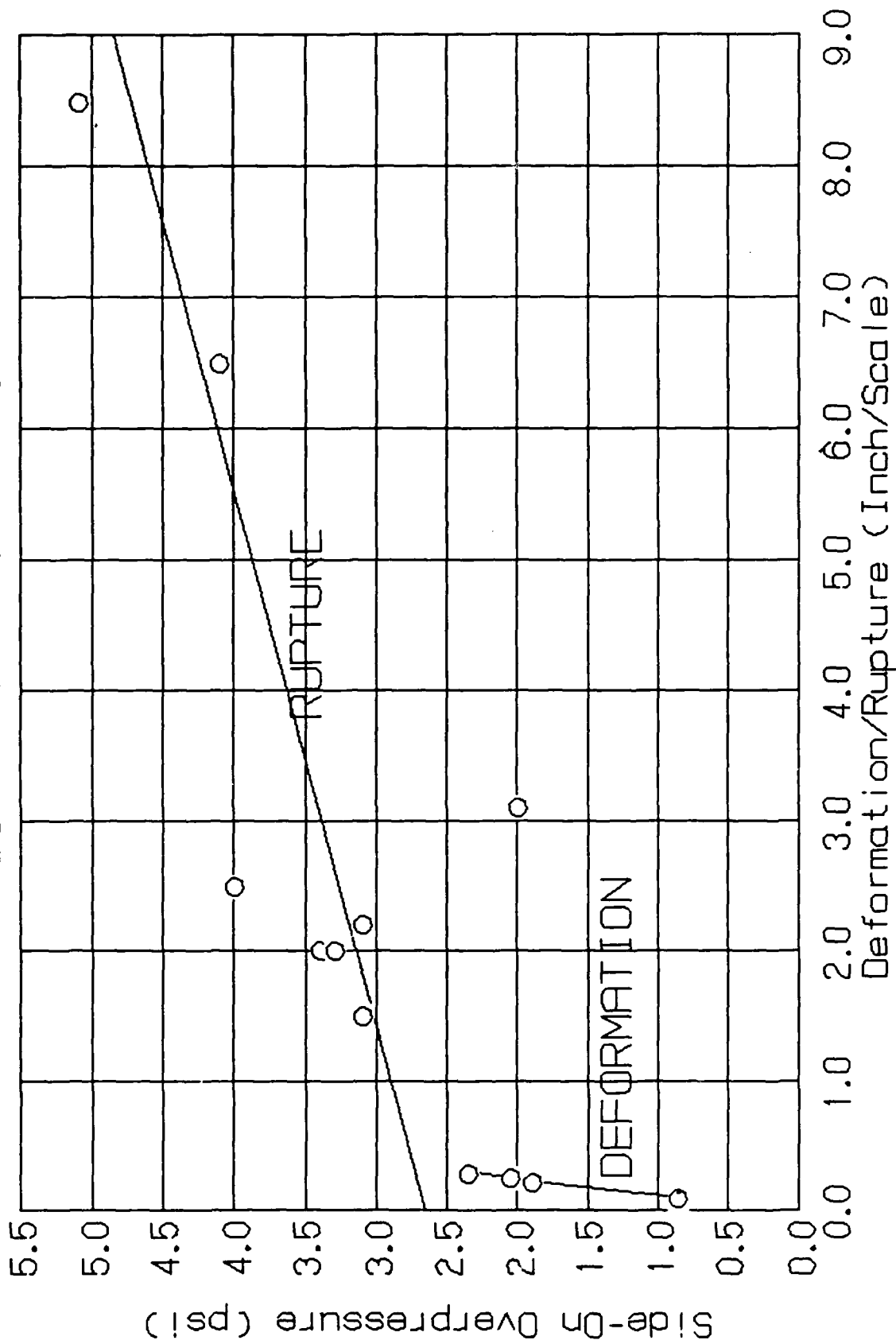

Figure 4. (U) CORRELATION CURVE B-1
Side-On Overpressure versus Deformation
or Rupture

.0005 Inch Foil in NDDPG

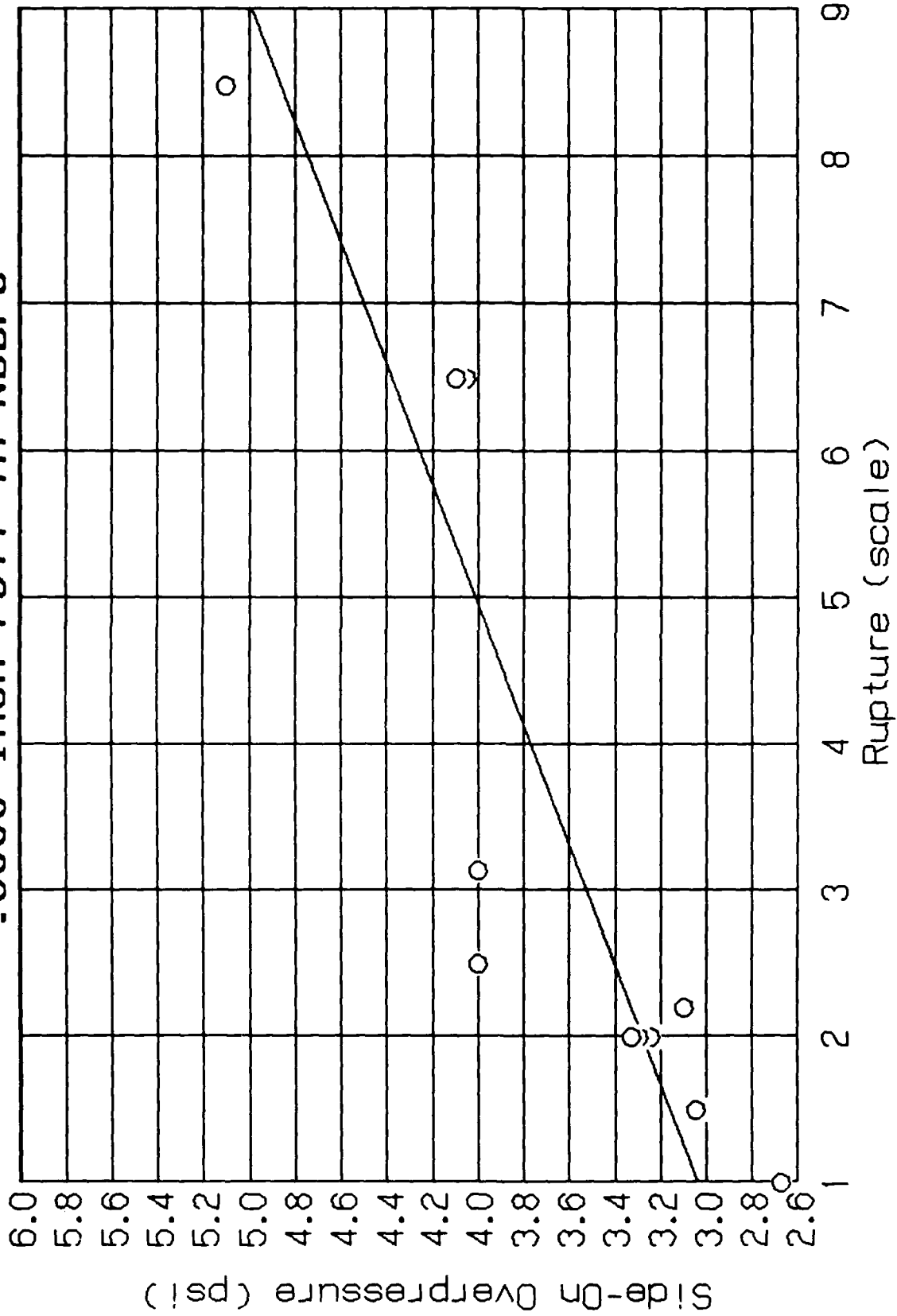

Figure 5.(U) CORRELATION CURVE B-2
Side-On Overpressure versus Rupture

.0005 Inch Foil in NDDPG

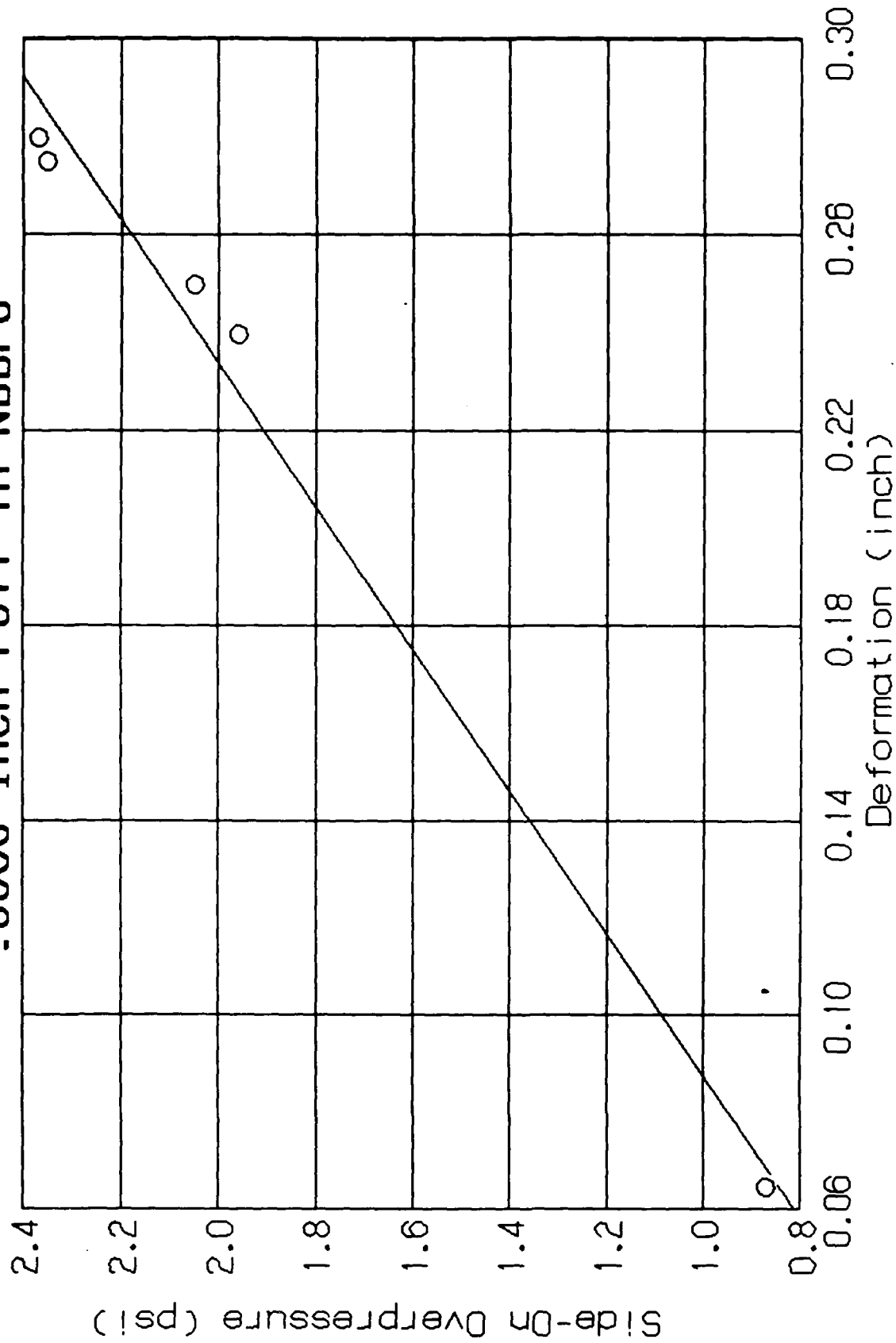

Figure 6. (U) CORRELATION CURVE B-3

Side-On Overpressure versus Deformation

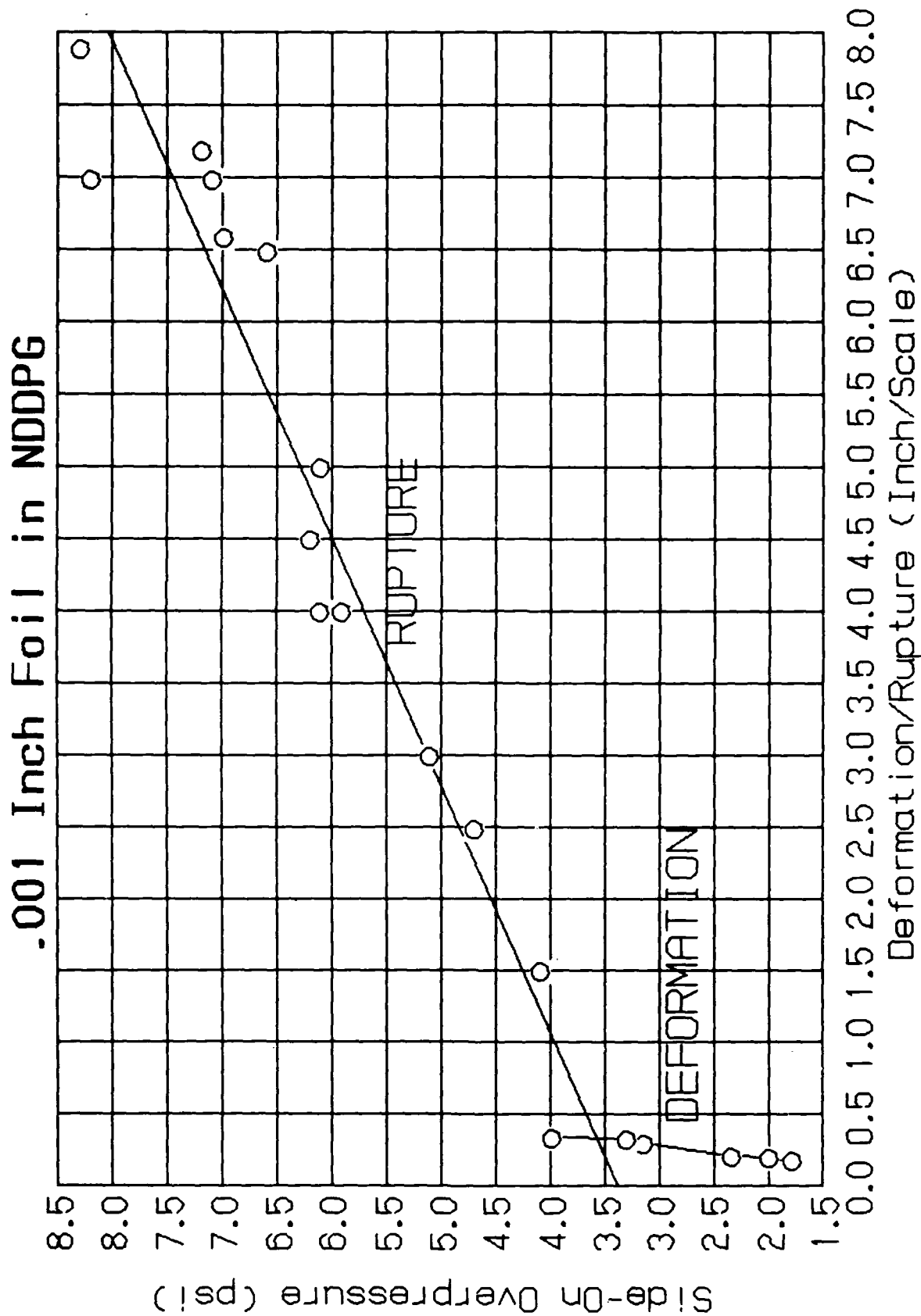

Figure 7. (U) CORRELATION CURVE C-1
 Side-On Overpressure versus Deformation
 or Rupture

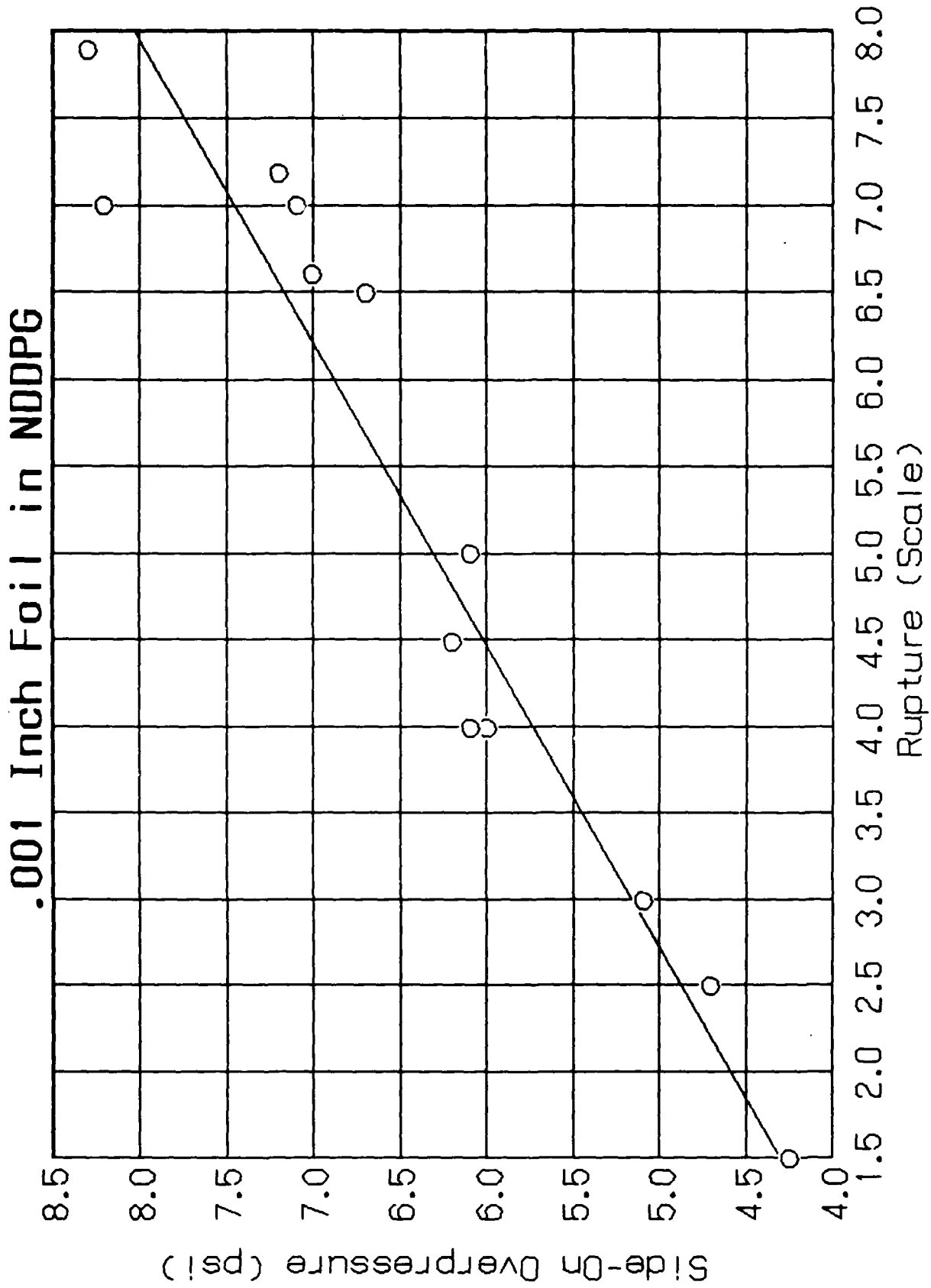

Figure 8. (U) CORRELATION CURVE C-2
Side-On Overpressure versus Rupture

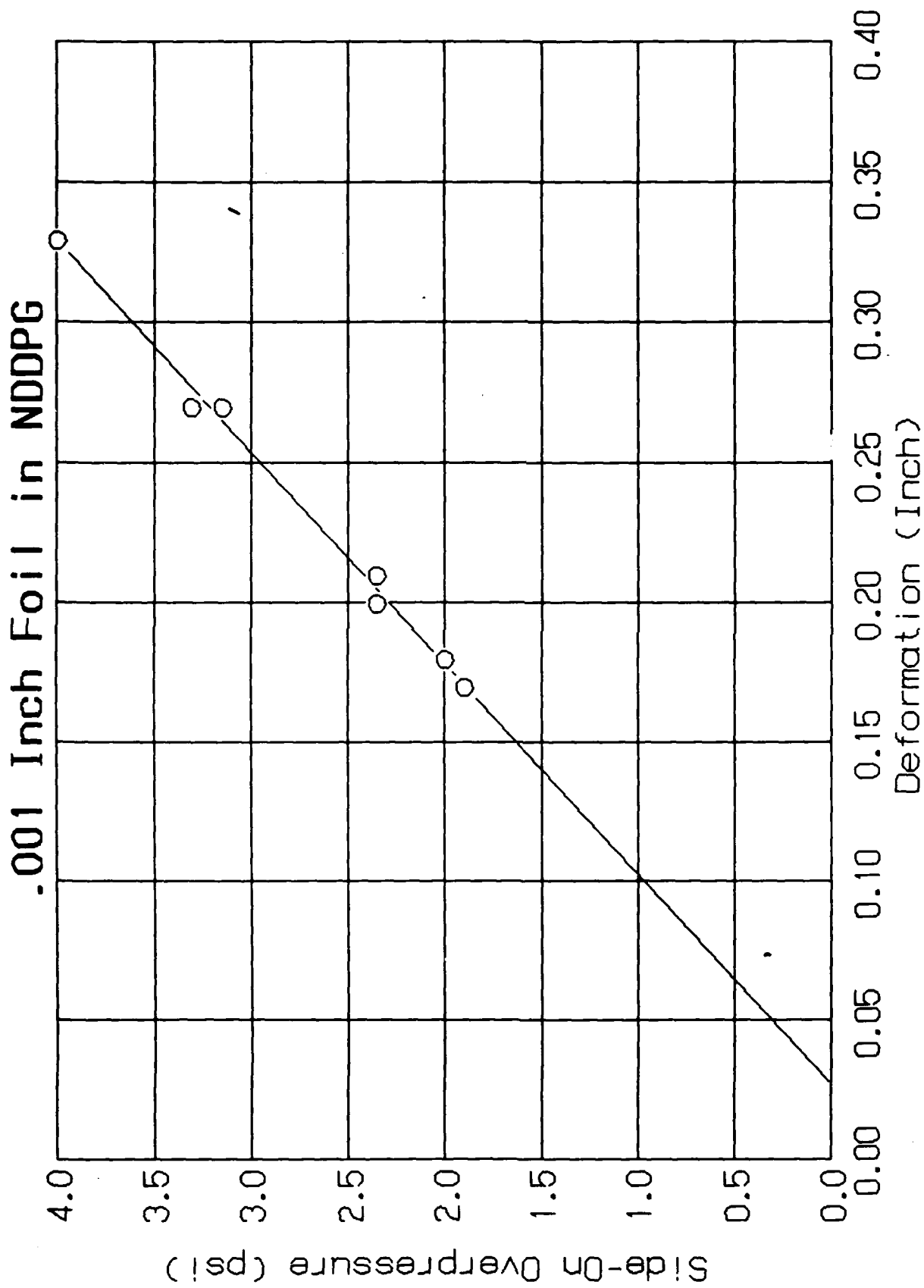

Figure 9. (U) CORRELATION CURVE C-3
Side-On Overpressure versus Deformation

.003 Inch Foil in NDDPG

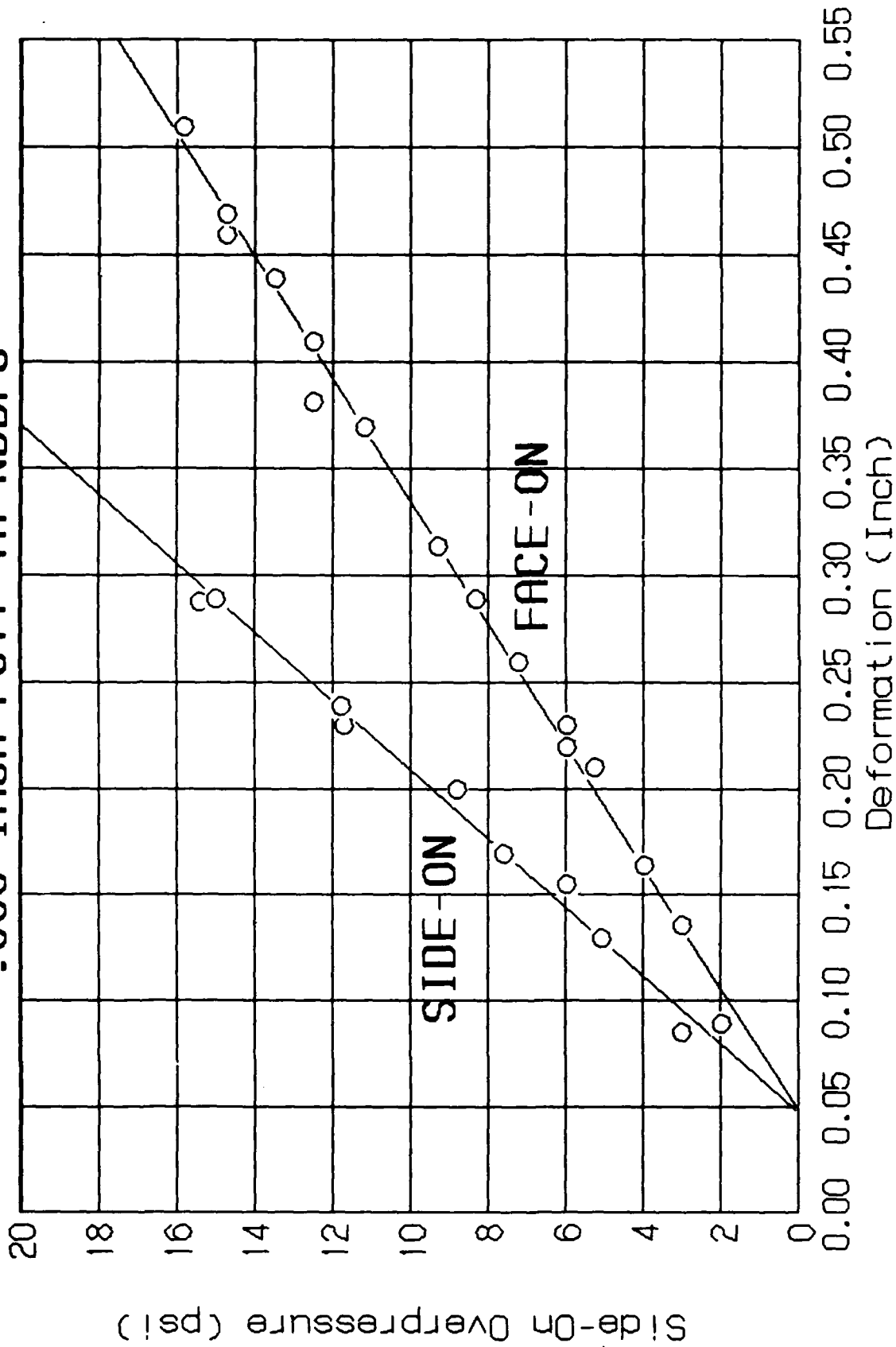

Figure 10. (U) CORRELATION CURVE D

Side-On and Face-On Overpressure versus Deformation

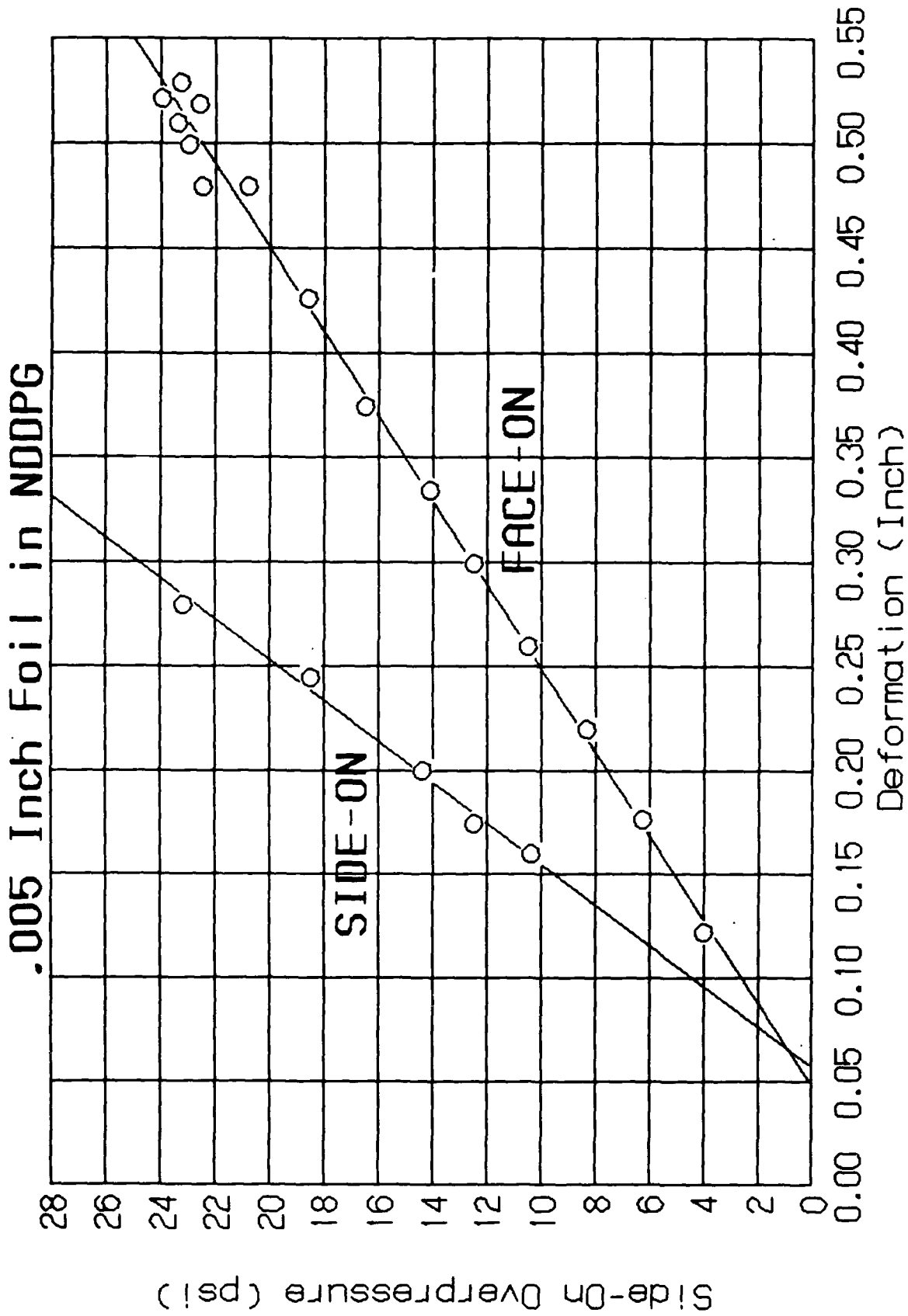

Figure 11. (U) CORRELATION CURVE E
 Side-On and Face-On Overpressure versus
 Deformation

3.0 OPERATING INSTRUCTIONS: QUASI-STATIC DIAPHRAGM PRESSURE GAGE (QSDPG)

3.1 Selection of Foil. An estimate of expected maximum overpressure determines the appropriate foil thickness. Using previous experimental data, estimate an expected maximum overpressure. Select a calibration curve (Figure 14) that incorporates an overpressure range approximately 10 to 25 percent greater than the estimate. Install the foil correlated with the chosen calibration curve. Please note that any new foil must be pure, annealed aluminum and must be calibrated before using (1).

3.2 Installation of Foil. The appropriate thickness of foil is sandwiched between the pressure gage front and rear chambers (see Figure 12, end view, and Figure 13 for details). Remove the cover plate, which is distinguishable from the back plate by a one-inch shock attenuation pipe. Place Silastic 732RTV adhesive/sealant (or equivalent) on the top of the rear chamber plate. Attach the foil with the sealant, centering it over the chamber. When marking the foil with thickness information, test number, etc., use a permanent marker on a surface away from the exposed area of the foil. Place the cover plate over the foil, using no sealant; using a sharp instrument such as an awl or an ice pick, punch holes in the foil to align with the screw holes in the cover plate. Replace the screws, attaching the cover plate.

3.3 Attachment of Gage Housing to Gage Mount. The gage is mounted on a paddle-type gage mount for experimental use. Insert the screws completely through the gage housing and back cover plate before attaching the housing to the mount. Verify that the chamber behind the foil is covered by either the back plate or the gage-mount paddle. The back plate may be omitted when a solid-paddle gage mount is used.

3.4 Gage Orientation for Blast Experiment in a Compartment. The QSDPG can be oriented for compartmented detonation, explosive or shaped charge detonation, and impaction outside the compartment at one of its walls.

3.4.1 Small Charge Detonated Inside Compartment. The QSDPG permits omnidirectional orientation of the foil with respect to shock propagation inside a test compartment. Place the gage inside the compartment with the attenuation tube pointing in any direction.

(1) A source is: International Foils
2081 McCrea Street
Alliance, Ohio 44601
(216) 823-1700

3.4.2 Explosive or Shaped Charge Detonated or Impacting Outside Compartment. The QSDPG permits omnidirectional orientation of the foil with respect to shock propagation outside a test compartment at one of its walls. Place the gage inside the compartment with the attenuation tube pointing in any direction.

3.5 Auxiliary Equipment. Measuring peak quasi-static overpressure inside a compartment requires the use of a depth-gage micrometer and a recording form.

3.6 Deformation Measurement. Measuring peak quasi-static overpressure inside a compartment is a five-step process. Remove the cover plate, which contains the shock attenuation tube. Let air into the gage chamber by raising the foil at the narrow end of the chamber or by making a pinhole in the foil at the entrance area. If the foil is not convex, push the foil down to a configuration where permanent deformation is not altered. Position the micrometer on the foil at the large area of gage housing to reckon the maximum deformation depth or maximum opening. Measure depth (D) from the surface of the foil. Please note that no quasi-static pressure can be determined if the foil ruptures. Therefore, a pressure range should be determined that eliminates the potential for rupture.

3.7 Peak Quasi-Static Overpressure Values. Determining peak overpressure value for a given blast requires the use of an appropriate calibration curve. With reference to Figure 14, use the curve labeled with the corresponding thickness of foil used.

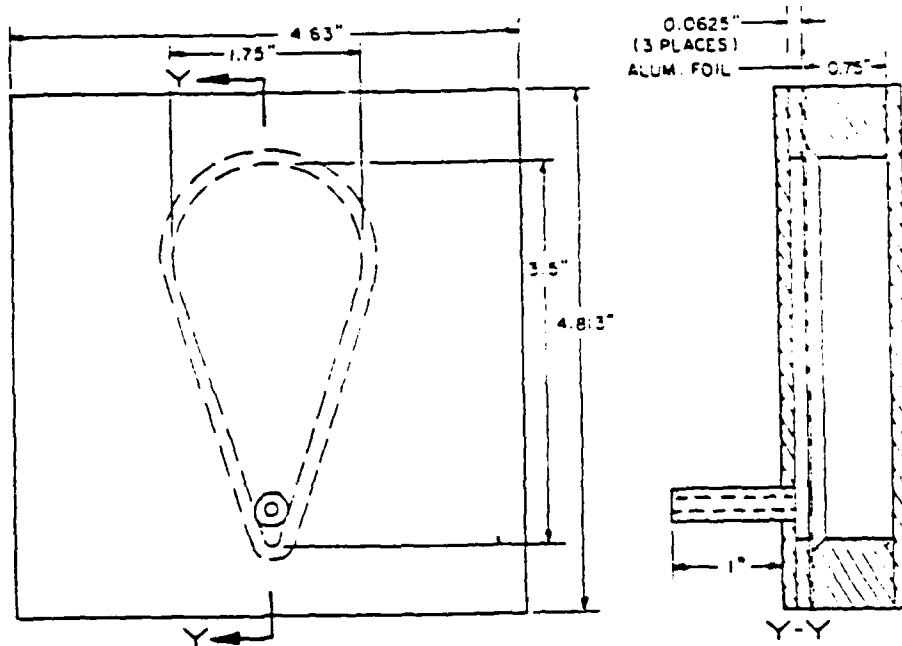

Figure 12. End View--Quasistatic Diaphragm Pressure Gage (QS-DPG).

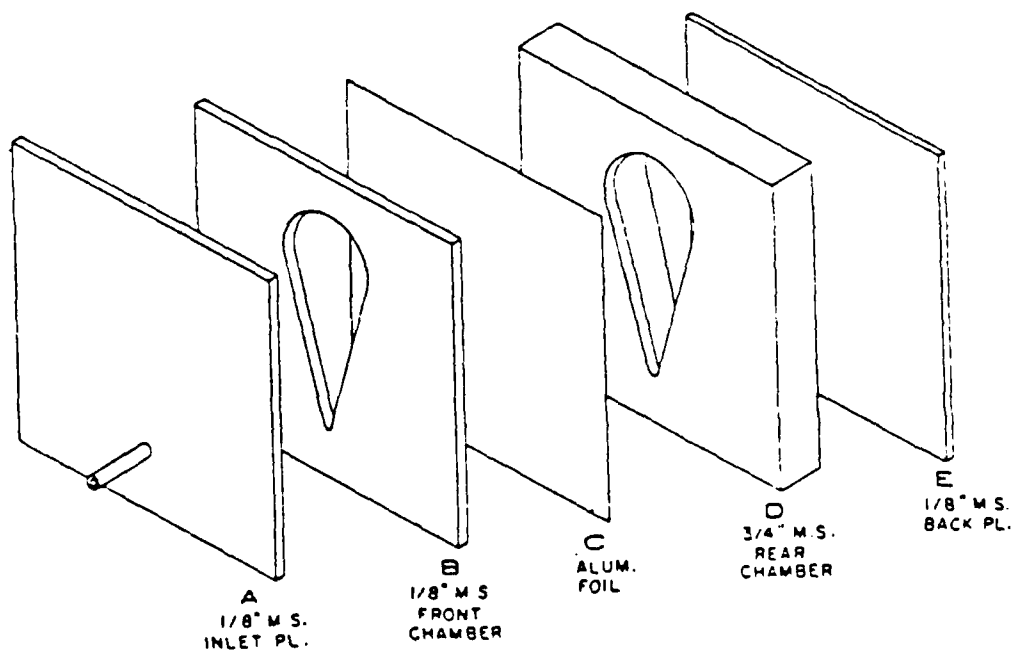

Figure 13. (U) Construction Plan View of the Quasistatic Diaphragm Pressure Gage (QS-DPG).

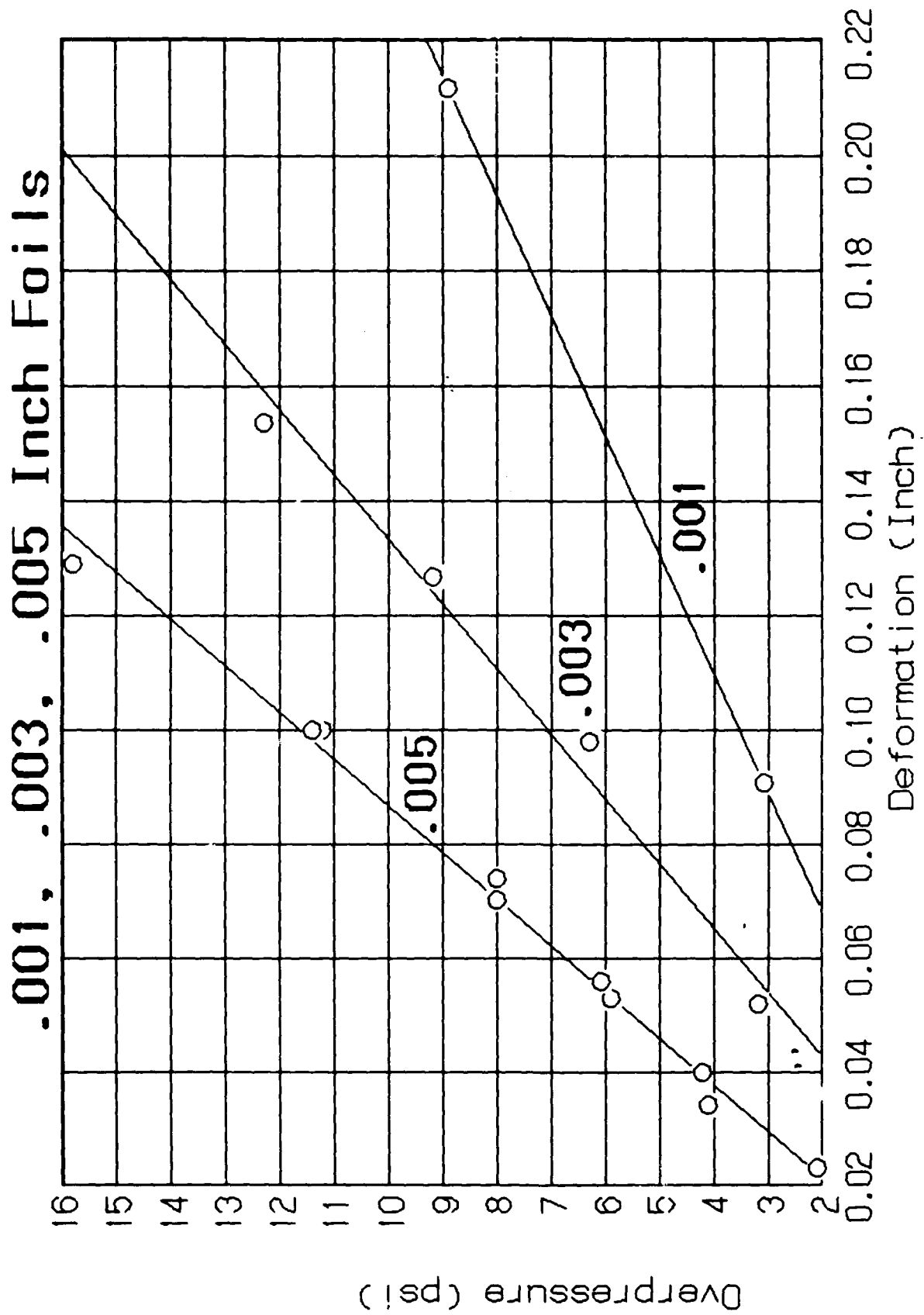

Figure 14. (U) CORRELATION CURVE QS-DPG
Overpressure versus Deformation

DISTRIBUTION LIST

- 12 Administrator
Defense Technical Info Center
ATTN: DTIC-DDA
Cameron Station
Alexandria, VA 22304-6145
- 1 HQDA (DAMA-ART-M)
Washington, DC 20310
- 1 Commander
US Army Material Command
ATTN: AMCDRA-ST
5001 Eisenhower Avenue
Alexandria, VA 22333-0001
- 1 Commander
Armament R&D Center
US Army AMCCOM
ATTN: SMCAR-TSS
Dover, NJ 07801
- 1 Commander
Armament R&D Center
US Army AMCCOM
ATTN: SMCAR-TDC
Dover, NJ 07801
- 1 Director
Benet Weapons Laboratory
Armament R&D Center
US Army AMCCOM
ATTN: SMCAR-LCB-TL
Watervliet, NY 12189
- 1 Commander
US Army Armament, Munitions and
Chemical Command
ATTN: SMCAR-ESP-L
Rock Island, IL 61299
- 1 Commander
US Army Aviation Research
and Development Command
ATTN: AMSAV-E
4300 Goodfellow Blvd.
St. Louis, MO 63120

DISTRIBUTION LIST (Cont.)

- 1 AFWL/SUL
Kirtland AFB, NM 87117
- 1 AFATL/DLODL
Eglin AFB, FL 32542-5000
- 10 Central Intelligence Agency
Office of Central Reference
Dissemination Branch
Room GE-47 HQS
Washington, DC 20502
- 1 Commander
US Army Test and Evaluation
Command
ATTN: AMSTE-TO-F
APG, MD 21005
- 1 Director
US Army Material Systems
Analysis Activity
ATTN: AMXS4-D
ATTN: AMXS4-MP
APG, MD 21005-5071

USER EVALUATION SHEET/CHANGE OF ADDRESS

This laboratory undertakes a continuing effort to improve the quality of the reports it publishes. Your comments/answers below will aid us in our efforts.

1. Does this report satisfy a need? (Comment on purpose, related project, or other area of interest for which the report will be used.) _____

2. How, specifically, is the report being used? (Information source, design data, procedure, source of ideas, etc.) _____

3. Has the information in this report led to any quantitative savings as far as man-hours or dollars saved, operating costs avoided, or efficiencies achieved, etc? If so, please elaborate. _____

4. General Comments. What do you think should be changed to improve future reports? (Indicate changes to organization, technical content, format, etc.) _____

BRL Report Number _____ Division Symbol _____

Check here if desire to be removed from distribution list. _____

Check here for address change. _____

Current address: Organization _____
Address _____

-----FOLD AND TAPE CLOSED-----

Director
U.S. Army Ballistic Research Laboratory
ATTN: SLCBR-DD-T (NEI)
Aberdeen Proving Ground, MD 21005-5066



NO POSTAGE
NECESSARY
IF MAILED
IN THE
UNITED STATES

OFFICIAL BUSINESS
PENALTY FOR PRIVATE USE \$300

BUSINESS REPLY LABEL
FIRST CLASS PERMIT NO. 12062 WASHINGTON D C

POSTAGE WILL BE PAID BY DEPARTMENT OF THE ARMY

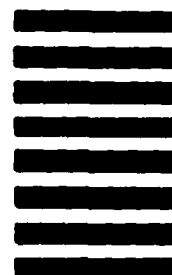

Director
U.S. Army Ballistic Research Laboratory
ATTN: SLCBR-DD-T (NEI)
Aberdeen Proving Ground, MD 21005-9989