

DTIC FILE COPY

4

AD-A203 360

# FOULING TESTS OF AGT-1500 GAS TURBINE FUEL NOZZLES

INTERIM REPORT  
BFLRF No. 258

By

L.G. Dodge

L.L. Stavinoha

H.W. Marbach, Jr.

Belvoir Fuels and Lubricants Research Facility (SwRI)  
Southwest Research Institute  
San Antonio, Texas

Under Contract to

U.S. Army Belvoir Research, Development  
and Engineering Center  
Materials, Fuels and Lubricants Laboratory  
Fort Belvoir, Virginia

Contract No. DAAK70-87-C-0043

Approved for public release; distribution unlimited

September 1988

DTIC  
ELECTE  
27 JAN 1989  
S D  
cb E

89 1 27 013

### **Disclaimers**

**The findings in this report are not to be construed as an official Department of the Army position unless so designated by other authorized documents.**

**Trade names cited in this report do not constitute an official endorsement or approval of the use of such commercial hardware or software.**

### **DTIC Availability Notice**

**Qualified requestors may obtain copies of this report from the Defense Technical Information Center, Cameron Station, Alexandria, Virginia 22314.**

### **Disposition Instructions**

**Destroy this report when no longer needed. Do not return it to the originator.**

Unclassified

SECURITY CLASSIFICATION OF THIS PAGE

**REPORT DOCUMENTATION PAGE**

1a. REPORT SECURITY CLASSIFICATION Unclassified			1b. RESTRICTIVE MARKINGS		
2a. SECURITY CLASSIFICATION AUTHORITY N/A			3. DISTRIBUTION/AVAILABILITY OF REPORT Approved for public release; distribution unlimited		
2b. DECLASSIFICATION/DOWNGRADING SCHEDULE N/A			4. PERFORMING ORGANIZATION REPORT NUMBER(S) Interim Report BFLRF No. 258		
4. PERFORMING ORGANIZATION REPORT NUMBER(S) Interim Report BFLRF No. 258			5. MONITORING ORGANIZATION REPORT NUMBER(S)		
6a. NAME OF PERFORMING ORGANIZATION Belvoir Fuels and Lubricants Research Facility (SwRI)		6b. OFFICE SYMBOL (If applicable) N/A	7a. NAME OF MONITORING ORGANIZATION		
6c. ADDRESS (City, State, and ZIP Code) Southwest Research Institute 6220 Culebra Rd. San Antonio, Texas 78284			7b. ADDRESS (City, State, and ZIP Code)		
8a. NAME OF FUNDING/SPONSORING ORGANIZATION U.S. Army Belvoir Research, Development and Engineering Center		8b. OFFICE SYMBOL (If applicable) STRBE-VF	9. PROCUREMENT INSTRUMENT IDENTIFICATION NUMBER DAAK70-85-C-0007, WD 8; DAAK70-87-C-0043, WD 2		
8c. ADDRESS (City, State, and ZIP Code) Fort Belvoir, VA 22042			10. SOURCE OF FUNDING NUMBERS		
	PROGRAM ELEMENT NO. 62786	PROJECT NO. 1L76278-6AH20	TASK NO. VM	WORK UNIT ACCESSION NO.	
11. TITLE (Include Security Classification) Fouling Tests of AGT-1500 Gas Turbine Fuel Nozzles (U)					
12. PERSONAL AUTHOR(S) Dodge, Lee G.; Stavinoha, Leo L.; and Marbach, Howard W., Jr.					
13a. TYPE OF REPORT Interim		13b. TIME COVERED FROM Sept 86 to Sept 88		14. DATE OF REPORT (Year, Month, Day) 1988 September	15. PAGE COUNT 30
16. SUPPLEMENTARY NOTATION					
17. COSATI CODES			18. SUBJECT TERMS (Continue on reverse if necessary and identify by block number)		
FIELD	GROUP	SUB-GROUP	AGT-1500,	Fuel Nozzle,	Additives,
			Nozzle Fouling,	Gas Turbine Nozzle,	Fuel Additives.
			Diesel Fuel,	Fuel Nozzle Fouling,	Fuel Deposits.
19. ABSTRACT (Continue on reverse if necessary and identify by block number)					
<p>AGT-1500 gas turbine engines have experienced significant starting problems due to fuel nozzle fouling. The first objective of these tests was to evaluate the effects of fuel additives on deposit formation in fuel injectors for combustors in AGT-1500 gas-turbine engines. A second objective was to determine what other standard ASTM or bench-type tests could be used to predict the full-scale fouling results without the expense of the full-scale tests. A third objective was to evaluate solvents and cleaners for removing the deposits.</p> <p>A 125-cycle start-up, run, and shutdown test was used in full-scale tests to evaluate fuel nozzle fouling during the shutdown heatsoak period. Two standard Cat 1-H reference fuels with different thermal stability characteristics were tested. Nozzle fouling was much worse with the fuel of lower</p> <p>(Continued on back)</p>					
20. DISTRIBUTION/AVAILABILITY OF ABSTRACT <input type="checkbox"/> UNCLASSIFIED/UNLIMITED <input checked="" type="checkbox"/> SAME AS RPT. <input type="checkbox"/> DTIC USERS			21. ABSTRACT SECURITY CLASSIFICATION Unclassified		
22a. NAME OF RESPONSIBLE INDIVIDUAL Mr. T.C. Bowen			22b. TELEPHONE (Include Area Code) (703) 664-3576	22c. OFFICE SYMBOL STRBE-VF	

19. ABSTRACT (Continued from front page)

thermal stability. The Cat 1-H fuel with poorer thermal stability was used as the base fuel for tests with three additives that had been shown to be effective in preventing fouling in diesel engines. The additives significantly reduced fouling in the secondary fuel nozzles, but made no improvement or degraded performance in the primary fuel nozzles. Thus, fuel nozzle fouling mechanisms vary for the primary and secondary nozzles. Fouling in the primary nozzles is probably more significant relative to starting problems in the AGT-1500 engine.

In addition to the full-scale combustor tests, a Phillips microburner bench test was used to determine fuel deposition levels with the base and additive-treated fuels. Data for external soot and internal lacquer on combustion tubes were used to evaluate a number of additives promoted as capable of reducing combustion deposits in diesel engines.

The fouling results for the full-scale combustor tests are compared with the results for standard ASTM tests and other bench-scale tests.

## FOREWORD/ACKNOWLEDGMENTS

This work was performed by the Belvoir Fuels and Lubricants Research Facility (BFLRF) located at Southwest Research Institute (SwRI), San Antonio, Texas under Contract Nos. DAAK70-85-C-0007 and DAAK70-87-C-0043 with the Belvoir Research, Development and Engineering Center. Messrs. F.W. Schaekel and T.C. Bowen of Belvoir RDE Center (STRBE-VF) served as the contracting officer's representatives, and Mr. M.E. LePera, Chief of Fuels and Lubricants Research Division (STRBE-VF), served as the project technical monitor.

Messrs. R.C. Haufler and M.G. Ryan conducted the AGT-1500 tests. Mr. E.R. Lyons performed the microburner tests. Ms. L. Bundy coordinated the fuels tests. Ms. S.J. Hoover performed the manuscript preparation with the editorial assistance of Mr. J.W. Pryor. Mr. S. J. Lestz provided assistance in contract management.

Accession For	
NTIS GRA&I	<input checked="" type="checkbox"/>
DTIC TAB	<input type="checkbox"/>
Unannounced	<input type="checkbox"/>
Justification	
By _____	
Distribution/	
Availability Codes	
Dist	Avail and/or Special
A-1	

## TABLE OF CONTENTS

<u>Section</u>	<u>Page</u>
I. INTRODUCTION AND BACKGROUND .....	1
II. OBJECTIVES .....	5
III. EXPERIMENTAL APPROACH .....	5
A. Full-Scale Nozzle Fouling Tests .....	6
B. Microburner Fouling Tests .....	13
IV. DISCUSSION OF RESULTS .....	16
A. Full-Scale Nozzle Fouling Tests .....	16
B. Microburner Test Results .....	23
C. Solvents for Deposit Removal .....	26
V. SUMMARY AND CONCLUSIONS .....	29
VI. RECOMMENDATIONS .....	29
VII. LIST OF REFERENCES .....	29

## LIST OF ILLUSTRATIONS

<u>Figure</u>		<u>Page</u>
1	One-piece Fuel Nozzle for AGT-1500 Gas-Turbine Engine .....	3
2	Two-piece Fuel Nozzle for AGT-1500 Gas-Turbine Engine .....	4
3	Photograph of AGT-1500 Combustor Installation .....	6
4	Phillips Microburner .....	15
5	Comparison Between 1968 and 1986 Data for Phillips Microburner .....	16
6	AGT-1500 Fuel Nozzle Temperature During Shutdown-Soakback Period .....	17
7	Photograph of Secondary and Primary Nozzles After 25 Test Cycles .....	18
8	Degradation of Flow Capacity of Primary Fuel Nozzles During 125-Cycle Test .....	20
9	Degradation of Flow Capacity of Secondary Fuel Nozzles During 125-Cycle Test .....	20
10	Comparison of Microburner Tube Deposits With Additive C .....	24
11	Comparison of Microburner Tube Deposits With Additives A, B, and D .....	25
12	Sectioned Tip of Primary Nozzle Showing Complex Spring Loaded Internal Piston With Swirl Channel .....	28

## LIST OF TABLES

<u>Table</u>		<u>Page</u>
1	Fuel Flows and Pressure Drops for Standard Operating Conditions of AGT-1500 Combustor .....	1
2	Identification of AGT-1500 Nozzles .....	7
3	Airflow Requirements for AGT-1500 Combustor Using Two-Piece Fuel Nozzle .....	7
4	Fuel Properties at Time of Receipt .....	9

LIST OF TABLES (Continued)

<u>Table</u>		<u>Page</u>
5	Additive Effects on Fuel Thermal Stability Using Standard Rating Methods .....	10
6	Description of Additive Packages .....	11
7	Conditions for Nozzle Fouling Tests .....	12
8	Degradation in Flow Rates for AGT-1500 Atomizers for Various Fuels After 125-Cycle Test .....	19
9	Relative Comparison of Fouling Tendencies of Base Fuel and Fuel With Additives .....	21
11	Spray Test Results With Fouled AGT-1500 Primary Atomizers .....	23
12	Blends Evaluated With Microburner .....	25
13	Solvent Effectiveness for Cleaning Fouled AGT-1500 Nozzle Parts .....	27

## I. INTRODUCTION AND BACKGROUND

AGT-1500 gas turbine engines have experienced significant starting problems due to deposit buildup both on exterior and interior surfaces of the fuel injectors. The fuel injectors consist of a primary nozzle used for starting and flame stabilization and a higher flow rate secondary nozzle used to provide the majority of the fuel flow at higher power conditions. Fuel flow rates through the primary and secondary fuel nozzles are shown in TABLE 1 (for the current production 2-piece nozzle). The primary nozzle is a pressure-swirl atomizer relying on fuel pressure for atomization, and having a specified flow number (flow rate/ $\sqrt{\text{pressure differential}}$ ) of 2.90 to 3.06 pound mass/hour (lbm/hr)  $\sqrt{\text{psid}}$  on aircraft fuel system calibration fluid (MIL-C-7024, Type II). The conversion to units of kg/s  $\sqrt{\text{kPa}}$  is to multiply by  $4.80 \cdot 10^{-5}$ . The secondary nozzle is an airblast type, relying on the air pressure drop across the combustor can to provide high velocity air to atomize the fuel. The flow number of the secondary is approximately 45 lbm/hr  $\sqrt{\text{psid}}$ .

TABLE 1. Fuel Flows and Pressure Drops for Standard Operating Conditions of AGT-1500 Combustor (2-piece nozzle design)

	Start-up		Low Idle 40 hp	High Idle 400 hp	1050 hp	Max 1500 hp
	5% Speed	20% Speed				
Primary Fuel Flow, g/s lbm/hr	4.7 37	5.5 44	5.2 41	6.4 51	7.8 62	8.4 67
Primary $\Delta P$ (fuel)(approx.) kPa psid	1062 154	1503 218	1303 189	2020 293	2985 433	3482 505
Secondary Fuel Flow, g/s lbm/hr	0.4 3	3.3 26	2.5 20	27.2 216	56.7 450	82.7 656
Total Fuel Flow, g/s lbm/hr	5.0 40	8.8 70	7.7 61	33.6 267	64.5 512	91.1 723
Air Pressure Drop, kPa psid inches H <sub>2</sub> O	0.07 0.01 0.27	0.54 0.079 2.2	5.1 0.736 20.4	12.1 1.75 48.4	17.3 2.51 69.5	22.1 3.21 88.9

According to the engine manufacturer, the starting problems are related to the fuel deposits on the interior of the primary nozzle and the exterior of the nozzle affecting the spray from the primary. For the conventional 1-piece nozzle design, exterior surfaces are cleaned after 40 to 60 hours to reestablish the fuel spray cone, and after 200 hours the interior of the primary nozzle requires cleaning or replacement. Cleaning procedures usually provide only a temporary improvement with the 1-piece nozzle design, with the nozzle soon clogging again. When fuel flow rates in the primary nozzle drop to about 47 percent of normal (17 lbm/hr instead of 36.5 lbm/hr at 150 psid) due to fouling, the probability of a successful start is 50 percent.

It has been established by the manufacturer that the nozzle fouling is not due to continuous operation, but is rather a shutdown, heat-soakback problem that results in fuel coking within the atomizer, and fuel dripping from the downward pointing nozzle after shutdown. This dripping fuel ignites and then coats the exterior of the atomizer with soot. This fuel drip and ignition add additional heat load to the atomizer.

The manufacturer has developed three improvements in hardware and procedures to alleviate the nozzle fouling problems. First, the engine should be run at idle before shutdown to reduce engine and exhaust heat recuperator temperatures. Second, the fuel control has been improved to reduce dripping after shutdown. Third, the fuel nozzle and combustor housing have been redesigned in four ways to reduce problems associated with nozzle fouling: (a) the 1-piece nozzle, shown in Fig. 1, was redesigned as a 2-piece nozzle, shown in Fig. 2, for easier cleaning; (b) the flow divider valve, which is subject to fouling and sticking and makes cleaning difficult, has been removed from the nozzle and located external to the combustor; (c) there are better thermal characteristics for the new nozzle design, and the nozzle is thermally insulated at the mount; and (d) air for airblast atomization comes directly from the compressor rather than the recuperator, reducing the air (and nozzle) temperature and increasing the pressure available.

The status on these improvements is as follows. The increased-idle-time shutdown procedure is recommended and widely used. The improved fuel controls have apparently been installed. However, the new 2-piece nozzles and redesigned cover plates are only gradually being retrofitted into the existing M1 tanks. In the meantime, significant problems remain in achieving successful start-ups in these tanks.

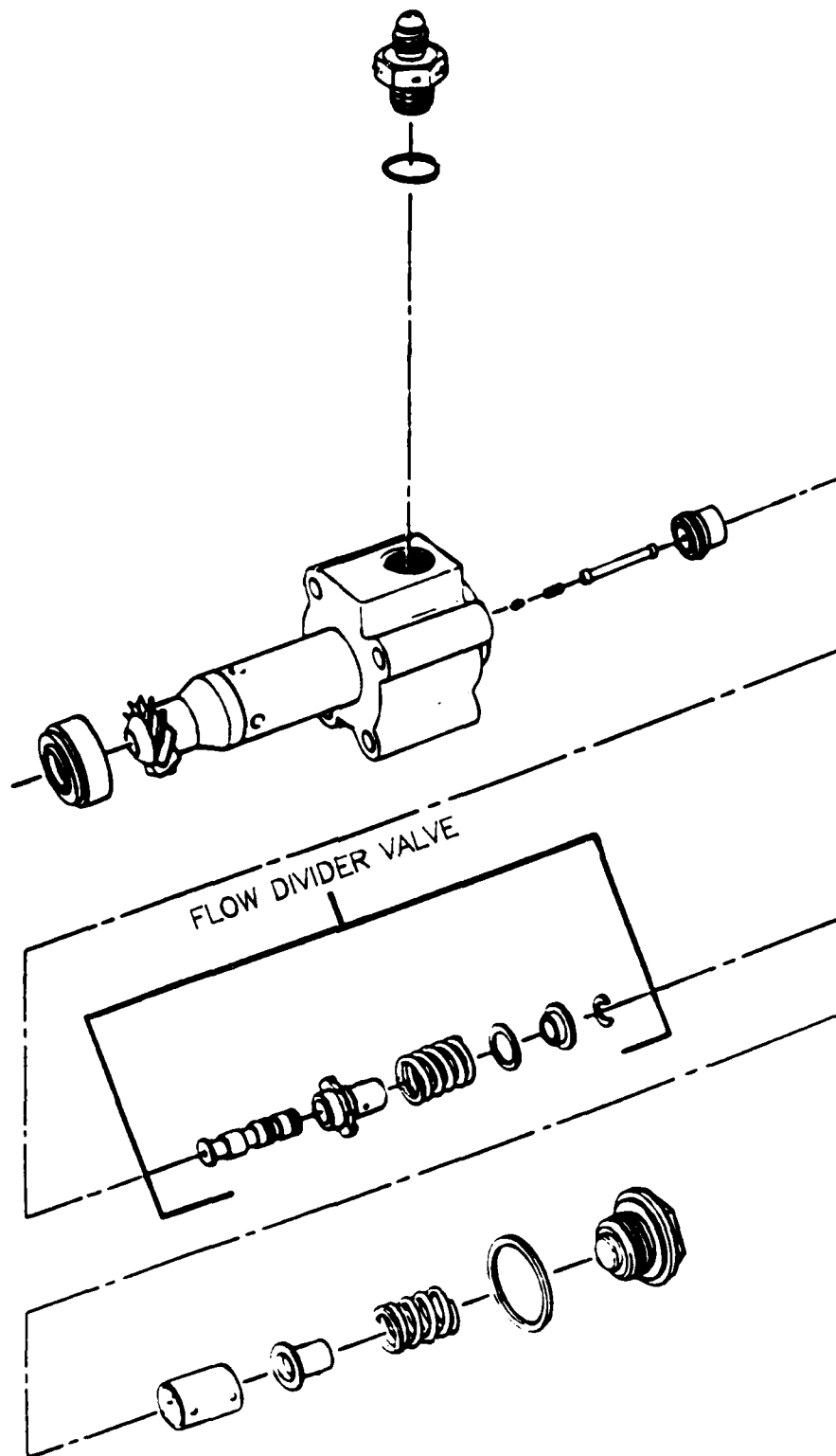

Figure 1. One-piece fuel nozzle for AGT-1500 gas-turbine engine  
(no longer in production)

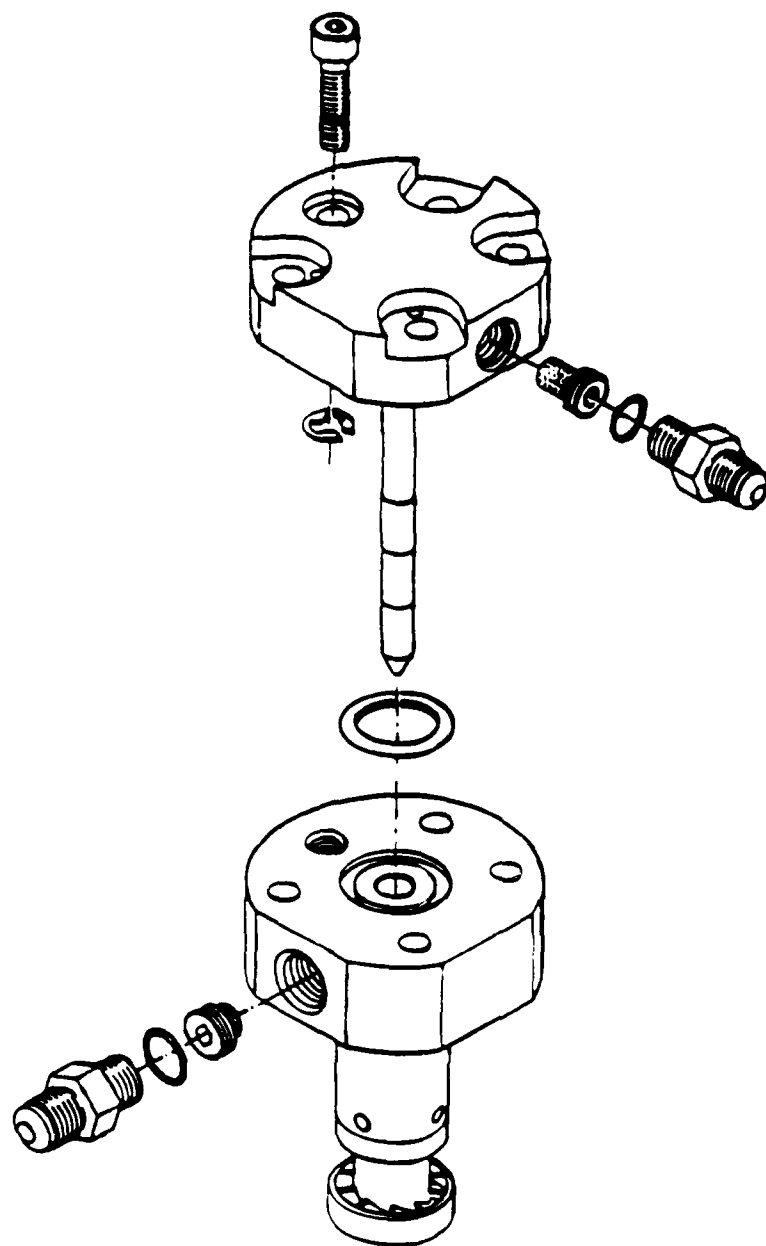

Figure 2. Two-piece fuel nozzle for AGT-1500 gas-turbine engine  
(current production version)

## II. OBJECTIVES

The first objective of these tests was to evaluate the effects of fuel additives on deposit formation in fuel injectors for combustors in AGT-1500 gas-turbine engines. A second objective was to determine what other standard ASTM or bench-type tests could be used to predict the full-scale fouling results without the expense of the full-scale tests. A third objective was to evaluate solvents and cleaners for removing the deposits.

## III. EXPERIMENTAL APPROACH

Before describing these tests, it is worthwhile considering two other approaches that were tried by the manufacturer, but were unsuccessful in alleviating the nozzle-fouling problem. First, fuels lighter and cleaner than DF-2, such as JP-4, were tested because they have a higher thermal stability than DF-2. However, fouling was as bad or worse with JP-4 because of the specific fouling mechanism in this engine. The JP-4 has a lower boiling point than DF-2, so during heat soakback the JP-4 boils sooner and forces fuel out of the nozzle tip. Further, JP-4 is higher in volatility than DF-2 and ignites at a lower temperature, increasing the chances for spontaneous ignition of the fuel forced out of the nozzle. Thus, although JP-4 is a cleaner and more thermally stable fuel than DF-2, the use of JP-4 does not improve nozzle fouling characteristics during shutdown.

A second unsuccessful approach was to use purge air to blow all the fuel out of the atomizer during shutdown. A 50-cubic-inch reservoir at compressor discharge pressure was used for fuel purging. Using this purge, about 3 seconds were required to remove the majority of the fuel from the nozzle and another 20 to 25 seconds of airflow should have provided fairly complete fuel removal. However, fuel fouling still occurred, with nozzle temperatures going higher during the soakback period due to the loss of the heat sink effect of the fuel.

This report describes the full-scale AGT-1500 combustor tests and fouling tests with a smaller lab-scale flame referred to as a microburner. The fouling tendencies for the fuel-additive mixtures as determined in the full-scale and microburner tests are compared with the results from standard fuel-rating tests. Finally the experience with various solvents and cleaning procedures is discussed.

## A. Full-Scale Nozzle Fouling Tests

### 1. Facility for Full-Scale Tests

Fuel nozzle fouling tests were performed at Belvoir Fuels and Lubricants Research Facility (BFLRF) at Southwest Research Institute with a full AGT-1500 combustor (see Fig. 3) using a newer style, 2-piece fuel nozzle (see Fig. 2) prepared by the engine manufacturer and the corresponding new combustor cover plate design. The 2-piece fuel nozzle was selected for several reasons. First, the 1-piece nozzles are no longer manufactured, and unused nozzles are very difficult to obtain. Second, as shown in Fig. 1, the flow-divider valve (which controls the flow split between the primary and secondary atomizers) is internal to the 1-piece atomizer, making it difficult to establish whether fouling is occurring in the flow-divider valve, the primary atomizer, or the secondary atomizer. Third, the 2-piece nozzles are easier to partially disassemble and clean. The atomizers used for these tests are identified by number for these tests and by serial number in TABLE 2. The primary and secondary nozzles are separate pieces, each with its own serial number. Nozzle sets 1 and 2 are not listed in TABLE 2. These nozzles were used to gain experience with the fouling mechanism, with cleaning techniques for the nozzles, and to establish the number of test cycles.

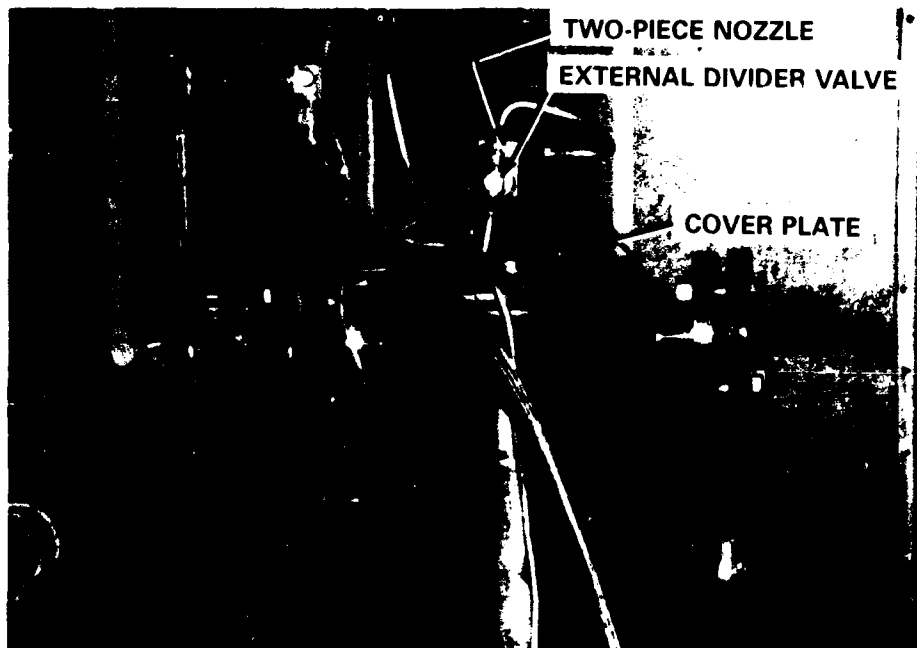

Figure 3. Photograph of AGT-1500 combustor installation

**TABLE 2. Identification of AGT-1500 Nozzles**

<u>Nozzle Set No.</u>	<u>Serial Number, Primary</u>	<u>Serial Number, Secondary</u>
3	0591A	0373B
4	0581A	0385B
5	4114A	4043B
6	4121A	4045B
7	4131A	4032B
8	4134A	4046B

Because the nozzle-fouling problem in this combustor is related to the shutdown, heat-soakback period, a cyclic test was performed to subject the fuel nozzle to a series of shutdowns as described later in this report. The compressor section of the AGT-1500 engine was simulated by compressors and preheaters at the Gas Turbine Combustor Laboratory at Belvoir Fuels and Lubricants Research Facility (SwRI). The maximum available airflow at this facility is 1.1 kg/s (2.5 lbm/s). TABLE 3 shows that

**TABLE 3. Airflow Requirements for AGT-1500 Combustor Using Two-Piece Fuel Nozzle**

		<u>Low Idle 40 hp</u>	<u>High Idle 400 hp</u>	<u>1050 hp</u>	<u>Max. Power 1500 hp</u>
Airflow into Combustor Liner*,	kg/s	0.717	1.70	2.33	3.15
	lbm/s	1.58	3.74	5.13	6.95
Compressor Discharge Pressure,	kPa	254	634	962	1303
	psia	36.8	92.0	139.5	189.0
Inlet Air Temperature, Liner,	°C	316	427	526	516
	°F	600	800	978	960
Inlet Air Temperature, Atomizer,	°C	121	266	337	399
	°F	250	510	639	750

\*Small additional airflow requirement for nozzle.

airflow requirements for the AGT-1500 combustor range from about 0.7 to 3.2 kg/s, with much of this range beyond the available airflow capacity. Thus, the maximum airflow available of 1.1 kg/s was used for these tests at a pressure of 621 kPa (90 psia) and a temperature of 482°C (900°F). These parameters corresponded roughly to the 400-hp condition, except that the temperature was increased relative to standard conditions to increase the heat input to the nozzle and combustor, and the air to both the combustor and the nozzle were at the same temperature as typical of the operating conditions for the 1-piece nozzles (rather than having cooler air for the nozzle as shown in TABLE 3 for the 2-piece nozzles).

In order to perform cyclic tests involving many start-up and shutdown cycles without start-up and shutdown of the air factory, a bypass air system was added to the standard piping system. This addition allowed the heated high-pressure air to be directed through the combustor during the burning phases, and bypassed around the combustor during the shutdown/soakback period.

All test results were recorded with a microcomputer. Test results included inlet air mass flow rate, pressure, and temperature, fuel pressure, temperature and mass flow rate, nozzle flow number (mass flow rate/ $\sqrt{\text{pressure differential}}$ ), combustor outlet temperature, and nozzle body temperature just below the air inlet holes for the airblast air for the secondary nozzles.

Airflow rates were measured with a 3-inch (7.6 cm) turbine flowmeter. The volume flow rates were converted to mass flow rates in the computer system using measured temperature and pressure. All temperatures were measured with type K (chromel-alumel) thermocouples. Pressures were measured with transducers. Fuel flow rates were measured with a Coriolis-Effect flowmeter.

## 2. Test Fuels

Two standard Reference No. 2 diesel fuels (Cat 1-H) (see TABLE 4 for fuel properties at time of receipt) of differing thermal stabilities were tested to determine if these differences would result in differences in fuel nozzle fouling. As discussed earlier, limited tests by the engine manufacturer with JP-4 (which is more stable than diesel fuel) showed fouling to be as severe as for diesel fuel. TABLE 5 shows the significant

TABLE 4. Fuel Properties at Time of Receipt

Test Description	Test Method	Test Results		Cat 1-H Requirements
		AL-15482-F	AL-15706-F	
Gravity, °API	D 1298	34.7	34.1	32 - 35
Distillation, °C	D 86			
IBP		216	213	Report
10% Recovered		244	243	NR*
20% Recovered		255	253	NR
50% Recovered		276	274	260 - 278
90% Recovered		324	322	304 - 327
95% Recovered		337	336	NR
End Point		349	349	343 - 366
Sulfur, wt%	D 4294	0.41	0.41	0.37 - 0.43
Total Acid Number	D 664	0.03	0.03	0.15, max
Cu Corrosion at 50°C	D 130	1A	1A	2, max
Viscosity, cSt @ 37.8°C	D 445	3.35	3.12	3.0 - 4.0
Carbon Residue, 10% bottoms, wt%	D 524			
Water and Sediment, vol%		0.10	0.10	0.20, max
Cloud Point, °C	D 1796	0	0	0.05, max
Pour Point, °C	D 2500	-11	-9	Report
Flash Point, °C	D 97	-12	-9	-6
Flash Point, °C	D 93	88	58	38, min
Cetane Number	D 613	52	50	45 - 51
Cetane Index	D 976	49	47	Report
Accelerated Stability, mg/100 mL				
mg/100 mL	D 2274	--	0.5	NR
Particulate Contaminants, mg/L	D 2276	--	3.0	NR
Ash, wt%	D 482	<0.001	0	0.01, max
Saturates, vol%	D 1319	--	67.5	NR
Olefins, vol%	D 1319	--	2.0	NR
Aromatics, vol%	D 1319	--	30.5	NR
Carbon, wt%	D 3178	--	86.32	NR
Hydrogen, wt%	D 3178	--	12.86	NR
Net Heat of Combustion, MJ/kg				
Btu/lb	D 240	--	42.489	NR
		--	18267	NR

\* NR = No requirement.

differences in thermal stability for the "clean" Cat 1-H (AL-15706-F) and the baseline Cat 1-H (AL-15482-F), as measured by the oxidation stability of distillate fuel test (ASTM D 2274), the jet fuel thermal oxidation test (JFTOT, D 3241), and the deposit-measuring device (DMD). The DMD was developed at BFLRF and provides a quantitative measure of deposit thickness and volume. The Cat 1-H with the lower thermal stability (AL-15482-F) was selected as the baseline fuel for these tests for evaluating additive effectiveness.

TABLE 5. Additive Effects on Fuel Thermal Stability Using Standard Rating Methods

Fuel	Nozzle No.	Fuel No.	Additive Amount	D 2274, mg/100mL	Temp, °C	ΔP, mm Hg	Visual Rating	TDR		Date	Max Thick, cm x 10 <sup>-7</sup>	Vol., cm <sup>3</sup> x 10 <sup>-7</sup>
								Spun Rating	Rating			
"Clean" Cat I-H	3	15706	--	0.5	260	0	2	8 @ 30		4/12/87	--	--
				4.0	260	8 in 150 min	4	19 @ 32		4/28/88	14 @ 30	15
Base Cat I-H	4	15482	--	6.5	260	125 in 145 min	4(A)*	19 @ 30		1/27/88	77 @ 20	262
					280	125 in 39 min	4(P)	30 @ 46		11/18/87	331 @ 42	456
Base + A	5	17369 (17074)	360 mg/L	1.5	260	0	3	17 @ 40		1/13/88	11 @ 52	14
					280	0	4(A)	17 @ 41		1/14/88	62 @ 38	70
Base + B	6	17368 (17080)	8757 mg/L	0.3	260	0	3	18 @ 42		3/3/88	11 @ 2	20
					280	0	4(P)	35 @ 42		3/3/88	408 @ 42	522
Base + C	7	17499 (17112)	71 mg/L	3.0	260	0	4	19 @ 34		3/8/88	20 @ 40	23
					280	2 in 145 min	> 4(P)	27 @ 36-48		3/10/88	128 @ 58	206

\*(A) = Abnormal  
(P) = Peacock

### 3. Additive Packages

Three additive packages were added to the baseline fuel in three separate tests, using the concentrations recommended by manufacturers. The coded additive packages used in this program are described in TABLE 6. The complete compositions are proprietary. As shown in TABLE 5, these additives significantly improved the thermal stability characteristics of the fuel as measured by the oxidative stability test (D 2274), the filter plugging (pressure drop) part of the JFTOT test, and the DMD test at the lower test temperature (260°C). At 280°C, only Additive A greatly improved the DMD results relative to the base fuel, while Additive C registered a more modest improvement.

---

TABLE 6. Description of Additive Packages

<u>Code</u>	<u>Brief Description</u>
A	Multifunctional additive package includes detergent/dispersant, lubricity improver, corrosion inhibitor, and stabilizer
B	An ashless dispersant based on polyamine ether chemistry for deposit removal/control
C	Multifunctional additive package includes rust inhibitor, dispersant, antioxidant, color stabilizer, and metal deactivator
D	Multifunctional additive package includes smoke suppressant, lubricity improver, detergent/dispersant, stabilizer, and biocide

---

### 4. Test Procedures

Each fuel nozzle and test fuel was subjected to a 125-cycle start-up, run, shutdown, heat-soakback test. During each cycle, the combustor was operated at the test conditions shown in TABLE 7 for 5 minutes, followed by a shutdown, heat-soakback period of 10 minutes. After fuel shutoff, the airflow through the combustor was reduced from that shown in TABLE 7 to zero flow in about 15 seconds by closing the exhaust valve on the combustor exit and opening a bypass valve. A 30-second period was

---

**TABLE 7. Conditions for Nozzle Fouling Tests**

Air mass flow, kg/s	1.1
lbm/s	2.5
Air pressure, kPa	621
psid	90
Air inlet temperature, °C	482
(both combustor and °F	900
fuel nozzle)	
Fuel Flow, g/s	9.83
lbm/m	1.30

---

required to return the flow through the combustor and reestablish the flame. Ignition was established as airflow was increasing through the combustor. The fuel flow and airflow were quickly increased to the flow conditions shown in TABLE 7. The 5-minute run cycle was at those steady-state conditions.

Degradation of nozzle performance was evaluated in two ways. The standard test for fuel nozzle fouling is a measure of loss of flow rate at constant fuel pressure. This test was performed for both the primary and secondary atomizers in each fuel nozzle. In addition to determining changes in fuel nozzle flow capacity, a second test was used to evaluate changes in atomization performance. Atomization performance was characterized as the average drop size produced by the primary nozzle at a fixed fuel pressure.

To evaluate changes in fuel nozzle flow characteristics, each atomizer was calibrated for flow rate versus pressure differential before the beginning of the 125-cycle test, at the conclusion of the test, and at four or five intermediate points. Calibration measurements at the beginning and end of the test period included both Cat 1-H diesel fuel (AL-15482-F) and aircraft fuel system calibration fluid (special-blend Stoddard solvent MIL-C-7024, Type II). The aircraft fuel system calibration fluid was used because it is the industry standard and the nozzles were specified based on that fluid. The diesel fuel was used because the engine normally runs on diesel fuel. Atomizer flow

rate characteristics were documented in terms of flow number, which is the mass flow rate divided by the square root of the pressure differential. Conventional units are pounds per hour/ $\sqrt{\text{psid}}$ , and the conversion to units of  $\text{kg/s}\sqrt{\text{kPa}}$  is to multiply by  $4.80 \cdot 10^{-5}$ . Flow number was used to document decreases in flow capacity because it automatically corrects for variations in pressure differential.

To calibrate the flow through the primary and secondary atomizers independently, it was necessary to add extra valves and tubing to bypass the flow divider valve. The primary nozzles were calibrated at a pressure differential of 1034 kPa (150 psid). At that pressure the specified flow rate is 4.47 to 4.73 g/s (35.5 to 37.5 lbm/hr), corresponding to flow numbers of  $1.39$  to  $1.47 \cdot 10^{-4} \text{ kg/s}\sqrt{\text{kPa}}$  ( $2.90$  to  $3.06 \text{ lbm/hr}\sqrt{\text{psid}}$ ). The secondary fuel nozzle was calibrated by establishing a flow of 15.1 g/s (2.00 lbm/m) and measuring the required pressure differential, which was on the order of 48 kPa differential (7 psid), corresponding to a flow number of about  $2.2 \times 10^{-3} \text{ kg/s}\sqrt{\text{kPa}}$  ( $45 \text{ lbm/hr}\sqrt{\text{psid}}$ ). A specification on the flow number for the secondary is not available. Because of the low-pressure differential involved, the precision of measurement of the flow capacity for the secondary nozzle was less than the precision for the primary, as shown in the results section.

To evaluate changes in atomization performance, measurements of average drop size in terms of Sauter mean diameter or surface/volume mean diameter (1)\* were performed for all the nozzles at the end of the test and compared with the results for a new nozzle. These measurements were performed using a laser-diffraction, particle-sizing instrument that measured drop-size distributions integrated along the intersection of the laser beam and the fuel spray. This integral line-of-sight value does not represent an accurate cross-section average drop size (2), but does allow for a relative evaluation of the effects of nozzle fouling.

#### B. Microburner Fouling Tests

In addition to the full-scale nozzle fouling tests, a microburner was used to evaluate deposit-forming tendencies of the various fuels and additives. This test is more complicated and expensive than standard fuel rating tests, but is much less expensive

\*Underscored numbers in parentheses refer to the list of references at the end of this report.

than the full-scale tests described in the previous section. The results of the microburner tests are compared with the standard rating tests and the full-scale tests at the conclusion of this section.

### 1. Microburner Apparatus

The Phillips microburner is a bench-scale apparatus of unique design for evaluating the burning quality of gas turbine and jet engine fuels.<sup>(3)</sup> Conditions for combustion found in full-scale turbojet engines are simulated (to an extent) in the microburner, but it requires less fuel, time, and equipment than full-scale combustors. Minimum test fuel requirements are less than one pound, total time requirements less than one hour, and sufficiently small airflow requirement to make the microburner suitable for use by a normal control laboratory. Additionally, this combustor is capable of satisfactory operation with fuels varying in volatility from gasoline through No. 2 fuel oil. The apparatus (Fig. 4) has been used with a number of pure hydrocarbon compounds to correlate deposition rates with metal-loss rates.<sup>(4)</sup>

### 2. Test Procedures

To reestablish the Phillips microburner as a method for evaluating fuel deposition characteristics, it was installed in a test cell and run under the following conditions:

Inlet Air Velocity	9.1 m/s (30 ft/sec)
Inlet Air Temperature	299°C (550°F)
Base Pressure	227.5 ± 1.7 kPa (33.0 ± 0.25 psig)
Fuel/Air Ratio	0.070
Fuel Consumption	200 g, 400 g (see text)

After removing the deposit tube from the microburner base, it was reweighed for total deposits. The outside tube deposits were wiped clean and reweighed again to provide the inside tube deposits.

Figure 5 illustrates the comparison between April 1968 data as reported in Reference 5 and the more current data, which demonstrate a relationship between fuel aromatic content and outside deposit levels on the test tube.

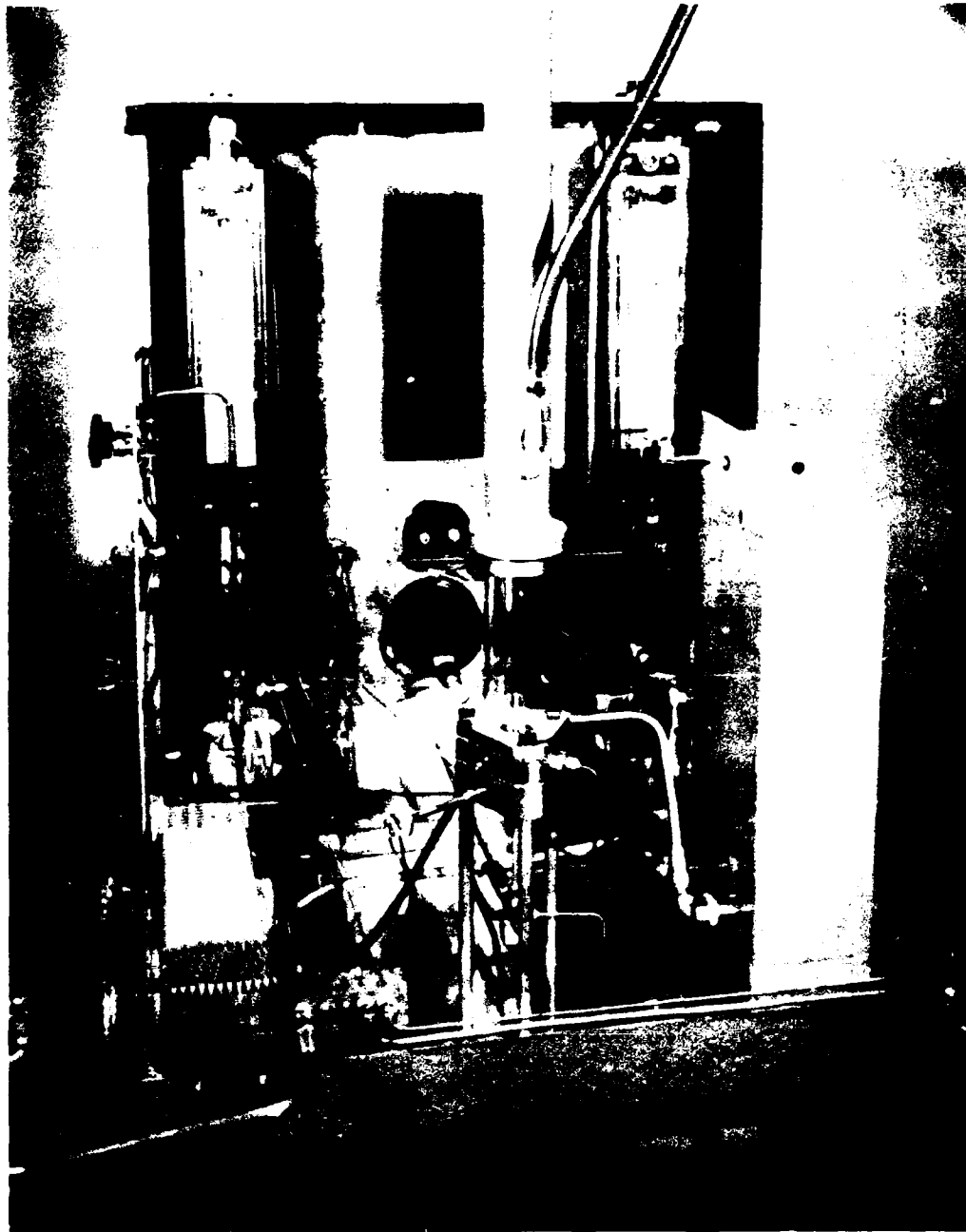

Figure 4. Phillips microburner

For additive evaluations, a higher fuel consumption (400 g rather than 200 g) test condition was chosen to emphasize internal lacquer-type deposits rather than the external (tube) soot deposits, which more readily flake off due to the high magnitude of deposits with this quantity of fuel.

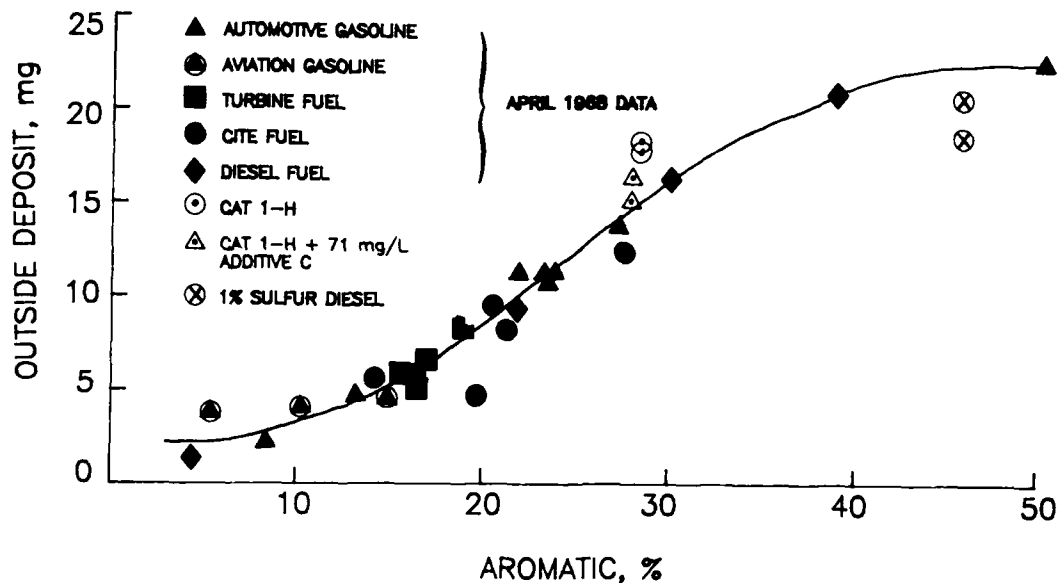

Figure 5. Comparison between 1968 and 1986 data for Phillips microburner

#### IV. DISCUSSION OF RESULTS

##### A. Full-Scale Nozzle Fouling Tests

During operation, the fuel atomizer is cooled by the fuel. At shutdown, the fuel flow stops and the combustor begins to cool but the atomizer heats up due to the loss of fuel cooling. Atomizer temperatures vary with sensing location. For these tests, a thermocouple was located just below (downstream of) the inlet holes for the air for the secondary nozzle. The temperature was about 182°C (360°F) while the combustor was burning, but this temperature increased to a peak of about 377° to 446°C (711° to 834°F) about 150 seconds after shutdown, with a typical profile as shown in Fig. 6.

For about one-half of the cycles, a visible flash or series of flashes occurred as the nozzle heated up following shutdown. This flash occurred typically at a nozzle temperature (where measured) of about 325°C (617°F), which was reached about 45 to 60

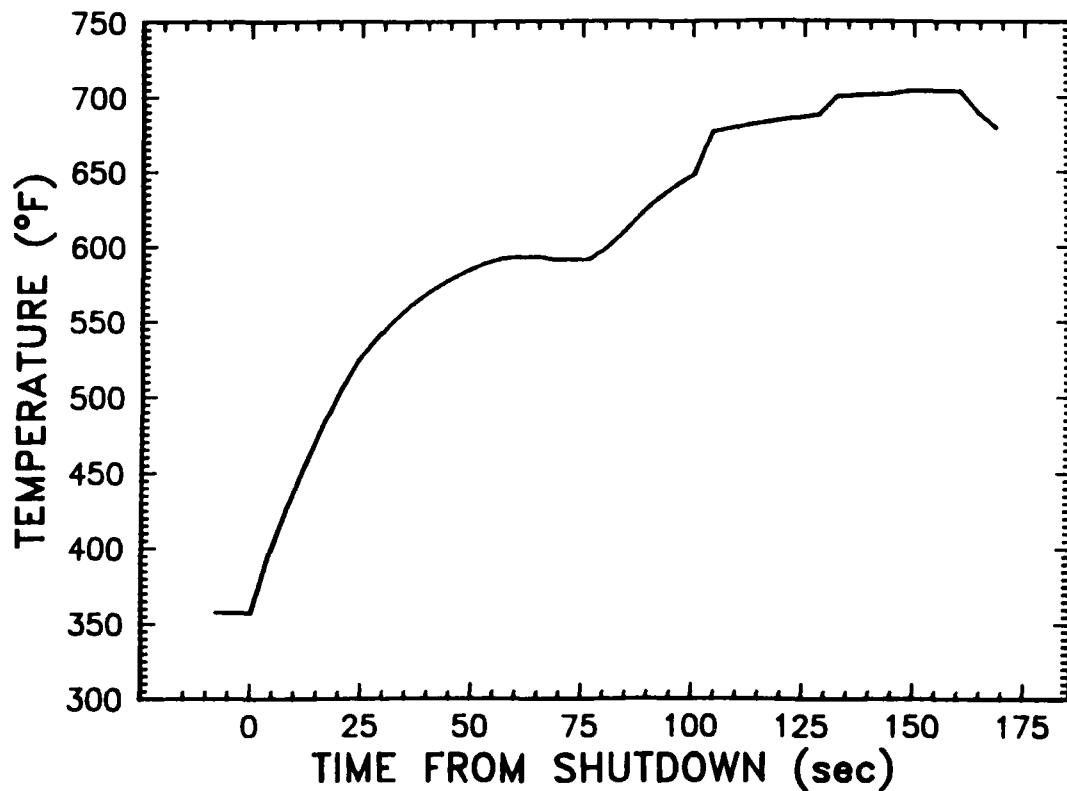

**Figure 6. AGT-1500 fuel nozzle temperature during shutdown-soakback period.**  
(thermocouple location on outside of nozzle just below inlet holes for  
airblast air for secondary)

seconds after shutdown. The engine manufacturer explained this as the result of fuel that remained in the nozzle heating up and boiling and forcing some of the fuel out of the nozzle, which then spontaneously ignited on the tip of the hot nozzle. This combustion led to sooty deposits on the outside of the atomizer (see Fig. 7), and also added heat to the nozzle, which presumably caused or accelerated internal fuel fouling.

In addition to the sooty deposits formed on the outside of the nozzle, internal fouling of both primary and secondary nozzles was evident by the reduction in fuel flow rate at constant fuel pressure. As discussed earlier, fuel flow capacity was measured in terms of flow number. For all fuels tested for 125 cycles, the flow capacity decreased due to internal fouling for both the primary and secondary atomizers. TABLE 8 shows the flow number before and after each test as well as the percentage loss in flow rate at constant pressure. Figures 8 and 9 show the degradation of flow capacity as a function of test cycles for the primary and secondary nozzles, respectively.

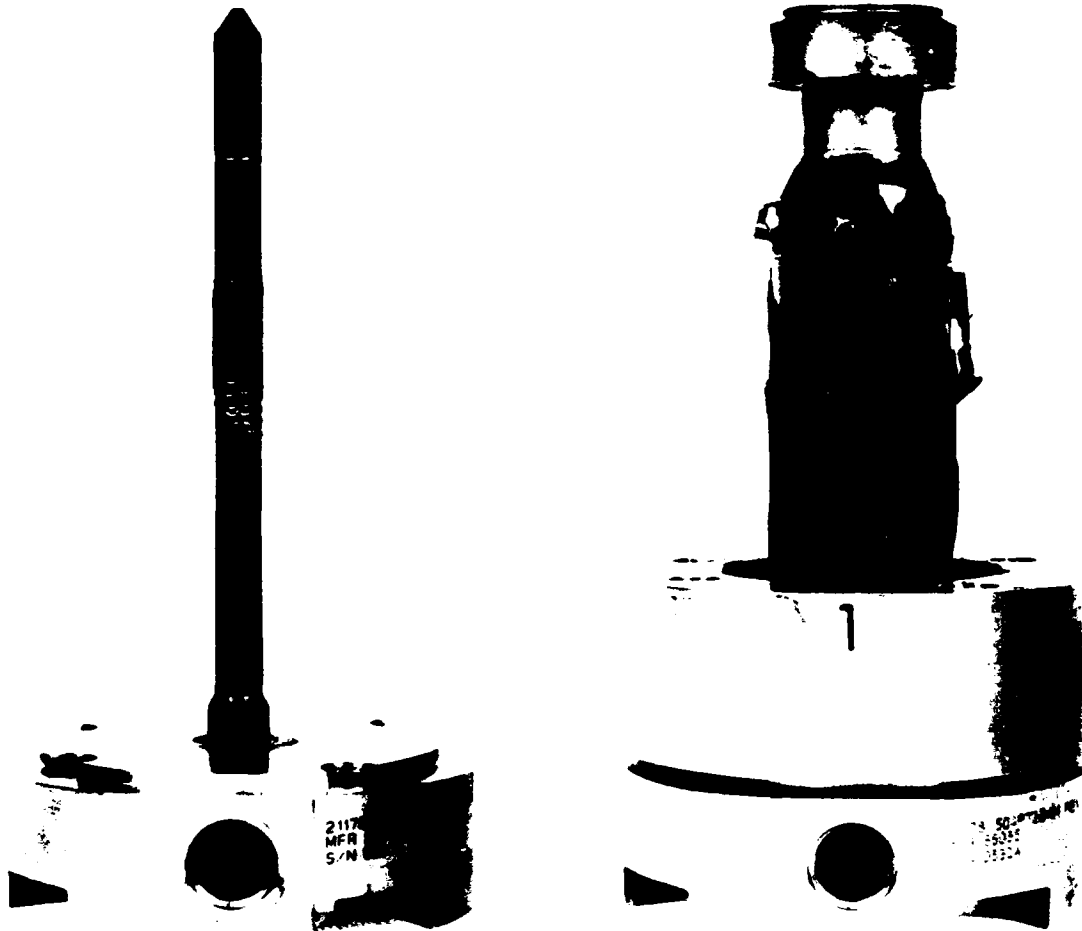

a. Primary nozzle

b. Secondary nozzle

**Figure 7. Photograph of primary and secondary nozzles after 25 test cycles**

These results in a realistic combustion environment with engine hardware confirm that for the two standard Cat I-H fuels without additives that the JFTOT test results (D 3241), the oxidation stability of distillate fuel test (D 2274) and the DMD test may be reasonable predictors for fouling in the nozzle. All three tests indicate that fuel 15706 is superior to 15482 in stability, and the results shown in TABLE 9 indicate fouling in both the primary and secondary nozzles is significantly worse for the 15482 fuel. (Microburner tests, reported in a following section, showed the opposite to be true.)

As shown in TABLE 5, the addition of additives to the base fuel (15482) resulted in improved test results for all three additives on tests D 2274, D 3241, and the DMD, except for Additive B (fuel 17368) at 280°C. Additive B showed a slight degradation

**TABLE 8. Degradation in Flow Rates for AGT-1500 Atomizers  
for Various Fuels After 125-Cycle Test**

Nozzle Number	No. 3 "Clean"	No. 4 Base	No. 5	No. 6	No. 7
Test Fuel	Cat 1-H	Cat 1-H	Base + A	Base + B	Base + C
<u>Test Fuel AL No.</u>	<u>15706</u>	<u>15482</u>	<u>17369</u>	<u>17368</u>	<u>17499</u>
<b>Primary Nozzle:</b>					
Calibration Fluid (MIL-C-7024, Type II)					
Flow Number, New*	2.95	2.94	3.07	3.09	2.90
Flow Number, End of Test	2.82	2.55	2.73	2.63	2.05
% Loss in Flow	4.4	13.3	11.1	14.9	29.3
Cat 1-H (AL-15482-F, Base)					
Flow Number, New	3.31	3.38	3.72	3.45	3.53
Flow Number, End of Test	3.14	2.84	3.01	2.68	2.21
% Loss in Flow	5.1	16.0	19.1	22.3	37.4
Average % Loss in Flow For Primary Nozzle	4.8	14.7	15.1	18.6	33.4
<b>Secondary Nozzle:</b>					
Calibration Fluid (MIL-C-7024, Type II)					
Flow Number, New	50.8	49.3	49.3	49.9	48.6
Flow Number, End of Test	40.3	24.0	43.1	43.8	45.4
% Loss in Flow	20.7	51.3	12.6	12.2	6.6
Cat 1-H (AL-15482-F, Base)					
Flow Number, New	46.4	45.1	44.8	45.0	44.9
Flow Number, End of Test	38.3	23.7	41.1	40.9	40.3
% Loss in Flow	17.5	47.5	8.3	9.1	10.2
Average % Loss in Flow For Secondary Nozzle	19.1	49.4	10.5	10.7	8.4

\*Units of flow number are lbm/hr  $\sqrt{\text{psid}}$ . To convert to kg/s  $\sqrt{\text{kPa}}$ , multiply by  $4.80 \cdot 10^{-5}$ .

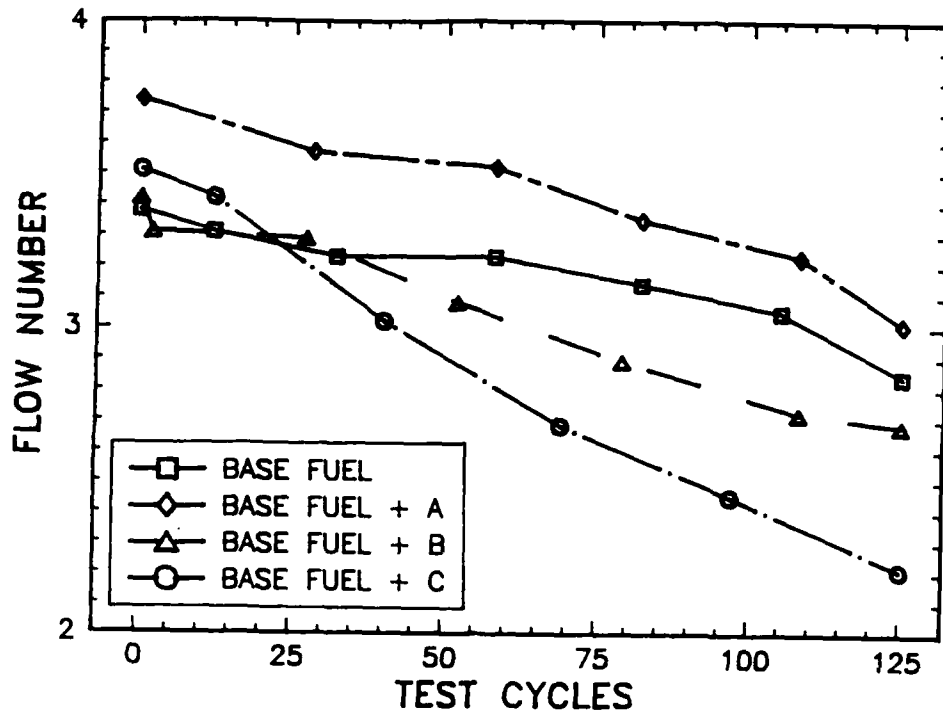

Figure 8. Degradation of flow capacity of primary fuel nozzles during 125-cycle test

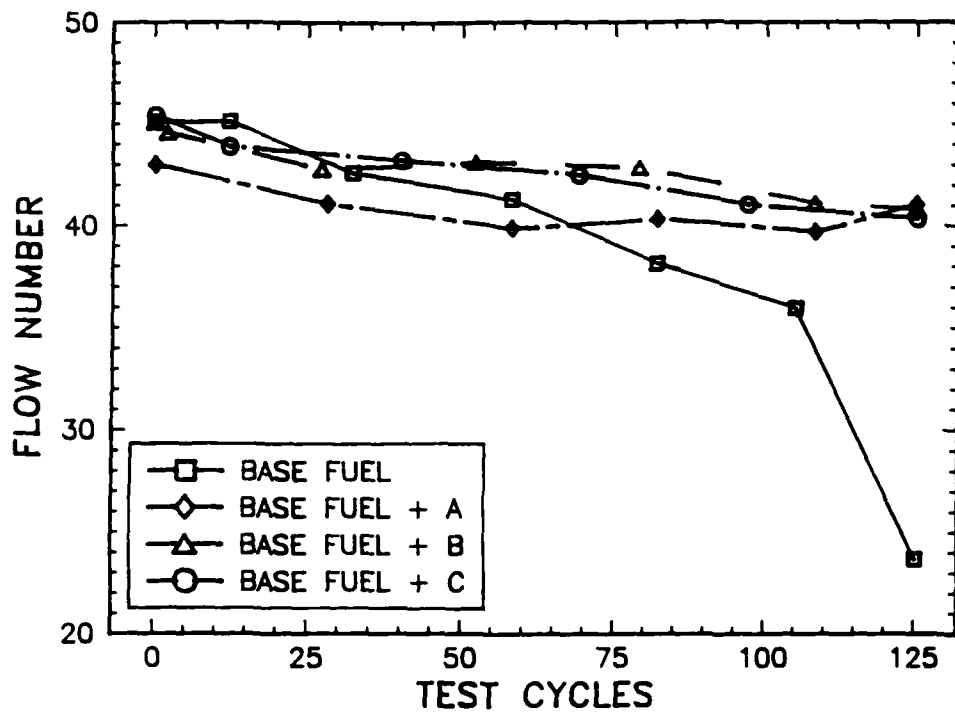

Figure 9. Degradation of flow capacity of secondary fuel nozzles during 125-cycle test

**TABLE 9. Relative Comparison of Fouling Tendencies of Base Fuel and Fuel With Additives**

Relative Additive Perf.	AGT-1500		Oxidation Stab. D 2274	JFTOT (D 3241)			
	Primary	Secondary		Filter $\Delta P$	TDR Visual Rating	Spun Rating	DMD
	Best	Base, A*		C	B	A,B	A,B
Second	Base, A	A,B	A	A,B	A,B	Base, B,C	C
Third	B	A,B	C	C	Base,C	Base, B,C	B
Worst	C	Base	Base	Base	Base,C	Base, B,C	Base

\*Where two or more values are reported, results were essentially equivalent within precision of test

relative to the base fuel for the TDR rating of D 3241 and the DMD test. However, at 260°C, the fuel with Additive B (17368) showed very significant improvement over the base fuel. The three fuels with Additives A, B, and C showed a significant improvement in performance for the secondary nozzles of the AGT-1500, but no improvement for the primary. For the fuels with Additives A and B, the flow degradation of the primary nozzle was similar to the base fuel, while the fuel with Additive C was worse than the base fuel. This difference between the fuel additive effects on fouling in the primary and secondary nozzles is apparently due to differences in the deposit-formation process in the two nozzles.

Additives A and B appeared to significantly reduce fouling in the secondary nozzles without significant impact on fouling in the primary nozzles. For ignition processes, flow through the primary nozzle is more important than flow through the secondary nozzle, so the use of these additives may offer better overall performance but little or no improvement in ignition.

Because the 125-cycle tests using the AGT-1500 combustor are expensive, only one test with each fuel was performed. Therefore, the repeatability of the overall test is unknown. However, the repeatability of the flow number measurement was evaluated by

independent measurements performed on different days for the new atomizers. Based on those tests, the average difference between flow number readings on different days was 1.0 percent for the primary nozzles and 2.9 percent for the secondary nozzles.

It would be advantageous to predict the fouling tendencies of fuels with additives for the AGT-1500 fuel nozzles without performing full-scale combustor tests. Bench-scale tests are much less expensive than full-scale tests, and for that reason the results of the full-scale tests are compared with those of various bench-scale tests in TABLE 9. The bench-scale tests generally show an improvement in fouling performance for the additive-treated fuels relative to the baseline fuel, while the results for the primary nozzle of the AGT-1500 engine show no improvement with the additives. The secondary nozzle of the AGT-1500 shows a significant improvement with the use of additives, although the ordering is different from any of the bench-scale tests. Since fouling of the AGT-1500 primary nozzle is of greater concern than the secondary for the ignition problem, the results shown in TABLE 9 do not identify a standard bench-scale test that can be used in place of the full-scale tests.

Because of the failure of standard bench-scale tests to correlate with the fouling results in the AGT-1500 primary nozzles, a set of tests was performed with the Phillips microburner for comparison with full-scale test results. However, before reporting the microburner test results, the results of spray tests with the fouled AGT-1500 atomizers are reported.

Fuel nozzle fouling affects not only the flow rate through the atomizer, but also the spray quality. To evaluate the degradation of spray quality caused by fouling, each of the primary atomizers was tested for average drop size produced at a fixed pressure differential of 1034 kPa (150 psid). These average drop sizes, as represented by the Sauter mean diameters, are given in TABLE 10.

As shown in TABLE 10, the degradation in flow capacity of nozzles 4, 6, and 7 was significant relative to the new (unfouled) nozzle 8, but the spray was not degraded except for nozzle 6. These results suggest that fouling in nozzles 4 and 7 was probably in the fuel-feed slots that allow fuel to enter the swirl chamber, while nozzle 6 may have had fouling in the swirl chamber or at the nozzle tip. Fouling in the fuel-feed slots may affect the symmetry of the fuel distribution in the spray. The ignition process is known

**TABLE 10. Spray Test Results with Fouled AGT-1500 Primary Atomizers**

Sauter mean diameters measured as integral line-of-sight values through spray centerline, 70 mm downstream of tip, 1034 kPa (150 psid), MIL-C-7024, Type II calibration fluid

Nozzle No.	3	4	5	6	7	8
Test Fuel	"Clean" Cat 1-H	Base Cat 1-H	Base +A	Base +B	Base +C	New Nozzle
Test Fuel AL No.	15706	15482	17369	17368	17499	--
Fuel Flow Rate at 1034 kPa (150 psid), g/s	4.8	4.2	Not available	4.0	2.9	4.8
Flow Number, lbm/hr $\sqrt{\text{psid}}$ *	3.09	2.89	--	2.60	1.86	3.09
Average Drop Size, Sauter mean diameter, $\mu\text{m}$	34.4	33.1	--	46.5	32.1	32.3
Std. Deviation of Sauter mean diameter, $\mu\text{m}$	0.35	0.78	--	0.88	0.74	1.7

\* To convert to kg/s  $\sqrt{\text{kPa}}$ , multiply by  $4.80 \cdot 10^{-5}$

to depend strongly on the average drop size produced (6), and can also depend on the spray shape and fuel distribution. Fuel flow rates in TABLE 10 are slightly different from those in TABLE 8 because several months elapsed between the tests, and nozzle handling may have affected the deposits.

**B. Microburner Test Results**

Two sets of tests were performed with the Phillips microburner. The first set of tests was performed with different levels of a stabilizer Additive C, approved under MIL-S-53021. The second set of tests was performed with different levels of three other additives not approved under MIL-S-53021, but which have been effective at reducing deposits under some conditions. Results for these two sets of microburner tests are described below, starting with the results of Additive C.

Nine microburner tests were conducted using an Cat 1-H fuel (AL-15706-F), the Cat 1-H plus Additive C at the rate of 11.3 kg/1000 bbl (71 mg/L), and the Cat 1-H plus

Additive C at the rate of 34.0 kg/1000 bbl (214 mg/L). The average results from this work show that the inside tube deposits slightly increased with increased stabilizer additive (Fig. 10). The results also show that, as the stabilizer additive concentration increased, the outside tube deposits decreased. Both the outside and inside tube deposits decreased or increased directly proportional to the additive concentration. The test repeatability using the stabilizer Additive C does not appear to be as good as with the neat Cat 1-H fuel.

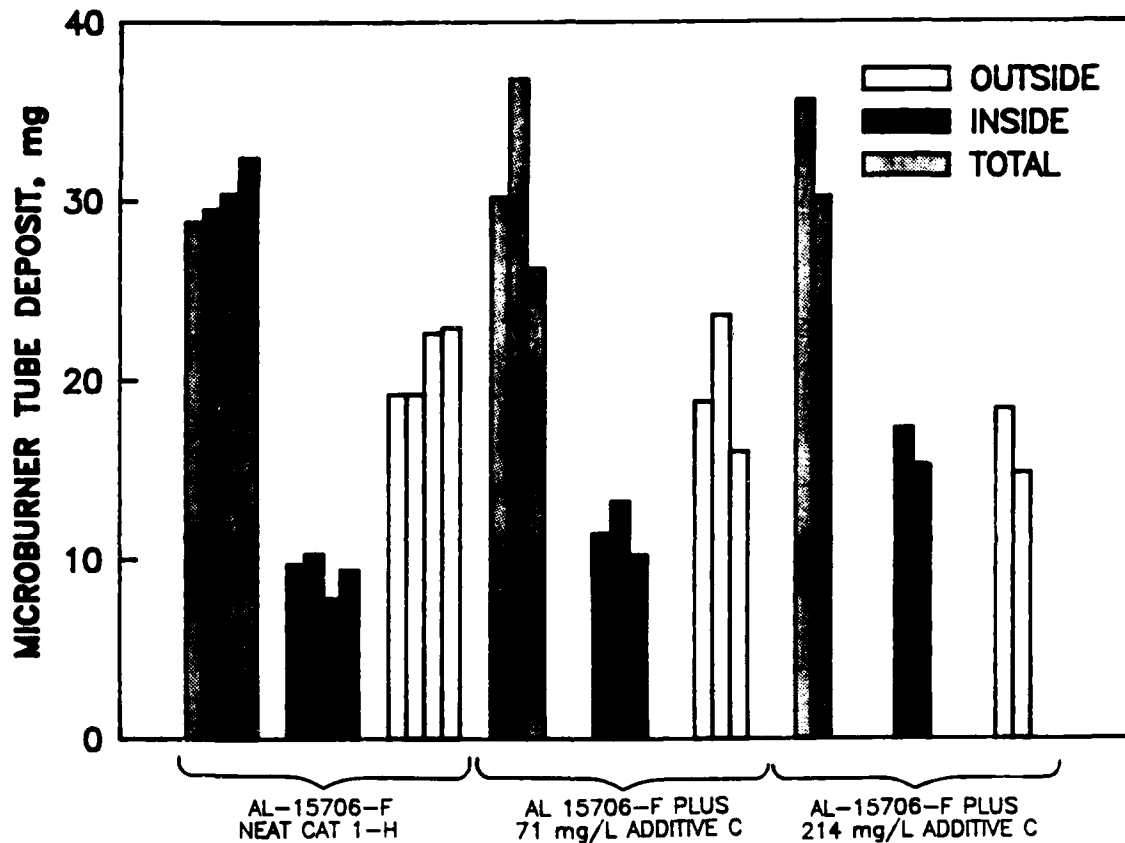

**Figure 10. Comparison of microburner tube deposits with additive C**

Three additives (not approved under MIL-S-53021) noted in TABLE 11 were also chosen for evaluation based on a recent publication showing them to be effective in reducing combustion-related deposits in diesel engines. These three additives were used at different concentrations to form seven blends as shown in TABLE 11.

The seven blends (except for 5 and 6) in TABLE 11 were tested in duplicate, and their average results are illustrated in Fig. 11. Blends 5 and 6 were not run in duplicate due to very high inside deposits. When comparing outside tube deposits (soot) for these seven

**TABLE 11. Blends Evaluated With Microburner**

<u>Blend No.</u>	<u>Fuel, Cat I-H Plus</u>
3	180 mg/L Additive A
4	360 mg/L Additive A
5	1458 mg/L Additive D
6	3025 mg/L Additive D
7	1751 mg/L Additive B
8	4380 mg/L Additive B
9	8757 mg/L Additive B

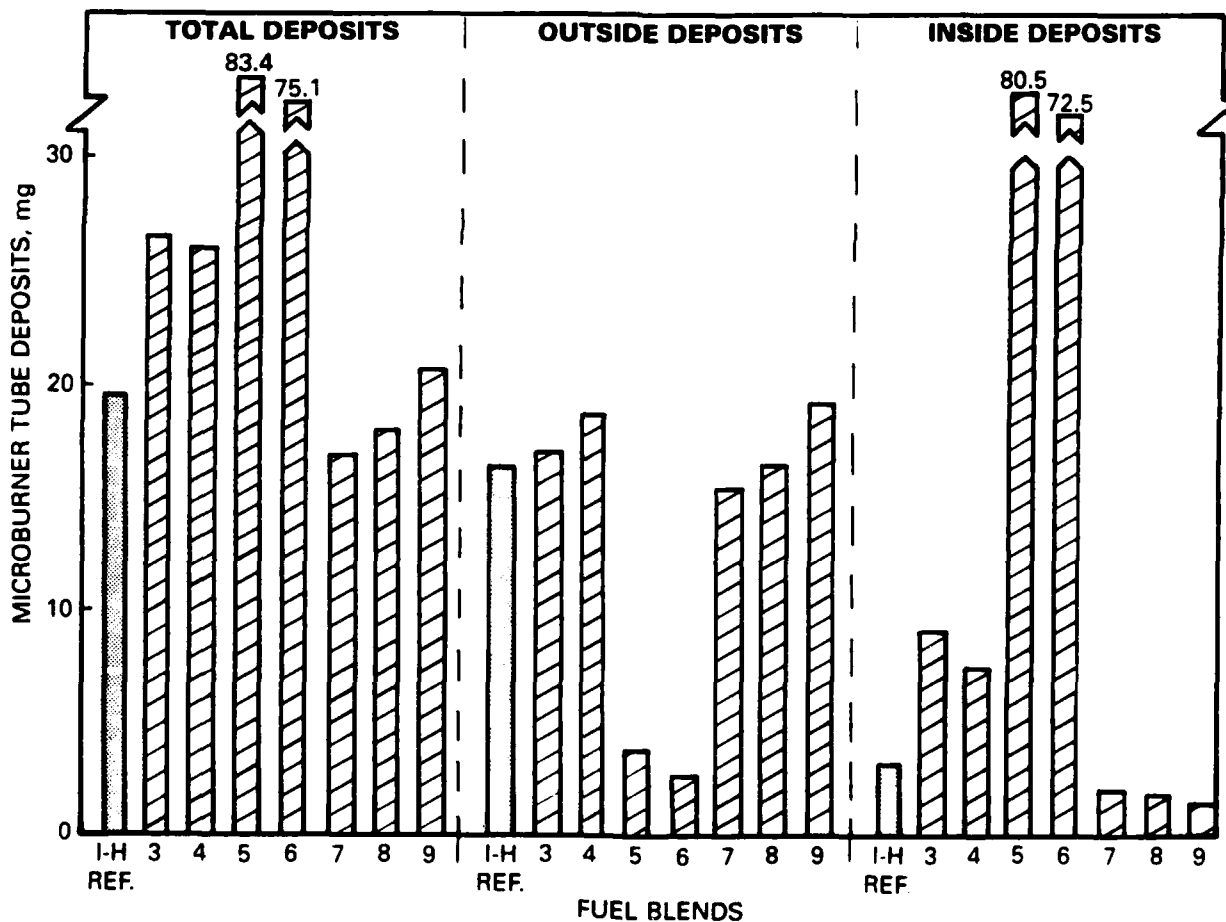

**Figure 11. Comparison of microburner tube deposits with additives A, B, and D**

blends to those of the Cat 1-H base fuel, blends 5, 6, and 7 had less deposits; blends 3, 4, and 9 had increased outside deposits (soot); and blend 8 had approximately the same results. When comparing the inside lacquer-type deposits to the Cat 1-H base fuel, only blends 7 through 9 showed any effect in reducing deposition, which is of particular interest if these results relate to the AGT-1500 nozzle and diesel injector fouling tendencies. Note in Fig. 11 the dramatic reduction in outside deposits (soot) for blends 5 and 6 compared to Cat 1-H. The reduction is due to the smoke suppressant used in the additive package for blends 5 and 6.

Additive B was judged most effective in reducing internal deposits in the microburner tests. If these microburner results were to correspond to internal AGT-1500 nozzle deposits, then stabilizer Additive C should have no beneficial effects while Additive B should reduce deposition compared with the neat fuel.

However, the results previously discussed and shown in TABLE 8 indicate that fuels with both Additives B and C caused deposits in the primary nozzle that were greater than the base fuel. Thus, the tests on the microburner do not correlate with the results from the full-scale AGT-1500 combustor tests.

### C. Solvents for Deposit Removal

A third objective of this program was to evaluate solvents and cleaners for removing the deposits on the nozzles. To carry out this objective, fouled, internal, single-piece AGT-1500 nozzle parts were obtained during a field trip to Fort Hood, TX. The nozzle parts were used in a comparative cleaning evaluation summarized in TABLE 12. Cleaning Solvent CS9 worked particularly well on parts placed in a sonic bath for 4- to 6-hour periods.

The nozzle set (No. 1) shown in Fig. 7 was used with Cat 1-H and Additive C-treated Cat 1-H (25 to 40 cycles) in the process of developing the 125-cycle tests. Both sonic bath cleaning with Solvent CS9 and pressure-flowing heated CS9 through both nozzles 1 and 2 were not completely effective in cleaning the internal nozzle chambers, as determined by flow tests. Nozzle 2 returned to initial rated flow after cleaning with hot pumped Solvent CS11 (containing 25 to 35 percent hydrochloric acid) but was visibly etched. Nozzle 1 was sectioned to reveal a complex tip in the primary nozzle (Fig. 12) and

**TABLE 12. Solvent Effectiveness for Cleaning Fouled  
AGT-1500 Nozzle Parts**

<u>Cleaning Solution No.</u>	<u>Cleaning Rating*</u>	<u>Comments</u>
CS1	1	Boiling point of 104°F (40°C), chlorinated solvents
CS2	6	Boiling point of 150°F (66°C), organic solvents
CS3	6	Boiling point of 248°F (120°C), contains organic solvents
CS4	6	Boiling point of 248°F (120°C), ethylene glycol monomethyl ether
CS5	5	Boiling point of 406°F (208°C), miscible with water and most organic solvents, biodegradable
CS6	4	Boiling point of 395°F (202°C), miscible with water, biodegradable
CS7	5	Boiling point of 212°F (100°C), contains 10 percent ethylene glycol monobutyl ether and 40 percent aliphatic petroleum distillate
CS8	8	Completely soluble in water, alkaline, biodegradable
CS9	8	Completely soluble in water, alkaline, biodegradable
CS10	8	Boiling point of 182°F (83°C), phosphoric acid content 60 to 70 percent, 2-butoxyethanol content, 15 to 25 percent
CS11	10	Boiling point of 182°F (83°C), hydrogen chloride content 25 to 35 percent

\* Scale 1-10, 10 is best.

complex channels and chambers in the secondary nozzle. The deposits did not dissolve in CS9 or CS10 (60 to 70 percent phosphoric acid and 15 to 25 percent 2-butoxyethanol) at

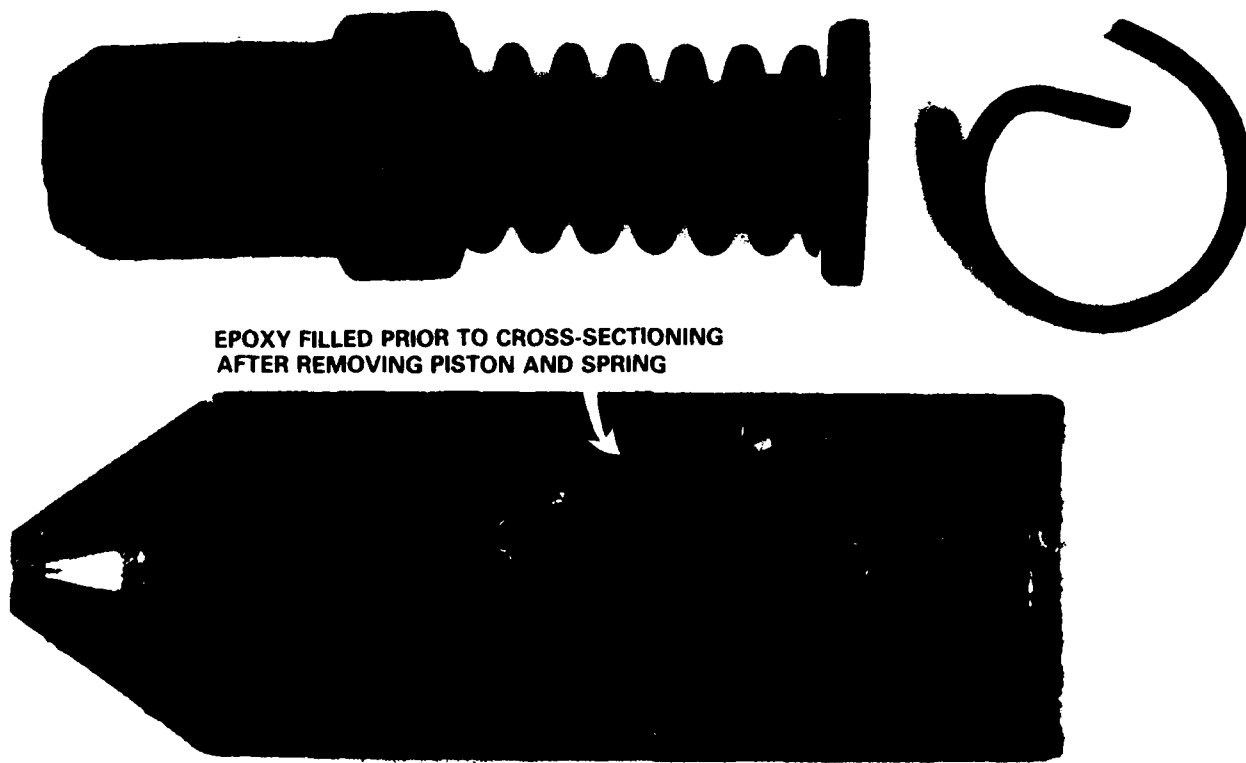

EPOXY FILLED PRIOR TO CROSS-SECTIONING  
AFTER REMOVING PISTON AND SPRING

**Figure 12. Sectioned tip of primary nozzle showing complex spring loaded internal piston with swirl channel**

room temperature as observed under a microscope. The deposits were carbonaceous in appearance. The nozzle manufacturer recommended Solvent CS10 as being the best solvent for cleaning the used nozzles.

Deposits from the sectioned nozzle were evaluated by Thermal Gravimetric Analysis (in air), which indicated that 500°C would be sufficient to "burn" the deposits. The nozzle manufacturer indicated that heating the nozzle at up to 927°C (1700°F) should present no problems if the elastometric O-ring was removed from the fuel connection.

Two approaches for cleaning the Nos. 3 through 7 nozzles were thus recommended for evaluation after completion of 125-cycles tests:

1. Circulate hot CS10 solvent (filtered)
2. Heat nozzles to 600°C (1100°F) with air flowing through the primary and secondary to accomplish carbon burn off followed by Solvent CS10 flushing.

## V. SUMMARY AND CONCLUSIONS

A 125-cycle AGT-1500 nozzle fouling test procedure has been established and used to evaluate diesel fuel (Cat 1-H) and four diesel fuel multifunctional additives. The test discriminates between fuels. Critical primary nozzle flow degradation was not significantly improved with the use of the additives tested to date. Phillips Microburner bench tests showed one of the additives to be effective in reducing internal tube lacquer deposits when compared to neat fuel. However, the microburner tests do not correlate with the full-scale AGT-1500 combustor tests.

Two nozzle cleaning procedures were identified but have yet to be evaluated.

## VI. RECOMMENDATIONS

The remaining nozzle Set No. 8 should be used to evaluate the JP-8 test fuel currently being used for power and performance testing at Ft. Bliss and M-3 endurance testing at Yuma Proving Grounds. It is anticipated the JP-8 will be thermally more stable than Cat 1-H.

The test nozzle Set Nos. 3 through 8 should then be evenly divided for clean up evaluation using the carbon burn-off/Solvent CS10 and hot (filtered) pumped CS10 as recommended procedures.

Consideration should be given to repeatability and higher cycle (250) operation to establish the AGT-1500 nozzle fouling test procedure.

## VII. LIST OF REFERENCES

1. Allen, T., Particle Size Measurement, Chapman and Hall, London, p. 128 (1981).
2. Dodge, L.G., "Representation of Average Drop Sizes in Sprays," to be published in AIAA Journal of Propulsion and Power, November/December 1988.

3. Streets, W.L., Phillips Microburner - A Tool for Evaluating the Burning Quality of Jet Fuels, Phillips Petroleum Company - Research Division Report 1793-57R Unit No. 42, Feature No. 2101, May 9, 1957.
4. Weatherford, W.D., Jr., Cuellar, J.P., Jr., and Johnston, R.K., "High Temperature Kinetics in Turbulent Combustor," Ind. Eng. Chem., 53, pp. 398-400, 1961.
5. U.S. Army Fuels and Lubricants Research Laboratory, Monthly Progress Report No. 14 for Period 1 April 1968-1 May 1968, prepared under contract DAAD05-67-C-0354 (Mod. P002), p. 45, May 1968.
6. Naegeli, D.W. and Dodge, L.G., "Effects of Fuel Properties and Atomization on Ignition in a T63 Gas Turbine Combustor," Interim Report BFLRF No. 235, prepared by Belvoir Fuels and Lubricants Research Facility (SwRI), December 1987.

## DISTRIBUTION LIST

### DEPARTMENT OF DEFENSE

DEFENSE TECHNICAL INFORMATION CTR  
CAMERON STATION 12  
ALEXANDRIA VA 22314

DEPT OF DEFENSE  
OASD/P&L  
ATTN: L/EP (MR DYCKMAN) 1  
WASHINGTON DC 20301-8000

CDR  
DEFENSE FUEL SUPPLY CTR  
ATTN: DFSC-Q (MR MARTIN) 1  
DFSC-DF (MR FRENCH) 1  
CAMERON STATION  
ALEXANDRIA VA 22304-6160

DOD  
ATTN: DUSDRE (RAT) (DR DIX) 1  
ROOM 3-D-1089, PENTAGON  
WASHINGTON DC 20301

DEFENSE ADVANCED RES PROJ AGENCY  
DEFENSE SCIENCES OFC 1  
1400 WILSON BLVD  
ARLINGTON VA 22209

### DEPARTMENT OF THE ARMY

CDR  
US ARMY BELVOIR RESEARCH,  
DEVELOPMENT & ENGINEERING CTR  
ATTN: STRBE-VF 10  
STRBE-BT 2  
FORT BELVOIR VA 22060-5606

HQ, DEPT OF ARMY  
ATTN: DALO-TSE (COL HOLLY) 1  
DALO-TSZ-B (MR KOWALCZYK) 1  
DALO-PLA (DR WILTSHIRE) 1  
SARD-TRS (DR CHURCH) 1  
SARD-TR (MS VANNUCCI) 1  
WASHINGTON DC 20310-0561

CDR  
US ARMY MATERIEL COMMAND  
ATTN: AMCDE-SS 1  
AMCSM-SP 1  
5001 EISENHOWER AVE  
ALEXANDRIA VA 22333-0001

CDR  
US ARMY COLD REGION TEST CENTER  
ATTN: STECR-TA 1  
APO SEATTLE 98733

CDR  
US ARMY TANK-AUTOMOTIVE COMMAND  
ATTN: AMSTA-RG (MR CHECKCLICK) 1  
AMSTA-TSL (MR BURG) 1  
AMSTA-MTC (MR GAGLIO) 1  
AMSTA-RGP (MR RAGGIO) 1  
AMSTA-MLF (MR KELLER) 1  
AMSTA-MC 1  
AMSTA-MV 1  
AMSTA-Z (MR FARKUS) 1  
WARREN MI 48397-5000

DIRECTOR  
US ARMY AVIATION RESEARCH &  
TECHNOLOGY ACTIVITIES (AVSCOM)  
ATTN: SAVRT-R (MR ANDRE) 1  
AMES RESEARCH CENTER  
(MAIL STOP 207-5)  
MOFFETT FIELD CA 94035-1099

DIRECTOR  
AVIATION APPLIED TECH DIR  
US ARMY R&T ACTIVITIES (AVSCOM)  
ATTN: SAVRT-TY-ATP (MR MORROW) 1  
FORT EUSTIS VA 23604-5577

PROJ MGR, MOBILE ELECTRIC POWER  
ATTN: AMCPM-MEP-TM 1  
(COL BRAMLETTE)  
7500 BACKLICK ROAD  
SPRINGFIELD VA 22150

CDR  
THEATER ARMY MATERIAL MGMT  
CENTER (200TH)-DPGM  
DIRECTORATE FOR PETROL MGMT  
ATTN: AEAGD-MMC-PT-Q 1  
APO NY 09052

CDR  
US ARMY GENERAL MATERIAL &  
PETROLEUM ACTIVITY  
ATTN: STRGP-F (MR ASHBROOK) 1  
STRGP-FE, BLDG 85-3  
(MR GARY SMITH) 1  
STRGP-FT (MR ROBERTS) 1  
NEW CUMBERLAND PA 17070-5008

CDR  
US ARMY LABORATORY COMMAND  
ATTN: AMSLC-AS-SE  
          AMSLC-TP-AL  
          (LTC SCHRADER)  
ADELPHI MD 20783-1145

CDR  
US ARMY RES & STDZN GROUP (UK)  
ATTN: AMXSN-UK-RA  
          (DR REICHENBACH)  
BOX 65  
FPO NEW YORK 09510-1500

CDR, US ARMY AVIATION SYSTEMS CMD  
ATTN: AMSAV-EP (MR EDWARDS)  
          AMSAV-NS  
4300 GOODFELLOW BLVD  
ST LOUIS MO 63120-1798

CDR  
US ARMY TANK-AUTOMOTIVE CMD  
PROGR EXEC OFF CLOSE COMBAT  
PM ABRAMS, ATTN: AMCPM-ABMS  
PM BFVS, ATTN: AMCPM-BFVS  
PM 113 FOV, ATTN: AMCPM-M113  
PM M60 FOV, ATTN: AMCPM-M60  
APEO SYSTEMS, ATTN: AMCPEO-CCU-S  
PM LAV, ATTN: AMCPM-LA-E  
WARREN MI 40397-5000

CDR  
US ARMY ABERDEEN PROVING GROUND  
ATTN: STEAP-MT-U  
ABERDEEN PROVING GROUND MD  
21005-5006

CDR  
US ARMY YUMA PROVING GROUND  
ATTN: STEYP-MT-TL-M  
          (MR DOEBBLER)  
YUMA AZ 85364-9103

CDR  
US ARMY TANK-AUTOMOTIVE CMD  
PROGR EXEC OFF COMBAT SUPPORT  
PM LIGHT TACTICAL VEHICLES  
ATTN: AMCPM-TVL  
PM MEDIUM TACTICAL VEHICLES  
ATTN: AMCPM-TVM  
PM HEAVY TACTICAL VEHICLES  
ATTN: AMCPM-TVH  
WARREN MI 40397-5000

CDR  
US ARMY RESEARCH OFFICE  
ATTN: SLCRO-EG (DR MANN)  
          SLCRO-CB  
P O BOX 12211  
RSCH TRIANGLE PARK NC 27709-2211

PROJ MGR, LIGHT ARMORED VEHICLES  
ATTN: AMCPM-LA-E  
WARREN MI 48397

CDR  
US ARMY DEVELOPMENT AND  
EMPLOYMENT AGENCY  
ATTN: MODE-FDD-CSSB  
FT LEWIS VA 98433-5000

CDR, US ARMY TROOP SUPPORT  
COMMAND  
ATTN: AMSTR-ME  
          AMSTR-S  
          AMSTR-E (MR CHRISTENSEN)  
          AMSTR-WL

4300 GOODFELLOW BLVD  
ST LOUIS MO 63120-1798

PROJ OFF, AMPHIBIOUS AND WATER  
CRAFT  
ATTN: AMCPM-AWC-R  
4300 GOODFELLOW BLVD  
ST LOUIS MO 63120-1798

CDR  
US ARMY LEA  
ATTN: DALO-LEP  
NEW CUMBERLAND ARMY DEPOT  
NEW CUMBERLAND PA 17070

HQ, EUROPEAN COMMAND  
ATTN: J4/7-LJPO (LTC WEINER)  
VAIHINGEN, GE  
APO NY 09128

CDR  
US ARMY EUROPE & SEVENTH ARMY  
ATTN: AEAGG-FMD  
          AEAGD-TE  
APO NEW YORK 09403

CDR  
US ARMY ENGINEER SCHOOL  
ATTN: ATSE-CD  
LEONARD WOOD MO 65473-5000

CDR  
US ARMY FOREIGN SCIENCE & TECH  
CENTER  
ATTN: AIAST-RA-ST3 (MR BUSI)  
FEDERAL BLDG  
CHARLOTTESVILLE VA 22901

CDR  
US ARMY GENERAL MATERIAL &  
PETROLEUM ACTIVITY  
ATTN: STRGP-PW  
BLDG 247, DEFENSE DEPOT TRACY  
TRACY CA 95376-5051

CDR  
US ARMY ORDNANCE CENTER &  
SCHOOL  
ATTN: ATSL-CD-CS  
ABERDEEN PROVING GROUND MD  
21005-5006

CDR  
AMC MATERIEL READINESS SUPPORT  
ACTIVITY (MRSA)  
ATTN: AMXMD-MO (MR BROWN)  
LEXINGTON KY 40511-5101

TRADOC LIAISON OFFICE  
ATTN: ATFE-LO-AV  
4300 GOODFELLOW BLVD  
ST LOUIS MO 63120-1798

HQ, US ARMY T&E COMMAND  
ATTN: AMSTE-CM-R-O  
AMSTE-TE-T (MR RITONDO)  
ABERDEEN PROVING GROUND MD  
21005-5006

CDR  
US ARMY TRANSPORTATION SCHOOL  
ATTN: ATSP-CD-MS  
FORT EUSTIS VA 23604-5000

CDR  
US ARMY NATICK RES & DEV CENTER  
ATTN: STRNC-U  
NATICK MA 01760-5020

PROJECT MANAGER  
PETROLEUM & WATER LOGISTICS  
ATTN: AMCPM-PWL  
4300 GOODFELLOW BLVD  
ST LOUIS MO 63120-1798

CDR  
US ARMY QUARTERMASTER SCHOOL  
ATTN: ATSM-CDM  
ATSM-TD  
ATSM-PFS (MR ELLIOTT)  
FORT LEE VA 23801

DIRECTOR  
US ARMY RSCH & TECH ACTIVITIES  
(AVSCOM)  
PROPULSION DIRECTORATE  
ATTN: SAVRT-PL-C (MR ACURIO)  
21000 BROOKPARK ROAD  
CLEVELAND OH 44135-3127

HQ, US ARMY ARMOR CENTER  
ATTN: ATSB-CD-ML  
ATSB-TSM-T (MAJ GROSS)  
FORT KNOX KY 40121

CDR  
US ARMY LOGISTICS CTR  
ATTN: ATCL-CD  
FORT LEE VA 23801-6000

CDR  
US ARMY FIELD ARTILLERY SCHOOL  
ATTN: ATSF-CD  
FORT SILL OK 73503-5600

CDR  
US ARMY INFANTRY SCHOOL  
ATTN: ATSH-CD-MS-M  
FORT BENNING GA 31905-5400

DIR  
US ARMY MATERIALS TECHNOLOGY  
LABORATORY  
ATTN: SLCMT-M  
SLCMT-MCM-P (DR FOPIANO)  
WATERTOWN MA 02172-2796

CDR  
US ARMY ARMOR & ENGINEER BOARD  
ATTN: ATZK-AE-AR  
FORT KNOX KY 40121

CDR  
US ARMY AVIATION CTR & FT RUCKER  
ATTN: ATZQ-DI  
FORT RUCKER AL 36362

**DEPARTMENT OF THE NAVY**

CDR  
NAVAL AIR PROPULSION CENTER  
ATTN: PE-33 (MR D'ORAZIO)  
P O BOX 7176  
TRENTON NJ 06828-0176

CDR  
NAVAL SEA SYSTEMS COMMAND  
ATTN: CODE 05M32  
WASHINGTON DC 20362-5101

CDR  
NAVAL AIR ENGR CENTER  
ATTN: CODE 92727  
LAKEHURST NJ 08733

CDR  
NAVAL SHIP SYS ENGINEERING CTR  
ATTN: CODE 053C  
PHILADELPHIA PA 19112-5083

JOINT OIL ANALYSIS PROGRAM -  
TECHNICAL SUPPORT CTR  
BLDG 780  
NAVAL AIR STATION  
PENSACOLA FL 32508-5300

CDR  
DAVID TAYLOR RESEARCH CTR  
ATTN: CODE 2759 (MR STRUCKO)  
CODE 2831  
ANNAPOLIS MD 21402-5067

PROJ MGR, M60 TANK DEVELOPMENT  
ATTN: USMC-LNO  
US ARMY TANK-AUTOMOTIVE  
COMMAND (TACOM)  
WARREN MI 48397-5000

DEPARTMENT OF THE NAVY  
HQ, US MARINE CORPS  
ATTN: LPP/2 (MAJ NICHOLS)  
LMM/2 (MAJ PATTERSON)  
LMW  
WASHINGTON DC 20380

CDR  
NAVAL AIR SYSTEMS COMMAND  
ATTN: CODE 53632F (MR MEARNES)  
WASHINGTON DC 20361-5360

CDR  
NAVAL RESEARCH LABORATORY  
ATTN: CODE 6170  
CODE 6180  
1 WASHINGTON DC 20375-5000

CDR  
NAVAL FACILITIES ENGR CTR  
ATTN: CODE 1202B (MR R BURRIS)  
200 STOVAL ST  
1 ALEXANDRIA VA 22322

COMMANDING GENERAL  
US MARINE CORPS DEVELOPMENT  
& EDUCATION COMMAND  
1 ATTN: DO741  
QUANTICO VA 22134

CDR  
NAVY PETROLEUM OFFICE  
ATTN: CODE 43 (MR LONG)  
CAMERON STATION  
1 ALEXANDRIA VA 22304-6180

1 OFFICE OF THE CHIEF OF NAVAL  
RESEARCH  
ATTN: OCNR-126 (DR ROBERTS)  
ARLINGTON VA 22217-5000

DEPUTY CG  
USMC RDEA COMMAND  
ATTN: CBAT (LTC KEPHART)  
1 QUANTICO VA 22134

**DEPARTMENT OF THE AIR FORCE**

HQ, USAF  
ATTN: LEYSF  
1 WASHINGTON DC 20330

CDR  
US AIR FORCE WRIGHT AERO LAB  
ATTN: AFWAL/POSF (MR DELANEY)  
1 WRIGHT-PATTERSON AFB OH  
1 45433-6563

CDR  
SAN ANTONIO AIR LOGISTICS CTR  
ATTN: SAALC/SFT (MR MAKRIS)  
SAALC/MMPRR  
1 KELLY AIR FORCE BASE TX 78241

CDR  
DET 29  
ATTN: SA-ALC/SFM  
CAMERON STATION  
ALEXANDRIA VA 22304-6179

HQ AIR FORCE SYSTEMS COMMAND  
ATTN: AFSC/DLF (DR DUES)  
ANDREWS AFB MD 20334

CDR  
WARNER ROBINS AIR LOGISTIC CTR  
ATTN: WRALC/MMTV (MR GRAHAM)  
ROBINS AFB GA 31098

**OTHER GOVERNMENT AGENCIES**

NATIONAL AERONAUTICS AND SPACE  
ADMINISTRATION  
LEWIS RESEARCH CENTER  
CLEVELAND OH 44135

1 ENVIRONMENTAL PROTECTION AGENCY  
AIR POLLUTION CONTROL 1  
2565 PLYMOUTH ROAD  
ANN ARBOR MI 48105

1 US DEPARTMENT OF ENERGY  
ATTN: MR ECKLUND 1  
MAIL CODE CE-151  
FORRESTAL BLDG.  
1000 INDEPENDENCE AVE, SW  
WASHINGTON DC 20585

1 DEPARTMENT OF TRANSPORTATION  
FEDERAL AVIATION ADMINISTRATION  
ATTN: AWS-110 1  
800 INDEPENDENCE AVE, SW  
WASHINGTON DC 20590