

2

SECURITY CLASSIFICATION OF THIS PAGE

REPORT DOCUMENTATION PAGE

DTIC FILE COPY

1a. REPORT NA		1b. RESTRICTIVE MARKINGS NA	
2a. SECURIT NA		3. DISTRIBUTION / AVAILABILITY OF REPORT Distribution Unlimited; Approved for Public Release	
2b. DECLAS NA		5. MONITORING ORGANIZATION REPORT NUMBER(S) NA	
4. PERFORMING ORGANIZATION REPORT NUMBER(S) AD-A203 490		7a. NAME OF MONITORING ORGANIZATION ONR	
6a. NAME OF PERFORMING ORGANIZATION Indiana University	6b. OFFICE SYMBOL (if applicable) NA	7b. ADDRESS (City, State, and ZIP Code) 800 N. Quincy Street Arlington, VA 22217	
6c. ADDRESS (City, State, and ZIP Code) Department of Chemistry Bloomington, IN 47405		9. PROCUREMENT INSTRUMENT IDENTIFICATION NUMBER Contract N00014-86-K-0366	
8a. NAME OF FUNDING / SPONSORING ORGANIZATION	8b. OFFICE SYMBOL (if applicable)	10. SOURCE OF FUNDING NUMBERS	
8c. ADDRESS (City, State, and ZIP Code)		PROGRAM ELEMENT NO.	PROJECT NO.
		TASK NO.	R&T Code
			4134006
11. TITLE (Include Security Classification) Convenient Fiber-Optic-Based Sample Cell for Shpol'skii and Low-Temperature Phosphorescence Spectrometry			
12. PERSONAL AUTHOR(S) Richard T. Madison, Mary K. Carroll, Gary M. Hieftje			
13a. TYPE OF REPORT Technical	13b. TIME COVERED FROM TO	14. DATE OF REPORT (Year, Month, Day) 28 October 1988	15. PAGE COUNT 14
16. SUPPLEMENTARY NOTATION Applied Spectroscopy			
17. COSATI CODES		18. SUBJECT TERMS (Continue on reverse if necessary and identify by block number)	
FIELD	GROUP	SUB-GROUP	
		Sensors, Optical Fibers, Shpol'skii Spectrometry, Phosphorimetry. (mgm) ←	
19. ABSTRACT (Continue on reverse if necessary and identify by block number)			
<p>A sample cell for observing the Shpol'skii effect at 77 K is described and analytically assessed. The cell employs fiber-optic light guides to transport excitation and emission radiation. The system is compact, inexpensive, simple to construct from commercially available laboratory components, and alleviates several problems inherent in conventional refrigerated-cell designs. Detection limits for anthracene, coronene, and pyrene obtained with the sample cell are $8.8 \times 10^{-8}M$, $8.4 \times 10^{-7}M$, and $3.5 \times 10^{-7}M$, respectively. The linear dynamic range for each compound is 2 to 3 orders of magnitude.</p>			
20. DISTRIBUTION / AVAILABILITY OF ABSTRACT <input checked="" type="checkbox"/> UNCLASSIFIED/UNLIMITED <input type="checkbox"/> SAME AS RPT <input type="checkbox"/> DTIC USERS		21. ABSTRACT SECURITY CLASSIFICATION Distribution Unlimited	
22a. NAME OF RESPONSIBLE INDIVIDUAL Gary M. Hieftje		22b. TELEPHONE (Include Area Code) (812) 335-2189	22c. OFFICE SYMBOL E

DTIC ELECTED
24 JAN 1989

10 to the -7th

10 to the -8th

CONVENIENT FIBER-OPTIC-BASED SAMPLE CELL FOR SHPOL'SKII
AND LOW-TEMPERATURE PHOSPHORESCENCE SPECTROMETRY

Richard T. Madison, Mary K. Carroll, Gary M. Hieftje*

Department of Chemistry
Indiana University
Bloomington, IN 47405

Accession For	
NTIS GRA&I	<input checked="" type="checkbox"/>
DTIC TAB	<input type="checkbox"/>
Unannounced	<input type="checkbox"/>
Justification	
By _____	
Distribution/	
Availability Codes	
Dist	Avail and/or Special
A-1	



ABSTRACT

A sample cell for observing the Shpol'skii effect at 77 K is described and analytically assessed. The cell employs fiber-optic light guides to transport excitation and emission radiation. The system is compact, inexpensive, simple to construct from commercially available laboratory components, and alleviates several problems inherent in conventional refrigerated-cell designs. Detection limits for anthracene, coronene, and pyrene obtained with the sample cell are $8.8 \times 10^{-8}M$, $8.4 \times 10^{-7}M$, and $3.5 \times 10^{-7}M$, respectively. The linear dynamic range for each compound is 2 to 3 orders of magnitude.

INTRODUCTION

It has long been known that certain aromatic compounds dissolved in a suitable n-alkane solvent can be cooled to 77 K and will produce "quasi-linear" excitation and emission spectra¹. This "shpol'skii" effect, so named in tribute to its discoverer, has become a widely used technique for the analysis of complex mixtures of polycyclic aromatic hydrocarbons (PAHs) and other compounds.

The most powerful application of the Shpol'skii effect as a qualitative tool lies in the ability to selectively excite individual components of a complex mixture of PAHs without pre-separation. For example, Gaevaya and co-workers showed that individual PAHs could be determined in a mixture of 15 PAHs with little pre-treatment². This capability has been demonstrated by use of conventional excitation sources³, as well as with a tunable dye laser^{4,5}.

When several instrumental and theoretical shortcomings are addressed⁶, Shpol'skii spectrometry becomes an attractive method for quantitative analysis also⁷. Analytical figures of merit for the Shpol'skii technique have been published^{8,9} and a comprehensive review of its application in analytical spectrometry has appeared¹⁰.

Because a sample must be cooled to cryogenic temperatures in Shpol'skii spectrometry, the sample-handling system is critical. Ordinarily a sample solution is immersed into a special Dewar-based cell filled with liquid nitrogen¹¹ or is cooled directly with a closed-cycle cryogenerator^{12,13}. However, both methods have shortcomings. A Dewar cell filled with liquid nitrogen suffers from interferences caused by bubbles liberated from the boiling nitrogen as well as from condensation of atmospheric gases on the sample cell. To remedy the problem of condensing atmospheric gases, a

heating element must be placed around the sample cell and dry nitrogen blown onto its face. Also, in some designs of this type, the entire sample cell must be frozen and rethawed before each new determination. In comparison, closed-cycle cryogenerators suffer from cost and the awkwardness and bulk of their vacuum systems.

The objective of the present investigation was to develop a sample cell which would eliminate the above shortcomings and, in so doing, make Shpol'skii spectrometry much simpler and more attractive. The new sample cell employs fiber optics and relatively conventional sample vials and allows simple and rapid analyses of samples with sensitivity comparable to that of conventional Shpol'skii spectrometry. Submicromolar detection limits can be obtained even on mixtures of PAHs, and the dynamic range for an individual PAH extends over two to three orders of magnitude.

EXPERIMENTAL

Apparatus. The sample cell was constructed from commercially available components (Figure 1). Seven (1 excitation, 6 emission), 600 μ M fused-silica fiber-optic cables (Galileo Electro-optics Corp., Sturbridge, MA) were epoxied (EpoTek, Epoxy Technology, Inc., Billerica, MA) into a nine-cm-long, 2.9-mm i.d. quartz tube which had a quartz window fused onto its end. The quartz tube was then inserted and secured through a hole drilled into the cap of a plastic microcentrifuge vial (Sarstedt, W. Germany). The range of sample volumes usable with this cell is approximately 0.25 to 1 ml.

A block diagram of the spectrometric system employed in these studies is given in Figure 2. An argon-ion laser (Spectra-Physics model 171) was

used in the multi-line UV mode at a current of 37 amps and a radiant power output of 200 mW. A bandpass filter (Melles Griot, Irvine, CA) was placed between the laser and the fiber-optic probe to isolate the most intense laser line which occurs at 363.8 nm. The laser light was focused onto the excitation fiber of the probe and the subsequent fluorescence was focused into a double monochromator (Model 1680A, Spex Industries, Inc., Metuchen, NJ) and detected by an RCA R928 photomultiplier tube (PMT) at -1000 volts. The PMT current was sent to a strip-chart recorder (Heath Model SR-204, Benton Harbor, MI) via a picoammeter (Kiethley Instruments, Model 414S, Cleveland, OH).

Reagents. The PAH analytes were selected for study according to their relatively low toxicity, highly fluorescent nature, and low cost. All PAHs were purchased in the purest form commercially available and were not purified further. The PAHs chosen were: anthracene (Aldrich, Cincinnati, OH; Gold Label, 99.9%), pyrene (Aldrich, 99+%), and coronene (Aldrich, 99%).

The Shpol'skii solvent was n-heptane (Mallinckrodt, Paris, KY, Spectroscopic Grade), suitable for the dimensions of the PAHs used in these experiments. The n-heptane was used as received, without further purification.

Procedure. Sample solutions were placed into the disposable centrifuge vials and each vial secured onto the screw-cap probe top. The entire sample cell was then immersed into an open-ended conventional Dewar flask which was filled with approximately 100 ml of liquid nitrogen. The cell was then allowed to cool for 4 minutes to ensure complete freezing (n-heptane freezes into a snow rather than a glass). The frozen sample was then irradiated and the selected fluorescence wavelength range scanned with a monochromator bandpass of 0.5 nm. At the completion of each scan, the sample cell was

removed from the Dewar and allowed to thaw. The entire analysis time was approximately 10 minutes per sample.

RESULTS AND DISCUSSION

Shpol'skii Spectra. The quasi-linear fluorescence spectrum of anthracene obtained through use of the new fiber-optic probe is shown in Figure 3. The full width at half maximum (FWHM) of the 403 nm band in the anthracene spectrum was measured to be 1.3 nm. Similarly, Figure 4 shows the quasi-linear fluorescence spectrum of coronene. The FWHM of the 447 nm band in this spectrum is 0.6 nm. Finally, the quasi-linear spectrum of pyrene can be seen in Figure 5. The 393 nm band of this spectrum has a FWHM of 0.8 nm.

Phosphorescence spectra. The fiber-optic Shpol'skii probe can be used for phosphorescence measurements in the same manner and using the same spectrometric system. As an example, Figure 6 shows the low-temperature (77 K) phosphorescence spectrum of coronene in n-heptane.

Analytical Figures of Merit. Analytical curves for the Shpol'skii fluorescence of anthracene, coronene, and pyrene are displayed in Figure 7. The wavelength which gave the greatest signal in each individual fluorescence spectrum was used for the calibration curve for that PAH. The limit of detection and linear dynamic range of each PAH was governed by the strong, scattered laser light from the frozen sample matrix.

The limits of detection for anthracene, coronene, and pyrene were determined to be 8.8×10^{-8} M, 8.4×10^{-7} M, and 3.5×10^{-7} M, respectively. The detection limit was taken as the concentration of PAH giving a signal-to-noise ratio of 3. The limits of detection obtained with the new fiber-optic cell compare well with those reported for a conventional Shpol'skii

apparatus 8,9.

The usable dynamic range for each PAH is two to three orders of magnitude. The lowest concentration value plotted on each analytical curve is the limit of detection. The relative standard deviations for seven replicate measurements on each fluorophore at a concentration roughly in the center of the respective calibration curve were: anthracene, 6.8%; coronene, 13%; and pyrene, 15%.

CONCLUSIONS

The fiber-optic sample cell has been shown to be useful for obtaining fluorescence and phosphorescence spectra of PAHs in Shpol'skii matrices and has many advantages over conventional Shpol'skii sample cells. Because the fiber-optic strands are frozen directly within the sample matrix, the new cell overcomes problems caused by nitrogen bubbles and condensation of atmospheric gases. The cell is compact, inexpensive, and simple to construct from commercially available laboratory components. Finally, the analytical figures of merit for the Shpol'skii sample cell are comparable to those found in the literature for conventional Shpol'skii cells.

ACKNOWLEDGMENTS

Supported in part by the Office of Naval Research, by the National Science Foundation through grant CHE 97-22639 and by The Upjohn Co. Presented in part at the 1988 meeting of the Federation of Analytical Chemistry and Spectroscopy Societies.

1. Shpol'skii, E.V.; Il'ina, A.A.; Klimova, L.A., Dokl. Akad. Nauk. SSSR, 87, 935-940 (1952).
2. Gaevaya, T. Ya; Dhesina, A. Ya., J. Anal. Chem. (USSR), 29, 1913-1917 (1974).
3. Lavalette, D.; Muel, B.; Hubert-Habart, M.; Rene, L.; Laterjet, R., J. Chim. Phys., 65, 2144 (1968).
4. Yang, Y.; D'Silva, A.P.; Fassel, V.A., Anal. Chem., 53, 894-899 (1981).
5. D'Silva, A.P.; Fassel, V.A., Anal. Chem., 56, 985A-1000A (1984).
6. Lukasiewicz, R.J.; Winefordner, J.D., Talanta, 19, 381-382 (1971).
7. Kirkbright, G.F.; DeLima, C.G., Analyst (London), 99, 338-354 (1974).
8. Inman, E.L.; Jurgensen, A.; Winefordner, J.D., Analyst (London), 107, 538-543 (1982).
9. Lai, E.P.; Inman, E.L.; Winefordner, J.D., Talanta, 29, 601-608 (1982).
10. DeLima, C.G., CRC Crit. Rev. Anal. Chem., 16, 177-221 (1986).
11. Causey, B.S.; Kirkbright, G.F.; DeLima, C.G., Analyst (London), 101, 367-378 (1976).
12. Rima, J.; Lamotte, M.; Jousset-Dubien, J., Anal. Chem., 54, 1059 (1982).
13. Paturel, L.; Jarosz, F.; Fachinger, C.; Suptil, J., Anal. Chim. Acta, 147, 293-302 (1983).

Figure Captions

- Figure 1. Side view and end view of the fiber-optic Shpol'skii sample cell.
- Figure 2. Block diagram of spectrometric system.
- Figure 3. Quasi-linear fluorescence spectrum of anthracene in heptane at 77K.
- Figure 4. Quasi-linear fluorescence spectrum of coronene in heptane at 77K.
- Figure 5. Quasi-linear fluorescence spectrum of pyrene in heptane at 77K.
- Figure 6. Phosphorescence spectrum of coronene in heptane at 77K.
- Figure 7. Analytical calibration curves for PAHs in heptane at 77K.

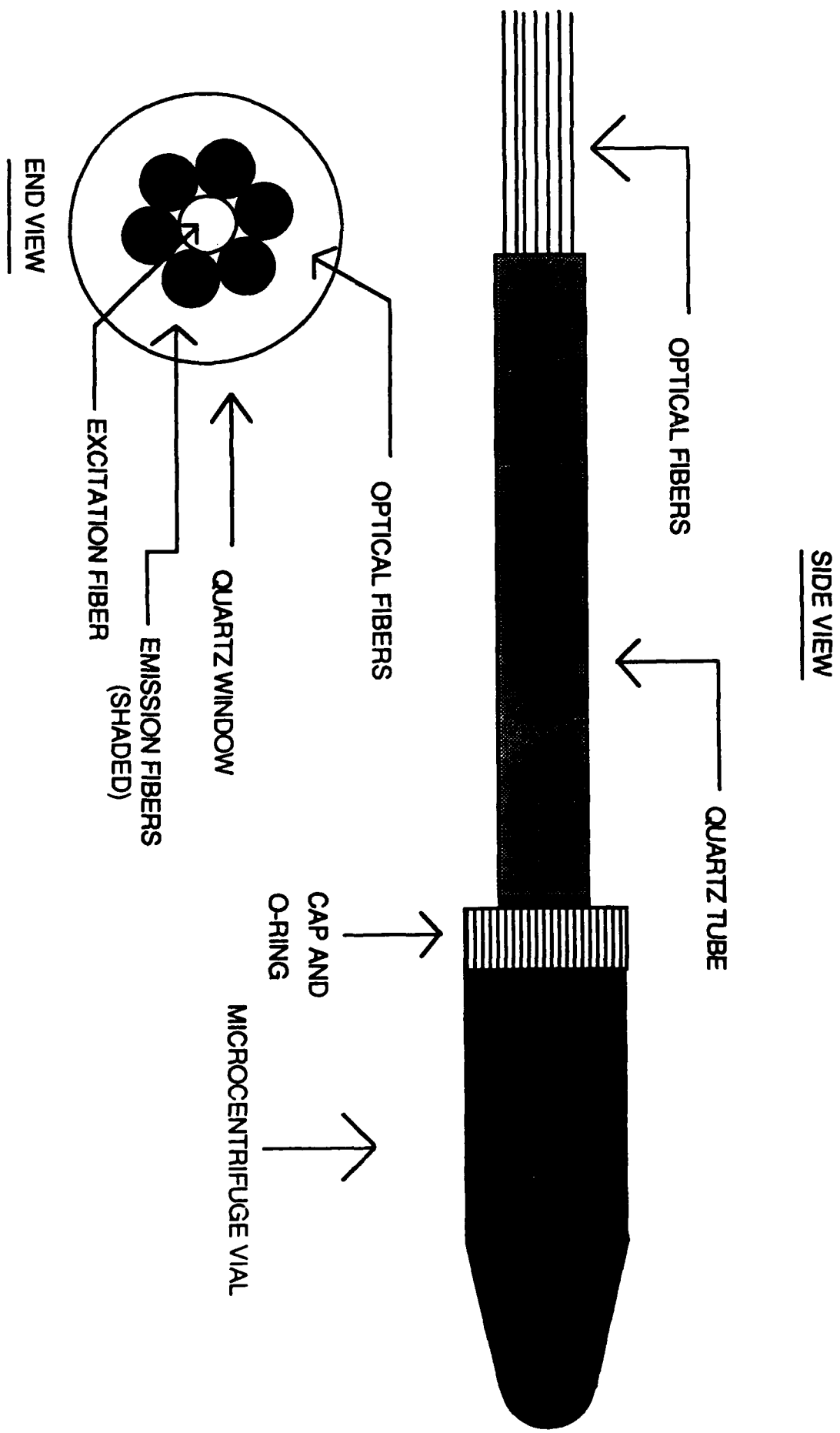
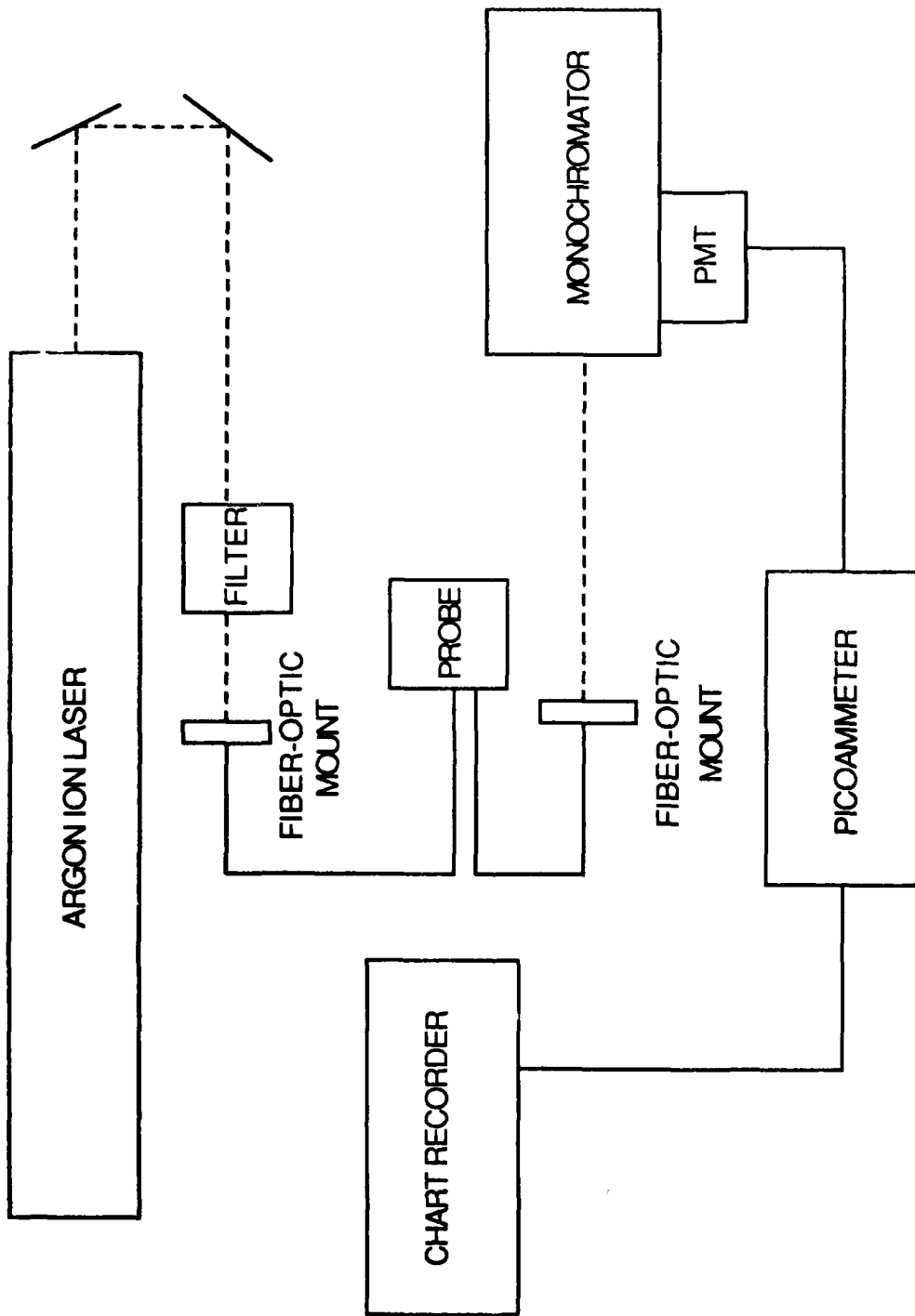
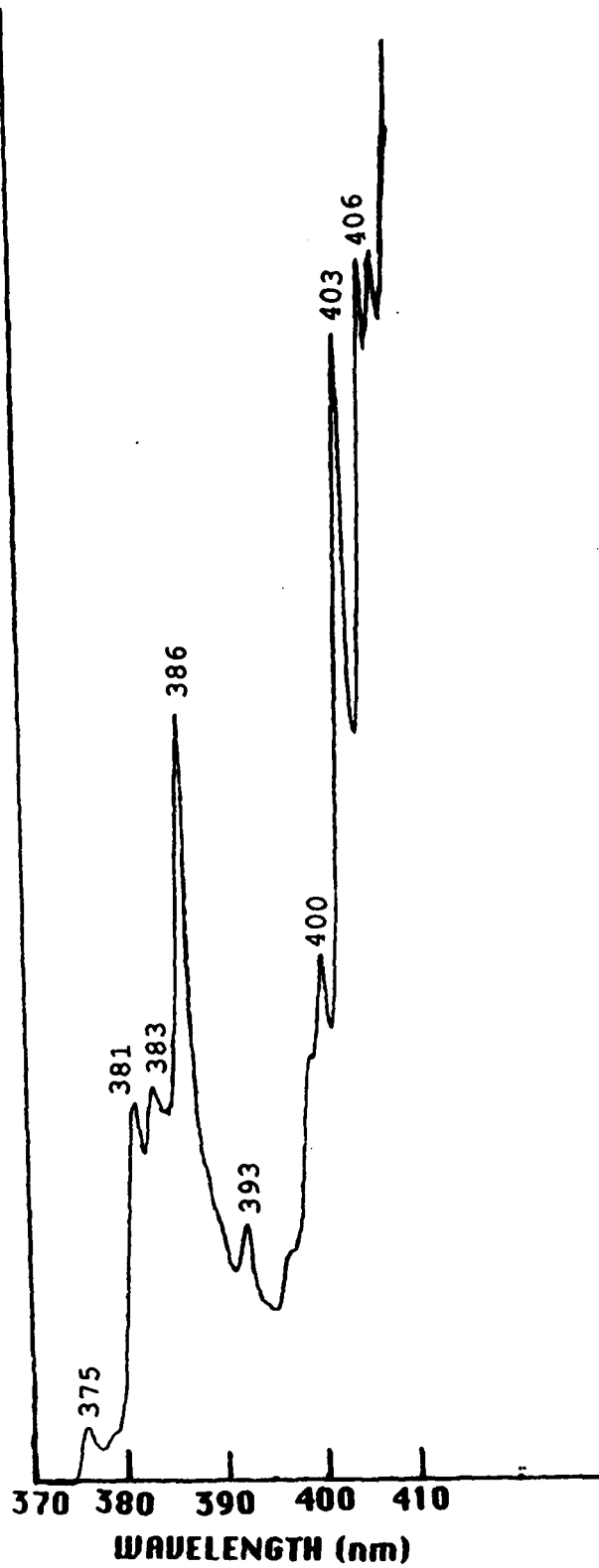

Fig 1



EMISSION INTENSITY (ARBITRARY UNITS)



EMISSION INTENSITY (ARBITRARY UNITS)

