

AD-A203 890

Copy 15 of 80 copies

2

AD-A203 890

IDA PAPER P-2093

ELECTROLYTIC PROTECTION AGAINST
HIGH-TEMPERATURE OXIDATION

Thomas F. Kearns

DTIC
SELECTED
FEB 07 1989
D Co

November 1988

Prepared for
Defense Advanced Research Projects Agency



INSTITUTE FOR DEFENSE ANALYSES
1801 N. Beauregard Street, Alexandria, Virginia 22311

89 2 6 070

IDA Log No. HQ 88-33190

DEFINITIONS

IDA publishes the following documents to report the results of its work.

Reports

Reports are the most authoritative and most carefully considered products IDA publishes. They normally embody results of major projects which (a) have a direct bearing on decisions affecting major programs, or (b) address issues of significant concern to the Executive Branch, the Congress and/or the public, or (c) address issues that have significant economic implications. IDA Reports are reviewed by outside panels of experts to ensure their high quality and relevance to the problems studied, and they are released by the President of IDA.

Papers

Papers normally address relatively restricted technical or policy issues. They communicate the results of special analyses, interim reports or phases of a task, ad hoc or quick reaction work. Papers are reviewed to ensure that they meet standards similar to those expected of refereed papers in professional journals.

Memorandum Reports

IDA Memorandum Reports are used for the convenience of the sponsors or the analysts to record substantive work done in quick reaction studies and major interactive technical support activities; to make available preliminary and tentative results of analyses or of working group and panel activities; to forward information that is essentially unanalyzed and unevaluated; or to make a record of conferences, meetings, or briefings, or of data developed in the course of an investigation. Review of Memorandum Reports is suited to their content and intended use.

The results of IDA work are also conveyed by briefings and informal memoranda to sponsors and others designated by the sponsors, when appropriate.

The work reported in this document was conducted under contract MDA 983 84 C 0031 for the Department of Defense. The publication of this IDA document does not indicate endorsement by the Department of Defense, nor should the contents be construed as reflecting the official position of that agency.

This Memorandum Report is published in order to make available the material it contains for the use and convenience of interested parties. The material has not necessarily been completely evaluated and analyzed, nor subjected to IDA review.

Approved for public release; distribution unlimited.

UNCLASSIFIED

SECURITY CLASSIFICATION OF THIS PAGE

REPORT DOCUMENTATION PAGE

1a. REPORT SECURITY CLASSIFICATION UNCLASSIFIED		1b. RESTRICTIVE MARKINGS	
2a. SECURITY CLASSIFICATION AUTHORITY N/A		3. DISTRIBUTION/AVAILABILITY OF REPORT Approved for public release; distribution unlimited.	
2b. DECLASSIFICATION/DOWNGRADING SCHEDULE N/A			
4. PERFORMING ORGANIZATION REPORT NUMBER(S) IDA Paper P-2093		5. MONITORING ORGANIZATION REPORT NUMBER(S)	
6a. NAME OF PERFORMING ORGANIZATION Institute for Defense Analyses	6b. OFFICE SYMBOL (If applicable)	7a. NAME OF MONITORING ORGANIZATION	
6c. ADDRESS (City, State, and Zip Code) 1801 N. Beauregard Street Alexandria, VA 22311		7b. ADDRESS (CITY, STATE, AND ZIP CODE)	
8a. NAME OF FUNDING/SPONSORING ORGANIZATION Defense Advanced Research Projects Agency	8b. OFFICE SYMBOL (If applicable)	9. PROCUREMENT INSTRUMENT IDENTIFICATION NUMBER MDA 903 84 C 0031	
8c. ADDRESS (City, State, and Zip Code) 1400 Wilson Boulevard Arlington, VA 22209-2308		10. SOURCE OF FUNDING NUMBERS	
		PROGRAM ELEMENT	PROJECT NO.
			TASK NO. A-86
			WORK UNIT ACCESSION NO.
11. TITLE (Include Security Classification) Electrolytic Protection Against High-Temperature Oxidation			
12. PERSONAL AUTHOR(S) Thomas F. Kearns			
13. TYPE OF REPORT Final	13b. TIME COVERED FROM 2/87 TO 2/88	14. DATE OF REPORT (Year, Month, Day) November 1988	15. PAGE COUNT 40
16. SUPPLEMENTARY NOTATION			
17. COSATI CODES		18. SUBJECT TERMS (Continue on reverse if necessary and identify by block number)	
FIELD	GROUP	SUB-GROUP	
19. ABSTRACT (Continue on reverse if necessary and identify by block number)			
<p>This paper describes and discusses protection of materials against high-temperature oxidation achieved by coating their surfaces with a solid electrolyte and making the substrate cathodic in an electrolytic cell created by a potential applied across the electrolyte. This approach, similar in nature to the widely followed practice of cathodic protection against aqueous corrosion, is shown to be theoretically sound and potentially advantageous for protection of materials such as refractory metals and carbon-carbon composites. Current status of activity in the field is described and suggestions are made for future work.</p>			
20. DISTRIBUTION/AVAILABILITY OF ABSTRACT <input type="checkbox"/> UNCLASSIFIED/UNLIMITED <input checked="" type="checkbox"/> SAME AS RPT. <input type="checkbox"/> DTIC USERS		21. ABSTRACT SECURITY CLASSIFICATION UNCLASSIFIED	
22a. NAME OF RESPONSIBLE INDIVIDUAL John E.Hove		22b. TELEPHONE (Include Area Code) (703) 578-2869	22c. OFFICE SYMBOL

PREFACE

IDA Project Assignment A-86 of 5 January 1984 from the Defense Advanced Research Projects Agency (DARPA) requests "An Assessment of Selected Areas Potentially Appropriate for DARPA Emphasis in Material Research and Development." Attention initially was directed to carbon-carbon composites and their use in gas turbine engines.

Discussion of the electrical properties of coatings on carbon-carbon composites at a review meeting in April 1986 of a major DARPA-sponsored program led to discussion at that time between the author, Professor G. St Pierre of Ohio State University, and Dr. E. Courtright of Battelle Pacific Northwest Laboratories of the specific topic of electrolytic protection against high-temperature oxidation. There was no reason immediately apparent why this approach, which had not previously been discussed, might not work. Over the next few months the literature was reviewed and the topic was discussed with a reasonably broad spectrum of scientists particularly skilled in the electrical properties of oxide ceramics. The results of this effort, outlined herein, confirmed the theoretical soundness of the approach and led to sponsorship by DARPA of a brief rudimentary examination of the topic. In this examination, conducted at Battelle Pacific Northwest Laboratories, electrolytic protection slowed the oxidation of zircalloy markedly but did not stop it completely.

In this paper, the most probable reason for failure to achieve a zero rate of oxidation in the Battelle tests is identified as the onset of electronic conduction at the electrolyte-substrate interface. It is suggested that this may be avoided by a duplex electrolyte. Additional suggestions are made for future work on the topic.

ABSTRACT

This paper describes and discusses protection of materials against high-temperature oxidation achieved by coating their surfaces with a solid electrolyte and making the substrate cathodic in an electrolytic cell created by a potential applied across the electrolyte. This approach, similar in nature to the widely followed practice of cathodic protection against aqueous corrosion, is shown to be theoretically sound and potentially advantageous for protection of materials such as refractory metals and carbon-carbon composites. Current status of activity in the field is described and suggestions are made for future work.

CONTENTS

Preface	ii
Abstract	iii
I. INTRODUCTION, BACKGROUND, AND OXIDATION THEORY.....	1
A. Introduction.....	1
B. Background.....	1
C. High-Temperature Oxidation	3
II. ELECTROLYTIC PROTECTION	8
A. Voltages Required	9
B. Resistances Required	12
C. The Electrolyte	13
D. The Anode	17
III. LIMITATIONS AND POSSIBLE IMPEDIMENTS	19
A. Atomic and Molecular Diffusion	19
B. Chemical Compatability and Volatile Product Effects	20
C. Control of Potentials Across the Electrolyte	21
D. Protons and Other Cations	22
E. Availability of Materials	23
IV. CURRENT STATUS, CONCLUSIONS, AND RECOMMENDATIONS	25
A. Current Status	25
B. Conclusions	28
C. Recommendations.....	28
V. REFERENCES	28
Appendix. Sensitivity to Electrical Resistances	A-1

LIST OF FIGURES

1.	Effect of electric field on oxidation of silicon at 850 °C. After Jorgensen.	6
2.	Po ₂ (d) Potentials with Fluorite Electrolytes.....	11
3.	Schematic diagram of the variation of electrical conductivity of ThO ₂ and ThO ₂ (Y ₂ O ₃) solid solutions with oxygen pressure at constant temperature.	15
4.	Variation of the electrical conductivity of ThO ₂ with oxygen pressure at 1000 °C. Results are from <i>Rudolph</i> (Ref. 12), <i>Bauerle</i> (Ref. 13), and <i>Lasker and Rapp</i> (Ref. 14).....	15
5.	Total conductance of ThO ₂ as a function of oxygen pressure.	16
6.	Electrolytic domains for ZrO ₂ (CaO) and ThO ₂ (Y ₂ O ₃) electrolytes.	16
7.	Resistivity of selected perovskite-structure oxides.....	18
8.	Diameter increase after 1100 °C/60 min. Plasma sprayed ZrO ₂ *20% Y ₂ O ₃ on Zircalloy.....	26
9.	Effect of applied voltage on oxide growth of zircalloy at 1100 °C/60 min. Electrolyte: Plasma sprayed ZrO ₂ *20% Y ₂ O ₃	26
A-1	Specimen for voltage calculation.	A-3
A-2	Temperature, resistance, thickness, and voltage profiles.....	A-5
A-3	Combustor rig vane specimen geometry	A-6
A-4	Compensating contact surface.....	A-6

LIST OF TABLES

1. $P_{O_2}^{(d)}$ Potentials with Fluorite Electrolytes.....	10
2. Oxidation Reactions.....	12
3. Power Requirements vs Specific Resistances	13

I. INTRODUCTION, BACKGROUND, AND OXIDATION THEORY

A. INTRODUCTION

Operation of many types of propulsion systems and power generation equipment at temperatures higher than those at which they now operate would permit increased thermodynamic efficiency and consequent improvements in equipment performance attributes, such as specific thrust, power output, and fuel consumption. In general, equipment operating temperatures are limited by the capabilities of available materials of construction. There has thus been, for many years, a constant need to develop materials capable of withstanding ever higher operating temperatures. In response to this need, the refractory metals, molybdenum, niobium (columbium), tantalum, tungsten, and alloys based on these metals have been developed and brought to a stage of engineering availability. More recently, carbon-carbon composites capable of very-high-temperature operation have been developed. These, however, suffer from poor oxidation resistance at high temperatures. It is the purpose of this paper to suggest a new approach to overcoming this drawback.

B. BACKGROUND

Starting in 1949, and for the next 20 years, extensive efforts were devoted to development of oxidation resistance in alloys of the refractory metals Mo, Nb, Ta, and W. These involved various alloy modifications and coatings, including, in the case of niobium, hot-dip galvanizing. Both alloying and coatings produced marked improvements in the high-temperature oxidation performance of the alloys compared with the uncoated, unalloyed metals. However, the large alloy additions required to achieve reasonable oxidation resistance, e.g., 27 Ti, 7 Cr in Nb, and 38 Ni in Mo (compositions in wt. %), reduced alloy strengths to such an extent that those alloys became noncompetitive and reliance was placed on coatings for the higher strength refractory alloys.

A variety of coatings have been developed and tested extensively on refractory alloys. Most contain silicon, which is believed to contribute to coating performance by forming SiO_2 on oxidation which impedes further oxidation by acting as a diffusion barrier. A variety of environmental factors, e.g., temperature, gas composition, and pressure, influence the life expectancy of a coated refractory metal part. However, a life of several hundred hours in cyclic furnace exposure at about 2600 °F has been achieved. After about 1970 there was very little further development work on coatings for refractory metals. All approaches that seemed to have any chance of success had been explored.

Notwithstanding laboratory test results showing reasonably long lives for coated specimens in oxidation tests, attempts to use coated columbium or molybdenum in vehicle construction are not particularly comforting. The X-20 (Dyna-Soar), the Advanced Structural Concepts Experimental Program (ASCEP) and the Aerothermodynamic Structural System Environmental Tests (ASSET) programs all used coated columbium and/or coated molybdenum heat shields. All testing programs had problems with integrity and life of the refractory coating and there was little success in developing durable coatings for refractory metal mechanical fasteners.

More recently, carbon-carbon composites have been added to the list of desirable high-temperature materials that need protection against oxidation. Efforts are being made to obtain oxidation resistance both by coatings on and by additions to the carbon-carbon composites themselves. The carbon-carbon heat shields on the Space Shuttle Orbiter are protected by a silicon carbide surface layer. They are exposed to temperatures up to 2600 °F during reentry and appear to be holding up well. In development efforts directed toward higher temperature engine applications it appears that silicon-carbide-based coatings may be useful at temperatures up to about 3100 °F but not much above that. Silicon nitride, iridium, and borides have some potential for use at higher temperatures but there are few development approaches available.

In view of the foregoing, it is clear that further progress in protective coatings for both the refractory metals and for carbon-carbon composites is necessary if full advantage is to be taken of their high-temperature strengths. For the refractory metals, more defect- and damage-tolerant coatings are needed and for carbon-carbon, coatings usable above 3100 °F are needed.

Electrolytic protection against corrosion in liquid electrolytes has been standard engineering practice for many years. On ships, the use of zinc to protect steel hulls,

particularly in areas near bronze propellers, is widespread. Magnesium-lithium alloys are used for corrosion protection in household water heaters. In addition to the use of anodic metals such as zinc and magnesium alloys, extensive use is made of inert anodes, such as carbon, coupled electrically to a structure such as a pipeline buried in a corrosive soil. In this case, the protecting potential, instead of arising naturally from differing electrolytic solution potentials, is applied externally via a battery or other direct current source. Voltage and current requirements are quite modest. Typical current requirements for cathodic protection of steel pipeline in soil are 1-3 mA/ft² (Ref. 1).

Although in the foregoing examples the electrolyte is water or a water solution, there is no electrochemical reason why this must be so. Electrochemical reactions with molten salts as electrolytes are common, such as the Hall cell for aluminum production. Batteries with non-aqueous electrolytes are also common. It is also not necessary that the electrolyte be a fluid. Solids such as yttria-stabilized zirconia, a good conductor of oxygen ions, are used as electrolytes in fuel cells and in coulometric titration.

Recognizing oxidation of metals or carbon as an electrochemical reaction and noting the existence of solid electrolytes stable at high temperatures suggests that high-temperature oxidation may be prevented, as aqueous corrosion now is, by making the material to be protected the cathode in an electrolytic cell.

C. HIGH-TEMPERATURE OXIDATION

Kofstad (Ref. 2) has summarized the Wagner oxidation theory which he characterizes as the most important single contribution to our understanding of the high-temperature oxidation of metals. Wagner's theory applies to compact scales of reaction products. He uses an electrochemical cell analogue where the growing oxide film serves as the cell electrolyte for ionic transport as well as the external circuit for the conduction of electrons. Two effects are produced by the ionic current: the ionization of metal atoms, $M \rightarrow M^{+b} + be^{-}$, and the ionization of oxygen atoms, $O_2 + be^{-} \rightarrow b/2O^{-2}$. The greatest part of the current is carried by the electrons. His theory assumes that volume diffusion of vacancies, reacting ions, or electrons across the scale is rate controlling and that the driving force for the reaction is the free energy change associated with the formation of the oxide from the metal and the oxygen gas. Wagner's theory, first presented in 1933, provides an understanding of parabolic oxidation that has stood the test of time. In it, the number of particles of a species i passing through 1 cm² of a perpendicular plane per second, (J_i) is given by

$$j_i = \frac{-t_i \sigma}{Z_i^2 e^2} \left(\frac{d\mu_i}{dx} + Z_i e \frac{d\phi}{dx} \right).$$

t_i is the fraction of total current carried by this species, σ is the conductivity, Z_i is the number of charges on this species, e the charge on the electron, $d\mu_i/dx$ and $d\phi/dx$ are the gradients in chemical potential and electric field strength, respectively. When $d\mu/dx = -Z_i e (d\phi/dx)$, the right side of the equation becomes 0, and transport of that particle through the scale ceases. It is consistent with Wagner's theory that an applied potential across a surface layer of an oxygen ion conductor should influence the rate of oxygen transport through the layer and, when in the right direction and of sufficient strength, should stop it altogether.

Wagner derived the rate of reaction using thermodynamic and chemical reasoning as

$$\frac{dn}{dt} = - \left\{ \frac{\bar{t}_e (\bar{t}_m + \bar{t}_x) \sigma}{e^2 b^2 r^2} \Delta G \right\} \frac{1}{\Delta x},$$

where the t 's are the average transference numbers, σ is the specific conductivity, b and r are the valence and number of anions per oxide molecule, ΔG is the change in free energy for oxide formation, and Δx is the scale thickness.

Hoar and Price (Ref. 3) also considered the oxidation reaction as an electrochemical cell in which the oxide scale serves as an electrolyte for ion transport and as a circuit for transport of electrons. The electromotive force of the cell, E , is determined by the free energy change of the oxidation reaction, $\Delta G \approx -breE$. The resistance of the cell is the sum of the ionic and electronic resistances. With this model, see sketches, and assuming that Ohm's law ($i = E/R$) holds, they derive the identical rate equation given above by Wagner. This demonstrates that there is no conflict between oxidation theory and electrolytic treatment of the oxidation reaction.

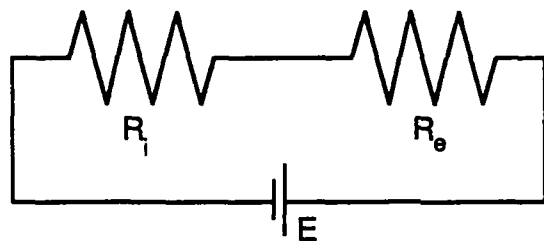
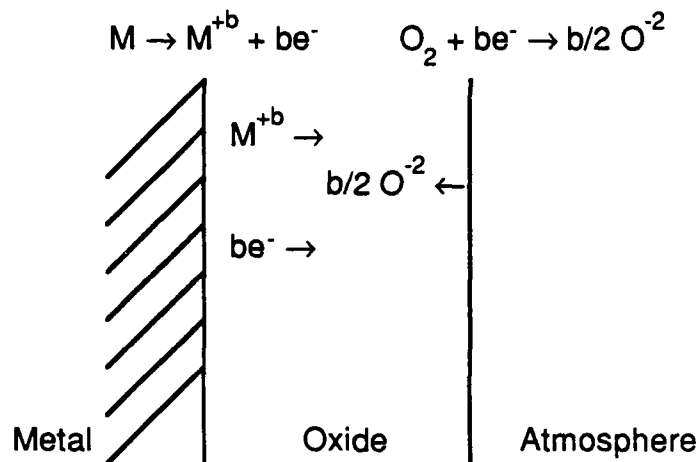

Kröger and Berz (as in Ref. 2) have treated the oxidation reaction as an electrochemical reaction and have considered the effect of an externally applied potential across the scale. Kröger, in particular, showed that with an externally applied emf and a constant current passed through the metal oxide, the greatest effect on oxidation could be obtained if the film had predominately ionic conductivity. In this case, $\bar{t}_e \ll \bar{t}_m + \bar{t}_x$, where the \bar{t} 's are transport numbers for electrons, metal ions, and oxide ions, respectively; and, therefore, $R_e \gg R_i$. Both derive the rate equation

$$\frac{dn}{dt} = \frac{(\bar{t}_m + \bar{t}_x) \sigma}{rbe \Delta x} (E - E_{ext})$$

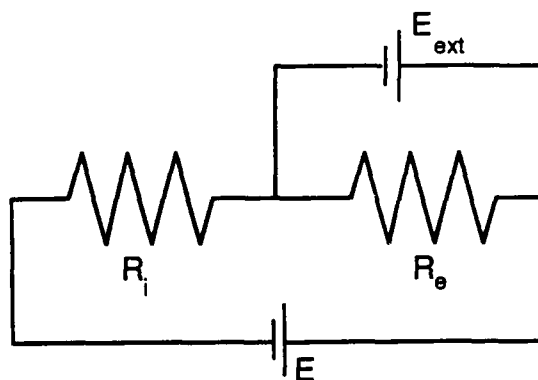

It is clear that if the applied external potential is equal and opposite to the potential derived for the reaction from the free energy change the rate of oxidation will be zero.

Jorgensen (Ref. 4), applied porous platinum electrodes to a thin SiO_2 layer on the surfaces of a silicon single crystal. He then exposed the crystal to further oxidation at 850°C while an electric current was flowing through the crystal. The current and consequent potential was in one direction through the scale as it entered the crystal. It was in the opposite direction as it left as shown in Fig. 1. He observed an increased oxidation rate with the accelerating field. With the retarding field the rate of oxidation was lower. When the SiO_2 film had grown to yield a potential across it approximately that derived from the reaction-free energy, oxidation ceased. The test set up and results (Fig. 1) were as follows.

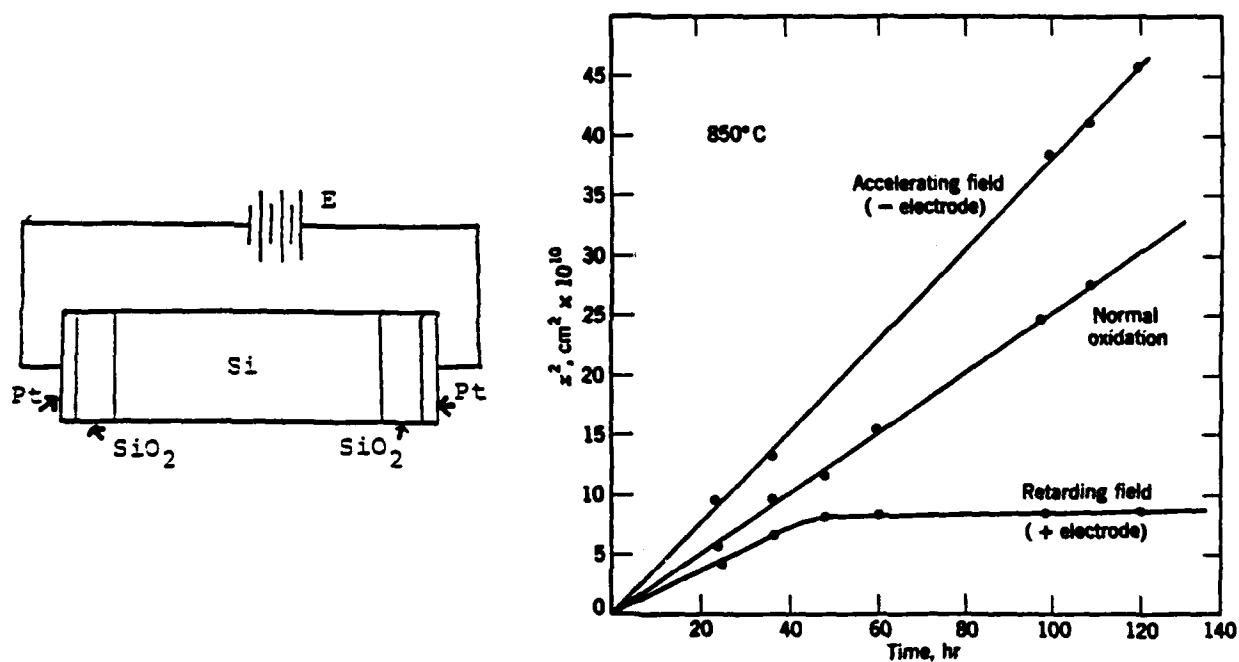

Figure 1. Effect of electric fields on oxidation of silicon at 850°C . After Jorgensen. (Ref. 4)

In later work on silicon, Jorgensen (Ref. 5) demonstrated that the oxidation and electrolysis effects of electric fields applied across SiO_2 layers are precisely what one would predict from electrochemical theory. Stopping voltages measured in experiments agreed with calculated values within 1 percent. In work on zinc (Refs. 5, 6) Jorgensen again found that an applied electric field, depending on its magnitude and direction, could accelerate, retard, or stop oxidation.

Many other investigations of applied electric field effects on Cu, Fe, Ni, Al, Zn, W, Zr, superalloys and Ag have been reported, with results varying from no observed effect to effects opposite those reported by Jorgensen. Bose (Ref. 7), for example, found that oxidation of iron in CO-CO₂ gas mixtures was accelerated when the iron was made cathodic in an electrochemical cell. This situation is clearly attributable to the electrical and electrolytic properties of the scales across which the potentials were applied. The metal oxides are good electronic conductors, poor ionic conductors, or both. They generally do not meet the requirements for an appropriate electrolyte and varying effects of impressed currents and potentials are to be expected.

II. ELECTROLYTIC PROTECTION

All of the work noted in the literature involved potentials across scales produced by reaction of the substrate with the environment, predominantly oxide scales. There has been no work uncovered in which a solid electrolyte has been selected for its ionic and electronic conductivity characteristics and been applied deliberately to form a protective electrochemical cell. The first known work of this type, not yet published, is that sponsored by DARPA at Battelle Pacific Northwest Laboratories in which stabilized zirconia and hafnia electrolytes were applied to zircalloy and carbon. In that work, to which reference will be made subsequently, electrolytic protection decreased markedly but did not completely stop oxidation of the zircalloy substrate. The carbon specimen failed by a mechanism unrelated to electrolytic protection, i.e., from an uncoated area.

Schematically, electrolytic protection might be applied as follows:

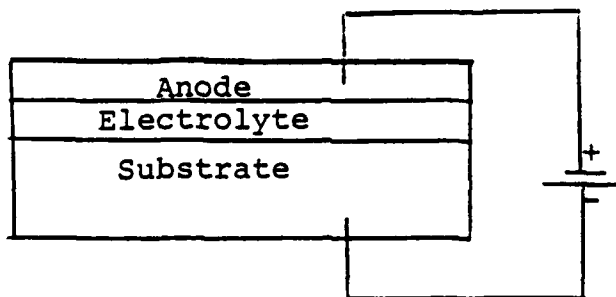

The substrate to be protected might be coated with an oxygen-ion-conducting solid electrolyte as the first coating layer. On top of that a layer of an electronic conductor would be deposited. The substrate would then be connected electrically to the outer layer through a direct current potential source so that an electric field is applied across the electrolyte layer. The substrate would be made the cathode; i.e., it would be connected to the negative terminal of the power source.

A. VOLTAGES REQUIRED

Required voltages can be derived from the Nernst equation based on the premise that oxidation will stop when the driving potential calculated from the free energy change of the oxidation reaction and the applied potential are equal and opposite each other. It is also to be expected that oxidation will stop when the applied potential reduces the oxygen partial pressure at the electrolyte-substrate interface to the dissociation partial pressure of the respective oxide. Thus:

$$e = \frac{-\Delta G}{nF} = \frac{RT}{nF} \ln \frac{P_{O_2}^{(Ref)}}{P_{O_2}^{(d)}} \text{ Nernst}$$

$$\text{For } P_{O_2}^{(Ref)} = 0.21 \text{ atm, } \ln P_{O_2}^{(d)} = \frac{\Delta G (\text{cal/mole } O_2)}{RT(K)},$$

where $R = 1.986 \text{ cal/mole K}$, and $n = \text{number of electrons involved in the reaction (the valence number)}$.

Given the required $P_{O_2}^{(d)}$ at the electrolyte-substrate interface, the required potential across a surface electrolyte may be calculated from the assumed reference oxygen pressure and the n value for the electrolyte, e.g., for ZrO_2 , $n=4$. With Faraday's constant $96,520 \text{ coulombs/mole}$, $R = 8.314 \text{ J/gmole K}$.

Although the aforementioned calculations appear quite simple, straightforward, and precise, there are many considerations that render the calculated values open to question. The most significant of these involve the assumptions made about the reactions that are occurring. For example, in oxidation of niobium it would seem reasonable to assume that the first oxide to form would be NbO and that calculations based on free energy values for this oxide taken from the JANAF tables should give accurate voltage values. However, the JANAF tables give values for the oxide produced from its elements, whereas the oxygen is reacting not with pure niobium but with a niobium-oxygen solid solution. Depending on the temperature and oxygen partial pressure, there may also be a question as to whether NbO is, in fact, the first oxide to form. Furthermore, if oxygen dissolving in niobium embrittles the metal, prevention of oxidation damage may require prevention of such dissolution rather than just the formation of NbO .

In addition to uncertainties of the foregoing type, there are additional factors such as overvoltages and contact potentials that render the simple calculated values open to question. Nevertheless, if gross errors in the oxidation reaction assumptions are avoided,

there is no reason yet to assume that calculated values will vary greatly from experimental values. Experience with silicon and zinc supports this position.

With the foregoing reservations in mind regarding the accuracy of the calculated values and using free energy values taken from either the JANAF tables or the *Handbook of Chemistry and Physics* (Ref. 8), the values in Table 1 for the potentials required to stop the oxidation reactions and the dissociation oxygen partial pressures for the respective oxides were calculated.

Table 1. $P_{O_2}^{(d)}$ Potentials with Fluorite Electrolytes

Reaction	Temperature, K	$P_{O_2}^{(d)}$, atm	E for $P_{O_2}^{(d)}$, $P_{O_2}^{(Ref)} = .21$ $n=4$
C + 1/2 O ₂ → CO	1273	4x10 ⁻¹⁹	1.12 volts
	2200	4x10 ⁻¹⁵	1.49 volts
Mo + O ₂ → MoO ₂	1273	1.8x10 ⁻¹⁵	0.89 volt
	2200	1x10 ⁻⁵	0.47 volt
Nb + 1/2 O ₂ → NbO	1273	9x10 ⁻²⁶	1.54 volts
	2200	1.6x10 ⁻¹¹	1.10 volts
Ti + 1/2 O ₂ → TiO	1273	2.5x10 ⁻³⁵	2.14 volts
	2200	8.5x10 ⁻¹⁷	1.68 volts
W + O ₂ → WO ₂	1273	1.6x10 ⁻¹⁵	0.89 volt
	2200	1.1x10 ⁻⁵	0.47 volt
Zr + O ₂ → ZrO ₂	1273	7x10 ⁻³⁶	2.17 volts
	2200	4.6x10 ⁻¹⁷	1.71 volts

Table 1 illustrates that although dissociation oxygen partial pressures can be very low indeed, the potentials required to produce them are quite modest. The voltage calculations were for fluorite-type electrolytes ($n = 4$) in 1 atm of air. Fluorite-type electrolytes are those having a crystal structure like that of CaF₂, e.g., ThO₂. These electrolytes are selected for their special properties such as permeability, thermal shock resistance, resistance to chemical attack by electrode materials and, most importantly, ionic with very low electronic conductivities in some oxygen pressure/temperature regimes.

The results of similar additional calculations of the potentials required across fluorite-type electrolytes to give oxygen partial pressures at the electrolyte-substrate interface equal to the dissociation partial pressures for various oxides are shown in Fig. 2. The reactions plotted for the various elements are shown in Table 2. It appears that ZrO₂,

Potentials for Oxide Dissociation Oxygen Partial Pressure, $P_{O_2}^{(d)}$
 at Substrate-ZrO₂ Electrolyte Interface, Volts

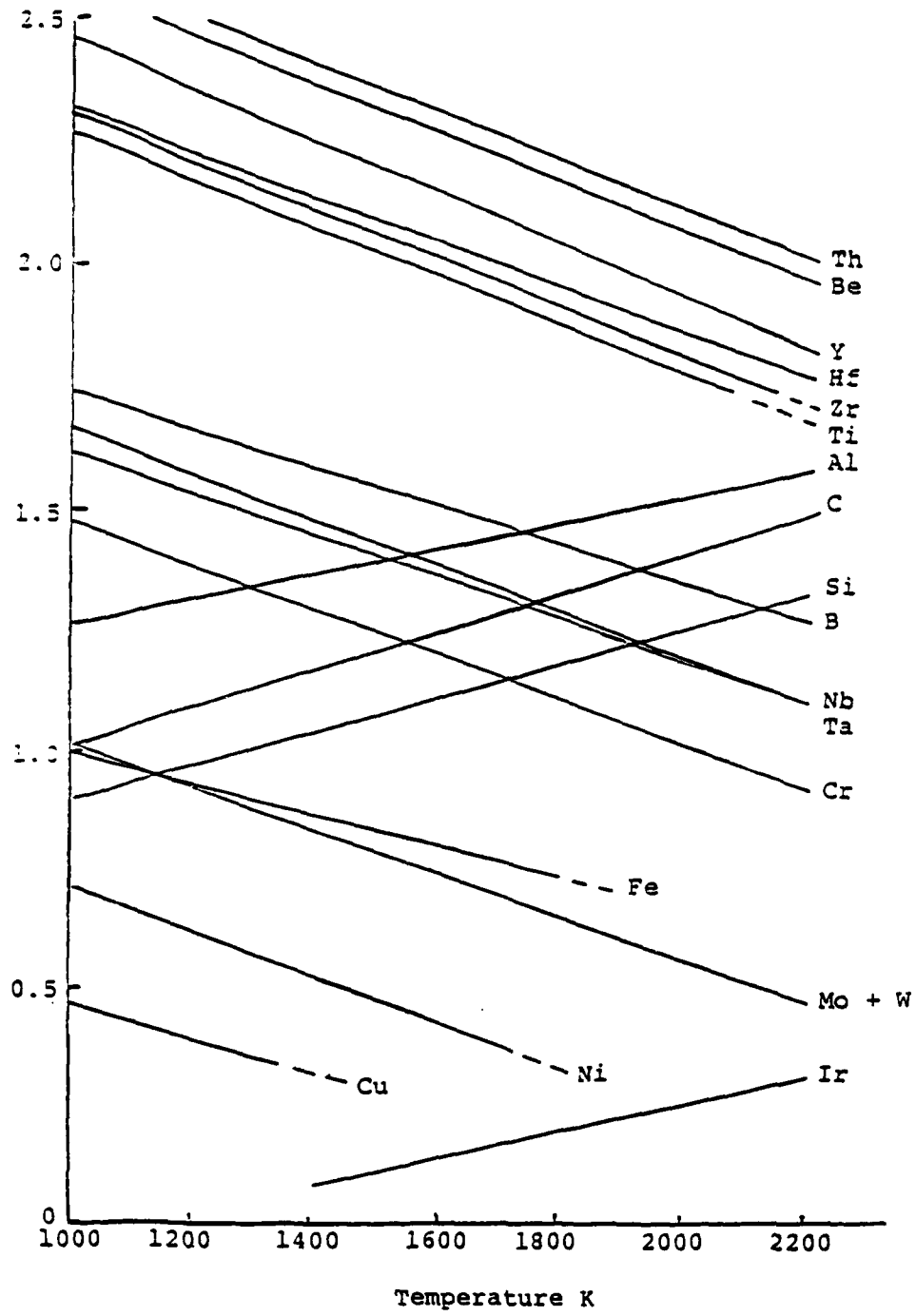

Figure 2. $P_{O_2}^{(d)}$ Potentials with Fluorite Electrolytes

HfO₂ and ThO₂ electrolytes have a reasonable margin in potential for protection of carbon, molybdenum, and tungsten; they have a somewhat less potential margin for niobium and tantalum and should not be expected to be able to protect beryllium. The potentials required to protect beryllium should electrolyze zirconia and hafnia.

Table 2. Oxidation Reactions

Element	Reaction
Th	$\text{Th} + \text{O}_2 \rightarrow \text{ThO}_2$
Be	$\text{Be} + \frac{1}{2}\text{O}_2 \rightarrow \text{BeO}$
Y	$2\text{Y} + \frac{3}{2}\text{O}_2 \rightarrow \text{Y}_2\text{O}_3$
Hf	$\text{Hf} + \text{O}_2 \rightarrow \text{HfO}_2$
Zr	$\text{Zr} + \text{O}_2 \rightarrow \text{ZrO}_2$
Ti	$\text{Ti} + \frac{1}{2}\text{O}_2 \rightarrow \text{TiO}$
Al	$2\text{Al} + \frac{1}{2}\text{O}_2 \rightarrow \text{Al}_2\text{O}$
C	$\text{C} + \frac{1}{2}\text{O}_2 \rightarrow \text{CO}$
Si	$\text{Si} + \frac{1}{2}\text{O}_2 \rightarrow \text{SiO}$
B	$2\text{B} + \frac{3}{2}\text{O}_2 \rightarrow \text{B}_2\text{O}_3$
Nb	$\text{Nb} + \frac{1}{2}\text{O}_2 \rightarrow \text{NbO}$
Ta	$2\text{Ta} + \frac{5}{2}\text{O}_2 \rightarrow \text{Ta}_2\text{O}_5$
Cr	$2\text{Cr} + \frac{3}{2}\text{O}_2 \rightarrow \text{Cr}_2\text{O}_3$
Fe	$\text{Fe} + \frac{1}{2}\text{O}_2 \rightarrow \text{FeO}$
Mo	$\text{Mo} + \text{O}_2 \rightarrow \text{MoO}_2$
W	$\text{W} + \text{O}_2 \rightarrow \text{WO}_2$
Ni	$\text{Ni} + \frac{1}{2}\text{O}_2 \rightarrow \text{NiO}$
Cu	$\text{Cu} + \frac{1}{2}\text{O}_2 \rightarrow \text{CuO}$
Ir	$\text{Ir} + \text{O}_2 \rightarrow \text{IrO}_2$

B. RESISTANCES REQUIRED

Although electrolytic protection demands only a specified voltage across the surface electrolyte and is silent on its resistance, attempts to apply electrolytic protection quickly impose constraints on the resistances necessary and permissible in both the electrolyte and the electrode surface layers.

Substrates of carbon and refractory metals will be blocking electrodes in the surface electrolytic protection cell and will not furnish oxygen ions to the electrolyte once those initially present are pumped away. Very low ionic resistance in the electrolyte is not an obvious requirement. However, because the electrolyte will be a comparatively thin coating, its specific electronic resistance will have to be high to avoid excessive power requirements. For example, 36 turbine vanes 2 in. x 4 in., if coated with an electrolyte 0.005 in. thick, would require about 1 kW of power for protection (at 2 V) if the electrolyte has a specific electronic resistance at a temperature of 1430 Ω -cm. Lower resistance would mean higher power requirements. Therefore, specific electronic resistance in the thousands of Ω -cm will be required in the electrolyte at operating temperature.

Table 3, reflecting $E = IR$ calculations for 36 carbon turbine vanes 2 in. x 4 in. protected by a four-layer coating of the type illustrated in the Appendix, shows that increasing electrode resistances require increased electrolyte resistances to avoid appreciable increases in power requirements. Layer thicknesses here were 0.002 in. and the potential used to protect carbon was 1.17 V.

Table 3. Power Requirements vs Specific Resistances

Electrode Specific Resistance, Ω -cm	Electrolyte Specific Resistance, Ω -cm	Power Required, kW
0.001	1275	1
0.01	1275	3
0.01	2500	1
0.1	6650	1

Electronic resistance in the electrode layer(s) should be as low as possible to lower power requirements and to ease the task of providing the desired potential drop across all parts of the electrolyte. From Fig. 2 it is seen that the permissible variation in potential across the electrolyte is quite small. The potential must be at or above that for the material to be protected but below that of the electrolyte material in order to avoid electrolysis. Actually, as will be shown later, it may have to be considerably below the electrolysis potential to avoid the onset of excessive electronic conduction in the electrolyte.

C. THE ELECTROLYTE

The most successful of the oxygen-ion-conducting oxide electrolytes have been those based on one of the group IVB oxides, ZrO_2 , HfO_2 , CeO_2 , or ThO_2 , with additions

of either an alkaline earth oxide, Sc_2O_3 , Y_2O_3 , or a rare earth oxide. In contrast with the high ionic conductivity requirements of fuel cells, pumps, and such applications it was noted above that since the substrate in electrolytic protection will be a blocking electrode which, after an initial surge, will not supply oxygen ions to the electrolyte. Therefore, high ionic conductivity will probably not be required. However, reasonably good ionic conductivity may be desirable to insure that the electrolyte layer, even when minor defects are present, will prevent atomic and molecular oxygen from reaching the substrate. An oxygen sticking coefficient of nearly 1 for chemisorption and good ionic conductivity may be necessary to accomplish this behavior. However, ionic conductivity needs lower than those in fuel cell electrolytes, for example, may afford a valuable degree of freedom in attaining necessary electronic resistance. Electrolytes of the oxygen-ion-conducting fluorite type, as exemplified by ThO_2 , exhibit conductivities which vary with oxygen pressure as well as with temperature. Fig. 3, from Ref. 9, illustrates schematically the variation in conductivity of $\text{ThO}_2\text{-Y}_2\text{O}_3$ solid solutions with composition and oxygen pressure at constant temperature. Figures 4 and 5, from the same reference, report variation with oxygen pressure and temperature.

The flat central portion of these curves, taken from work by the authors shown and Bransky and Tallan (Ref. 10) is the region of high oxygen ion conductivity and low electronic conductivity. These are the conditions required for effective use as an electrolyte. Because the mobility of electrons, i.e., the mean particle velocity per unit potential gradient is usually 100 to 1000 times greater than ionic mobility, ionic conductivity will predominate only when the concentration of electronic defects is less than that of ionic defects by a factor of this magnitude. Generally, for effective use of the fluorite type oxides as electrolytes, the ionic transference number t_i or ratio of current carried by ions to total current is required to be 0.99 or more. Figure 6, from Ref. 8, reporting on work by J.W. Patterson (Ref. 11) shows the temperature and oxygen pressure conditions under which $t_i \geq 0.99$ will be obtained in stabilized zirconia and stabilized thoria electrolytes. These regions (within the lines) are called the electrolytic domain. Other work places the bottom line for thoria at values lower than those shown, e.g., 10^{-34} at 1000°C .

From the foregoing it can be seen that there are temperature and oxygen pressure restrictions on materials to be used as electrolytes in electrolytic protection. Zirconia is better under high oxygen pressures and thoria under low oxygen pressures. If one is to stay within the electrolytic domain everywhere in a zirconia coating at 1000°C the maximum potential that could be applied at atmospheric pressure would be about 1 V.

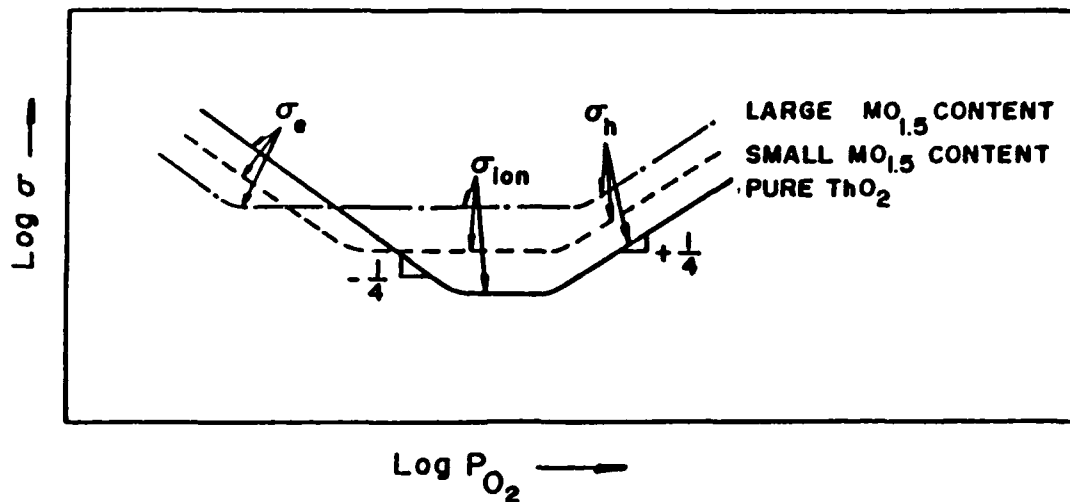

Figure 3. Schematic diagram of the variation of electrical conductivity of ThO_2 and $ThO_2(Y_2O_3)$ solid solutions with oxygen pressure at constant temperature. Source: Ref. 9.

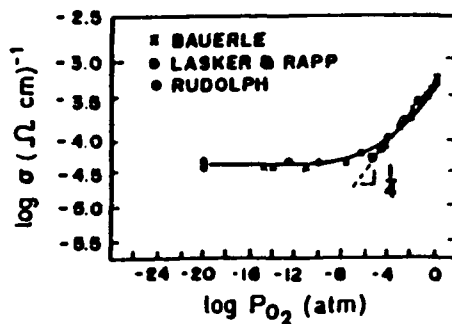

Figure 4. Variation of the electrical conductivity of ThO_2 with oxygen pressure at 1000 °C. Results are from Rudolph (Ref. 12), Bauerle (Ref. 13), and Lasker and Rapp (Ref. 14).

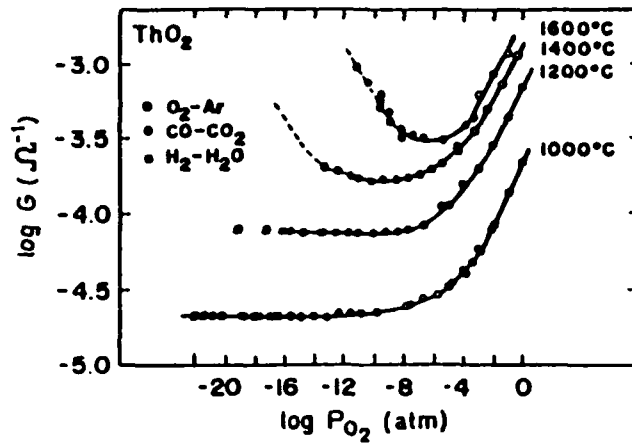

Figure 5. Total conductance of ThO_2 as a function of oxygen pressure (Ref. 10).

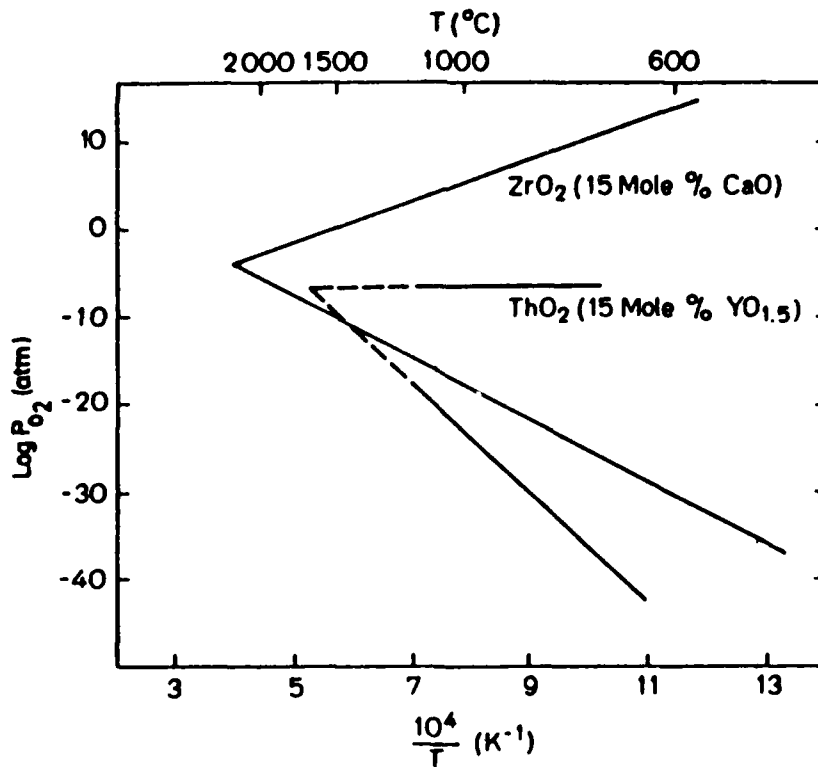

Figure 6. Electrolytic domains for $\text{ZrO}_2(\text{CaO})$ and $\text{ThO}_2(\text{Y}_2\text{O}_3)$ electrolytes. Source: Ref. 11.

This, from Fig. 1, would not be expected to protect carbon or niobium and would be barely adequate for molybdenum and tungsten. If the low pressure domain limit for thoria is 10^{-34} atm it could tolerate 2.1 V in the low oxygen pressure region but would be outside its electrolytic domain at atmospheric pressure, i.e., $P_{O_2} = 0.21$ atm.

In addition to the required electrical characteristics, the electrolyte layer must be compatible with the substrate both mechanically and chemically, and must bond well to the substrate. A reasonable match in coefficients of thermal expansion can be made between ZrO_2 and Nb (7.6 vs $7.1 \times 10^{-6}/^{\circ}C$) and HfO_2 and Ta (5.9 vs $6.5 \times 10^{-6}/^{\circ}C$). However, it is not clear that anything can be done to accommodate a 2D carbon-carbon composite with its greatly anisotropic expansion characteristics other than perhaps to make the electrolyte porous (non-interconnecting pores) and thus lower its effective elastic modulus of elasticity, or to arrange cracking behavior which is tolerable under operating conditions.

D. THE ANODE

The objectives of work on electrode ceramics for fuel cells, magneto hydrodynamic power generators, and electrolytic cells are similar to those required for electrolytic protection. The objectives are high electronic conductivity, stability, resistance to the environment, and compatibility with the underlying electrolyte and substrate. For fuel cells, high electronic conductivity at temperatures below $1000^{\circ}C$ is desired to permit fuel cell operation at lower temperatures, thereby improving life and reliability. In electrolytic protection, electrode materials that will permit operation at very high temperatures, e.g., $>2000^{\circ}C$ as well as at lower temperatures, will be needed. Therefore, many of the ceramic conductors developed for fuel cell use will be inappropriate for electrolytic protection anodes because they lack stability at the higher temperatures.

Fig. 7, from Ref. 15, page 373, shows the temperature dependence of the resistivity of some highly conductive perovskite oxides. A very low specific resistance will be required, since electrical contact will have to be made some distance from the area exposed to the high-temperature, hostile environment and the anode coating, to be practical, must be thin.

In addition to low resistance, the change in resistance with temperature may not be too large; otherwise, the task of keeping the potential drop across the electrolyte within the necessary narrow limits may be rendered impractical. Variation such as that shown in Fig. 7 for $La_{0.8}Sr_{0.2}CrO_3$ appears to be acceptable. As will be shown in the Appendix, changes in electrode resistance could be compensated for by changing electrode thickness to keep

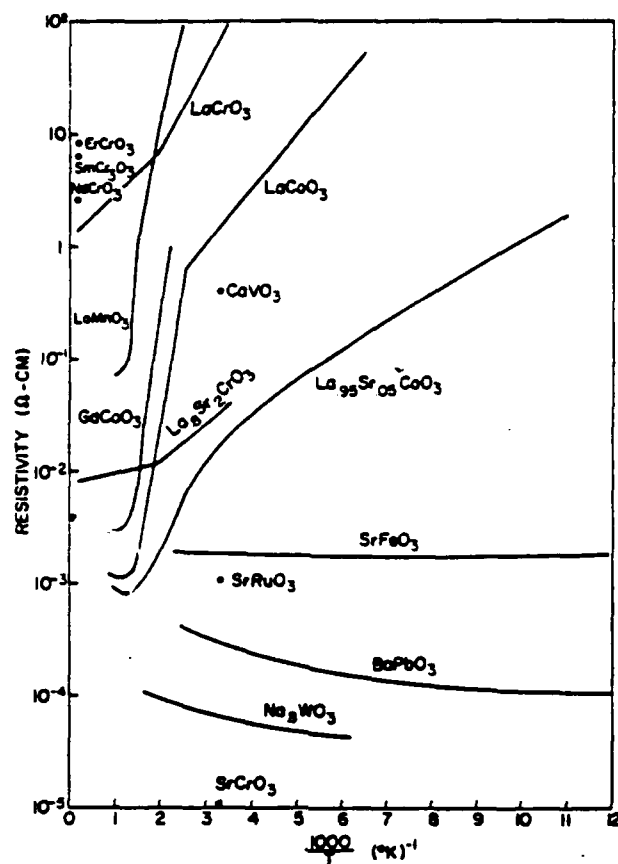

Figure 7. Resistivity of selected perovskite-structure oxides.

constant the ratio of specific resistance to thickness, (ρ/t). However, if specific resistance should change one or two orders of magnitude with the temperature changes of design interest, a corresponding change would have to be made in the electrode layer thickness, and this might be impracticable. A slope in the temperature range of interest such as that shown in Fig. 7 for LaCoO_3 would be cause for concern.

In theory, oxygen ions are to be oxidized at the anode-electrolyte interface in cells of the type being discussed herein, producing oxygen atoms and molecules. A requirement for a successful anode should be that it permit transit of these atoms and molecules to the environment. In fuel cells, this transit is facilitated by making the anode porous, and similar action would seem appropriate in anode coatings used for electrolytic protection.

A reasonable match in coefficient of thermal expansion between the anode layer and the underlying substrate-electrolyte combination is desirable. However, except for failure by spalling or separation, it is not clear that differential thermal expansion should be a major hazard for the anode. A large number of small cracks produced by CTE mismatch may have little effect on electrical conductivity and may, in fact, help in oxygen transfer.

III. LIMITATIONS AND POSSIBLE IMPEDIMENTS

The previous discussion indicates that oxidation and electrochemical theory predict that it should be possible to protect materials from high-temperature oxidation by coating their surfaces with an oxygen-ion-conducting electrolyte and impressing across that electrolyte a potential which will reduce the oxygen pressure at the substrate-electrolyte interface below the dissociation pressure of the substrate oxide. By using appropriate materials for the electrolyte and outer anode layers it seems clear that electrolytic protection should work. However, a variety of concerns are related to its practicability.

A. ATOMIC AND MOLECULAR DIFFUSION

Uncharged oxygen atoms or molecules should be unaffected by an electric field. One might therefore fear that diffusion of these species through grain boundaries, pores, pinholes, and cracks would defeat protection unless the electrolyte layer were free of all such channels. Requiring perfection in the electrolyte layer would essentially disqualify the approach, except perhaps for very limited special applications. However, there is a reasonable basis for optimism that perfection will not be required.

If the sticking coefficient for chemisorption of oxygen onto the electrolyte is high, i.e., near 1, and if, thereafter, the ionized oxygen is pumped away from the substrate, it seems reasonable that unless the crack or pinhole is gross, atomic and molecular oxygen would inevitably hit the electrolyte, be ionized and pumped away before reaching the substrate. Work at Battelle Pacific Northwest Laboratories indicates that the sticking coefficient for chemisorption of oxygen on zirconia is, in fact, approximately 1 (Ref. 16).

Expecting the foregoing mechanism for disposing of atomic and molecular oxygen to work places additional constraints on the electrolyte. Adequate conductivity for electrons and/or electron holes must be provided to support the oxygen ionization. Bergmann and Tannenberger (in Ref. 17, p. 186) cite hole conduction as the transport limiter in oxygen absorption with a platinum/zirconia/air three-phase boundary. The defect structure in the

electrolyte must not only provide the high sticking coefficient but must permit movement of the oxygen through the electrolyte to its disposal site at the electrolyte-anode interface.

Hafnia, zirconia, and thoria which, at this stage, receive particular attention as potential electrolytic oxygen barriers, have thermal coefficients of expansion of 5.9, 7.6, and $9.5 \times 10^{-6}/^{\circ}\text{C}$, respectively (Ref. 18). These compare with 4.3, 4.9, 6.5, and $7.1 \times 10^{-6}/^{\circ}\text{C}$ for the refractory metals W, Mo, Ta, and Nb, respectively. Carbon-carbon composites vary with fiber orientation from near zero longitudinally to perhaps $8 \times 10^{-6}/^{\circ}\text{C}$ transverse to the fibers. The coatings will, in general, be thin compared with the substrate. The combination of high modulus, low ductility thin coatings, wide service temperature range, and disparate coefficients of thermal expansion will force deliberate attention to thermal stress management if spalling or unacceptably large cracks are to be avoided. Selection of materials, management of coating microstructure (porosity?) and selection of coating application temperature are available as tools for thermal stress control.

B. CHEMICAL COMPATIBILITY AND VOLATILE PRODUCT EFFECTS

Potential refractory metal and carbon-carbon composite application areas are predominantly for very high temperature uses, i.e., $> 2700^{\circ}\text{F}$ (1482°C). Superalloys, cooled or uncooled, usually suffice at lower temperatures. Stability of materials, and avoidance of excessive diffusion or chemical reaction at these very high temperatures are legitimate topics of concern. Fortunately, zirconia, hafnia, and thoria are among the highest melting and most stable oxides. Nevertheless, a wide variety of possible chemical reactions are possible, particularly when carbon is the substrate. Many of these produce vapor and gaseous products, and it is not clear that such products, generated at the electrolyte-substrate interface would remain to be equilibrated and have their oxygen pumped away. Professor Rapp of Ohio State has mentioned two such reactions (Ref. 19) for which he and Professor St. Pierre have calculated unacceptably high equilibrium vapor pressures within the temperature range of engineering interest for carbon-carbon. These are:

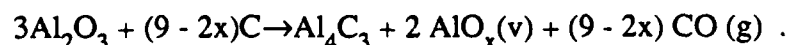
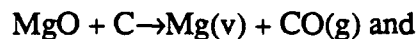

In addition to such reactions, Stringer (Ref. 20), quoting work by Speiser and St. Pierre at Ohio State, shows the high volatility of the oxides of molybdenum and tungsten and their increased volatility as P_{H_2O} in the environment is increased.

One can easily imagine conditions under which chemical reactions or generation of gases at the substrate-electrolyte interface might cause separation or other destruction of the electrochemical cell. However, an immediate response to this might be the use of a four-layer coating, as in Fig. A-1 of the Appendix. The insulator might be chosen to prevent chemical interaction between the electrolyte and substrate and, if it is an electronic insulator, it might simplify the task of applying appropriate electrical potentials.

Chemical compatibility problems should be avoidable by material selection, within as yet undetermined temperature and time constraints, or by use of a barrier coating. The answer to the volatile product question is not so obvious. However, with the evidence indicating that oxygen can be pumped to very low partial pressures where reaction should not occur there is as yet no reason to be pessimistic.

C. CONTROL OF POTENTIALS ACROSS THE ELECTROLYTE

The potentials required to protect various substrates, i.e., to lower oxygen pressure to the dissociation pressure of the substrate oxides at various temperatures, were shown in Fig. 2. Lower potentials should not afford complete protection to a substrate. Potentials higher than those shown for the electrolyte layer should electrolyze the electrolyte. Electrolysis may cause metal deposition or formation of a non-stoichiometric oxide, either of which gives rise to electronic conductivity, which is to be avoided in an electrolyte. The potential required for protection of the substrate and the electrolysis potential of the electrolyte are clearly two limits that may not be exceeded in the protective electrolytic cell. The values in Fig. 2 were calculated for 1 atm of ambient air. They will vary with ambient oxygen pressure in accordance with the Nernst equation.

It was shown above that the conductivity characteristics of the fluorite type electrolytes vary with oxygen pressure as well as with temperature. This imposes an additional limit of the potential that can be imposed across the electrolyte, i.e., the potential may not create oxygen pressure conditions which would render the ionic/electronic conductivity characteristics of the electrolyte unsatisfactory. Specifically, it was indicated that stabilized zirconia would be outside its electrolytic domain at potentials above about 1 V and that thoria would tolerate about 2.1 V but be outside its electrolyte domain at atmospheric oxygen partial pressure. The conventional approach in electrochemical

measurement work to avoiding constraints of this type is to use a duplex cell which appears also to be usable here. The sketch below shows an outside porous anode over a stabilized zirconia layer, a stabilized thoria layer, and the substrate. Thicknesses would be controlled such that the zirconia-thoria interface is at a potential and consequent oxygen pressure within the electrolytic domains of both materials. The zirconia would tolerate the high oxygen pressures, and the thoria would tolerate the low oxygen pressure.

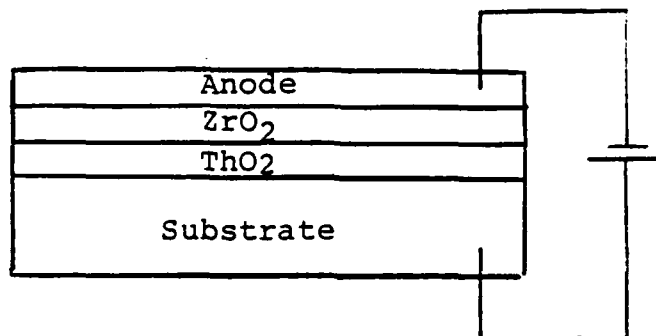

Although there is a modest margin between the theoretical potentials needed to protect refractory metals and carbon-carbon from oxidizing and those which are required to electrolyze the electrolytes, the application and control of appropriate potentials may be anything but a simple task. The outer electrode (anode), because it must be a thin layer on most parts, will have appreciable electronic resistance in the current flow direction, even if its specific resistance is quite low. There will therefore be varying voltage drops, depending on currents and distances required, in the anode. The required voltages will also vary with temperature and with oxygen pressure. Characteristically, these will also vary with time and location.

Design ingenuity will certainly be required in application of electrolytic protection and, depending on part requirements and configuration, there may well be parts to which its application will be impracticable. However, electrolysis and voltage control do not as yet appear to be insuperable barriers to electrolytic protection and even limited success, such as on inlet guide vanes of small, limited-life turbines should make exploitation of the approach well worthwhile.

D. PROTONS AND OTHER CATIONS

Although discussion thus far has concentrated on protection of refractory metals and/or carbon-carbon from high-temperature oxidation by preventing oxygen

electrolytically from reaching the substrate, the same potential that would move oxygen ions away from the substrate may move hydrogen ions toward it. Pumping hydrogen into refractory metals or to an interface with carbon at very high temperature would clearly be a cause for concern. In a hydrocarbon fuel combustion environment water and hydrogen ions are to be expected. Calculations of equilibrium conditions for JP-10 fuel burning with twice as much oxygen as required stoichiometrically show a gas temperature about 3500 °F (1930 °C) and 0.06 and 10^{-5} mole fractions for H₂O and H⁺, respectively (Ref. 21).

Rapp (Ref. 19) has indicated that Shores and he had found significant proton conduction in highly doped thoria-base electrolytes at 1200-1400 °C. He also referred to work by Kofstad and Norby reporting high proton conduction in yttria. It may well be that this factor will constitute a limitation on use of electrolytes of the CaF₂ type structure or at least require their modification to prevent unacceptable proton transport.

E. AVAILABILITY OF MATERIALS

It is clear that successful anode and electrolyte materials for protective cells of the type envisioned herein will have to meet a number of chemical, physical, mechanical, and electrical properties. Although a sophisticated capability in defect chemistry in ceramics exists for manipulation and control of electrical and transport properties, there will be limitations on what can be done. The most immediately apparent barrier is melting point. A recent review of the literature (Ref. 22) indicates that there are only 38 known oxides with melting points 2250 °C and higher. The number of systems in which to work for capability over 2200 °C is correspondingly limited.

Frequently, as temperatures increase, electronic conductivities of oxygen-ion-conducting electrolytes also increase. There will thus be temperatures beyond which necessary electronic resistance cannot be maintained. This is commonly attributed to activation of electronically conducting thermal defects. Etzell and Flengas (Ref. 23) reporting on work done by Tallan, Bidwell, and Wimmer, suggest that it may be impossible to attain an ionic transference number over 0.99 in thoria-based electrolytes at temperatures over 1400 °C. Similar limitations would be expected in all CaF₂ type structure electrolytes.

It should not be difficult to meet any one requirement for anode or electrolyte materials, e.g., resistivity, coefficient of thermal expansion, etc. However, for the electrolyte, the simultaneous imposition of CTE match with the substrate, chemical compatibility with and adhesion to the substrate, chemical compatibility with the anode

ceramic, an oxygen ion transport number > 0.99 at service temperature, a specific resistance of thousands of ohms at service temperature and a service temperature over 1700 °C constitute a very demanding set of objectives.

IV. CURRENT STATUS, CONCLUSIONS, AND RECOMMENDATIONS

A. CURRENT STATUS

In the technical literature there are many references to work in which an electric potential is applied across a surface oxide on a metal and its effect on oxidation rate observed. However, the surface oxide was invariably the oxide of the substrate, characteristically with high electronic conductivity, low ionic conductivity, or both. Such surface layers are not appropriate electrolytes. With silicon and zinc it was found that the appropriate potential in the right direction did stop oxidation. A conclusion that can be drawn from all of this work is that the oxides of silicon and zinc had ionic and electronic conduction characteristics appropriate for an electrolyte and the the oxides of the other *metals did not*. *No references were found in the literature to any work on electrolytes deliberately selected for their ionic and electronic conduction characteristics.*

Battelle Pacific Northwest Laboratories has now reported the results of brief tests run there under DARPA sponsorship to check the feasibility of electrolytic protection. Zircalloy was selected as the alloy to be protected and electrolytes of stabilized hafnia and stabilized zirconia were applied. The selection of zircalloy was based on familiarity with its oxidation characteristics and the ease of determining the extent of oxidation. A few carbon specimens were run but the results were extraneous since failure proceeded from an uncoated area. In the interest of maximum speed and minimum cost, no attempt was made to characterize the materials used nor to make ancillary measurements which might contribute to a scientific analysis of the test results.

The results of the Battelle work presented in Ref. 4 as shown in Figs. 8 and 9, show a marked acceleration in oxidation rate when the zircalloy substrate is made anodic to the external electrode and a marked reduction in oxidation rate when the substrate is made cathodic. This behavior is predicted theoretically. The potential required to stop oxidation at the 1100 °C test temperature calculated from the free energy of the oxidation reaction is

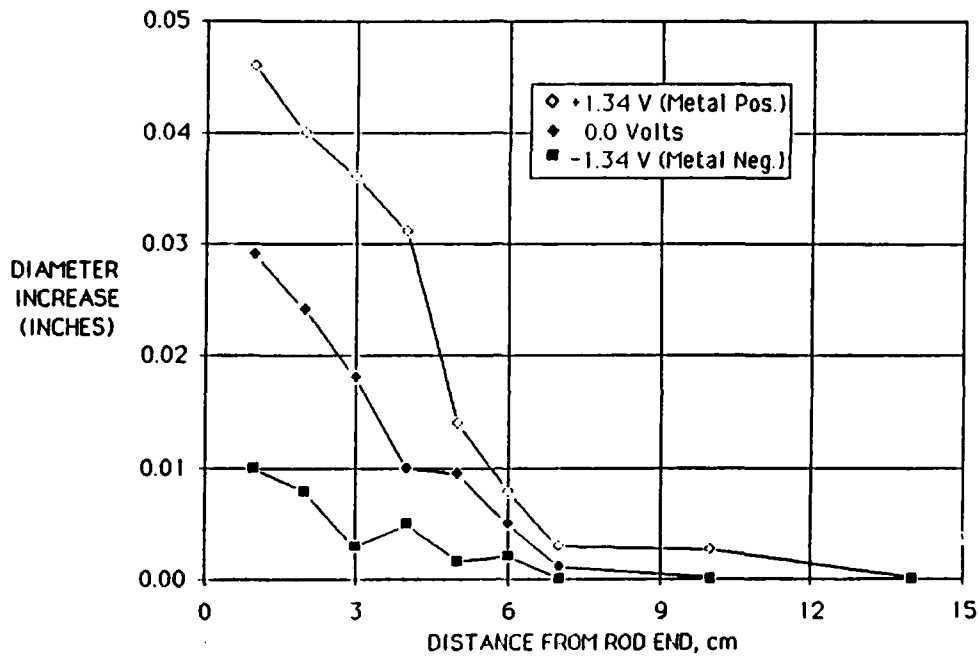

Figure 8. Diameter Increase After 1100 °C/60 min. Plasma Sprayed ZrO_2 *20% Y_2O_3 on Zircalloy. Source: Ref. 24

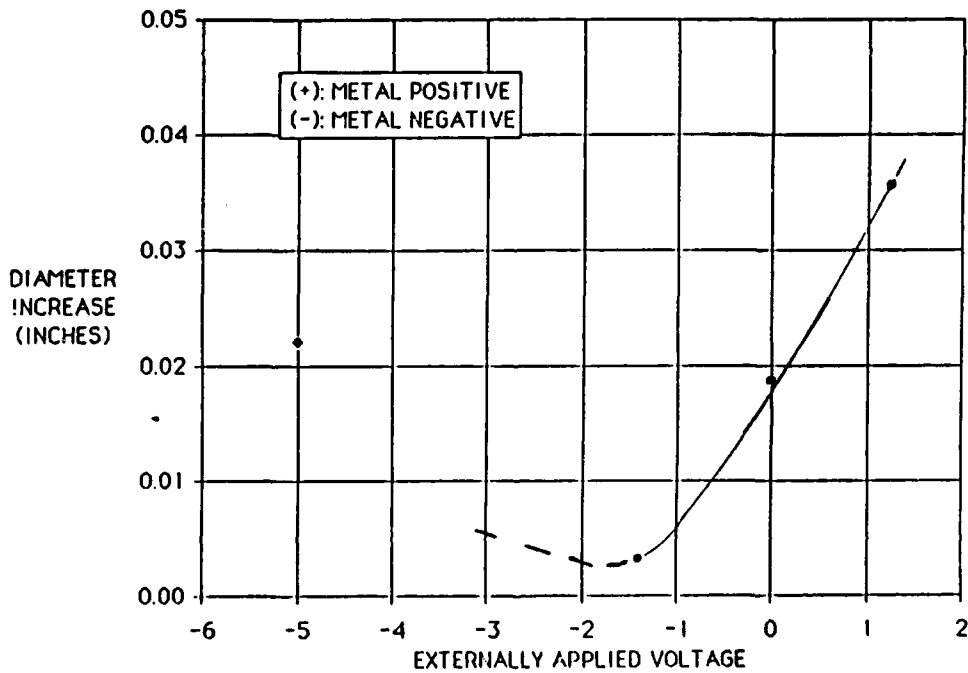

Figure 9. Effect of Applied Voltage on Oxide Growth of Zircalloy at 1100 °C/60 min. Electrolyte: Plasma Sprayed ZrO_2 *20% Y_2O_3 . Source: Ref. 24

about -2.1 V. It is therefore not surprising that the -1.3 V used in the above tests did not stop oxidation completely. There was a minimum in the oxidation rate curves at about -1.3 V. Imposition of more cathodic potentials did not further reduce the oxidation rate and a zero rate of oxidation was not achieved.

Notwithstanding failure to achieve a zero rate of oxidation, the acceleration and deceleration of the oxidation rate with applied potentials clearly indicate the validity of the electrolytic protection principle. The most probable reason for not stopping all oxidation can also be seen from the foregoing presentation. In Fig. 6 it is seen that the limit of the electrolytic domain for stabilized zirconia on the low-pressure side is about 10^{-15} atm of oxygen at 1100 °C. At -1.34 V the oxygen pressure at the zircalloy-electrolyte interface should have been about 4×10^{-21} atm, already six orders of magnitude less than the electrolytic domain. At the -2.1 V required to protect zircalloy, the oxygen partial pressure should have been about 10^{-32} atm. All of the literature references and discussion of conductivity in stabilized zirconia lead one to expect very significant electronic conductivity at such low oxygen pressures. Although there is no requirement other than excessive power demands that electronic conduction be close to zero for electrolytic protection to operate, excessive electronic conduction would mean that the current in the very low oxygen pressure area of the electrolyte would be carried almost entirely by the highly mobile electrons; consequently, the removal of oxygen from that area by ionic conduction would be greatly decreased unless the total current is increased to match the increase in conductivity. This does not occur when only a thin layer of the electrolyte has high electronic conductivity. If, then, the amount of oxygen reaching the substrate area in molecular or atomic form via grain boundaries, cracks, or pores exceeds this counterflow the excess would be available to react with the substrate. In retrospect, zircalloy was probably an unfortunate substrate choice for the Battelle tests because so low an oxygen partial pressure is required to protect it completely, and the limitations of zirconia at very low pressures are widely recognized. The information presented herein would suggest that with zircalloy as the substrate a zero rate might have been achievable with a dual layer electrolyte of the type shown in the sketch on page 22 and a potential of -2.1 V using thoria in the low oxygen pressure region. Alternatively, if the -1.3 V noted in the Battelle tests represents the limit of utility of the zirconia electrolyte, Ir, Ni, Mo, W, Fe, Si, or C should exhibit a zero oxidation rate with the zirconia electrolyte at -1.3 V.

B. CONCLUSIONS

- An electrolytic approach to protection of materials against high-temperature oxidation, described herein, is theoretically sound and is supported by limited experimental work on silicon, zinc, and zircalloy.
- In view of the broad military significance of improved oxidation resistance in the refractory metals and carbon and of the very limited number of approaches for attaining such improvement, the electrolytic protection approach to this objective is worthy of further exploration and development.
- A series of potential limitations and difficulties in applying electrolytic protection are recognized, but none of these as yet disqualify the approach or necessarily restrict development of a protection capability well above that now in existence.

C. RECOMMENDATIONS

- A significant but not major size R&D program should be undertaken on materials and application techniques for electrolytic protection of the refractory metals and carbon against high-temperature oxidation.
- The R&D effort should contain a strong element of characterization of the materials involved to permit definitive rationalization of test results. Emphasis should be placed on determination of electronic and ionic conductivities versus temperature and oxygen pressure, impurity effects, transference numbers, diffusion modes and rates, thermal expansion characteristics, interface reactions, stability, and resistance to service environments.

V. REFERENCES

1. M.G. Fontana, N.D. Greene, *Corrosion Engineering*, McGraw-Hill Book Company, New York, 1978, p. 207.
2. P. Kofstad, *High Temperature Oxidation of Metals*, John Wiley & Sons, New York, 1956, p. 112.
3. T.P. Hoar and L.E. Price, *Trans. Faraday Soc.*, **34**, 1938, p. 867.
4. P.J. Jorgensen, *J. Chem. Phys.*, Vol. 37, No. 5, 1962, p. 874.
5. P.J. Jorgensen, "Oxidation of Metals and Alloys", *ASM Seminar*, October 1970, p. 157.
6. P.J. Jorgensen, *J. Electrochem. Soc.*, Vol. 110, May 1963, p. 461.
7. V. Ananth, S.C. Sircar, S.K. Bose, *Trans. Japan Inst. Metals*, Vol. 26, No. 2, 1985, pp. 123-133.
8. *Handbook of Chemistry and Physics*, Chemical Rubber Publishing Co., 68th Edition, CRP Press Inc., Boca Raton, FL.,
9. W.L. Worrell, "Oxide Solid Electrolytes," in *Topics in Applied Physics*, Vol. 21, *Solid Electrolytes*, Editor S. Geller, Springer Verlag, Berlin, Heidelberg, 1977.
10. I. Bransky and N.M. Tallan, *J. Am. Ceram. Soc.*, Vol. 53, 1970, p. 625.
11. J.W. Patterson, *J. Electrochem. Soc.*, Vol. 118, 1971, p. 1033.
12. J. Rudolph, *Z. Naturforsch.*, Vol. A14, 1959, p. 727.
13. J.E. Bauerle, *J. Chem. Phys.*, Vol. 45, 1966, p. 4162.
14. M.F. Lasker and R.A. Rapp, *Z. Phys. Chem., N.F.*, Vol. 49, 1966, p. 198.
15. N. Tallan, *Electrical Conductivity in Glass and Ceramics*, Dekker, 1974.
16. E. Courtright, Battelle Northwest Pacific Laboratories., private communication, 15 October 1986.
17. Hagenmuller and VanGool, *Solid Electrolytes, General Principles, Characterization, Material and Applications*, Academic Press, 1978.

18. D.P. Partlow, W.R. Brose, C.A. Andersson, *Exploratory Development of Reinforced Ceramic Electromagnetic Transparencies*, AFWAL, TR-85-4152, April 1986.
19. R.A. Rapp, Ohio State University, private communication, 3 September 1986.
20. J.F. Stringer, *High Temperature Corrosion of Aerospace Alloys*, AGARD-AG-200, Advisory Group for Aerospace Research and Development, NATO, Paris, France, 1975.
21. E.F. Wilks, LTV ltr 2-34500/3L-6276, 27 September 1983 to R.R. Stalder, ASD/XRZ, Advance Review Material, Fifth Bi-Monthly Program Review, ELITE Program.
22. R.L. Fleischer, "High Temperature, High Strength Materials - An Overview", *J. of Metals*, December 1985, pp. 16-20.
23. T.H. Etsell, S.N. Flengas, *Chem. Rev.*, Vol. 70, No. 3, 1970, p. 364.
24. E.L. Courtright, C.H. Henager, Jr., R.W. Knoll, *An Evaluation of Electrolytic Protection as a Concept to Prevent High Temperature Oxidation*, Battelle Pacific Northwest Laboratories draft report to Materials Sciences Office, DARPA, October 1987.

APPENDIX

SENSITIVITY TO ELECTRICAL RESISTANCES

APPENDIX

SENSITIVITY TO ELECTRICAL RESISTANCES

Although the ceramic materials that might be used as electrode layers in coatings that might form electrolytic protection cells of the type described in the paper may have good specific electrical conductivity compared to other ceramics, they are not good compared to most metals. In addition, because the electrode layers will be thin, their electrical resistance per unit width in the direction of current flow, i.e., ρ/t where ρ is specific resistance, and t is thickness, may be appreciable. Rather than flowing along its length, current through the electrolyte will be predominantly through its thickness so that, even though the electrolyte ceramic may have relatively high specific resistance, its resistance per unit area in the direction of current flow, i.e., ρt , may be quite low.

In addition to appreciable resistances where low resistance is desired and low resistance where high resistance is desired, the ceramic materials will vary in resistance with temperature. In contrast with metals which increase in resistance with temperature, the oxide ceramics generally decrease in resistance as temperature increases, see Figs. 5 and 7 in the main text. Electrode ceramic specific resistances in hundredths of $\Omega\text{-cm}$'s and electrolyte specific resistances in the thousands of $\Omega\text{-cm}$'s are the general ranges likely to be encountered initially.

As a means of examining the sensitivity of the electrolytic protection procedure to the electrical resistances of the components of the electrolytic cell, voltage drops, current distribution and power in the simple specimen shown in Fig. A-1 were analyzed using the simple $E = IR$ relationship. This was intended to represent something like a turbine vane in which there is a center area (zones 4,5,6, and 7) at a uniform high temperature which decreases uniformly to colder ends where electrical connections might be made. The 10-cm length is reasonable for a small engine vane which might also have a circumference of about 10 cm. The 1-cm specimen width is merely unit width. The analysis was made by assuming a circuit of 10 paths in parallel which vary in resistance, depending on the layer thicknesses and specific resistances assigned.

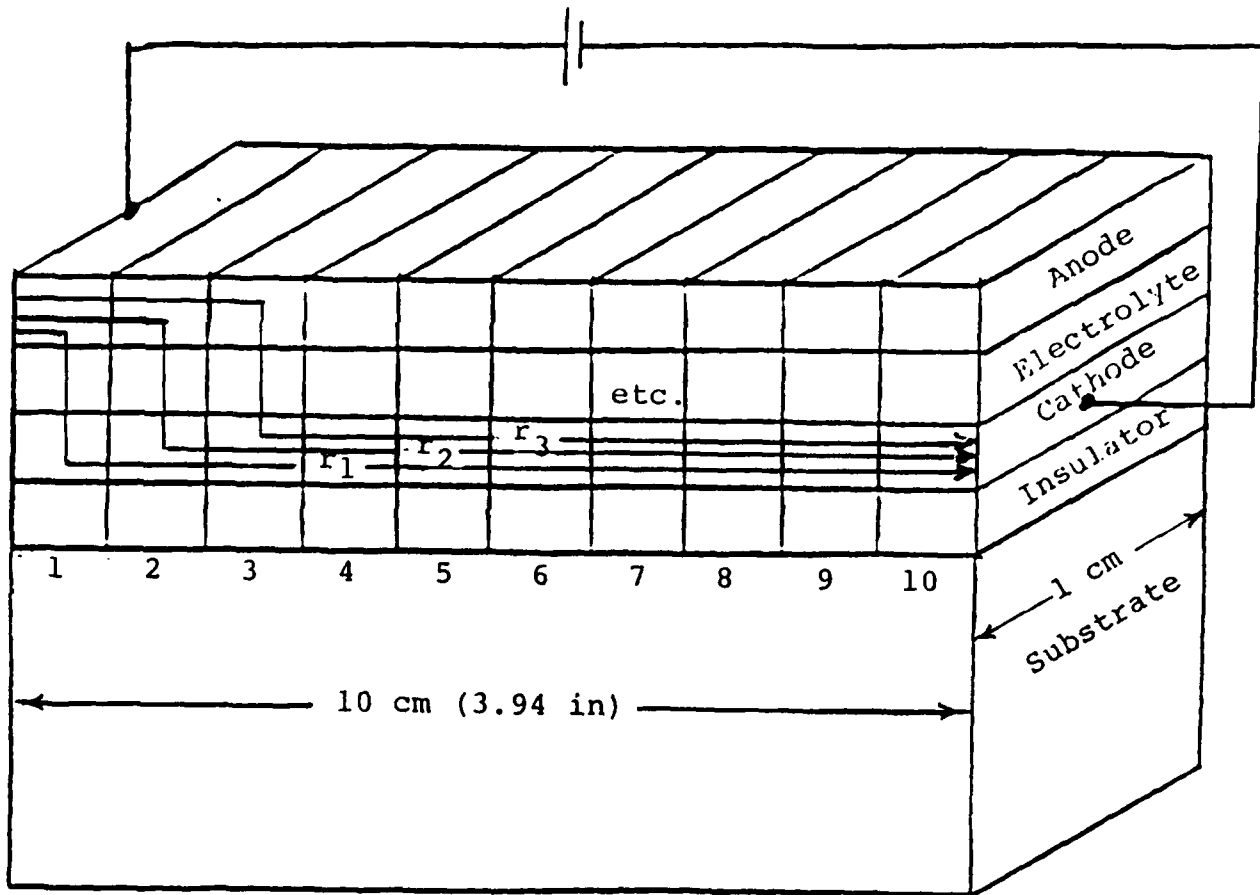

Figure A-1. Specimen for Voltage Calculation.

The externally applied voltage was adjusted to give the desired protection potential across the electrolyte at point 4, and the resulting currents and voltages elsewhere and total power were calculated.

- A specimen of two coating layers, each 0.002" thick on a substrate niobium alloy vane 3/16 in. thick with a protecting potential 1.5 V was assumed to have low- and high-temperature specific resistances, respectively, of 0.01 and 0.009 Ω -cm for the anode, 4000 and 1000 Ω -cm for the electrolyte and 1×10^{-5} and 2×10^{-5} Ω -cm for the cathode substrate. Voltages across the electrolyte along the specimen length were 3.2 at 1, 1.5 at 4, 1.0 at 7, and 1.7 at 10. It is apparent that the great disparity in conductivity between the metal substrate and ceramic anode is the principal reason for the wide voltage variations.
- A specimen, as in Fig. A-1, of three coating layers, each 0.002" thick, forming an electrolytic cell insulated from the substrate with a protecting potential of 1.5 V, was assumed to have low- and high-temperature resistances, respectively, of 0.01 and 0.009 for both the anode and ceramic cathode and 4000 and 1000 Ω -cm for the electrolyte. The substrate here was not part of the electrical circuit. Voltages across the electrolyte along the specimen length were 3.4 at 1, 1.5 at 4 and 7, and 3.4 at 10. They are now uniformly correct in the hot zone but rise objectionably, symmetrically toward the cold ends. Power demand at 175 W per vane was too high.
- Raising the cold and hot specific resistances of the electrolyte from 4000 and 1000 Ω -cm to 12,000 and 3000 Ω -cm, respectively, reduces power demand from 175 to 25 W per vane and the end voltages from 3.4 to 2.5 V. Voltages are still uniformly correct in the hot zone at 1.5.
- If, now, the thicknesses of the anode, cathode, and electrolyte layers are varied as the resistances vary with temperature, keeping resistance/thickness constant for anode and cathode and keeping resistance times thickness constant for the electrolyte current and voltage, variations disappear for this symmetrical specimen, i.e., potential drop is uniform at 1.5 V across the electrolyte from end to end. Layer thicknesses can be varied as long as the ratios for anode and cathode and the product for the electrolyte are held constant. Temperature, resistance, thickness, and voltage profiles are as shown in Fig. A-2.

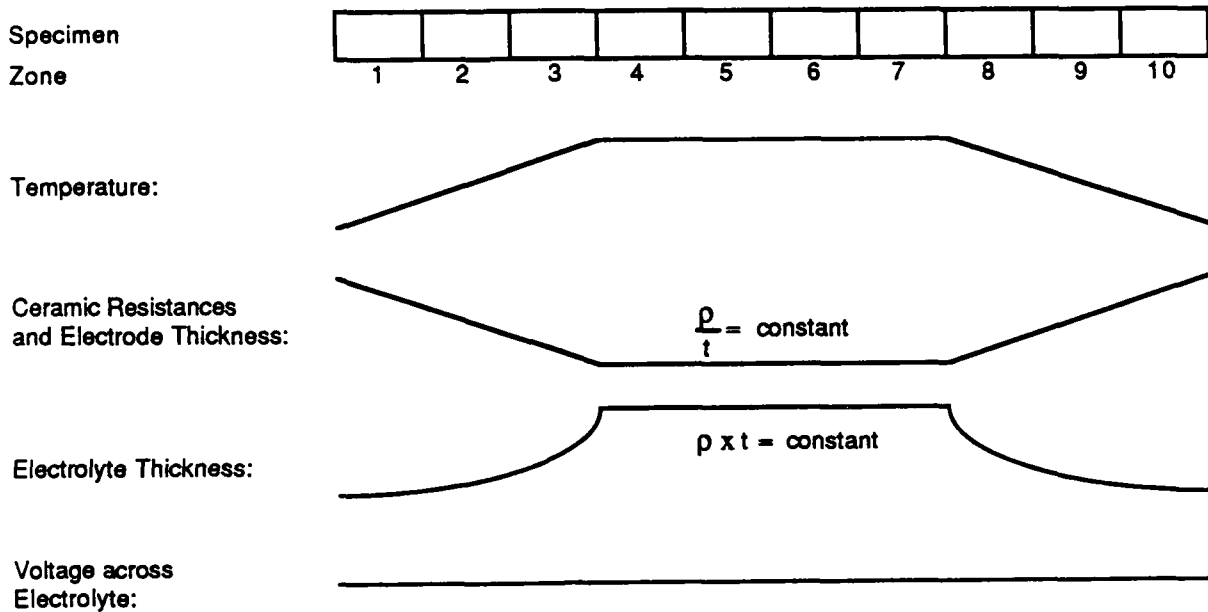

Figure A-2. Temperature, Resistance, Thickness, and Voltage Profiles

In any specific application, it will be necessary to arrange current paths to insure that the potential drop across the electrolyte is correct in the various locations on the part. On a part such as a turbine vane, illustrated by the Williams International test specimen shown in Fig. A-3, the distance from the flat outside end surfaces to corresponding parts of the concave and convex blade surfaces varies due to blade curvature, implying differences in electrical resistances. It may be possible to compensate for such shape-controlled variations by shaping metallic connections as illustrated in Fig. A-4. Here, the distances are the same from the outside edges of the cross-hatched contact to corresponding points on the concave and convex blade surfaces. Undoubtedly there will be parts in which no amount of design ingenuity will afford the necessary voltage control.

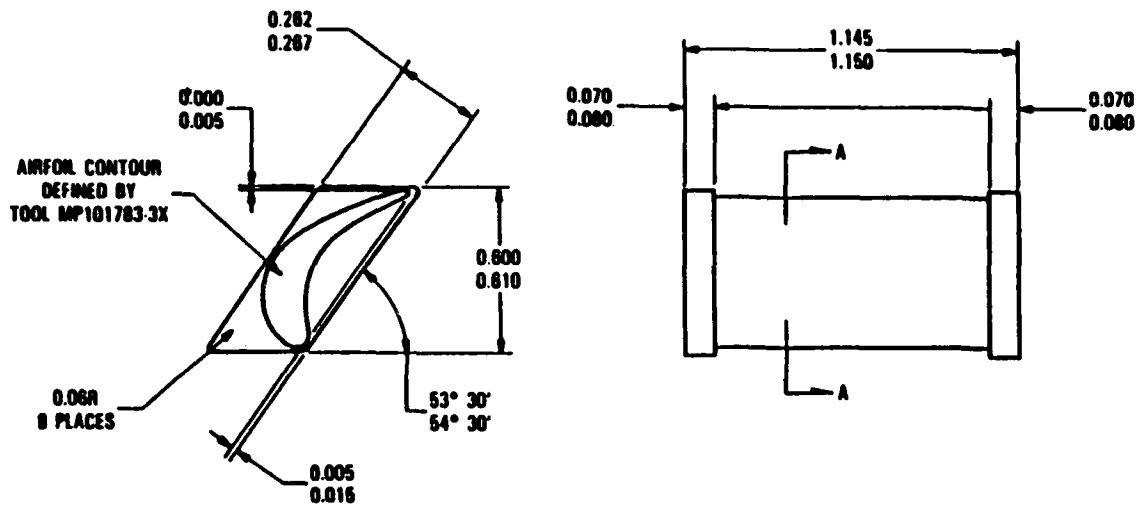

Figure A-3. Combustor Rig Vane Specimen Geometry

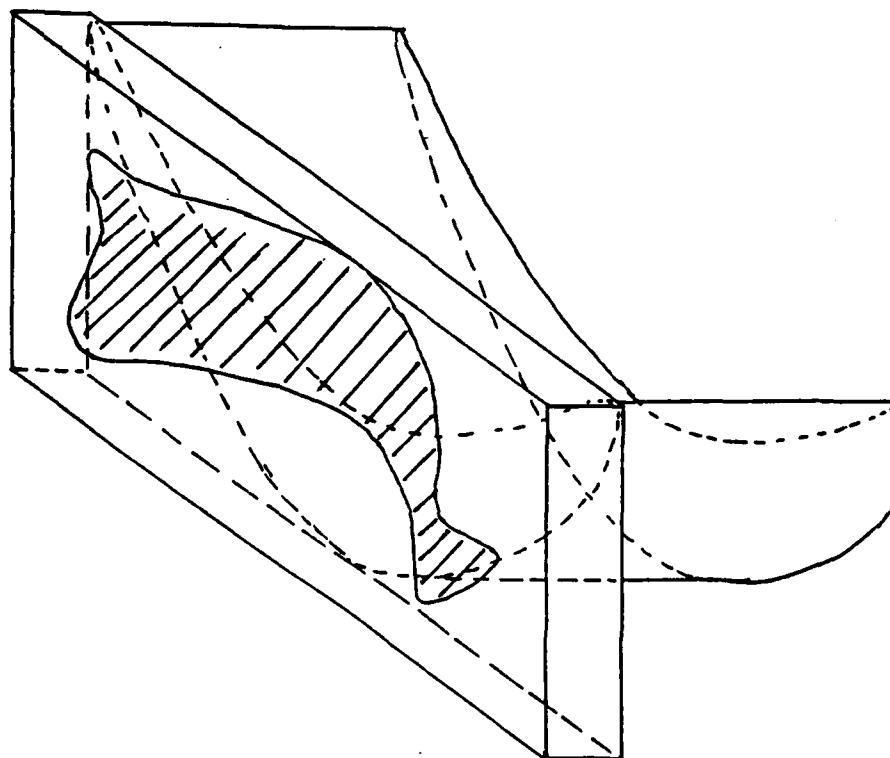

Figure A-4. Compensating Contact Surface