

DTIC FILE COPY

4

MRL-GD-0019

AR-005-656



AD-A204 963

**DEPARTMENT OF DEFENCE**  
**DEFENCE SCIENCE AND TECHNOLOGY ORGANISATION**  
**MATERIALS RESEARCH LABORATORY**  
**MELBOURNE, VICTORIA**  
**GENERAL DOCUMENT**

MRL-GD-0019

**INTERLOCKING SAFETY PROCEDURES FOR HIGH EXPLOSIVE PRESSING  
FACILITY AT MATERIALS RESEARCH LABORATORY**

M. Coxhead and R. Czigledy

DTIC  
ELECTE  
28 OCT 1989  
S D  
OSE

Approved for Public Release



SEPTEMBER 1988

89 2 29 013

DEPARTMENT OF DEFENCE  
MATERIALS RESEARCH LABORATORY  
GENERAL DOCUMENT  
MRL-GD-0019

INTERLOCKING SAFETY PROCEDURES FOR HIGH EXPLOSIVE PRESSING  
FACILITY AT MATERIALS RESEARCH LABORATORY

M. Coxhead and R. Czigledy

ABSTRACT

The Explosives Division Explosives Pressing Facility operates three presses requiring close or remote and extended period pressing modes. The safety interlock requirements for the facility are discussed and the means of providing them are described.

*... safety ...*



Approved for Public Release

© Commonwealth of Australia

Accession For	
NTIS GRA&I	<input checked="" type="checkbox"/>
DTIC TAB	<input type="checkbox"/>
Unannounced	<input type="checkbox"/>
Justification	
By _____	
Distribution/	
Availability Codes	
Dist	Avail and/or Special
A-1	

POSTAL ADDRESS: Director, Materials Research Laboratory  
P.O. Box 50, Ascot Vale, Victoria 3032, Australia

## CONTENTS

	Page No.
1. INTRODUCTION	1
2. PRESSING FACILITY	1
2.1 <i>Isostatic Press</i>	1
2.2 <i>Upstroking Press</i>	2
2.3 <i>Ten Tonne Press</i>	2
3. OPERATING MODES	2
3.1 <i>System Control</i>	2
3.2 <i>Isostatic Press</i>	2
3.3 <i>Upstroking Press</i>	3
3.4 <i>Ten Tonne Press</i>	3
4. GENERAL LAYOUT OF PRESSING FACILITY	3
4.1 <i>Pressing Bay</i>	3
4.2 <i>Preparation Bay</i>	3
4.3 <i>Plant Room</i>	4
4.4 <i>Control Room</i>	4
5. INTERLOCKING	4
5.1 <i>Requirements</i>	4
5.2 <i>Safety Interlocks</i>	5
5.2.1 <i>Close Control</i>	6
5.2.2 <i>Remote Control</i>	6
5.3 <i>Interlock (Sensor) By-pass</i>	6
6. OPERATING PROCEDURES	6
7. CONCLUSION	7
APPENDIX A - <i>Procedures for Selectable Interlocked Pressing Operations</i>	8

INTERLOCKING SAFETY PROCEDURES FOR HIGH EXPLOSIVES  
PRESSING FACILITY AT MATERIALS RESEARCH LABORATORY

1. INTRODUCTION

Explosives Division of MRL is establishing an Explosives Pressing Facility. The operation of the presses is controlled by a personal computer (PC) based system (IBM XT) and a separate microprocessor, enabling pre-defined remote and close controlled pressing to be performed.

Pressing and setting up operations have to be carried out under strict control enforced by a safety interlocking system. This report describes the operations to be controlled and the system devised to satisfy the requirements.

2. PRESSING FACILITY

The high explosives pressing facility consists of two existing presses and a third to be designed and installed, a control room, mould preparation room and a plant room (Fig. 1).

**2.1 Isostatic Press**

This press will be used for preparing explosives compacts by applying uniform (isostatic) pressure to all external surfaces of the material being pressed. The material is placed into a sealed "bag" which in turn is located in the press chamber which is 130 mm diameter and 275 mm long and is designed for a maximum operating pressure of 210 MPa. The press is filled with oil and the required compacting pressure applied. It is shown in Plate 1.

## 2.2 Upstroking Press

This is a four column hydraulic press with a fixed upper and a moving "upstroking" lower platten. It is capable of producing platten closing forces of up to 100 tonne and is designed to accommodate pressing moulds that can produce compacts up to 150 mm diameter and 150 mm long (Plate 2).

## 2.3 Ten Tonne Press

Yet to be designed, this press will cater for those pressing operations unable to be carried out satisfactorily on the other presses. In due course it is planned that a semi-automatic mould feeding and pellet extracting system will be incorporated.

# 3. OPERATING MODES

## 3.1 System Control

The control of the presses is by a microprocessor and personal computer. The microprocessor's read only memory (ROM) controls the critical operations designated by the PC input. In the event of failure of the control system, deviation from selected parameters (indicated by sensor mismatch), power failure or interlock interruption, the system will automatically close down to a safe mode. In the event of system shut down the hydraulic system will hold "status", thereby allowing investigative procedures to be implemented before system start up procedures are initiated. Press control is on a mutual exclusion basis, ensuring that only one press is operating at a time.

Each of the three presses has differing operating modes which must have software and mechanical interlocking for each of its control functions. The interlocking must ensure that there is no possibility of damage to personnel and equipment except if caused by a deliberate calculated action.

## 3.2 Isostatic Press

This press consists of a high pressure vessel, an oil reservoir, pressure intensifier, air controlled valves and associated "plumbing". The low pressure (0-21 MPa) oil supply is provided by the hydraulic supply system common to the three presses. The low pressure oil is used to operate the "oil to oil" pressure intensifier (pneumatically controlled) to achieve the required chamber pressure which has an upper limit of 210 MPa. This press is only permitted to operate under remote control and the only close operations are the loading and unloading of moulds via the threaded closure block when at zero pressure. Manipulation of control parameters is only possible using the PC.

### **3.3 Upstroking Press**

The four column upstroking platten press uses the 0-21 MPa oil supply for its operation. It can be used to press to a preset load or to an adjustable stop and has remote and close control operating modes. A close control console, suitably interlocked, is provided to enable proving of mould set up under restricted conditions.

During "set-up" operations, pressure and closing rate are limited by the software in the PC and manipulated to those maximum limits from the Close Control Panel adjacent to the press. Pressure is limited to a maximum of 300 kPa and speed of travel is limited to a maximum of 0.0025 m/s. These limits of pressure and speed allow the operator to adjust tooling stops to ensure correct alignment of mould assemblies, thereby preventing any damage to expensive moulds.

### **3.4 Ten Tonne Press**

The configuration of this press is not yet finalized. However it is expected to be a vertical, downward-acting ram variety and will be supplied by the 0-21 MPa hydraulic system.

## **4. GENERAL LAYOUT OF PRESSING FACILITY**

The high explosives pressing facility is arranged in 4 Bays with each having its own dedicated function (Fig. 1).

### **4.1 Pressing Bay**

The presses are located within cells separated by blast walls and only those sensors and operating systems required to be connected to the presses and moulds are contained within the bay. No loose explosive will be allowed in this bay.

### **4.2 Preparation Bay**

A preparation bay is located alongside the pressing bay for the purpose of loading and assembling mould and ram or, in the case of the Isostatic Press, the preparation and loading of sealed moulds. Following assembly the appropriate moulds are transferred to the pressing bay for the pressing operation.

#### **4.3 Plant Room**

A plant room is located behind the pressing bay and contains a hydraulic pump, valves, hot water heater and other ancillary equipment of the presses. Connections to the control room and pressing bay are made via ducts through the walls. This bay will always be free from explosive contamination thus enabling maintenance to be carried out without the need for time consuming cleaning and "Clear of Explosives" certification.

#### **4.4 Control Room**

The control room is located behind the preparation bay and has been reinforced to protect operators from an explosive incident. This room controls the operation of the pressing bay and a remote-controlled explosives breakdown bay, which is independent of this subject and operates on a mutually exclusive basis with the pressing facility.

### **5. INTERLOCKING**

#### **5.1 Requirements**

The control system of the pressing facility is required to operate three explosives presses located in cells within the same bay. Each press has its own peculiar operating mode/s which have to be satisfied in order to complete the required operation.

The operation of the isostatic press is remote only, however the upstroking press has a close controlled "set up" and remotely controlled "pressing" mode. The ten tonne press will have both close and remotely operated modes determined by the quantity of explosive handled. In addition an "extended" pressing period is required for all three presses; this can extend to hours. Divisional policy requires that facilities of this type be protected by a physical interrupt safety key interlock system.

The operating modes of the presses have been previously described in Section 3. Positive and unmistakable mode selection methods must be provided. Close control and setting up operations require that the operators leave the control room after initiating a particular press and enter the pressing bay to carry out an operation. Control room and pressing bay interlocks have to be provided and the operating mode must be selected in the control room then verified from the press.

Unauthorised entry to the pressing facility during operation must be prevented. Sensor coupled boom barriers located in the access corridors and a flashing red light satisfy this requirement. Attempted unauthorised entry must result in the safe shut down of the system.

The pressing facility is designed for experimental work which can include the study of the effect of long term compacting of explosives. This can include pressing

operation extending to a number of hours. A provision has been made for the operators to leave the control room after the elapse of a predetermined safety period and to return during or after the extended pressing cycle. The safety period is software controlled and is set to allow initial consolidation of the explosive material. This is deemed to be a high risk period. The elapse of the safety period is indicated by a prompt on the PC screen and must be acknowledged by the operator. If this is not carried out within one minute then the system is shut down. A method of bypassing and reinstating the control room and barrier sensors (interlocks) has to be provided.

From the foregoing it can be seen that the following operations need independently addressable interlocking systems.

- (a) Remote operation of the Isostatic Press.
- (b) Remote operation of the Upstroking (100 tonne) Press.
- (c) Close controlled operation of the Upstroking Press in the "set up" mode.
- (d) Remote operation of the 10 Tonne Press.
- (e) Close controlled operation of the 10 Tonne Press.
- (f) Departure/return of operators from/to the control room independent of the remote pressing cycle.

A Safety Fault Tree logic diagram for each of the above operations was prepared. These are shown in Figures 2 to 7.

## 5.2 Safety Interlocks

The interlocking system has been designed to satisfy requirements of the logic diagrams incorporating all of the elements and to be logically interpreted and used. "Castell Lock" systems of mechanical/electrical interlocking type are used in these applications within MRL. A catalogue of assigned keys is maintained and duplication of keys is avoided. The system was adopted for the key operated safety interlocking of the pressing facility. The "Castell Lock" system is shown in Fig. 8 and contains the minimum number of key units that will satisfy the requirements of the fault tree diagrams. There are four operation selecting control keys and each is mutually exclusive, all have inputs to the PC thus initiating the programme for a particular press (2P, or 3P, or 4P, or 5P).

Entry points to the area are controlled by boom barriers which will, if violated, cut power to the system which will shut down as described in 3.1. The existing microswitch located on the control room door provides a safety interlock for the breakdown facility and is incorporated in the interlocking system.

At any one time only one press may be operated. System manipulation is determined by two distinct actions, one being "Castell Key" selection, the other is software selection; wrong selection of either will not enable the system. There are two

operating modes, remote and close control. These are operator determined by software and "Castell Keys".

### 5.2.1 Close Control

This mode enables the operator to manipulate either the upstroking or the ten ton press within predetermined limits and allows access to the press bay. It does not allow operation of the isostatic press.

### 5.2.2 Remote Control

In the remote mode the selected press may only be operated from the control room. The press can be used at any load selected; attempted entry to the press bay will cause the pressing cycle to be aborted, the load fully removed and the ram to be held in position. For remote operations the system must ensure that pressing operations can not be commenced before the booms and doors are closed and the operators are in the control room. Provision is made for the operator to leave and re-enter the facility during extended pressing operations.

### 5.3 Interlock (Sensor) By-pass

For close control operations the control room door interlock has to be by-passed to enable entry to the press bay and press control to be established from the "close control" panel adjacent to the press. The interlock key on the panel confirms with the computer that close control operation is about to commence and it then permits operations within the preset parameters. The "C" series keys (Fig. 8) are used to achieve this. The sequence is described in sections 2.2 (iii)-(vi) and 3.2 (iii)-(vii) of Appendix A.

Personnel exit/entry from/to the facility during extended pressing operations is enabled by using the "E" series keys as detailed in sections 1.1, 2.1 and 3.1 (v)-(x) of Appendix A.

The electrical schematic diagram for the by-pass switching is shown in Fig. 9.

## 6. OPERATING PROCEDURES

Start up of the operating system is achieved by loading the press calibration and control programmes into the PC, unlocking the master selector using key 1P and then turning the master selector to the desired operation:

- (a) "remote isostatic or upstroking press"
- (b) "close upstroking press"
- (c) "remote 10T press" or
- (d) "close 10T press".

Each of these four positions enables the release of two keys required to complete the selected operation. The first key is used, via an electrical connection, to select the appropriate part of the PC programme. The second key, depending on the operation, is used as the first step in a chain of mechanical and electrical interlocks to enable close control operations or exit from and re-entry to the facility during extended time operations. The schematic of the interlocking system using "Castell Key" elements is shown in Fig. 8 and is referred to in Appendix A which describes in detail the procedure for each pressing operation.

## 7. CONCLUSION

The task of providing a mechanical/electrical Safety Interlock System for the MRL High Explosives Pressing Facility was achieved using "Castell Key" units. The system devised enables the safe, mutually exclusive, operation of three presses within the same bay and provides selectable close and remote operating modes for two of the presses. It also caters for extended time pressing operation by permitting the operator to leave and re-enter the facility without it being shut down.

The system was discussed with and approved by the MRL Explosives Safety Advisory Panel.\* The system has been installed and shown to meet all imposed requirements.

---

\* MRL Explosives Safety Advisory Panel, Minutes of the 93rd Meeting (12 September 1986).

## APPENDIX A

### PROCEDURES FOR SELECTABLE INTERLOCKED PRESSING OPERATIONS

The operating procedures for the presses are detailed on the following pages. The keys referred to are shown in the schematic of the interlocking system (Fig. 8).

#### 1. ISOSTATIC PRESS

##### 1.1 Remote

- (i) Press selected, programme activated (PC functions), press loaded (mould inserted).
- (ii) Select key 2P (programme confirmed).
- (iii) Pressing commenced (operator/PC input).
- (iv) After predetermined elapsed time PC prompt and operator to cancel thereby confirming presence, operator free to depart area.
- (v) To exit, remove key EP.
- (vi) Exchange key EP for key E1. Door and boom by-passed.
- (vii) Proceed through door and boom, closing behind.
- (viii) Exchange key E1 for key E2 thereby removing by-passes, area again secure.
- (ix) Operator maintains custody of key or returns it to Officer-in-charge for safe keeping.
- (x) Re-entry to the facility is achieved by reversing the above steps.

The press will complete its pressing cycle and download accordingly or before if secure area is violated.

##### 1.2 Close control

Not possible.

#### 2. UPSTROKING PRESS

## **2.1 Remote**

- (i) Press selected, programme activated (PC functions), press loaded (mould inserted).
- (ii) Select key 2P (programme confirmed).
- (iii) Pressing commenced (operator/PC input).
- (iv) After predetermined elapsed time PC prompt. Operator to cancel thereby confirming presence, operator free to depart area.
- (v) To exit, remove key EP.
- (vi) Exchange key EP for key E1. Door and boom by-passed.
- (vii) Proceed through door and boom, closing behind.
- (viii) Exchange key E1 for key E2 thereby removing by-passes, area again secure.
- (ix) Operator maintains custody of key or returns it to Officer-in-charge for safe keeping.
- (x) Re-entry to the facility is achieved by reversing the above steps.

The press will complete its pressing cycle and download accordingly or before if secure area is violated.

## **2.2 Close Control**

- (i) Press selected, programme activated (PC functions), press loaded (mould inserted).
- (ii) Select key 3P (programme confirmed).
- (iii) Remove key CP.
- (iv) Exchange key CP for key C1 (door sensor disabled).
- (v) Insert key C1 into pressing bay door lock, unlock door, exchange for key C2.
- (vi) Insert key C2 into Close Control Panel (local control enabled, programme re-confirmed).
- (vii) Operation within predetermined limits allowed for mould proving.

### 3. 10 TONNE PRESS

#### 3.1 Remote

- (i) Press selected, programme activated (PC functions), press loaded (mould inserted).
- (ii) Select key 4P (programme confirmed).
- (iii) Pressing commenced (operator/PC input).
- (iv) After predetermined elapsed time PC prompt. Operator to cancel thereby confirming presence, operator free to depart area.
- (v) To exit, remove key EP.
- (vi) Exchange key EP for key E1. Door and boom by-passed.
- (vii) Proceed through door and boom, closing behind.
- (viii) Exchange key E1 for key E2 thereby removing by-passes, area again secure.
- (ix) Operator maintains custody of key or returns it to Officer-in-charge for safe keeping.
- (x) Re-entry to the facility is achieved by reversing the above steps.

The press will complete its pressing cycle and download accordingly or before if secure area is violated.

#### 3.2 Close Control

- (i) Press selected, programme activated (PC functions), press loaded (mould inserted).
- (ii) Select key 5P (programme confirmed).
- (iii) Remove key CP.
- (iv) Exchange key CP for key C1 (door sensor disabled).
- (v) Insert key C1 into pressing bay door lock, unlock door, exchange for key C2.
- (vi) Insert key C2 into exchange box and remove key C3.
- (vii) Insert key C3 into Close Control Panel (local control enabled, programme re-confirmed).
- (viii) Operation within predetermined limits allowed for HE pressing.

The design of the tooling for this press will determine the maximum quantity allowed to be pressed in close control mode.

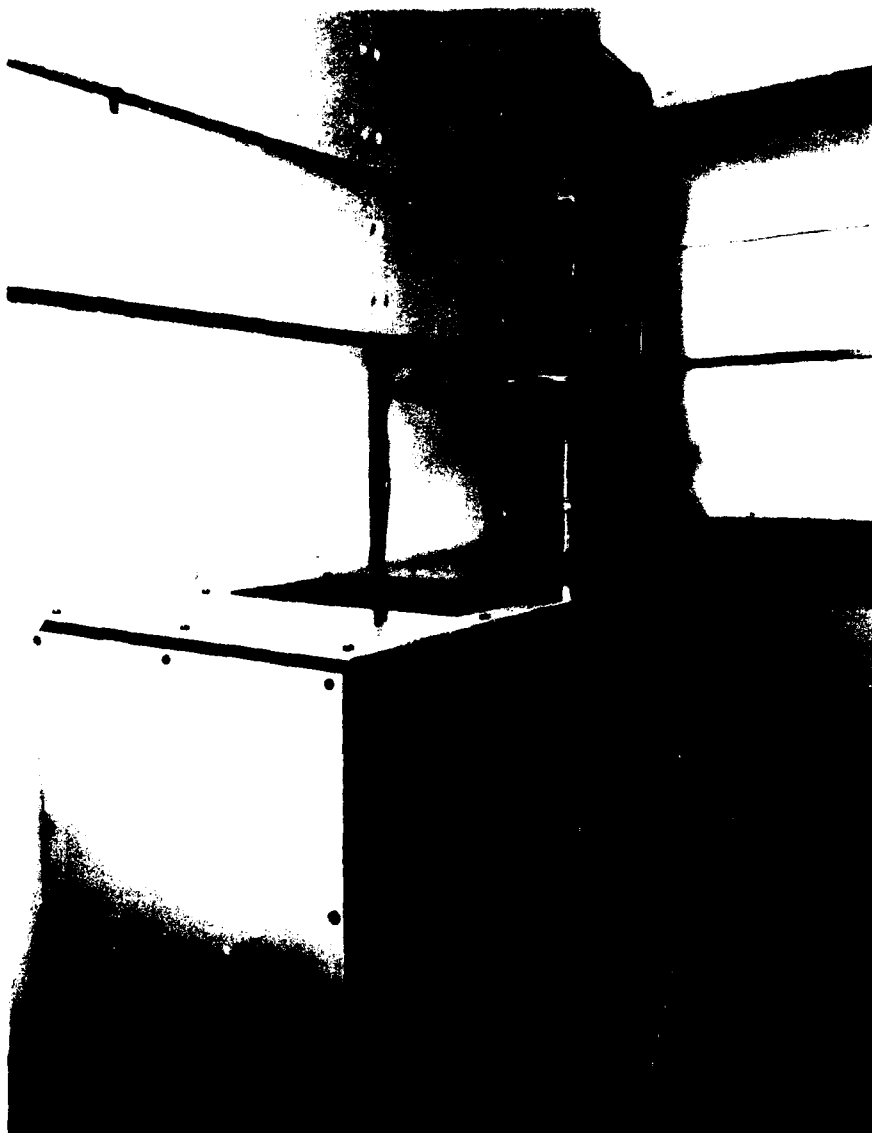

**PLATE 1 ISOSTATIC PRESS**

**Showing jacketed chamber, pressure intensifier and closure  
plug ready for insertion.**

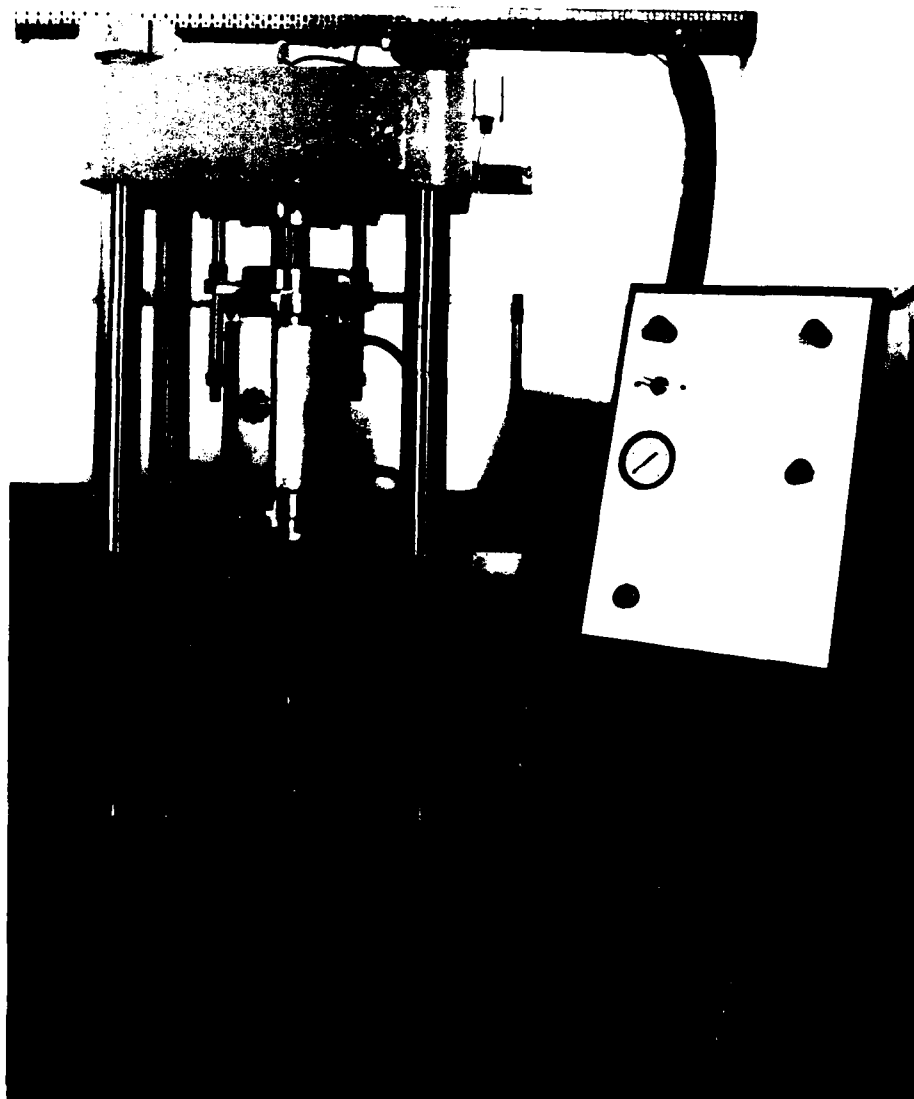

**PLATE 2 UPSTROKING PRESS**

**With 150 mm mould and close control panel.**

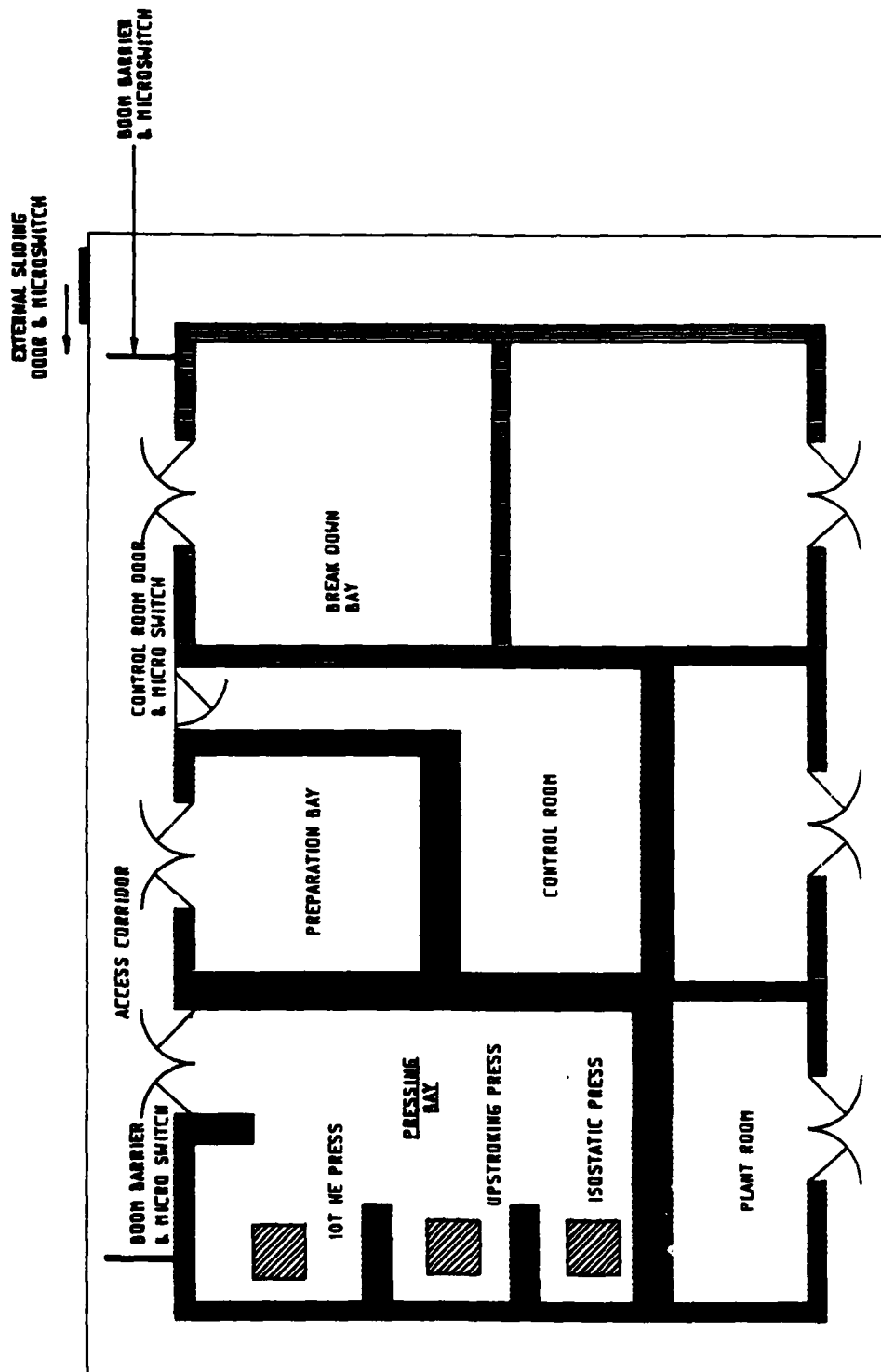

FIGURE 1 Layout of Pressing Facility

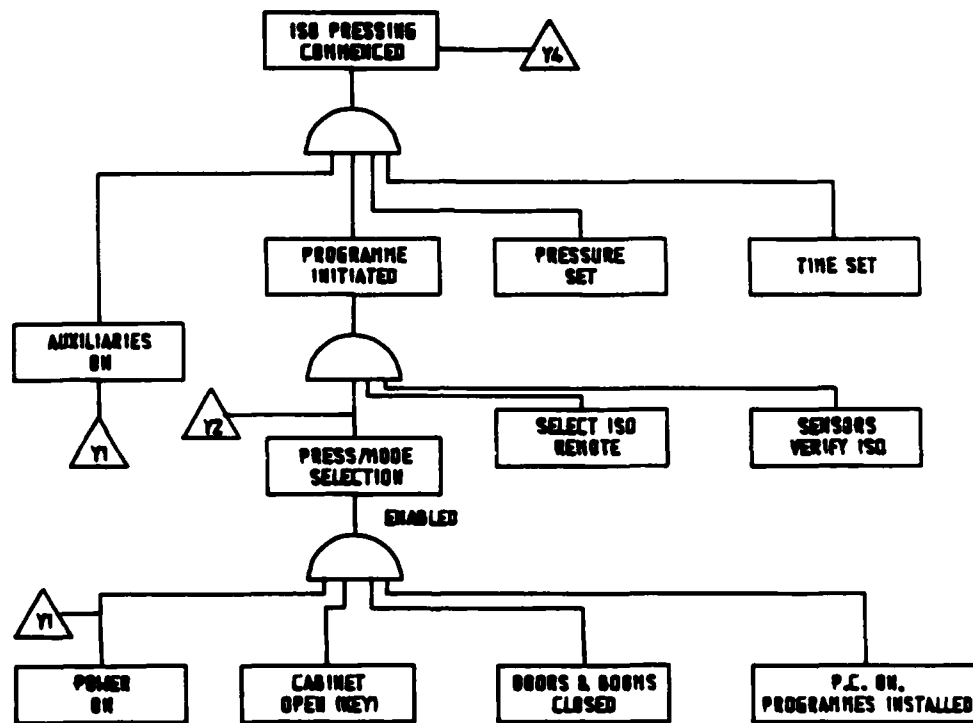

FIGURE 2 Safety Fault Tree for Isostatic Press



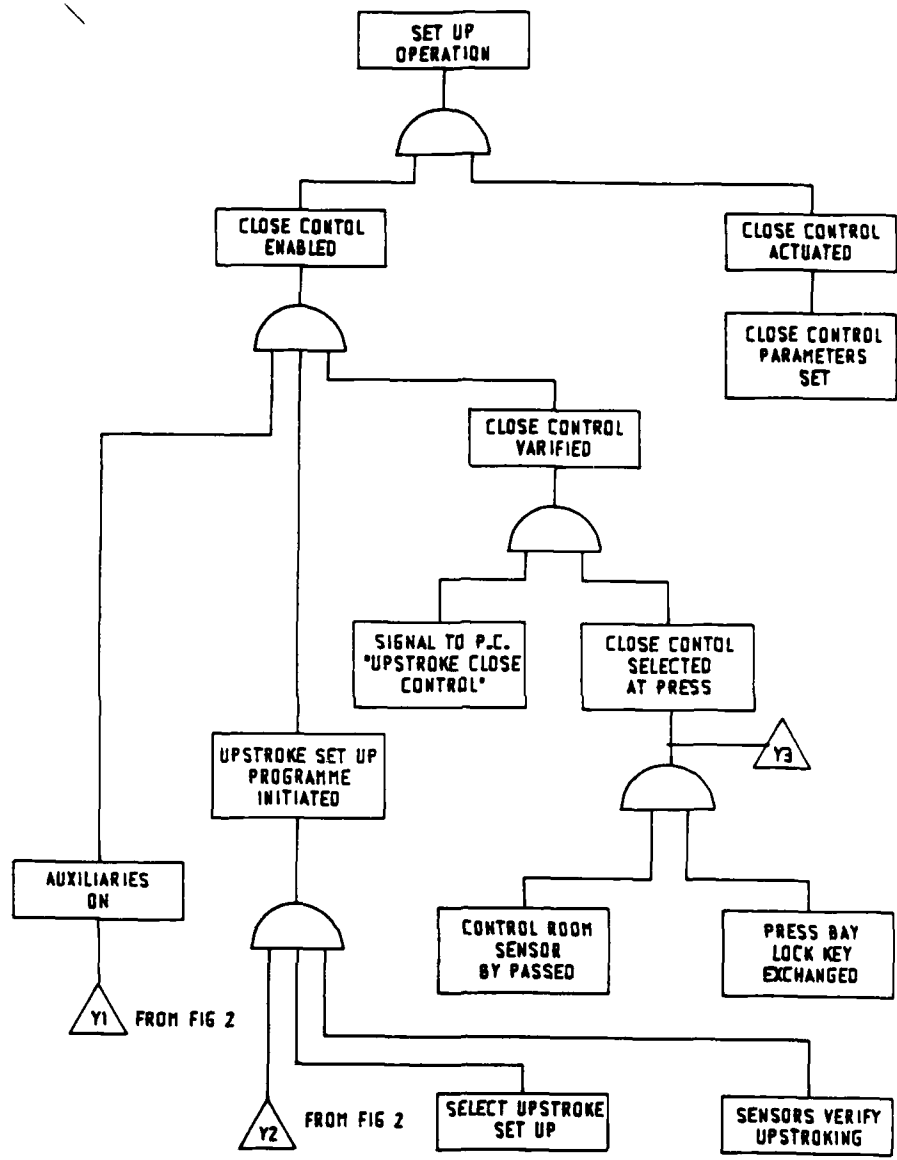

FIGURE 4 Safety Fault Tree for Upstroking Press. Set Up

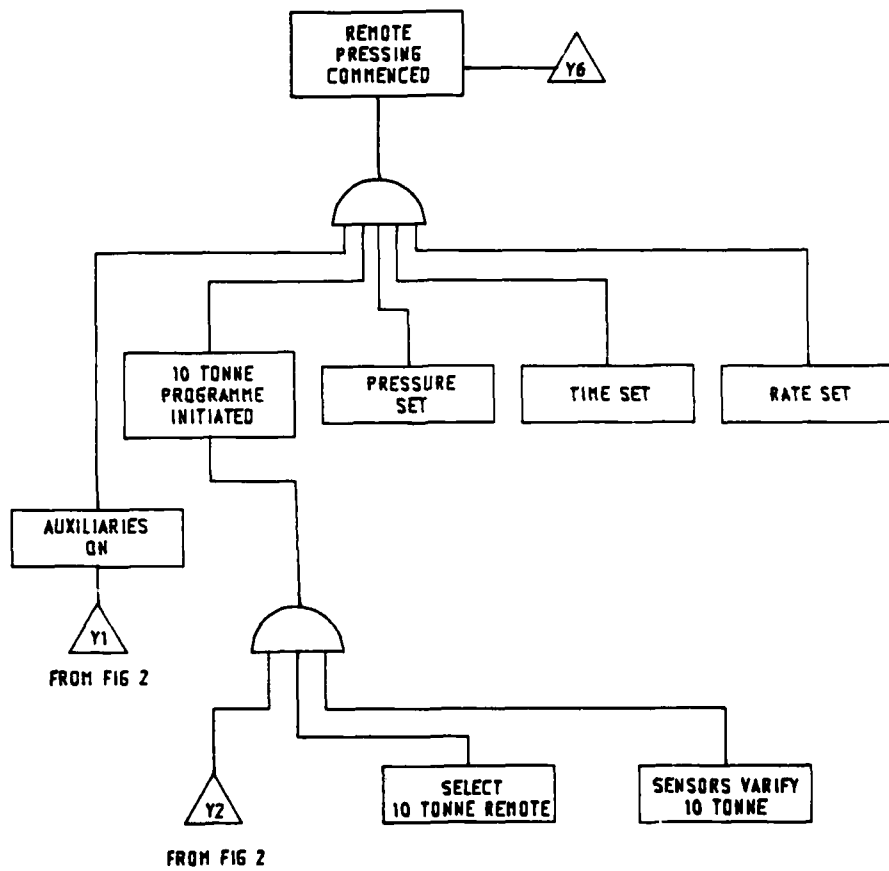

FIGURE 5 Safety Fault Tree for 10 Tonne Press. Remote

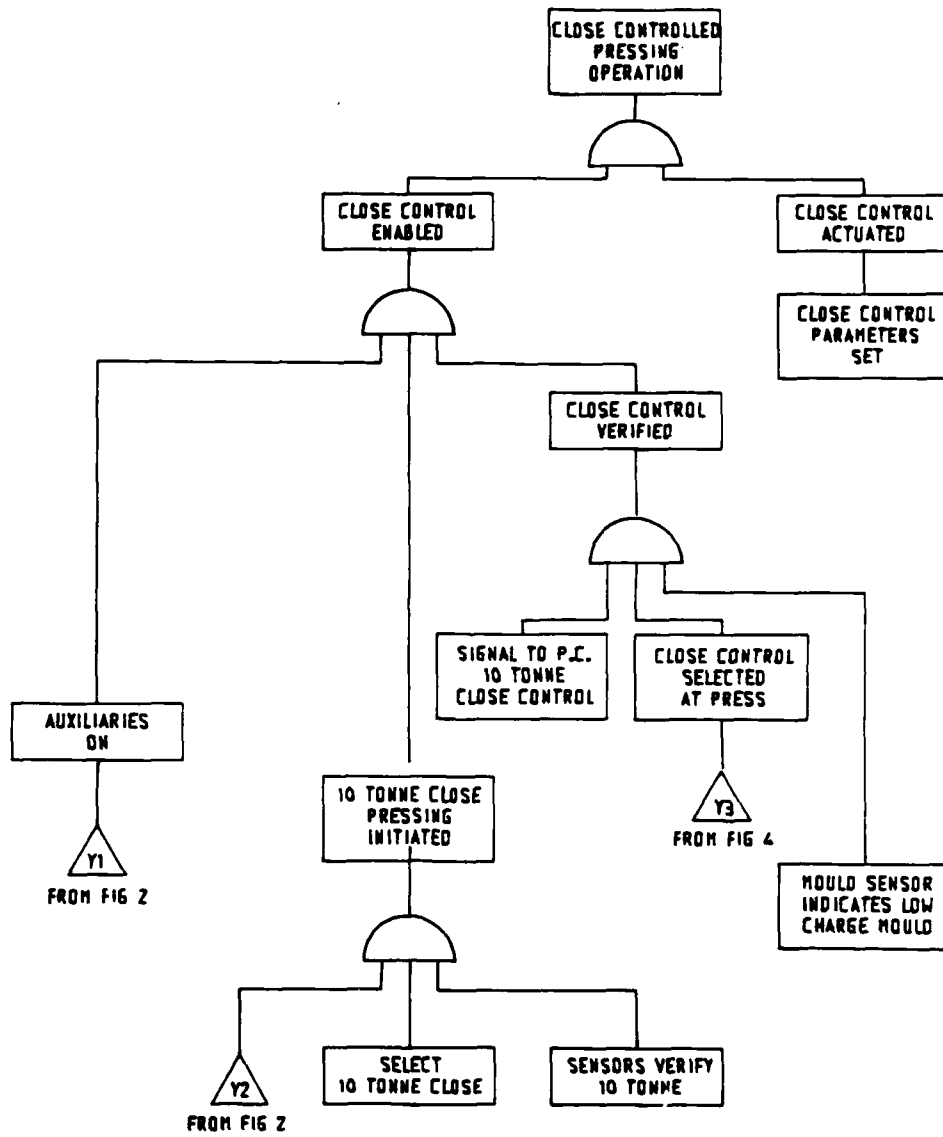

FIGURE 6 Safety Fault Tree 10 Tonne Press. Close

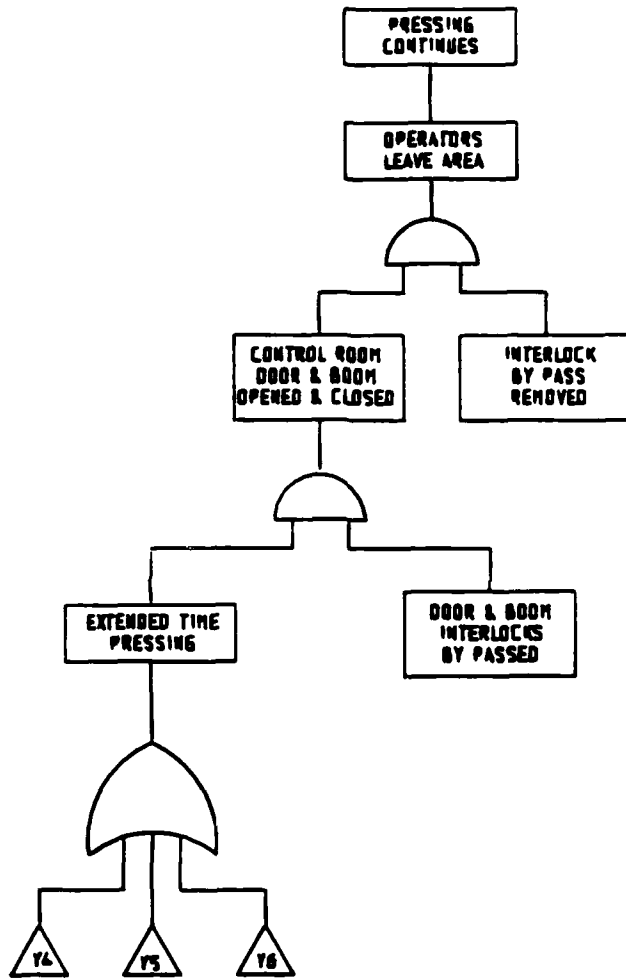

FIGURE 7 Safety Fault Tree for Leaving Facility During Remote Operation

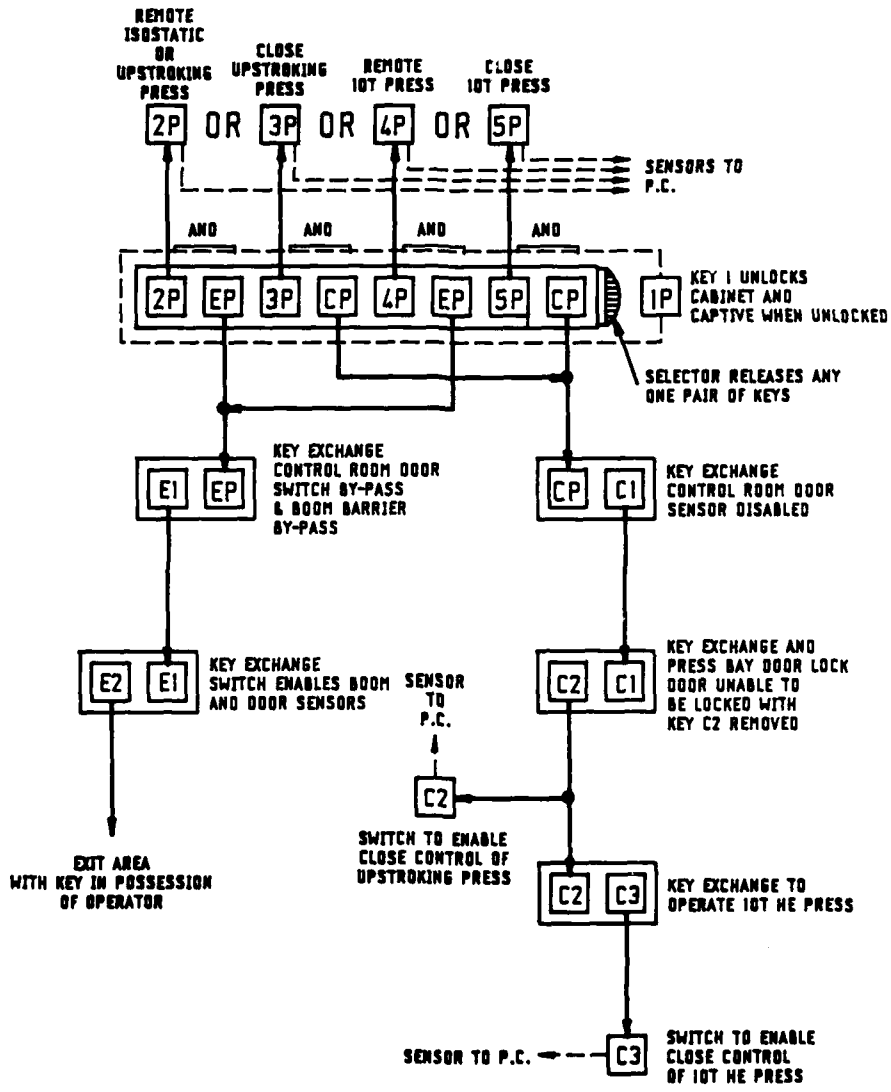

FIGURE 8 Mechanical Interlocks using Castell Locks

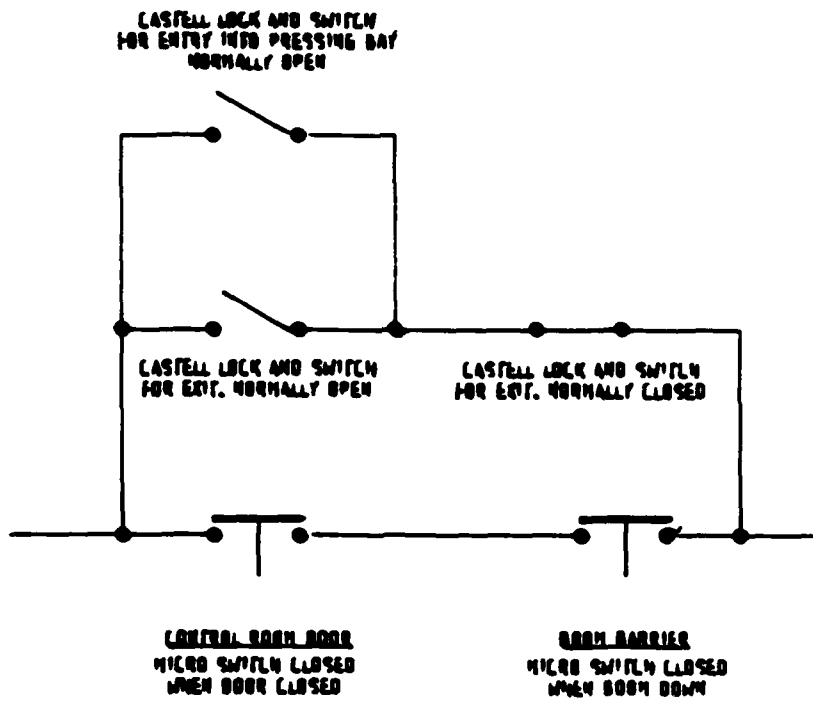

FIGURE 9 Electrical Schematic of Interlock System By-Pass

SECURITY CLASSIFICATION OF THIS PAGE

UNCLASSIFIED

DOCUMENT CONTROL DATA SHEET

REPORT NO.  
MRL-GD-0019

AR NO.  
AR-005-656

REPORT SECURITY CLASSIFICATION  
Unclassified

TITLE

Interlocking safety procedures for high explosive pressing  
facility at Materials Research Laboratory

AUTHOR(S)

M. Coxhead and  
R.C. Czigledy

CORPORATE AUTHOR

Materials Research Laboratory  
Defence Science & Technology Organisation  
PO Box 50  
Ascot Vale Victoria 3032

REPORT DATE  
September 1988

TASK NO.  
DST 99/023

SPONSOR  
DSTO

FILE NO.  
G6/4/8-3527

REFERENCES  
-

PAGES  
24

CLASSIFICATION/LIMITATION REVIEW DATE

CLASSIFICATION/RELEASE AUTHORITY  
Chief, Explosives Division MRL

SECONDARY DISTRIBUTION

Approved for Public Release

ANNOUNCEMENT

Announcement of this report is unlimited

KEYWORDS

Explosives pressing  
Safety

Control systems  
Presses

SUBJECT GROUPS 0079A

0094H

ABSTRACT

The Explosives Division Explosives Pressing Facility operates three presses requiring close or remote and extended period pressing modes. The safety interlock requirements for the facility are discussed and the means of providing them are described.

SECURITY CLASSIFICATION OF THIS PAGE

UNCLASSIFIED