

1000 001 0000

Naval Research Laboratory

Washington, DC 20375-5000



NRL Report 9182

AD-A205 458

**Phase Accuracy Experiments with a
Direct-Sampling Coherent Detector**

W. M. WATERS, G. J. LINDE AND B. R. JARRETT

*Search Radar Branch
Radar Division*

March 10, 1989

AS
DTIC
ELECTE
8 MAR 1989
S E D

Approved for public release; distribution unlimited.

89 3 08 050

REPORT DOCUMENTATION PAGE

Form Approved
OMB No 0704-0188

1a REPORT SECURITY CLASSIFICATION UNCLASSIFIED		1b RESTRICTIVE MARKINGS	
2a SECURITY CLASSIFICATION AUTHORITY		3 DISTRIBUTION/AVAILABILITY OF REPORT Approved for public release; distribution unlimited.	
2b DECLASSIFICATION/DOWNGRADING SCHEDULE			
4 PERFORMING ORGANIZATION REPORT NUMBER(S) NRL Report 9182		5 MONITORING ORGANIZATION REPORT NUMBER(S)	
6a NAME OF PERFORMING ORGANIZATION Naval Research Laboratory	6b OFFICE SYMBOL (if applicable) Code 5330.1W	7a NAME OF MONITORING ORGANIZATION	
6c ADDRESS (City, State, and ZIP Code) Washington, DC 20375-5000		7b ADDRESS (City, State, and ZIP Code)	
8a NAME OF FUNDING/SPONSORING ORGANIZATION Naval Air Development Center	8b OFFICE SYMBOL (if applicable) Code 40B	9 PROCUREMENT INSTRUMENT IDENTIFICATION NUMBER	
8c ADDRESS (City, State, and ZIP Code) Warminster, PA 18974-5000		10 SOURCE OF FUNDING NUMBERS	
		PROGRAM ELEMENT NO 62721N	PROJECT NO
		TASK NO XF21-232-100	WORK UNIT ACCESSION NO DN080-120
11 TITLE (Include Security Classification) Phase Accuracy Experiments with a Direct-Sampling Coherent Detector			
12 PERSONAL AUTHOR(S) Waters, W.M., Linde, G.J., and Jarrett, B.R.			
13a TYPE OF REPORT Final	13b TIME COVERED FROM _____ TO _____	14 DATE OF REPORT (Year, Month, Day) 1989 March 10	15 PAGE COUNT 14
16 SUPPLEMENTARY NOTATION			
17 COSATI CODES		18 SUBJECT TERMS (Continue on reverse if necessary and identify by block number)	
FIELD	GROUP	SUB-GROUP	
		Radar Direct sampling ;	
		Digital radar Phase measurement ;	
		Communications	
19 ABSTRACT (Continue on reverse if necessary and identify by block number)			
<p>The full potential of digital radar and communications signal processing may be realized only after errors in converting received signals to digital sample values are minimized. Coherent methods of analog-to-digital (A/D) conversion that preserve phase information fall into two classes—baseband and direct-sampling methods. As modern A/D converters have become faster, interest in direct-sampling approaches has grown; this report focuses on a direct-sampling digital coherent detector (DCD).</p> <p>The main advantage claimed for direct sampling over baseband detectors is improved phase accuracy. In the baseband case this is due to difficulties in matching separate <i>I</i> and <i>Q</i> channels. Data taken from the DCD demonstrate operation at carrier frequencies to 11.25 MHz with phase errors less than 0.8°. At frequencies less than 4 MHz, phase errors are less than 0.3°; this corresponds to time-measurement accuracy better than 230 picoseconds (ps). A brief review of the rules of direct sampling precedes descriptions of the approach, hardware implementation, instrumentation, test results, and conclusions.</p>			
20 DISTRIBUTION/AVAILABILITY OF ABSTRACT <input checked="" type="checkbox"/> UNCLASSIFIED/UNLIMITED <input type="checkbox"/> SAME AS RPT <input type="checkbox"/> DTIC USERS		21 ABSTRACT SECURITY CLASSIFICATION UNCLASSIFIED	
22a NAME OF RESPONSIBLE INDIVIDUAL William M. Waters		22b TELEPHONE (Include Area Code) (202) 767-2178	22c OFFICE SYMBOL Code 5330.1W

CONTENTS

INTRODUCTION	1
SAMPLING FUNDAMENTALS	1
DIGITAL COHERENT DETECTOR (DCD) DESIGN	2
HARDWARE DESIGN AND FABRICATION	4
INSTRUMENTATION	5
RESULTS	7
SUMMARY AND CONCLUSIONS	9
ACKNOWLEDGMENTS	10
REFERENCES	10

Accession For	
NTIS GRA&I	<input checked="" type="checkbox"/>
DTIC TAB	<input type="checkbox"/>
Unannounced	<input type="checkbox"/>
Justification	
By _____	
Distribution/	
Availability Codes	
Dist	Avail and/or Special
A-1	

PHASE ACCURACY EXPERIMENTS WITH A DIRECT-SAMPLING COHERENT DETECTOR

INTRODUCTION

The coherent conversion of radar and communications signals into digital form may be accomplished by frequency translating the signal to in-phase and quadrature (I and Q) baseband channels, each containing an analog-to-digital (A/D) converter, or by sampling and digitizing the signal directly in the radio frequency (RF) or intermediate frequency (IF) sections of the receiver. Considerable interest in the latter approach has developed in recent years [1-5] since A/D converters have become faster and less hardware is needed; direct-sampling methods have been shown to be more accurate, especially if signals vary over a wide dynamic range.

This report describes a direct-sampling coherent detector model. The model is capable of converting samples of radar or communications signals having intermediate carrier frequencies up to 30 MHz [1] and bandwidths up to 5 MHz to corresponding digitized samples of I and Q . Tests described here demonstrate phase accuracies better than 0.3° at IF frequencies below 4 MHz.

The report briefly reviews the rules of direct sampling to clarify the method used to derive I and Q values from these samples. Special attention is devoted to the general problem of measuring phase accuracy since the estimated accuracy of the device under test exceeds that of readily available phase standards. Test instrumentation and results are presented, followed by a discussion of the effect of phase noise and A/D converter aperture uncertainty on the experimental data.

SAMPLING: FUNDAMENTALS

If the spectrum $R(f)$ of a signal $r(t)$ contains no energy outside a band from $-W$ to $+W$, $r(t)$ may be represented without loss of information by samples $r(t_n)$, taken at points t_n , spaced by no more than $1/2 W$. That is, $r(t)$ may be exactly reconstructed from these equally spaced sampled values, $r_n = r(t_n)$. The above two sentences state, in terms appropriate for this report, the sampling theorem given by Shannon in 1949 [6].

A similar theorem may be stated for bandpass signals. If the spectrum $R(f)$ of a signal $r(t)$ contains no energy outside the bands specified by the inequality $(M - 1)W \leq |f| \leq MW$ (M is any positive integer), then $r(t)$ may be exactly reconstructed from sampled values r_n taken at points spaced by $t_n - t_{n-1} = 1/2 W$. Note that the sampling rate in this bandpass case must equal $2W$; in the lowpass case, $2W$ is simply a lower bound on sampling rate.

It is worth mentioning in passing that this restriction may be avoided if second-order sampling* is performed. However, this involves unequal sample spacing, and we therefore confine our attention to the case where energy is confined to the bands defined by $(M - 1)W \leq |f| \leq MW$.

Manuscript approved October 28, 1988.

*Linden's paper [7] provides a lucid review of sampling theorems. Although minimum sampling speed is often called the Nyquist rate, Shannon [6] is usually credited with proving that a band limited signal may be exactly reconstructed from samples.

This restriction on the frequency band imposes a corresponding, but not damaging, restriction on center frequency, $f_0 = (2M - 1)W/2$. Since M is a positive integer, the allowed values of f_0 may be written $W/2, 3W/2, 5W/2, \dots$. Hence, the system designer may select an IF that is high enough to avoid filtering problems but low enough to avoid problems with A/D converter aperture uncertainty. Comments on this trade-off are included in the final section of the report.

DIGITAL COHERENT DETECTOR (DCD) DESIGN

Figure 1 plots a segment of a Gaussian pulse-modulated sine wave to illustrate the locations of direct-sample points when $M = 3$. The pulse is time-shifted arbitrarily so that it peaks at $t = 3$; its carrier frequency is 2.5 with $\pi/4$ phase shift, and the Nyquist bandwidth is $W = 1$.

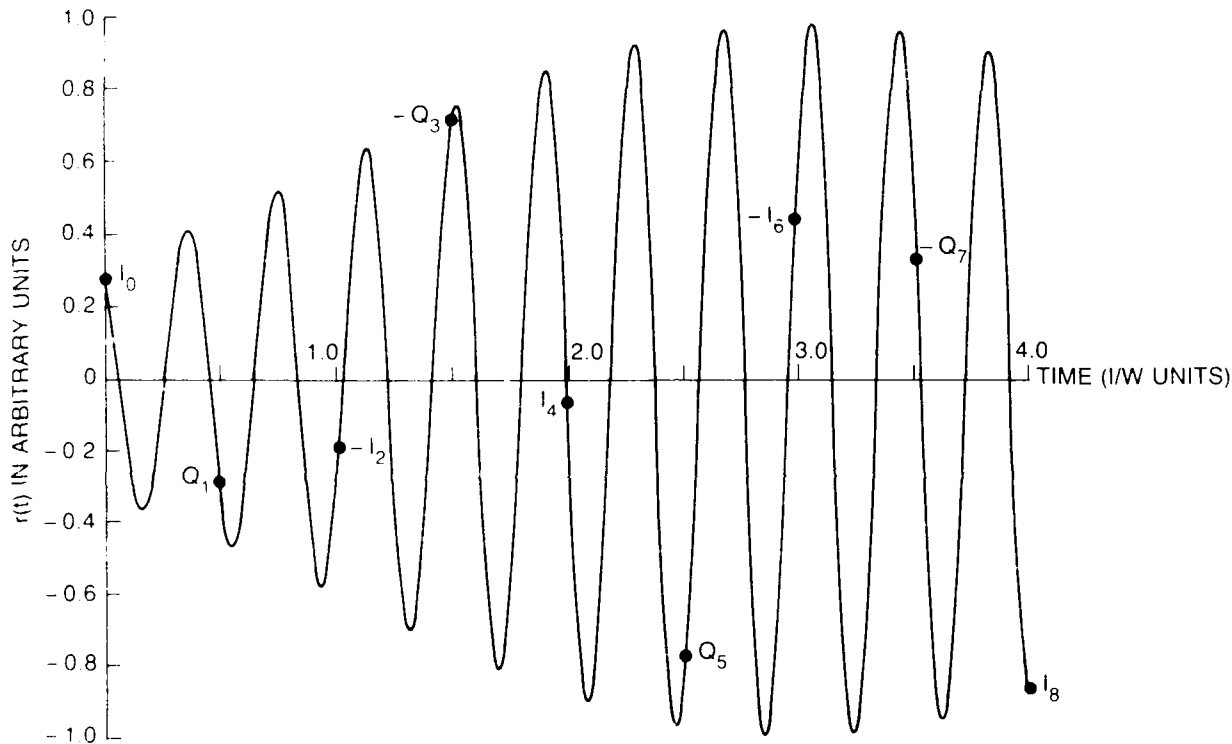

Fig. 1 - Sine wave modulated by Gaussian pulse. Sample points are labeled with corresponding I_n , Q_n values.

Figure 2 is a simplified block diagram of the DCD. The actual bandwidth B of the signal-plus-noise is determined by the receiving filter and must be less than W . Digitized sampled values (r_n) are processed as follows to provide corresponding I_n and Q_n values.

A sample point is selected to correspond to $t = 0$. Since the $I_n = (-1)^{n/2}r_n$ for even n under these assumptions [1,2], $I_0 = r_0$, $I_2 = -r_2, \dots$, as shown in Fig. 1. When n is odd, $Q_n = (-1)^{(n-1)/2}r_n$. This leads to the Q_n values noted in Fig. 1. Hence, for these I_n and Q_n values ($I_0, Q_1, I_2, Q_3, \dots$), the only computing necessary consists of switching the sampled value to the correct output port.

DCD applications often demand accurate phase where the values $Q_0, I_1, Q_2, I_3, \dots$ must be computed. This computation requires a digital filtering operation. Another investigator [2] has developed a solution to this problem based on the Hilbert transform. The method described here and in Refs. 1, 4, and 5 uses a modification of the sampling theory interpolation function, sometimes

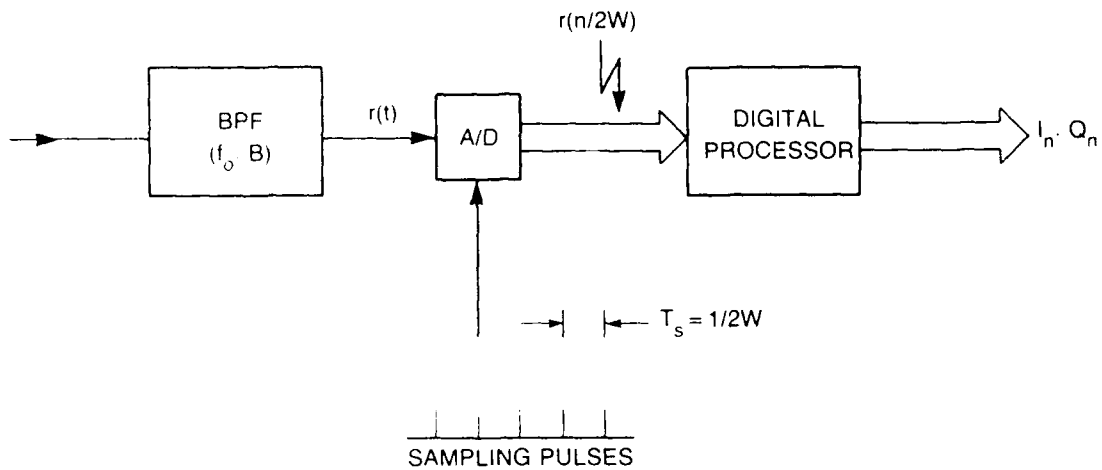

Fig. 2 — Basic coherent detector approach

called a frequency-window function. Both methods provide exact values if the interpolation is based on arbitrarily long data sequences. However, practical interpolation must be computed on a finite block of sample data. Thus we used work by Helms and Thomas [8] based on what they term "self-truncating" modifications of the conventional sampling function (a cardinal function in the low-pass case). The thrusts of their work were the improvement of interpolation accuracy and the reduction of truncation length, hence the length of the interpolation filter impulse response.

Figure 3 shows the means used to compute values of Q_n for even n and I_n for odd n . We continue to deal with the example of Fig. 1 ($M = 3$). By using finite impulse response (FIR) filter weights (determined by the above-mentioned interpolation function) we estimate a value of $r(t_n + 1/4 f_0')$. If $f_0' \gg W$, this time shift of $1/4 f_0'$ is equivalent to a 90° phase shift; hence, $r(0 + 1/4 f_0') = Q_0$. Since f_0' is a fictitious carrier frequency, it can be made arbitrarily large; this makes $(-1)^{n/2} r(t_n + 1/4 f_0')$ arbitrarily close to Q_n for even n . Similarly, $(-1)^{(n-1)/2} r(t_n + 1/4 f_0')$ approaches I_n for odd n [1,4].

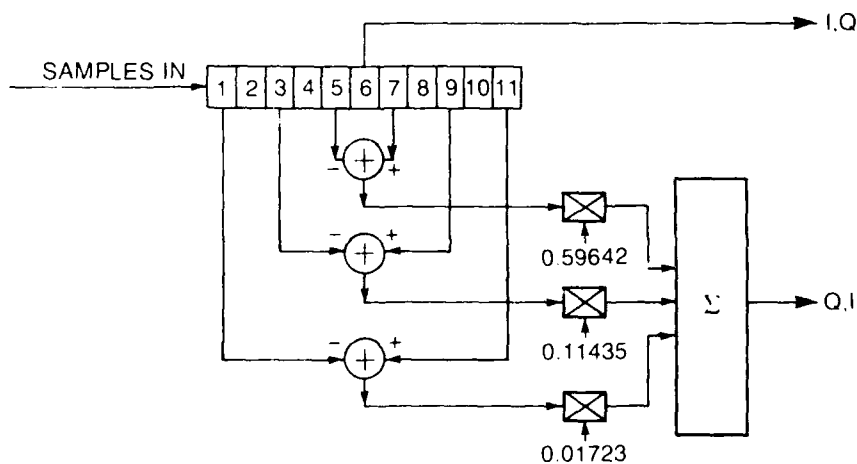

Fig. 3 -- FIR filter for I, Q interpolation

The FIR filter shown in Fig. 3 computes an estimate of $r(t_m + 1/4 f_0')$ based on samples of $r(t)$. It happens that the interpolation function is odd symmetric, with zeros at even-valued displacements from its center (stages 2, 4, 6, 8, and 10 in Fig. 3). Hence, only three multiplies are needed in an 11-sample truncation. A brief study of the effect of truncation length was conducted prior to designing the hardware described in the next section of this report.

In principle, only the filter shown in Fig. 3 is needed. A form of the Nyquist theorem states that complex samples taken at a rate W is sufficient; hence we need only values of I and Q for even values of n , with the value at stage six being $\pm I$ and the output value of the FIR filter being $\pm Q$.

In Fig. 4, which represents the hardware actually used, switching provides a pair of I and Q values for each sample. This oversampling of I and Q economically provides additional redundancy for greater phase accuracy.

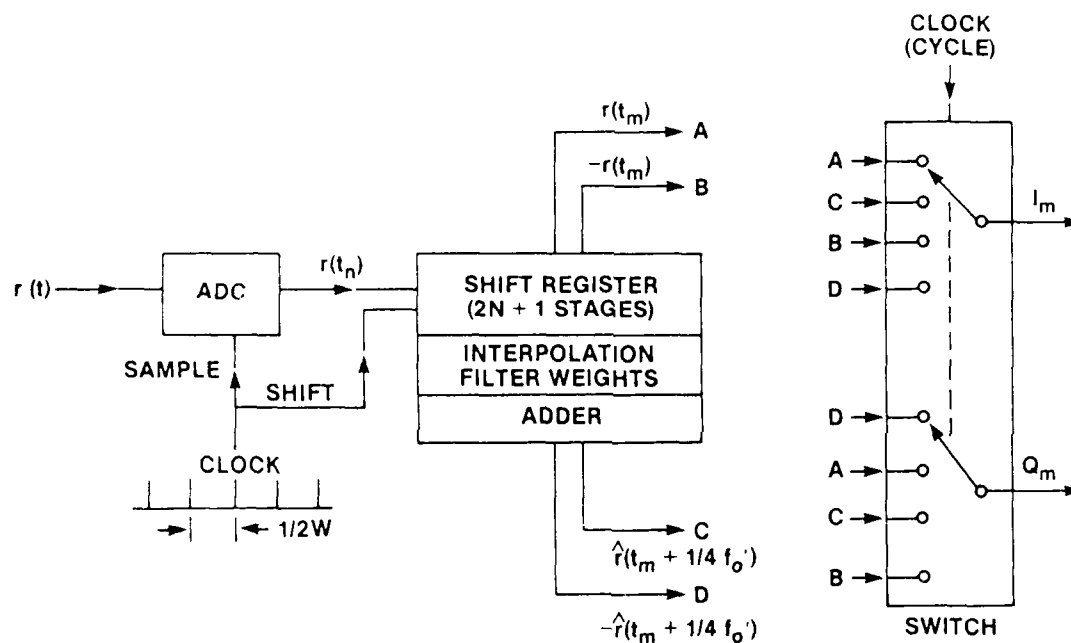

Fig. 4 --- DCD hardware diagram

HARDWARE DESIGN AND FABRICATION

The FIR filter shown in Fig. 3 was fabricated in a compact form. Earlier work [1,4] dealt with as many as 21 filter stages. However, in the model described here, only 11 stages were actually implemented. This was because the outer weights were so small that their effect on accuracy could be ignored. Choice of a 12-bit A/D posed the question whether to use 12-bit or 16-bit multipliers. The 12-bit selection created a need to contract (divide by two) before the multipliers and expand (multiply by two) after the multipliers because of the summation operation preceding them.

Figure 5 shows the hardware implementation of the switch in Fig. 4. Signs for the multiplexed I, Q data were obtained from the formulas given in the previous section.

Two identical detectors were fabricated to provide two channels of I and Q data for the SEN-RAD radar located at NRL's Chesapeake Bay Detachment (CBD). The detectors were constructed of approximately 80 74LS-series transistor-transistor logic (TTL) devices and 3 complementary metal oxide semiconductor (CMOS) (Analog Devices 1012) multipliers with TTL I/O compatibility. Each was fabricated on one universal-type wire wrap board (Mupac 202).

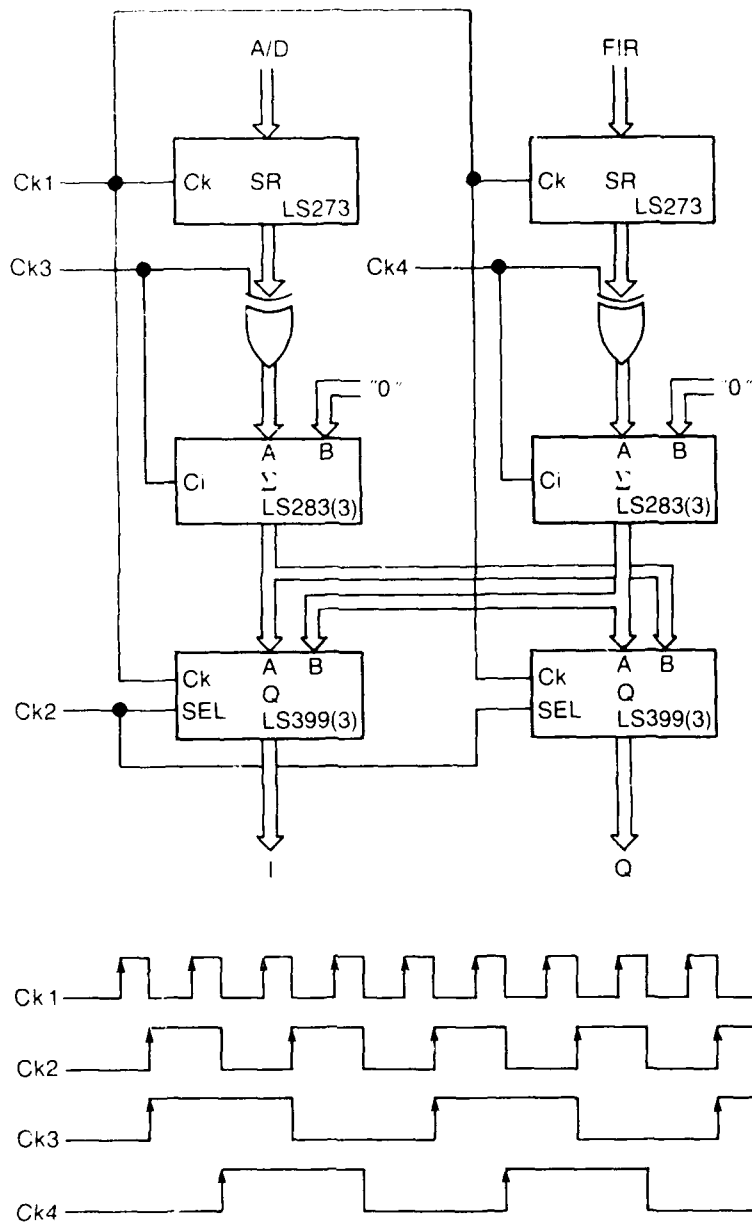

Fig. 5 -- Inversion and multiplexing circuit

INSTRUMENTATION

To test a phase detector such as the DCD, a precise phase shifter is desired that can vary the input phase while the output values are being read. In practice such phase shifters, which are needed to measure the predicted 0.05° error of the DCD, are not readily available. We decided to use a low-noise signal source with the capability of exact frequency settings relative to the sampling frequency. This source provided a signal where the phase change from one sample to any other sample was precisely known. Phase noise of the signal source will corrupt the predicted values; since only the relative phase needs to be accurate and the time between samples is short, the phase error caused by the source was very small.

Figure 6 is a diagram of the test instrumentation. An HP3335A synthesizer is locked to a low-noise, external 10 MHz reference oscillator; this reference oscillator also is used to generate the 5

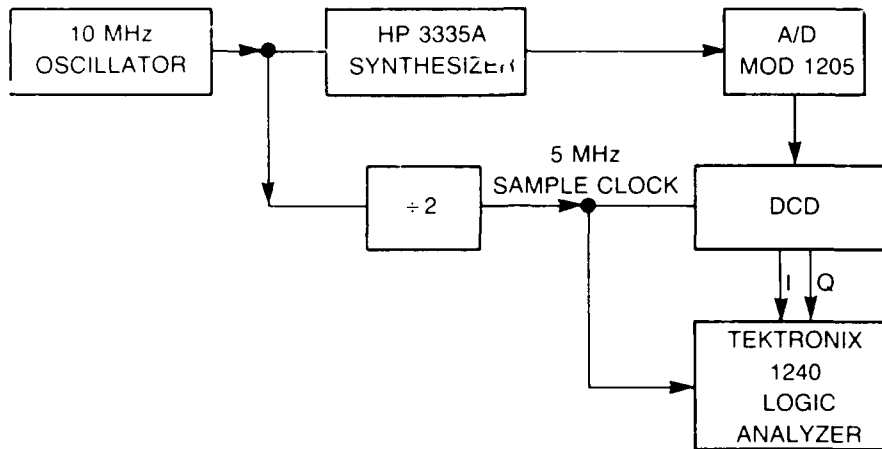

Fig. 6 — Test instrumentation

Table 1 — Measured *I* and *Q* Data ($X = Q, Y = I$)
(Signal level, 0.28 V rms)*

Sample	<i>X</i>	<i>Y</i>	Deg. Calc.	Deg. Measure	Error
-125	13	-354	180.00	177.90	-2.10
-120	-24	-346	-172.80	-176.03	-3.23
-110	-123	-329	-158.40	-159.50	-1.10
-100	-191	-290	-144.00	-146.63	-2.63
-90	-267	-229	-129.60	-130.62	-1.02
-80	-305	-160	-115.20	-117.68	-2.48
-70	-345	-77	-100.80	-102.58	-1.78
-60	-344	7	-86.40	-88.83	-2.43
-50	-339	94	-72.00	-74.50	-2.50
-40	-298	173	-57.60	-59.86	-2.26
-30	-249	246	-43.20	-45.35	-2.15
-20	-181	299	-28.80	-31.19	-2.39
-10	-96	334	-14.40	-16.04	-1.64
0	0	347	0.00	0.00	0.00
10	64	340	14.40	10.66	-3.74
20	170	309	28.80	28.82	.02
30	220	260	43.20	40.24	-2.96
40	295	193	57.60	56.81	-.79
50	321	118	72.00	69.82	-2.18
60	351	31	86.40	84.95	-1.45
70	341	-51	100.80	98.51	-2.29
80	322	-134	115.20	112.59	-2.61
90	277	-215	129.60	127.82	-1.78
100	212	-278	144.00	142.67	-1.33
110	141	-319	158.40	156.15	-2.25
120	53	-342	172.80	171.19	-1.61
125	14	-344	180.00	177.67	-2.33

*Frequency difference from 6.25 MHz is 20,000 Hz

5 MHz sampling frequency of the DCD. The HP3335A can be set to any frequency in the processing range of the DCD, within 0.001 Hz. The signal is digitized by a 12 bit Analog Devices MOD-1205 A/D converter, and the digitized values are the inputs of the DCD. I and Q outputs of the DCD were measured by a Tektronix 1240 logic analyzer.

The logic analyzer was set to trigger when the Q value was zero; then selected samples on both sides of the trigger point were read out. Table 1 is an example of the data. The sample numbers are in units of the 5 MHz sampling frequency. X and Y are the Q and I outputs respectively of the DCD. The Deg. Calc. column contains phase values based on the offset frequency and assuming zero at the trigger sample. The Deg. Measure column lists angles calculated from DCD outputs. Note that by definition, the error is always zero at the trigger sample; however the actual phase of the signal will not be exactly zero because of A/D converter quantization and aperture uncertainty. So the measured data will have small bias errors that are not due to the DCD and thus are not considered in the evaluation of DCD performance in the following sections.

RESULTS

Table 2 contains DCD data taken by using two different A/D converters. Since A/D 51 yielded better results, it was used throughout subsequent tests.

Table 2 — A/D Converter Comparison
(Signal power = 12 dBm)

Data Set*	N	Δt	σ_1	σ_2	σ_3	Comment
15-6-02-0	25	10	.528	.525	.507	A/D 50/Red
15-6-02-1	39	5	.398	.398	.476	A/D 51/Blue
15-6-02-1	50	5	.585	.585	.557	A/D 51/Blue

*Data set information signifies date-band center-signal offset/A/D converter; Δt is the number of samples between stored values.

Figure 7 shows the effect of center frequency on phase accuracy. Note that two phase accuracy measures are plotted against center frequency $f_0 = (2M - 1)f_c/4$, where M is an integer and $f_c = 2W = 5$ MHz. In Fig. 7, 1.25, 3.75, 6.25, 8.75, and 11.25 MHz correspond to values of M from 1 to 5, respectively.

RMS phase errors σ_1 , σ_2 , and σ_3 are calculated as follows. If ϕ_i is the i th phase measurement ($\phi_i = \tan^{-1}(Q_i/I_i)$), it can be shown [4] that the variance of ϕ_i (sine wave separated in frequency from f_0 by Δf) may be expressed by

$$\sigma_1^2 = (\Delta\phi_i - 2\pi\Delta f\Delta t)^2/2,$$

where

$$\Delta\phi_i = \phi_{i+1} - \phi_i,$$

Δt is the interval between samples, and

the bar indicates averaging over the range of i .

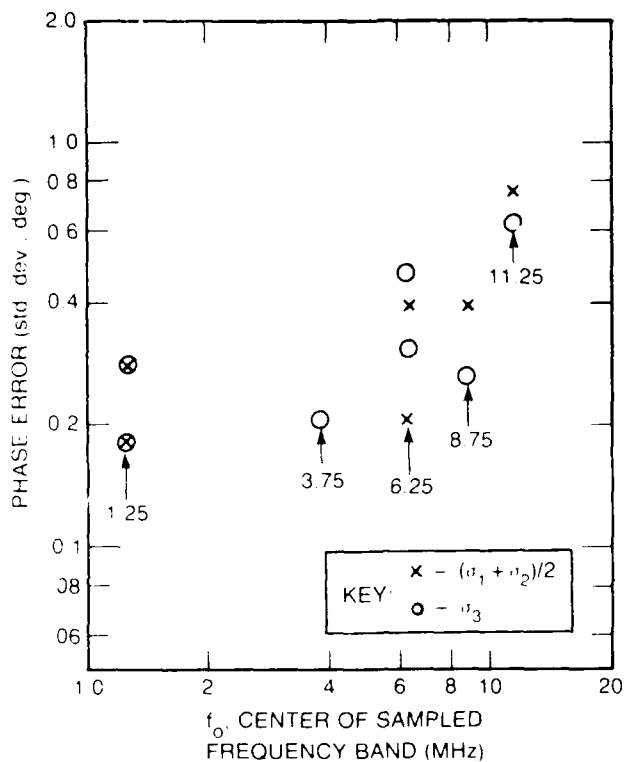

Fig. 7 - DCD phase error vs frequency

If signal frequency is constant but unknown, we may compute $\sigma_2^2 = \overline{(\Delta\phi_i - \Delta\phi_1)^2}/2$. As the data in Table 2 show, very little difference existed between σ_1 and σ_2 because our knowledge of Δf was precise; thus $(\sigma_1 + \sigma_2)/2$ was plotted along with σ_3 in Fig. 7.

Calculation of σ_3 implies even more precise knowledge of signal frequency. Assuming $\phi_1 = \phi'_1$, we again assume frequency is constant so that the actual phase of the signal is $\phi'_i = \phi_1 + 2\pi(i-1)\Delta f\Delta f$. In this case, $\sigma_3 = \overline{(\phi_i - \phi'_i)^2}$. Clearly, if Δf is not accurately known, ϕ'_i will be in error for large i . Note that some difference exists between values of $(\sigma_1 + \sigma_2)/2$ and σ_3 for the higher frequencies.

All of the points plotted in Fig. 7 were plotted with $\Delta f = 20$ kHz. Table 3 lists data sets intended to demonstrate the effect of greater separation of signal frequency from band center. Since sampling rate $f_s = 5$ MHz, the Nyquist band $W = 2.5$ MHz, so the maximum value $\Delta f = 1.25$ MHz. Note that the largest value of Δf in Table 3 is 0.539 MHz corresponding to one edge of a centered signal band of width $B = 1.078$ MHz. Hence, this signal is oversampled by $\sim 16\%$.

Calculations were done to predict errors that an ideal DCD would produce as a function of input frequency. The input signal was sampled, and the samples were truncated to 12-bit values. Integer arithmetic was used to simulate the calculations performed by the DCD. Figure 8 shows the rms error as a function of the input frequency; each point is calculated from 150 consecutive outputs of the DCD. The center frequency is 6.25 MHz, and the sampling rate is 5.0 MHz. Near center frequency, the predicted errors are $\sim 0.05^\circ$, errors remain below 0.1° for an input frequency within 0.54 MHz of the center, then increase rapidly for frequency offsets that are greater.

A new algorithm is being defined by another investigator [10] that is expected to further reduce digital coherent detector phase errors. At the expense of another FIR filter, errors are expected to be reduced by at least an order of magnitude below those plotted in Fig. 8.

Table 3 — Accuracy vs Frequency Offset (Δf)
 (Signal power = 12 dBm, $\Delta t = 5$, A/D 51 Blue)

Data Set*	N	Δf (MHz)	σ_1	σ_2	σ_3
23/6/02/1	12	.02	.209	.209	.310
23/6/15/1	32	.150	.353	.353	.308
23/6/53/1	12	.539	.310	.309	.286

*Data set information signifies date/band center/signal offset/A/D converter; Δt is the number of samples between stored values.

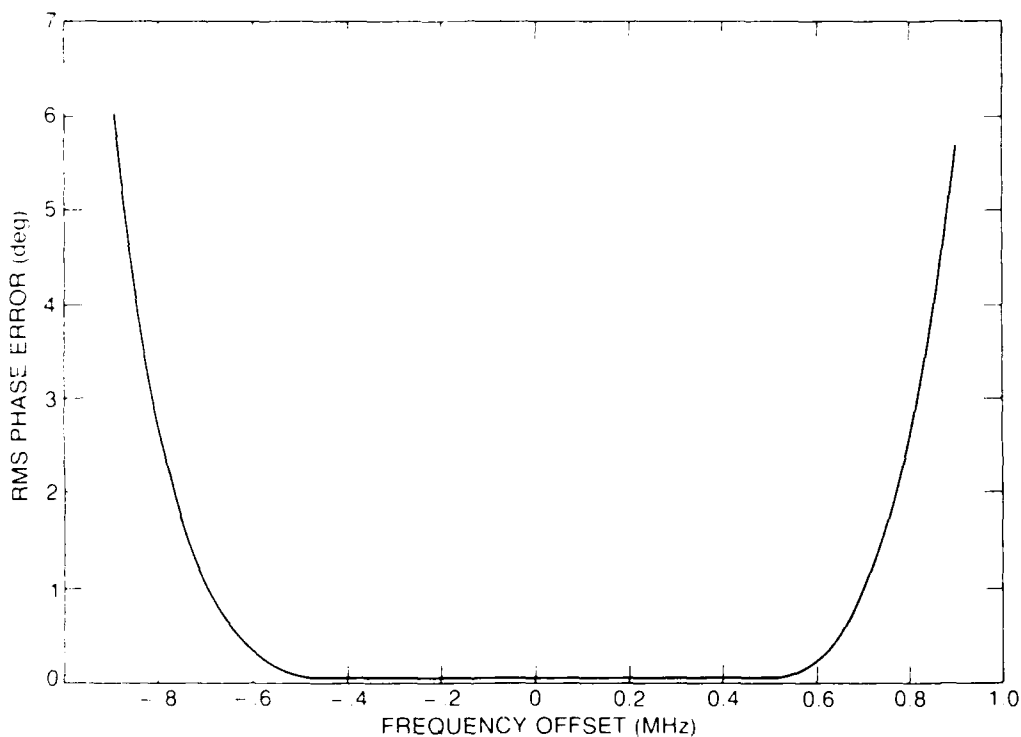

Fig. 8 — Calculated phase error vs input frequency for 12-bit inputs
 (center frequency, 6.25 MHz; sampling rate, 5.0 MHz)

SUMMARY AND CONCLUSIONS

We have described hardware capable of converting radar and communications signals sampled directly from RF or IF portions of a receiver. By sampling bandpass signals directly, the need for dividing signals into parallel channels and converting to baseband is avoided. As a consequence, errors caused by mismatch between baseband channels are avoided, particularly when large received power variations, typical of radar signals, are involved. Measurements of phase provided by this hardware demonstrate its intrinsic accuracy.

Phase is basically a measure of time of arrival of the sine wave signal, relative to the sampling pulse train (strobe). If band center is 10 MHz, $\sigma = 1^\circ$ corresponds to measuring time to an accuracy better than 1/3 ns. Note that measured $\sigma < 0.3^\circ$ at $f_0 = 3.75$ MHz, which corresponds to time accuracy better than 230 ps.

Time measurement accuracies that significantly exceed the reciprocal of the signal bandwidth imply good signal-to-noise ratio (SNR). Swerling's estimate ([9], pp. 4-7, Eq. (33)) $1/(\sqrt{2} \cdot W \cdot \text{SNR})$ is the expected rms time measurement error, and W is the bandwidth. The measured value of $\sigma_T = 100$ ps implies that $\text{SNR} > 34$ dB ($W = 2.5$ MHz). This is well within the SNR implied by +12 dBm signal level and a 1 mV least-significant bit (59 dB).

There may be an error minimum at 3.75 MHz (Fig. 7). Phase noise spectra of most sine wave sources diminish as frequency increases. However, the error caused by the A/D converter increases with increased frequency as the signal period approaches aperture uncertainty time. The tentative conclusion is that below 3.75 MHz errors are due mostly to phase noise, with A/D aperture uncertainty causing errors at the higher frequencies.

In conclusion, we believe that even better performance may be expected as better direct-sampling A/D converters become available. Note that calculated errors assuming an ideal 12-bit A/D converter (Fig. 8) are $\sim 0.05^\circ$, compared with values shown in Fig. 7. Further research toward better direct-sampling A/D converters is recommended.

ACKNOWLEDGMENTS

The authors acknowledge the technical contributions of E. Piernik, L. Gott, and M. Crisman. The work was sponsored by the Office of Naval Technology under the Surveillance and Command and Control program elements.

REFERENCES

1. W.M. Waters and B.R. Jarrett, "Bandpass Signal Sampling and Coherent Detection," *IEEE Trans. Aerospace Electron. Syst.* **AES-18**(4), 731-736 (1982).
2. D.W. Rice and K.H. Wu, "Quadrature Sampling with High Dynamic Range," *IEEE Trans. Aerospace Electron. Syst.* **AES-18**(4), 736-739 (1982).
3. C.M. Rader, "A Simple Method for Sampling In-phase and Quadrature Components," *IEEE Trans. Aerospace Electron. Syst.* **AES-20**(6) (1984).
4. W.M. Waters and B.R. Jarrett, "Test of Direct-Sampling Coherent Detection with a Laboratory Analog-to-Digital Converter," *IEEE Trans. Aerospace Electron. Syst.* **AES-21**(3), 430-432 (1985).
5. W.M. Waters, G.J. Linde, B.R. Jarrett, and C.T. Lin, "Processing Directly Sampled Radar Data," *IEEE 1985 International Radar Conf. Proc.*, pp. 397-402.
6. C.E. Shannon, "Communication in the Presence of Noise," *Proc. IRE*, Jan. 1949, pp. 10-21.
7. D.A. Limb, "A Discussion of Sampling Theorems," *Proc. IRE*, July 1959, pp. 1219-1226.
8. H.D. Helms and J.B. Thomas, "Truncation Error Sampling Theorem Expansions," *Proc. IRE*, Feb. 1962, pp. 179-184.
9. M.I. Skolnik, ed., *Radar Handbook* (McGraw-Hill, New York, 1970).
10. J.P. Hansen, Naval Research Laboratory, private communication.