

DTIC FILE COPY

4

AD

AD-E401 904

AD-A205 964

Contractor Report ARAED-CR-89003

**SOFT IGNITION SYSTEM FOR SELF-CONTAINED MUNITIONS**

Michael Liva  
Matthew Webb  
GEO-CENTERS, Inc.  
7 Wells Avenue  
Newton Centre, MA 02159

**DTIC**  
**SELECTED**  
MAR 27 1989  
**S D**  
D<sup>CS</sup>

Richard Field  
Project Engineer  
ARDEC

March 1989



US ARMY  
ARMAMENT MUNITIONS  
& CHEMICAL COMMAND  
ARMAMENT RDE CENTER

**U.S. ARMY ARMAMENT RESEARCH, DEVELOPMENT AND  
ENGINEERING CENTER**

**Armament Engineering Director**

**Picatinny Arsenal, New Jersey**

Approved for public release; distribution unlimited.

0 0 0 0 0 0 0

The views, opinions, and/or findings contained in this report are those of the author(s) and should not be construed as an official Department of the Army position, policy, or decision, unless so designated by other documentation.

The citation in this report of the names of commercial firms or commercially available products or services does not constitute official endorsement by or approval of the U.S. Government.

Destroy this report when no longer needed by any method that will prevent disclosure of contents or reconstruction of the document. Do not return to the originator.

REPORT DOCUMENTATION PAGE

1a. REPORT SECURITY CLASSIFICATION UNCLASSIFIED			1b. RESTRICTIVE MARKINGS			
2a. SECURITY CLASSIFICATION AUTHORITY			3. DISTRIBUTION/AVAILABILITY OF REPORT  Approved for public release; distribution unlimited.			
2b. DECLASSIFICATION/DOWNGRADING SCHEDULE						
4. PERFORMING ORGANIZATION REPORT NUMBER GC-TR-88-1545			5. MONITORING ORGANIZATION REPORT NUMBER Contractor Report ARAED-CR-89003			
6a. NAME OF PERFORMING ORGANIZATION GEO-CENTERS, INC.		6b. OFFICE SYMBOL		7a. NAME OF MONITORING ORGANIZATION ARDEC, AED		
6c. ADDRESS (CITY, STATE, AND ZIP CODE) 7 Wells Avenue Newton Centre, MA 02159			7b. ADDRESS (CITY, STATE, AND ZIP CODE) Energetics and Warheads Div (SMCAR-AEE-B) Picatinny Arsenal, NJ 07806-5000			
8a. NAME OF FUNDING/SPONSORING ORGANIZATION ARDEC, IMD STINFO Br		8b. OFFICE SYMBOL SMCAR-IMI-I		9. PROCUREMENT INSTRUMENT IDENTIFICATION NUMBER DAAK10-85-C-0116		
8c. ADDRESS (CITY, STATE, AND ZIP CODE) Picatinny Arsenal, NJ 07806-5000			10. SOURCE OF FUNDING NUMBERS			
			PROGRAM ELEMENT NO.	PROJECT NO.	TASK NO.	WORK UNIT ACCESSION NO.
11. TITLE (INCLUDE SECURITY CLASSIFICATION)  SOFT IGNITION SYSTEM FOR SELF-CONTAINED MUNITIONS						
12. PERSONAL AUTHOR(S) Michael Liva and Matthew Webb, GEO-CENTERS, Inc. and Richard Field, ARDEC Project Engineer						
13a. TYPE OF REPORT Final		13b. TIME COVERED FROM Jan 85 TO Aug 87		14. DATE OF REPORT (YEAR, MONTH, DAY) March 1989		15. PAGE COUNT 92
16. SUPPLEMENTARY NOTATION						
17. COSATI CODES			18. SUBJECT TERMS (CONTINUE ON REVERSE IF NECESSARY AND IDENTIFY BY BLOCK NUMBER) Laser ignition; Multiple-point ignition; Ignitors; Soft ignition systems Lova propellants; <i>(S)</i>			
FIELD	GROUP	SUB-GROUP				
19. ABSTRACT (CONTINUE ON REVERSE IF NECESSARY AND IDENTIFY BY BLOCK NUMBER)  A laser ignited multiple-point ignition system was designed, fabricated, and tested in a gun simulator using live propellant. Details of the fiber optic coupling to energetic materials are given including the use of a metal foil as the transfer medium. Effects of temporal characteristics of the laser are discussed. Data from the simulator tests are analyzed to determine ignition delay times and overall function time for the multiple-point ignition system. <i>Key words: simulation; ignitors.</i>						
20. DISTRIBUTION/AVAILABILITY OF ABSTRACT <input type="checkbox"/> UNCLASSIFIED/UNLIMITED <input checked="" type="checkbox"/> SAME AS RPT. <input type="checkbox"/> DTIC USERS				21. ABSTRACT SECURITY CLASSIFICATION UNCLASSIFIED		
22a. NAME OF RESPONSIBLE INDIVIDUAL I. HAZNEDARI			22b. TELEPHONE (INCLUDE AREA CODE) (201) 724-3316		22c. OFFICE SYMBOL SMCAR-IMI-I	

# CONTENTS

	Page
Introduction	1
Preliminary Studies	4
Black Powder Surface Variability	5
The Use of Metal Foils	6
Laser Photonics ND:YAG	8
Ignitor Design	9
Simulator Tests	11
Review of the Phase I Work	14
Early Experimental Work on the Apollo Laser	16
Background	16
Laser/Fiberoptic Coupling	17
Development of the Phase II Primer	17
The Primer Test Setup	20
Apollo Ignition Results	23
The Pellet Surface Reflectivity Problem	25
Metal Foil as the Energy Transfer Medium	28
Laser Photonics, Inc. Laser Specifications	29
Black Powder Ignition, Simultaneity and Laser Pulse Distribution	32
Black Powder Ignition	32
Ignition Simutaneity and Fiber Optic Laser Distribution	35
Ignitor Design	40
Simulator Tests	51
Conclusions	82

Accession For	
NTIS CRA&I	<input checked="" type="checkbox"/>
DTIC TAB	<input type="checkbox"/>
Unannounced	<input type="checkbox"/>
Justification	
By	
Distribution /	
Availability Codes	
Dist	Avail and/or Special
A-1	



## CONTENTS (cont)

	Page
Recommendations	82
Distribution List	84

## TABLES

1	Inert simulator test results	12
2	Live propellant simulator tests	13
3	Apollo ignition data summary	24
4	Laser photonics YNL-100 laser system specifications	29
5	Test data	33
6	M83 center core ignitor specifications	43
7	Fiber systems specifications	54
8	Live propellant simulator tests	59

## FIGURES

	Page
1 System overview	2
2 Phase I laser primer	3
3 Test primer	4
5 General ignitor	7
6 Phase I ignitor design	10
7 Test setup for energy measurements	15
8 Coupling laser energy into an optical fiber	18
9 Integration of trace versus energy	19
10 Initial phase II primer	21
11 Secondary phase II primer	21
12 Ignition test setup	22
13 Reflectance testing	26
14 Reflectance data	27
15 Laser remote control	30
16 Trigger power supply	30
17 Control box	31
18 Test setup	36
19 Optical trace and pressure trace data	37
20 Simutaneity test setup	39
21 Simutaneity of multiple ignition points	41
22 Reusable test fixture	44

## FIGURES (cont)

	Page
23 Configuration 1	45
24 Configuration 2	46
25 Configuration 3	47
26 Configuration 4	48
27 Metal test fixture	49
28 Oxite ignitor-internal pressure	50
29 Verity simulator - 120 mm	52
30 Optical fiber feedthrough diagram	53
31 Laser energy coupling system	54
32 Simulator configuration ignitor placement inert tests	55
33 Simulator configuration ignitor placement live tests	58
34 Inert test, configuration 1 both pressure transducers	61
35 Inert test, configuration 1 front pressure transducer	61
36 Inert test, configuration 1 rear pressure transducer	62
37 Inert test, configuration 1 pressure differential (rear-front)	62
38 Inert test, configuration 1 both thermocouples	63
39 Inert test, configuration 1 front thermocouples	63
40 Inert test, configuration 1 rear thermocouple	64
41 Inert test, configuration 3 both pressure transducer	64
42 Inert test, configuration 3 front pressure transducer	65
43 Inert test, configuration 3 rear pressure transducer	65

## FIGURES (cont)

	Page
44 Inert test, configuration 3 pressure differential (rear-front)	66
45 Inert test, configuration 3 both thermocouples	66
46 Inert test, configuration 3 front thermocouple	67
47 Inert test, configuration 3 rear thermocouple	67
48 Inert test, configuration 4 both pressure transducers	68
49 Inert test, configuration 4 front pressure transducers	68
50 Inert test, configuration 4 rear pressure transducer	69
51 Inert test, configuration 4 pressure differential	69
52 Inert test, configuration 4 both thermocouples	70
53 Inert test, configuration 4 front thermocouple	70
54 Inert test, configuration 4 rear thermocouple	71
55 Live test, configuration 1 both pressure transducers	71
56 Live test, configuration 1 front pressure transducer	72
57 Live test, configuration 1 rear pressure transducer	72
58 Live test, configuration 1 pressure difference (rear-front)	73
59 Live test, configuration 1 all four thermocouples	73
60 Live test, configuration 2 both pressure transducers	74
61 Live test, configuration 2 front pressure transducer	74
62 Live test, configuration 2 rear pressure transducer	75

## INTRODUCTION

Continued development of large caliber shells has placed additional demands on ignition systems. Ideally, the ignition system should be safe, reliable, fast, and offer flexibility in charge design. The development of the prototype of a laser ignited multiple-point ignition system described in this report is part of that effort.

The concept, Soft Ignition System For Self Contained Munitions, involves several ideas. Soft ignition refers to reduction or elimination of axial pressure waves that can occur in conventional ignition systems. These pressure waves can have detrimental effects on the round's performance in terms of propellant bed movement, the destruction of any electronics that may be incorporated into smart projectiles, or in extreme cases, breech damage. A possible solution to this problem is to use a multiple-point ignition system. In a conventional system, the ignition is provided by a center core ignitor tube, such as the M83. In these center-core systems a tube containing the ignitor material and primer is placed in the center of the round and ignited at the base.

The multiple-point system, as its name implies, uses many distributed points to ignite the propellant, the idea being that if enough individual points of ignition can be started simultaneously, rapid flame spread will occur with little or no axial pressure waves. There are other advantages to the multiple-point system. In the conventional center core systems, some evidence exists that indicates as much as half of the ignitor material is unburned when the projectile exits the gun. The multiple-point system, having many ignition points, may require less material to ignite an equivalent size propellant bed. Additionally, the multiple-point system should function faster with internal pressure rises occurring over shorter times. A further advantage is the internal geometry of the round. The center core system limits the length of any projectile penetrators that may be included. The multiple-point system can be configured around any penetrators allowing them to extend nearly to the base of the round.

The other idea to be incorporated in this project is that of laser ignition. The ignition stimulus that is normally provided by an electrical pulse or perhaps a mechanical shock, would now be provided by laser light delivered via optical fibers. There are several advantages to using laser light as the initial ignition impulse. Laser light does not occur in nature, so the system can be made safer. If the materials are made sensitive to the specific laser being used, sensitivity to electrostatic discharge, mechanical shock, and other effects such as EMP can be reduced or eliminated.

Currently available silica optical fibers can carry the required amounts of energy to ignite pyrotechnics. In addition, the fibers are strong and can easily handle the flexing requirements of assembly and

loading. Newer fiber types becoming available have hermetic coatings, giving them lifetimes in excess of 20 years. These factors all indicate that a reliable, fieldable system is possible with currently available technology.

A schematic of the laser ignited multiple-point system is shown in figure 1. For clarity, the projectile and breech interface have been eliminated from the figure. It should be noted that the individual ignitors can be located at virtually any point in the bed allowing greater flexibility with regard to the design of any penetrators or sabots that may be incorporated into the round.

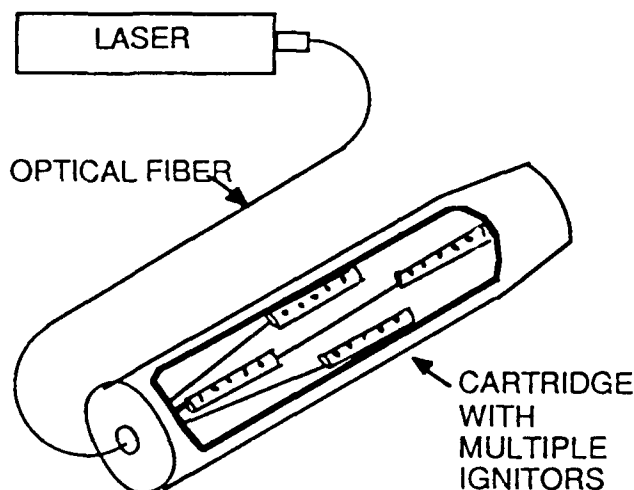

Figure 1. System overview

Earlier work performed during the Phase I effort established the feasibility of using a laser to ignite pyrotechnic material. The result of that effort was the development of a laser/fiber optic primer that was suitable for use in a multiple-point system. A summary of the Phase I effort is given in the technical information section.

The Phase I work demonstrated a laser/fiber optic primer with a function time of  $125 \pm 12 \mu$  seconds. The laser primer is shown in figure 2. It uses lead styphnate as the primer material to ignite a black powder charge.

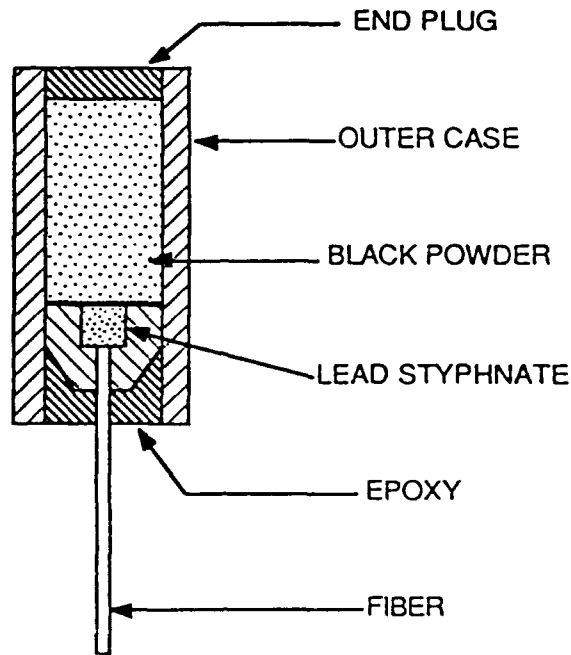

Figure 2. Phase I laser primer

Although the system used in Phase I performed satisfactorily, there were improvements to be made. The primer material, lead styphnate, is shock and electrostatic sensitive. Ideally, a material that is not as sensitive should be chosen. The Phase I system did not attempt to ignite real gun propellants. These factors were addressed in the Phase II project.

This report will cover the Phase II SBIR development effort performed by GEO-CENTERS, INC. It will include the development of the ignitors, the laser system used and the results of the simulator tests performed.

## PRELIMINARY STUDIES

When the Phase II Laser Ignition project started, the only laser available was an Apollo Model 35. This laser is a Nd:Glass which has a normal mode pulsewidth of 250 microseconds. The pulsewidth is not adjustable on this laser. All the early data on the project was taken with this laser as the source.

In order to reduce variability and ease assembly of the primers, standard black powder pellets were used. These pellets are designed as part of a mortar ignition system, and are routinely produced in large quantities. Figure 3 is a diagram of the test primer configuration.

This system represents several advantages over the Phase I primers. The most important improvement is the elimination of the lead styphnate material demonstrating direct ignition of black powder. The casing material is an epoxy tube which holds the fiber and black powder pellet allowing easy, and more importantly, repeatable assembly of the primers. Also, a vent hole has been added to the configuration. Unlike the Phase I primers which cracked or blew end plugs and did not completely consume the black powder charge, the vented primers always burned completely once ignited. Much work was performed to determine the effects of energy and energy density on the functioning of the primers. The results of this data along with details of the work done using the Apollo system is contained in the technical information section. In summary, 3 J of energy in 250 microseconds was sufficient to ignite 100% of the primers.

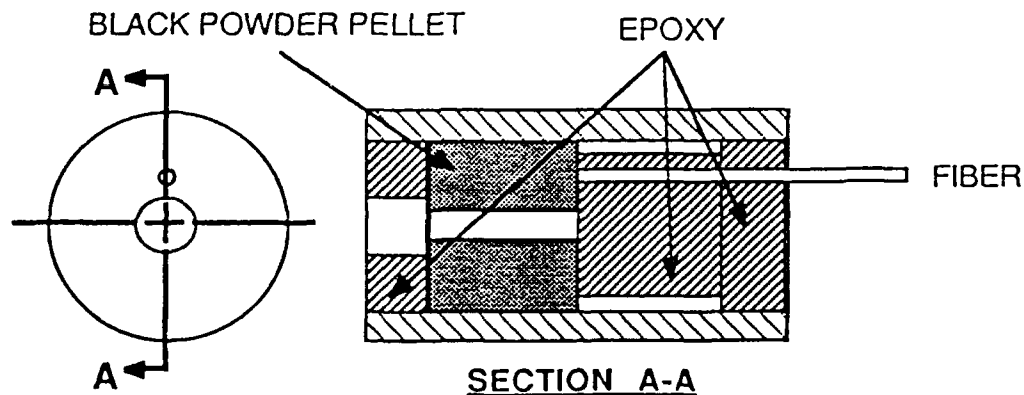

Figure 3. Test primer

## BLACK POWDER SURFACE VARIABILITY

Several months into the project, a new batch of black powder pellets arrived, and when tested, required more energy to reliably ignite them. For example, where 100% of the old pellets ignited with 3 J, only 70% of the new pellets ignited with 3.5 J. The problem was eventually determined to be the surface reflectivity of the pellets. From microscopic examination of the various pellet surfaces, some differences in surface roughness could be seen. An experiment was set up to measure the reflectance to verify this theory. As expected, the reflectivity was significantly different in the two batches of pellets. The differences could be seen from side to side on individual pellets. It was determined that the age and condition of the punches used to make the pellets influence the energy required for ignition. The details of this experiment can be found in the technical information section.

## THE USE OF METAL FOILS

Faced with the problem of variability in surface reflectance, it was determined that a system to eliminate the dependence on surface properties was needed if the laser ignition system was to become useable. Based on other GEO-CENTERS, INC. projects and the work of other colleagues in the field of laser material processing, it was decided to use a metal foil at the end of the optical fiber to transfer the laser energy. The laser energy irradiates the metal foil, rapidly heating and then vaporizing it, and the hot metal vapor (or particles) are used to ignite the black powder. A system like this would eliminate the dependence on the surface properties of the black powder and place the dependence on the metal foil's properties, which should be easy to control.

The metal foils that were evaluated were of aluminum and stainless steel, each 0.0005 inches thick. As an initial evaluation, open shutter photos were taken of laser energy delivered via a 1000 micron core optical fiber impinging on the foils. From these photos it could be seen that the stainless steel had a brighter image than the aluminum with the same input energy and exposure conditions. The fiber jacket material showed a characteristic blue fluorescence (indicating UV light) with the stainless steel foil. These tests, coupled with baseline material processing calculations, i.e., depth of penetration and time constant vs. pulsewidth, indicated that the stainless steel foil would be more appropriate than the aluminum foil.

To test the performance of the foil method, the test primer configuration was modified to include foil between the fiber and the black powder (figure 4). The method proved effective in reducing the amount of energy required to reliably ignite the black powder. For example, the new pellets with 3.5 J of energy delivered via a 1000 micron fiber ignited 70% of the time. The addition of stainless steel foil between the 1000 micron fiber and the pellet gave 100% ignition with only 2 J. Further details of this test and its results are given in the technical information section.

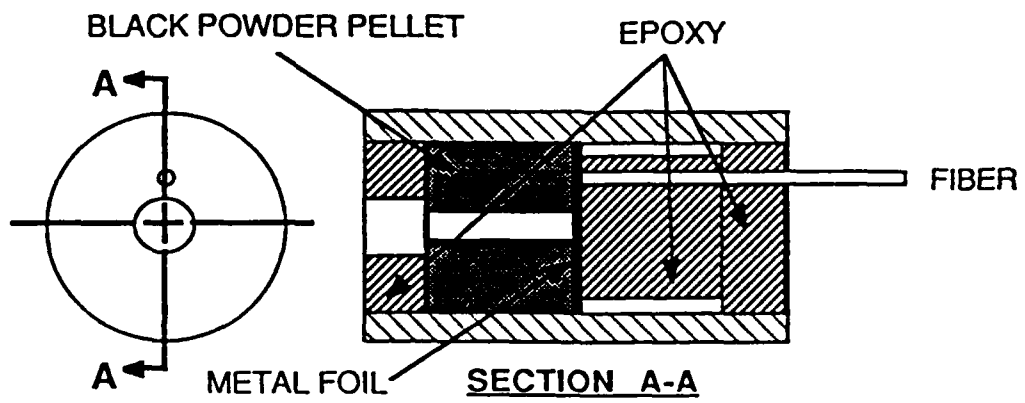

Figure 4. Test primer with foil

## LASER PHOTONICS ND:YAG

A new laser system was acquired for use on this project. Details of its specifications are given in the technical information section. The important difference between it and the Apollo system tested previously is the pulse width. The new laser has several fixed pulse widths--1,2,3 and 5 milliseconds, all of which are much longer than the 250 microsecond width of the Apollo laser. The difference in pulse width between the two systems, the energy requirements and fiber size determinations for the ignition systems under design had to be reevaluated.

The details of the data taken to determine the proper pulse width, fiber size, and energy required are contained in the technical information section. In summary, the pulse width of 1ms was selected because it gave the shortest delay times. A fiber size of 400 microns was selected because it was small enough to be flexible and yet was sufficiently large to allow easy coupling to the laser. At this stage, it was determined that although the longer pulse width laser reduced the ignition threshold, the ignition delay was still too long from the viewpoint of an overall ignitor function time. It was believed that the black powder pellets burned too slowly, and they had to be abandoned. In place of the pellets, class 7 black powder was used. This proved to be sufficiently fast and with the longer pulse width, no foil was needed for reliable performance. The energy required for reliable ignition with the 1 millisecond pulse is 0.3 J (3 x threshold safety factor) for the class 7 black powder. This value is considerably lower than the amount previously needed with the shorter pulse width. This makes the total energy requirement for a full multiple-point system well within the reach of commercially available lasers.

When the parameters for the laser/black powder primers had been established, work began on developing the complete ignitors for the multiple-point system. Initially, it was decided that benite (a mixture of NC and the ingredients of black powder) would be used as the ignitor material. As the project progressed, oxite (a mixture of NC & NG and a large percentage of potassium perchlorate) was also introduced. The benite material is used to ignite M30 propellant. The oxite was developed to ignite new LOVA propellants.

## IGNITOR DESIGN

This stage of the project concentrated on the development of the individual ignitors. This was the final stage of development before testing the multiple-point system. The ignition train starts with the laser pulse, which, in turn, ignites the black powder primer, then the ignitor material and finally the propellant bed. The fiber optic to transmit the laser pulse, the black powder charge and the appropriate ignitor material (Benite or Oxite) are contained in the "ignitors".

The general ignitor configuration is illustrated in figure 5. From the figure it can be seen that the primer maintains contact between the fiber face and the black powder, and allows the flame of the black powder to vent into the spaces in the ignitor material which then ignites. The ignitor casing contains the pressure generated by the ignition which speeds up the reaction. Vent holes in the ignitor housing allow the flames from the ignitor material to vent into the surrounding propellant.

For this project several ignitors were tested. They utilized two types of ignitor materials. Benite was used since it is the ignitor material in the M83 center core ignitor used for M30 propellant. Later, as the project evolved, the problem of igniting LOVA propellant was addressed. This required the addition of oxite as an ignitor material. Several ignitor designs were tried and are described in detail in the technical information section.

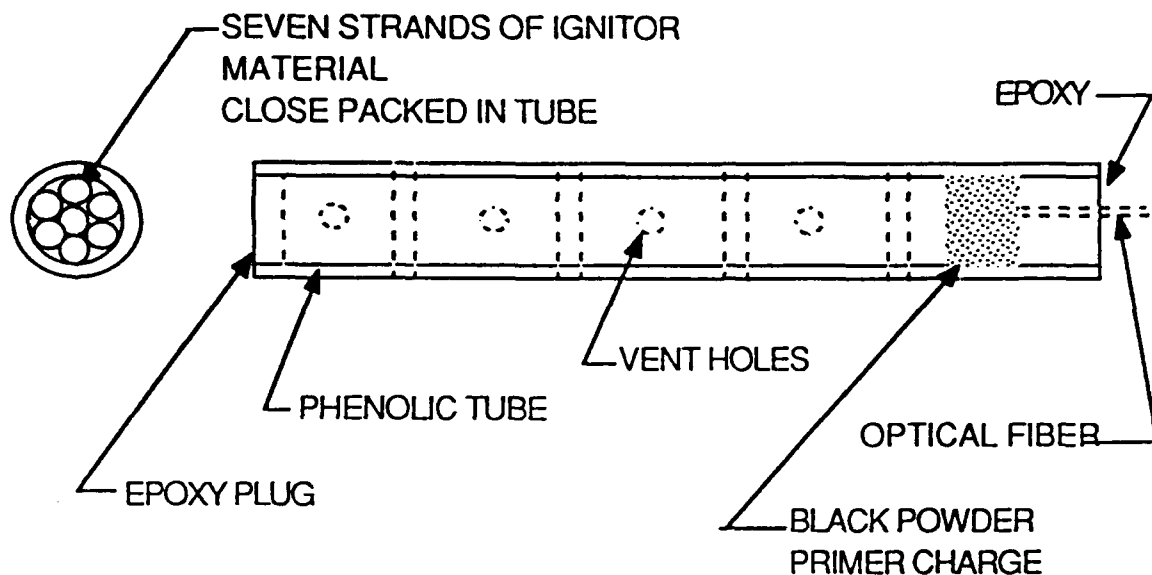

Figure 5. General ignitor

One design utilized existing M83 geometry sectioned into six pieces with Benite as the ignitor material. The second was a slim ignitor that can be used with Benite or Oxite. Both used a reinforced phenolic tube as the case material. A third type is an oxite ignitor that, like the M83 system, employs a metal tube as the outer case. In all cases, the amount of ignitor material used in six ignitors would be the same as in the M83 center core ignition system. The differences are in the geometric configuration and the venting area. These differences lead to different function times and internal pressures and in some cases, primarily in the ignitors employing Oxite, internal pressure could be sufficient to shatter the plastic case material. The shattering of the plastic case material lead to the use of a metal tube as the casing for one configuration of the oxite ignitor because of its greater pressure retaining ability. This configuration displayed the shortest function time.

In order to determine the amount of pressure developed in the ignitors, a test ignitor with pressure sensor ports was designed. The description of the experimental set up to measure the internal pressure is also given in the technical information section along with the test fixture design. From these experiments internal ignitor pressures as high as 7000 PSI (Oxite) were measured.

## SIMULATOR TESTS

The simulator tests involved placing the multiple-point system in a device that simulates the operation of a gun. The simulator used for this project provided information only on the early functioning of the ignition system.

The simulator used for these tests was operated by Veritay Technologies. A detailed description of the simulator tests is given in the technical information section. In summary, the Veritay simulator is a 120 mm cannon shell that is sliced longitudinally reducing the volume to 63% of the capacity of a full round. The part that is removed is replaced with a window for taking high speed movies of the ignition. In addition to the movies, the pressure is measured at two points in the chamber and the temperature at four places.

Inert and live propellant tests were performed with each of the four ignitor types described above. In the inert tests, the multiple-point system was fired in a bed of inert pellets (plastic) that were roughly the same size as propellant grains. The purpose of the inert test is to determine the pressure rise of the ignitors alone. The live tests use actual propellant to demonstrate early ignition properties of the bed.

When the inert tests were conducted with the equipment described above, several experimental problems were experienced. For example, the data acquisition system did not function for all tests, high speed movies were lost during processing and high humidity conditions in the facility caused some of the ignitors to malfunction. Electrical noise was also an additional problem and on occasions, the remote laser logic circuit fired the laser unexpectedly. However in spite of the experimental difficulties and internal malfunctions, the tests still yielded a great deal of useful information. Simultaneity of the pressure rise, which had been targeted at less than 1ms, was demonstrated. The speed of the pressure rise was also as fast or faster than that obtained with the M83 center core ignitor. Table 1 is a summary of the inert simulator results of the two multiple-point tests where data was obtained and, for comparison, data from an M83 primer tested in the same simulator is also included.

Table 1. Inert simulator test results

	M83	Benite	Oxite
Delay Time	7.5 ms	7.1 ms	10 ms
Breach/Projectile. Pressure Rise Diff.	.5 ms	<.9 ms	.5 ms
Peak Pressure	150 PSI	>350 PSI	>350 PSI
0 to 100 PSI Rise Time	6 ms .	6 ms	2.5 ms

Live propellant tests followed the inert propellant tests. These are described in detail in the technical information section. Two were performed with Benite ignitors and M30 propellant, and two with Oxite ignitors and LOVA propellant.

Data and high speed movies were obtained for all tests. In each test, all ignition points functioned. The previously observed humidity problems were avoided by sealing the ignitors before exposing them to high humidity conditions. Results of the tests were encouraging. Delay times were unacceptably long for the M30 propellant; however the pressure rise, once started, was comparably fast. The oxite and LOVA tests exhibited short delay times and very fast pressure rises. The LOVA results were surprising considering the difficulty of igniting this material and its late introduction into the project. A summary of the live propellant results compared with the M83 results is given in table 2.

Table 2. Live propellant simulator tests

Test	1	2	3	4	M83
Ignitor	Benite	Benite	Oxite	Oxite	Benite
Propellant	M30	M30	LOVA	LOVA	M30
Points Ignited	All	All	All	All	N/A
Peak Pressure	2.5 KPSI	2.7 KPSI	3.8 KPSI	2.0 KPSI	2.5 KPSI
Time To Peak	103 ms	141 ms	17.6 ms	55 ms	24 ms
10-90% Time	2.7 ms	2.0 ms	0.8 ms	4.0 ms	2.0 ms
First To Last Ignitor Time	2.1 ms	5.2 ms	2.8 ms	3.5 ms	N/A

## REVIEW OF THE PHASE I WORK

The work done under the Phase I SBIR contract focused on the feasibility determination of an ignition system that would allow multiple-point ignition of a propellant bed utilizing a laser source as the initial stimuli. The system envisioned would make use of a laser pulse conducted through optical fibers that would deliver the energy to the propellant bed. Attempts at direct ignition of the propellant bed via a laser source proved to require prohibitively high energies and exhibited unacceptable ignition delay times; e.g., 5ms or more. Likewise, direct ignition of Benite, the ignitor material presently being used in the M-83 center-core ignitor tube, proved unreasonable. Therefore, in an effort to try to stay within the confines of available technology and currently accepted techniques, it was decided to try a staged ignitor. Since it was known that the standard ignitor (M-83) uses Benite to light the bed, and black powder to light the Benite, the scope of the Phase I effort narrowed to development of a laser/fiberoptic primer that would ignite second stage materials (such as Benite) as well as respond to the laser energy ignition stimulus.

Subsequently, it was found that using lead styphnate as a further interface between the fiberoptic and the black powder brought ignition threshold and delay times to within reasonable ranges, i.e., 1J and 150 microseconds, respectively (see figure 6 for experimental setup).

These results, coupled with further details that may be found in the complete Phase I Final Report, led to the conclusion that this concept held promise as a candidate for further development.

Any discussion of the Phase I effort without mention of the problems or limitations that precipitated during the experimentation proved to be incomplete. These problems or limitations would be of fundamental importance to the progress of a Phase II effort.

Lead styphnate cannot be a final design material in any system that promises increased safety. It is highly sensitive to impact and static discharge and would have to be eliminated or replaced with a less sensitive material. The ignitor test design in Phase I (see figure 6) would have to be redesigned. The testing done with this design measured ignition sensitivity and delay by failure of the case. In a true ignition scenario, the hot gases and particles of the first stage ignition material must be allowed to vent into the second stage material, in this case, benite strands. It would be important to obtain a fast and complete burn of the black powder, as opposed to a casing failure and incomplete burn. Lastly, there is the desired ignition jitter (simultaneity of ignition points). A jitter of about 1ms is the design objective of the Army with respect to the entire ignition system.

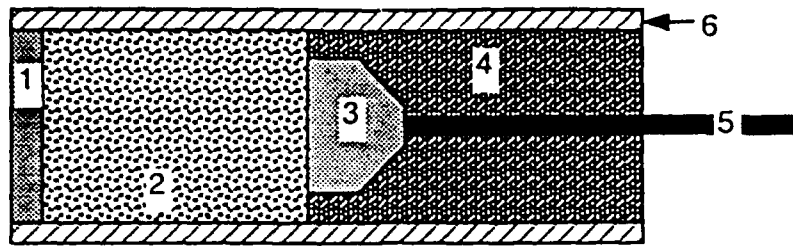

LEGEND

- 1 = EPOXY END PLUG
- 2 = BLACK POWDER
- 3 = LEAD STYPHNATE PRIMER
- 4 = EPOXY BACK FILL
- 5 = FIBER OPTIC
- 6 = TUBE

Note: Overall dimensions are 1/4" O.D. by about 1-1/4" long

Figure 6. Phase I ignitor design

## EARLY EXPERIMENTAL WORK ON THE APOLLO LASER

### Background

The early laser ignition work was confined to the use of an Apollo Model 35 Nd:Glass laser. This laser is capable of delivering up to 200J (Joules) in the normal mode and in the Q-switched mode, 40J in about 25 nanoseconds ( $1.6 \times 10^9$  WATTS). This is not the laser of choice for several reasons. It is physically too large, cannot be easily adapted to the power systems found in a tank, and allows no flexibility with regard to pulse width. Another laser (a Laser Photonics Nd:YAG) was ordered. While awaiting delivery, work was begun on the Apollo. Laser-to-fiber coupling, a primer design (since the Phase I design had to be modified for Phase II work) and initial data regarding threshold energies could be obtained using this laser with final refinement occurring once the new laser was in house.

One of the first goals of the Phase II effort was to eliminate lead styphnate from the primer design because of its impact and static discharge sensitivity. One of the approaches to this goal would be to ignite black powder directly. Work on direct ignition of unconfined (in air) black powder was performed earlier by a group in England<sup>1</sup>. The significance of their work with respect to the present effort was threefold. First, they found that the ignition threshold increases as the beam diameter decreases (this was later found not be the case in a confined system), and that the curves exhibited anomalous dips. It was hypothesized that at certain energy densities, it is possible to generate energetic hot spots where the reactions at the point of laser impingement in the burning material was being rapidly dispersed before continued burning could be established. Secondly, they found that the addition of graphite to the black powder smoothed these dips out and reduced threshold energies by increasing the energy absorptivity at the laser wavelength (1.06u). Lastly, it was determined that as pulse width increased, threshold energies decreased. This information, though not directly applicable to a confined system, was used as a starting point. The Apollo was configured to deliver its longest pulse width, i.e., it was run without the Q-switch delivering a pulse 250us in duration, and only the oscillator was employed as the expected thresholds would be less than or equal to 5 Joules. In fact if the system were to be viable, thresholds of about 1 Joule would have to be attained. Since the system was to incorporate the delivery of the laser energy through optical fibers, it would be necessary to assess the fiber capabilities.

---

<sup>1</sup>"Novel Ignition Systems For Heavy Caliber Guns", C. N. Bowden, G. G. Cook, and P. S. Henning. Royal Armament Research and Development Establishment. U.K. 1985

## Laser/Fiberoptic Coupling

To establish the fiber's capabilities within the realm of what was required, the following experiment, outlined in figures 7 and 8, was implemented. As the laser beam is emitted, the cover slip, acting as a beam splitter, directs some of the energy into the Holobeam photodetector, the output of which is sent to a Nicolet 4094 oscilloscope. The remaining energy passes through the cover slip and falls on a Scientech 362 energy meter. The integrated trace is linearly related to the energy. Representative data showing this relationship is presented in figure 9. The next step was to couple the energy passing through the cover slip into a fiber optic. This was accomplished through the use of a simple lens and the fiber optic mounted on a x-y-z positioner. Using this configuration, a maximum of 10J was transmitted through a 1mm plastic clad silica optical fiber corresponding to energy densities of  $1400\text{J}/\text{cm}^2$  or power densities of  $5.8 \times 10^6 \text{ Watts}/\text{cm}^2$ . These results demonstrated that it would be a fairly simple task to transmit more than enough energy to a candidate ignitor.

## Development of the Phase II Primer

The criteria for the Phase II primer design were that the new primer exhibit the following qualities:

- acceptable jitter levels
- rugged enough to require no special handling
- not fail (crack or burst) during ignition
- allow for the escape of hot gases
- be easily reproduced unit-to-unit
- accept different fiber(s) and sizes.

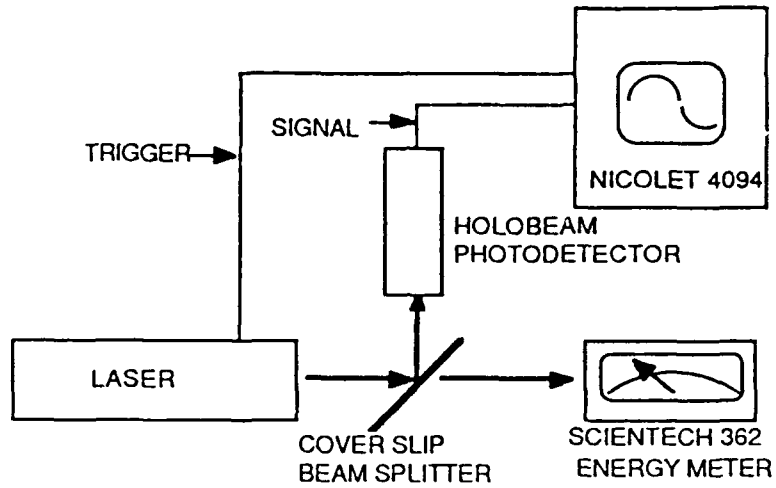

Figure 7. Test setup for energy measurements

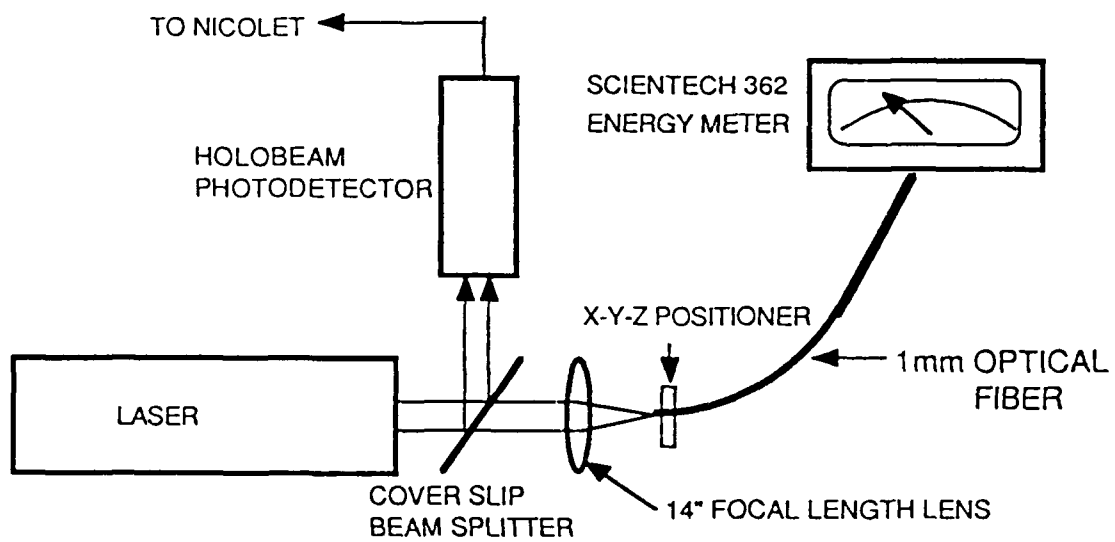

Figure 8. Coupling laser energy into an optical fiber

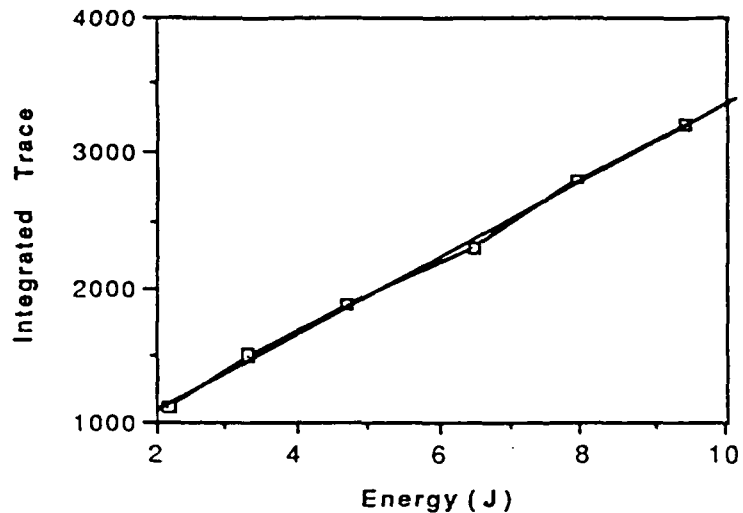

Figure 9. Integration of trace vs. energy

Since the Phase I primer included no way for the hot gases and particulate matter to escape into the second stage ignitor material, a vent hole was introduced. Figure 10 shows the initial design. Its first modification, shown in figure 11, incorporated a way to fix the fiber location more exactly with respect to the black powder pellets. This design also allows for the insertion of a foil interface between the fiber end and the black powder pellet. The significance of these designs is that all the components are basically "off-the-shelf" items. The tubing used for construction consists of precision centrifugally cast epoxy made in sizes that effectively telescope within each other making construction easy and reliable. The black powder pellets fit into the 1/4" size tubing with a close slide fit. The pellets are manufactured with a center hole and coated with graphite. When used with the first design, figure 10, unreliable energy coupling due to the intermittent misalignment of the fiber over a portion of this hole was discovered. The latter design, figure 11, fixes the fiber location at the edge of the first insert tube, thereby ensuring that the full fiber face will be incident on the pellet. The output ends were also polished flat to ensure good energy coupling and no gaps between the fiber and the pellet. This design proved to meet all of the above requisites. General ignitor assembly instructions and a parts lists are included in the ignitor design section.

## The Primer Test Setup

The test setup used to determine threshold energies, ignition delay and jitter values regarding fiber used and energy delivered, as well as set the primer design (above) is shown in figure 12. The Apollo has a trigger output built into its control panel enabling the scope, a Nicolet Model 4094, to be triggered with the pulse, which is sent 100us before the laser pulse begins. The laser pulse was monitored on every shot with the Holobeam photodetector by collecting some of the laser energy through the use of a cover slip as outlined above. The laser beam is then coupled into the fiber of the ignitor through the focusing lens. The fiber goes through a feedthrough into a vented pressure bomb that is fitted with a PCB pressure transducer. The pressure transducer's output is plugged into the appropriate charge amplifier and then to the scope. Ignition delay was measured as the time difference from when the laser pulse trace from the Holobeam reached 100mv above baseline to when the pressure trace from the transducer in the bomb reached 100mv above baseline.

To take data of this kind and ensure its validity, the following procedures were employed before each test:

- Ensure that the Apollo is lasing and is properly aligned. This was accomplished by observing the burn pattern on "zap-it" paper and realignment as required through the use of a coaxial HeNe laser or an auto-collimator or of both.
- Check to ensure that the scope is triggering.
- Check the alignment of beam splitter into the Holobeam photodetector and adjust as necessary.
- Take successive burn spots to ensure that the fiberoptic holder mounted on an x-y-z translational stage is properly located for optimal power coupling (approximately at the point of minimum spot size).
- Depending on what size fiber was used in the construction of the ignitors to be tested, mount a free short length (about a meter) of the same fiber type and size in fiber holder and run the output end to the energy meter (for these purposes a Scientech Model 362).

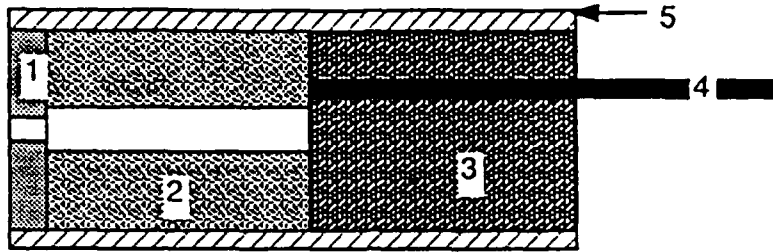

LEGEND

- 1 = EPOXY END PLUG
- 2 = BLACK POWDER PELLETT
- 3 = EPOXY BACK FILL
- 4 = FIBER OPTIC
- 5 = CAST EPOXY TUBE

Note: Overall dimensions are 1/4" O.D. by about 1-1/4" long.

Figure 10. Initial phase II primer

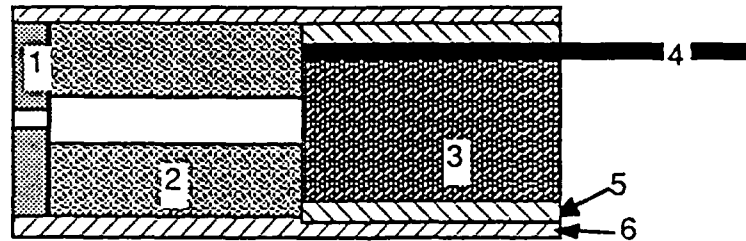

LEGEND

- 1 = EPOXY END PLUG
- 2 = BLACK POWDER PELLETT
- 3 = EPOXY BACK FILL
- 4 = FIBER OPTIC
- 5 = INNER CAST EPOXY TUBE
- 6 = OUTER CAST EPOXY TUBE

Note: Overall dimensions are 1/4" O.D. by about 1-1/4" long.

Figure 11. Secondary phase II primer

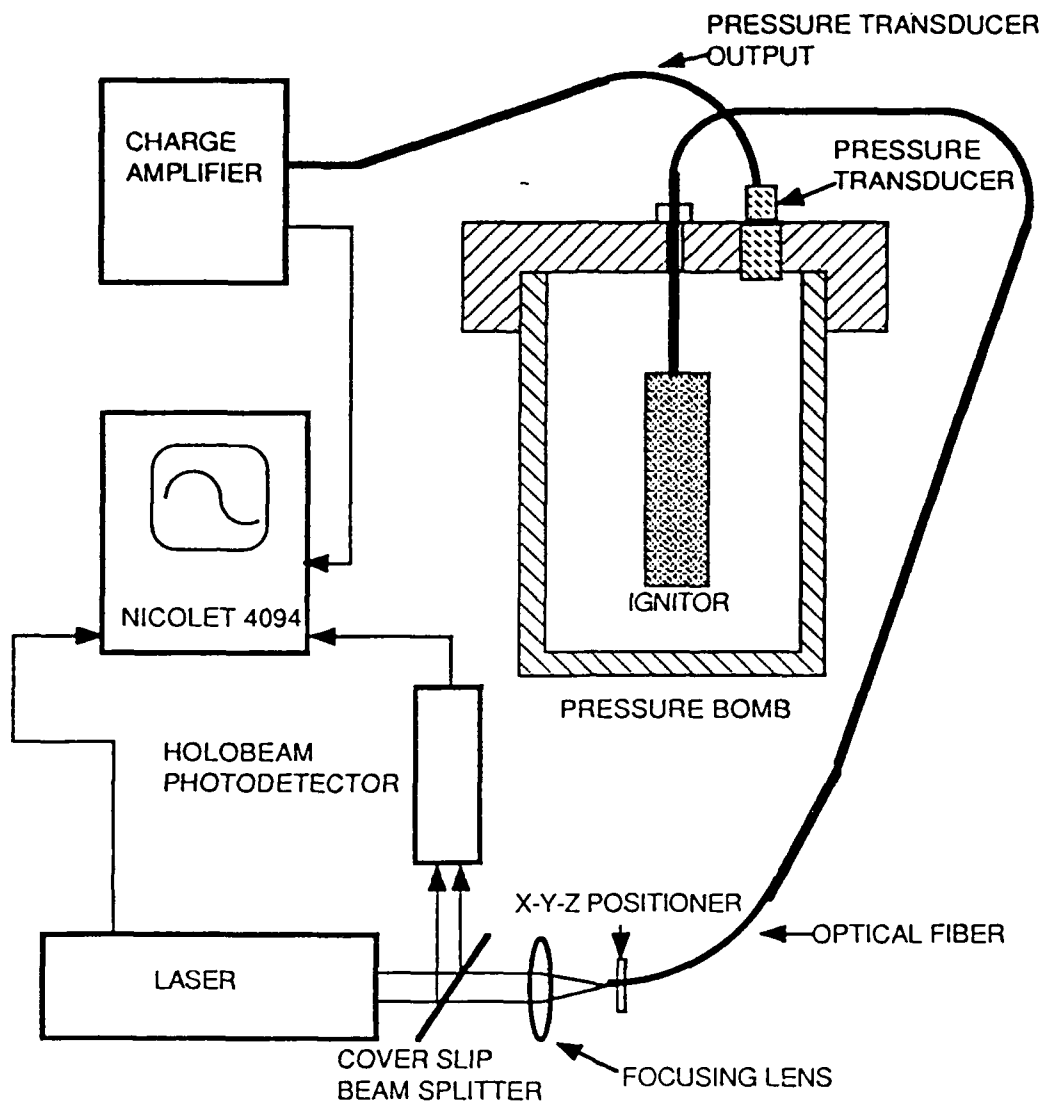

Figure 12. Ignition test set-up

- Measure the fiber output and adjust to obtain the energy level desired by either adjusting the capacitor bank charge or by inserting the appropriate neutral density filter(s) into the beam path.
- Place the primer in the pressure bomb feeding the fiber through the feedthrough in the cover then screw the retaining ring shut.

- Check that the charge amplifier is on and is at the appropriate sensitivity level. Also, check the baseline zero by pressing the full-scale deflection button on the charge amplifier and noticing the trace on the scope (scope set to auto-trigger for this check).
- Replace the free fiber in the holder with the input end of the ignitor fiberoptic.
- Set all scope channels to "Live" and "Hold Next".
- Fire.

Careful adherence to the above procedures ensured that the actual laser energy delivered to the ignitor was known and allowed for the differences in coupling efficiencies inherent in the different fiber(s) and sizes. The traces were recorded on disk and later analyzed for ignition delay as stated above. The primers were also checked to see whether the cases failed in any way and that the pellet was completely consumed.

#### Apollo Ignition Results

The tests were designed to complete a matrix varying fiber size and energy levels to determine which combination yields the optimum ignition delays, jitter values and threshold values. This was started with the Apollo, and completed with the arrival of the Laser Photonics Nd:YAG laser.

Experiments performed with the Apollo demonstrated:

- The achievement of borderline acceptable ignition thresholds, less than 2J (even with the less than optimal short pulse width of 250 $\mu$ s),
- that these thresholds were at an energy level that did not cause destruction of the confining case,
- that jitter levels, less than 100 $\mu$ s, were acceptable,
- that the primer delays were within reason, less than 600 $\mu$ s.
- that the Phase II primer design held promise for interfacing to the second stage material to be introduced, i.e., benite and later oxite.
- the possibility of successfully coupling enough energy to ignite black powder even with fiber as small as 200 $\mu$  core.

A summary of the data taken with the Apollo is presented in Table 3. It should be noted that the difference between "old" and "new" pellets shown on the table relates to their relative reflectivities. This fact presented a fairly significant problem eventually solved by the introduction of a foil interface (the details of the reflectivity problem are discussed in the following section). Only a first blush investigation of the energy density variable (smaller fiber sizes) was begun with the Apollo because the new laser was delivered shortly thereafter.

Table 3. Apollo ignition data summary

<u>Old Pellets</u>				
<u>Fiber Size (um)</u>	<u>Foil</u>	<u>Energy (J)</u>	<u>% Ignited</u>	<u>Delay (us)</u>
1000	NONE	0.5	0	N/A
1000	NONE	0.75	60	472
1000	NONE	1	90	372
1000	NONE	3	100	607
1000	Al	1	100	493
<u>New Pellets</u>				
1000	NONE	1	0	N/A
1000	NONE	3.5	75	452
1000	Al	3	50	N/A
1000	SS	1	0	N/A
1000	SS	1.5	20	550
1000	SS	2	100	449
600	NONE	3	30	500
600	SS	1	0	N/A
600	SS	1.1	30	500
600	SS	1.5	100	560

## THE PELLET SURFACE REFLECTIVITY PROBLEM

The project's initial black powder source was in the form of pellets. These were convenient for a variety of reasons: they were readily available since they are used in mortar initiators; they contain a premeasured amount of black powder and they are easily handled. However, certain inconsistencies between batches do exist. When we used pellets from a new batch (and new lot number), it was found that the ignitors required as much as twice the amount of energy for ignition as ignitors made with the old lot number. For record keeping purposes the associated lot numbers are as follows: old batch: Lot #MA-E-513; new batch: Lot #MA-85J001E168.

It was immediately determined that both lots were manufactured by the same facility with the same formulation. It was hypothesized that there was either a chemical degradation with time or there was a physical difference that affected the energy transfer. Since chemical degradation seemed unlikely and since previous workers had demonstrated the primary importance of surface effects (specifically surface reflectivity) with regard to laser energy transfer, we turned to assessing whether or not there were any physical variations lot-to-lot. It was decided to take photomicrographs of representative pellets from each lot for a physical record and follow these with some form of quantitative reflectance measurements.

Numerous photos were taken through a microscope as well as through a macro lens of the pellets in reflectance. These photos clearly demonstrated the differences between the two lots. The older pellets were more pitted and visually looked duller.

A surface reflectance experiment was setup and is shown in figure 13. A HeNe laser was chopped and sent through a beam splitter. One beam was directed straight to a photomultiplier tube and then on to an oscilloscope for a reference. The other beam was directed onto the surface of a representative pellet which had been mounted over the axis of horizontal rotary stage. This beam was reflected by the pellet surface and then detected by a second photomultiplier tube that had been configured with a slit that would pass only .76 degree half angle of the reflected/scattered beam. The output of this PMT was then also passed on to the scope.

The results of these experiments are summarized in figure 14. The data clearly shows that the optical properties of the pellets are variable, not only lot-to-lot, but face-to-face of the same pellet and, therefore, cannot be depended on to facilitate the laser energy transfer. This work led to the foil experiments and the subsequent incorporation of a thin foil in the ignitors.

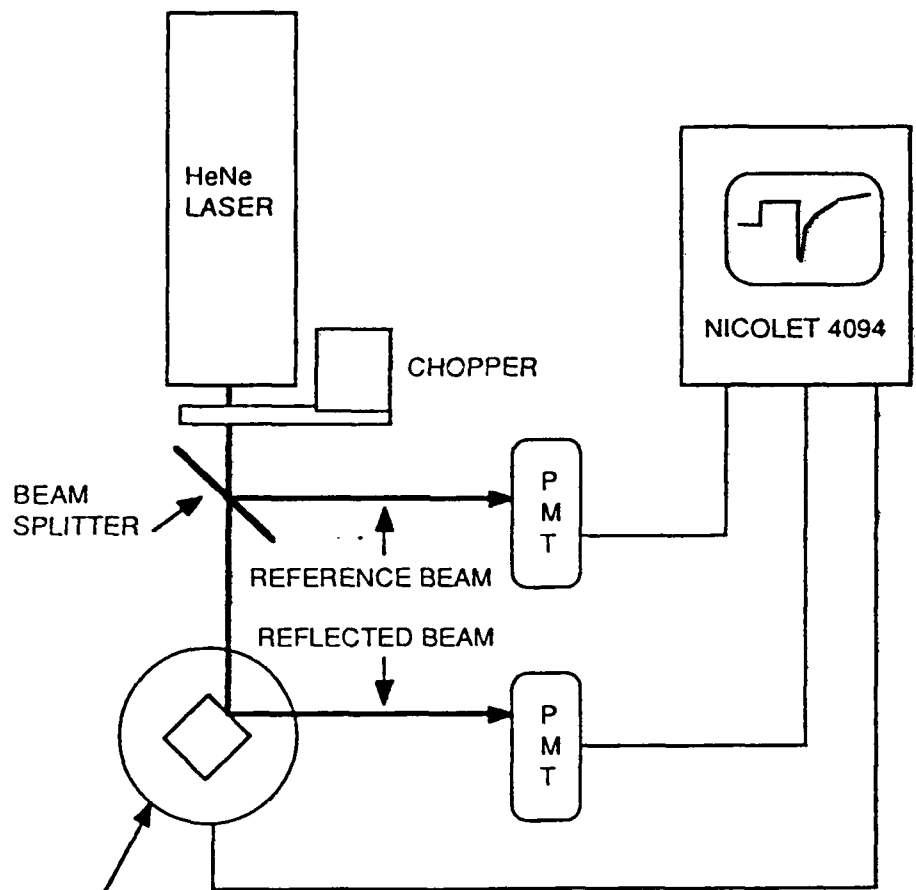

Rotary table mount with pellet to be tested fixed over the table's axis. The table axis was also attached to a potentiometer with one side tied to 5V d.c. and calibrated. This allowed a trace of the angle of the pellet face with respect to the incident beam to be displayed on the scope as well.

Figure 13. Reflectance testing

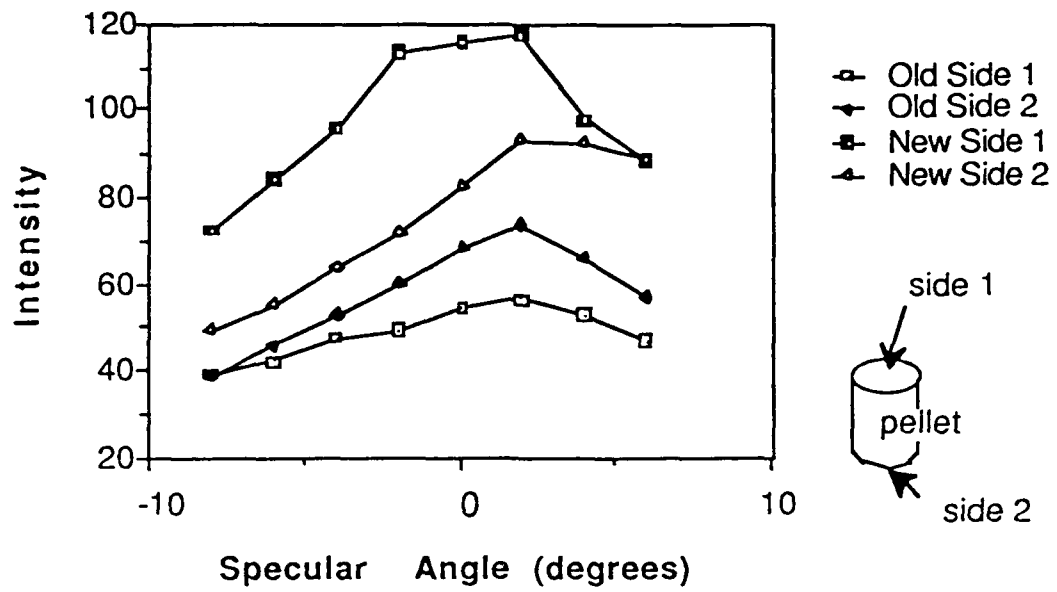

Figure 14. Reflectance data

## METAL FOIL AS THE ENERGY TRANSFER MEDIUM

The use of a thin metal foil as the interface was considered. It became apparent that the surface properties of the black powder pellets affected the reliability and repeatability of transfer of the laser energy. While it might be thought that a metal foil as the energy transfer medium would be more reflective than the pellets, work in the field of laser processing of materials has revealed that metals exhibit very interesting behavior in their ability to absorb infrared energy. Almost all metals exhibit poor absorption of infrared energy at low power or energy densities, ranging from 0.5% to about 10% of the incident laser beam energy. However, at energy densities exceeding  $1 \times 10^6$  Watts/cm<sup>2</sup>, the energy is readily absorbed. Open air experiments were conducted by impinging a given laser energy (in this case about 3J) upon a blackpowder pellet through a 1000u core fiberoptic and then repeating this with a foil interface. The associated energy densities in these experiments at the point of material contact were on the order of  $1.5 \times 10^6$  Watts/cm<sup>2</sup>. It was hoped that by examining the heat affected zone on the pellet surface in the two cases, some information regarding the effectiveness of the foil in improving the energy transfer could be obtained. Stainless steel and aluminum foil interactions were examined in this manner. Attempts at measuring the HAZ of the pellets under a microscope were inconclusive however. Results of open shutter photographs of the laser energy emitted out of the 1000u fiber and incident on the foils alone however, indicated that the particles evolving from the interaction of the laser pulse with the stainless steel foil appeared hotter than those emitted by the aluminum foil. This assumption was based on two observations: 1.) the plume emitted by the stainless steel foil was brighter and seemed to contain more hot particles than the plume created using aluminum foil; 2.) the interactions involving stainless steel foil caused the fiber to exhibit a fluorescence in the visible region of the spectrum which is an indication of the presence of ultraviolet wavelengths or high temperature. These observations, coupled with the fact that given the relative thermal diffusivities ( $0.041 \text{ cm}^2/\text{sec}$  for S.S. and  $0.91 \text{ cm}^2/\text{sec}$  for Al), the thickness of the foil ( $.0005''$ ) and the laser pulsewidth (250us), calculations regarding depth of heat penetration and thermal time constants are more closely matched to stainless steel indicated that improvement of the energy coupling into the black powder through the use of a foil interface, specifically stainless steel foil was possible. Experiments were undertaken to see if this was the case when the foils were employed in the actual ignitors.

Initial tests of the ignitors using foil as the interface for energy transfer were very encouraging. The ignition threshold for the new pellets was lowered, and conclusions regarding the difference in transfer efficiencies between stainless steel and aluminum foils were verified. Included in table 3 is the summary of these results. They indicate that: 1.) the ignition threshold using stainless steel foil is

indicate that: 1.) the ignition threshold using stainless steel foil is at least 1J lower than when using aluminum foil, 2.) by using stainless foil in conjunction with a smaller core fiber, the effective incident energy density is increased, 3.) that the ignition threshold drops down to 1.5J. These data and conclusions were based on the Apollo Nd:Glass laser system and a 250 $\mu$ s. pulse width.

#### LASER PHOTONICS, INC. LASER SPECIFICATIONS

The Laser Photonics, Inc., Model Number YNL-100, was used for the latter part of this project. It is a portable Nd:YAG laser that is packaged in four parts: the electrical power unit, the cooling unit, the laser head, and a line power converter. The power converter is used to convert 110 VAC to 24 VDC, enabling the unit to be used in the field where 22-32 VDC is available. In the event the power converter is not needed. The specifications of the laser are given in table 4.

Table 4. Laser photonics YNL-100 laser system specifications

Wavelength Nd:YAG	1.06 microns
Output Energy	To 13 Joules/pulse
Pulse Rate Frequency	0.5 Pulses/second
Pulse Width	1,2,3 & 5 milliseconds
Beam Divergence	3-4 milliradians
Beam Diameter	6.35 mm
Cooling	Internal
Laser Head Dimensions	21 x 6 x 4 inches
Power Requirements	22-32 VDC, 35 Amps Peak

In order to obtain a trigger signal to start data acquisition and to fire the laser remotely from a safe location, a remote control box was designed and constructed and is shown in (figures 15, 16, and 17). This plugs into the remote control outlet on the laser. It derives all its power from the laser, controls the beam stop, can put the laser in and out of standby, can fire the laser, generates a TTL trigger pulse when the laser fires and will accept a TTL pulse to fire the laser. The remote control introduces a delay of approximately 2.5 milliseconds.

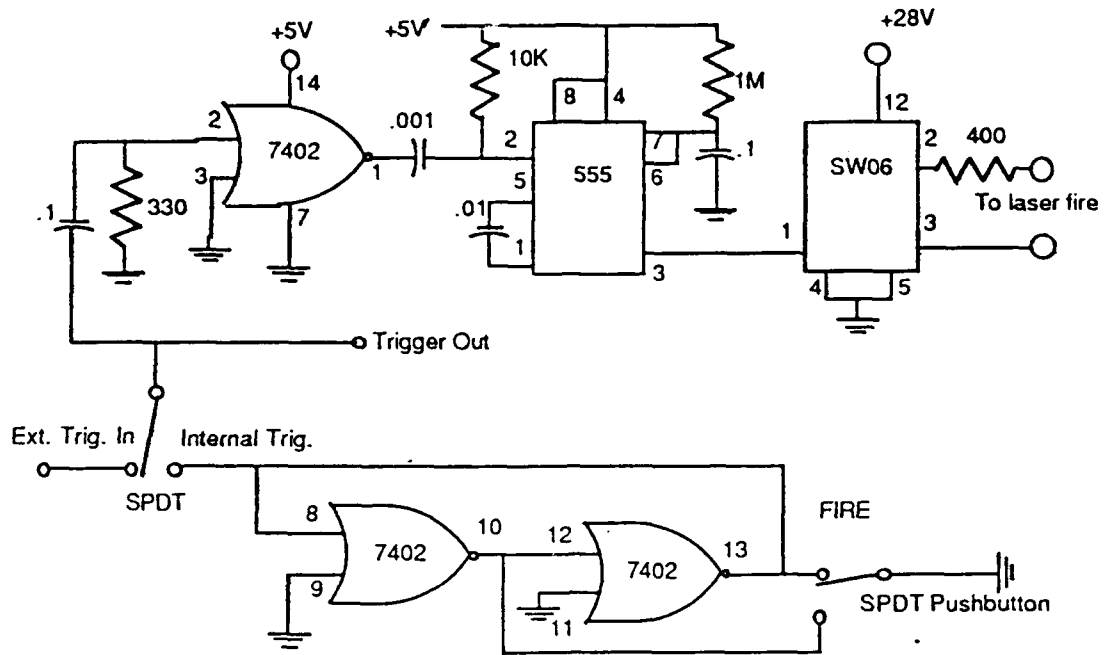

Figure 15. Laser remote control

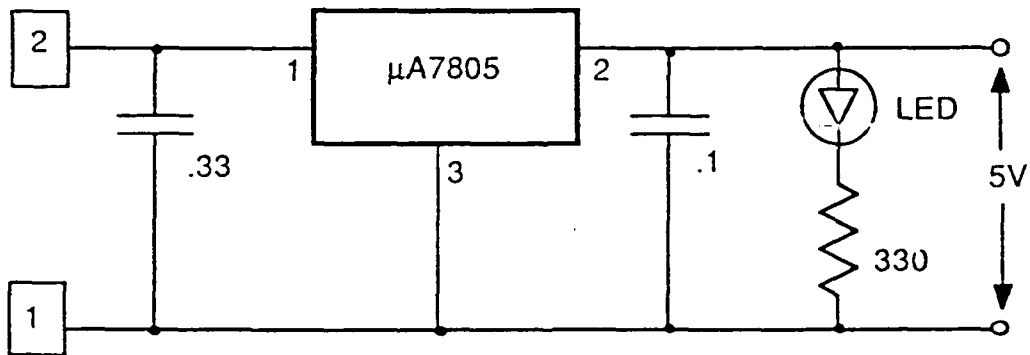

Figure 16. Trigger power supply

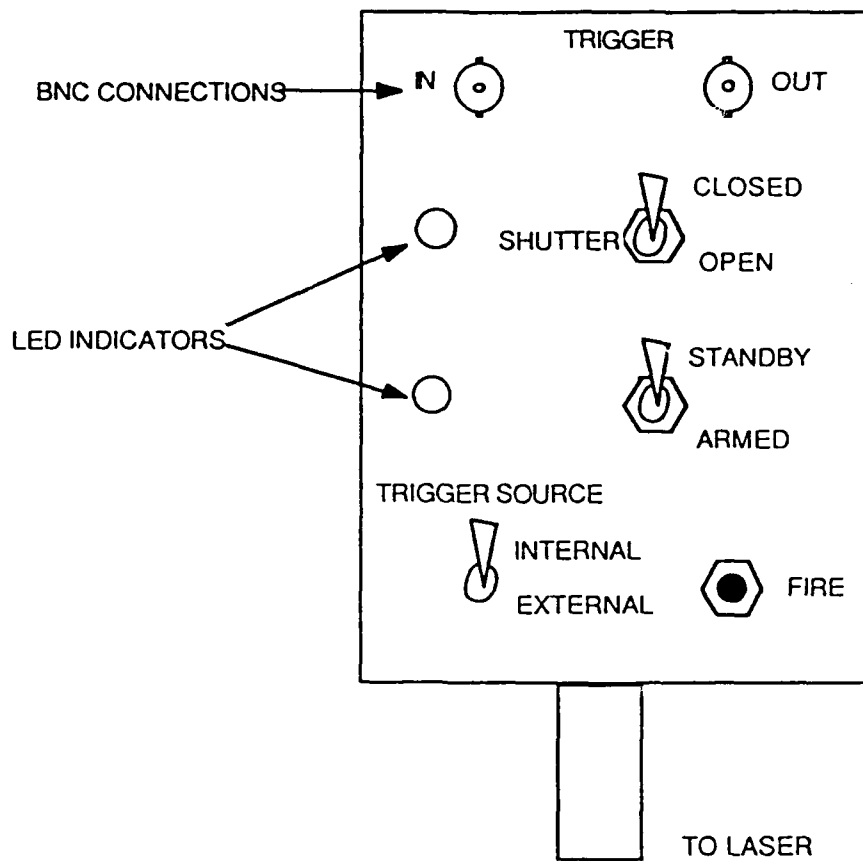

Figure 17. Control box

## BLACK POWDER IGNITION, SIMULTANEITY AND LASER PULSE DISTRIBUTION

### Black Powder Ignition

The Laser Photonics YNL:100 Nd:YAG laser system (described in the previous section) was of critical importance to the success of the project. The YNL:100 offers many of the features that are valuable from a practical sense, i.e., portability, output power, and power requirements. Its most important feature is the provision of longer pulsewidths since the delivery of the laser energy to the material too quickly (short pulsewidth) can create reaction hot spots. If these were formed, the burning reaction occurs with such vigor that the material from the surface is ejected, thereby impeding the further absorption of heat energy created. Previous experience in the field has suggested that for many pyrotechnics and specifically, black powder, a pulsewidth slightly less than 1ms is most desirable. The question of how this impacts on ignition threshold and ignitor jitter are also of importance. The YNL:100 provided the versatility to examine these questions.

Using the primer configuration established with the Apollo system as a standard base with which to make comparisons, a series of tests were made that would basically step through the pulsewidths available (5,3,2 & 1ms), and candidate fiber sizes (1000u, 600u, 400u & 200u) to determine ignition threshold, ignition delay, and jitter. The relevant data from these tests are shown in table 5.

Table 5. Test data

<u>Pulsewidth</u> ms	<u>Fiber</u> <u>Size um</u>	<u>Energy J</u>	<u>% Ignited</u>	<u>Delay ms</u>	<u>Jitter</u> <u>+/- ms</u>
5 ms	1000	0.1	0	-	-
5 ms	1000	0.15	100	18.6	1.5
5 ms	1000	0.2	100	20.1	4.4
5 ms	1000	0.5	100	18.6	1.4
5 ms	1000	1	100	16.3	2.3
5 ms	1000	2	100	23.4	5
5 ms	600	0.5	100	13.7	2.1
5 ms	600	1	100	6.1	0.9
5 ms	400	0.1	100	25.4	3.6
5 ms	400	0.2	100	21.3	2.6
5 ms	400	0.5	100	17.6	3
5 ms	400	1	100	13.1	3
5 ms	200	0.1	100	25.4	5.6
5 ms	200	0.15	100	22.9	6.8
5 ms	200	0.5	100	27.1	3.5
5 ms	200	1	100	18.3	0.2
3 ms	600	0.1	100	27.5	4.4
3 ms	600	0.25	100	27.8	2
3 ms	600	1	100	17.3	0.75
2 ms	1000	0.1	0	-	-
2 ms	1000	0.2	0	-	-
2 ms	1000	0.5	100	22.6	4.1
2 ms	1000	1	100	7.4	1.3
2 ms	600	0.5	100	11.1	7.4
2 ms	600	1.5	100	12.3	2.5
1 ms	1000	0.2	0	-	-
1 ms	1000	0.5	100	18.4	9.1
1 ms	1000	1	100	7.2	1.6
1 ms	600	0.2	0	-	-
1 ms	600	0.5	100	25.4	10.8
1 ms	600	1	100	7.3	1.6
1 ms	400	0.2	0	-	-
1 ms	400	0.5	100	22.8	10.3
1 ms	400	1	100	7.5	2.4

Examination of this data indicated that:

- The ignition threshold for the longer pulsewidths is lower than the same tests done with a shorter pulsewidth. That is, within the energy ranges involved and under confinement, there is an inverse relationship between ignition threshold and pulsewidth. The ignition threshold, regardless of fiber size, lies somewhere below 100mj for both the 5ms and 3ms pulsewidths, whereas for the 2ms and 1ms pulsewidths the ignition threshold is over twice that.

- The ignition delay increased as the pulsewidth is increased. When the length of the delivery period in which a given energy is increased, the time required for the material to reach combustion temperature is also increased. This result is due to some of the initial heat energy of the pulse being lost through conduction.

- Both ignition delay and jitter decrease as energy is increased.

Keeping in mind the fact that these tests were performed under confined conditions (the black powder is confined in the primer tube), within the energy ranges of these tests, no conclusions may be drawn with respect to energy densities. There is disagreement with work done in an unconfined environment by other researchers mentioned in the previous section.

The important points that were derived from this data with respect to a realistic fieldable system (fieldable here means a system that could be tested in a simulator and possibly extended for initial gun firings) are two-fold:

- Since energy density does not seem to be a factor, any possible gains by using smaller fiber from the standpoint of overall system energy requirements are negligible. This means that the primary variables in selecting the particular fiber optic to employ in the system are strength in handling, flexibility and ease of coupling the laser into it. For these reasons 400u HCS (hard clad silica) manufactured by Ensign Bickford was selected.

- A pulsewidth of 1ms was selected as the optimum pulsewidth (within the limits of our system) with respect to the aforementioned trade-offs between threshold, delay, and jitter.

Developments for a laser pulsed system may be summarized as follows:

- A primer configuration has been designed.
- A fiberoptic selected.
- A pulsewidth selected.

- There is an inverse relationship between ignition threshold and pulsewidth.

- There is a direct relationship between ignition delay and pulsewidth.

- Both ignition delay and jitter are inversely related to the energy delivered.

- Within the range of energy densities tested, with all else held constant, energy density does not appear to be a significant factor with respect to ignition threshold, delay or jitter.

As a result, the process of interfacing the first stage primer (black powder charge) with the second stage ignitor material commenced. In this case benite was selected as the second stage material since it is the material in the currently used M-83 center core ignitor tube. This interface design would employ the fiber and pulsewidth chosen to attempt to optimize the entire ignitors functioning. The process of developing the final ignitor design is contained in the following section. It should also be noted that in the process of optimization, it was decided to use Class 7 black powder rather than the black powder pellets. It was determined that the powder form is more sensitive, and has a lower ignition threshold than the pellets thus providing a quicker reaction. These details are also contained in the ignitor design section.

#### **Ignitor Simultaneity & Fiber Optic Laser Distribution**

In any ignition system, it is of critical importance to know the overall ignition system's performance. The multiple-point system, where one of the measures of success is to achieve a uniform flame spread within the propellant bed, the critical system characteristic is the relative simultaneity of ignition, ignitor to ignitor. This type of testing requires that several ignitors of the type described in the following section be initiated from a single laser pulse and that the start of ignition of each ignitor in the test be measured.

It was decided that six ignitors would be fired at a time for comparison. An optical technique was used to determine the onset of ignition for the individual ignitors. Tests were done in a pressure bomb fitted with an optical window and a fiberoptic which was coupled to a photodiode in order to obtain both pressure and optical information of the same event. This was done to ensure that the optical data collected would correlate with the pressure data that had already been collected. The test setup is shown in figure 18 and a sample of the data exemplifying very good correlation between the optical trace and the pressure trace is shown in figure 19.

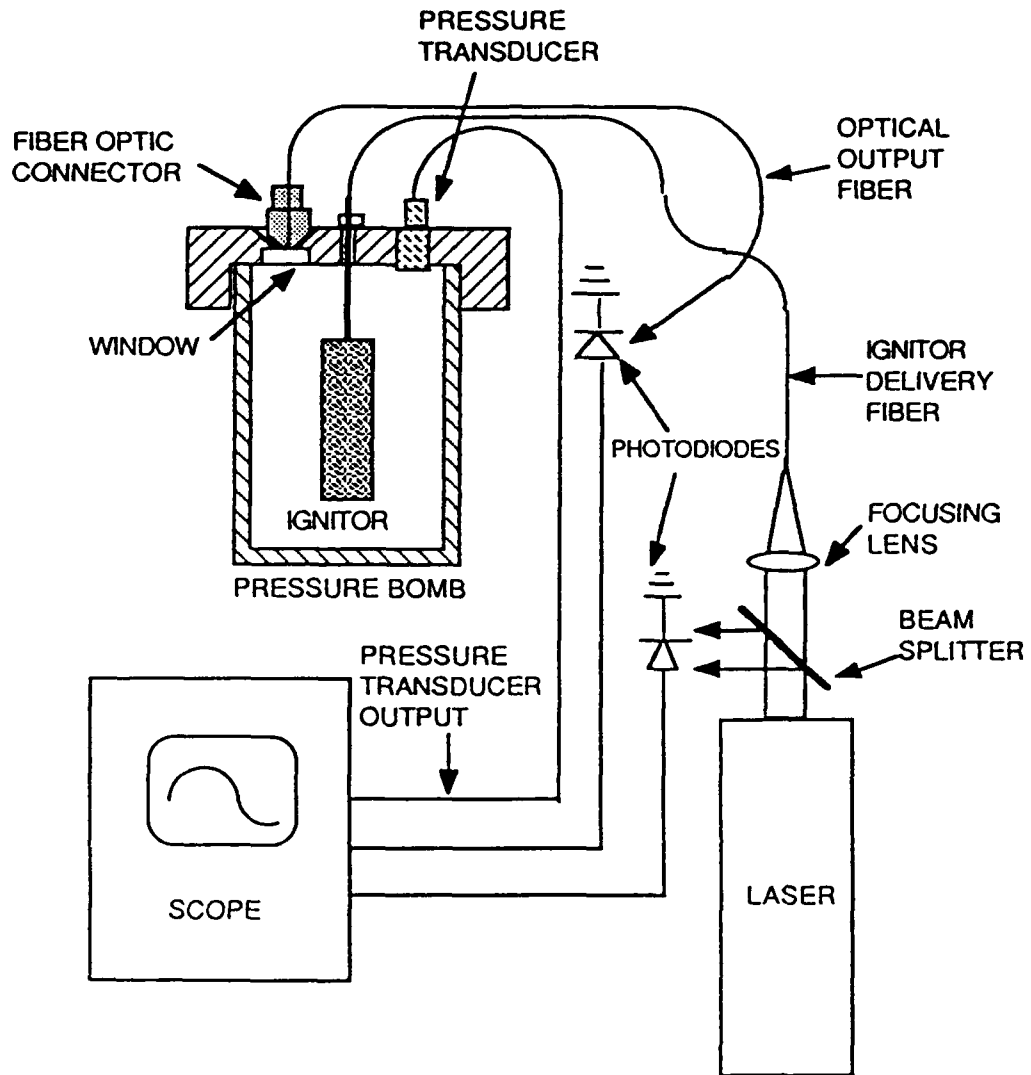

Figure 18. Test setup

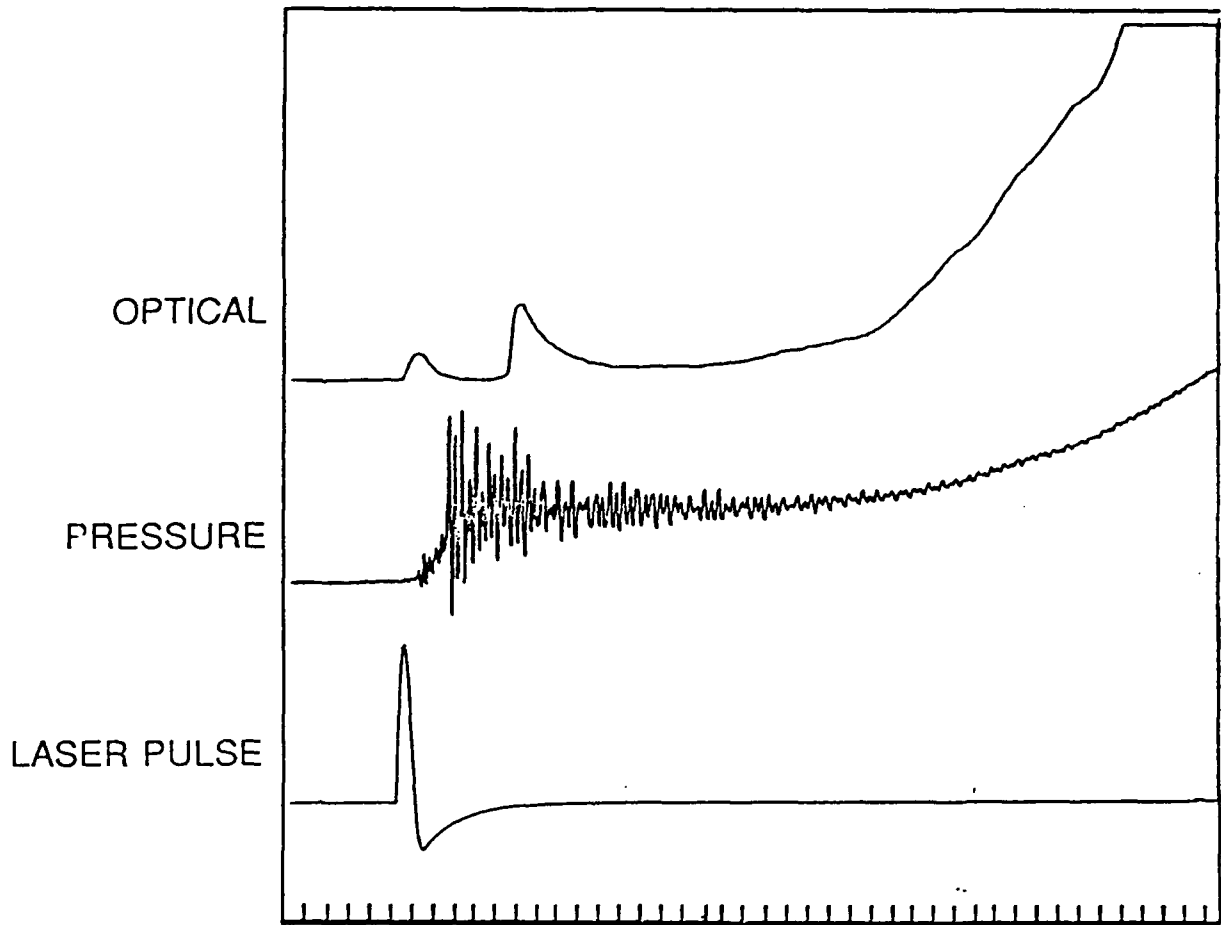

Figure 19. Optical trace and pressure trace data

The technique of obtaining the optical data from multiple ignitor firings was basically the same as above except that a fiberoptic was taped to the side of the ignitor with its face looking at one of the vent holes.

The simultaneity test setup is depicted schematically in figure 20. The tests were done in a way as to mimic the system that would eventually be used in any simulator tests. The laser pulse was first injected into a large core "high power patch cord" constructed of a 1000u plastic clad silica fiber optic that was terminated in standard SMA connectors on both ends and polished using standard polishing techniques (the technique requires that the fiber face, being held perpendicular to the polishing surface, be polished using successively finer aluminum oxide grits, in this case, 15u, 3u and 1u, and then finished using cerium oxide on a polymer lap). Using a patch cord of this type and a 10cm focal length lense, 6J or, for a 1ms pulse, 6000 watts, ( $7.7 \times 10^6$  watts/cm<sup>2</sup> at the output face of the 1000u fiber) from the patch cord could be attained with the laser charged to 75% of maximum. The patch cord was then connected, through a standard splice bushing, to a fiber optic bundle made up of six active 400u core plastic clad silica fibers that was built into a standard SMA connector. An ignitor to be tested was built onto the end of each of the six active fibers in the bundle.

One of the most important parts of both the simultaneity tests and eventually any simulator tests, is the fiber optic distribution bundle. The individual ignitor's function time is energy dependent. It is therefore, of critical importance in this multiple-point system that equivalent energies be delivered to all ignitors and that the overall system performance be efficient enough to deliver at least a multiple of two times the required threshold energy for certainty of system performance.

NOTE: Fiber #1 is always inactive. It is used as a spacer. Depending on the number of ignitors being tested the appropriate number of other fibers are also deadened and used as spacers.



NOTE: The dotted circle represents the 1000u patch cord overlap at the connector to connector interface.

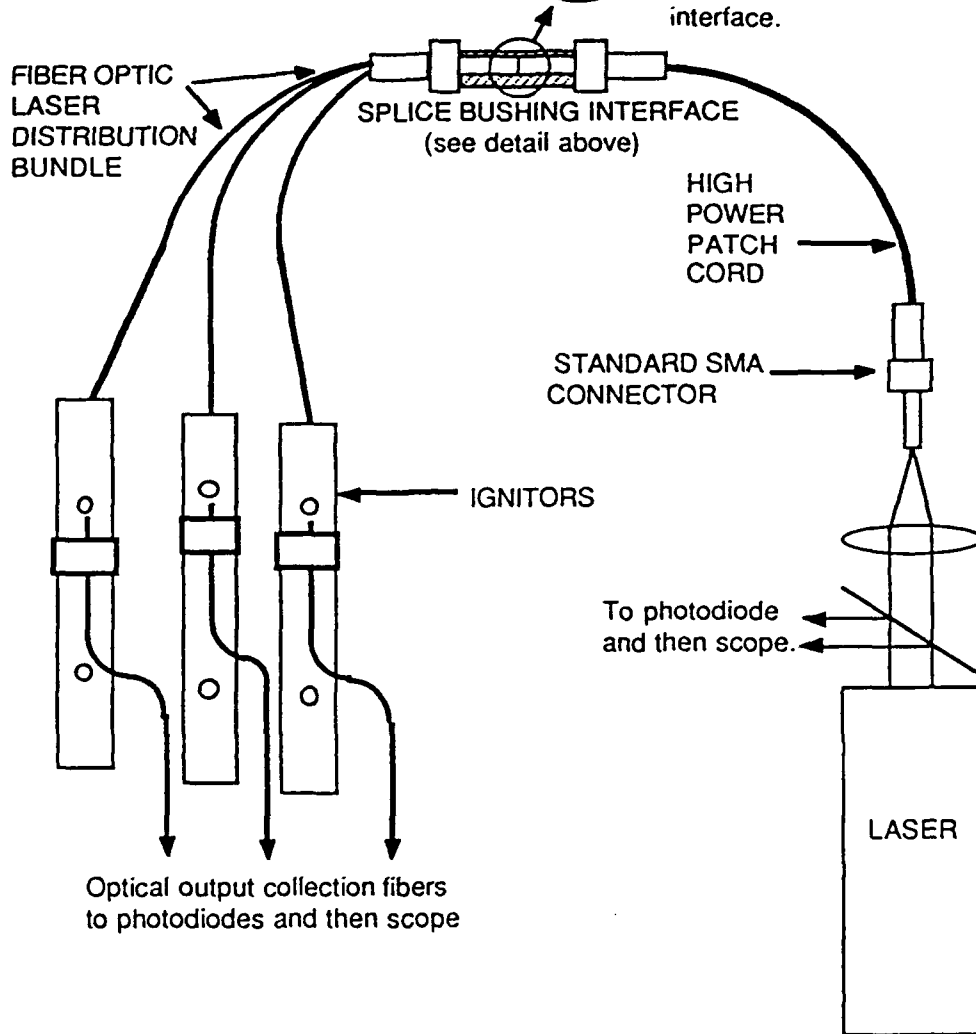

Figure 20. Simultaneity test setup

Theoretical overall system performance calculations were made using worst-case manufacturers' tolerances, data from the tests of the output power of the high power patch cords and standard optical and geometrical considerations. A typical calculation of this type is very straightforward and proceeds as follows:

- Loss through splice bushing (SL) quoted by manufacturer  $\leq 2\text{db}$

$$\text{db} = 10 \log I_i/I_o \text{ where,}$$

$I_o$  is intensity out.  $I_i$  is intensity in, and the ratio times 100 is % transmission. Therefore, transmission through the splice (ST) should be about 63%.

- Packing fraction loss (PL) or the percentage of the area in the distribution bundle that is not core is .33% by:

$$100(P_i(R_b)^2 - N(P_i(R_f)^2) / P_i(R_b)^2 \text{ where,}$$

$R_b$  is the bundle common end radius (in our case equal to 3 times a fiber O.D.).  $R_f$  is a fiber core radius, and  $N$  is the total number of fibers active (let  $N=7$  for this calculation). Therefore, the transmission due to packing fraction is 100-PL or 77%. Note that this should be a conservative number as the overlap as shown in figure 21 is in our favor.

- Losses due to reflections at the surfaces in the splice bushing is included in the manufacturers specified loss, but for our case, an additional reflective loss at the fiber ends in the ignitors must be included; and we make the standard assumption of approximately 4% of the total, yielding a transmission multiplier of 96%.
- The total output from the high power patch cord was expected to deliver:  $.96 \times .77 \times .63 = .466$  or 46.6% to the ignitors for 7 ignitors or fibers.

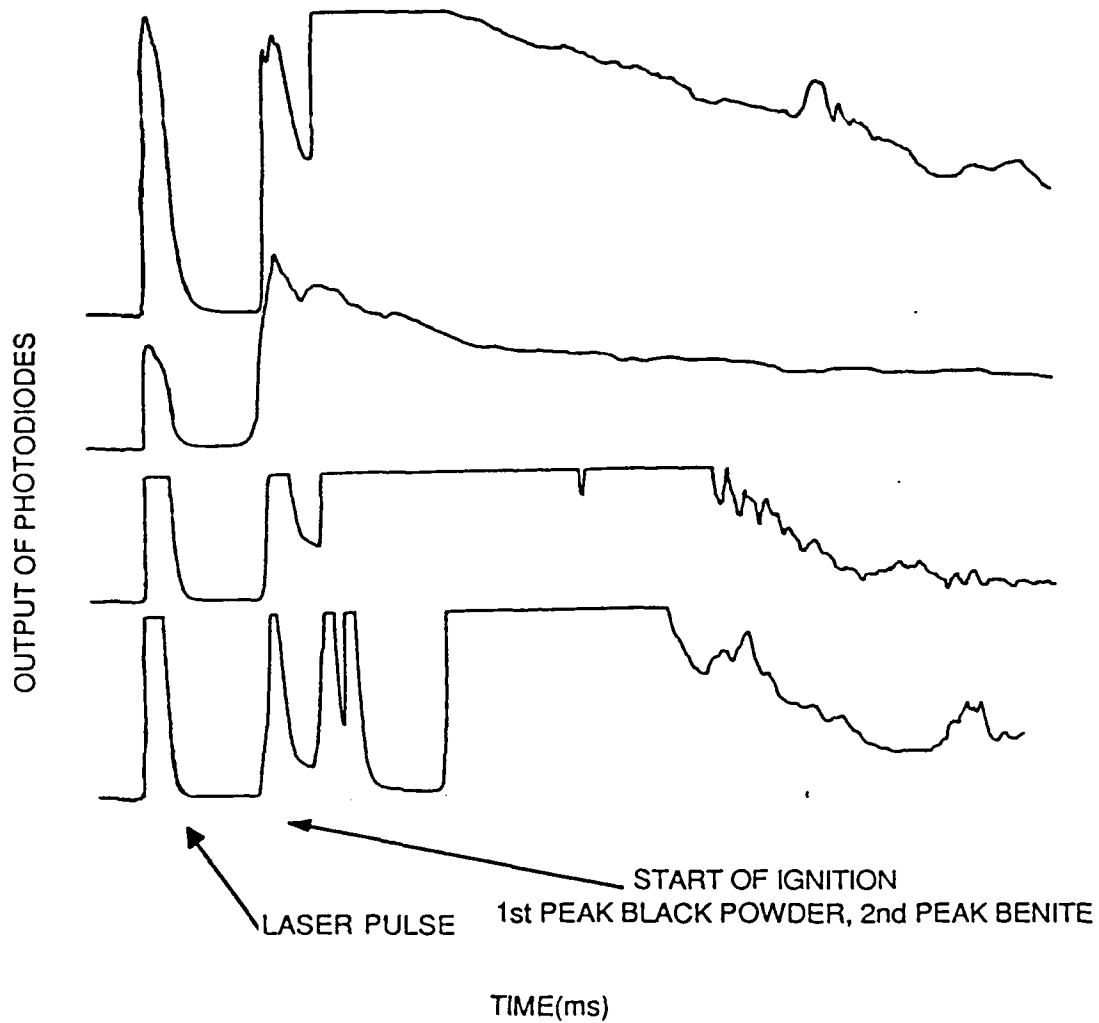

\*Laser pulse delivered at 2.5ms, black powder ignites at 5ms, benite at about 7ms.

Figure 21. Simultaneity of multiple ignition points

23 Tests were made on a system like this to determine the total system transmission. A six (6) active fiber bundle was used since it was decided that 6 ignitors would be of proper scale for the simulator tests that were scheduled. In tests at high power, 8J in 1ms, or 8000 Watts out of the patch cord, collecting all the output from the 6 fibers a overall system efficiency of 45% was measured. When the spacer fiber is accounted for and back calculations are made, the total loss through the splice bushing must actually have been on the order of 1.35db

Prior to the high power testing, representative bundles were tested for fiber-to-fiber variability at lower power, and the percentage transmission of each leg was calculated and compared. The difference from the highest to the lowest fiber was on the order of 2.5%. When these numbers were used in calculations regarding the high power tests, a mean individual fiber output of .49J was measured with a spread of +/- 37.5mJ.

Simultaneity tests of six (6) ignitors at a time were then performed in the lab as shown and described in figure 9.16. Parameters were set so that an average of .5J in 1ms would be delivered to each ignitor. An igniton delay time 5.62ms and a jitter value 1.6ms was measured.

## IGNITOR DESIGN

The major portion of the development of a laser ignited multiple-point ignition system is the individual ignitors. These ignitors will be the ignition points of the system and must contain the optical fiber/primer material interface as well as the ignitor material. The ignitors must contain pressure so that the burning rate of the ignitor material will be sufficiently rapid enough to ignite the propellant.

The current system is the M83 center core ignitor. Its specifications are given in table 6. This system uses a single center core tube filled with Benite that vents radially into the propellant bed. It is designed for use with M30 propellant.

Table 6. M83 Center core ignitor specifications

Size .....	0.5625" ID x 10.125"
Internal volume.....	2.52 Cubic Inches
Venting configuration.....	24 - 0.160" Dia. Holes
Venting area .....	0.4825 Sq. Inches
Ignitor material.....	Benite
Ignitor material Mass.....	32.4 g
Peak pressure .....	4000 PSI

In order to determine the amount of black powder required to ignite Benite or Oxite, a test ignitor fixture was designed and constructed. (Initially, the ignitor material for the laser ignition project was Benite. To compare directly with the M83/M30 system, however, Oxite was added later in an effort to ignite LOVA propellant.) This fixture allowed the optical fiber, with a cap of black powder on its end, to be positioned in contact with the ignitor material and tested. It also had the feature of variable vent holes; that is, the vent holes could be changed by inserting different threaded pieces. The fixture was small enough to fit inside the vessel used to test ignitors and determine their ignition delay. The fixture is reusable, so many tests could be performed to determine the optimal amount of powder. The reusable test fixture is shown in figure 22. Of the tests performed with the test ignitor, 0.06 gm of class 7 black powder was the amount needed to reliably ignite Benite or Oxite in the individual ignitors.

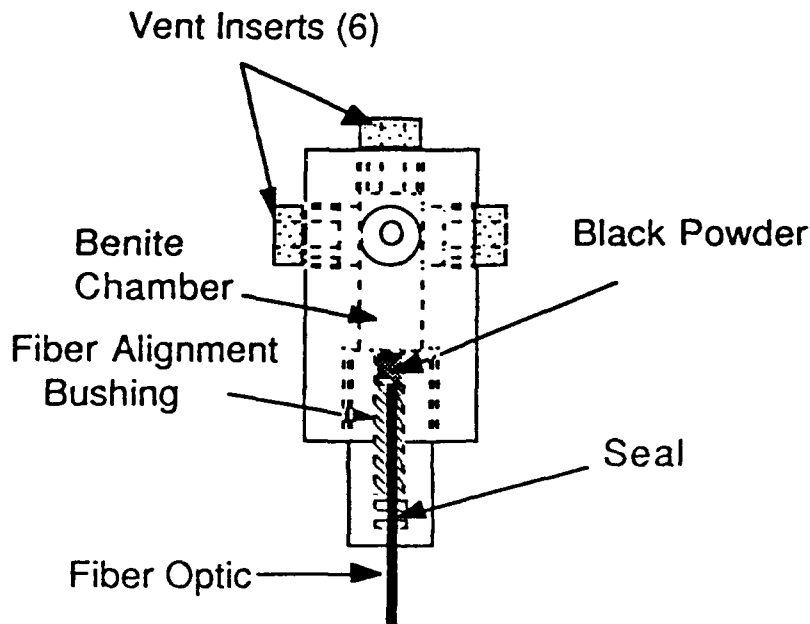

Figure 22. Reusable test fixture

Once the amount of black powder was determined, the actual packaging of the ignitors was the next task. The material chosen for the case was a cloth reinforced phenolic plastic. This material was chosen because it was non-metallic and could mimic the performance that might be expected from combustible case materials. These cases performed acceptably when used with Benite, but when Oxite was used, these cases would routinely fail. In order to obtain Oxite ignitors that would hold pressure, several changes in the basic design were made (see details below). It was decided to develop a metal case design.

Many designs were tried for the ignitors mostly through a combination of varying geometrical configurations and venting areas. For the final simulator tests, four designs were used - two using Oxite and two using Benite. These designs are shown in figures 23, 24, 25, and 26.

The Benite ignitors are shown in configurations 1 and 2 (figures 23 and 24). Configuration 1 contains 7 strands of Benite close packed inside it. This close packing significantly limits void space within the ignitor and allows the pressure to build at a faster rate. Configuration 2 is a system that mimics the M83 center core system except that it has been sliced into pieces. Each piece maintains the M-83 system's ratio of Benite volume to vent area.

The Oxite ignitors are configurations 3 and 4 (figures 25 and 26). Configuration 4 was tried for the same reasons as above because its 7 strands of Oxite are closely packed inside it. The Oxite generated pressure so fast that the case would fail and the Oxite would extinguish itself. To avoid this, the vent area was increased and a small amount of Benite added to raise the pressure at a slower rate. With these modifications the case would hold the pressure and completely burn the Oxite. Configuration 3, the metal case, was used to try and take advantage of Oxite's rapid pressure rise characteristic rather than fight against it. To get maximum advantage from the pressure generated, the metal case ignitors were built with minimal venting. This configuration would prove to be the fastest functioning system.

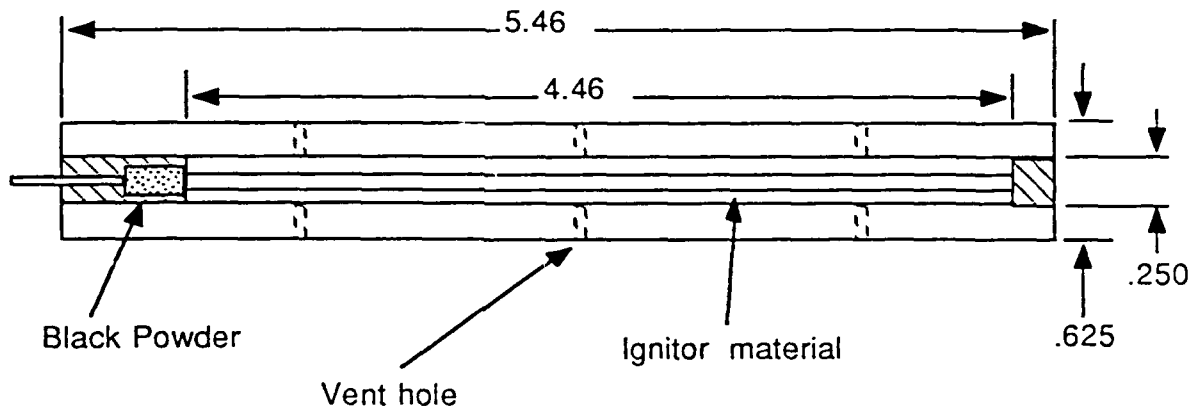

- Tube material ..... Phenolic
- Black Powder Charge ..... 0.06 gm
- Ignitor Material ..... Benite
- Ignitor Charge ..... 4.08 gm
- Venting ..... 12 x .116 DIA
- Vent Area ..... 0.128 sq. in.

Figure 23. Configuration 1

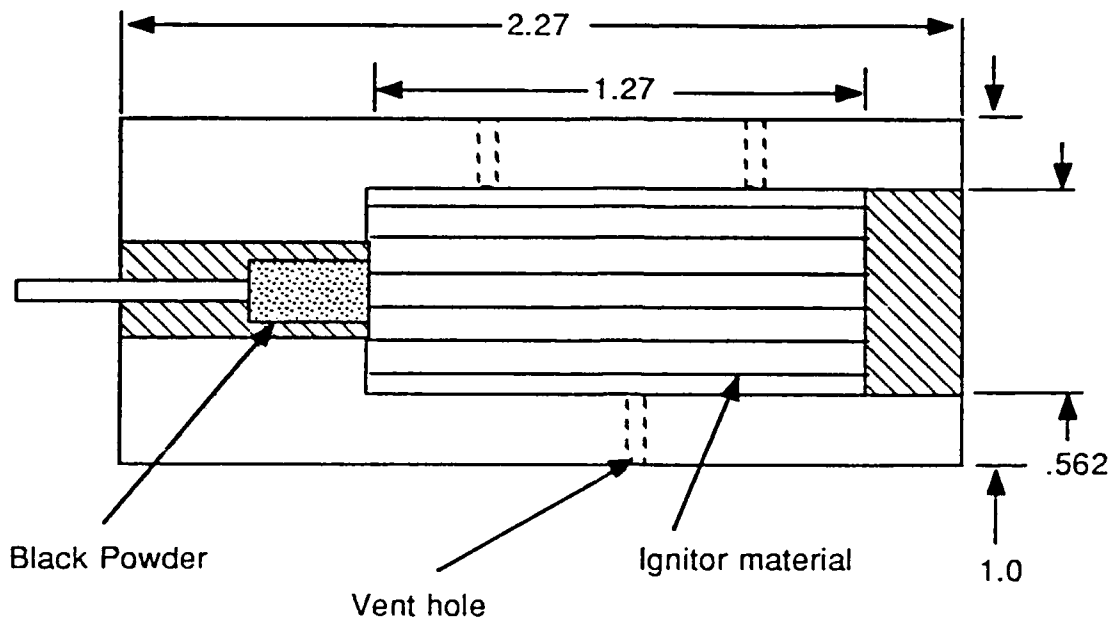

Tube material .....	Phenolic
Black Powder Charge .....	0.06 gm
Ignitor Material .....	Benite
Ignitor Charge .....	4.08 gm
Venting .....	5 x .125 DIA
Vent Area .....	0.061 sq. in.

Figure 24. Configuration 2

The internally generated ignitor pressure turned out to be such an important factor in the ignitor's case design, work was performed to measure the internal pressure of individual ignitors. A metal test fixture containing ports for pressure transducers was constructed that had the same configuration as configuration 1. This fixture is shown in figure 27. Figure 28 shows a typical data trace. From these tests internal ignitor pressures as high as 1500 PSI for Benite and 7000 PSI for Oxite were recorded.

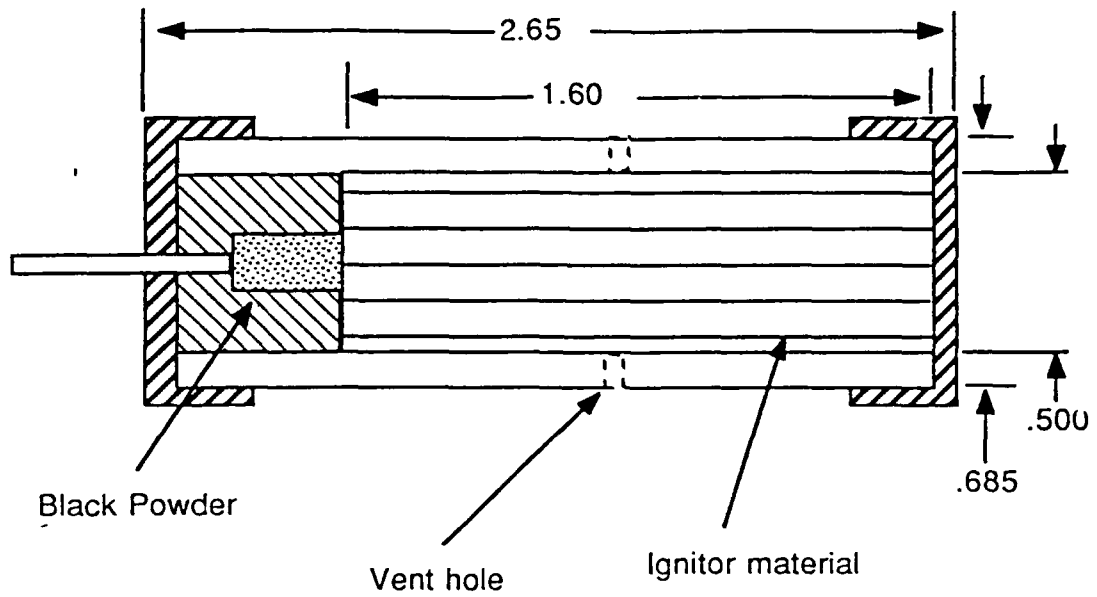

- Tube material ..... Steel
- Black Powder Charge ..... 0.06 gm
- Ignitor Material ..... Oxite
- Ignitor Charge ..... 5.68 gm
- Venting ..... 4 x .139 DIA

Figure 25. Configuration 3

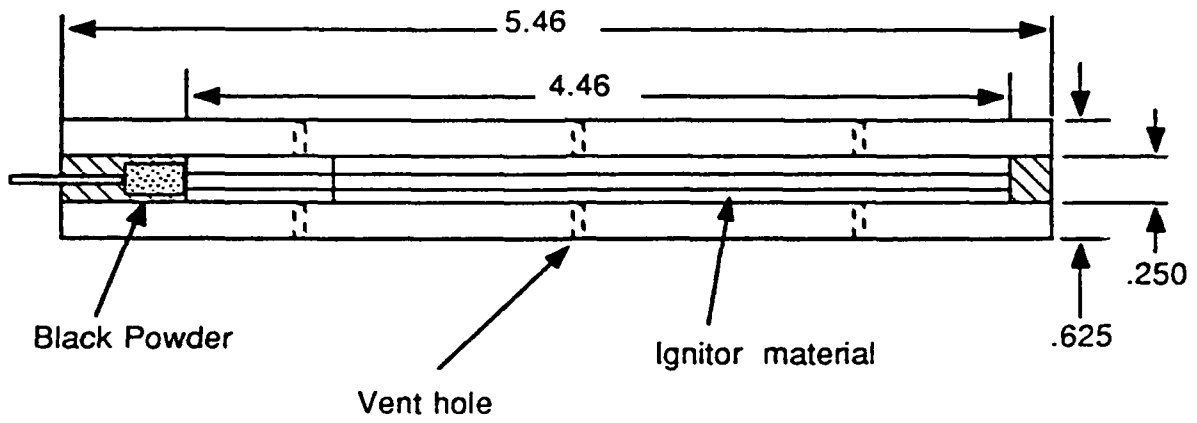

Tube material ..... Phenolic  
 Black Powder Charge ..... 0.06 gm  
 Ignitor Material ..... Benite/Oxite  
 Ignitor Charge ..... 0.82/4.54 gm  
 Venting ..... 14 x .116 DIA

Figure 26. Configuration 4

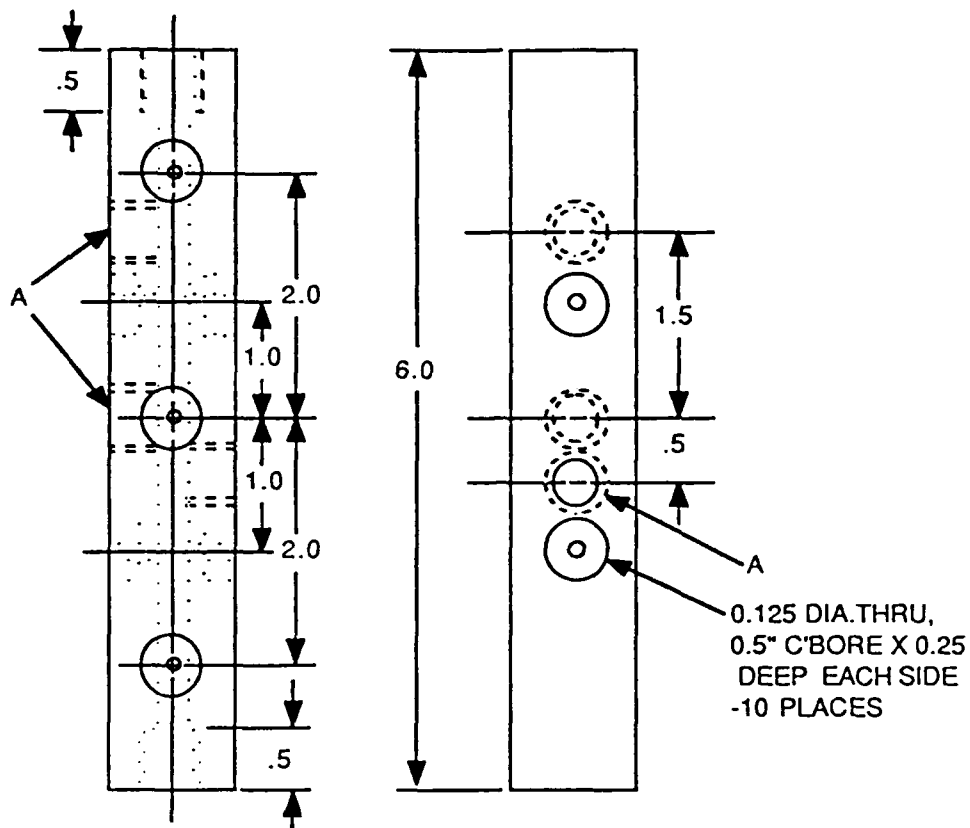

0.125 DIA. THRU,  
0.5" C'BORE X 0.25  
DEEP EACH SIDE  
-10 PLACES

NOTES:

1. MATERIAL: CARBON STEEL.
2. ALL COUNTER BORED HOLES AND TAPPED HOLES NOT SHOWN IN BOTTOM VIEW FOR CLARITY.
3. HOLES MARKED "A" ARE 1/8 - 27 NPT (3 PLACES).
4. ALL DIMENSIONS ARE IN INCHES.

Figure 27. Metal test fixture

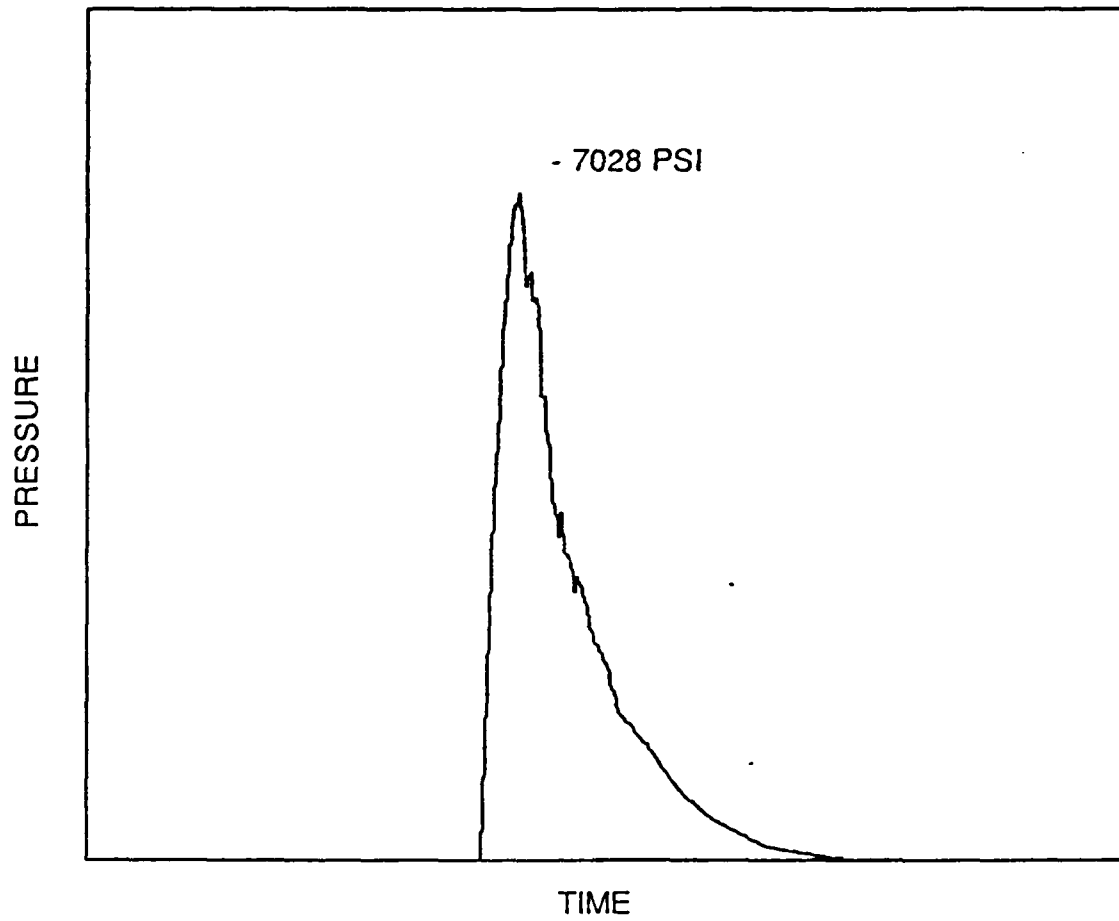

Figure 28. Oxite ignitor-internal pressure

## SIMULATOR TESTS

A simulator was used to test the laser ignited multiple-point system. The simulator was operated by Veritay Technologies, Inc. The Veritay simulator was selected because a standard M83 center core ignition system was previously tested on this simulator, and the data from those tests allowed direct comparison between the M83 and the laser multiple-point system.

The Veritay simulator is based on a 120mm shell, and while this particular simulator does not reproduce an actual gun firing, it does allow investigation into the ignition system's characteristics and the early ignition characteristics of the propellant bed. The fact that the Veritay simulator vents at roughly 5000 PSI precludes that any valid data would be taken concerning complete propellant bed burning. Another informative point of interest that the simulator yields is the presence of axial pressure waves. The Veritay simulator is set up to detect these waves by examining the difference in the pressure at each end of the chamber.

The simulator is basically a 120mm shell that has been cut parallel to its axis so that the volume is 63% of a full round (Figure 29). The removed shell section is replaced by a polycarbonate window sealed in place with a steel plate. This steel plate, which is gasketed and bolted in place, has slots cut into it which allows high speed films to be taken through the exposed polycarbonate window sections. In the end of the round is a polycarbonate projectile that is machined with a taper section that seats the projectile in the round. The simulator also has two pressure ports, one at the projectile end and one at the breach end. It has access of up to four thermocouples allowing pressure vs. time and temperature vs. time data to be taken.

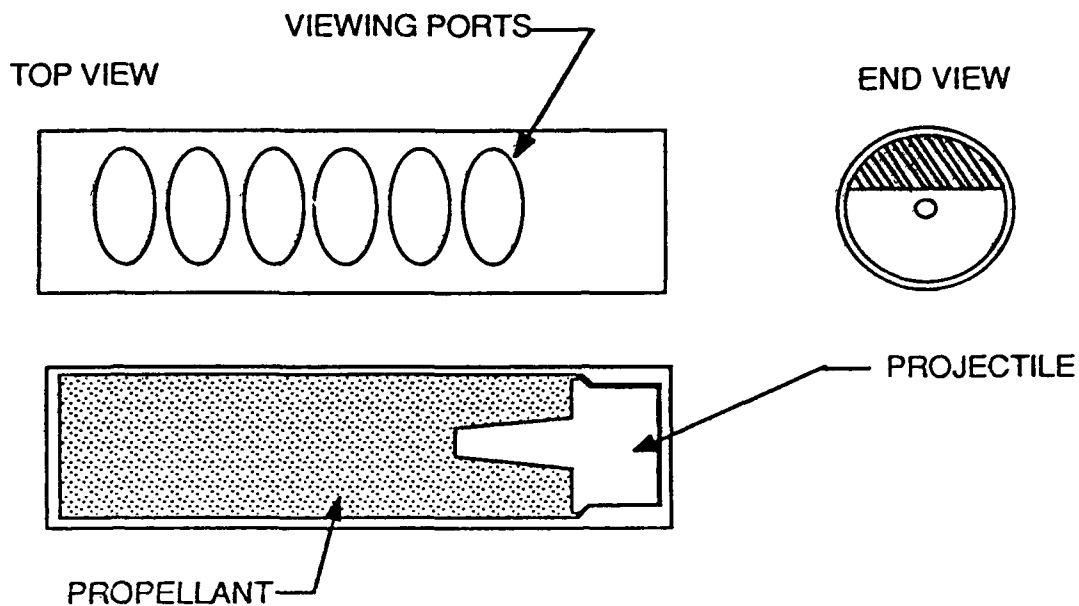

Figure 29. Verity simulator -120 mm

In order to use the simulator, a fiberoptic feedthrough had to be developed that would couple the energy into the ignitors and hold the pressure. Due to the constraints of the simulator, the feedthrough was built into a standard M83 center core base plug. A diagram of the feedthrough is shown in figure 30. It is constructed of standard fiberoptic connector parts that were modified by GEO-CENTERS, INC. for this application. The base plug is threaded to accept a standard SMA fiberoptic splice bushing with an SMA connector installed internally. The internal connector is modified to accept the required number of fibers (maximum of seven) needed for the multiple-point system under test. The base plug is then back filled with an epoxy that seals the system.

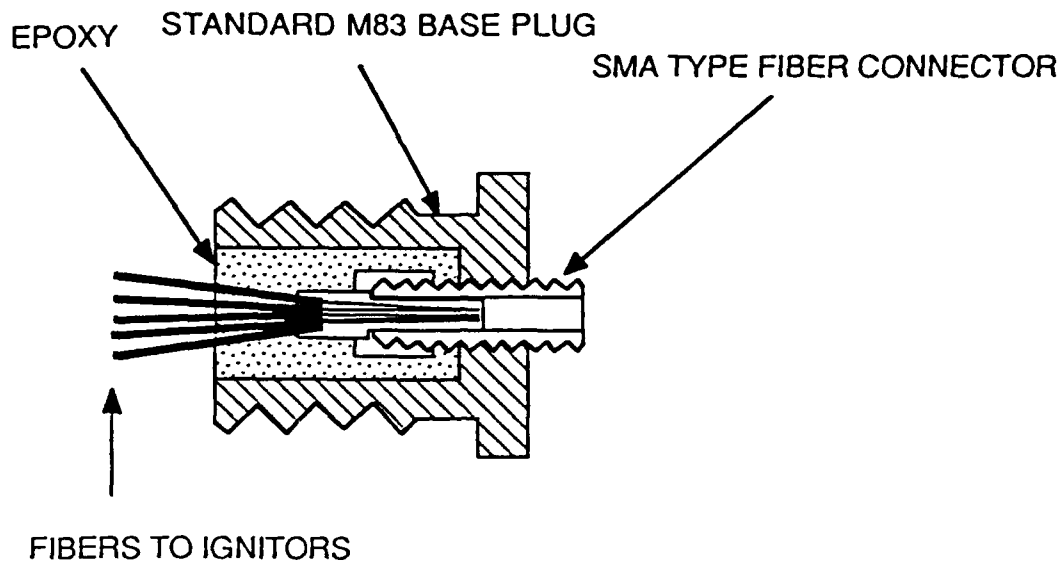

Figure 30. Optical fiber feedthrough diagram

A block diagram of the complete system for coupling the laser energy into the simulator is shown in figure 31. To operate the simulator, the ignition system is installed first through the base pad, then the base plug is screwed into position. The required transducers are fitted and/or positioned while filling the shell chamber with propellant. The rest of the simulator is assembled, and a fiberoptic patchcord from the laser is plugged into the outside of the SMA splice bushing that is protruding from the base plug. For these tests the patch cord consisted of 5 meters of 1000 micron core plastic clad silica fiber. The laser/patchcord system is capable of reliably delivering over 8 joules of energy in a 1 ms. pulse to the ignitor system. Coupling and other system losses reduced the actual energy delivered to the ignitors but in no case did this fall below .35 joules for a system with up to 7 ignitors. A summary of the fiber delivery system is given in table 7, and further details can be found in the laser pulse distribution.

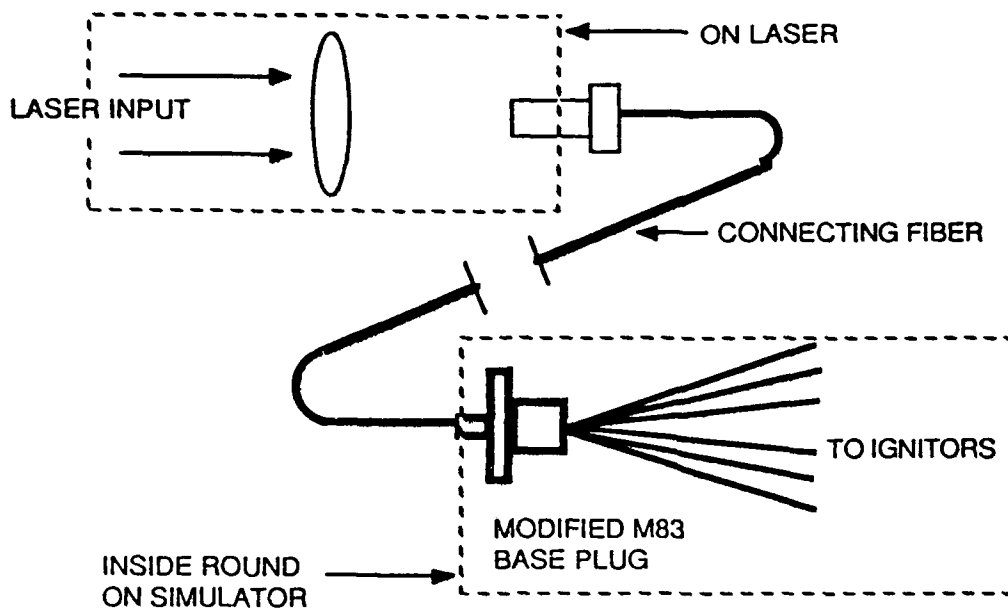

Figure 31. Laser energy coupling system

Table 7. Fiber systems specifications

Connecting Fiber Type	1000 $\mu$ m PCS - 5m Long
Fiber Connections	SMA Compatable
In Round Fiber Type	400 $\mu$ m PCS
Energy per Ignitor	.75 Joules Typ. (.35 min.) 1 ms Pulse
Number of Ignitors	7 Maximum
Output Energy Density	595 Joules/Sq. cm Typ.

Two sets of simulator tests were performed - one set using inert propellant and the other set using live propellant. The inert tests consisted of the ignition system in a bed of inert plastic pellets. The purpose of the inert tests is to examine the functioning of the ignition system. These tests show how fast the ignitors functioned, how much pressure was generated by the ignition system, the degree of simultaneity and if all of the ignitors burn completely. The inert tests allow a chance to "shakedown" the system before the considerably more dangerous live propellant tests are performed. This turned out to be extremely important since during the inert tests, many problems were encountered. Several tests had severe data acquisition problems; i.e., transducers not functioning properly, incorrect timing, no high speed movies were obtained; and due to severe electrical noise at the Veritay test facility, the laser fired with no input signal from the control system. High humidity conditions in the test bunker adversely affected some of the ignitors.

Five ignitor configurations were tested with inert propellant. The configurations as shown in figure 32, are described in the ignitor design section, except that the amount of ignitor material was 30gm (the amount found in a full M83, not scaled down to 63% to correlate with the simulator volume).

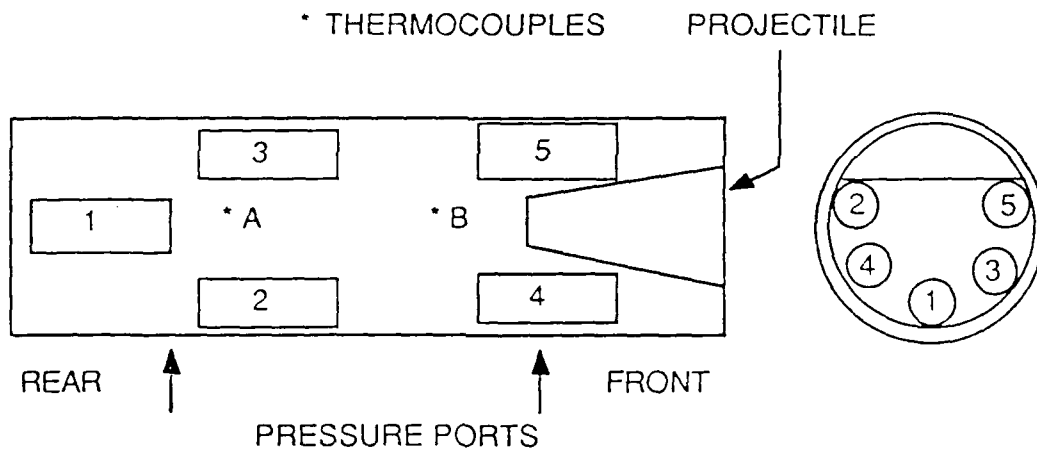

Figure 32. Simulator configuration ignitor placement inert tests

The following results were achieved:

A six-ignitor system using benite (configuration 1, figure 23)

- Excellent simultaneity between breach and projectile end pressure traces. Jitter of .95ms.

- Peak pressure of approximately 350 PSI was attained, at which point the projectile was ejected.
- Pressure attained is approximately 3X pressure developed during an M-83 test.
- The projectile exited simulator at ~44ms. (Of interest is the fact that M-83 inert tests do not "blow" the projectile).
- The high speed movie was underexposed.

A six-ignitor system using benite (configuration 2, figure 24):

- No data acquired.
- Projectile did "blow".
- Four of the six ignitors ignited.
- 200 mJ of energy per ignitor
- The high speed movie was underexposed.

A three-ignitor system using benite (configuration 1, figure 23):

- This test was performed to see if M-83 type pressure rises could be attained using less material.
- One of three ignitors ignited.
- Projectile did not "blow".
- The high speed movie was destroyed in processing.

Poor results of the second and third tests indicated a possible problem with the ignitors. It was hypothesized that the high humidity in the test facility (room temperature was about 48° F with >75% relative humidity) was affecting the black powder charge in the first stage of the ignitors. The fourth and fifth tests as outlined below were done after overnight drying of the systems in a 40°C oven and then immediately wrapping the individual ignitors in plastic film upon removal from the oven.

A six-ignitor system using oxite (configuration 1, figure 26):

- All points ignited (two cases failed).
- Projectile "blew".
- Long delay was observed, ~360ms.
- Peak pressure observed was again roughly 350PSI before the projectile "blew".
- The high speed movie was destroyed in processing.

A five-ignitor system using oxite (configuration 3, figure 25):

- All points ignited.
- Projectile "blew" at ~46ms.
- Delay observed was ~10ms.
- Simultaneity was within the resolution of the data acquisition, 5ms.
- The high speed movie was destroyed in processing.

Among the ignitors that functioned, the simultaneity was good and the delay times, although long for test 4, were compatible with the M83 for tests 1 and 5. Comparison of data on the M83 system with inert propellant in the Veritay simulator show that the M83 system exhibits an ignition delay of 7.5ms, while Test 1 of the multiple-point system shows a 7.1ms delay and Test 5 a 10ms delay. Comparing the peak pressure of the multiple-point system with the M83 is not accurate since the M83 data was taken with a 63% load of ignitor material while the multiple-point system used full loading. The multiple-point tests were not scaled down with respect to ignitor material explains why the multiple-point system ejected the projectile and the M83 system did not. The data traces for the inert tests are included at the end of this section along with the ignitor placement.

This procedure for live propellant testing ensured that the tests were done properly, that data is taken and that safety procedures are observed. The operating procedures are included at the end of this section. The laser was fitted with an electrical transient suppressor to prevent inadvertent firings and the remote control cable was lengthened to reach the control room so that all personnel could be out of the test area before the laser is armed.

The live propellant tests were performed as planned. Data was acquired properly, high speed films were taken and developed properly and the laser functioned without problems. Four tests were done - two

with M83 propellant and two with LOVA propellant. The configurations were those described in the ignitor design section, with the placement of the ignitors, pressure transducers, and thermocouples shown in figure 33. The amount of ignitor material used was scaled to 63% of a full up charge, so direct comparison of data with M83 results is reasonable.

The data from the live tests is given at the end of this section (figures 34 - 74), with a summary in table 8. This table contains the results of a standard M83 center core ignitor used with live propellant in the Veritay simulator. Tests 1 and 2, using benite ignitor material and M30 propellant, had very long delay times indicating that a faster action time is needed. This is linked to a requirement for more confinement in the individual ignitors. Once these systems did function, they exhibited comparable peak pressures and rise times to the M83 system. Tests 3 and 4 with LOVA propellant, thought to be more difficult to ignite, functioned considerably faster than tests 1 and 2 where M30 propellant was used. Test 3 (where the strongest confinement of the oxide ignitors was achieved) out-performed all other tests including the M83 system with respect to peak pressure, ignition delay and rise time.

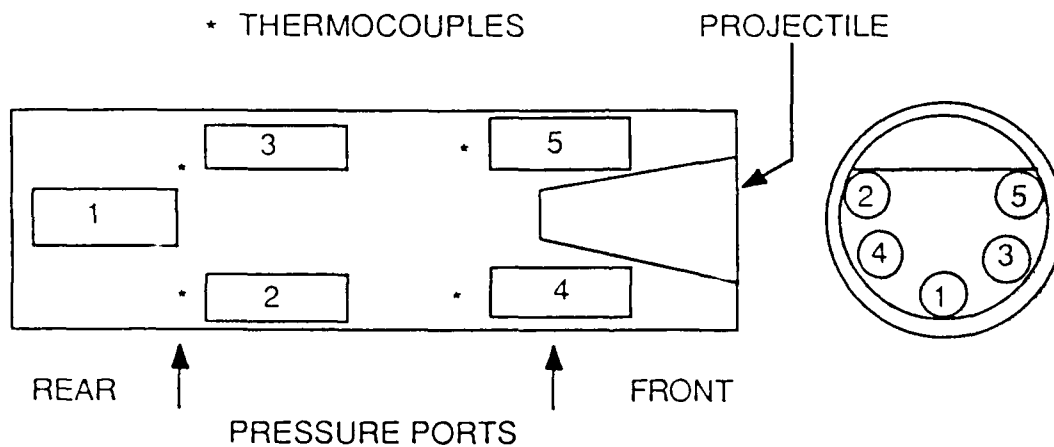

Figure 33. Simulator configuration ignitor placement live tests

Table 3. Live propellant simulator tests

Test	1	2	3	4	M83
Ignitor	Benite	Benite	Oxite	Oxite	Benite
Propellant	M30	M30	LOVA	LOVA	M30
Points Ignited	All	All	All	All	N/A
Peak Pressure	2.5KPSI	2.7KPSI	3.8KPSI	2.0KPSI	2.5KPSI
Time To Peak	130 ms	141 ms	17.6 ms	55 ms	24 ms
10-90% Time	2.7 ms	2.0 ms	0.8 ms	4.0 ms	2.0 ms

Summary of data:

- The laser-ignited multiple-point ignition system successfully ignited M30 and LOVA propellants in a simulator.
- All ignition points functioned with simultaneity of 5 ms.
- Delay times for Benite were longer than the standard center core ignitor.
- Delay times for Oxite were shorter than expected.
- Pressure rise and peak pressure values were consistent with the center core ignition system.

Standard operating procedure for Veritay ballistic simulator facility multiple-point laser actuated ignitor tests:

The facility should be locked during all phases of testing.

- Simulator data acquisition verification
- Check thermocouple and pressure sensor output by manual stimulation of each sensor-producing oscilloscope verification. Note the noise levels, channel settings, and the position in the simulator of each sensor.
- Replace the two thermocouple inputs to the oscilloscope with:

- Live propellant tests
- Check thermocouple and pressure sensor output by manual stimulation of each sensor with oscilloscope verification. Note the noise levels, channel settings, and position in the simulator of each sensor.
- Focus the high speed camera and set the aperture, speed and trigger delay. Note that the camera is loaded with unexposed film.
- Check the alignment of the laser to the fiberoptic patchcord. Check that the laser is out of standby, the shutter is closed and the laser is in the remote mode when alignment is complete. As a precautionary measure, place a blind at the laser output.
  - Turn up the energy level to the proper calibrated setting.
  - Remove the ignitor assembly from the conditioning oven (110F). Insert the ignitor assembly into the simulator. Note that all personnel involved with the simulator setup must wear both ankle and wrist grounding straps.
  - Fill the simulator with propellant and close up the simulator.
  - Couple the fiberoptic patchcord to the breech laser input.
- Remove the blind at the laser output.
- Initiate the following firing sequence:
  - Set the scope into HOLD NEXT mode. Check that the scope settings are correct.
  - Disengage the safety interlock.
  - Switch the laser into STANDBY.
  - Open the shutter.
  - Fire.

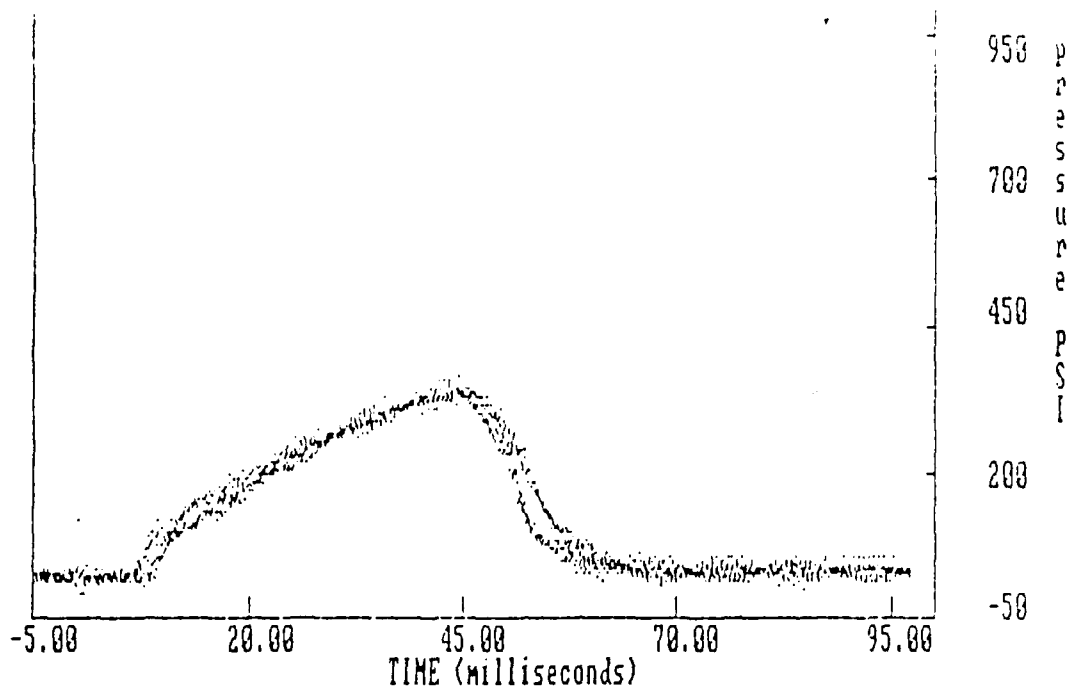

Figure 34. Inert test, configuration 1 both pressure transducers

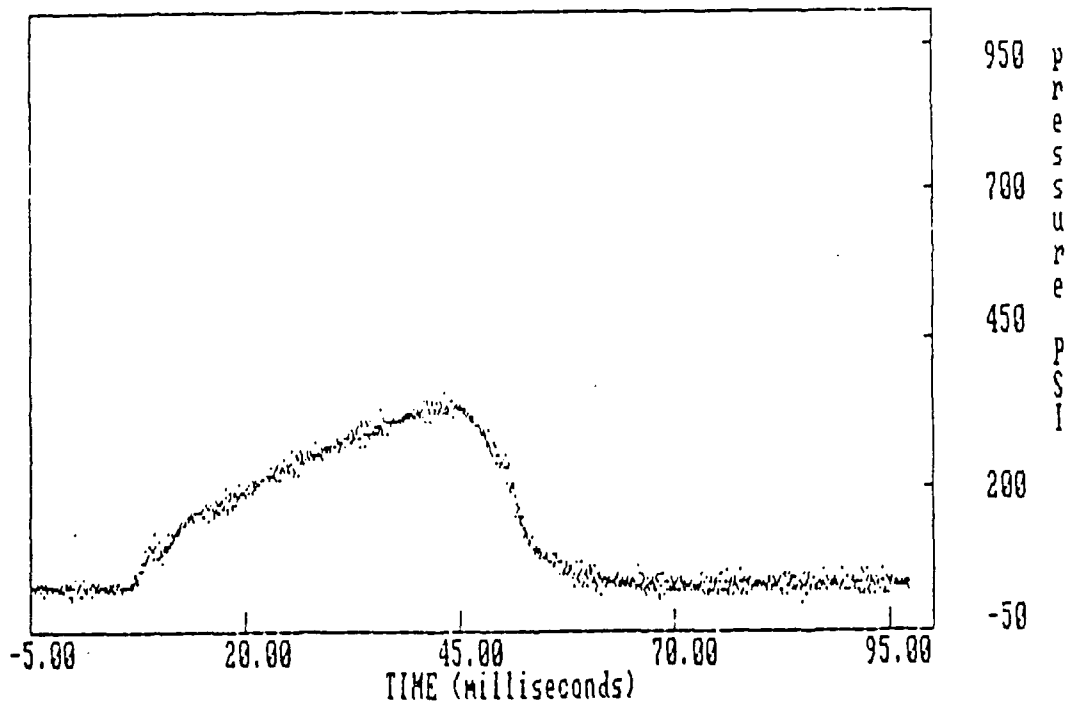

Figure 35. Inert test, configuration 1 front pressure transducer

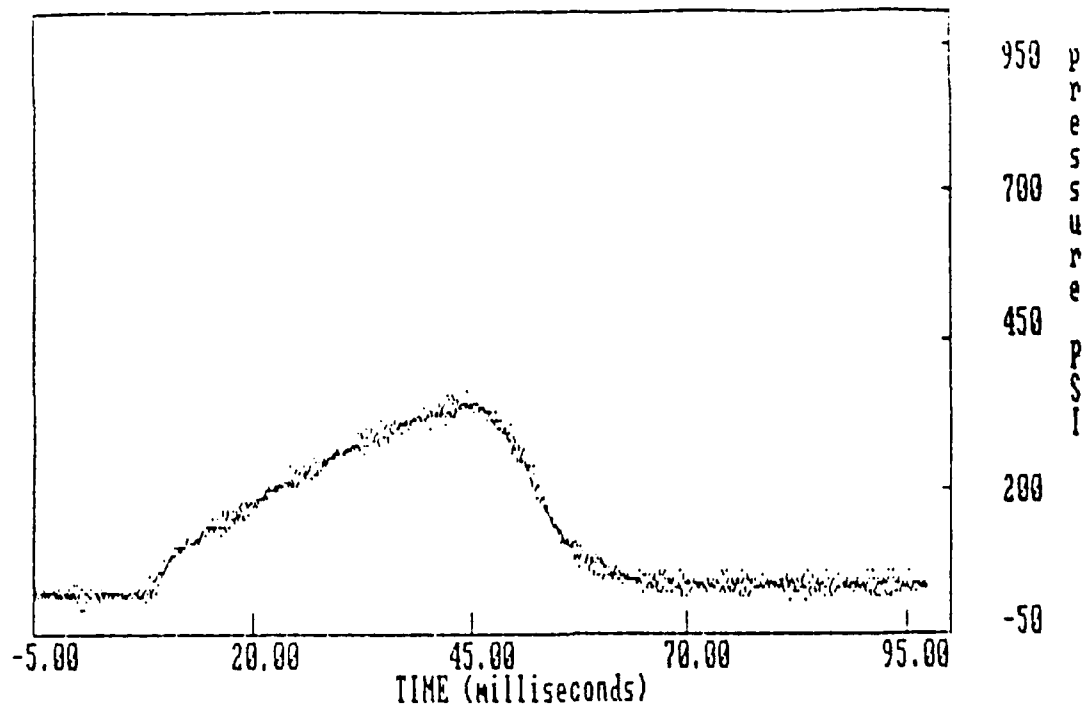

Figure 36. Inert test, configuration 1 rear pressure transducer

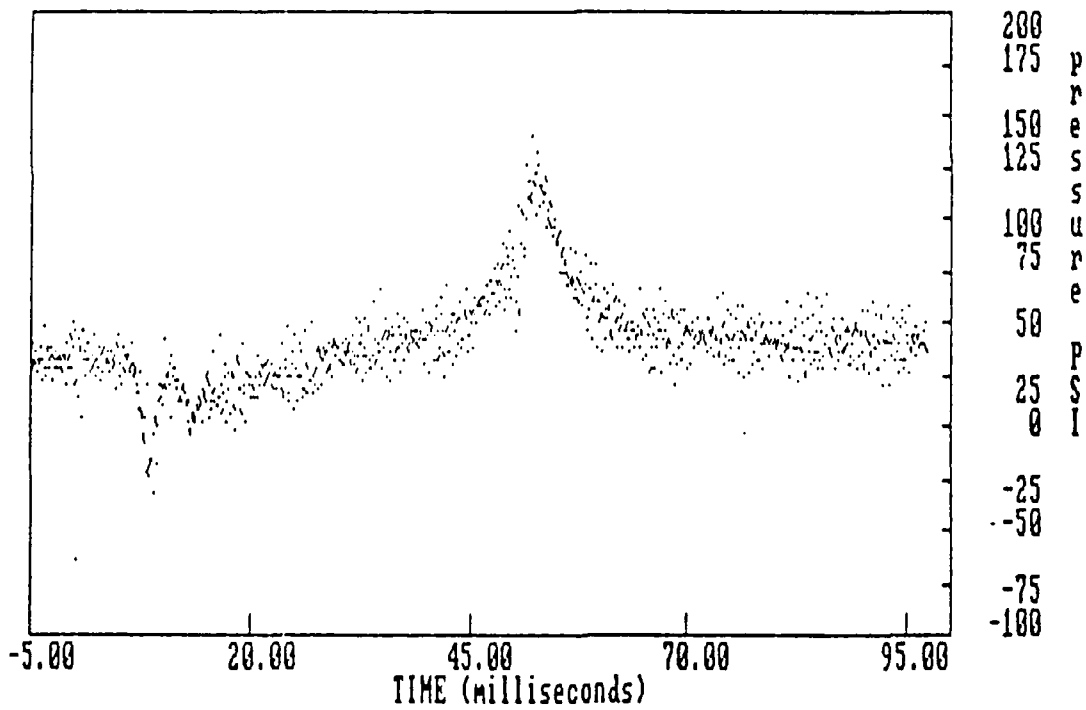

Figure 37. Inert test, configuration 1 pressure differential (rear-front)

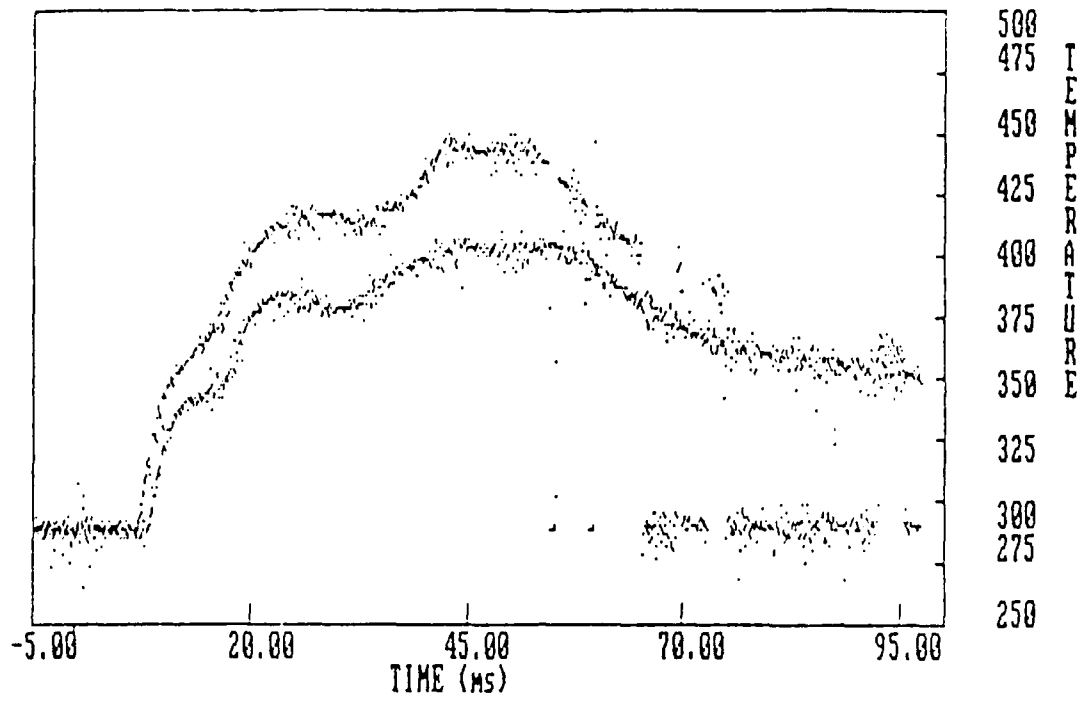

Figure 38. Inert test, configuration 1 both thermocouples

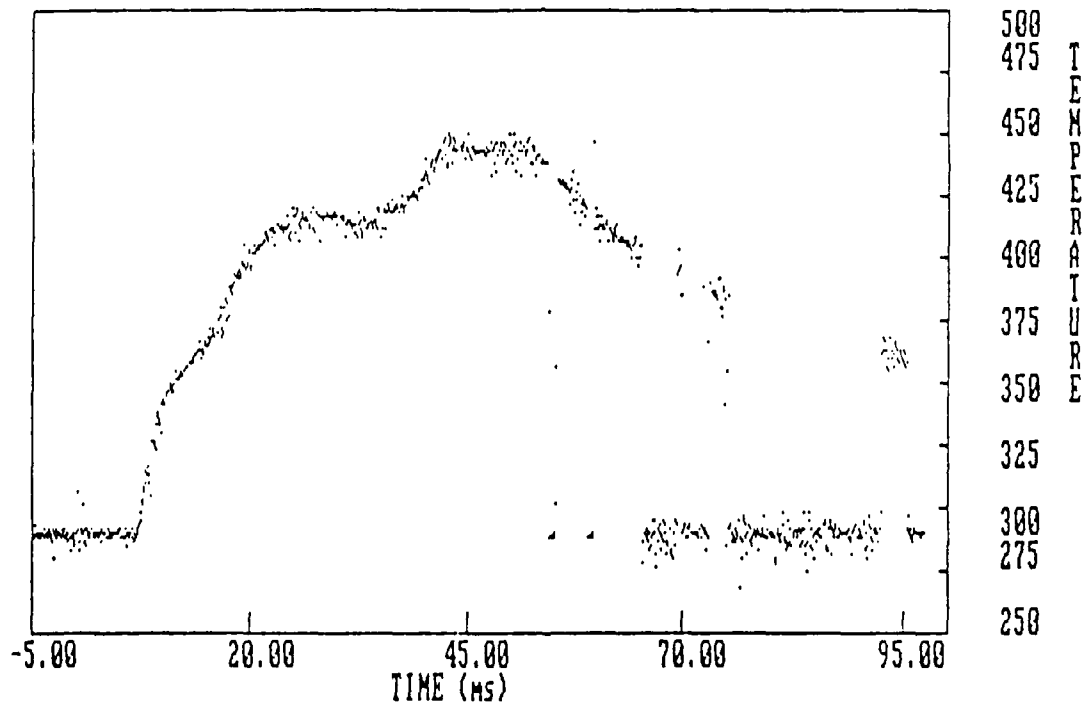

Figure 39. Inert test, configuration 1 front thermocouples

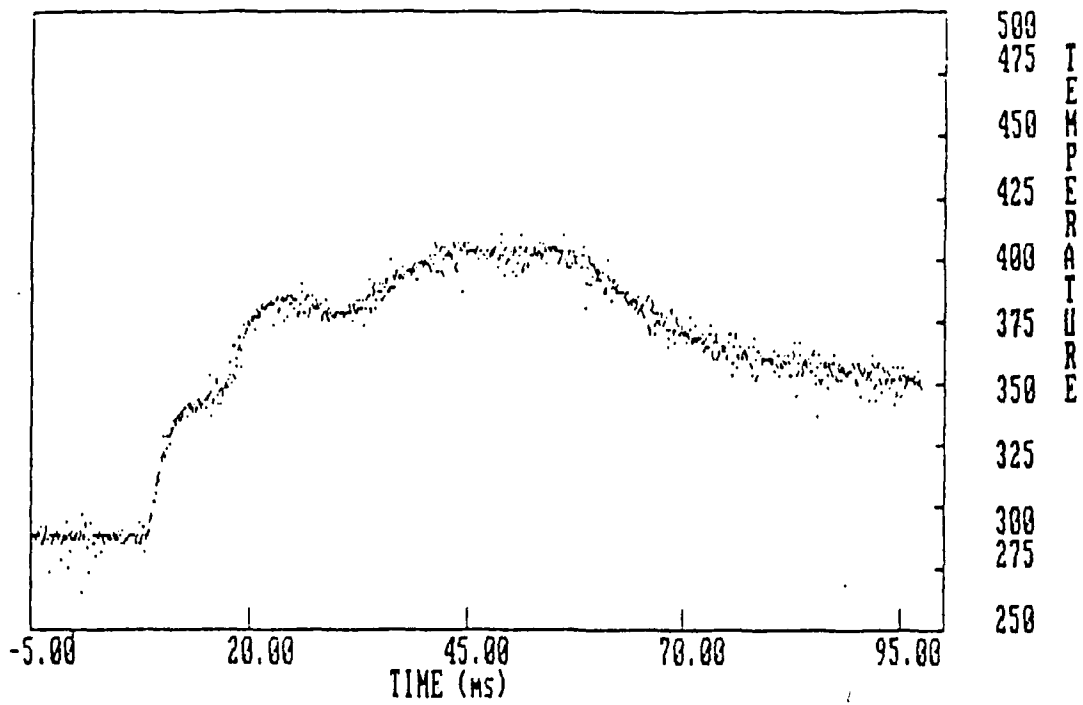

Figure 40. Inert test, configuration 1 rear thermocouple

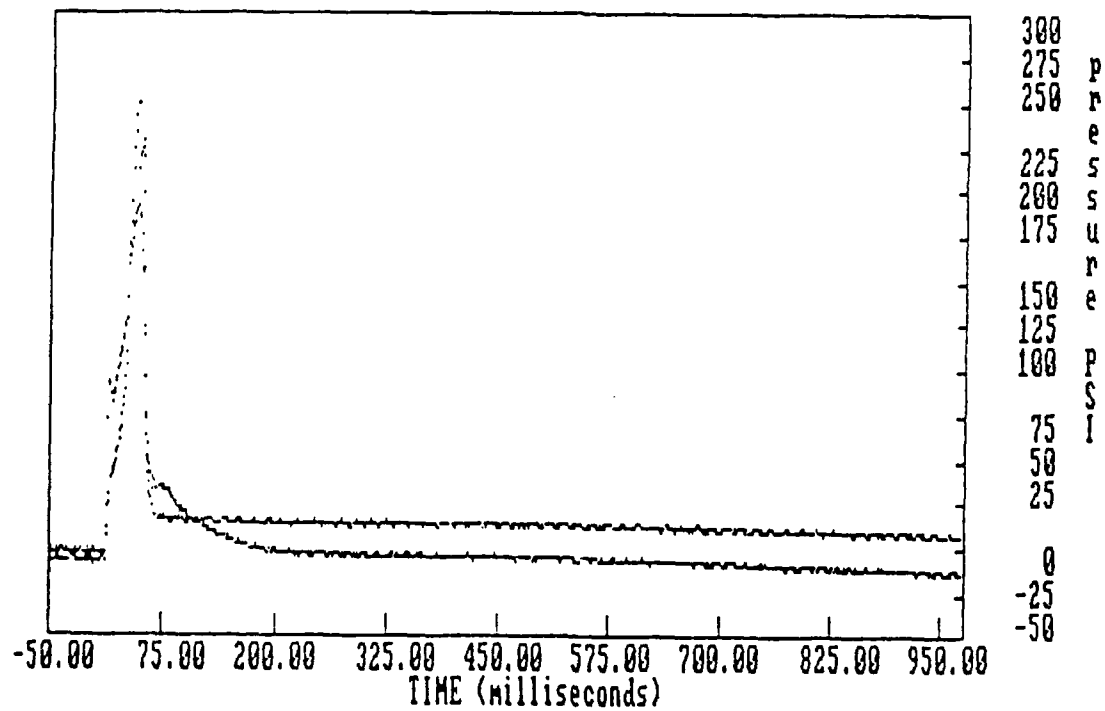

Figure 41. Inert test, configuration 3 both pressure transducer

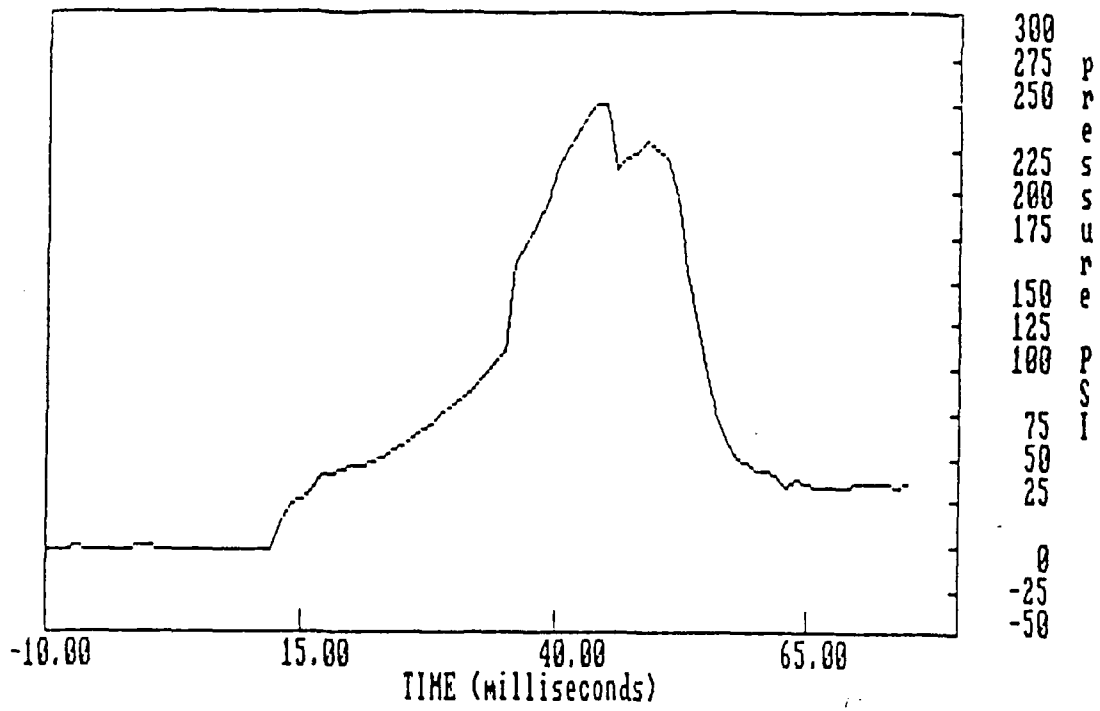

Figure 42. Inert test, configuration 3 front pressure transducer

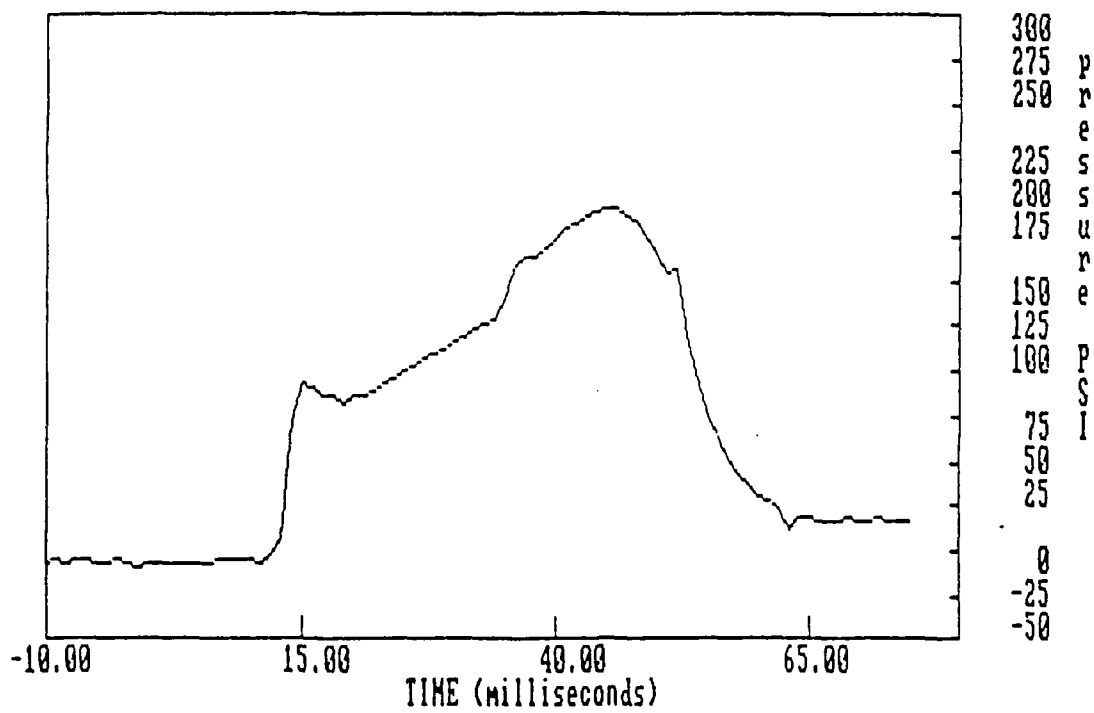

Figure 43. Inert test, configuration 3 rear pressure transducer

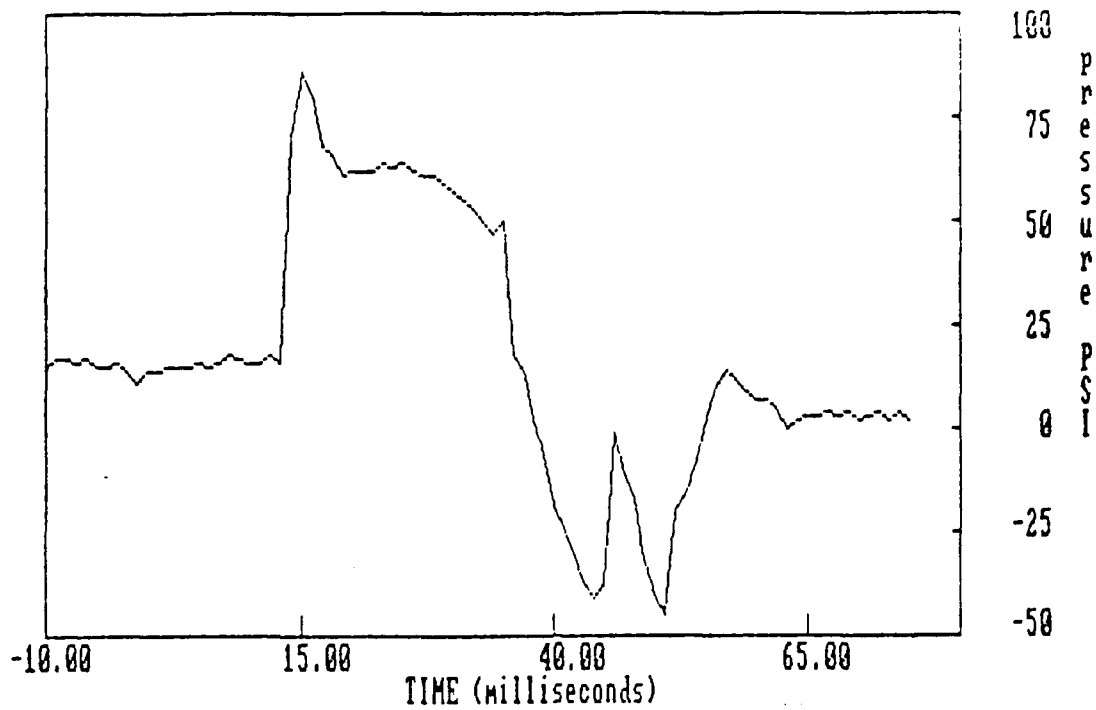

Figure 44. Inert test, configuration 3 pressure differential (rear-front)

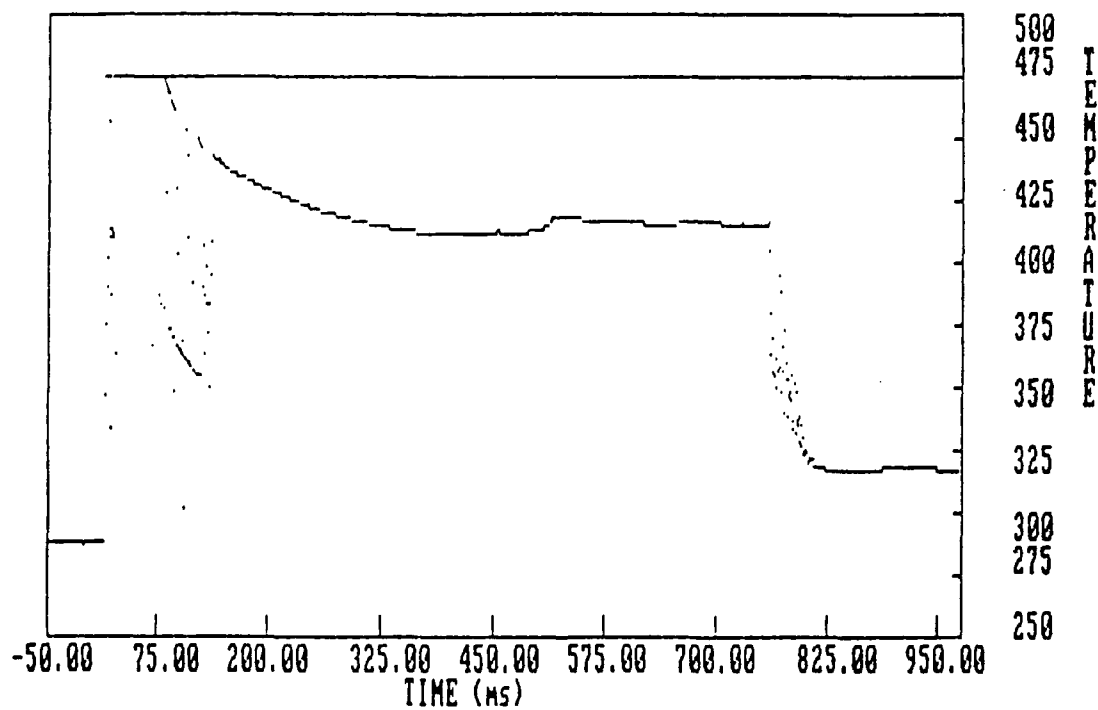

Figure 45. Inert test, configuration 3 both thermocouples

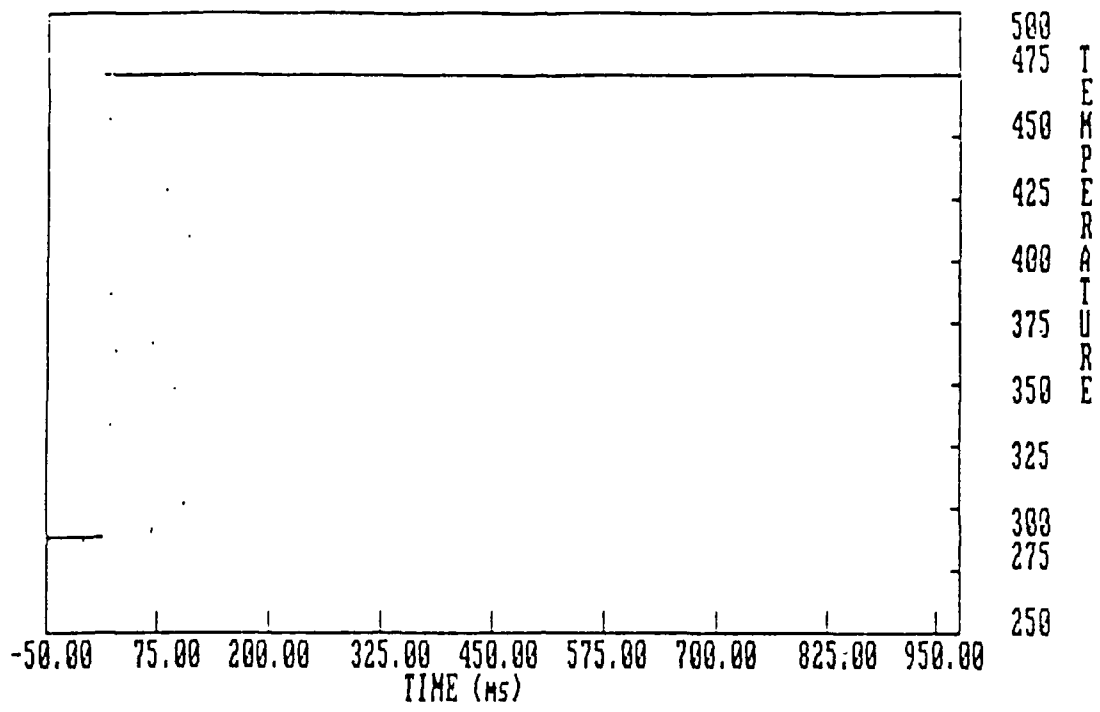

Figure 46. Inert test, configuration 3 front thermocouple

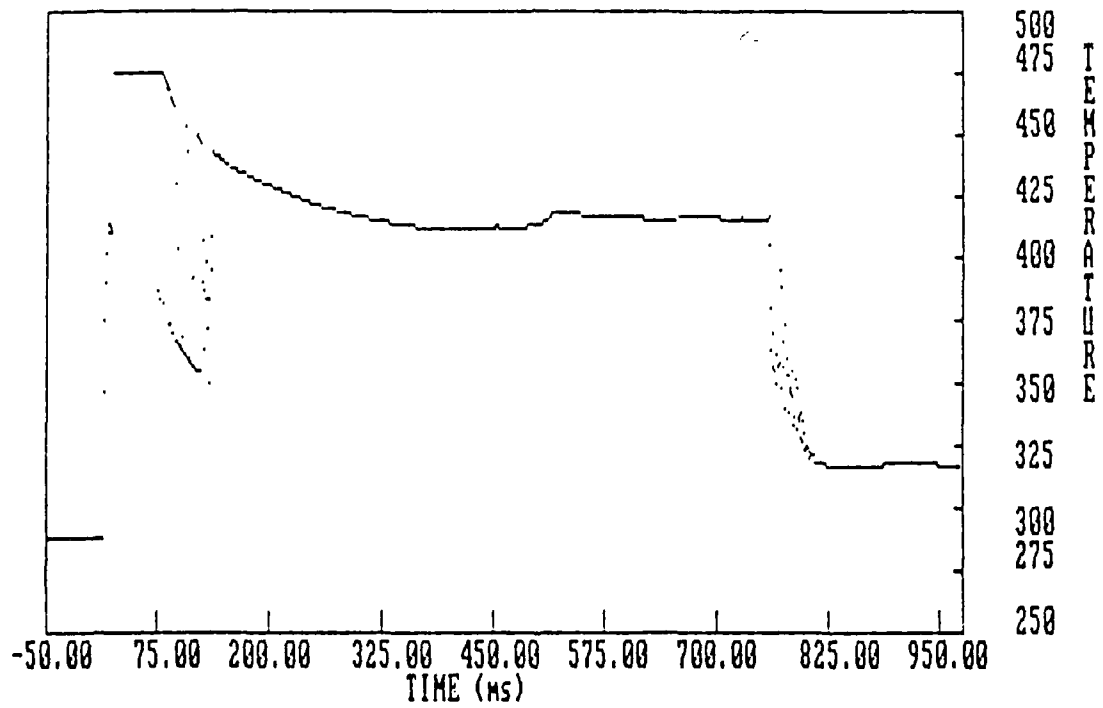

Figure 47. Inert test, configuration 3 rear thermocouple

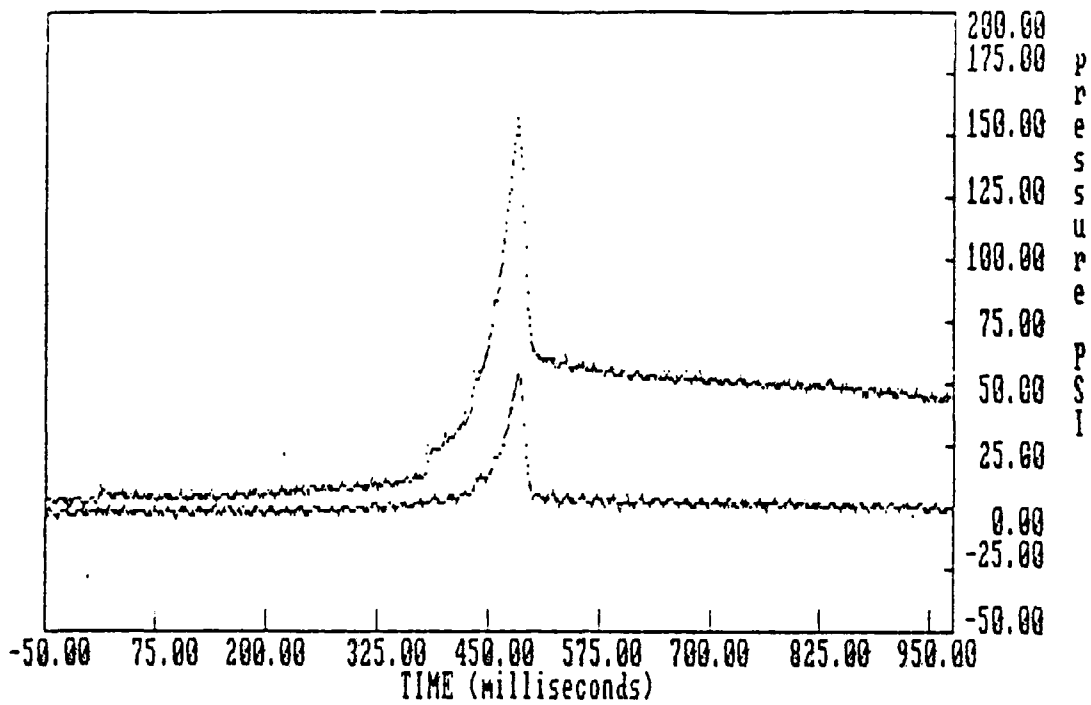

Figure 48. - Inert test, configuration 4 both pressure transducers

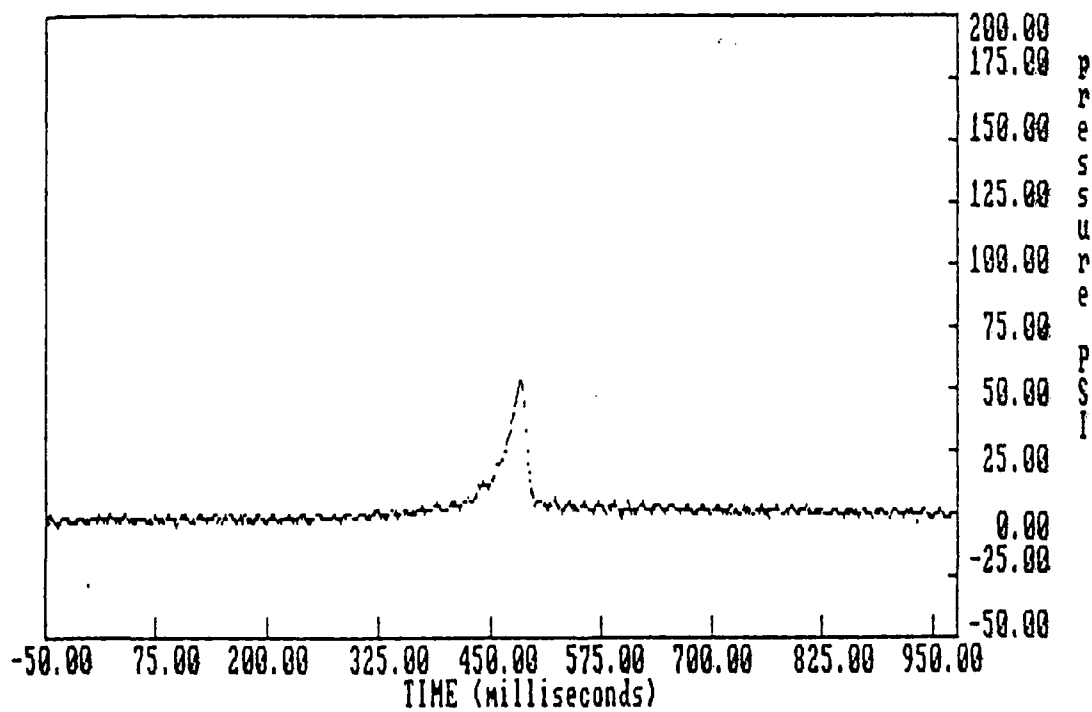

Figure 49. Inert test, configuration 4 front pressure transducers

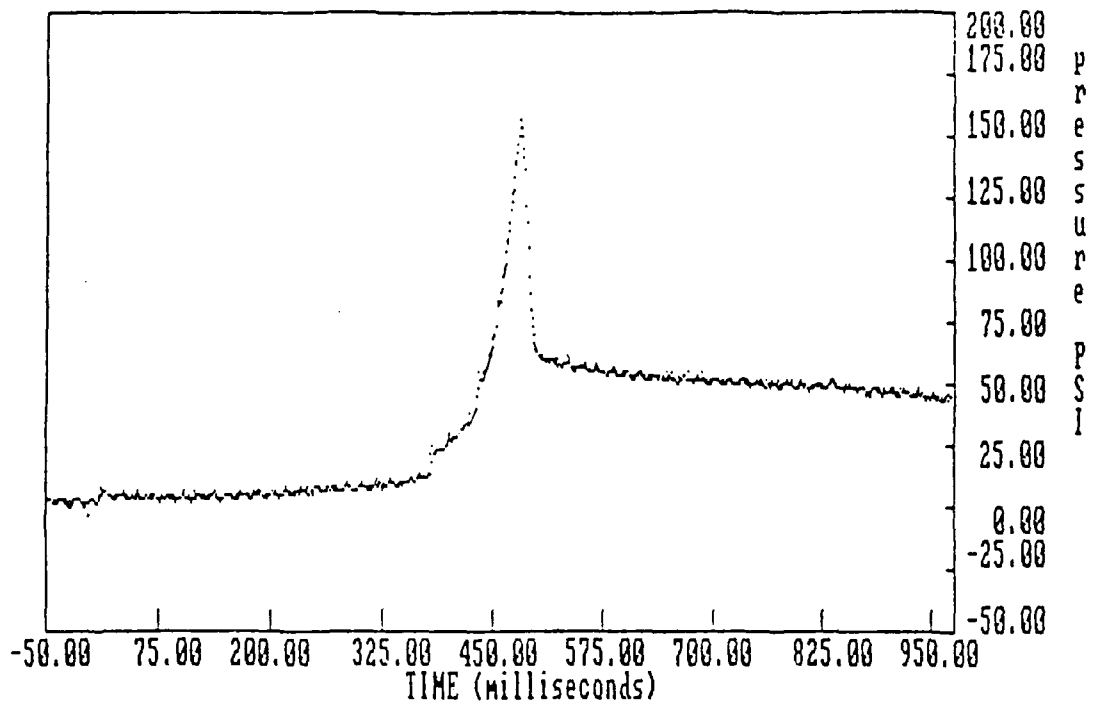

Figure 50. Inert test, configuration 4 rear pressure transducer

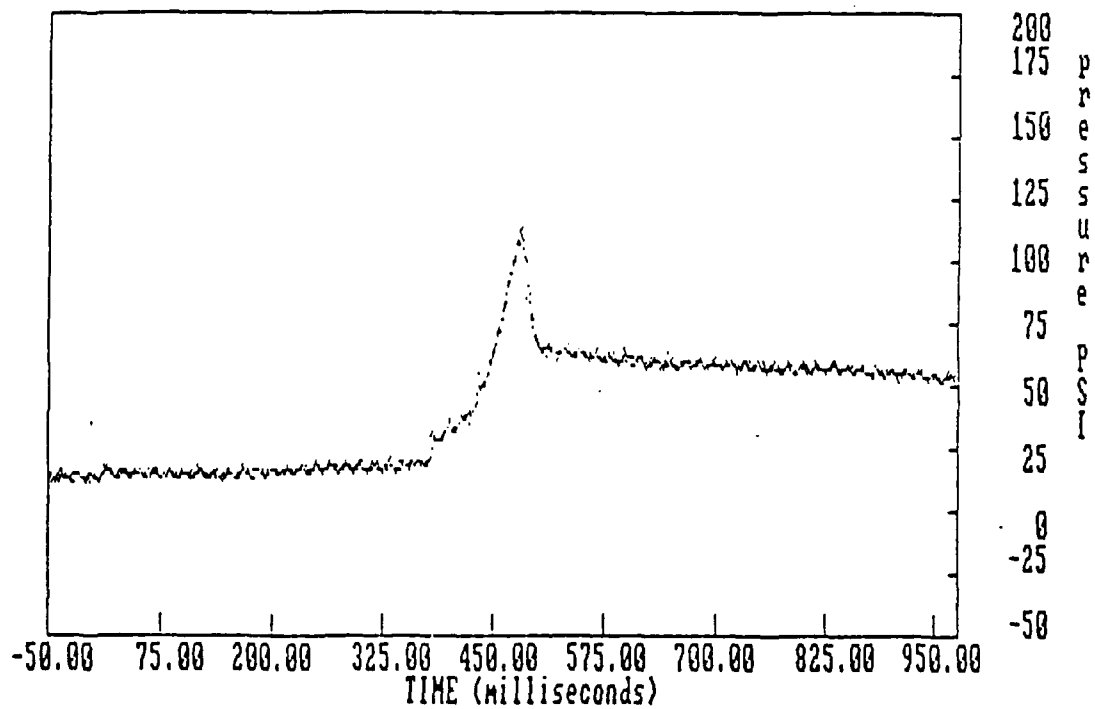

Figure 51. Inert test, configuration 4 pressure differential

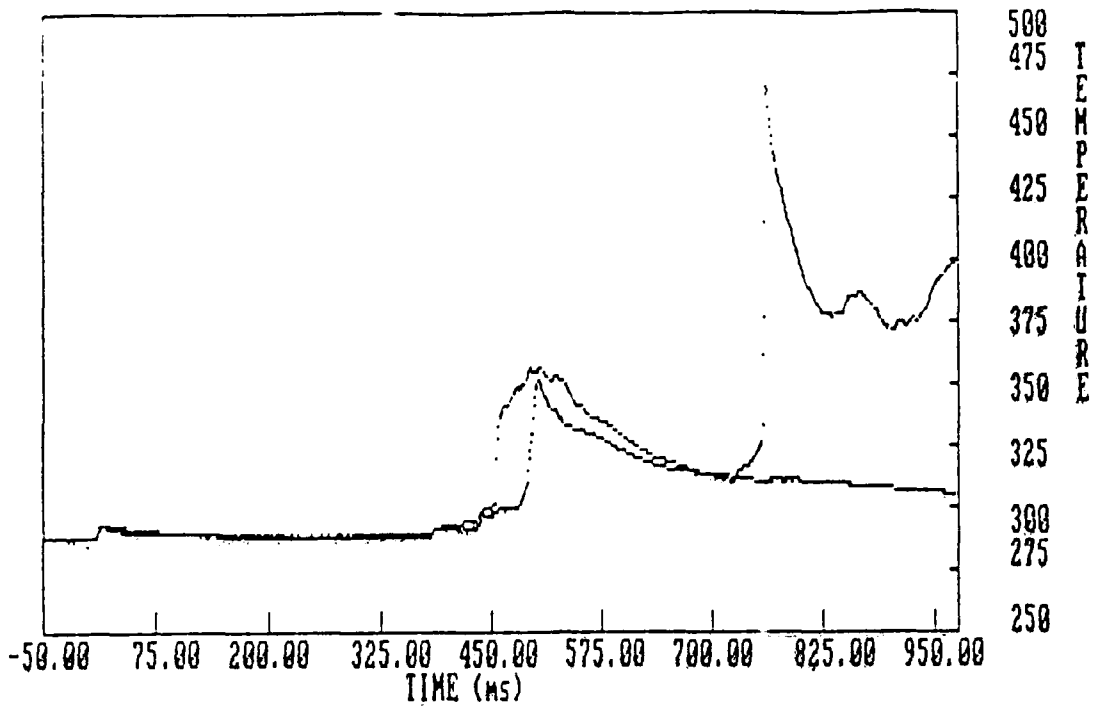

Figure 52. Inert test, configuration 4 both thermocouples

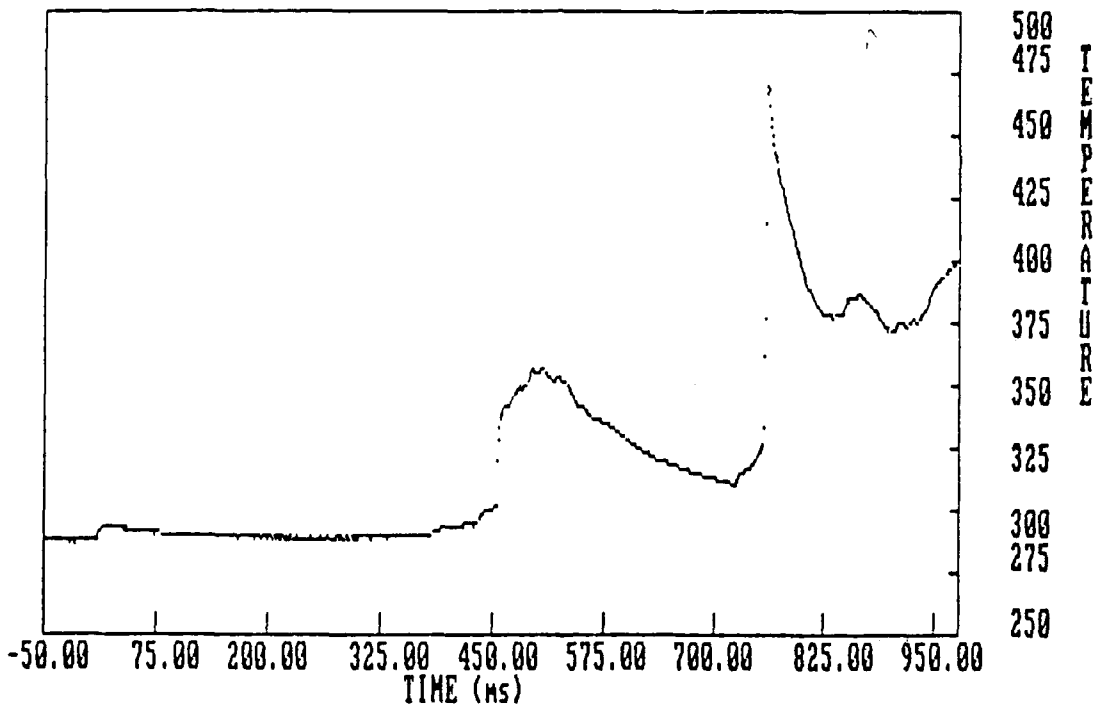

Figure 53. Inert test, configuration 4 front thermocouple

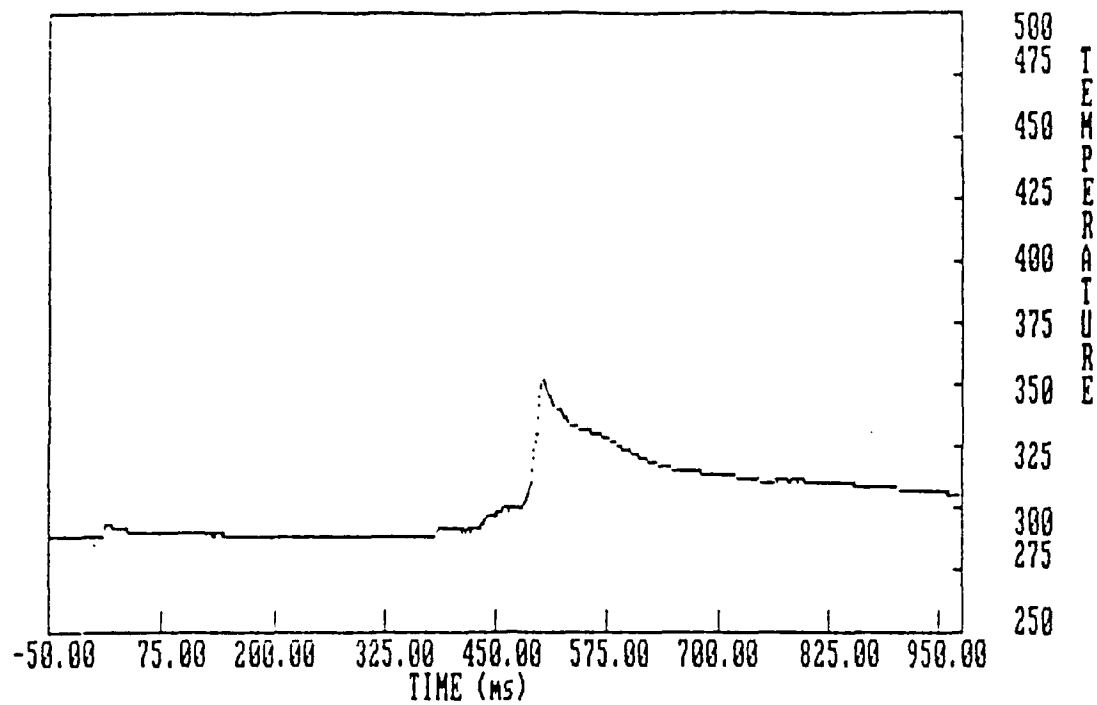

Figure 54. Inert test, configuration 4 rear thermocouple

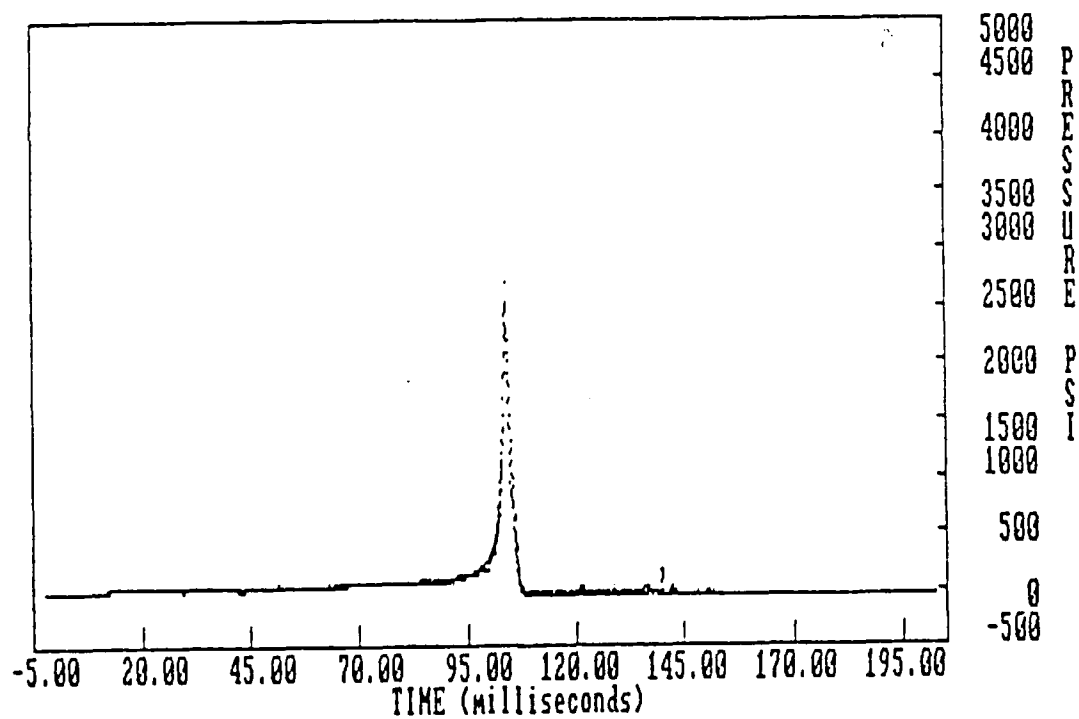

Figure 55. Live test, configuration 1 both pressure transducers

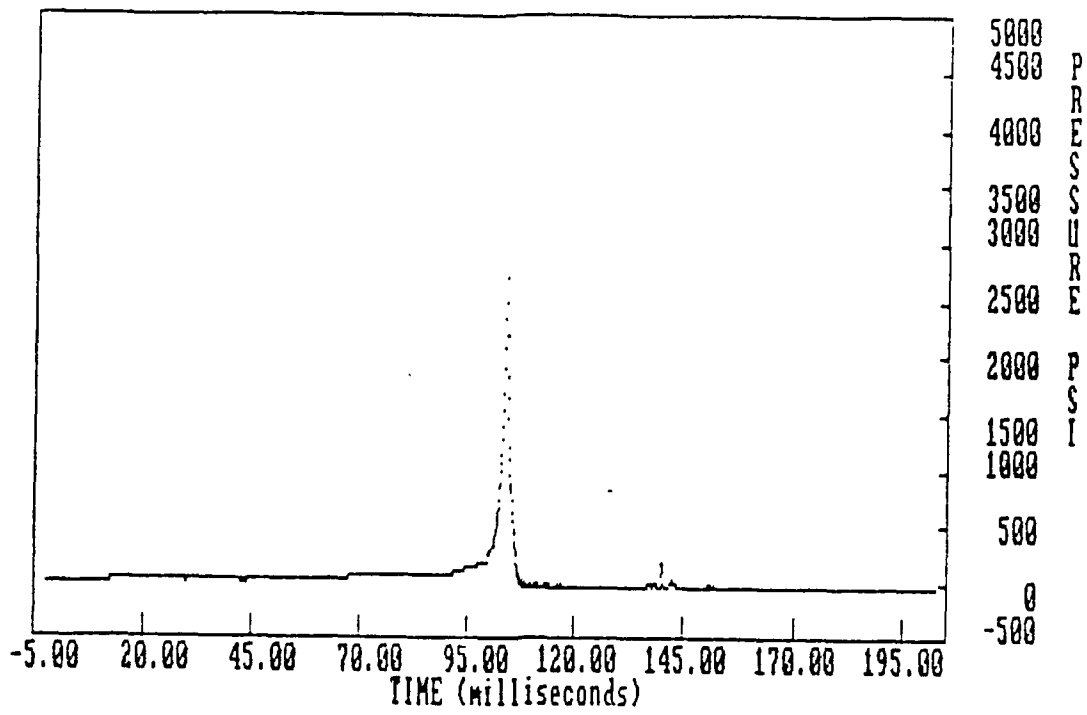

Figure 56. Live test, configuration 1 front pressure transducer

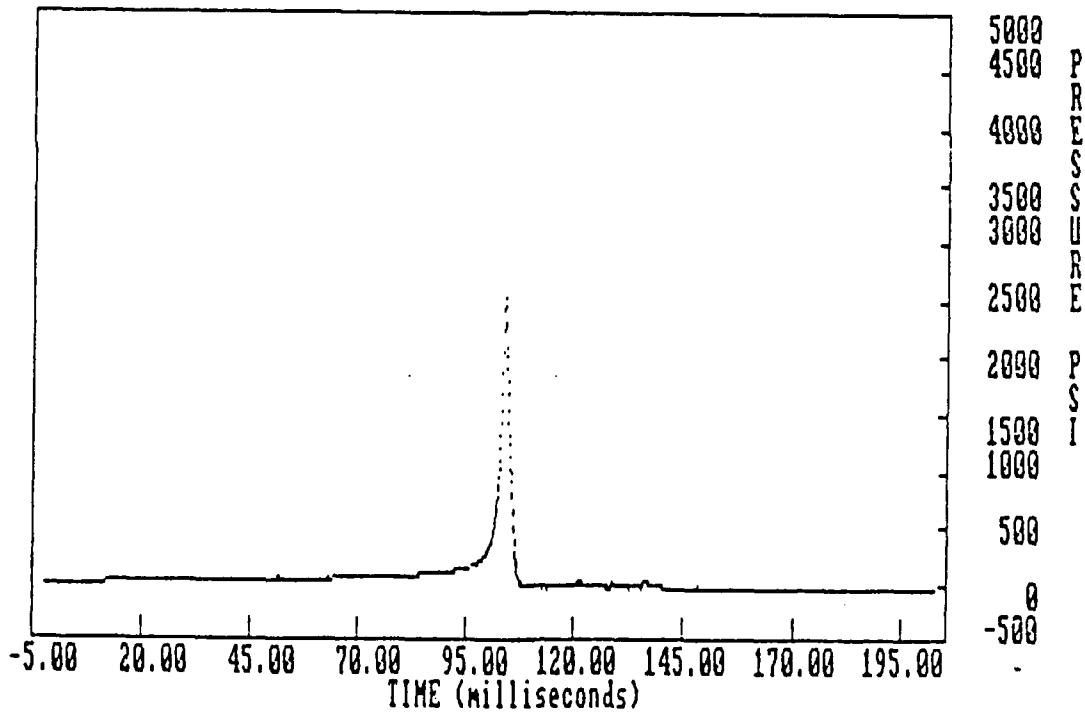

Figure 57. Live test, configuration 1 rear pressure transducer

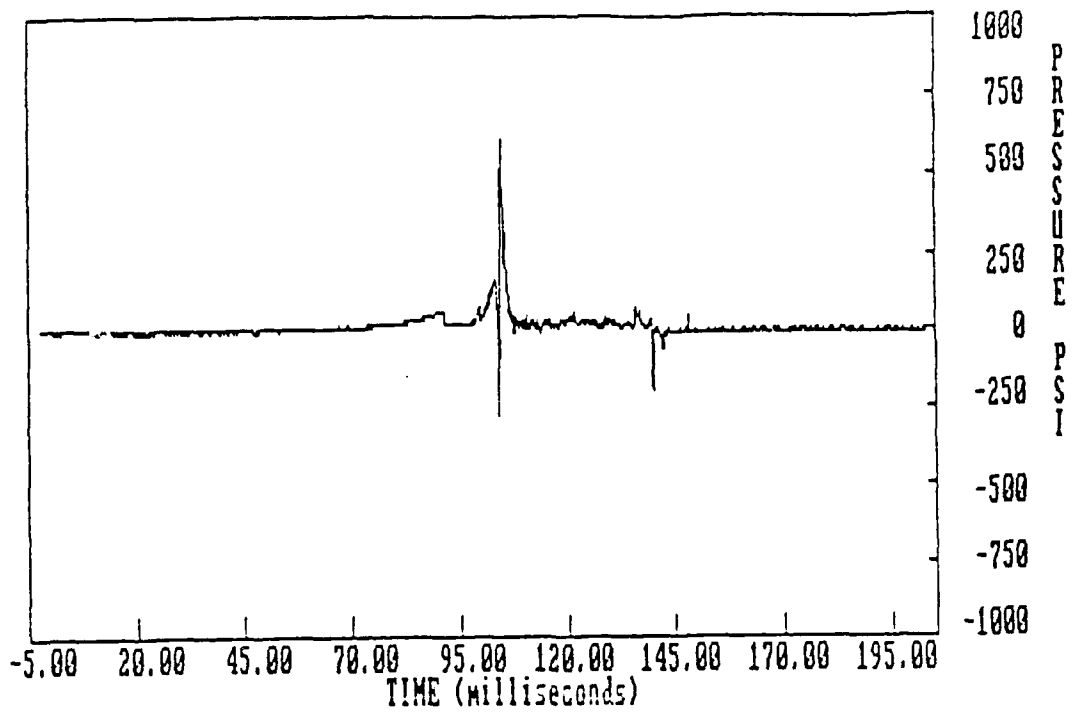

Figure 58. Live test, configuration 1 pressure difference (rear-front)

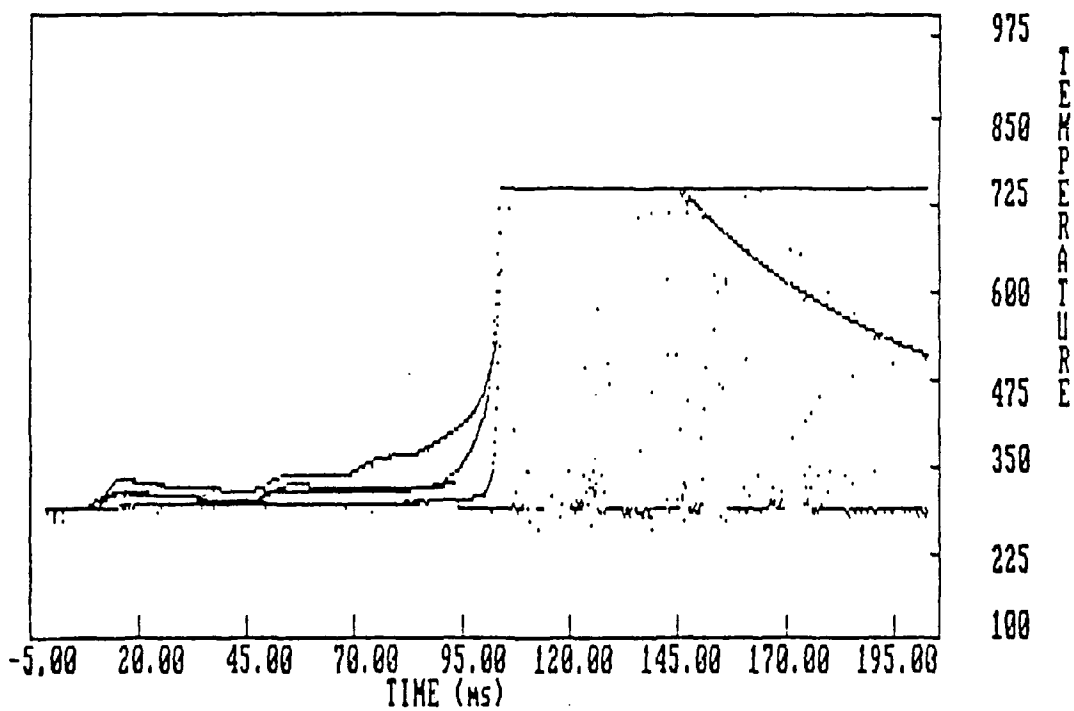

Figure 59. Live test, configuration 1 all four thermocouples

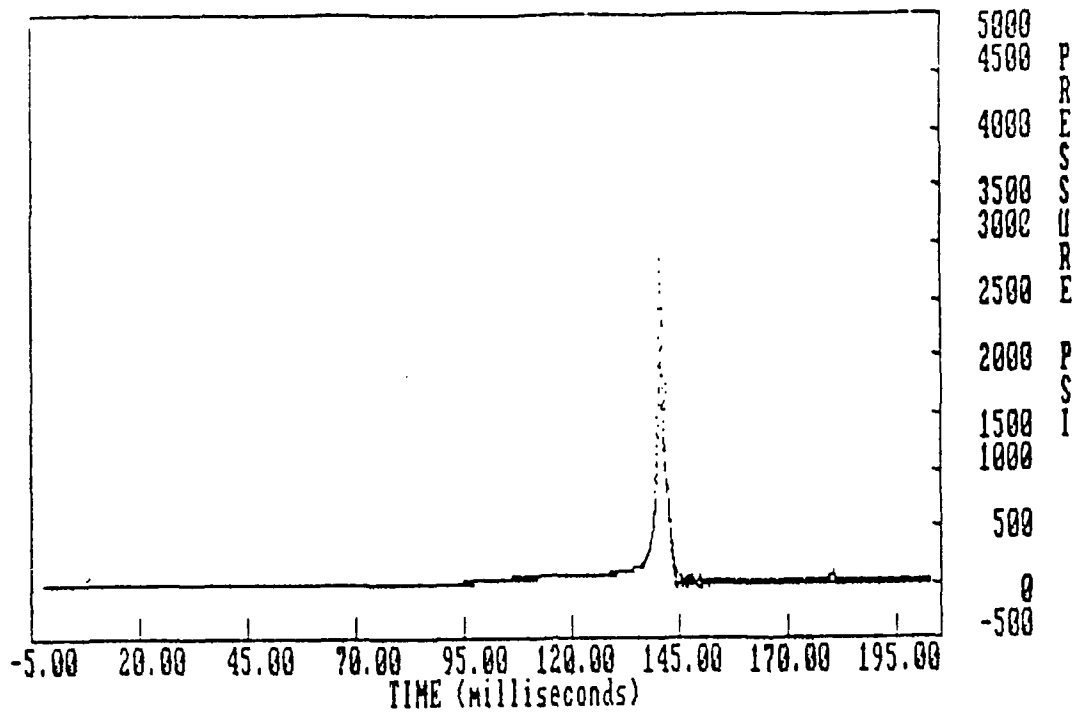

Figure 60. Live test, configuration 2 both pressure transducers

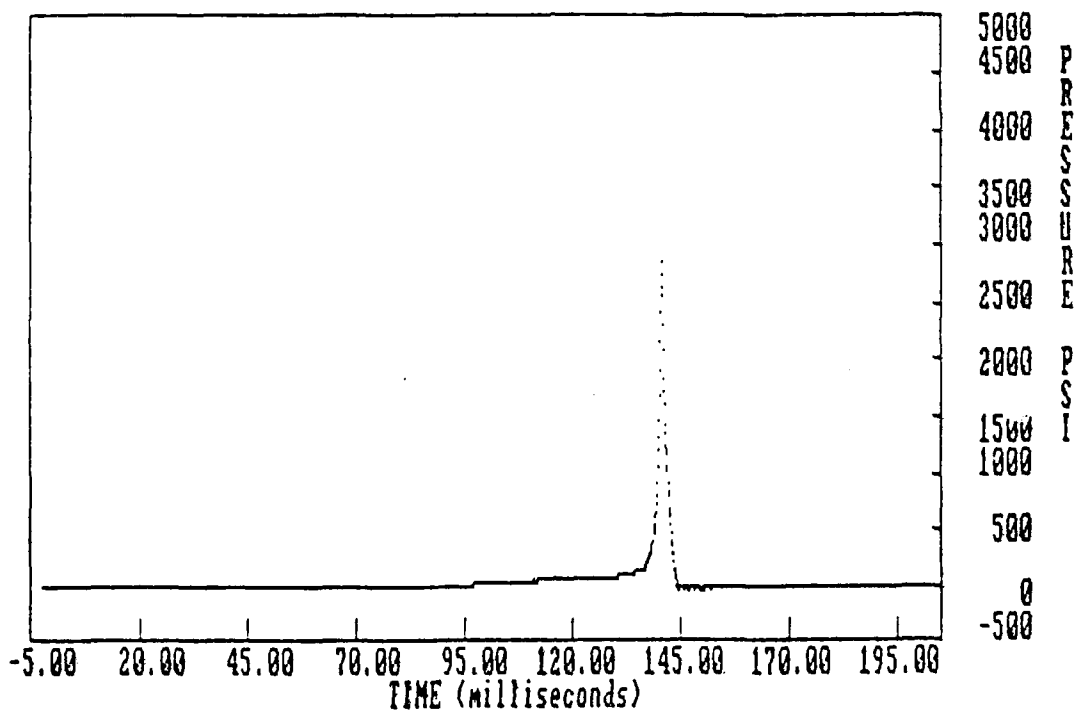

Figure 61. Live test, configuration 2 front pressure transducer

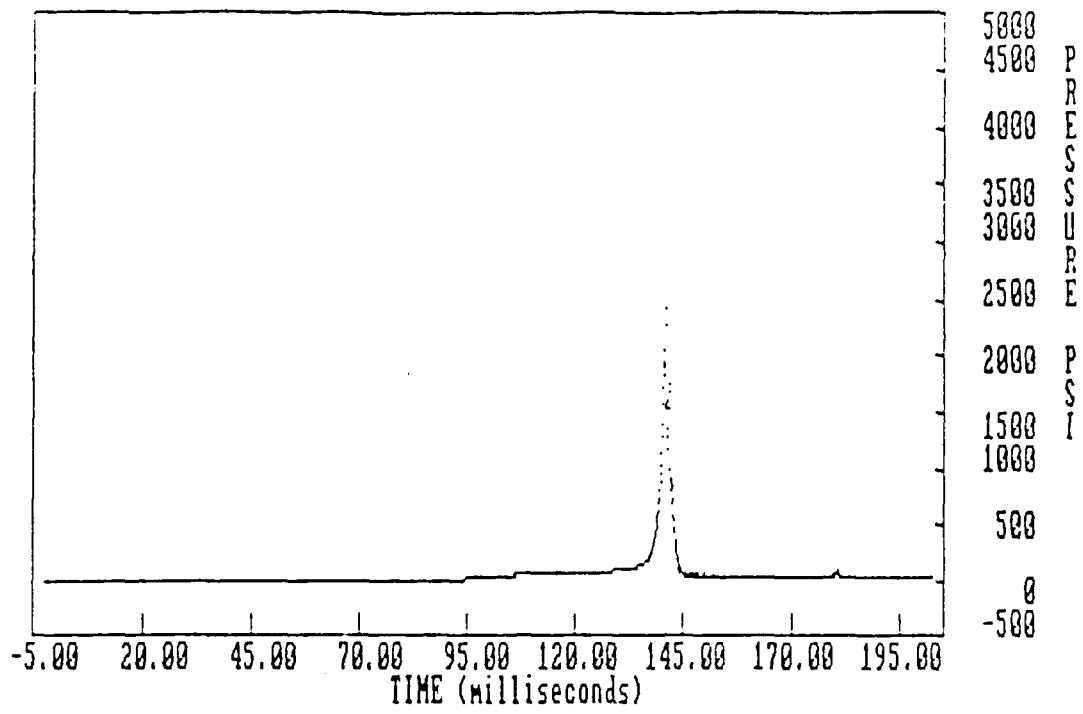

Figure 62. Live test, configuration 2 rear pressure transducer

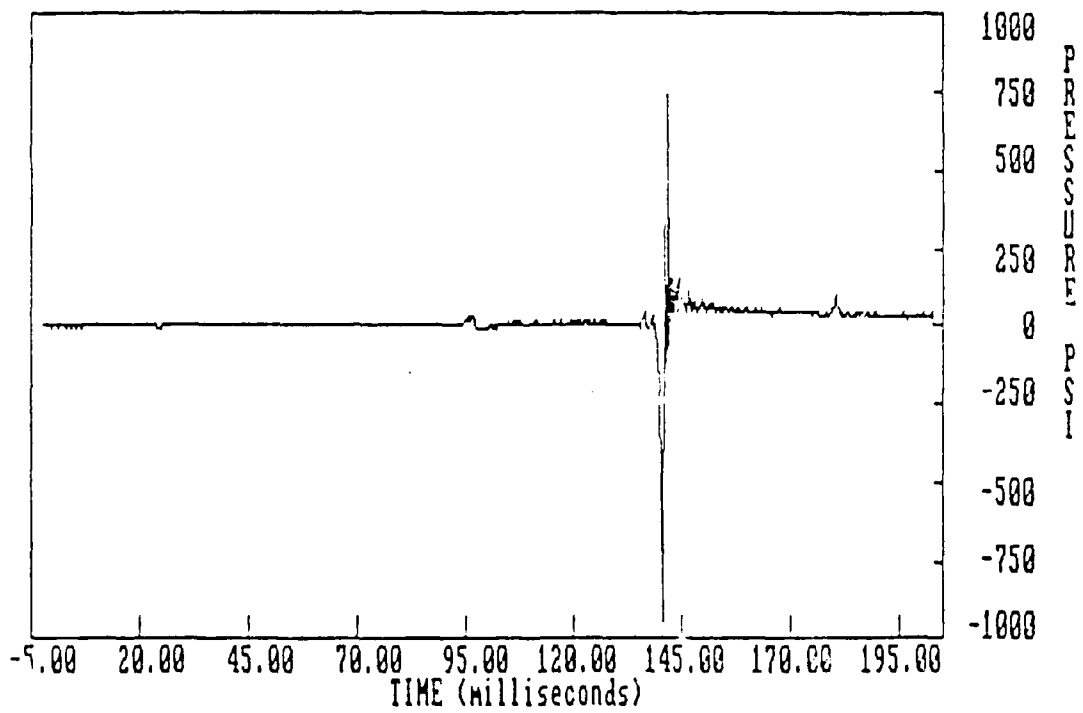

Figure 63. Live test, configuration 2 pressure difference (rear-front)

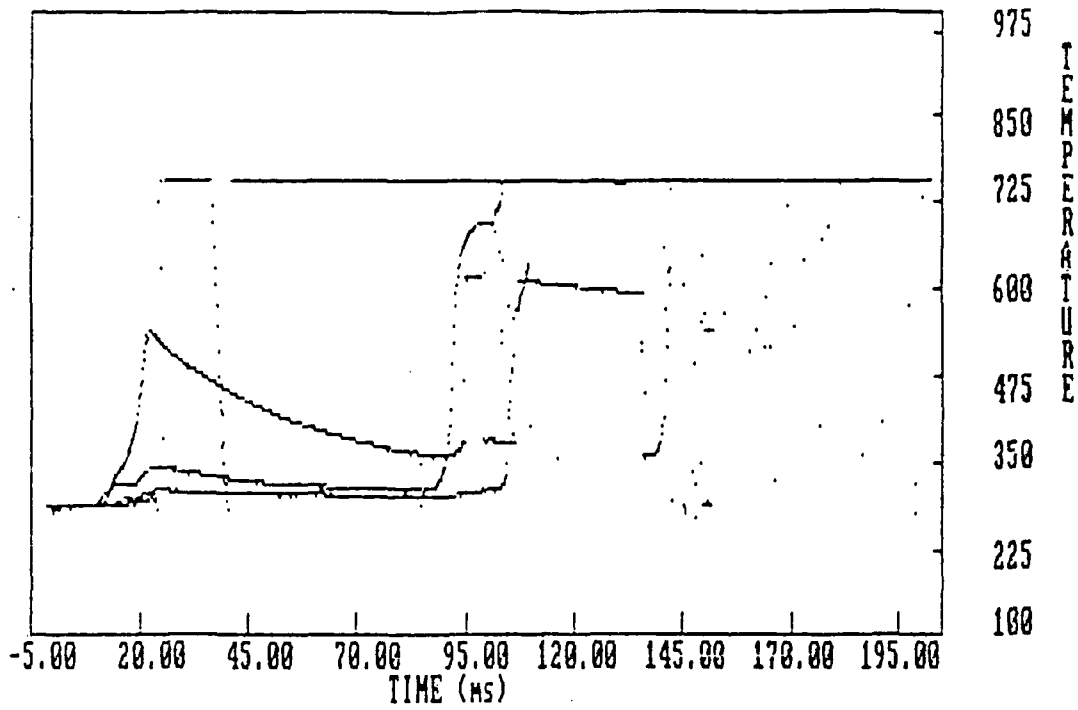

Figure 64. Live test, configuration 2 all four thermocouples

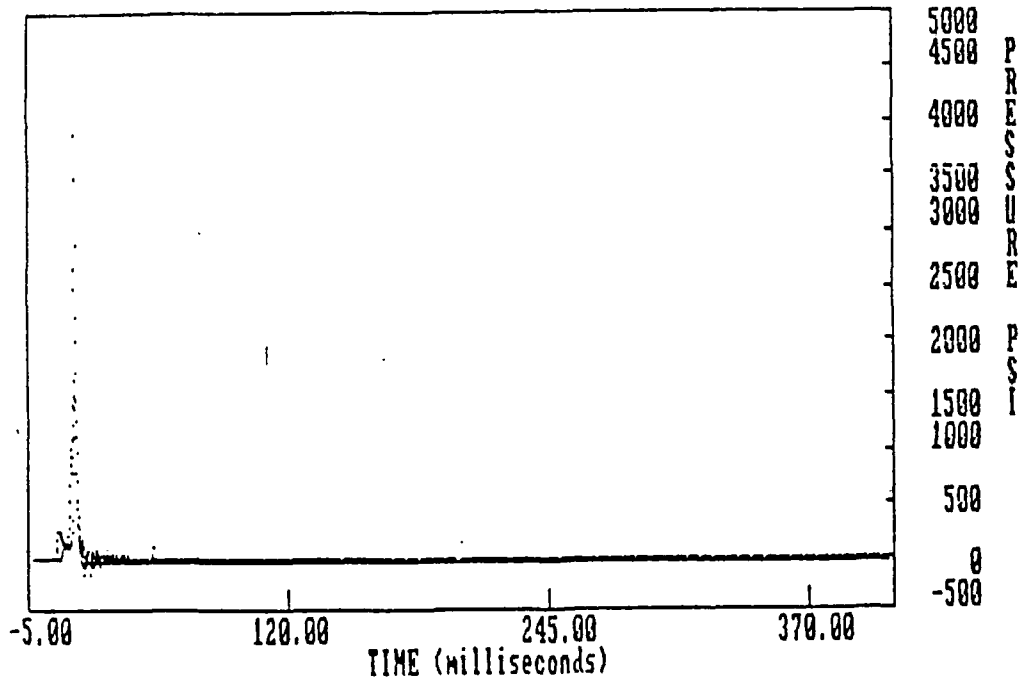

Figure 65. Live test, configuration 3 both pressure transducers

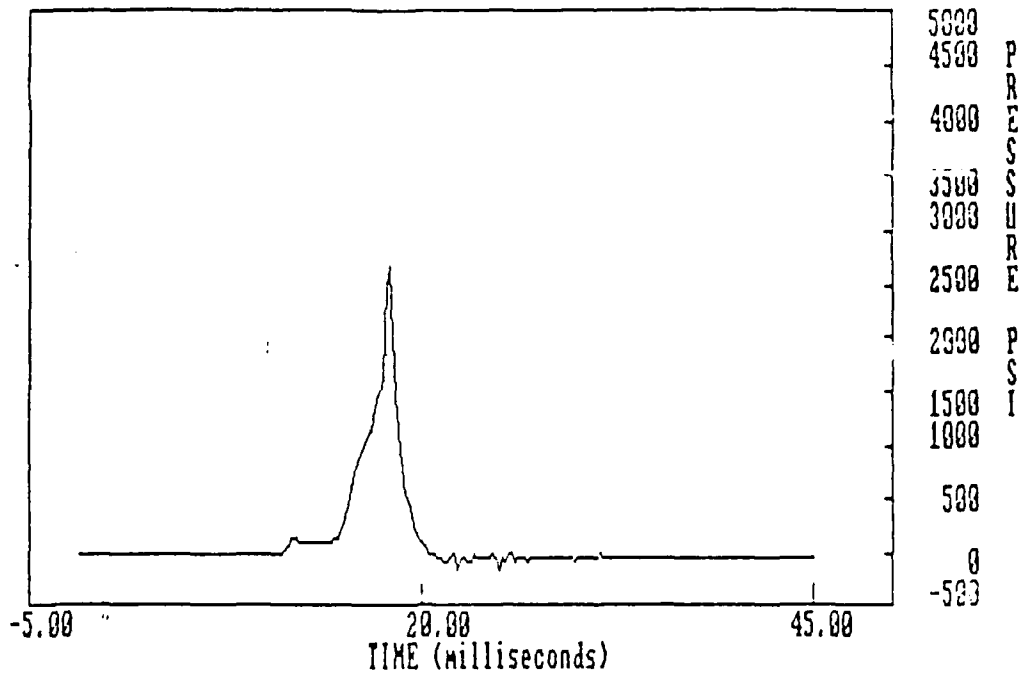

Figure 66. Live test, configuration 3 front pressure transducer

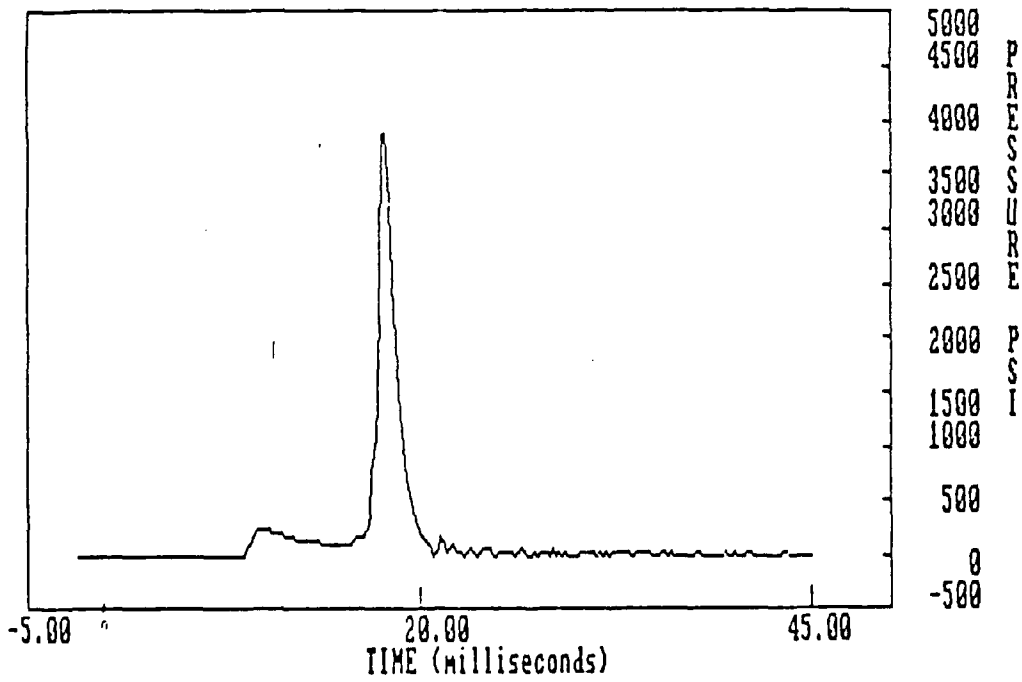

Figure 67. Live test, configuration 3 rear pressure transducer

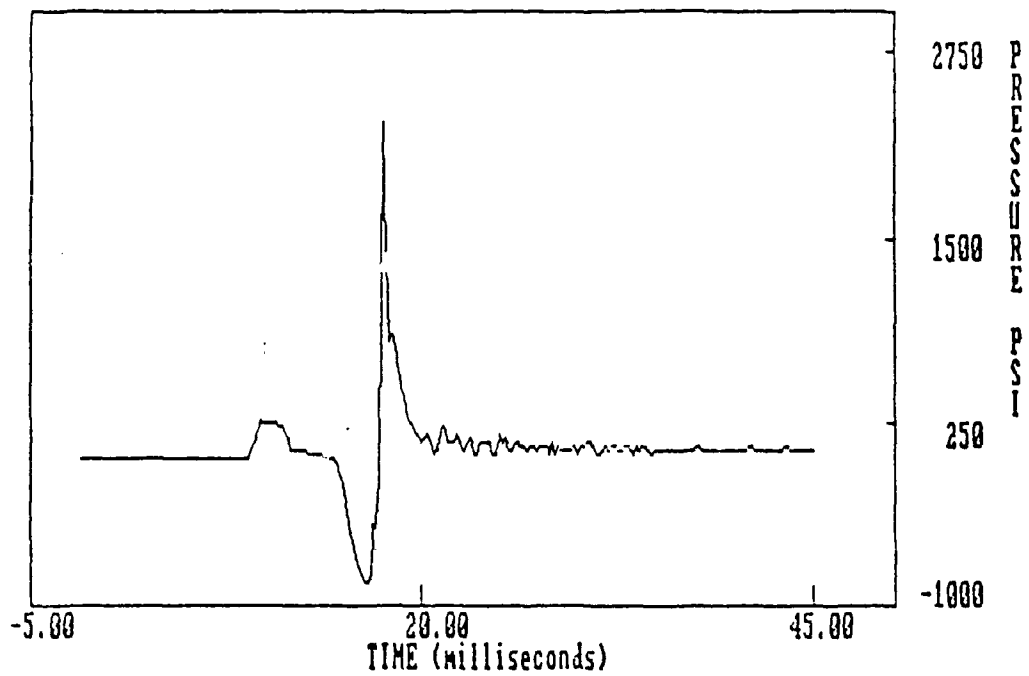

Figure 68. Live test, configuration 3 pressure difference (rear-front)

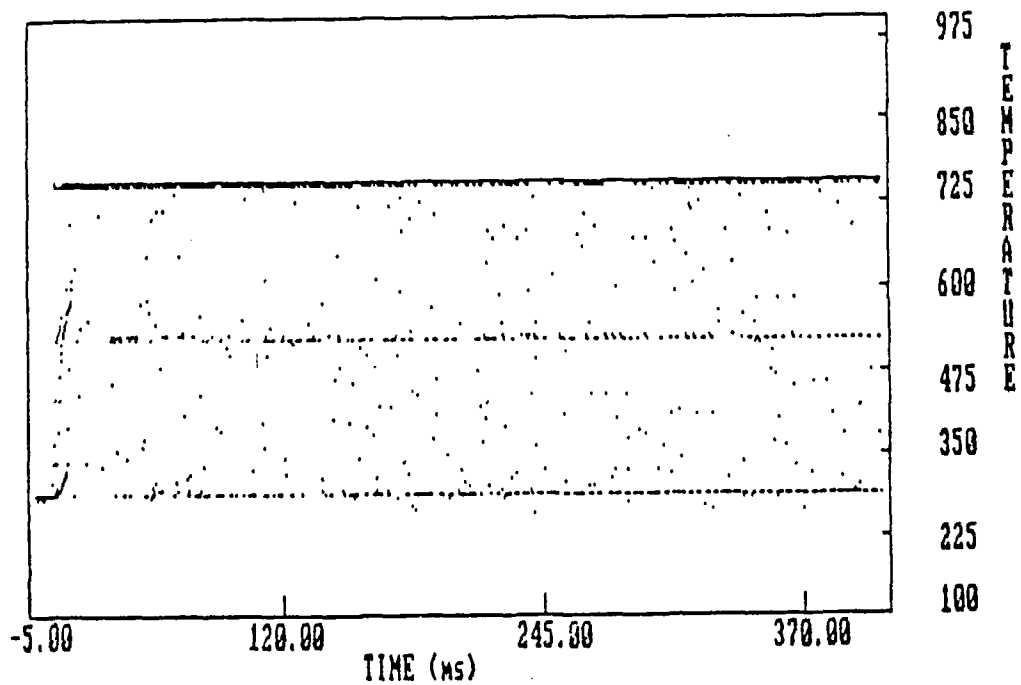

Figure 69. Live test, configuration 3 all four thermocouples

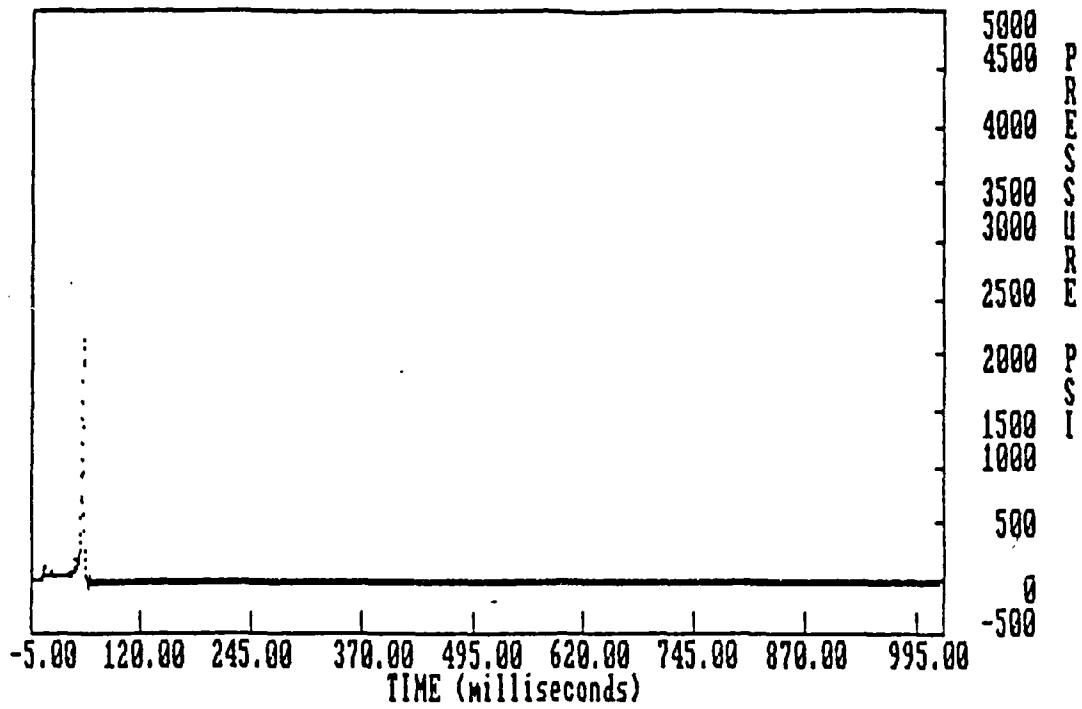

Figure 70. Live test, configuration 4 both pressure transducers

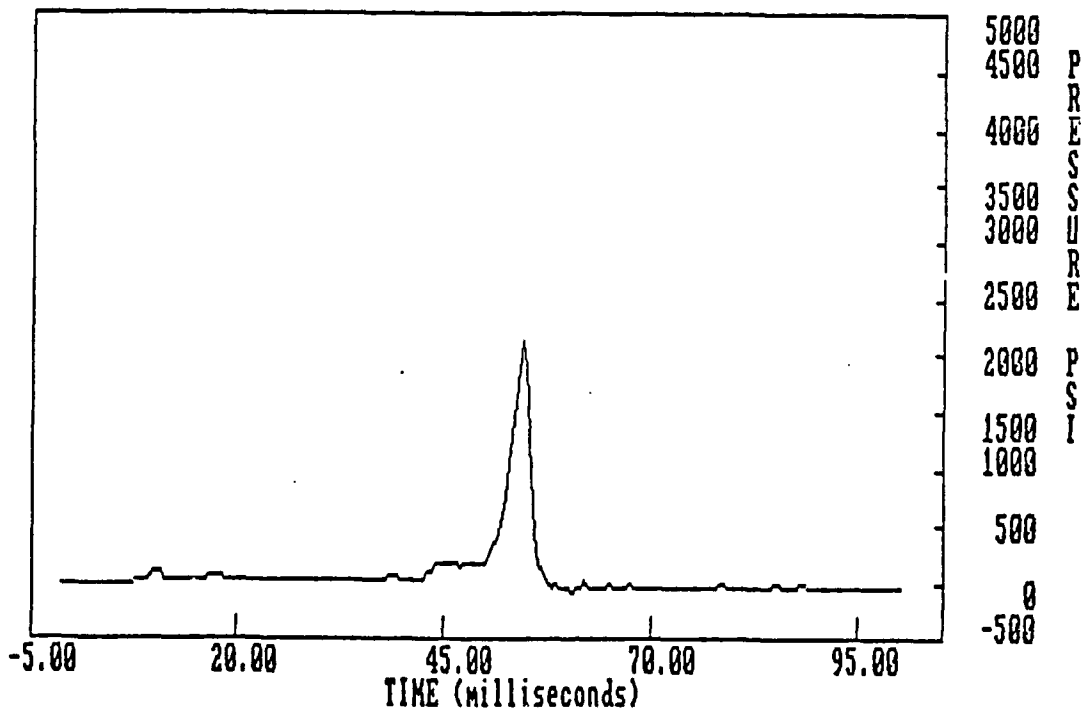

Figure 71. Live test, configuration 4 front pressure transducer

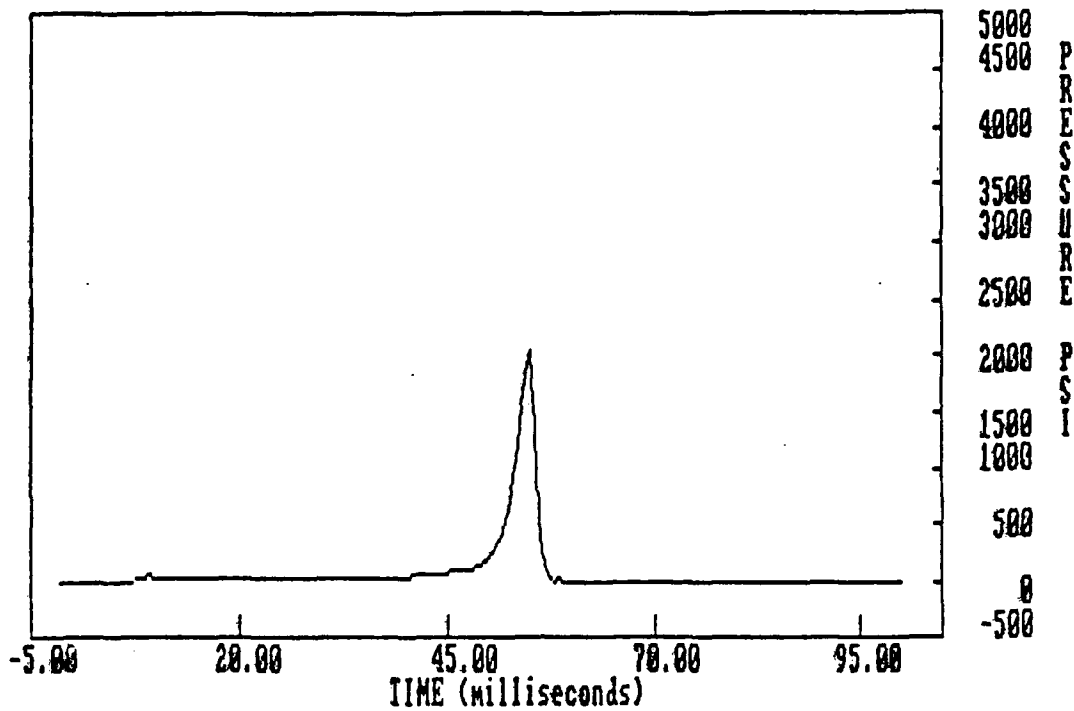

Figure 72. Live test, configuration 4 rear pressure transducer

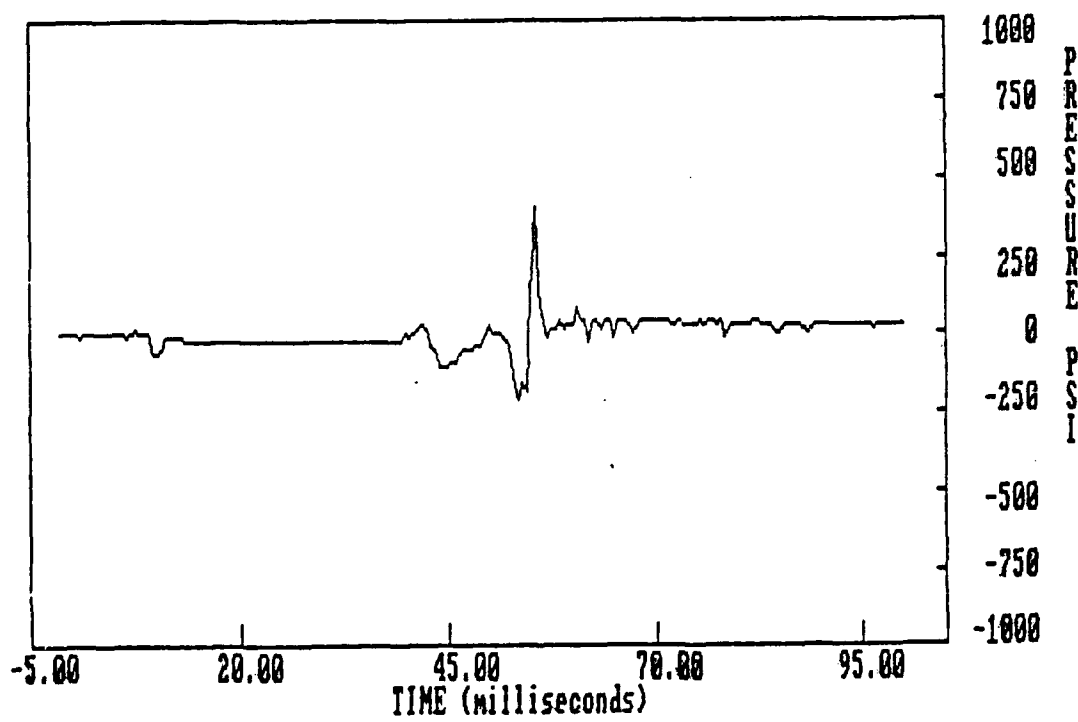

Figure 73. Live test, configuration 4 pressure difference (rear-front)

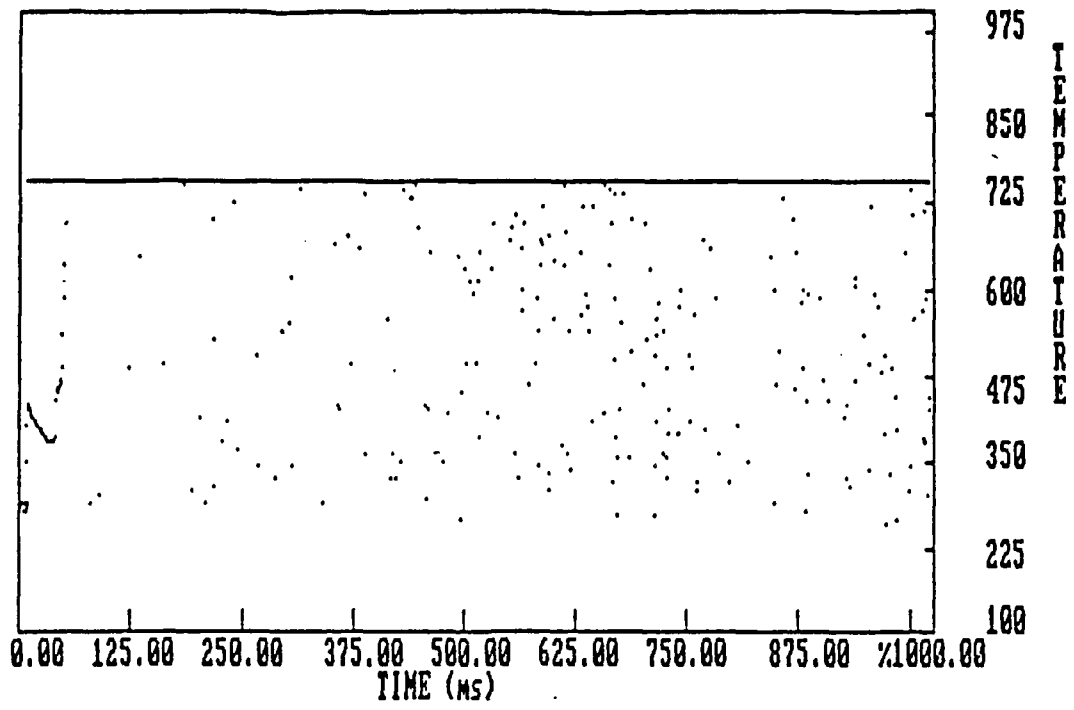

Figure 74. Live test, configuration 4 all four thermocouples

## CONCLUSIONS

The results of this program may be summarized as follows:

- A laser ignited multiple-point ignition system has been tested in a simulator. The test was successful in igniting both M30 and LOVA propellants.
- In every test reported, all ignition points functioned. This attests to the viability of the system for future multiple-point development.
- The system demonstrated a short delay time capability when used with LOVA propellant. When used with M30, unacceptably long delay times were found when the system was compared with the M83 center core ignitors.
- The 10% to 90% pressure rise times were consistent with the M83 as were the peak pressures reached.

## RECOMMENDATIONS

A need for the following has been demonstrated:

- Ignitor cases that are combustible and can hold higher pressures. These will allow for faster function times, which are needed for example with benite.
- Examination of other pyrotechnics to replace black powder.
- Development of high power laser diode arrays that could provide the required power for ignition in very small packages with lower electrical power requirements and greater reliability.

## DISTRIBUTION LIST

Commander

Armament Research, Development and Engineering Center

ATTN: SMCAR-IMI-I (5)

SMCAR-AEE

SMCAR-AEE-B (10)

SMCAR-CCH-T, L. Rosendorf

SMCAR-CCH-V, E. Fennel

Picatinny Arsenal, NJ 07806-5000

Commander

U.S. Army Armament, Munitions and Chemical Command

ATTN: AMSMC-GCL (D)

Picatinny Arsenal, NJ 07806-5000

Project Manager

Tank Main Armament System

ATTN: AMCPM-TMA, K. Russell

AMCPM-TMA-105

AMCPM-TMA-120

Picatinny Arsenal, NJ 07806-5000

Administrator

Defense Technical Information Center

ATTN: Accessions Division (12)

Cameron Station

Alexandria, VA 22304-6145

Director

U.S. Army Materiel Systems Analysis Activity

ATTN: AMXSY-MP

Aberdeen Proving Ground, MD 21005-5066

Commander

Chemical Research, Development and Engineering Center

U.S. Army Armament, Munitions and Chemical Command

ATTN: SMCCR-MSI

Aberdeen Proving Ground, MD 21010-5423

Commander  
Chemical Research, Development and Engineering Center  
U.S. Army Armament, Munitions and Chemical Command  
ATTN: SMCCR-RSP-A  
Aberdeen Proving Ground, MD 21010-5423

Director  
Ballistic Research Laboratory  
ATTN: AMXBR-OD-ST  
Aberdeen Proving Ground, MD 21005-5066

Chief  
Benet Weapons Laboratory, CCAC  
Armament Research, Development and Engineering Center  
U.S. Army Armament, Munitions and Chemical Command  
ATTN: SMCAR-CCB-TL  
Watervliet, NY 12189-5000

Commander  
U.S. Army Armament, Munitions and Chemical Command  
ATTN: SMCAR-ESP-L  
Rock Island, IL 61299-6000

Director  
U.S. Army TRADOC Systems Analysis Activity  
ATTN: ATTA-SL  
White Sands Missile Range, NM 88002

Commander  
U.S. Army Harry Diamond Laboratory  
ATTN: DELHD-TA-L  
2800 Powder Mill Road  
Adelphi, MD 20783

Commander  
U.S. Army Research Office  
ATTN: Technical Library  
P.O. Box 12211  
Research Triangle Park, NC 27709-2211

Naval Research Laboratory  
Technical Library  
Washington, DC 20375

Princeton Combustion Research Laboratory  
ATTN: M. Summerfield  
4275 U.S. Highway One  
Monmouth Junction, NJ 08852

Veritay Technology, Inc.  
4845 Millersport Highway  
P.O. Box 305  
East Amherst, NY 14051-0305

Johns Hopkins University  
Applied Physics Laboratory Chemical Propulsion  
Information Agency  
ATTN: T. Christian  
Johns Hopkins Road  
Laurel, MD 20707

SRI International  
Propulsion Sciences Division  
ATTN: Technical Library  
333 Ravenswood Avenue  
Menlo Park, CA 94025

Director  
Los Alamos National Laboratory  
ATTN: M. Division, B. Craig  
T-3 MS B216  
Los Alamos, NM 87545