

1

FILE COPY

DNA 4007T-JBH-SAN

# COMMUNICATION FACILITY EMP ASSESSMENT

AD-A206 715

Boeing Aerospace Company  
P.O. Box 3999  
Seattle, Washington 98124

Document released under the  
Disposal of Information Act.  
Unl. Cat. 87-2

30 March 1979

Topical Report for Period 1 September 1975-30 March 1979

CONTRACT No. DNA 001-76-C-0076

**S** DTIC  
ELECTE **D**  
MAR 29 1989  
**D**

THIS WORK SPONSORED BY THE DEFENSE NUCLEAR AGENCY  
UNDER ROT&E RMSS CODE 8383078462 G37KAXEX47517 H75800

Prepared for  
Director  
DEFENSE NUCLEAR AGENCY  
Washington, D. C. 20305

DISTRIBUTION STATEMENT A  
Approved for public release  
Distribution Unlimited

8 11 08 03A

Encl. 7

## **DISCLAIMER NOTICE**

**THIS DOCUMENT IS BEST QUALITY PRACTICABLE. THE COPY FURNISHED TO DTIC CONTAINED A SIGNIFICANT NUMBER OF PAGES WHICH DO NOT REPRODUCE LEGIBLY.**

REPORT DOCUMENTATION PAGE		READ INSTRUCTIONS USE REVERSE SIDE OF THIS FORM
REPORT NUMBER DNA A007T-JBM-SAN	SECURITY ACCESSION NO.	1. REPORT DATE Topical Report for Period 1 Sep 75 - 30 Mar 79
TITLE COMMUNICATION FACILITY EMP ASSESSMENT	2. AUTHOR SVGN Engineering Staff	3. CONTRACT OR ORDER NUMBER BRA 001-76-C-0076
4. PERFORMING ORGANIZATION NAME AND ADDRESS Boeing Aerospace Company P.O. Box 3999 Seattle, Washington 98124	5. PERFORMING ORGANIZATION REPORT NUMBER Subcontract G37KAZEX475-17	6. REPORT DATE 30 March 1979
7. AUTHOR Director Defense Nuclear Agency Washington, DC 20305	8. SECURITY CLASSIFICATION OF THIS REPORT [REDACTED]	9. SECURITY CLASSIFICATION OF THIS REPORT [REDACTED]
10. SUBJECT TERMS [REDACTED]		
11. DISTRIBUTION STATEMENT [REDACTED]		
12. SUPPLEMENTARY NOTES This work sponsored by the Defense Nuclear Agency under DOTGE RMSS Code 8363078462 G37KAZEX47517 M2590.		
13. KEY WORDS Electromagnetic Pulse (EMP)      Upset Threshold Hardening Concept                  Damage Thresholds Safety Margin                          Critical Equipment Survival Confidence                  Hardening Design Package		
14. ABSTRACT This report presents an assessment of the [REDACTED] to high-altitude EMP based upon electromagnetic analysis, functional analysis, and operational performance requirements. [REDACTED]		

[REDACTED]

[REDACTED]

[REDACTED]

**SUMMARY**

A scenario variant EMP assessment has been performed for the [REDACTED]. The assessment considered the effects induced by EMP environments generated by high-altitude nuclear detonations. The scenario variant technique identifies the critical electrical/electronic equipment which will be impaired by the largest signals induced within the facility by any high-altitude nuclear EMP environment.

[REDACTED]

Electromagnetic pulse hardening is recommended to insure that all critical equipments will maintain their operational capabilities during and after an EMP illumination of the facility. Hardening design packages are provided such that, if implemented, the functional capabilities of the facility will survive the most severe high-altitude EMP with [REDACTED] percent, or greater, confidence.

Accession For	
NTIS CRA&I	<input checked="" type="checkbox"/>
DTIC TAB	<input type="checkbox"/>
Unannounced	<input type="checkbox"/>
Justification	
By <i>per [signature]</i>	
Distribution	
Availability Codes	
Dist	Avail and/or Special
A-1	



[REDACTED]

[REDACTED]

**TABLE OF CONTENTS**

<u>Section</u>	<u>Page</u>
SUMMARY	1
LIST OF ILLUSTRATIONS	3
LIST OF TABLES	3
1.0 INTRODUCTION	5
1.1 BACKGROUND	5
1.2 SCOPE	6
2.0 PREDICTED EQUIPMENT VULNERABILITY AND MISSION IMPACT	7
2.1 PREDICTED UPSET EQUIPMENT AND FUNCTIONAL IMPACT	7
2.2 PREDICTED DAMAGED EQUIPMENT AND FUNCTIONAL IMPACT	7
2.2.1 Predicted Damaged Equipment	7
2.2.2 Predicted Functional Impact	9
2.3 PREDICTED IMPACTS TO [REDACTED] FACILITY MISSION	9
2.3.1 Mission Impact Due to Damage	9
2.4 NETWORK IMPACTS	10
2.4.1 [REDACTED] Network	11
2.4.2 [REDACTED] Network	11
3.0 FACILITY HARDENING	12
3.1 AC POWER HARDENING CONCEPT DESIGN	16
3.1.1 AC Power System Shielding	16
3.1.2 AC Power System EMP Suppression	19
3.2 SIGNAL INPUT HARDENING CONCEPT DESIGN	21
3.2.1 Signal Input EMP Suppression	21
APPENDIX A FACILITY DESCRIPTION	27
APPENDIX B FUNCTIONAL DESCRIPTION	33
APPENDIX C ELECTROMAGNETIC ANALYSIS	47
APPENDIX D EMP ASSESSMENT PREDICTIONS	53
APPENDIX E BONDING AND ASSEMBLY INSTRUCTIONS	57

[REDACTED]

**LIST OF ILLUSTRATIONS**

<u>Figure</u>		<u>Page</u>
2.2-1	[REDACTED] functional flow diagram showing, equipment predicted to be damaged at [REDACTED]	8
3.0-1	Conceptual installation of hardening modifications	14
3.1-1	AC power hardening installation; timer room outside wall	17
3.2-1	Signal cable suppressor installation; timer room outside wall	24
3.2-2	Suppressor installation on [REDACTED] receive antennas	25
A.1-1	Plot plan for [REDACTED] facility	28
A.1-2	[REDACTED] signal-power building timer room layout, [REDACTED]	29
A.1-3	[REDACTED] transmitter building layout, [REDACTED]	31
B.1-1	[REDACTED] chain	34
B.1-2	[REDACTED] functional flow diagram (standard configuration)	36
B.1-3	[REDACTED] equipment connectivity, [REDACTED]	38
B.2-1	[REDACTED] functional flow diagram	41
C.1-1	Major penetrations and coupling paths diagram, [REDACTED]	48

**LIST OF TABLES**

<u>Table</u>		<u>Page</u>
3.0-1	[REDACTED] hardening recommendations	i3
3.1-1	AC power system shielding, list of materials	18
3.1-2	AC power system EMP suppression; list of material	20
3.2-1	Signal input EMP suppression, list of material	23
B.2-1	[REDACTED] critical equipment functional response matrix,	43
D.2-1	Scenario variant assessment predictions for critical equipment at [REDACTED]	54

[REDACTED]

THIS PAGE LEFT INTENTIONALLY BLANK.

[REDACTED]

[REDACTED]

## 1.0 INTRODUCTION

### 1.1 BACKGROUND

The Commander-in-Chief [REDACTED] and the Defense Nuclear Agency (DNA) have undertaken an Assessment of [REDACTED] Communications for Hardening to Electromagnetic Pulse [REDACTED] to assess the vulnerability of the [REDACTED] Command's [REDACTED] Command, Control, Communications and Computer (C<sup>4</sup>) Networks to electromagnetic pulses from high altitude nuclear bursts and to provide recommendations for hardening as may be required. [REDACTED] Networks are used to link [REDACTED] with the National Command Authority (NCA), subordinate and component headquarters, and the [REDACTED] forces.

The Boeing Aerospace Company has developed and validated analytical techniques to predict the functional responses of a communications facility to the electromagnetic pulse (EMP) environments produced by a high-altitude nuclear weapon detonation scenario. The analytical capability has been applied to selected elements of the [REDACTED] C<sup>4</sup> Networks to develop response predictions in terms of upset and damage of facility equipment and functional impairments of facility communications capabilities.

This report concerns the [REDACTED] facility at [REDACTED], specifically the [REDACTED] and the [REDACTED] transmitting systems. [REDACTED] is used for U.S. Navy Fleet Broadcasts, and the [REDACTED] is a navigational aid for ships and aircraft. The [REDACTED] facility is part of the [REDACTED] chain consisting of [REDACTED] and [REDACTED], and [REDACTED] and [REDACTED].

An on-site survey was conducted during September 1977 to determine the EMP features and element descriptions for use in the facility analysis. Equipment configuration and operational data were gathered and used to develop the electromagnetic coupling and functional analyses of specified critical equipment. Computer models were developed to calculate the waveforms induced by EMP at significant terminals on critical equipment. The peak amplitudes of the waveforms were compared to calculated equipment damage and upset thresholds to predict the probability of the equipment surviving a most severe EMP event.

[REDACTED]

## 1.2 SCOPE

This report presents the element descriptions, functional analyses, element response assessments to the most severe high-altitude nuclear EMP environment, and hardening techniques and concept design packages for the LF and HF receiving and the [REDACTED] transmitting systems at the [REDACTED] facility at [REDACTED]

Hardening techniques and concept designs have been developed for each piece of critical equipment predicted to be vulnerable to the most severe high altitude nuclear EMP environment. The hardening techniques and concept designs are expected to reduce or nullify the EMP effects, thus assuring critical equipment survivability to at least the [REDACTED] percent confidence level. The hardening designs consider the ease of installing and maintaining the hardening devices, cost, and non-interference to normal, daily operations.

[REDACTED]

2.0 [REDACTED] PREDICTED EQUIPMENT VULNERABILITY AND MISSION IMPACT [REDACTED]

[REDACTED]

[REDACTED] Specific assessment values for the critical equipment are listed in Appendix D, "EMP Assessment Predictions."

2.1 [REDACTED] PREDICTED UPSET EQUIPMENT AND FUNCTIONAL IMPACT [REDACTED]

[REDACTED]

2.2 [REDACTED] PREDICTED DAMAGED EQUIPMENT AND FUNCTIONAL IMPACT [REDACTED]

2.2.1 [REDACTED] Predicted Damaged Equipment [REDACTED]

[REDACTED]

[REDACTED]

[REDACTED]

[REDACTED]

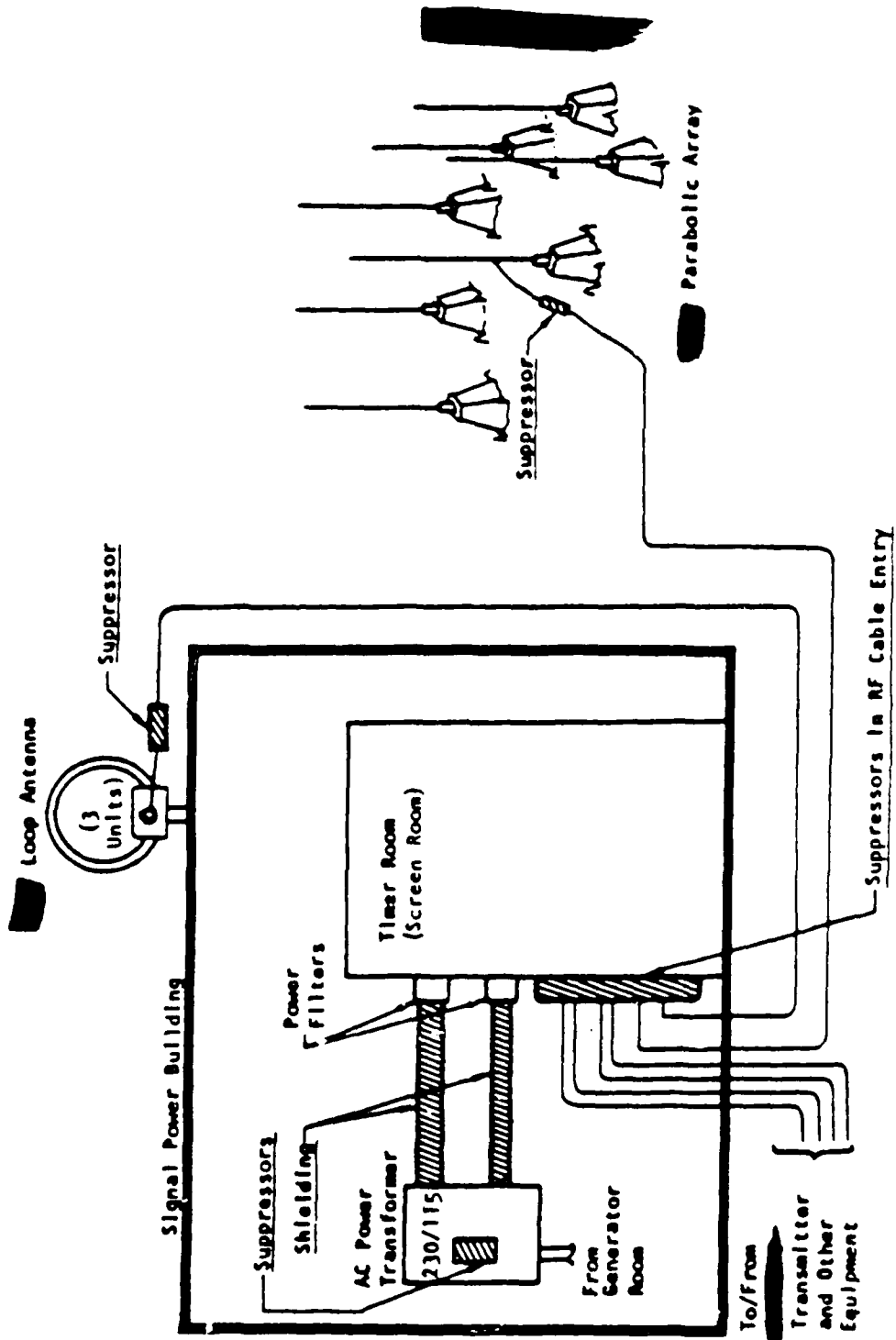

Figure 3.0-1. Conceptual installation of hardening modifications.

[REDACTED]

[REDACTED] The remaining material in this section defines conceptual designs for the hardening techniques recommended for installation in the [REDACTED] facility. The information presented includes recommended design requirements, material specifications, and installation instructions for each hardening concept. The hardening requirements are such that the modifications can be readily installed by on-site personnel. Some inspections by on-site personnel will be required to determine the proper equipment to be ordered.

[REDACTED]

### 3.1 [REDACTED] AC POWER HARDENING CONCEPT DESIGN [REDACTED]

#### 3.1.1 [REDACTED] AC Power System Shielding [REDACTED]

[REDACTED]

[REDACTED]

[REDACTED]

3.1.1.2 [REDACTED] Material Requirements. [REDACTED] An estimated list of material is shown in Table 3.1-1. The list also provides expected costs and potential suppliers.

3.1.1.3 [REDACTED] Installation Requirements. [REDACTED] Remove the existing power conductor installation in the steel duct between the transformer case and the power filters. Install rigid steel conduit between the transformer case and the filters (see Figure 3.1-1). Assemble the conduit and fittings in accordance with Appendix E, Sections E.2.1 and E.2.2. Reconnect the transformer secondary to the power filter input terminals.

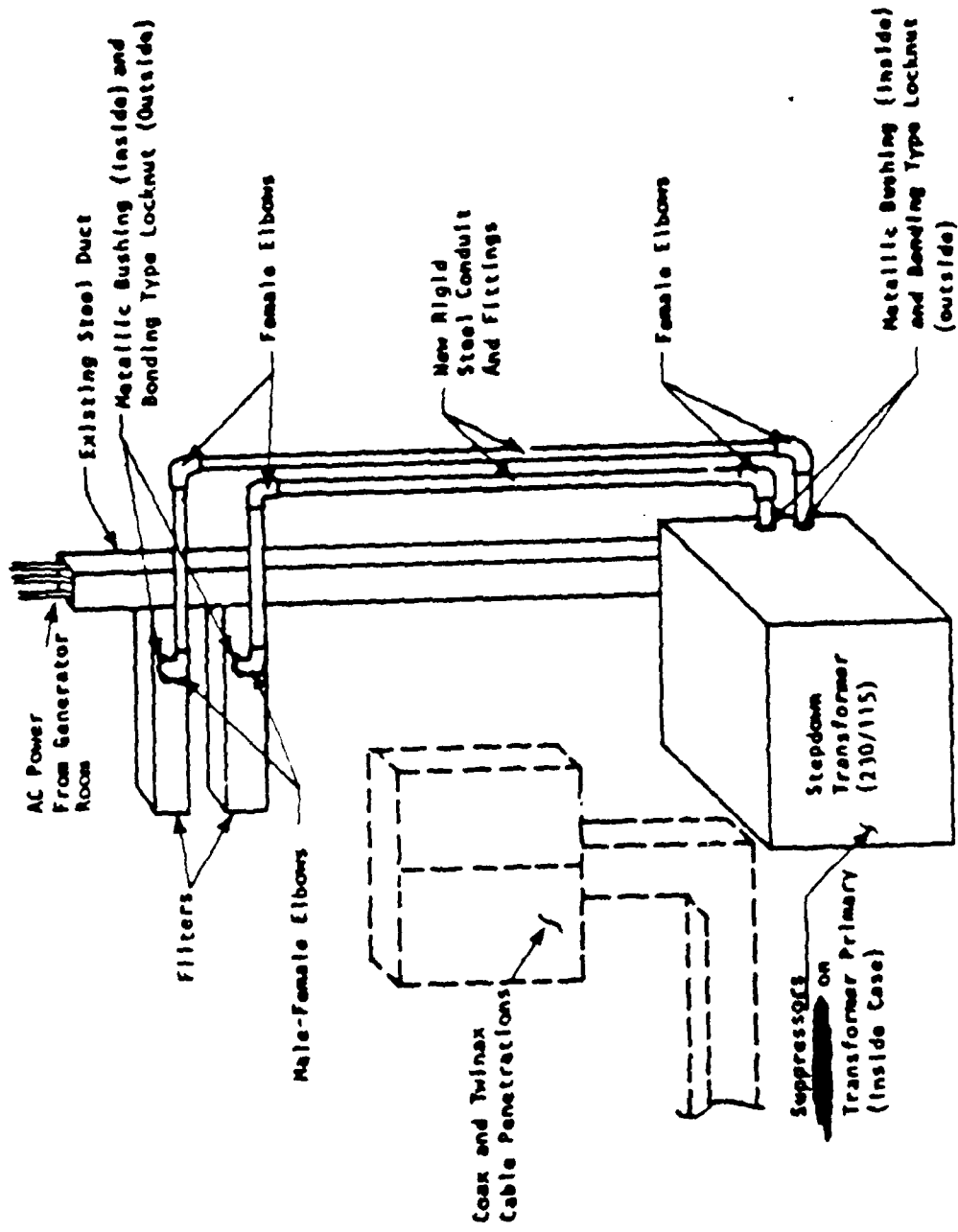

Figure 3.1-1. AC power hardening installation: timer room outside wall.

Table 3.1-1. AC power system shielding, list of materials.

Item	Description	Supplier	Estimated Quantity		Approximate Cost/Unit	Total
			Per/Unit	Units		
1	Rigid Steel Conduit, 1" dia., galvanized	①	10 Ft.	2	515.00	530.00
2	Rigid Steel Conduit, 1" dia., galvanized or zinc plated, 90° male + female elbow - Crouse Hinds EI 396	①	2	1	8.20	8.20
3	Rigid Steel Conduit, 1" dia., galvanized or zinc plated, 90° female elbow - Crouse Hinds EI 39	①	4	1	12.40	12.40
4	Bonding type Locknut, T&B 143, Steel City LN-103, or Appleton BL-100	①	4	1	2.00	2.00
5	Metallic Bushing, T&B 124, Steel City BU-403, or Appleton BU-100	①	4	1	2.00	2.00
6	Galvicon, Cold Galvanizing Compound Kenco Div., Southern Coatings & Chemical Co. Sumter, South Carolina 29150	①	---	1 Ft	4.10	4.10
7	Miscellaneous Hardware ②	①	---	---	10.00	10.00
						568.70

NOTES:

- ① Obtain from the nearest available source.
- ② Determine type, size, and quantity from existing installation and implementation of hardness design.

[REDACTED]

3.1.2 [REDACTED] AC Power System EMP Suppression [REDACTED]

[REDACTED]

[REDACTED]

[REDACTED]

3.1.2.2 [REDACTED] Material Requirements. [REDACTED] The estimated list of material is in Table 3.1-2. The list also provides expected costs and potential suppliers.

[REDACTED]

[REDACTED]

Table 3.1-2. (v) AC power system EMP suppression, list material. (u)

Item	Description	Supplier	Estimated Quantity		Approximate Cost/Unit	Total
			Per/Unit	Units		
1	Suppressor [REDACTED]	①	2	1	\$70.00	\$70.00
2	Miscellaneous Hardware ③ [REDACTED]	②	---	---	5.00	5.00
						\$75.00
①	NOTES: [REDACTED]					
②	Obtain from the nearest available source.					
③	Determine size, type, and quantity from existing installation and implementation of hardening design.					

[REDACTED]

3.2 [REDACTED] SIGNAL INPUT HARDENING CONCEPT DESIGN [REDACTED]

3.2.1 [REDACTED] Signal Input EMP Suppression [REDACTED]

[REDACTED]

[REDACTED]

[REDACTED]

[REDACTED]

[REDACTED]

[REDACTED]

[REDACTED]

[REDACTED]

3.2.1.2 Material Requirements. An estimated list of material is shown in Table 3.2-1. The list also provides expected costs and potential suppliers.

[REDACTED]

[REDACTED]

[REDACTED]

[REDACTED]

[REDACTED]

Table 3.2-1. (u) Signal input EMP suppression, list of material. (u)

Item	Description	Supplier	Estimated Quantity		Approximate Cost/Unit	Total
			Per/Unit	Units		
1	[REDACTED]	①	2	1	\$70.00	\$70.00
2	[REDACTED]	①	1	1	35.00	35.00
3	[REDACTED]	①	9	1	315.00	315.00
4	Suppressor (*) Part number must be completed after on-site inspection before parts can be ordered. Insert M, BMC, TWINAX in place of (*) suffix to complete part number.	①	4	1	120.00	120.00
5	1/8" Copper Sheet, for Brackets ①	②	---	---	40.00	40.00
6	Connectors, Miscellaneous, for Suppressor Mounting ①	②	---	---	50.00	50.00
7	Dow Corning 3145 RTV Adhesive/Sealant (Non-corrosive)	③	---	1 Pint	22.00	22.00
8	Miscellaneous Hardware ④	②	---	---	30.00	30.00
①	NOTES: [REDACTED]					5682.00
②	Obtain from nearest available source.					
③	Dow Corning Corp., Midland, Michigan 48640					
④	Determine amount, type, size, quantity, etc., from existing installation and implementation of hardness design.					

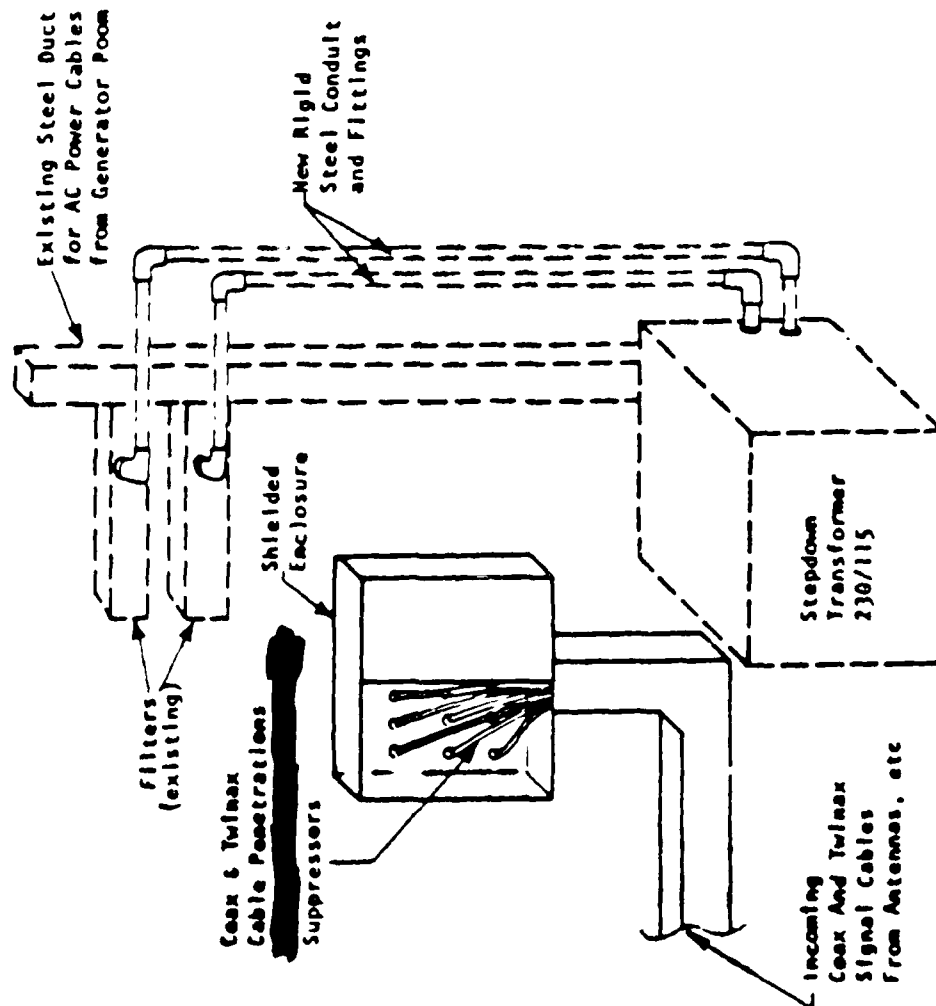
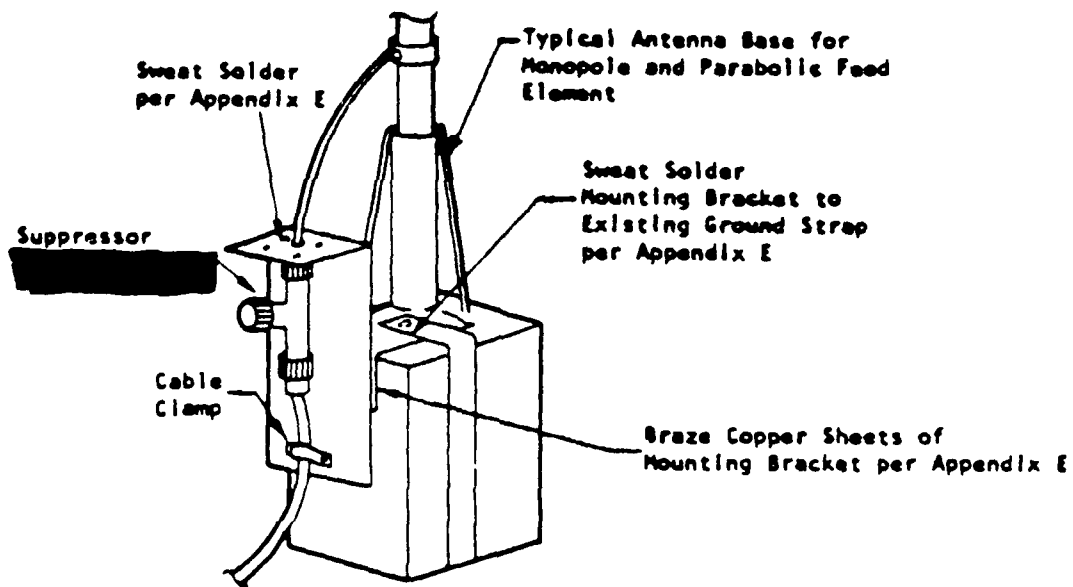
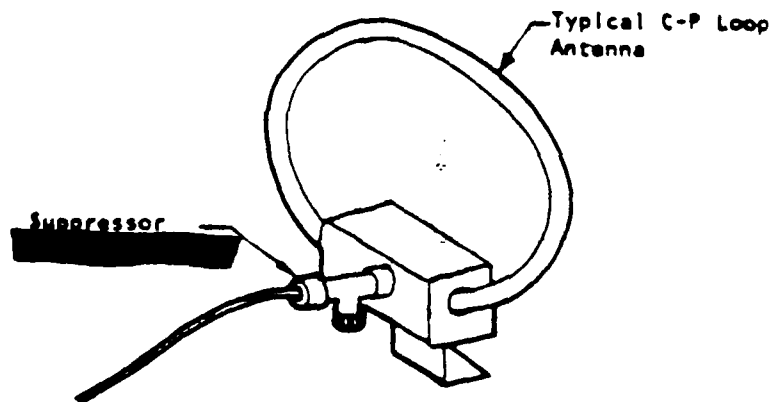

Figure 3.2-1. Signal cable suppressor installation; timer room outside wall.



Suggested installation for monopole and parabolic feed elements. Mounting bracket to be made of 1/8" copper sheet. Assemble coaxial cable and fittings per Appendix E, Severe Environment.



Suggested installation for loop antenna. Assemble coaxial cable and fittings per Appendix E, Severe Environment.

Figure 3.2-2. Suppressor installation on receive antennas.

[REDACTED]

[REDACTED] APPENDICES

The following appendices provide complementary information concerning this assessment of the [REDACTED] facility:

- Appendix A: Facility Description
- Appendix B: Functional Description
- Appendix C: Electromagnetic Analysis
- Appendix D: EMP Assessment Predictions
- Appendix E: Bonding and Assembly Instructions

[REDACTED]

[REDACTED]

APPENDIX A  
FACILITY DESCRIPTION

A.1 GENERAL

The [REDACTED] station is located on the [REDACTED]. It is operated and maintained by the U.S. Coast Guard, and it is part of the [REDACTED] chain. The other [REDACTED] facilities are located at [REDACTED].

A.1.1 Facility Layout

Figure A.1-1 shows the layout of the [REDACTED] facility. Equipment associated with the [REDACTED] and [REDACTED] systems are located in either the signal power building or transmitter building. The signal power building contains the [REDACTED] signal receivers and equipment, the [REDACTED] timer, and power generating equipment. The transmitter building contains two high-power [REDACTED] transmitters, an antenna coupler, dummy load, and incoming ac power transformers. The buildings are constructed of reinforced concrete block walls and prestressed concrete slab roofs.

Other parts of the installation include personnel barracks, water and sewage facilities, an oil storage tank farm, antennas, and interconnecting conductors.

A.1.2 Equipment Layout

The signal power building is a one-story, reinforced, concrete block structure, providing a measured 11 dB attenuation to free-field E.R.P. The [REDACTED] equipment is located inside the timer room, measuring 6 meters x 6 meters x 2.5 meters (20 ft x 20 ft x 8 ft). The timer room provides a measured total of 35 dB attenuation to the electromagnetic environment outside the signal power building. Figure A.1-2 shows a floor plan of the signal power building timer room.

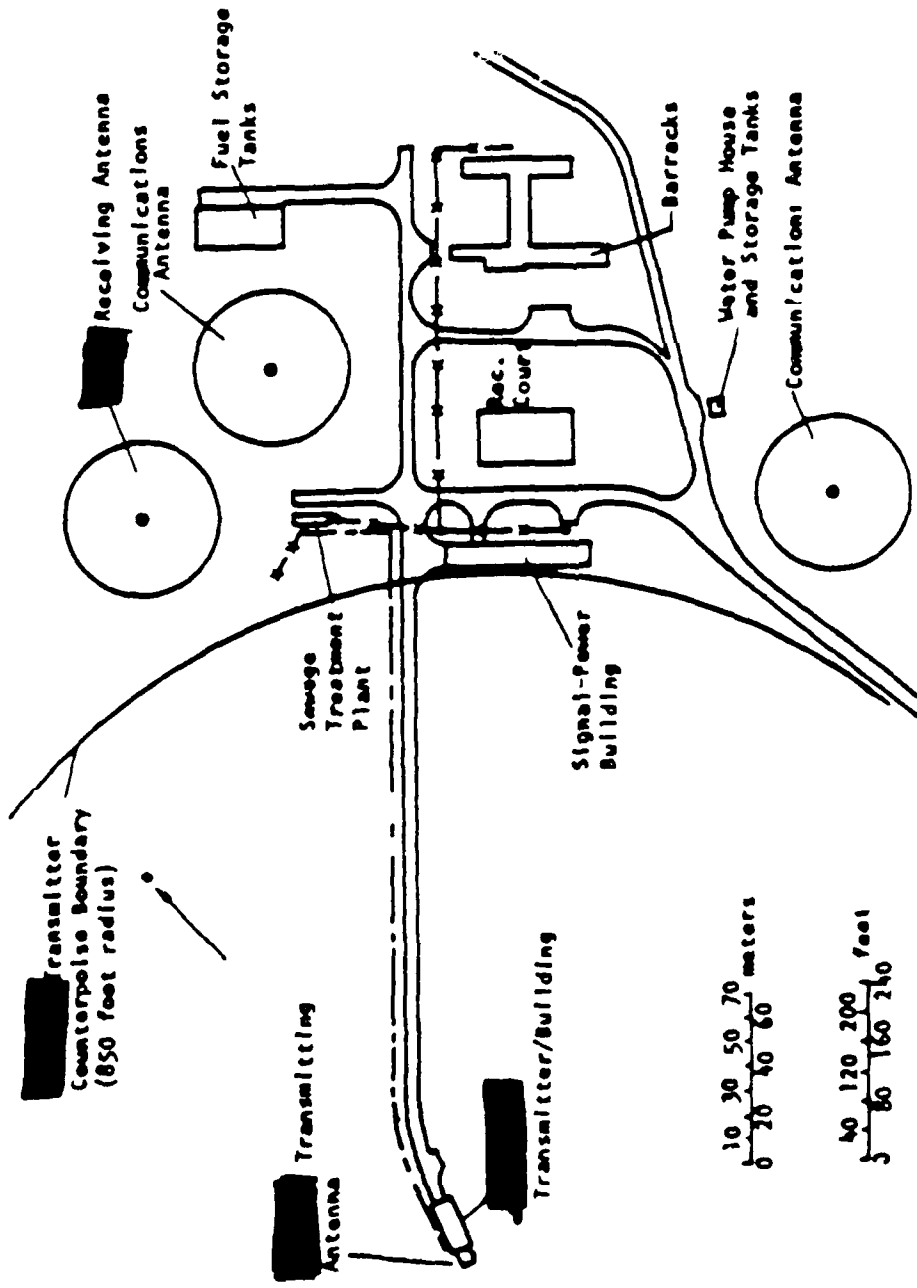

Figure A.1-1. Plot plan for [redacted] facility.

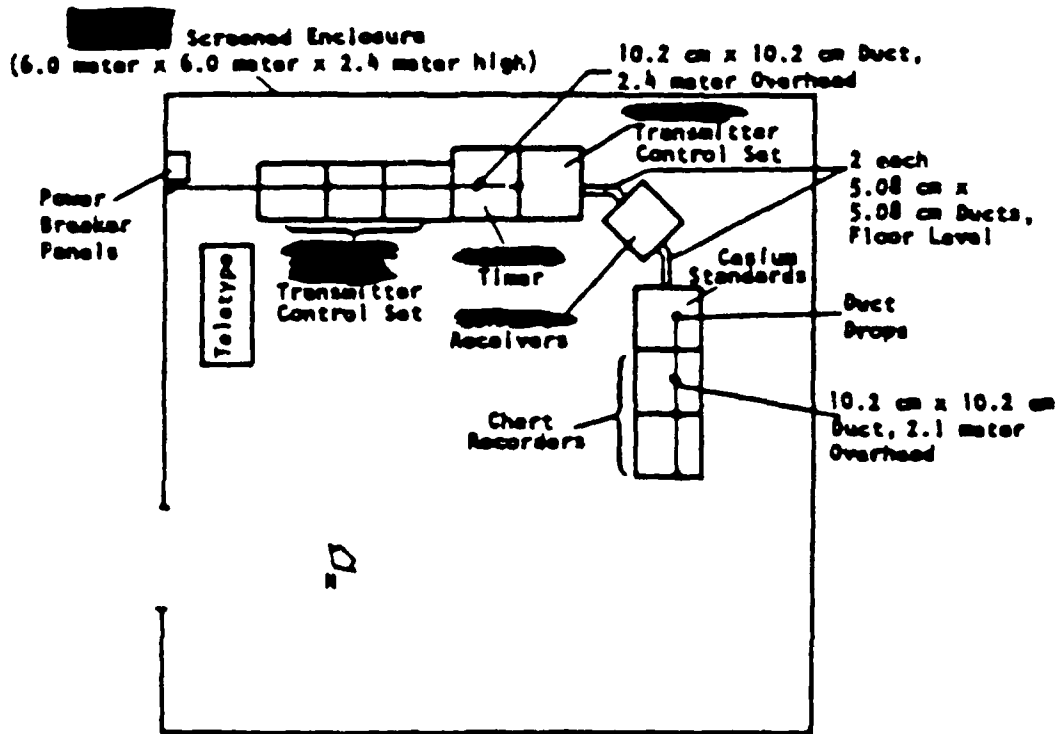

Figure A.1-2. [redacted] signal-power building timer room layout, [redacted]

[REDACTED]

The timer room contains a complete [REDACTED] equipment installation: one [REDACTED] timer set, one [REDACTED] transmitter control set, one [REDACTED] frequency standard rack, one recorder rack, and one auxiliary equipment rack. Also located in the room is an [REDACTED] transmitter control set for receiving and retransmitting the HF and LF messages by modulating the [REDACTED] signal.

The [REDACTED] transmitter building is a specially shielded concrete block structure located 262 meters (860 feet) southwest of the signal power building. The transmitter building houses two [REDACTED] transmitters. Special shielding is required to protect the [REDACTED] electronics equipment from the 100 kHz electromagnetic fields radiated from the [REDACTED] transmit antenna. The [REDACTED] signal is routed from the signal power building to the transmitter building via two buried twinax cables. The transmitter building structure provides [REDACTED] attenuation to free-field EMP. The [REDACTED] transmit antenna is located 10 meters (33 feet) southwest of the transmitter building. The base of the transmit antenna is tied into a 259 meter (850 foot) radius ground counterpoise system. Figure A.1-3 shows the layout of the transmitter building.

[REDACTED] signal and control cables between the timer room and the transmitter building are buried. Included in these cables are seven twinax signal cables (the two twinax transmitter drive cables are contained in copper tubing) and two shielded 12-wire control cables. The twinax cables enter the timer room by way of the feed-through box. The control cable shields are grounded in the floor trench at both ends and the wires are fed through capacitors at the input to the timer room.

Separate ground systems are used for the two buildings. The ground for all equipment and power circuitry in each building is provided by a buried ground system around the building periphery consisting of 3 meter long ground rods, 2 centimeters in diameter, spaced at intervals not exceeding 3 meters, connected by 2 centimeter diameter copper tubing.

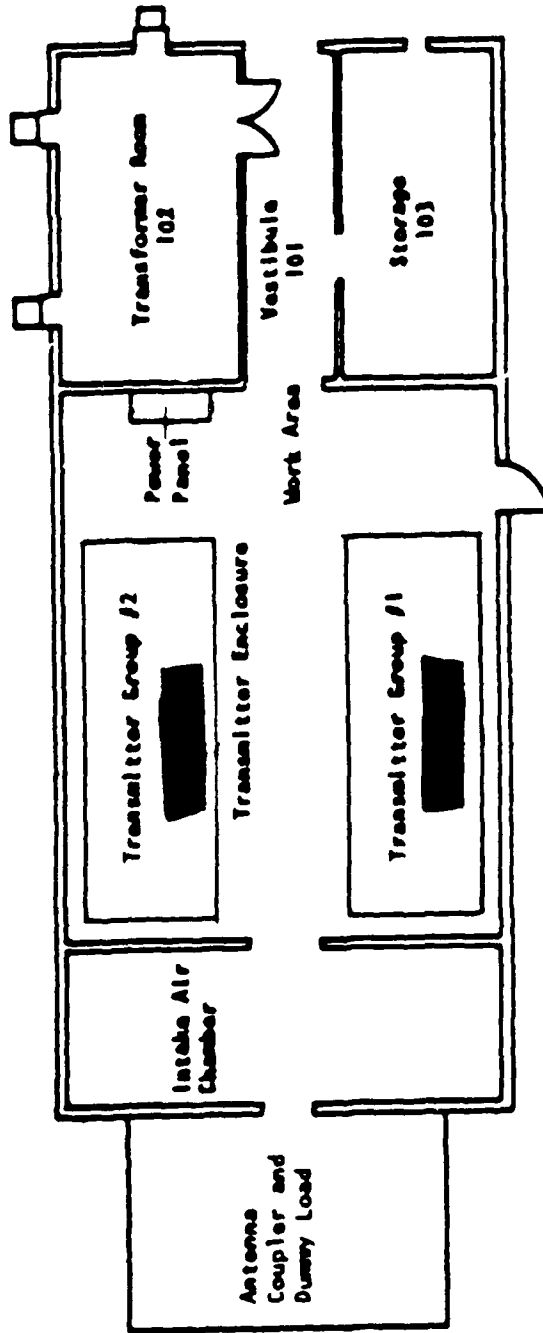

Figure A.1-3. [redacted] transmitter building layout, [redacted]

[REDACTED]

[REDACTED] receive antennas are mounted on the roof of the signal power building, and coaxial cables route from the receive antennas through a bulk-head feedthrough panel into the screen room and to the radio receivers. The [REDACTED] facility uses three [REDACTED] cesium frequency standards for [REDACTED] timing. In addition, [REDACTED] receives a master timing signal from [REDACTED] as backup timing for the cesium standards.

The LF signals are received by two passive loops and one active loop located on the signal power building roof. HF signals are received by a parabolic array [REDACTED] of the signal power building. [REDACTED] signals used for signal monitoring and timing are received by an active loop also located on the signal power building roof. A [REDACTED] vertical antenna, located just outside the transmitter building, is used for transmitting the [REDACTED] signal.

The twinax cables for the LF loops penetrate the signal power building wall at a height of 3 meters (10 feet) and are routed above the timer room to the feed-through box on the timer room wall. The HF parabolic array coax cable is routed below ground until it penetrates the wall of the building; the cable then follows the same route as the twinax cables. The [REDACTED] antenna twinax cable penetrates the [REDACTED] wall near the floor and is routed in a cable tray to the feed-through box.

AC power for the facility is supplied by any one of three 350 kW/208 volt diesel generators located in the central portion of the signal power building.

The ac power to the timer room is routed through overhead plastic conduits from the main power panel in the generator room. At the input to the room, the power passes through a 208/120 volt transformer and isolation filters.

The transmitter building ac power is routed from the main power panel in the generator room to a 208/4160 volt transformer in the same room. The power is then routed by buried cables in a trench to the 4160/440 volt transformer in the transmitter building.

[REDACTED]

APPENDIX B  
FUNCTIONAL DESCRIPTION

8.1 GENERAL

The [REDACTED] system radiates a [REDACTED] pulse train from a [REDACTED] vertical antenna, with a peak radiated power of [REDACTED]. Receivers on surface ships, aircraft, and submarines use the [REDACTED] signals to determine their precise geographical positions. In addition to the navigational information, the [REDACTED] pulse train is modulated by the [REDACTED] system, superimposing Navy fleet (radio teletype) communications onto the [REDACTED] pulse train. [REDACTED] signals are received at [REDACTED] from several Navy facilities in the [REDACTED] and then retransmitted using the [REDACTED] system.

8.1.1 [REDACTED] System Description

[REDACTED] is a low-frequency radio navigation aid operating in the radio spectrum of [REDACTED]. Although primarily employed for navigation, transmissions are used for time dissemination, frequency reference, and communications. The [REDACTED] system consists of transmitting stations in groups forming chains. At least three transmitter stations constitute a chain. One station is designated master, while others are termed secondaries. Chain coverage area is determined by the transmitted power from each station and the geometry of the stations, including the distance between the stations and their orientation. Within the coverage area, propagation of the [REDACTED] signal is affected by physical conditions of the earth's surface and atmosphere. The location of the five [REDACTED] facilities are shown in Figure 8.1-1.

8.1.1.1 [REDACTED] Chain. All transmitters in the [REDACTED] system share the same radio frequency spectrum by sending out a burst of short pulses and then remaining silent for a predetermined period. Each chain within the system has a characteristic repetition interval between the pulse bursts enabling the receive equipment to be uniquely synchronized, thereby identifying the chain and the stations within the chain.

[Redacted header text]

[Redacted text]

[Large redacted block of text]

[Redacted text]

[Redacted text]

[Redacted footer text]

[REDACTED]

8.1.1.2 [REDACTED] Format. Each station in a chain is assigned a signal format based on its assigned function. The pulses consist of a [REDACTED] carrier that rapidly increases in amplitude in a carefully controlled manner and then decay at a specified rate forming an envelope of the signal. Each station repetitively transmits its series of closely spaced pulses, called a pulse group, at the group repetition interval assigned to the chain. When the chain is synchronized to Universal Time (UT), the master station also sets the time reference for the chain. The secondary stations transmit in turn following the master station transmissions. Each secondary is delayed in time so that no where in the coverage area will signals from one station overlap another. The number of pulses in a group, pulse spacing in a group, time of transmission, the time between repetition of pulse groups from a station, and the delay of secondary station pulse groups with respect to the master signals constitute the signal format.

In addition to providing a navigation service, the [REDACTED] transmission can be used for the purpose of communications. Messages for system control may be sent from station-to-station within a chain by varying certain signal format parameters of the pulse. This can be accomplished without significant adverse effect on the processing of the navigation signals in receiving equipment.

8.1.1.3 Equipment Description. The major components of the [REDACTED] transmitting equipment are described in the following paragraphs and are illustrated in Figure 8.1-2.

A [REDACTED] ground station contains a [REDACTED] transmitting set, a transmitter automatic controller, and an antenna. The function of the ground station is to develop and transmit pulsed navigational signals on a [REDACTED] carrier. There are two kinds of [REDACTED] ground stations: a low power and a high power station. A low power ground station contains a [REDACTED] transmitting set [REDACTED], a transmitter automatic controller, and a [REDACTED] antenna. The peak output power of a low power station is approximately [REDACTED]. A high power ground station contains a [REDACTED] transmitting set [REDACTED], a transmitter automatic controller and a [REDACTED] antenna. The peak output power of a high power station is approximately [REDACTED].

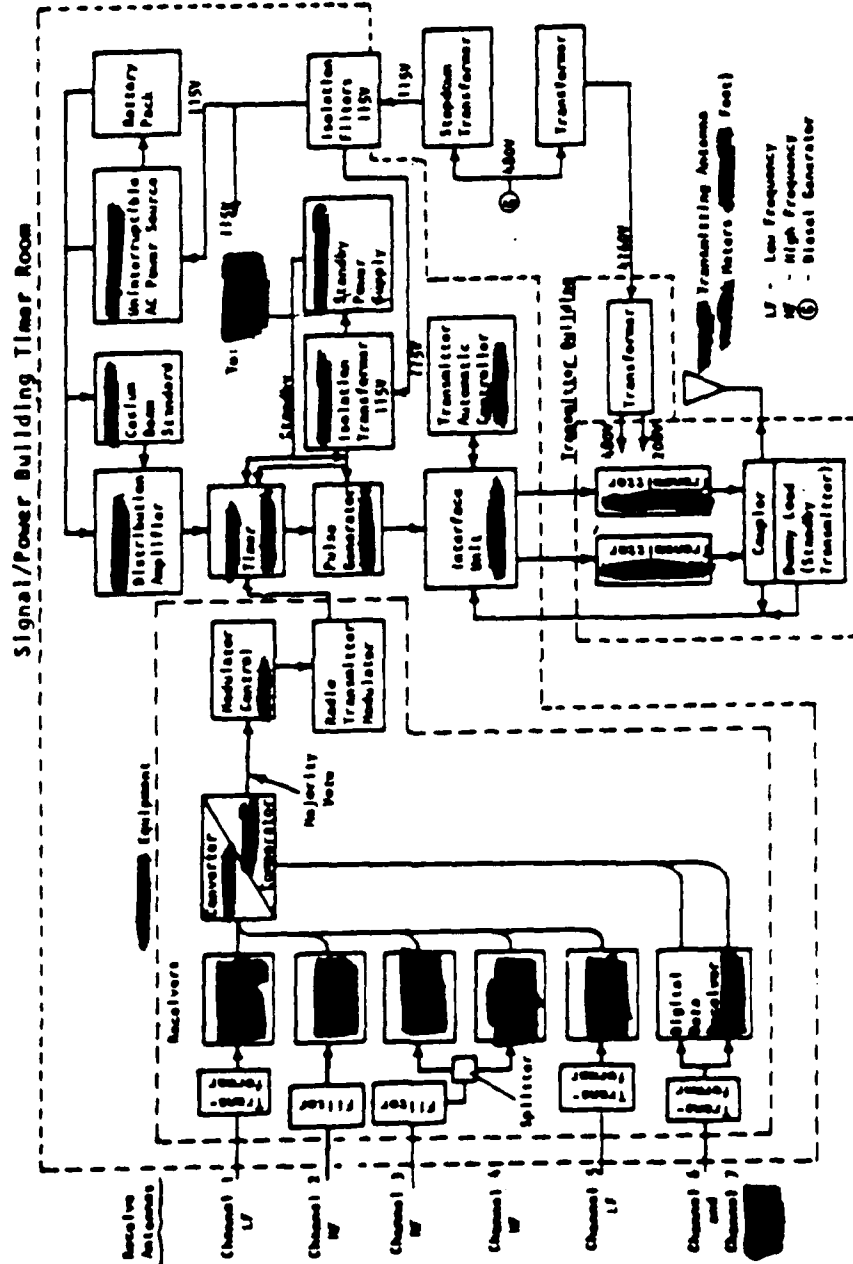

Figure B.1-2. [redacted] functional flow diagram (standard configuration).

[REDACTED]

Two transmitters are contained in a [REDACTED] transmitting set. The transmitters are always in operation: one feeding the antenna and the other on standby operation. The transmitter on standby operation has only filament voltages applied. If the active transmitter fails, the standby transmitter can be switched to the antenna. The transmitter automatic controller, located in the signal power building, provides the controls for switching the outputs of the two transmitters alternatively to either a dummy load or the site antenna. When either transmitter is feeding the antenna, the other is switched to the dummy load. The transmitters can be switched automatically or manually from the signal power building, or they can be switched manually in the transmitter building.

The transmitter automatic controller [REDACTED] contains the pulse generating circuits using inputs from the timer [REDACTED] and the timing generator equipment. There are active and standby timers, cesium beam standards, and the pulse generator units. Failure of the active equipment results in automatic switch-over to standby units.

#### B.1.2 [REDACTED] System Description

[REDACTED] is a system which superimposes U.S. Navy Fleet Broadcast messages on the [REDACTED] pulse transmissions. Its purpose is to improve the reliability of Navy communications in areas covered by [REDACTED]. The system provides this capability with minimal interference to the navigational characteristics of the [REDACTED] systems.

[REDACTED] is installed in the [REDACTED] chain [REDACTED] and uses the [REDACTED] Coast Guard transmitters located at the [REDACTED] stations. The division and interface of the [REDACTED] and [REDACTED] equipment on [REDACTED] is shown in Figure B.1-3. All five [REDACTED] stations are used.

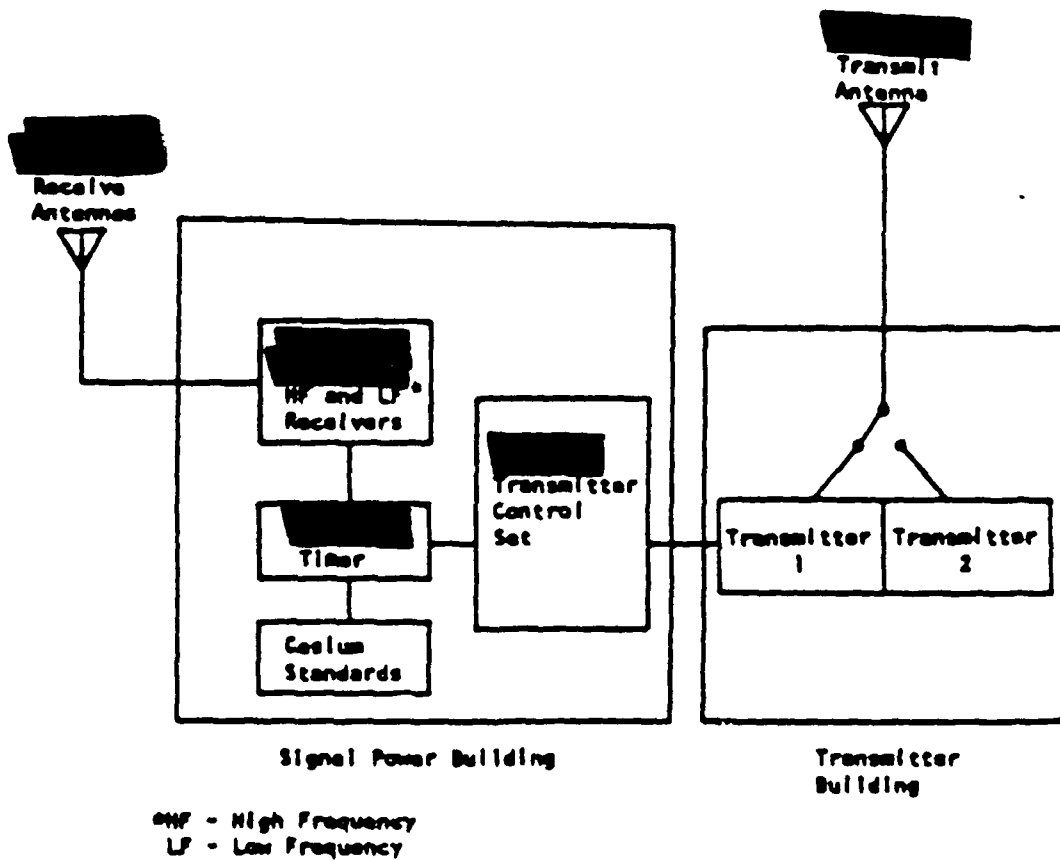

Figure B.1-3. [redacted] equipment connectivity, [redacted]

[REDACTED]

The Navy Fleet Broadcast being transmitted on the [REDACTED] system is a radio teletype stream of binary data. Similar broadcasts are transmitted from VLF, LF, and HF stations in locations such as [REDACTED] using conventional FSK transmission modes.

Normally, two HF receive antenna systems are installed at each [REDACTED] transmitter site. One system is a nondirectional whip with one HF receiver operating from the whip. The other system is a parabolic array, consisting of an active whip and nine grounded whip reflectors to provide directivity and gain. Two HF receivers operate from this array. Three VLF receive loop antennas are normally installed at each [REDACTED] transmitter site. The loops provide signals for VLF receiver-channels 1 and 5, and the digital data receiver.

The [REDACTED] transmitter set [REDACTED] is capable of receiving, converting and processing up to five radio input links at one time. It is able to process two LF or VLF signals and three HF signals. In addition to handling the five radio link channels, the signal comparator portion of the [REDACTED] transmitter set can process two [REDACTED] signals. By combining three, five or seven signals of good to fair quality in a majority-vote output, an output signal can be obtained which is generally superior to that of any single channel.

8.1.2.1 Equipment Description. The major components of the transmitter control set [REDACTED] are described in the following paragraphs and illustrated previously in Figure 8.1-2.

Five standard Navy communication receivers are supplied with the transmitter control set. Two [REDACTED] receivers are provided for receiving VLF and LF signals, and three [REDACTED] receivers are installed for HF receptions. The radio receiving set [REDACTED] is a LF dual conversion superheterodyne receiver; the [REDACTED] is a triple conversion superheterodyne receiver that provides coverage of the HF band.

[REDACTED]

The output of each receiver is fed to one of the five channels of the [REDACTED] signal data converter. Each converter channel demodulates one incoming frequency shift keyed (FSK) signal and converts the information to a digital data output.

The [REDACTED] digital data receiver acquires the master station [REDACTED] signal and any two of the secondary station [REDACTED] signals. The receiver processes the [REDACTED] signals and extracts the [REDACTED] information, providing digital data outputs to the signal comparator.

The [REDACTED] signal comparator receives seven channels of data and stores and correlates incoming digital data signals. The signal comparator can combine the correlated signals from selected channels and provide a three, five, or seven channel majority-voted output. In addition, any single input channel can be selected as the output. Five of the signal comparator channels receive inputs from the signal data converters. The other two channels are connected to the digital data receiver, providing digital information from any two of the three acquired [REDACTED] signals.

The [REDACTED] modulator control accepts the majority-voted output from the signal comparator, retimes the data to the [REDACTED] rate, and sends the retimed signal to the transmitter modulator unit. The [REDACTED] transmitter modulator accepts commands from the modulator control and phase shifts the [REDACTED] pulses.

## B.2 [REDACTED] FUNCTIONAL DESCRIPTION

The equipment functional block diagram for the [REDACTED] is shown in Figure B.2-1. Variations in the site configuration relative to the standard configuration, as defined, are shown in the figure and noted as follows:

- 1) The three MF receivers (Channels 2, 3 and 4) are all connected to the same antenna and share a single input filter.
- 2) [REDACTED] is a low power station using an [REDACTED] transmitter and [REDACTED] antenna.



[REDACTED]

The [REDACTED] transmitter site at [REDACTED] receives the two LF transmissions from [REDACTED]. Two of the MF transmissions come from [REDACTED] and the third comes from [REDACTED]. [REDACTED] signals are received from [REDACTED] and [REDACTED].

Results of the functional analysis indicate that the equipment listed in Table B.2-1 are critical for operating the [REDACTED] and [REDACTED] [REDACTED] systems. Included for each critical equipment is the functional impact to [REDACTED] operations if the equipment is impaired.

Table B.2-1. [redacted] critical equipment functional response matrix, [redacted]

Critical Equipment	Functional Response
<p>(Signal-Power Building)</p> <p>[redacted] Transmitter Control Set</p> <p>1. [redacted] VLF/LF Radio Receiving Set (2 Receiving Sets per [redacted])</p> <p>2. [redacted] General Purpose HF Receiver (3 Receivers)</p> <p>3. [redacted] Digital Data Receiver (2 Channels)</p> <p>4. Data Converter, Signal Comparator and Radio Transmitter Modulator (Signal Processing Equipment)</p>	<p>1. Damage results in loss of VLF/_F transmission from: Ch. 1 - [redacted] Ch. 5 - [redacted]</p> <p>2. Damage results in loss of HF transmission from: Ch. 2 - [redacted] Ch. 3 - [redacted] Ch. 4 - [redacted]</p> <p>3. Damage to this receiver results in loss of [redacted] signals from [redacted] and [redacted] (Ch. 6 and 7)</p> <p>4. Loss of power to the signal processing equipment results in loss of majority output signal to [redacted] timer. (NOTE: The output signal from the [redacted] is a composite majority-voted signal selected from seven receiver input signals. Failure, due to damage, of one or more receivers still leaves the [redacted] system operational.)</p>

Table B.2-1. [redacted] critical equipment functional response matrix, (continued).

Critical Equipment	Functional Response
<p>Frequency Standard Rack</p> <p>1. [redacted] Cesium Beam Standard</p> <p>2. Distribution Amplifier [redacted]</p> <p>[redacted]</p> <p>Transmitter Control Set (Transmitter Drive Waveform Output)</p> <p>(Status and Control Lines)</p>	<p>There are three cesium beam standards (operational, standby and spare). Loss of the standards result in loss of local timing and pulse generating capabilities for the [redacted] signal. The [redacted] power supply has a battery pack which is switched on automatically if the power supply is damaged. Power pack will supply the standard for 15 to 45 minutes.</p>
<p>Timer Room Filter [redacted]</p> <p>Timer Room Stepdown Transformer (Transmitter Building)</p> <p>4160 volt to 480 volt Transformer</p>	<p>Damage to the operating unit causes a switch to standby unit. Damage to the standby results in loss of the modulated [redacted] signal to the [redacted] transmitters.</p> <p>Damage results in loss of ability to monitor the status of the operational and standby [redacted] transmitters and to switch them automatically. The transmitters can be switched manually in the signal power building and/or the transmitter building.</p> <p>Damage results in outage of all [redacted] and [redacted] equipment in screen room.</p> <p>Damage results in outage of all [redacted] and [redacted] equipment in screen room.</p>
<p>[redacted]</p>	<p>There are two transformers. Loss of one results in switching to the other. Loss of both results in loss of transmission of [redacted] and [redacted]</p>

Table B.2-1. [redacted] critical equipment functional response matrix, (continued).

Critical Equipment	Functional Response
<p>[redacted] Transmitting Set                      (Transmitter Drive Waveform Inputs)                      (Status and Control Lines)</p>	<p>Damage results in loss of the modulated [redacted] signal. Loss of the operational transmitter output signal results in the automatic or manual switching to the standby transmitter would require repair for restoration of transmission.</p> <p>Loss results in ability to switch transmitter remotely and automatically.</p>



This page intentionally left blank.

[REDACTED]

APPENDIX C  
ELECTROMAGNETIC ANALYSIS

C.1 GENERAL

The [REDACTED] installation is similar to other stations of the [REDACTED] chain. Commercial ac power comes to the site, but, at the time of survey (September 1977), was not installed for supplying power to the transmitters.

There are two major buildings in the [REDACTED] facility that underwent electromagnetic analysis: the transmitter building and the signal-power building. Major penetrations and coupling paths are shown diagrammatically in Figure C.1-1.

C.1.1 Transmitter Building

The transmitter building (XB) is made of reinforced concrete blocks with copper mesh screening providing an estimated [REDACTED] of electromagnetic field shielding.

All metal work about the building is grounded to protect personnel against shock hazards from the electromagnetic fields generated by the transmitters.

C.1.2 Signal-Power Building

The Signal-Power (S-P) building contains diesel generators supplying the site ac power. The transmitter is controlled by equipment in a screen room located at the south corner of the S-P building.

The S-P building is made of reinforced concrete block with rebar tied together (in part) and connected to a buried ground ring with ground rods surrounding the building. The S-P building provides about [REDACTED] of electromagnetic field shielding while the screen room provides approximately [REDACTED], for a total of 35 dB shielding to the outside environment.

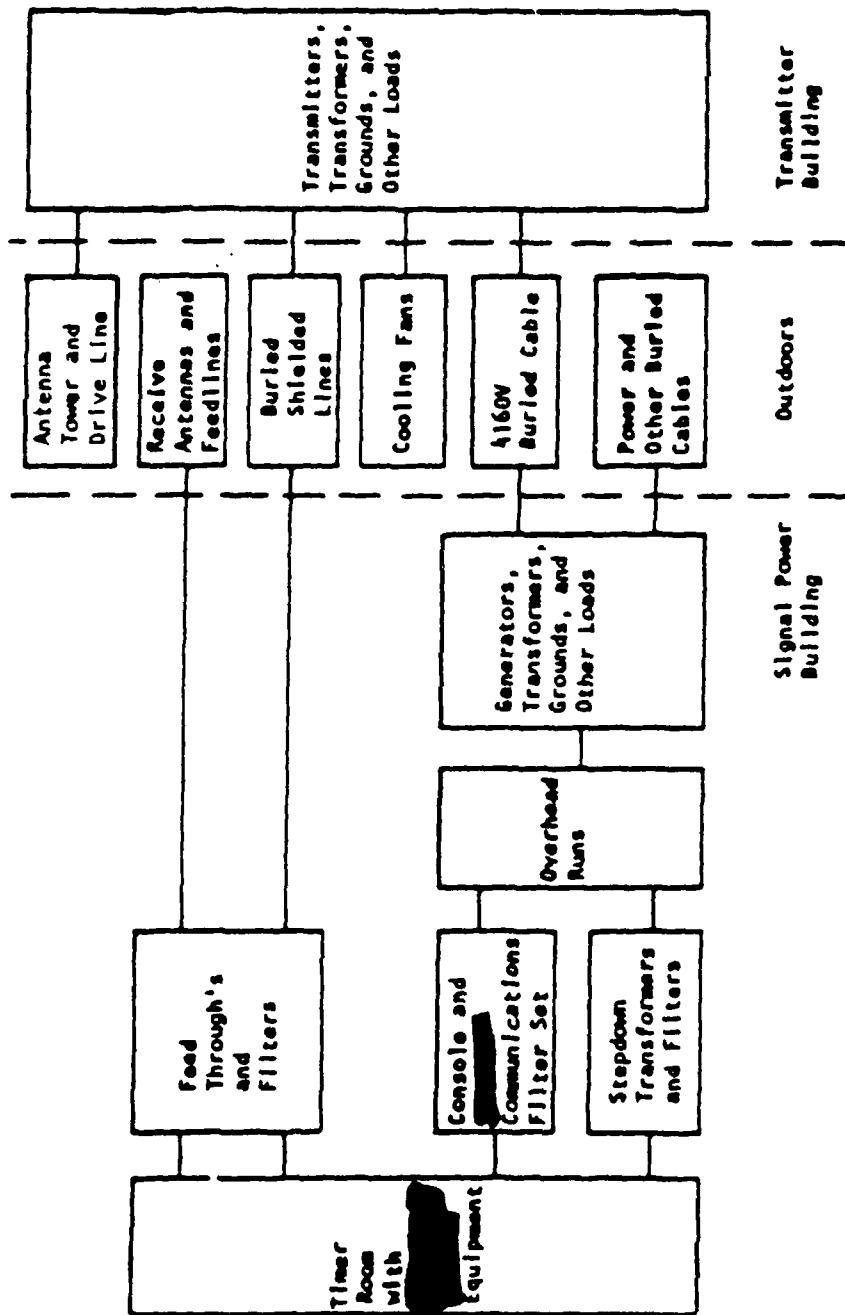

Figure C.1-1. Major penetrations and coupling paths diagram.

[REDACTED]

## C.2 PENETRATIONS

### C.2.1 Transmitter Building

The transmitter building is penetrated by various signal lines which enter near the [REDACTED] end of the building. These include shielded coax, twinax, and alarm cables coming from the signal power building.

AC power comes from the 4160 V transformers in the S-P building via a buried cable to cutouts inside the transmitter building, then to transformers and to the main power panel in the building.

The [REDACTED] transmitter tower drive line constitutes a minor penetration. Over-voltage protection of the tower and the high voltage capability of the transmitter output stage should prevent damage from this penetration.

### C.2.2 Signal-Power Building

The signal-power building is penetrated by most of the above conductors and by others. The communications lines enter near the east corner of the building and run to the timer room boxes via a floor trench and a duct on the side of the timer room.

Outside the building the transmitter drive waveform lines run in two inch diameter, hollow copper pipe to the transmitters. The pipe is open circuited at the S-P building wall. Nearby are the isolation/stepdown transformer and ac power filters. Power is supplied from the main switchboard by overhead plastic conduits ending above the timer room wall. The power conductors run free down to a duct leading to the isolation transformer.

A buried 4160 V power line runs from the transformers in the power room to transformers in the transmitter building. This is a major penetration of both buildings.

[REDACTED]

Lesser penetrations include buried power and communication lines from the S-P building to the barracks, utility buildings, communication antennas, etc.

Of still less significance are buried water, sewer, and oil lines and sound powered telephone lines. These do not couple to critical equipment or important connecting lines, except to provide additional grounding for equipment already grounded by other lines.

### C.2.3 Timer Room

The [REDACTED] gear is located in the timer room in the signal-power building. Inside the timer room, penetrating fields are low because of the electromagnetic field shielding by the signal-power building and by the timer room walls. Measured attenuation was about [REDACTED]

All significant penetrations of the timer room enter through three boxes and the ac power filters near the east corner of the timer room. The boxes are a feed-through box for coax and twinax shielded lines, a filter box for lines from the transmitter, and a [REDACTED] communications filter set for communication lines from the nearby communications console.

## C.3 COUPLING PATHS

### C.3.1 Antenna Feeds and Radios

The shielded loop antenna on the roof of the S-P building feed the [REDACTED] gear in the timer room by shielded lines. The antenna loop areas are approximately  $0.5 \text{ m}^2$ , thus coupling to the external EMP environment and conducting a large signal down the shielded antenna feed lines. The short run and small through-braid coupling coefficient ensure that EMP transients penetrating the braid are negligible compared to those coming from the antennas.

[REDACTED]

The same holds true for the parabolic array feed line. This antenna will couple a large EMP transient and propagate it down the feed line to the timer room feed through box and then to the HF radios.

The parabolic array feed line runs to a filter before entering the radios. The vulnerability to damage of this filter is comparable to that of the HF radios themselves; thus, EMP transients have been computed at the input to this filter.

The LF radios are fed directly from loop antennas on the roof. [REDACTED] Channels 6 and 7 are fed from the [REDACTED] loop on the roof. The active elements of the loop antenna will provide some buffering for the [REDACTED] receiver.

#### C.3.2 AC Power Lines

The ac power system is relatively exposed to EMP transients. The supply lines for the timer room isolation/stepdown transformer are not shielded as mentioned in Section C.2.2.

The status and control cables are shielded and through-braid coupling will be small. Thus transients are predicted to be low. The transmitter drive waveform lines, in addition, are protected by a 2-inch diameter, hollow copper pipe, which is well-grounded at the transmitter end, although open at the signal-power building end.

Two small cables bypass the filters in the [REDACTED] communications filter set and continue on into the timer room. Measurements at [REDACTED] indicate that such bypassing lines do not create significant transients inside the timer room.

#### C.3.3 Equipment Not Assessed

Many parts of the [REDACTED] gear in the timer room and parts of the transmitters have not been included in the assessment because the timer room and the van-type housing of the transmitters should provide good shielding against EMP. Consequently, only the sensitive components most directly interfacing with the penetrating lines have been treated.

[REDACTED]

In particular, the equipment in the three [REDACTED] cabinets receive ac power through a separate filter in the timer room. The timer, [REDACTED] and transmitter control set, [REDACTED] are protected against ac transients by a separate isolation transformer. The cesium beam clocks are buffered by the Elgard power supplies. Thresholds and EMP transients have been computed at the input to each of these buffering elements.

[REDACTED]

APPENDIX D  
EMP ASSESSMENT PREDICTIONS

D.1 GENERAL

A scenario variant (SV) assessment technique was used for assessing the effects of EMP on [REDACTED] facility. Using the SV technique provides for making element assessments, and developing hardness concept design packages to provide a desired survival confidence level, for the most severe high-altitude nuclear burst EMP environment.

The SV technique uses the nuclear environment parameters for a set of 17 burst locations to define the most severe response for each critical equipment item. Several bursts are required since the various power, signal, and control equipments will not all be maximally stressed by any one burst location. The uncertainty involved with using only 17 bursts does not seriously degrade determining the survival confidence of the facility. A detailed description and theoretical background of the SV technique is described in TN-52, "A Scenario Independent Technique for Assessing EMP Effects on Communication Facilities." The results of the facility assessment presented in this report consist of the most severe response for each critical circuit as produced by one of the 17 scenarios.

D.2 SCENARIO VARIANT ASSESSMENT DATA

The scenario variant assessment predictions for the critical equipment items are provided in Table D.2-1. For each critical equipment item, the largest predicted peak voltage and associated pulse frequency are provided, as are the upset and damage thresholds. Table D.2-1 also provides the safety margin and survival confidence values for each critical equipment item. The safety margin and survival confidence predictions each depend upon the predicted peak voltage. Since the SV assessment technique defines the maximum potential EMP-induced peak voltage at the critical equipment interface, the predicted safety margin and survival confidence values are the minimum levels expected for any high-altitude nuclear EMP environment condition.

[REDACTED]

[REDACTED]

The predicted safety margin is the ratio, in dB, between the threshold voltage and the predicted peak voltage. The survival confidence values were determined using the predicted safety margins and the data quality distribution which characterizes the statistical uncertainties in safety margin predictions. For the calculations used for this assessment, the data quality distribution was chosen as normally distributed with a zero mean and a standard deviation of 8 dB. This distribution was used since it is the data quality indicated from previous test experience.

APPENDIX E

BONDING\* AND ASSEMBLY INSTRUCTIONS

E.1 BONDING

Bonding refers to the process by which a low impedance path for the flow of an electric current is established between two metallic objects.

E.1.1 Surface Platings or Treatments

Surface treatments, to include platings provided for added wearability or corrosion protection, shall offer high conductivity. Plating materials shall be electrochemically compatible with the base metals. Unless suitably protected from the atmosphere, silver and other easily tarnished metals shall not be used to plate the bond surfaces.

E.1.2 Bond Protection

All bonds shall be suitably protected against weather, corrosive atmospheres, vibrations and mechanical damage. Under dry conditions a corrosion preventive or sealant shall be applied within 24 hours of assembly of the bond materials. Under highly humid conditions, sealing of the bond shall be accomplished within one hour of joining.

E.1.3 Corrosion Protection

Each bonded joint shall be protected against corrosion by assuring that the metals to be bonded are galvanically compatible in accordance with DCA Notice 310-70-1\*\*. Bonds shall be painted with a moisture proof paint conforming to the requirements of FED-STD T-TP-1757 or shall be sealed with a silicone or petroleum-based sealant to prevent moisture from reaching the bond area. Bonds

\* taken from MIL-STD-188-124

\*\*DCA Notice 310-70-1 will be replaced by MIL-HDBK-419 upon release of 419.

[REDACTED]

which are located in areas not reasonably accessible for maintenance shall be sealed with permanent waterproof compounds.

#### E.1.4 Vibration

Bonds shall be protected from vibration-induced deterioration by assuring that bolts and screws are torqued in accordance with DCA Notice 310-70-1.

#### E.1.5 Bonding Straps

Bonding straps installed across shock mounts or other suspension or support devices shall not impede the performance of the mounting device. They shall be capable of withstanding the anticipated motion and vibrational requirements without suffering metal fatigue or other means of failure. Extra care shall be utilized in the attachment of the ends of bonding straps to prevent arcing or other means of electrical noise generation with movement of the strap.

#### E.1.6 Bond Resistance

All bonds for ground conductors whose primary function is to provide a path for power, control, or signal currents shall have a maximum dc resistance of one milliohm. The resistance across joints or seams in metallic members required to provide electromagnetic shielding shall be one milliohm or less.

#### E.1.7 Clamps

Bonding clamps shall conform to AN 735 or AN 742.

#### E.1.8 Nuts, Bolts, and Washers

Nuts and bolts shall be capable of meeting the torque requirements of DCA Notice 310-70-1. Flat washers shall not be surface treated; they shall be protected as specified in paragraph E.1.18 and E.1.19 for corrosion control purposes. Star washers smaller than 1.2 cm (1/2 inch) shall not be used.

E.1.9 Direct Bond

Wherever possible, bonding of metallic or other conductive members shall be accomplished by direct contact of the mating surface with the electrical path achieved by a welded, brazed, soldered, or high-compression bolted connection.

E.1.10 Welding

Permanent connections between ferrous materials shall be welded whenever possible.

E.1.11 Brazing and Silver Soldering

Brazing or silver soldering is acceptable for the permanent bonding of copper and copper alloy materials.

E.1.12 Bonding of Copper to Steel

Either brazing or exothermic welding shall be used for the permanent bonding of copper conductors to steel or other ferrous structural members.

E.1.13 Soft Soldering

Soft soldering shall not be used for bonding purposes.

E.1.14 Sweat Soldering

Sweat soldering shall be used for electrical bonding only when other fasteners such as bolts or rivets are concurrently used to provide mechanical strength.

[REDACTED]

E.1.15 Bolting

All bonds utilizing bolts and other threaded fasteners shall conform to the minimum torque requirements given in DCA Notice 310-70-1. Inspection shall be conducted periodically. Before joining, all faying surfaces shall be prepared per paragraph E.1.10. Particular care shall be taken to provide adequate corrosion protection to all electrical bonds made with bolts and other threaded fasteners.

E.1.16 C-Clamps and Spring Clamps

C-clamps and spring clamps shall not be used for permanent or semi-permanent bonding.

E.1.17 Indirect Bonds

Where the direct joining of structural elements, equipments, and electrical paths is impossible or impractical to achieve, bonding straps or jumpers shall be used.

E.1.18 Surface Preparation

All mating surfaces which comprise the bond shall be thoroughly cleaned before joining to remove dust, grease, oil, moisture, nonconductive protective finishes, and corrosion products.

- 1) Area to be Cleaned. All bonding surfaces shall be cleaned over an area that extends at least .5 cm (1/4 in.) beyond all sides of the bonded area on the larger member.
- 2) Paint Removal. Paints, primers, and other organic finishes shall be removed from the metal.
- 3) Inorganic Film Removal. Rust, oxides, and nonconductive surface finishes such as anodize shall be removed.

- [REDACTED]
- 4) Final Cleaning. After initial cleaning with chemical paint removers or mechanical abrasives, the bare metal shall be wiped or brushed with dry cleaning solvent meeting the requirements of Federal Specifications P-D-580. Surfaces not requiring the use of mechanical abrasives or chemical paint removers shall be cleaned with a dry cleaning solvent to remove grease, oil, corrosion preventives, dust, dirt, and moisture prior to bonding.
  - 5) Clad Metals. Clad metals shall be cleaned with fine steel wool or grit in such a manner that the cladding material is not penetrated by the cleaning process. A bright, smooth surface shall be achieved. The cleaned area shall be wiped with dry cleaning solvent and allowed to air dry before completing the bond.
  - 6) Aluminum Alloy. After cleaning of aluminum surfaces to a bright finish, a brush coating of iridite or other similar conductive finishes shall be applied to the mating surfaces.
  - 7) Completion of the Bond. If an intentional protective coating is removed from the metal surface, the mating surfaces shall be joined within 30 minutes after cleaning.

#### E.1.19 Dissimilar Metals

All mating surface materials that comprise a bond shall be identified. Compression bonding with the use of bolts or clamps shall be utilized only between metals having acceptable coupling values as indicated in DCA Notice 310-70-1. When the base metals form couples that are not allowed, the metals shall be plated, coated, or otherwise protected with a conductive finish, or a material compatible with each shall be inserted between the two base metals. It shall be constructed from or plated with an appropriate intermediate metal.

E.1.2 Corrosion Prevention (Below Grade)

Because of galvanic corrosion between dissimilar metals, below grade and/or high moisture areas, the welded or brazed joint shall be covered with pitch or other suitable waterproof compound to inhibit corrosion.

E.2 ASSEMBLY

The following subparagraphs deal with special installations peculiar to hardness concept designs.

E.2.1 Rigid Conduit, Threaded Connections

Rigid conduit (new or old installations) used for shielding or rf returns shall be assembled as follows:

- 1) Cleaning. All mating surfaces for threaded connections shall be prepared as in paragraph E.1.18.
- 2) Assembly. Apply cold galvanizing compound\* "Galvicon" to thread parts and assemble wet. Wipe off excess and let joint dry.
- 3) Corrosion Protection. Protect the connection as in paragraph E.1.3.

E.2.2 Rigid Conduit, Box or Cabinet Connection

Rigid conduit (new or old installations) used for shielding or rf returns shall be assembled as follows:

- 1) Cleaning. All faying surfaces shall be prepared as in paragraph E.1.18.

\* Kenco Division  
Southern Coatings and Chemical Co., Inc.  
Sumter, South Carolina 29150

- [REDACTED]
- 2) Assembly. Assemble using a rigid conduit metallic bushing and bonding type lock nut.
  - 3) Corrosion Protection. Protect the connection as in paragraph E.1.3.

E.2.3 Coaxial Cable, Severe Environment

Coaxial cable connections exposed to outdoor environments or high humidity shall be assembled as follows:

- 1) Cleaning. All metal surfaces shall be prepared as in paragraph E.1.18.
- 2) Assembly. Assemble connectors and clean as in paragraph E.1.18.
- 3) Corrosion Protection. Apply Dow Corning\*\* 3145 RTV adhesive/sealant (non-corrosive) on the connector forming a seal to preclude migration of water or vapor down the cable or at the threaded portion of the connector.

E.2.4 Coaxial and Shielded Cable, Intermediate Point Bonding

Cables requiring attachment of ground strap at points other than cable ends shall be prepared as follows:

- 1) Cleaning. Remove at least 3 cable diameters of the protective sheath to expose the cable shield. Prepare the shield surfaces as in paragraph E.1.18 except that any solvents used for cleaning shall be compatible with the cable dielectric and the insulating material.

\*\* Dow Corning Corporation  
Midland, Michigan 48640

[REDACTED]

2) Assembly. Shield bonding is achieved by using a cable clamp to which a flat bonding strap is attached. To avoid crushing the cable dielectric and insulating material, fabricate a pressure sleeve which will be installed under the bonding clamp to distribute clamping pressure over a larger area. The pressure sleeve should be flared on each end, split to facilitate assembly and have a length of about 2 cable diameters. Thin wall copper tubing slightly smaller than the cable diameter should be used and tinned both inside and out with a 50/50 solder using a non-corrosive flux. Install the sleeve and an AN735 type bonding clamp. Prepare a bonding strap of tinned copper flat braid of the largest size possible that is compatible with the terminal lug size determined by the required pressure clamp size. The bonding strap should not be more than 6 inches long and shorter if possible. Crimp and solder a lug to each end of the flat braid. Clean the metal parts as in paragraph i) above and assemble the sleeve, clamp and bonding strap terminal to the cable. Tighten the clamp, but not so tight as to crush the dielectric or wire insulation. Fasten the other end of the bond strap to the ground plane in accordance to the bonding instructions in paragraph E.1.

3) Corrosion Protection. Apply Dow Corning\*\* 3145 RTV adhesive/sealant (non-corrosive) to the cable, sleeve and bonding clamp. Completely cover the bond assembly, overlapping the protective sheath on the cable and the terminal lug on the clamp. Thus, forming a seal to preclude migration of water or vapor down the cable.

\*\* Dow Corning Corporation  
Midland, Michigan 48910