

3

USAFSAM-TR-88-15

AD-A206 905

WAVELENGTH-DEPENDENT AND - INDEPENDENT EFFECTS OF VEILING GLARE ON THE VISIBILITY OF HEAD-UP DISPLAY (HUD) SYMBOLOGY

Denise C. Varner, Ph.D.
Robert M. Cartledge, Lt Col, USAF, BSC (USAFSAM/RZV)
W. Rowe Elliott, III, B.S.
Arthur R. Menendez, Ph.D. (USAFSAM/RZV)
Roxie Carrier, M.S.
Marta J. Richter, B.S.

KRUG International
Technology Services Division
406 Breesport
San Antonio, TX 78216

September 1988

DTIC
ELECTE
APR 18 1989
S E D

Final Report for Period September 1986 - January 1988

Approved for public release; distribution is unlimited.

Prepared for
USAF SCHOOL OF AEROSPACE MEDICINE
Human Systems Division (AFSC)
Brooks Air Force Base, TX 78235-5301



NOTICES

This final report was submitted by KRUG International, Technology Services Division, 406 Breesport, San Antonio, Texas, under contract F33615-84-C-0600, job order 7757-02-82, with the USAF School of Aerospace Medicine, Human Systems Division, AFSC, Brooks Air Force Base, Texas. Lt Col Robert M. Cartledge (USAFSAM/RZV) was the Laboratory Project Scientist-in-Charge.

When Government drawings, specifications, or other data are used for any purpose other than in connection with a definitely Government-related procurement, the United States Government incurs no responsibility or any obligation whatsoever. The fact that the Government may have formulated or in any way supplied the said drawings, specifications, or other data, is not to be regarded by implication, or otherwise in any manner construed, as licensing the holder or any other person or corporation; or as conveying any rights or permission to manufacture, use, or sell any patented invention that may in any way be related thereto.

The voluntary fully informed consent of the subjects used in this research was obtained in accordance with AFR 169-3.

The Office of Public Affairs has reviewed this report, and it is releasable to the National Technical Information Service, where it will be available to the general public, including foreign nationals.

This report has been reviewed and is approved for publication.

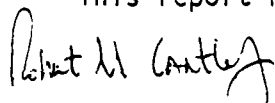

ROBERT M. CARTLEDGE, Lt Col, USAF, BSC
Project Scientist



DONALD N. FARRER, Ph.D.
Supervisor

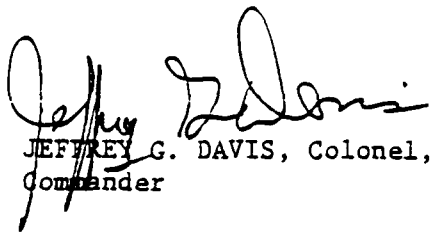

JEFFREY G. DAVIS, Colonel, USAF, MC
Commander

UNCLASSIFIED

SECURITY CLASSIFICATION OF THIS PAGE

REPORT DOCUMENTATION PAGE				Form Approved OMB No 0704-0188	
1a. REPORT SECURITY CLASSIFICATION Unclassified			1b. RESTRICTIVE MARKINGS		
2a. SECURITY CLASSIFICATION AUTHORITY			3. DISTRIBUTION/AVAILABILITY OF REPORT Approved for public release; distribution is unlimited.		
2b. DECLASSIFICATION/DOWNGRADING SCHEDULE			4. PERFORMING ORGANIZATION REPORT NUMBER(S)		
4. PERFORMING ORGANIZATION REPORT NUMBER(S)			5. MONITORING ORGANIZATION REPORT NUMBER(S) USAFSAM-TR-88-15		
6a. NAME OF PERFORMING ORGANIZATION KRUG International Technology Services Division		6b. OFFICE SYMBOL (if applicable)	7a. NAME OF MONITORING ORGANIZATION USAF School of Aerospace Medicine (RZV)		
6c. ADDRESS (City, State, and ZIP Code) 406 Breesport San Antonio, TX 78216		7b. ADDRESS (City, State, and ZIP Code) Human Systems Division (AFSC) Brooks Air Force Base, TX 78235-5301			
8a. NAME OF FUNDING/SPONSORING ORGANIZATION		8b. OFFICE SYMBOL (if applicable)	9. PROCUREMENT INSTRUMENT IDENTIFICATION NUMBER F33615-84-C-0600		
8c. ADDRESS (City, State, and ZIP Code)		10. SOURCE OF FUNDING NUMBERS			
		PROGRAM ELEMENT NO 62202F	PROJECT NO 7757	TASK NO 02	WORK UNIT ACCESSION NO 82
11. TITLE (Include Security Classification) Wavelength-Dependent and -Independent Effects of Veiling Glare on the Visibility of Head-Up Display (HUD) Symbology					
12. PERSONAL AUTHOR(S) Varner, Denise C.; Cartledge, Robert M. (USAFSAM/RZV); Elliott, W. Rowe III; Menendez, Arthur R. (USAFSAM/RZV); Carrier, Roxie; and Richter, Marta J					
13a. TYPE OF REPORT Final		13b. TIME COVERED FROM 86/09 TO 88/01	13c. DATE OF REPORT (Year, month, Day) 1988, September		13d. PAGE COUNT 25
16. SUPPLEMENTARY NOTATION					
17. COSATI CODES			18. SUBJECT TERMS (Continue on reverse if necessary and identify by block number)		
FIELD	GROUP	SUB-GROUP	Age effects; Chromatic sensitivity; Glare; Head-up display; Illuminance; Laser bioeffects; Visibility; Visual perception; Visual sensitivity; Wavelength dependence		
20	06				
06	04				
19. ABSTRACT (Continue on reverse if necessary and identify by block number) We have measured the effects of laser glare-source wavelength on the visibility of Head-Up Display (HUD) symbology. Most of the effects are due to the wavelength dependence of human illuminance sensitivity. When the human visibility function is taken into account, the magnitude of the wavelength dependence is reduced by a factor of 4.2. A second effect is a wavelength-independent effect in subjects. This second effect is directly correlated with subject age. The remaining (small) variation may be due to chromatic contrast sensitivity.					
20. DISTRIBUTION/AVAILABILITY OF ABSTRACT <input checked="" type="checkbox"/> UNCLASSIFIED/UNLIMITED <input type="checkbox"/> SAME AS RPT <input type="checkbox"/> OTIC USERS			21. ABSTRACT SECURITY CLASSIFICATION Unclassified		
22a. NAME OF RESPONSIBLE INDIVIDUAL Robert M. Cartledge, Lt Col, USAF, BSC		22b. TELEPHONE (include Area Code) (512) 536-3622		22c. OFFICE SYMBOL USAFSAM/RZV	

DD Form 1473, JUN 86

Previous editions are obsolete.

SECURITY CLASSIFICATION OF THIS PAGE

UNCLASSIFIED

SUMMARY

1. HUD symbology may be obscured by low power CW lasers when the line of sight to the laser is the same as the line of sight to the symbology.

2. There is a wavelength dependence for radiometric thresholds with minimum thresholds in the green and maximum thresholds in the red (sensitivity relations are inverse with threshold). The ratio of this difference can be as high as 50 to 1; it averages 19 to 1.

3. When the inherent luminous efficiency of lights of different wavelengths are factored out, the ratio of threshold differences is reduced to an average factor of 4.5.

4. There are large individual differences in sensitivity, but most of these differences are independent of wavelength.

5. The cause of the wavelength-independent variability is not known, but there is some evidence that it is directly related to subject age.

6. The majority of the subjects show a small purely chromatic effect. The magnitude of the effect is much less than would be due either to luminance or to subjects. Consequently, any modeling effort must examine the among-subjects wavelength-independent variance.



Accession For	
NTIS GRA&I	<input checked="" type="checkbox"/>
DTIC TAB	<input type="checkbox"/>
Unannounced	<input type="checkbox"/>
Justification	
By	
Distribution/	
Availability Codes	
Dist	Avail and/or Special
A-1	

TABLE OF CONTENTS

	<u>Page</u>
SUMMARY	iii
OBJECTIVE AND BACKGROUND	1
METHODS	2
Subjects	2
Apparatus	2
Calibrations	2
Procedure	6
RESULTS AND DISCUSSION	8
REFERENCES	17

Figures

<u>Fig. No.</u>		
1.	Experimental apparatus	3
2.	Contour map of irradiance in the plane of the subject's pupil	5
3.	HUD symbology	6
4.	Spectral emission of HUD phosphor measured by Pritchard Model 1980 B spectroradiometer	7
5.	Logarithm of sensitivity to glare as a function of wavelength	9
6.	Illuminance of glare source necessary to obscure HUD as a function of wavelength	10
7.	Normalized illuminance data	13
8.	Illustration of relative magnitudes of errors due to averaging among subjects	15
9.	Illustration of relative magnitudes of errors due to averaging among wavelengths and errors due to averaging among subjects	16

CONTENTS (Cont'd.)

Tables

<u>Table No.</u>		<u>Page</u>
1.	Stimulus conditions	4
2.	Obscuration thresholds (log irradiance -- log W/cm ²)	8
3.	Reduction in range of threshold variation across wavelength by converting from irradiance to illuminance	11

WAVELENGTH-DEPENDENT AND -INDEPENDENT EFFECTS OF VEILING GLARE ON THE VISIBILITY OF HEAD-UP DISPLAY (HUD) SYMBOLOGY

OBJECTIVE AND BACKGROUND

Among the many external hazards and stressors that military pilots may encounter are high intensity laser beams. Pulsed lasers produce intense, very brief bursts of laser radiation that can cause temporary flashblindness and ocular damage, including retinal lesions (1-5). Continuous-wave (CW) lasers, on the other hand, emit lower energy radiation, but can nevertheless produce substantial visual effects. At long range, CW lasers could create significant glare that could obscure the aircraft instruments from the pilot's vision and interfere with the mission. The purpose of this study is to investigate one aspect of glare produced by lasers under conditions similar to a pilot's operating environment.

One key factor in the analysis of glare is the point-spread function (PSF) of the human eye. Every optical system has a characteristic PSF which indicates the way that the system spreads out the light from an ideal point source. In the case of the human eye, the PSF may be generalized to include not only intraocular scatter but also spatial vision effects resulting in what may be called a "glare-spread" function (GSF) (6). These functions may be used to predict visual sensitivity to any target by means of the convolution theorem (7) and the equivalent background assumption (8). Lasers are highly monochromatic point sources. If the GSF depends on wavelength, then glare from laser sources will vary in effectiveness with wavelength.

A recent report has determined that the scattering of light within the eye does not depend on wavelength (9). The authors of this study used spatially extended sources rather than point sources but, nevertheless, their results imply that the GSF may not vary with source wavelength. Intraocular scatter is not, however, the only possible influence of the wavelength of a glare source. Different wavelength sources of equal energy, nevertheless, have different visual effects because of the eye's differential sensitivity to lights of different wavelengths; equal energy lights of different wavelengths may not appear equally bright. Lights can be made equal in visual efficiency by equating them for illuminance, a photometric measure that is corrected by the standard human visual efficiency curve known as V_λ . Equating glare sources in this way could reduce any apparent wavelength dependence (10).

Even if glare sources are equated photometrically, wavelength-dependent effects may still occur. Illuminance-equated lights may differ in chromatic contrast, and targets may be detected by mechanisms sensitive to chromatic contrast (11-13). In fact, small color effects have been reported recently for some electrophysiological measures following laser flashes (14,15). Some of these effects have been attributed to the activity of opponent-color mechanisms (15,16). These mechanisms could play a role for glare sources as well as for flashed sources.

The experimental questions raised here are simple: is the effectiveness of laser-induced glare wavelength dependent and, if so, is the wavelength dependence due to visual chromatic mechanism sensitivity? We examined these questions by measuring the visibility of colored targets in the presence of eye-safe, laser-induced glare.

METHODS

Subjects

Subject participation was governed by AFR 169-3, USAFSAM Human Use Protocol 86-18, and Addendum. Six volunteer human subjects were tested. Five subjects were male, and one was female. Their ages ranged from 27 to 47 with a mean age of 37.2 years. Five had normal uncorrected acuity at distance, and one was a slight myope corrected to 6/6 acuity. All subjects were given complete ophthalmological examinations before the experiment. They were reevaluated after the experiment and found to be unchanged from the pre-experimental examination.

Apparatus

Figure 1 shows the main components of the experimental apparatus. A frame apparatus was constructed as a cockpit mockup. It was covered by a scratched F-16 canopy that was removed from the inventory. A pre-production F-16AB HUD manufactured by General Dynamics was placed within the frame in the proper relation to the canopy. Experimental subjects were seated on an adjustable aircraft seat (A-7A) so that their heads were at the design eye position of the HUD. In this position, the subjects looked through the HUD and saw its symbology superimposed on the center of the field of view.

The subjects were required to resolve a symbol displayed at optical infinity on the HUD. A glare source was produced by routing laser light through a fiber-optic cable (Fig. 1). The fiber-optic cable removed the beam collimation and spread the beam to about a 30-deg angle. The output of the fiber-optic cable subtended less than a minute of arc; consequently, its image (and hence, the image of the glare source) was limited by the GSF of the eye. The subjects sat about 3 m from the output of the optical fiber. Two lasers (Coherent Krypton Innova 100 and Argon Innova 100) and five lines (488 nm and 514 nm from argon; 530 nm, 568 nm, and 647 nm from krypton) were used. Laser output was 1 W at all wavelengths. Stimulus conditions are summarized in Table 1.

Calibrations

An EG&G radiometer head was placed facing the glare source in the vertical plane passing through the design eye position; it was orthogonal to the line from design eye position to source. The radiometer head was moved systematically to several points of a rectangular array in that plane. The irradiance from the laser was measured at each position, producing a point-by-point mapping of the beam distribution. The beam profile was measured with and without the cockpit mockup. In the absence of the canopy and the

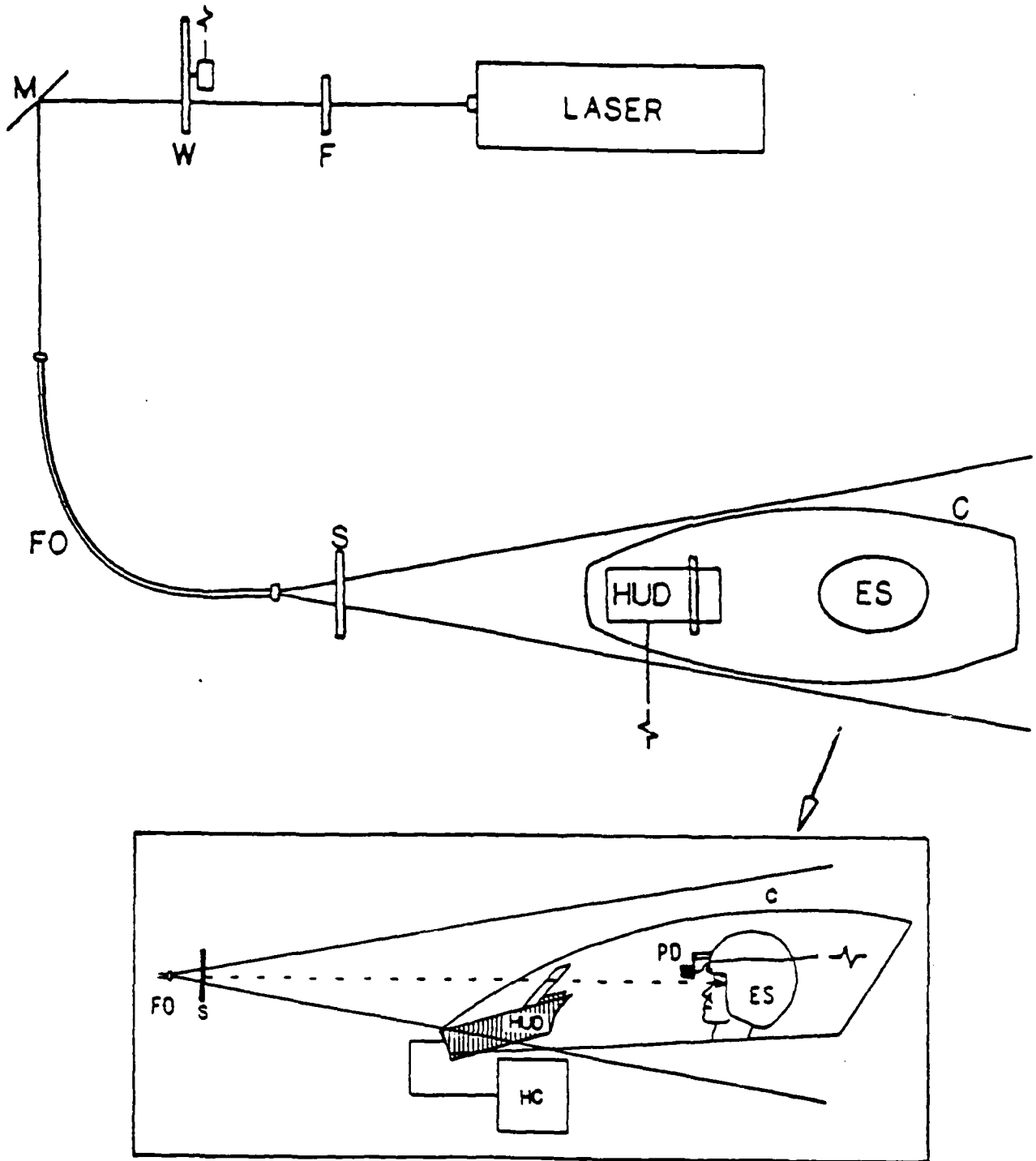

- | | | | |
|-----|--------------------------|-------|--|
| C | - F16 canopy | LASER | - Argon or krypton ion laser |
| ES | - Experimental subject | M | - Front surface mirror |
| F | - Neutral density filter | PD | - Photodiode |
| FO | - Fiber optic | S | - Shutter |
| HC | - HUD controller | W | - Motor-driven variable
neutral density wedge |
| HUD | - Head-up display | | |

Figure 1. Experimental apparatus. View is downward in top panel.

TABLE 1. STIMULUS CONDITIONS

Laser Glare Conditions	
Beamspread:	30 deg-arc
Duration:	7 s or less
Wavelengths:	488 nm 514 nm 530 nm 568 nm 647 nm
HUD	
Luminance:	175 cd/m ²
Color:	Broadband green
Symbols:	Flight path marker (FPM) and pitch ladder (PL)
FPM Size:	34 min-arc diameter and 34 min-arc wings
Stroke Width:	2 min-arc

HUD, the beam profile at the plane of the cornea was nearly Gaussian; it was about 1 m in diameter. Figure 2 plots the beam irradiance profile for the 514-nm glare source measured inside the cockpit. The canopy and HUD altered the profile slightly because of the shadow cast by the HUD support frame. The other wavelengths had similar profiles. The subject's head was positioned outside the shadow in the region indicated by the square in Figure 2. The irradiance of the Gaussian beam distribution was nearly constant over the region where a subject might move his or her head.

Laser output was regulated by its own power controller. An additional laser power meter was used to measure the emitted beam as an independent check at the beginning of each day. The peak laser intensity was carefully monitored throughout the experiment. The laser output maximum was attenuated by neutral density filters placed in front of the optical train. Specific filters were used for each wavelength so that the maximum power reaching the eye never exceeded 5% of the maximum permissible exposure (MPE) calculated for direct intrabeam viewing of intermittent exposures from a CW laser source (17). Exposure levels were recorded directly from a PIN-10 photodiode mounted on the subject's helmet. The photodiode was cross-calibrated against the EG&G radiometer.

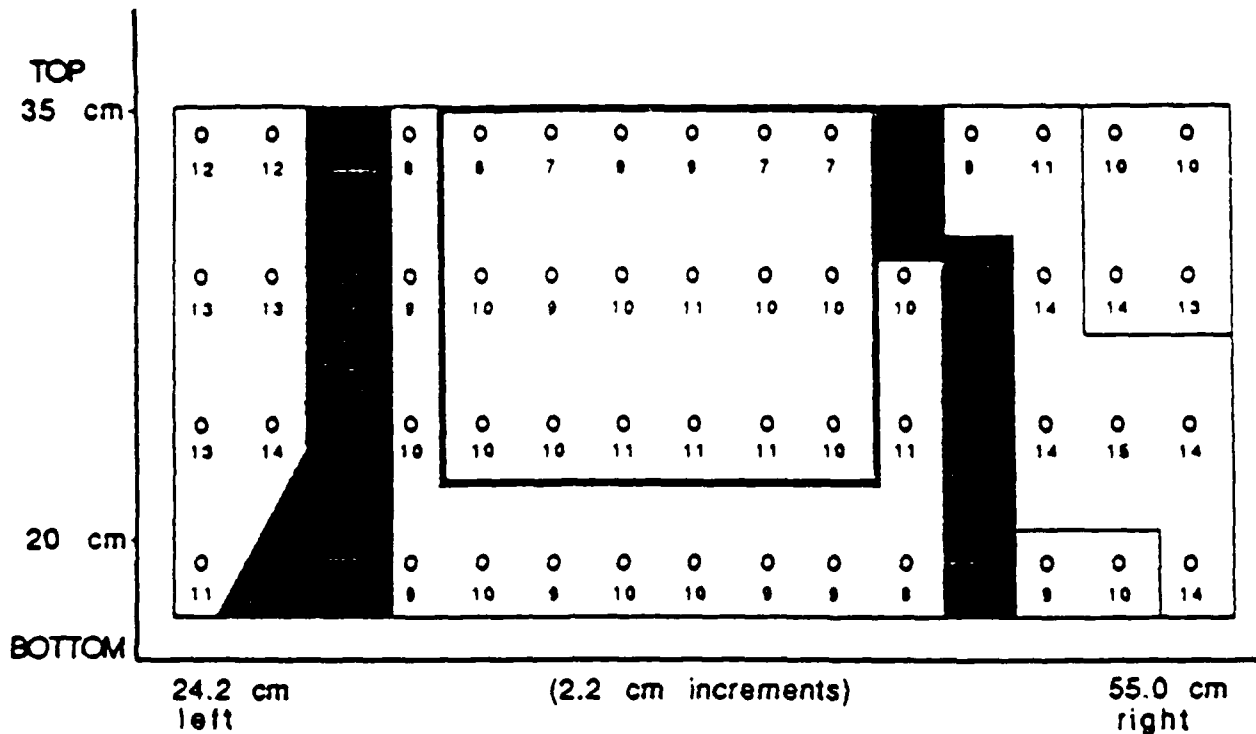

Figure 2. Contour map of irradiance in the plane of the subject's pupil. Recorded with an EG&G photometer placed at each numbered point in the array. This map is for the 488-nm line of an argon laser operating at 1 W and attenuated by the neutral density wedge in the experimental apparatus. Numbers are in $\mu\text{W}/\text{cm}^2$. The black square is the boundary for the region in which the subject's head is placed. The laser intensity is nearly uniform within this region. The black areas without numbers map out the shadow made by the HUD's combiner-glass support.

The HUD flight path marker (FPM) symbol was used as a test target (Fig. 3). The point source was imaged in the center of the FPM; light scattered (or otherwise spread away) from the source obscured the symbol. The luminance of the HUD was measured with a Pritchard Model 1980 B tele-photometer, and the measurement was checked several times during the course of the experiment. The HUD luminance was maintained at 175 cd/m². The symbol generated by the HUD broadband phosphor appeared yellow-green under otherwise dark conditions. Its spectral emission is shown in Figure 4. Its measured chromaticity was $x = 0.190$, $y = 0.719$. The stroke width of the symbol is 2 min-arc, and the diameter of the circular part of the symbol is 34 min-arc (Table 1).

Procedure

Before each experimental session, the subject adjusted the aircraft seat until the HUD FPM symbol was centered on the output end of the fiber optic as seen by the subject's preferred eye. The other eye was patched. During this procedure, the laser output was blocked. When the subject was properly positioned, the room lights were turned off, and the subject adapted to the light provided by the HUD for 2 min.

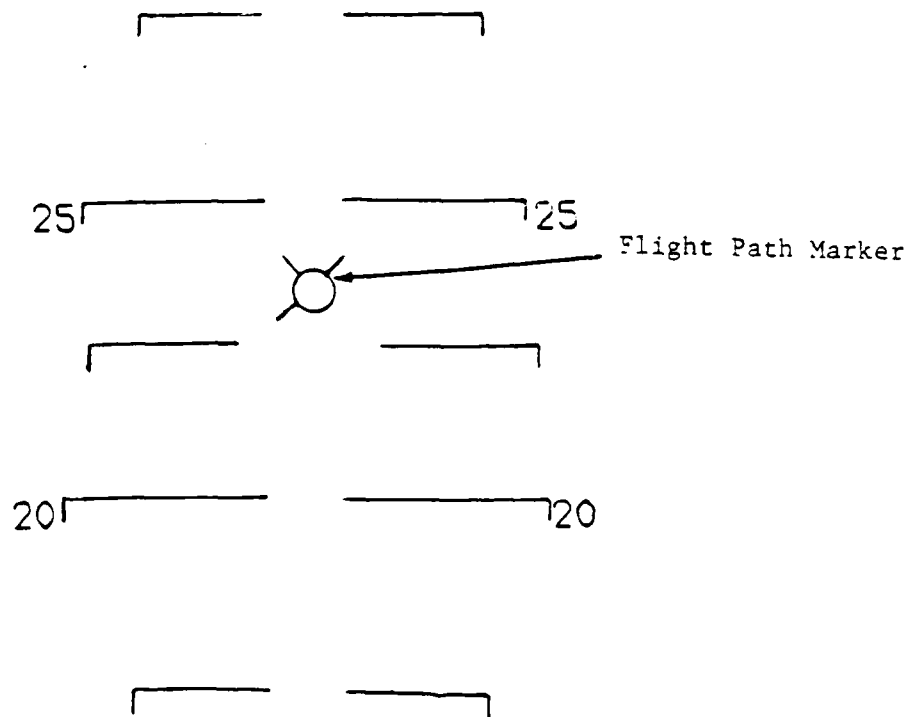

Figure 3. HUD symbology. The flight path marker is the symbol used as a test stimulus. A threshold is recorded when the FPM is just obscured by glare from the laser.

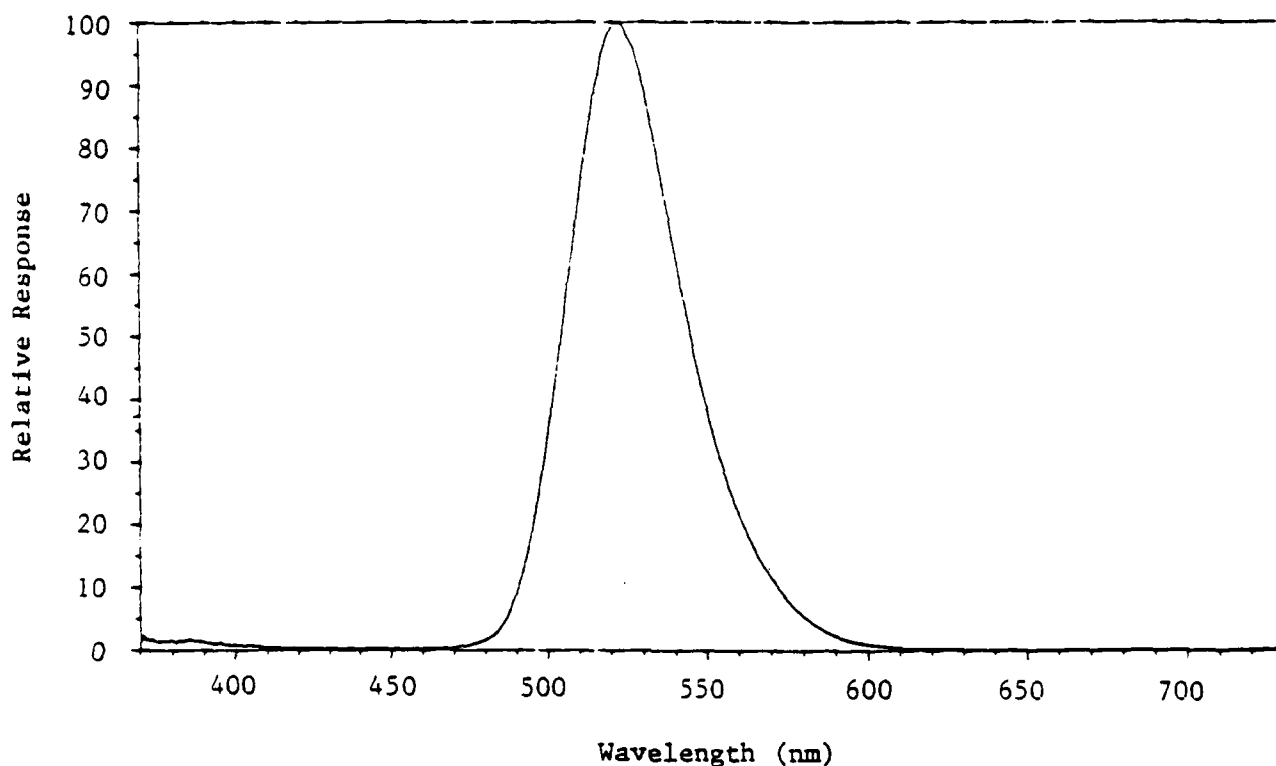

Figure 4. Spectral emission of HUD phosphor measured by Pritchard Model 1980 B spectroradiometer.

At the conclusion of the adaptation period, on the subject's signal, a trial began. The subject pressed a button on a hand-held controller that simultaneously opened a shutter (Uniblitz) and advanced a pair of counter-rotating neutral density wedges (0-2 ND total; Melles-Griot). This procedure delivered the laser light at a very low intensity; the intensity slowly increased as the neutral density wedges advanced. The exposure was terminated either when: a) the subject indicated that the HUD symbology was obscured; b) 7 s passed without a threshold determination; or c) the intensity of the exposure reached a predetermined maximum (5% of the MPE). Irradiance at the subject's eye was monitored by the photodiode on the subject's helmet. Its output was recorded by a strip-chart recorder that was later converted to irradiance using a previously measured calibration curve. Following each trial, the glare source was blocked from the subject's view and its intensity reduced below threshold. A dark period (10-40 s) occurred between each trial. Twelve threshold determinations were made in each session. There were three sessions per wavelength for every subject, but only one wavelength was tested in a single session.

RESULTS AND DISCUSSION

In Table 2, mean glare source power at the obscuration threshold is given for each subject as the logarithm of W/cm^2 for each wavelength tested along with the standard error of the mean. For every wavelength, the mean among subjects is given as well as its standard error. In Figure 5, the logarithms of sensitivity for all six subjects and their average are plotted as a function of wavelength. Sensitivity is given in units of reciprocal obscuration power per unit area ($1/\mu W/cm^2$). The solid curve in Figure 5 is the standard luminous efficiency curve V_λ .

TABLE 2. OBSCURATION THRESHOLDS (LOG IRRADIANCE -- LOG W/cm^2)

Subject	wavelength (nm)				
	488	514	530	568	647
1	-5.462480 (0.034034)	-5.583427 (0.042364)	-6.215859 (0.030000)	-5.887935 (0.032268)	-4.645525 (0.027720)
2	-5.211356 (0.029272)	-5.124006 (0.033429)	-5.457559 (0.016880)	-4.780690 (0.050932)	-4.936761 (0.020270)
3	-5.600066 (0.035302)	-5.588408 (0.028577)	-5.975262 (0.028540)	-5.731935 (0.023782)	-4.604337 (0.031192)
4	-5.812483 (0.033226)	-5.696216 (0.030039)	-6.386358 (0.022157)	-6.033620 (0.024790)	-4.692799 (0.025343)
5	-6.014896 (0.020981)	-5.974028 (0.026242)	-6.412505 (0.016313)	-5.599041 (0.015828)	-5.033408 (0.033468)
6	-5.016980 (0.040767)	-5.051444 (0.097209)	-5.596560 (0.043778)	-5.317599 (0.080885)	-4.531996 (0.065432)
Mean	-5.519710 (0.033930)	-5.502922 (0.042977)	-6.007351 (0.026278)	-5.558520 (0.038081)	-4.738887 (0.033904)

Numbers in parentheses denote the standard error of the mean.

Three factors emerge from these data. First, sensitivity is greatest in the middle of the spectrum. Second, there is an overall range of variation in excess of a decade between the wavelengths of greatest and of least sensitivity. Third, there is a very large spread of overall individual sensitivity. It will be shown that the wavelength-dependent variations can be accounted for largely by variations in the visual mechanism of luminance. It will also be shown that most of the individual differences are not wavelength dependent, but rather reflect differences in overall sensitivity (i.e., differences due to age, Weber fractions, or criterion effects). These data are the averages for each of six experimental subjects; there were three sessions per subject and twelve trials per session.

In Figure 6, the same data are plotted as a function of the logarithm of the illuminance of the veiling glare that just obscures the FPM. This measure yields an obscuration threshold (not sensitivity as in Fig. 5;

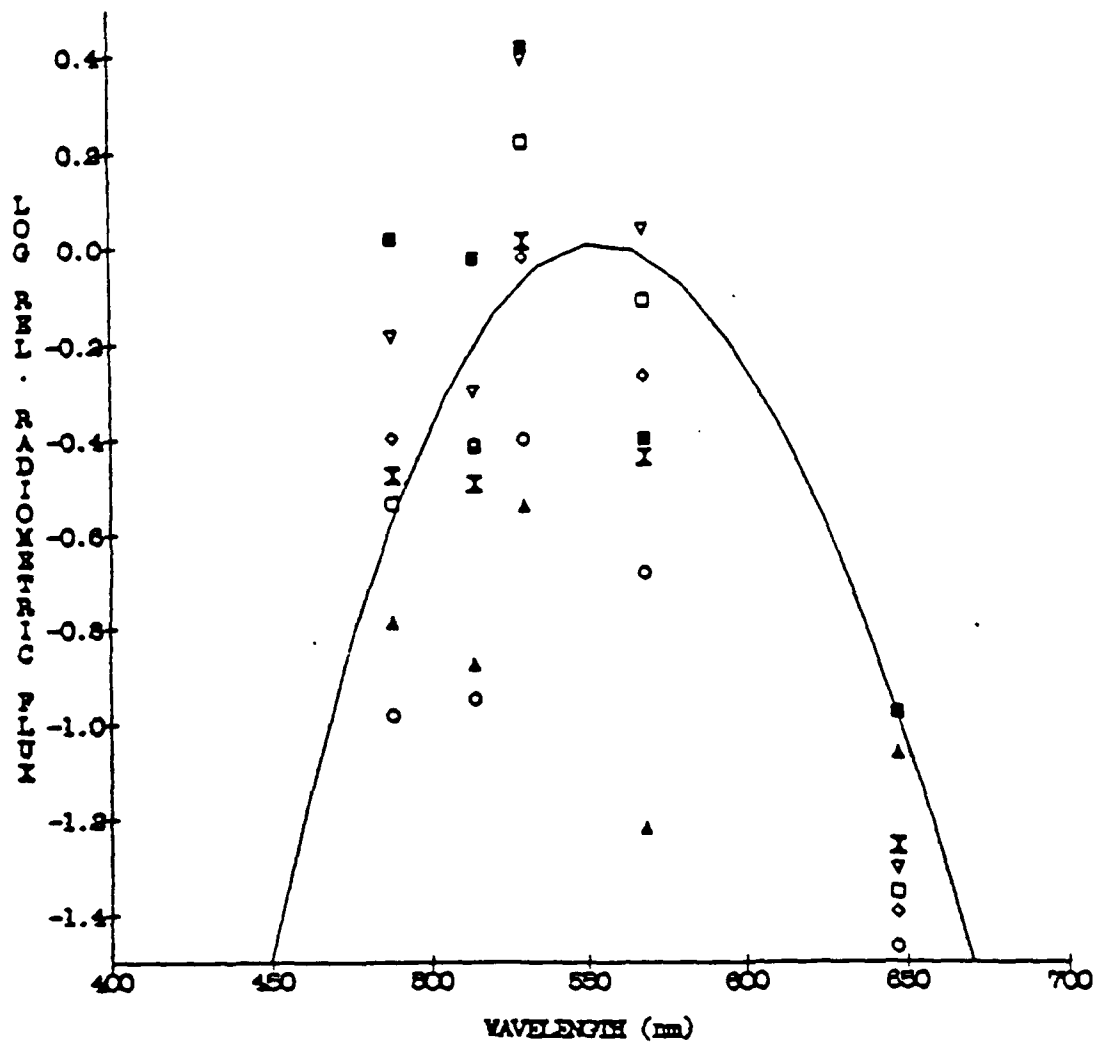

Figure 5. Logarithm of sensitivity to glare as a function of wavelength. Ordinal units are radiometric (proportional to the log of the inverse of glare source $\mu\text{W}/\text{cm}^2$ necessary to obscure the HUD). Data are plotted for six subjects and the average among subjects at each wavelength.

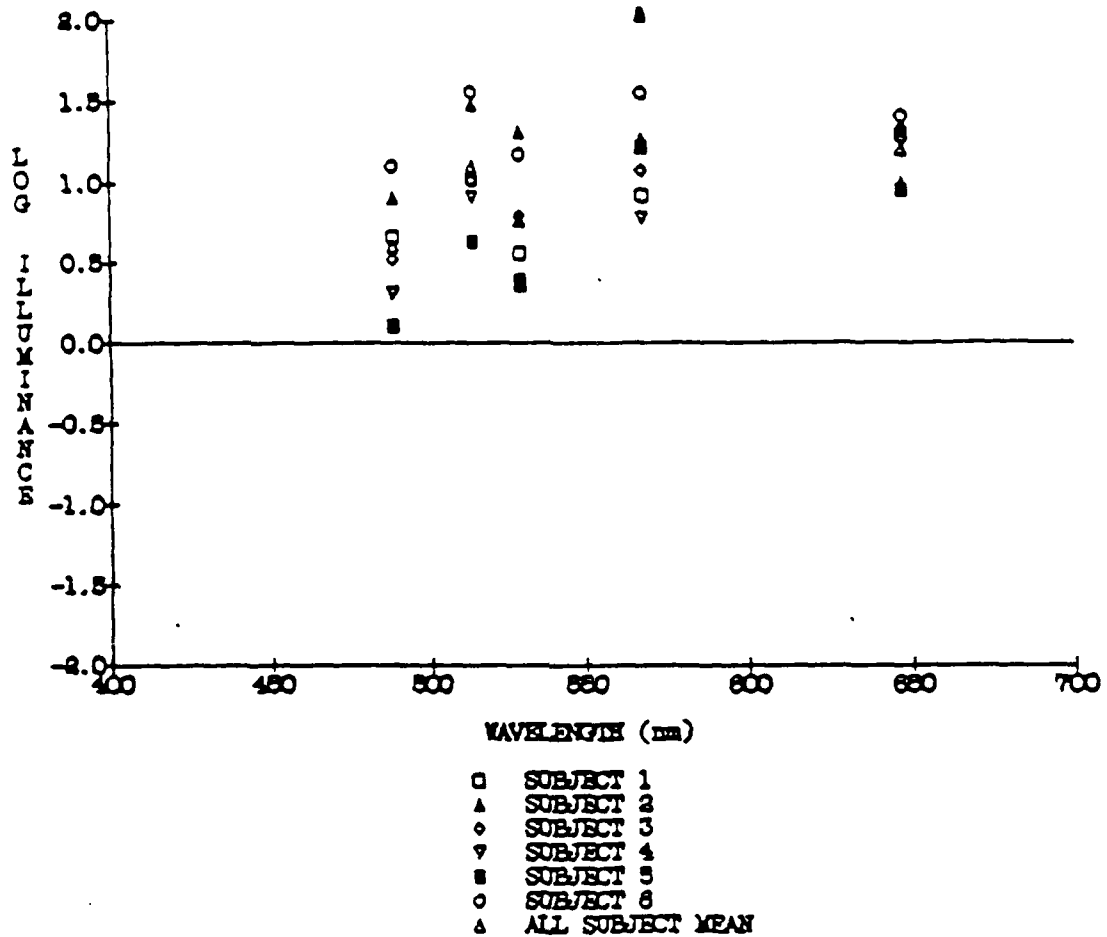

Figure 6. Illuminance of glare source necessary to obscure HUD as a function of wavelength. Ordinal units are log Lux. This curve plots obscuration threshold, not sensitivity as in Figure 5. Data are plotted for six subjects, and the average among subjects, at each wavelength.

threshold is the inverse of sensitivity). Illuminance units are indications of the visibility or brightness of a light source, rather than its energy. The luminance efficiency (V_λ) of each wavelength is included in the illuminance calculation. Transforming the data from irradiance to illuminance reveals the extent to which the variation in thresholds is a consequence of the wavelength dependence of visibility. Deviations of the data from the horizontal indicate the amount of error that would result if the variation of threshold was due only to the variation of the visibility of the source.

Replotting the data in terms of illuminance reduces the variation in thresholds over wavelength. This improvement may be seen by examining the among-subject average data. In Figure 5, the function for the average subject varies over a factor of $10^{1.27}$ (the ratio of highest ordinate value to lowest ordinate value is 19), whereas in the illuminance plot of Figure 6 the range of variation is reduced to $10^{0.65}$ (the ratio of the highest to the lowest threshold is only 4.5). The average range of variation in irradiance is 4.2 times that of the average range of variation in illuminance. The reductions in range for each subject may be seen in Table 3. Four of six subjects have ranges reduced by factors of 3 or more. One subject has been reduced by a factor of 2, and one subject shows an increase. This difference between subjects may reflect differences in individual luminosity. The major point is that when the inherent luminosity of lights of different wavelengths is factored out, the magnitude of the wavelength-dependent effect is reduced to an average factor of 4.5.

TABLE 3. REDUCTION IN RANGE OF THRESHOLD VARIATION ACROSS WAVELENGTH BY CONVERTING FROM IRRADIANCE TO ILLUMINANCE

Subject	Log reduction	Linear reduction factor
1	0.934	8.60
2	-0.444	0.39*
3	0.560	3.63
4	0.764	5.81
5	0.285	1.93
6	0.611	4.08
Mean	0.616	4.13

*Subject 2 showed an increase in the range of variation after conversion from irradiance to illuminance.

Although the range of variation was reduced by plotting obscuration thresholds with respect to illuminance, it was not eliminated. The remaining variation was tested for statistical significance. The design of this experiment was a repeated-measures and fully-crossed model (each subject received each treatment). Significance was tested by a one-factor analysis of variance (ANOVA) (18). The results of that analysis showed significance ($F = 9.48$, $p < .001$, $df_{num} = 4$, $df_{denom} = 20$), indicating that thresholds for at least one wavelength differ from thresholds for other wavelengths. Subsequent post-hoc analysis using the Newman-Keuls multiple comparison test showed that the 488-nm mean was significantly different from the 568-nm and 647-nm means at the 0.05 significance level. No other means were different. Furthermore, no mean at any wavelength was significantly different from the grand mean, averaged across wavelengths. There is a significant wavelength effect, but it is small and subtle.

The inter-subject differences shown in Figure 6 are large and obvious. For example, at 530 nm, the least sensitive subject is 1/10th as sensitive as the most sensitive subject. A ratio of almost 10:1 in inter-subject differences holds true for all tested wavelengths below 568 nm, supporting the idea that most of the inter-subject differences may be independent of wavelength. This suggestion is tested in Figure 7 by shifting each subject's curve on the ordinate by an amount equal to its mean (across wavelength) value which centers all the curves around zero. Because this is a logarithmic plot, the shift is formally equivalent to normalizing each curve so that it has a mean value of 1.0. When the data are shifted in this manner, much of the inter-subject variability is seen to be independent of wavelength because the subjects' curves become much more similar. Figure 7 shows the extent to which thresholds are wavelength dependent after correcting for luminance and for wavelength-independent individual differences among subjects.

An ANOVA was also performed on the shifted data and was again significant ($F = 9.336$, $p < .001$, $df_{num} = 4$, $df_{denom} = 20$). Further analysis with the Newman-Keuls test revealed that the 488-nm mean differed significantly from the 514-nm and 568-nm means at the 0.05 level. These were the only significant comparisons.

Individual differences in overall sensitivity could be due to any of a number of factors. One important candidate is age. As subjects get older, the amount of light scattered by their ocular media increases (19). Age-related differences among subjects are expected to be greatest at short wavelengths because of an age-related increase in optical density at short wavelengths (20). Although the experiment was not designed to test the influence of age on thresholds, support for the aging hypothesis may be seen in our data. The rank order correlation between overall illuminance threshold (distance from zero in Figure 6) and age is statistically significant for every wavelength except 647 nm (correlations average -0.71).

This study was undertaken to answer whether there is a wavelength dependence for glare thresholds other than that produced by luminance sensitivity. The answer to this question is given in Figure 7. There is a reliable wavelength dependence seen in this curve, but it is relatively small when compared to the wavelength dependence seen for radiometric data.

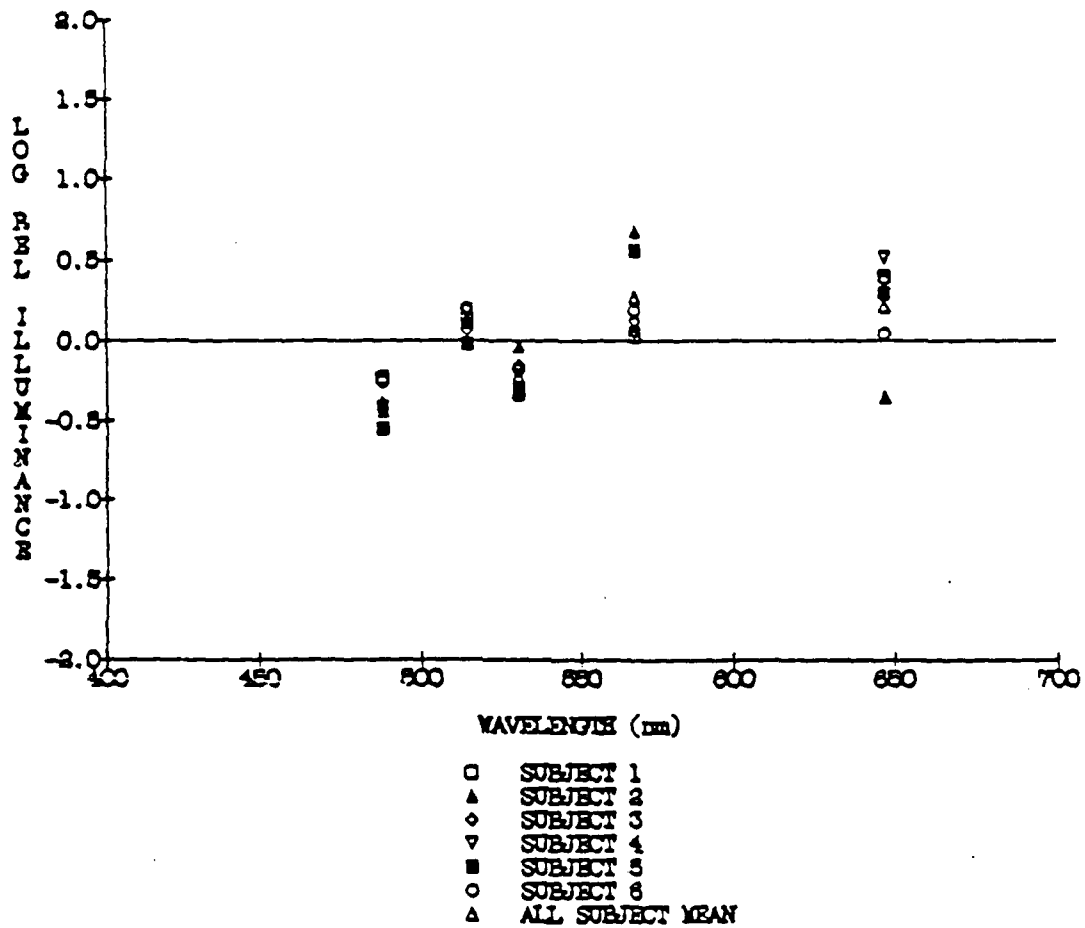

Figure 7. Normalized illuminance data. This is a replot of data from Figure 6 except that each subject's data have been shifted on the ordinate. The amount of the shift is that which gives each subject an across-wavelength mean of zero.

Several factors could cause the residual wavelength dependence. Random variation may have caused the significant comparisons (488-nm, from 514-nm and 568-nm means). A second factor could be introduced by the optical train. If the fiber-optic cable used to produce the "point" sources introduced small differences in source size that varied with wavelength, then the glare spread would also vary. Any such variations in source size would be difficult to measure. A third possible source of wavelength variation is that of the optical power introduced by the canopy and the HUD combiner plate. Variations in the magnification caused by the curved canopy-HUD system could result in different sized "point" sources, and consequently, in wavelength-dependent thresholds. A fourth factor is that of the luminosity function itself. There is evidence that the standard V_λ function does not capture the true shape of luminance sensitivity at every brightness level and adaptation state (21,22). The deviations from zero in Figure 7 may simply result from an inappropriate correction for luminance. Last, the data may represent a true wavelength effect indicative of sensitivity to purely chromatic contrast (23). Such an effect certainly has theoretical interest and some practical importance as well, but the wavelength effect is much smaller than the effects due to luminance and to subjects.

The relative magnitudes of the chromatic and subjects effects are illustrated in Figure 8. In this figure, the results of a model of laser propagation through the atmosphere (24,25) are displayed for a 488-nm, 5 W argon laser, at sea level on a clear winter day. These model calculations are for illustration only and are not meant to establish, or to be used as, standards. The innermost contour (labeled " G_m ") is the distance at which the laser produces an illuminance equal to the average threshold illuminance for all subjects independent of wavelength. It is the "keep-out" distance predicted by a simple illuminance model. The second contour (labeled " λ_m ") shows the mean illuminance threshold for all subjects at 488 nm. The 488-nm threshold was chosen because the mean among subjects there differed from the grand mean. The λ_m contour plots the prediction made from a model that assumes there is a true chromatic effect. The difference between the two contours is the worst-case error for the average subject produced by the wavelength effect alone. The outer contour (labeled "extreme") is that obtained for the most extreme subject at this wavelength. In this case, the subject is more sensitive to 488-nm light than predicted by the average. The difference between the inner and outer contours is the worst-case error for an individual subject. Errors are larger for subjects than for wavelength. If a correction for chromatic sensitivity at this wavelength were made, errors due to differences among subjects would be reduced, but would still be important. The size of the remaining error is given by the distance between the outer and middle contours.

In Figure 9, data for a 568-nm laser are pictured. There, the most extreme subject is much less sensitive to the glare than is predicted by the mean illuminance threshold. Consequently, that subject reaches threshold at a closer distance than would the mean subject. Correcting for wavelength in both examples improves the prediction, but a larger subjects effect remains. The (possibly age-related) wavelength-independent variation in threshold due to subjects is the largest and most important finding reported here. Any future modeling or investigations should examine this issue.

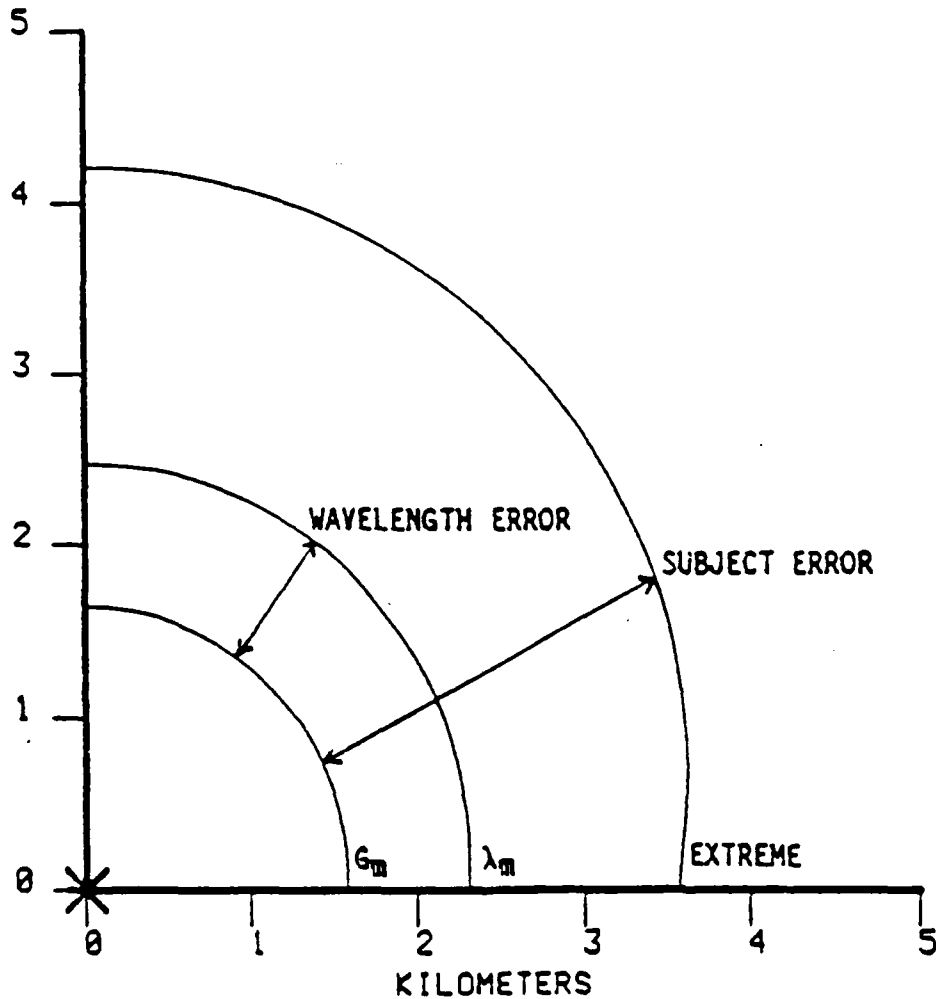

Figure 8. Illustration of relative magnitudes of errors due to averaging among subjects. The X at the origin indicates the location of a source laser (488 nm, 5 W). G_m labels the contour of distance from the laser at which the irradiance equals the mean illuminance threshold among subjects and among wavelengths. λ_m labels the contour of irradiance equal to the mean illuminance threshold among subjects for 488 nm. "Extreme" labels the contour of irradiance equal to the threshold illuminance for the most extreme subject (more sensitive to the light than the mean subject and hence, at threshold at a greater distance). "Wavelength Error" is the worst-case error produced by averaging among wavelengths. "Subject Error" is the worst-case error produced by averaging over subjects and wavelengths.

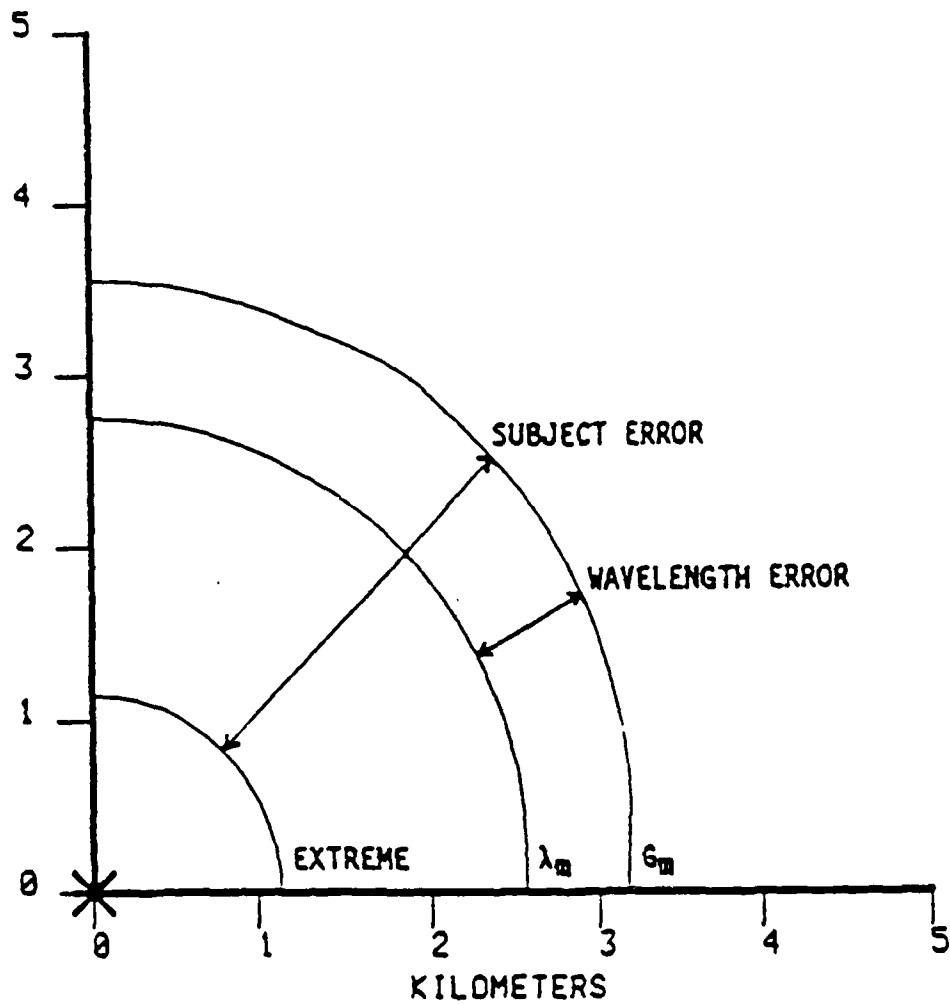

Figure 9. Illustration of relative magnitudes of errors due to averaging among wavelengths and errors due to averaging among subjects. It is the same as Figure 8 except for the laser (568 nm, 5 W) and except that the most extreme subject is less sensitive to the light than is the mean subject.

REFERENCES

1. Allen, R.G. Retinal thermal injury. Non-ionizing radiation. Proceedings of an ACGIH Topical Symposium, Washington, D.C., 1979.
2. Zuclich, J.A. Ultraviolet laser radiation injury to the ocular tissues. Proceedings of the Symposium on "Effets Biologiques des Faisceaux Lasers et Normes de Protection," Paris, France, 1986.
3. Glickman, R.D. Differential effects of short- and long-pulsewidth laser exposures on retinal ganglion cell response. *Lasers Surg Med* 7:434-440 (1987).
4. Miller, N.D. Positive afterimage following brief high-intensity flashes. *J Opt Soc Am* 56:802-806 (1966).
5. Miller, N.D. Positive afterimage as a background luminance. *J Opt Soc Am* 56:1616-1620 (1966).
6. Vos, J.J. Disability glare--A state-of-the-art report. *CIE-J* 3:39-53 (1984).
7. Westheimer, G. The eye as an optical instrument, ch. 4, pp. 4-12 - 4-19. In K.R. Boff, L. Kaufman, and J.P. Thomas (eds.). *Handbook of Perception and Human Performance*. New York: Wiley & Sons, 1986.
8. Hood, D.C., and M.A. Finkelstein. Sensitivity to light, ch. 5, pp. 5-5 - 5-59. In K.R. Boff, L. Kaufman, and J.P. Thomas (eds.). *Handbook of Perception and Human Performance*. New York: Wiley & Sons, 1986.
9. Wooten, B.R., and G.A. Geri. Psychophysical determination of intra-ocular light scatter as a function of wavelength. *Vision Res* 27:1291-1298 (1987).
10. Boynton, R.M. *Human color vision*, pp. 183-206. New York: Holt, Rinehart, and Winston, 1979.
11. Stiles, W.S. The directional sensitivity of the retina and the spectral sensitivities of the rods and cones. *Proc Soc Lond [Biol]* 127:54-95 (1939).
12. Wandell, B.A., and E.N. Pugh, Jr. Detection of long-duration, long-wavelength incremental flashes by a chromatically coded pathway. *Vision Res* 20:625-636 (1980).
13. Thornton, J.E., and E.N. Pugh. Red/green color opponency at threshold. *Science* 219:191-193 (1983).
14. Previc, F.H. Color-specific effects of intense laser exposure on visual evoked potentials in rhesus monkeys. *Aviat Space Environ Med* 58:1103-1108 (1987).

15. Schmeisser, E.T. Laser flash effects on chromatic discrimination in monkeys. USAFSAM-TR-87-17, Oct 1987.
16. Hurvich, L.M., and D. Jameson. An opponent-process theory of color vision. *J Psychol Rev* 64(6):384-404 (1957).
17. American National Standards Institute. American National Standard for the Safe Use of Lasers. ANSI Z136.1. New York: ANSI, 1986.
18. Keppel, G. *Design and analysis: a researcher's handbook*. Englewood Cliffs, NJ: Prentice-Hall, 1973.
19. Olson, P.L., and M. Sivak. Glare from automobile rear-vision mirrors. *Human Factors* 26(3):269-282 (1984).
20. Pokorny, J., V.C. Smith, G. Verriest, and A.J.L.G. Pinckers. Congenital and acquired color vision defects, pp. 59-60 and 243-245. New York: Grune and Stratton, 1979.
21. Sperling, H.G., and R.S. Harwerth. Red-green cone interactions in the increment-threshold spectral sensitivity of primates. *Science* 172:180-184 (1971).
22. Boynton, R.M. *Human color vision*, pp. 300-308. New York: Holt, Rinehart, and Winston, 1979.
23. Brown, W.R.J., and D.L. MacAdam. Visual sensitivities to combined chromaticity and luminance differences. *J Opt Soc Am* 39:809-834 (1949).
24. Kneizys, F.X., E.P. Shettle, W.O. Gallery, J.H. Chetwynd, Jr., L.W. Abreu, J.E.A. Selby, S.A. Clough, and R.W. Fenn. *Atmospheric transmittance/radiance: computer code LOWTRAN 6*. AFGL-TR-83-0187, Aug 1983.
25. Labo, J. Personal communication, Jan 1988.