

2

TECHNICAL REPORT HL-84-4

# OLD RIVER DIVERSION, MISSISSIPPI RIVER

Report 4

## OUTFLOW CHANNEL INVESTIGATIONS

### Hydraulic Model Investigation

by

C. R. Nickles, T. J. Pokrefke, Jr.

Hydraulics Laboratory

DEPARTMENT OF THE ARMY

Waterways Experiment Station, Corps of Engineers  
PO Box 631, Vicksburg, Mississippi 39181-0631

AD-A207 019

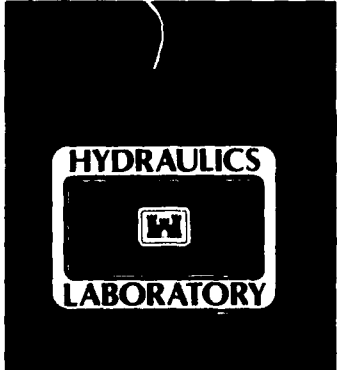
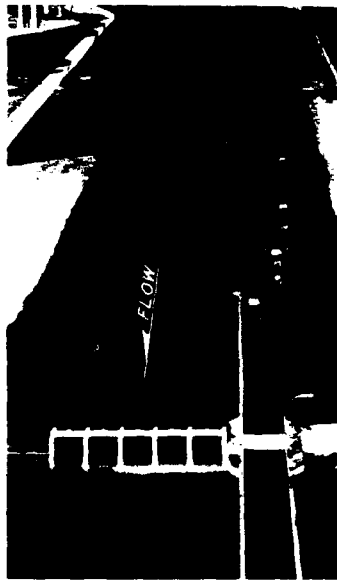
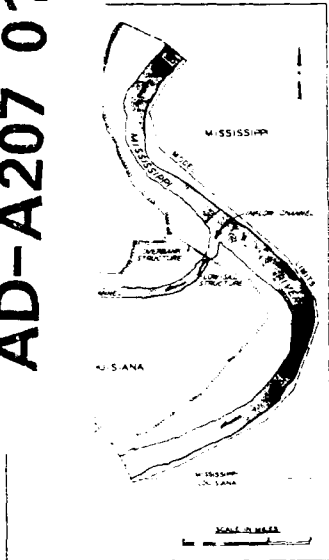

April 1989

Report 4 of a Series

Approved For Public Release; Distribution Unlimited

**DTIC**  
**ELECTE**  
**APR 24 1989**  
**S E D**

Prepared for US Army Engineer District, New Orleans  
New Orleans, Louisiana 70160-0267

089 4 24 081

Destroy this report when no longer needed. Do not return  
it to the originator.

The findings in this report are not to be construed as an official  
Department of the Army position unless so designated  
by other authorized documents.

The contents of this report are not to be used for  
advertising, publication, or promotional purposes.  
Citation of trade names does not constitute an  
official endorsement or approval of the use of  
such commercial products.

Unclassified

ADA207019

SECURITY CLASSIFICATION OF THIS PAGE

REPORT DOCUMENTATION PAGE				Form Approved OMB No. 0704-0188	
1a REPORT SECURITY CLASSIFICATION Unclassified		1b RESTRICTIVE MARKINGS			
2a SECURITY CLASSIFICATION AUTHORITY		3 DISTRIBUTION / AVAILABILITY OF REPORT Approved for public release; distribution unlimited.			
2b DECLASSIFICATION / DOWNGRADING SCHEDULE					
4 PERFORMING ORGANIZATION REPORT NUMBER(S) Technical Report HL-84-4		5 MONITORING ORGANIZATION REPORT NUMBER(S)			
6a. NAME OF PERFORMING ORGANIZATION USAEWES Hydraulics Laboratory		6b. OFFICE SYMBOL (if applicable) CEWES-HR-P	7a. NAME OF MONITORING ORGANIZATION		
6c. ADDRESS (City, State, and ZIP Code) PO Box 631 Vicksburg, MS 39181-0631		7b. ADDRESS (City, State, and ZIP Code)			
8a. NAME OF FUNDING / SPONSORING ORGANIZATION USAED, New Orleans		8b. OFFICE SYMBOL (if applicable)	9. PROCUREMENT INSTRUMENT IDENTIFICATION NUMBER		
8c. ADDRESS (City, State, and ZIP Code) PO Box 60267 New Orleans, LA 70160-0267		10. SOURCE OF FUNDING NUMBERS			
		PROGRAM ELEMENT NO.	PROJECT NO.	TASK NO.	WORK UNIT ACCESSION NO.
11. TITLE (Include Security Classification) Old River Diversion, Mississippi River, Report 4, Outflow Channel Investigations; Hydraulic Model Investigation					
12. PERSONAL AUTHOR(S) Nickles, C. R.; Pokreike, T. J. Jr.					
13a. TYPE OF REPORT Report 4 of a Series		13b. TIME COVERED FROM _____ TO _____	14. DATE OF REPORT (Year, Month, Day) April 1989		15. PAGE COUNT 55
16. SUPPLEMENTARY NOTATION Available from National Technical Information Service, 5285 Port Royal Road, Springfield, VA 22161.					
17. COSATI CODES			18. SUBJECT TERMS (Continue on reverse if necessary and identify by block number)		
FIELD	GROUP	SUB-GROUP	Hydraulic models	Outflow channel	
			Mississippi River	Tailwater control	
			Old River Diversion		
19. ABSTRACT (Continue on reverse if necessary and identify by block number) The outflow channel investigation was conducted to study possible means of repairing damage to or preventing future conditions that could endanger the stability of the low-sill structure. The 1:120-scale undistorted fixed-bed model was used to study flow conditions during rehabilitation of damage to the stilling basin, the need for additional scour protection in the outflow channel below the stilling basin, a means of controlling the tailwater of the low-sill structure, and the possibility of replacing the left downstream wing wall with a rock structure if the existing wing wall were to fail. Results of the studies indicated no adverse flow conditions would be produced by the closing required during partial completion of the stilling basin rehabilitation work. Scour velocities in the unprotected areas of the outflow channel could be expected to reach 10 fps. The two types of tailwater control structures, rock weirs and concrete piling schemes, would not satisfactorily control the low-sill structure tailwater as desired and would severely (Continued)					
20. DISTRIBUTION / AVAILABILITY OF ABSTRACT <input checked="" type="checkbox"/> UNCLASSIFIED/UNLIMITED <input type="checkbox"/> SAME AS RPT <input type="checkbox"/> DTIC USERS			21 ABSTRACT SECURITY CLASSIFICATION Unclassified		
22a. NAME OF RESPONSIBLE INDIVIDUAL			22b TELEPHONE (Include Area Code)	22c OFFICE SYMBOL	

Unclassified

SECURITY CLASSIFICATION OF THIS PAGE

19. ABSTRACT (Continued).

limit or prevent navigation to the area below the structure. If failure of the left downstream wing wall occurs, a rock structure could be used as a satisfactory replacement.

Unclassified

SECURITY CLASSIFICATION OF THIS PAGE

PREFACE

The model investigation reported herein was authorized by the Headquarters, US Army Corps of Engineers (USACE). This portion of the study was conducted for the US Army Engineer District, New Orleans (LMN), in the Hydraulics Laboratory of the US Army Engineer Waterways Experiment Station (WES), Vicksburg, MS, during the period August 1973 to July 1977, in conjunction with other model testing.

During the course of the model study, LMN was kept informed of the progress of the study through monthly reports and interim reports of special results. In addition, representatives of USACE, LMN, and the US Army Engineer Division, Lower Mississippi Valley, visited WES at intervals to observe model tests and discuss test results.

The investigation was conducted under the general supervision of Mr. H. B. Simmons (retired), Chief of the Hydraulics Laboratory, and under the direct supervision of Mr. J. E. Glover (retired), Chief of the Waterways Division. The engineers in immediate charge of the model were Messrs. B. K. Melton (retired) and T. J. Pokrefke, Jr., Chief of the Potamology Branch, assisted by Messrs. C. R. Nickles, C. W. O'Neal, Jr., E. E. Moorehead (retired), B. T. Crawford, and L. Brown, all of the Potamology Branch. This report was prepared by Messrs. Nickles and Pokrefke and edited by Mrs. M. C. Gay, Information Technology Laboratory, WES.

COL Dwayne G. Lee, EN, is the Commander and Director of WES.  
Dr. Robert W. Whalin is the Technical Director.

Accession For	
NTIS GRA&I	<input checked="" type="checkbox"/>
DTIC TAB	<input type="checkbox"/>
Unannounced	<input type="checkbox"/>
Justification	
By _____	
Distribution/	
Availability Codes	
Dist	Avail and/or Special
A-1	

CONTENTS

	<u>Page</u>
PREFACE.....	1
CONVERSION FACTORS, NON-SI TO SI (METRIC)	
UNITS OF MEASUREMENT.....	3
PART I:  INTRODUCTION.....	5
Background.....	5
Purpose of Study.....	6
Model Testing.....	7
PART II:  STILLING BASIN REHABILITATION.....	9
Test Procedure.....	9
Test Results.....	9
PART III:  OUTFLOW CHANNEL SCOUR PROTECTION.....	11
Test Procedure.....	11
Test Results.....	12
PART IV:  LOW-SILL STRUCTURE TAILWATER CONTROL.....	13
Test Procedure.....	13
Test Results.....	13
PART V:  LEFT DOWNSTREAM WING WALL REPLACEMENT.....	23
Test Procedure.....	23
Test Results.....	23
PART VI:  DISCUSSION OF RESULTS AND CONCLUSIONS.....	24
Limitations of Model Results.....	24
Summary of Results and Conclusions.....	24
TABLES 1-5	
PHOTOS 1-4	
PLATES 1-18	

CONVERSION FACTORS, NON-SI TO SI (METRIC)  
UNITS OF MEASUREMENT

Non-SI units of measurement used in this report can be converted to SI  
(metric) units as follows:

<u>Multiply</u>	<u>By</u>	<u>To Obtain</u>
cubic feet	0.02831685	cubic metres
feet	0.3048	metres
miles (US statute)	1.609344	kilometres

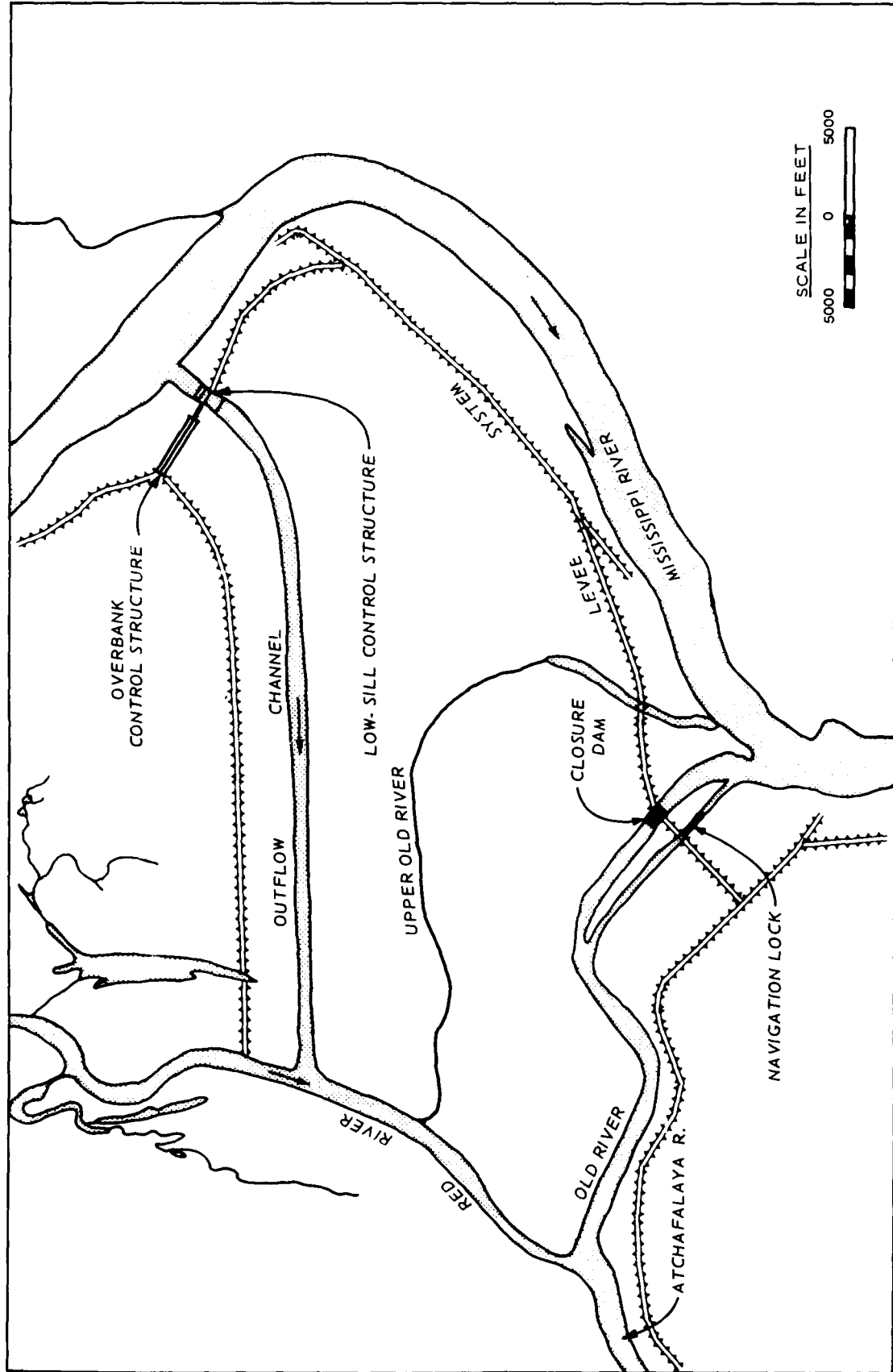

Figure 1. Location map

OLD RIVER DIVERSION, MISSISSIPPI RIVER

OUTFLOW CHANNEL INVESTIGATIONS

Hydraulic Model Investigation

PART I: INTRODUCTION

Background

1. Prior to the construction of the Old River control structures, the Atchafalaya River, a principal distributary of the Mississippi River through a short connecting channel, had been increasing in capacity to such an extent as to threaten to divert the Mississippi River through its much shorter and steeper route to the Gulf of Mexico. In order to control flow from the Mississippi River and prevent its capture by the Atchafalaya River, the short connecting channel was closed with a dam and navigation lock, the existing Mississippi River levee above and below the channel were connected, and two control structures within the existing Mississippi River levee were constructed at mile 314.5 above Head of Passes (AHP). The control structures included a low-sill structure 548.5 ft\* long and an overbank structure approximately 3,383 ft long which operates during flood flows (Figure 1). Complete details and descriptions of the Old River control structures can be found in Report No. 1.\*\*

2. When the low-sill structure was placed in operation in 1964, a deep scour hole began developing downstream of the low-sill structure end sill. The scour hole was revetted and believed to be no serious problem until 1973. During the Mississippi River flood of 1973, scour behind the left upstream wing wall of the low-sill structure caused failure of the wing wall and a scour hole to develop under the structure and stilling basin slabs. This scour exposed the foundation pilings and seriously weakened the stability of

---

\* A table of factors for converting non-SI units of measurement to SI (metric) units is presented on page 3.

\*\* J. J. Franco and C. R. Nickles. "Old River Diversion, Mississippi River; Report 1, Introduction, Description, Adjustment and Verification of Models, and Summary of Results" (in preparation), US Army Engineer Waterways Experiment Station, Vicksburg, MS.

the low-sill structure. Concern that the low-sill structure could fail if the hole underneath the structure and the scour hole below the end sill were to connect resulted in an examination of possible repairs to the structure to improve its stability and events that might further weaken the structure.

#### Purpose of Study

3. The purpose of the outflow investigations was to evaluate and provide guidance relative to rehabilitation of the stilling basin of the low-sill structure, scour protection in the outflow channel, tailwater control measures downstream from the low-sill structure, and feasibility of a rock replacement structure for the left downstream wing wall. The need for rehabilitation of the stilling basin became apparent during a survey of the basin, which revealed severe erosion of the slab between the baffle blocks and the end sill and a crack in the slab behind gate bay 9. The erosion below the baffle blocks was 1 to 1.5 ft deep and exposed the reinforcement rods. Rock passing through the structure had become entangled in the reinforcement, producing a mass up to 6 ft in height. The proposed plan for rehabilitating the end sill was to convert the present vertical end sill to a sloped one by placing 1-in.-thick steel plate from the last row of baffle blocks to the top of the end sill and filling the void with concrete. When the first plates were placed and before the void could be filled, it became necessary to reopen gates that had been closed to allow the placing of the plates. When the gates were reclosed, it was discovered that some of the plates had worked loose and were believed washed downstream; therefore, investigations were conducted to determine the effects of closing various gates during rehabilitation of the stilling basin on flow conditions and the discharge through the low-sill structure. To ensure the integrity of the damaged low-sill structure, measures to protect the outflow channel and limit the head on the structure were considered. Except for a small area of the left bank, the area below the structure was revetted with articulated concrete mattress; however, additional protection was believed necessary. Model study results could provide information needed to evaluate the type of protection needed and the effect of any change in head differential at the control structure on the outflow channel. Based on prototype observations, there was concern that the left downstream wing wall could fail and cause adverse flow conditions below the structure.

Guidance for replacing this wall with a rock structure was considered necessary in case the wall failed.

#### Model Testing

4. Testing in the 1:120-scale undistorted fixed-bed model (Figure 2) consisted of water-surface elevation measurements, discharge measurements, and velocity measurements. During testing for the stilling basin rehabilitation, various combinations of gates were closed for a specified Mississippi River discharge and the effect on the head differential and discharge through the structure was recorded. Velocity measurements were obtained to determine the effect of the closings on the rehabilitation work and the area surrounding the structure. Scour protection tests consisted of velocity measurements between ranges 9+00 and 20+00 in the outflow channel for a series of flows using tailwater elevations produced by maximum, minimum, and average Red River contributions for expected tailwater conditions. Two types of tailwater control structures, rock weirs and concrete piling, were tested in the outflow channel. The rock weir schemes consisted of one to seven weirs at el -5 ft NGVD\* with varying crest lengths and spacings in the channel with the weir farthest upstream always at range 135+00, which is approximately 2 miles below the low-sill structure. The concrete piling schemes consisted of nine rows of pilings with the row farthest upstream at range 135+00 of the outflow channel. This testing was done with the low-sill structure in orifice control operation. Orifice control operation is a method of operating the low-sill structure with the vertical lift gates of the structure partially submerged so that flow is passed underneath the gates through an opening below the surface of the water. The locations of the gages used in the model are shown in Plate 1, with Gages 12 and 13 being the low-sill structure headwater and tailwater, respectively. The wing wall replacement consisted of removing the existing left downstream wing wall and replacing it with a rock structure.

---

\* All elevations (el) and stages cited herein are in feet referred to the National Geodetic Vertical Datum (NGVD).

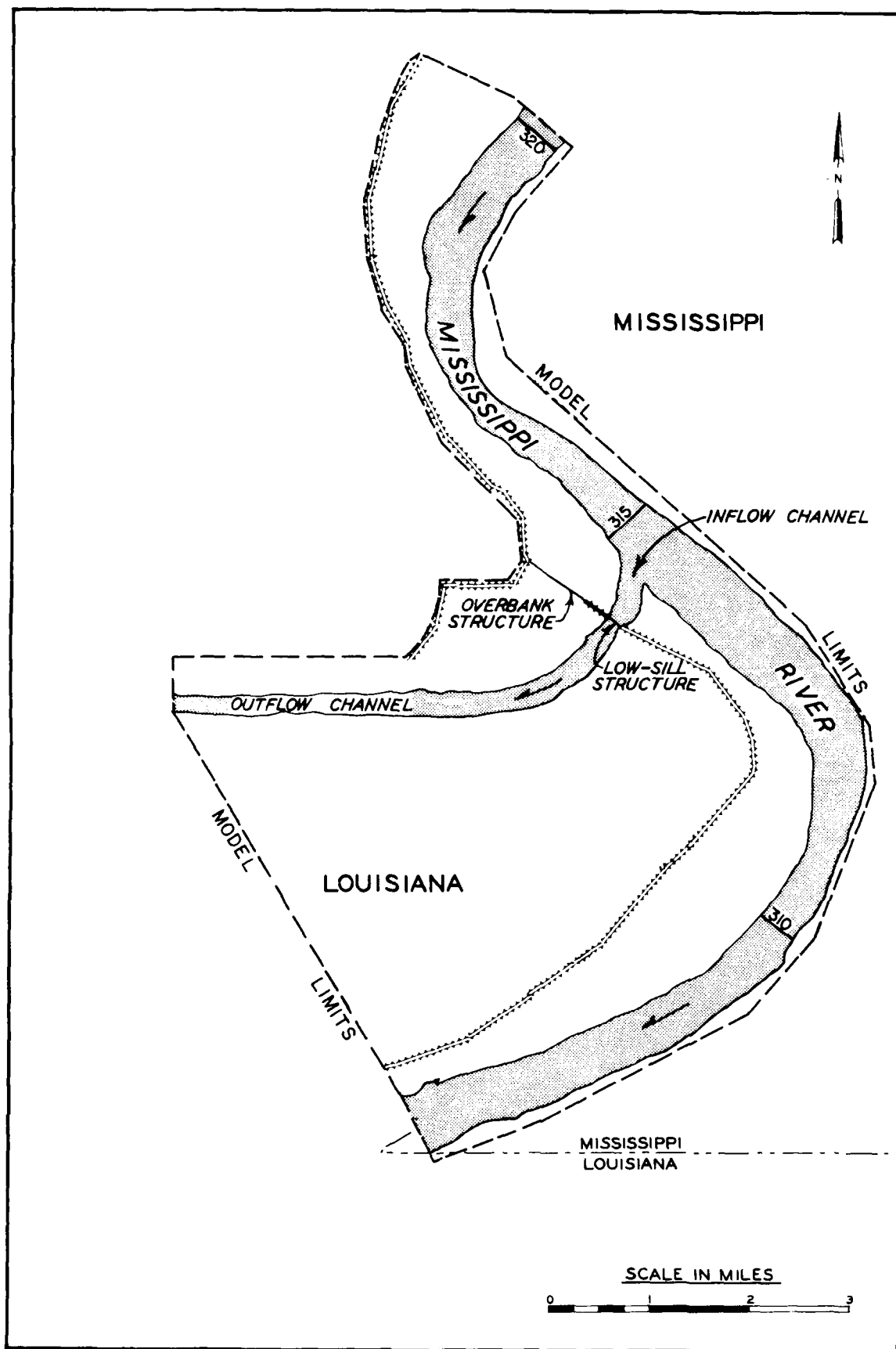

Figure 2. 1:120-scale undistorted fixed-bed model

## PART II: STILLING BASIN REHABILITATION

### Test Procedure

5. Evaluations of possible gate closure combinations to aid in the construction of the rehabilitation work were made from visual observations, headwater-tailwater measurements, and meter velocities near the low-sill structure. The combinations of gates closed varied from closing one gate at a time to closing five adjacent gates. Each combination was tested for a Mississippi River discharge of 200,000 cfs. All combinations were compared to a base condition of all gates open and the Old River discharge of 69,000 cfs with a headwater stage (Gage 12) of 15.2 ft and a tailwater stage (Gage 13) of 5.9 ft. The only change made to the model from the base conditions for each test was the closing of the gate or gates. Velocities at 0.6 depth and near the bottom of the channel were obtained immediately upstream of each gate bay of the structure; at ranges 150 ft upstream of the structure; and at 120, 200, 400, and 600 ft below the downstream end of the structure piers. Evaluations of partial or complete rehabilitation of the stilling basin were made from observations of current patterns below the structure. Photographs of surface current patterns were obtained for various combinations of partial or complete rehabilitation for Mississippi River discharges of 395,000 and 1,150,000 cfs with Old River discharges of 100,000 and 258,000 cfs, respectively. Each discharge was tested for conditions of no repair; low bays (6, 7, and 8) repaired; bays 1, 2, 6, 7, and 8 repaired; and bays 1 through 8 repaired.

### Test Results

6. Table 1 shows the changes in the Old River discharge, headwater, and tailwater produced by the various gate closure schemes. The results indicate that the discharge would vary from 35,000 to 70,000 cfs and the head differential across the structure would vary from 9.3 to 15.5 ft. The maximum head differential would occur when the closure scheme included a combination of Gates 5, 6, and 7. The maximum head differentials of 15.5 and 15.3 ft occurred when Gates 4, 5, 6, and 7, and 5, 6, 7, and 8 were closed, respectively. These conditions also produced the minimum Old River discharge of 35,000 cfs. Meter velocities of the base condition (Plate 2) indicated the

bottom velocities near the end sill, 120 ft below the piers, would vary from 1.6 fps behind Gate 1 to 9.5 fps behind Gate 6 to 3.0 fps behind Gate 11. The maximum 0.6-depth velocity was 12.4 fps behind Gate 5. The results of the velocity measurements with the gates closed indicated the bottom velocity behind the closed gate would range from 0.5 fps to a maximum of 6.5 fps. Maximum bottom velocities of 15.0 fps at the end sill and 12.0 fps at 200 ft below the open gate bays were measured for some conditions (Plates 3 and 4). These maximum bottom velocities occurred in an area that is protected and were not considered high enough to cause problems. No adverse flow patterns were observed for any of the combinations tested. Observations of flow conditions below the low-sill structure of the partially completed or fully completed rehabilitation work indicate that the flow conditions will remain generally the same during and after the rehabilitation work. Photos 1 and 2 show surface flow patterns below the structure before rehabilitation for Mississippi River discharges of 395,000 and 1,150,000 cfs, respectively, and Photos 3 and 4 show the patterns after rehabilitation for the two flows tested.

PART III: OUTFLOW CHANNEL SCOUR PROTECTION

Test Procedure

7. Point velocities were obtained between ranges 9+00 and 20+00 of the outflow channel for a series of low-sill structure headwater stages from 24 to 64 ft for future tailwater conditions with an average Red River contribution. The future tailwater for each stage was provided by the US Army Engineer District, New Orleans. The tailwater conditions with average Red River contribution are shown in Plate 5 as a plot of headwater versus future tailwater with average Red River contribution. From this plot the following flow data were obtained for testing:

<u>Low-Sill Structure Headwater, ft</u>	<u>Low-Sill Structure Tailwater, ft</u>
24	13.2
30	18.3
36	22.5
40	24.7
44	27.1
48	29.6
52	31.8
56	34.4
60	38.2
64	43.2

For the headwater stages above 52 ft, the flow was tested with the overbank structure closed and in operation. The plot in Plate 5 is for the overbank structure in operation. The low-sill tailwater will change slightly when the overbank structure is closed; therefore, the tailwater elevation was increased 0.2 ft for the 56-, 60-, and 64-ft headwater stages with the overbank structure closed. A 53-ft stage was tested using future tailwater conditions with average, maximum, and minimum Red River contributions. The tailwater elevations used were 32.2, 31.4, and 33.6 ft, respectively.

### Test Results

8. Results of velocity measurements indicated the thread of maximum bottom velocities would occur at a stage of 52 to 53 ft about 200 ft to the left of the low-sill structure center line, which is in an area that is unprotected by revetment. Plate 6 shows the velocities obtained for stages of 48 and 52 ft. The results indicate that the maximum bottom velocity in the unprotected area would be 9.3 and 10.2 fps for the 48- and 52-ft stages, respectively. Plate 7 shows the velocities obtained with the 53-ft stage and the average, minimum, and maximum Red River contributions. The results indicated the maximum bottom velocity for the average and minimum Red River contributions would be about 10 fps in the unprotected area. With the maximum Red River contribution, the maximum bottom velocity was reduced to about 6.5 to 7 fps.

## PART IV: LOW-SILL STRUCTURE TAILWATER CONTROL

### Test Procedure

9. Evaluations of the proposed tailwater control structures were obtained from visual observations, water-surface elevation measurements, and meter velocities at 0.6 and bottom depths at various points at or near the structures. For all flows tested, the tailwater of the control structure was controlled at the elevation furnished by the New Orleans District.

10. Water-surface elevations were measured at points to the side of the weir section to eliminate the effects of the velocity head on the readings obtained. Headwater and tailwater elevations were obtained 500 ft upstream and downstream of the weir structure or system of structures for each rock weir plan tested. Additional water-surface elevations were obtained between the individual structures for plans consisting of more than one weir. Headwater and tailwater elevations for the piling system plans were measured in the center of the outflow channel 360 ft upstream and downstream of the system. Additional water-surface elevations were obtained between the rows of pilings for some of the test.

11. Additional tests were conducted on various flows to determine the possibility of navigation through the structures. Visual observations of the model tow capable of reproducing a prototype speed of 12 mph in slack water and representing a total width of 70 ft were used to evaluate the tailwater control structure's effect on navigation (Figure 3).

### Test Results

#### Plan 1

12. Description. Plan 1 consisted of a single rock weir in the low-sill structure outflow channel at range 135+00. The crest of the weir was 70 ft wide (Plate 8) at el -5. The weir section was connected to each bank by a rock structure with crest el 50 and 1V on 3H side slopes. The structure extended across the overbank to tie into an abandoned railroad fill. Old River discharges of 100,000 and 160,000 cfs were used to evaluate the plan. Each flow was tested using tailwater elevations based on a maximum and minimum Red River contribution. The maximum and minimum Red River contributions to the tailwater elevations for the 100,000-cfs flow were the same, 14.0 ft, and

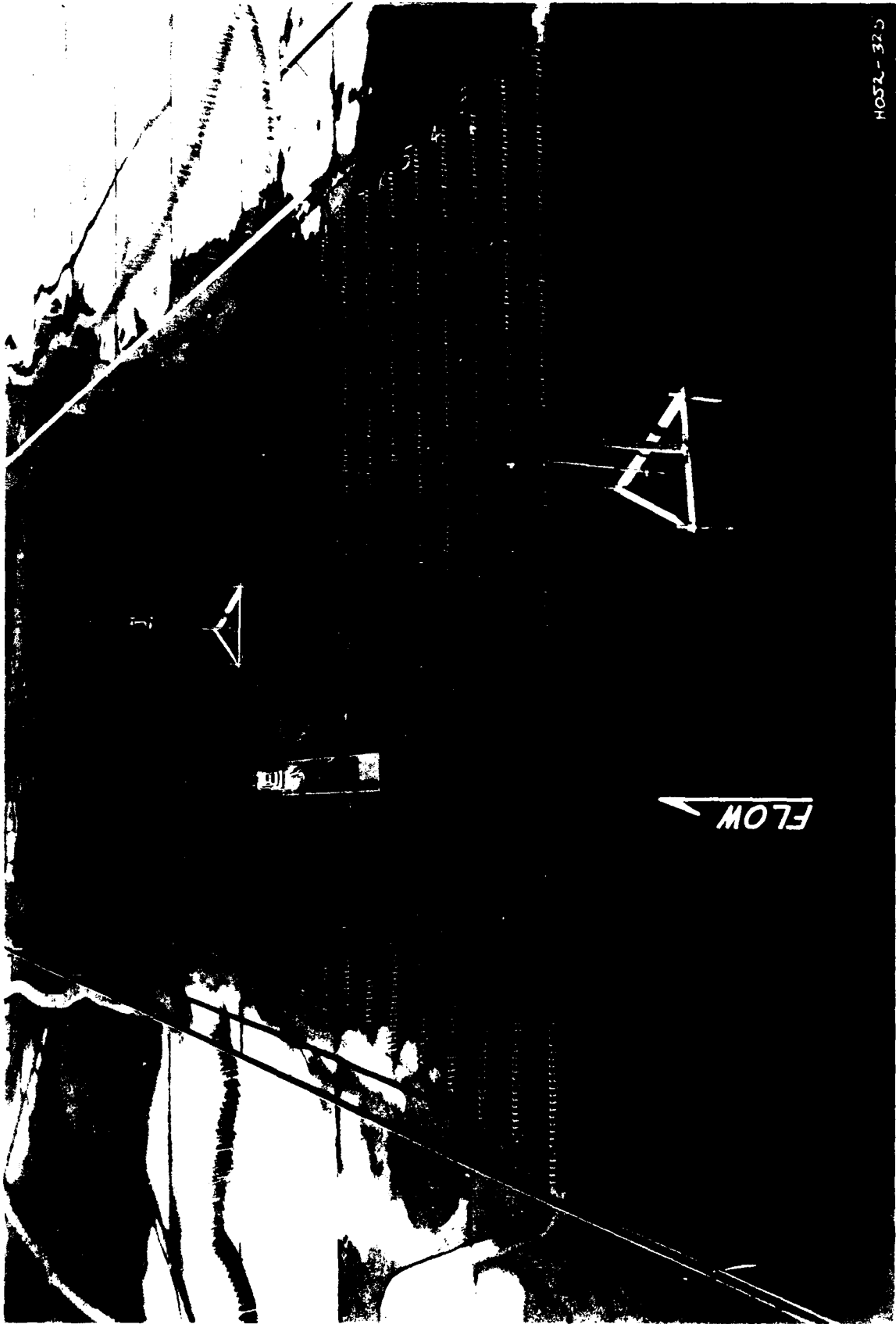

Figure 3. Model towboat navigating through tailwater control pile system

for the 160,000-cfs flow were 25.2 and 23.5 ft, respectively.

13. Results. The following tabulation shows the headwater elevations obtained 500 ft upstream of the weir for each tailwater elevation. These resulting head differentials were considered excessive and no further testing was conducted on this plan.

<u>Old River Discharge, cfs</u>	<u>Water-Surface El</u>	
	<u>Headwater</u>	<u>Tailwater*</u>
100,000	34.2	14.0
160,000	44.7	23.5
	44.7	25.2

---

\* Control gage.

#### Plan 1-A

14. Description. Plan 1A was the same as Plan 1 except the width of the weir was lengthened to 200 ft (Plate 8). An Old River discharge of 237,000 cfs was added to the previous 100,000- and 160,000-cfs flows for evaluation of this plan. The maximum and minimum Red River contributions to the tailwater elevations were 33.4 and 30.3 ft, respectively, for the 237,000-cfs flow.

15. Results. The following tabulation shows the headwater elevations obtained for the three flows tested. Meter velocities obtained at the weir and 200, 400, 600, 800, and 1,000 ft downstream of the weir for discharges of 100,000, 160,000, and 237,000 cfs and tailwater elevations of 14.0, 23.5, and 33.4 ft, respectively, are shown in Plate 9. The results indicate the maximum velocities at the weir would range from 16.3 to 19.7 fps for the three flows

<u>Old River Discharge, cfs</u>	<u>Water-Surface El</u>	
	<u>Headwater</u>	<u>Tailwater*</u>
100,000	18.2	14.0
160,000	29.8	23.5
	30.8	25.2
237,000	40.0	30.3
	41.4	33.4

---

\* Control gage.

tested. The maximum velocities at 1,000 ft downstream of the weir would be 13.4, 16.1, and 22.4 fps for the 100,000-, 160,000-, and 237,000-cfs discharges, respectively. Although the head differentials were much less than those obtained in Plan 1, the velocities were considered too high to permit navigation to pass over the weir.

Plan 2

16. Description. Plan 2 consisted of seven weirs of the same type and elevation as Plan 1, except the weir section was 500 ft wide (Figure 4). The weir farthest upstream was at range 135+00 and tied to the railroad fill as in Plan 1. The six additional weirs were located 519, 1,029, 1,524, 1,998, 2,460, and 2,913 ft downstream of range 135+00; and their top elevation was the same as the overbank elevation at their location (Plate 8). These locations were developed to provide a spacing of 400 ft between the toes of the slopes of adjacent weirs. The weir sections were staggered from left to right across the outflow channel in order to follow the natural channel thalweg. Two additional Old River discharges, 315,000 and 380,000 cfs, were added to the three previous discharges for testing of this plan. Tailwater elevations were updated to correspond to a plot of desired headwater-tailwater elevations (Plate 10) furnished by the New Orleans District. Based on this plot, the following tailwater elevations were required for each flow:

<u>Discharge, cfs</u>	<u>Tailwater El</u>
100,000	13.0
160,000	22.3
237,000	28.8
315,000	34.5
380,000	38.8

17. Results. Table 2 shows the headwater elevations obtained for the five flows tested. The results indicate that the total head differential varied from 2.3 ft with the discharge of 100,000 cfs to 4.8 for the 380,000-cfs discharge. Approximately one-half to one-third of the total head loss occurred through the first weir. Velocities through the weir system (Plate 11) increased with the discharge and tended to become greater as the flow moved downstream. The greatest velocities were obtained with a flow of 315,000 cfs and occurred at the downstream weir. Velocities varied generally



Figure 4. Tailwater control Plan 2, seven rock weirs

from 7 to 9 fps with the 100,000-cfs discharge up to 10 to 14 fps with the 315,000-cfs discharge. Velocities did not increase with the 380,000-cfs discharge as there was flow around the lower four weirs onto the overbank area. These velocities are considered too high to allow navigation through the system.

### Plan 3

18. Description. Plan 3 (Plate 8) consisted of five weirs and was developed on the model to provide a maximum total headwater-tailwater differential of 7 ft with the total distributed proportionally throughout the system. The weirs were separated enough to allow for expansion below each weir. The upstream weir was located at range 135+00 as in the previous plans with the successive weirs located 1,532, 2,915, 4,270, and 5,630 ft downstream of the first weir (Figure 5). The crest elevation was -5 ft and the widths were varied from 660 to 330 ft. The upstream weir was tied into the abandoned railroad fill at el 50 and the remaining dikes were tied into the overbank, as in Plan 2. The weir crests were staggered from left to right across the channel, as in Plan 2. Testing was done for four of the five flows used for Plan 2 with two higher flows, 500,000 and 600,000 cfs, added. The tailwaters for the additional flows were 45.7 and 49.1 ft, respectively.

19. Results. Table 3 shows the headwater and tailwater elevations obtained for each flow tested. The results indicated the maximum differential for the system was 6.7 ft for flows between 237,000 and 380,000 cfs. The distribution of head loss was relatively uniform from weir to weir. For the 500,000- and 600,000-cfs discharges, the head loss drastically decreased with approximately 30 to 40 percent of the total head loss occurring at the first weir. The decrease in head loss was due to the overtopping of the lower four dikes and flow onto the overbank at these higher discharges, which drastically decreased their effectiveness as control structures. Velocities through the system, shown in Plate 12, indicate that, as in Plan 2, the velocities increased with discharge until the flow moved onto the overbank and had a tendency to become greater as flow moved downstream. The greatest velocities were obtained with a discharge of 315,000 cfs and occurred at the downstream weir. Velocities varied generally from 6 to 10 fps with the 100,000-cfs discharge to 8 to 15 fps with the 315,000-cfs discharge. Velocities were somewhat lower for flows above 315,000 cfs due to the overtopping and overbank flow at the lower four dikes. The velocities through the system were



Figure 5. Tailwater control Plan 3, five rock weirs

considered too high to permit navigation through the system.

Plan 4

20. Description. Plan 4 consisted of nine rows of 4.5-ft-diam concrete piles placed in the outflow channel. The first row was at range 135+00 and the remaining rows were spaced 100 ft apart downstream. The piles in each row were spaced 10 ft on centers and the piles of alternating rows were placed to align with the center of the opening of the row immediately upstream (Plate 13). The top of the piles was at el 48. Headwater and tailwater elevations were recorded at points 360 ft upstream and downstream of the system. Testing was conducted for seven flows ranging from 100,000 to 650,000 cfs using tailwater elevations furnished by the New Orleans District for the rock weir test (Plate 10). The flows and tailwaters used for testing were as follows:

<u>Discharge, cfs</u>	<u>Tailwater El</u>
100,000	13.0
200,000	26.1
300,000	33.6
400,000	40.2
500,000	45.8
600,000	49.1
650,000	50.0

21. Results. Table 4 shows the headwater and tailwater obtained for each flow. The results indicate that the head differential through the system ranged from 2.8 to 6.8 ft, with the maximum produced with the 400,000-cfs discharge. The head differentials were somewhat less for flows above 400,000 cfs due to overtopping of the piles and flow onto the overbank bypassing the system. Table 5 shows water-surface elevations between the rows of piles for discharges of 100,000 to 400,000 cfs. These results indicate that the total head loss through the system would be relatively uniformly distributed between each row, with no row producing more than approximately 20 percent of the total. Meter velocities (Plate 14) indicated the flow through the pile system to be generally uniform and stable; however, visual observation indicated turbulence around the piles. Velocities were generally uniform across the system and were in the range of 3 to 6.5 fps except along the right bank line at the

lower rows. Results indicate the velocities increased as the flow moved downstream. Maximum velocities were obtained with the 400,000-cfs discharge at the last row of piles with velocities of about 6.0 fps occurring 400 ft downstream of the row. Discharges above 400,000 cfs had a tendency to spill out onto the overbank area at the upper rows of piles, and the right overbank flow tended to reenter the system near the lower rows. Results indicated scour velocities as high as 11 fps could be expected where the overbank flow reenters the system.

#### Plan 5

22. Description. Plan 5 was the same as Plan 4 except a beam was added to each row of piles. The beam was 3 ft thick and was placed at el 48 on rows 1, 2, 8, and 9 and at el 50 on rows 3, 4, 5, 6, and 7 (Plate 13). The same flows were used for testing as in Plan 4.

23. Results. Table 4 shows the headwater and tailwater obtained for each discharge tested. The results indicate the head loss through the system varied from 2.8 to 7.1 ft. The maximum head loss occurred, as in Plan 4, with the 400,000-cfs discharge. Discharges that would not produce a headwater elevation of 45 would not be affected by the beams; therefore, velocities for discharges of 100,000, 200,000, and 300,000 cfs would be the same as in Plan 4. Plate 15 shows the velocities obtained for discharges of 400,000 cfs and above. The results indicated that flow conditions for the system were generally uniform and stable with turbulence only around the individual pilings. Velocities were generally uniform across the system and ranged from 3 to 6 fps, except along the right bank line. As in Plan 4, discharges above 400,000 cfs produced high scour velocities at the lower end of the system where the overbank flow reentered the channel. These velocities could be expected to be as high as 11 fps.

#### Plan 5A

24. Description. Plan 5A was the same as Plan 5 except the beams on rows 1, 3, 5, 7, and 9 were lowered to el 26.1 and the beams on rows 2, 4, 6, and 8 were lowered to el 13.2 (Plate 13). These elevations were chosen to match the tailwater elevations for the two lowest flows being tested.

25. Results. Water-surface elevations are shown in Table 4. The results indicated that the total head differential varied from 3.3 ft with the 100,000-cfs discharge to 7.9 ft with the 400,000-cfs discharge to 5.3 with the 650,000-cfs discharge. Flow conditions through the system were generally the

same as in Plans 4 and 5. Velocities (Plate 16) were generally uniform and ranged from 3 to 6 fps. As in the previous pile plans, scour velocities in the range of 11 fps can be expected where the overbank flow reenters the system from the right overbank for discharges above 400,000 cfs.

#### Plan 6

26. Description. Plan 6 was the same as Plan 4, except piles were removed from the system to form an opening for navigation. Preliminary testing was done to determine a satisfactory width of the opening. The width tested was 250 ft, normal to the piling rows and located near the left bank in the deepest section of the channel (Plate 13).

27. Results. Headwater and tailwater elevations are shown in Table 4. The results indicated that the headwater for each discharge would be less than in the previous plans and the head differentials would range from 1.7 to 4.6 ft. Flow conditions in the opening were uniform for the lower flows, but tended to become turbulent within the opening for the higher flows. Velocity measurements are shown in Plate 17. The results indicated the velocities would range from 3.3 to 15.0 fps in the opening, with the maximum velocities occurring at the downstream row of piles. Navigation through the opening was tested for discharges of 100,000 and 300,000 cfs using the model towboat. The tow had little to no trouble moving upstream through the opening, but could not navigate moving downstream. The velocities developed with the 400,000-cfs discharges and above were considered too high to permit navigation.

## PART V: LEFT DOWNSTREAM WING WALL REPLACEMENT

### Test Procedure

28. Evaluation of the feasibility of a rock replacement structure to replace the left downstream wing wall of the low-sill structure was made from visual observations and meter velocities at various points along the alignment of the wing wall. Meter velocities at 0.6 and bottom depths were obtained at 50-ft intervals along the existing wing wall and the toe of the slope of the replacement structure for a Mississippi River discharge of 1,775,000 cfs, the 1973 flood crest. The Old River discharge was 525,000 cfs with a headwater elevation of 58.2 and a tailwater elevation of 53.4.

### Test Results

#### Description

29. The replacement structure was a rock structure with 1V on 2H side slopes and a top elevation of 48 (Plate 18). The toe of the structure followed the alignment of the existing wing wall and the structure was tied into the left bank of the outflow channel to prevent an eddy from being formed behind the structure by flow around its end.

#### Results

30. Visual observations indicated that an eddy would occur beginning approximately 50 ft below the end of the south pier and extend for approximately 100 ft downstream for both the existing wing wall and the replacement structure. Plate 18 shows the meter velocities obtained for the existing wing wall and the replacement structure. The results indicated the maximum 0.6-depth velocity to be 13.3 cfs for the existing wing wall and 8.8 cfs for the replacement structure. The maximum bottom velocities obtained were 8.5 and 8.2 cfs, respectively. These results indicated the replacement structure would produce good flow patterns exiting the low-sill structure with velocities about the same or slightly lower than those with the existing wing wall.

## PART VI: DISCUSSION OF RESULTS AND CONCLUSIONS

### Limitations of Model Results

31. Analyses of the results of these investigations are based on a study of the effects of various conditions or modifications in the area of the low-sill structure on the current patterns and velocities and water-surface elevations in the outflow channel. In evaluating test results, it should be considered that small changes in the current patterns and velocities are not necessarily changes produced by the modification being tested because of pulsating currents or eddies or occasional slight wind gusts, since this is an outdoor model. In addition, flow patterns and velocities were based on steady flows and would be somewhat different when a hydrograph with rising and falling stages is considered. Meter velocities shown in the plates are average velocities obtained over a period of time with a cup meter. The meter velocities at bottom depth are indicative of velocities near the bottom, but not on the bottom because the design of the meters used will not permit a velocity to be obtained lower than approximately 5 ft (prototype) above the model bed. The small scale of the model made it difficult to measure water-surface elevations within an accuracy greater than  $\pm 0.1$  ft prototype. The model was of the fixed-bed type and was not designed to reproduce any sediment movement that might occur in the prototype; therefore, changes in the channel configurations resulting from scour and deposition were not reflected in the model results.

### Summary of Results and Conclusions

32. The following indications and conclusions were developed during the investigation:

- a. The closing of individual gates or combinations of gates to allow rehabilitation of the low-sill structure stilling basin would not produce excessive velocities at the structure end sill or adverse flow patterns in the outflow channel.
- b. Flow patterns in the outflow channel would be generally unaffected by the partial or complete rehabilitation of the low-sill structure stilling basin.
- c. Maximum velocities in the unprotected area of the outflow channel would occur for headwater river stages near 50 ft.
- d. Maximum velocities in the outflow channel would occur for

average to minimum Red River flow contributions. The velocities would be somewhat less for the maximum Red River contributions.

- e. The rock weir plans, Plans 1, 1A, 2, and 3, designed to control the low-sill structure tailwater would produce head differentials higher than desired and velocities too high to allow navigation through the weirs.
- f. The concrete piling plans, Plans 4, 5, and 5A, produced head differentials in the range generally desired; however, the pilings would block the outflow channel to navigation.
- g. Using concrete pilings with a 250-ft navigation opening, Plan 6, would produce head differentials less than with Plans 4, 5, and 5A. Velocities in the navigation opening for discharges below 300,000 cfs would permit navigation upstream, but downstream navigation would be hazardous. For discharges above 300,000 cfs, navigation would be too hazardous in either direction.
- h. The replacement of the left downstream wing wall of the low-sill structure with a stone dike produced good flow patterns with velocities along the dike somewhat less than those along the existing wing wall.

Table 1  
Stilling Basin Rehabilitation  
Gate Closure Test  
Mississippi River Discharge 200,000 cfs

<u>Gates Closed</u>	<u>Old River Discharge, cfs</u>	<u>Headwater El</u>	<u>Tailwater El</u>	<u>Head Differential, ft</u>
All open (Base)	69,000	15.2	5.9	9.3
1	62,000	15.6	6.2	9.4
2	62,000	15.5	6.1	9.4
3	62,000	15.6	6.1	9.5
4	62,000	15.5	6.2	9.3
5	59,000	16.1	5.5	10.6
6	59,000	16.0	5.3	10.7
7	59,000	15.9	5.3	9.4
8	70,000	15.5	6.1	9.4
9	70,000	15.5	6.1	9.4
10	70,000	15.5	6.1	9.4
11	70,000	15.5	6.2	9.3
1,2	67,000	15.8	6.0	9.8
2,3	67,000	15.8	5.9	9.9
3,4	68,000	15.9	5.8	10.1
4,5	59,000	16.1	4.9	11.2
5,6	48,000	16.4	3.6	12.8
6,7	48,000	16.6	4.2	12.4
7,8	58,000	16.1	4.8	11.3
8,9	63,000	15.6	5.7	9.9
9,10	63,000	15.4	5.5	9.9
10,11	63,000	15.5	5.8	9.7
2,3,4	67,000	16.0	5.9	9.9
3,4,5	55,000	16.1	4.7	11.4
4,5,6	43,000	16.2	3.0	13.2
5,6,7	38,000	16.4	2.2	14.2
6,7,8	40,000	16.2	3.0	13.2
7,8,9	48,000	15.1	4.6	10.5
8,9,10	59,000	15.9	5.8	10.1
9,10,11	66,000	15.8	6.0	9.8
2,3,4,5	56,000	16.2	4.4	11.8
3,4,5,6	40,000	16.4	3.0	13.4
4,5,6,7	35,000	16.5	1.0	15.5
5,6,7,8	35,000	16.4	1.1	15.3
6,7,8,9	40,000	16.3	2.9	13.4
7,8,9,10	49,000	16.1	4.3	11.8
2,3,4,5,6	45,000	16.6	3.0	13.6
6,7,8,9,10	40,000	16.3	2.5	13.8

Table 2  
Low-Sill Structure Tailwater Control  
Rock Weir Test  
Plan 2 Water-Surface Elevations

Gage	Old River Discharge, cfs				
	100,000	160,000	237,000	315,000	380,000
Weir headwater	15.3	25.3	33.3	39.3	43.6
Between weirs 1 & 2	14.2	23.6	30.8	36.8	40.5
Between weirs 2 & 3	14.2	23.6	30.6	36.7	40.5
Between weirs 3 & 4	14.0	23.2	30.5	36.4	40.5
Between weirs 4 & 5	13.6	23.1	30.2	35.7	40.0
Between weirs 5 & 6	13.2	22.8	30.0	35.6	40.0
Between weirs 6 & 7	13.2	22.8	29.8	35.5	40.0
Weir tailwater*	13.0	22.3	28.8	34.5	38.8

\* Control gage.

Table 3  
Low-Sill Structure Tailwater Control  
Rock Weir Test  
Plan 3 Water-Surface Elevations

Gage	Old River Discharge, cfs					
	100,000	237,000	315,000	380,000	500,000	600,000
Weir 1						
Headwater	17.8	35.5	41.2	45.5	49.8	52.8
Tailwater	16.9	34.1	39.8	43.8	48.0	51.6
Weir 2						
Headwater	16.9	33.9	39.7	43.8	47.8	51.6
Tailwater	16.3	32.6	38.3	42.8	47.6	51.3
Weir 3						
Headwater	16.2	32.3	38.0	42.8	47.6	51.3
Tailwater	15.1	31.0	37.0	41.8	46.9	50.9
Weir 4						
Headwater	14.9	30.7	36.9	41.5	46.8	50.9
Tailwater	14.1	29.7	35.4	40.3	46.2	50.5
Weir 5						
Headwater	14.0	29.5	35.2	40.0	46.2	50.5
Tailwater*	13.0	28.8	34.5	38.8	45.7	49.1

\* Control gage.

Table 4

Low-Sill Structure Tailwater Control

Concrete Pile Test

Plans 4, 5, 5A, and 6 Water-Surface Elevations

Discharge cfs	Plan 4 (No Beams)		Plan 5 (Top of Beams at El 48.0 and 50.0)		Plan 5A (Top of Beams at El 13.2 and 26.1)		Plan 6 (250-ft Navigation Opening)	
	Headwater	Tailwater*	Headwater	Tailwater*	Headwater	Tailwater*	Headwater	Tailwater*
100,000	15.8	13.0	15.8	13.0	16.5	13.2	14.7	13.0
200,000	30.6	26.1	30.6	26.1	31.9	26.0	29.7	26.1
300,000	40.1	33.6	40.1	33.6	41.0	33.6	36.8	33.6
400,000	47.0	40.2	47.2	40.1	48.1	40.2	44.3	40.2
500,000	51.5	45.8	52.2	46.0	52.4	45.8	50.4	45.8
600,000	54.4	49.1	54.5	49.2	54.6	49.0	52.9	49.1
650,000	54.8	50.0	55.2	50.0	55.3	50.0	54.1	50.0

\* Control gage.

Table 5  
Low-Sill Structure Tailwater Control  
Concrete Pile Test  
Plan 4 Water-Surface Elevations

<u>Gage</u>	<u>Discharge, cfs</u>			
	<u>100,000</u>	<u>200,000</u>	<u>300,000</u>	<u>400,000</u>
Headwater	15.8	30.6	40.1	47.0
Between rows 1 and 2	15.4	30.2	39.6	46.2
Between rows 2 and 3	15.3	29.7	38.8	45.8
Between rows 3 and 4	14.8	29.2	38.7	45.3
Between rows 4 and 5	14.8	28.9	37.8	44.5
Between rows 5 and 6	14.5	28.6	37.0	43.8
Between rows 6 and 7	14.0	27.5	36.8	43.1
Between rows 7 and 8	13.7	26.5	36.0	42.2
Between rows 8 and 9	13.2	26.3	34.9	41.2
Tailwater*	13.0	26.1	33.6	10.2

\* Control gage.



Photo 1. Stilling basin rehabilitation test, current patterns below low-sill structure. Mississippi River discharge 395,000 cfs, all gates in orifice mode. No repair. Head-water el 28.0. Tailwater el 16.0. Old River discharge 100,000 cfs.



Photo 2. Stilling basin rehabilitation test, current patterns below low-sill structure. Mississippi River discharge 1,150,000 cfs, all gates in orifice mode. No repair. Headwater el 52.0. Tailwater el 37.2. Old River discharge 258,000 cfs.



Photo 3. Stilling basin rehabilitation test, current patterns below low-sill structure. Mississippi River discharge 395,000 cfs, all gates in orifice mode. Fully repaired. Headwater el 28.0. Tailwater el 16.0. Old River discharge 100,000 cfs.

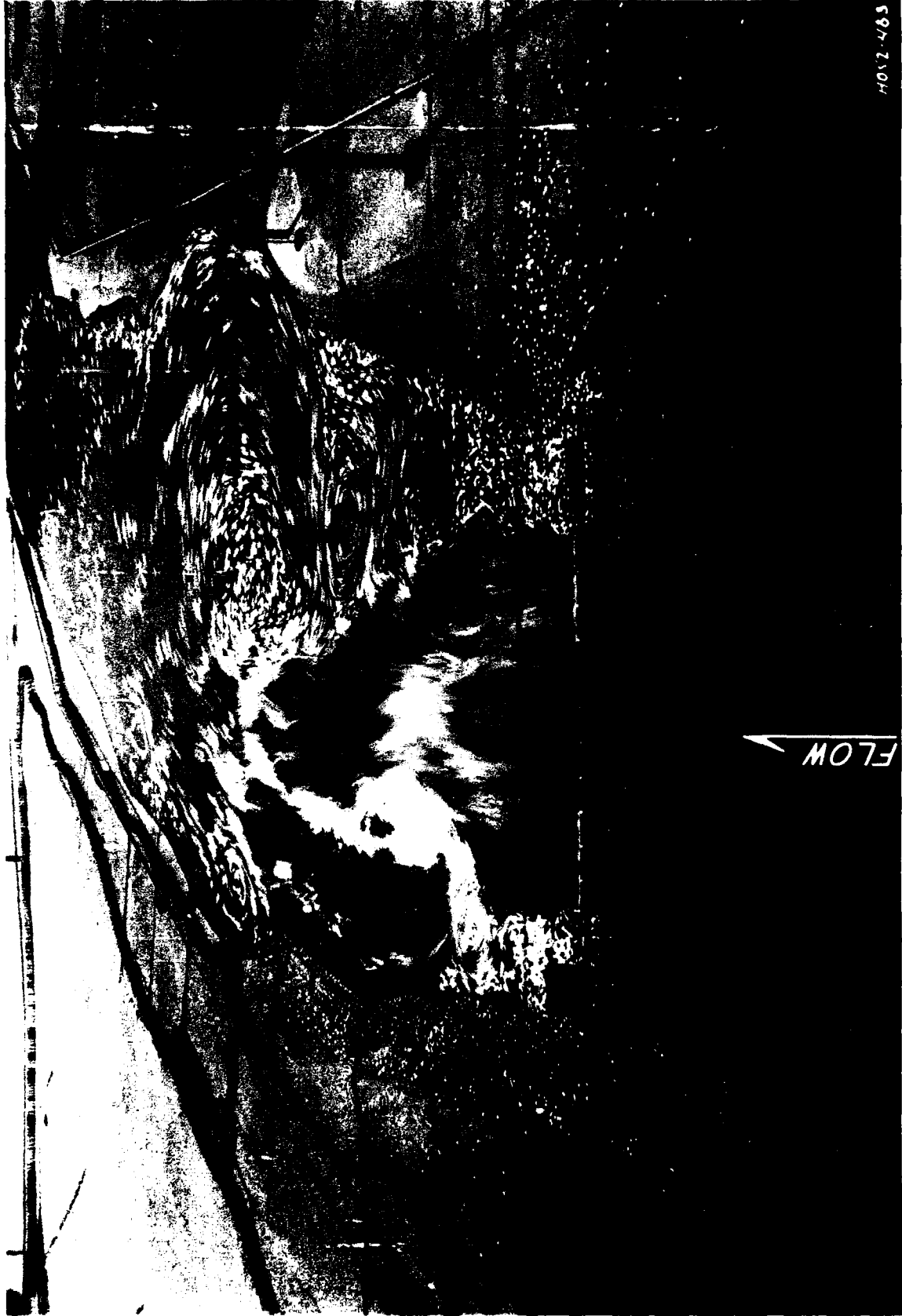
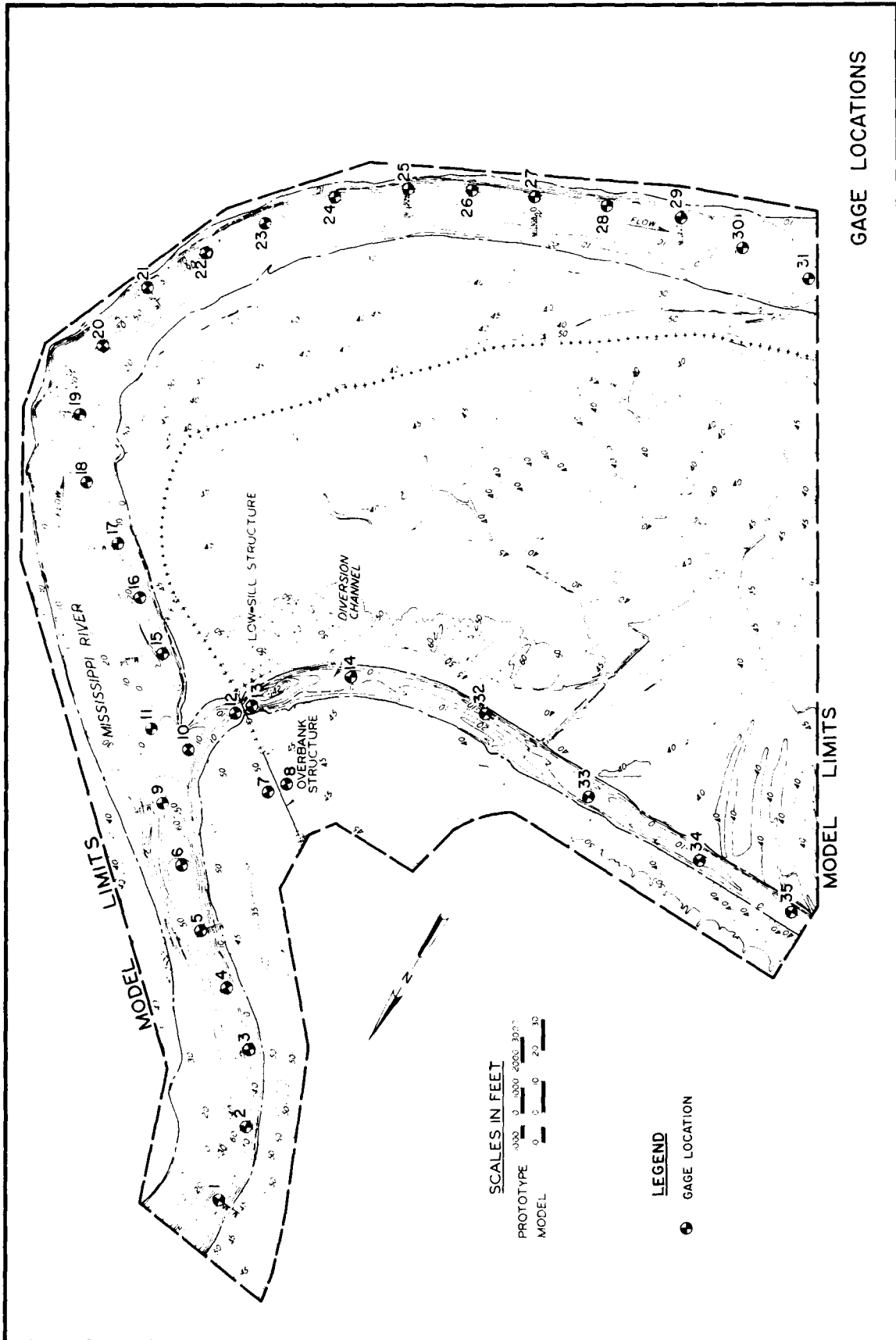

Photo 4. Stilling basin rehabilitation test, current patterns below low-sill structure Mississippi River discharge 1,150,000 cfs, all gates in orifice mode. Fully repaired. Headwater el 52.0. Tailwater el 37.2. Old River discharge 258,000 cfs.



GAGE LOCATIONS

MODEL LIMITS

SCALES IN FEET

PROTOTYPE 0 1000 2000 3000  
 MODEL 0 10 20 30

LEGEND

● GAGE LOCATION

DISCHARGE 69,000 CFS  
 HEADWATER EL 15.2  
 TAILWATER EL 5.9

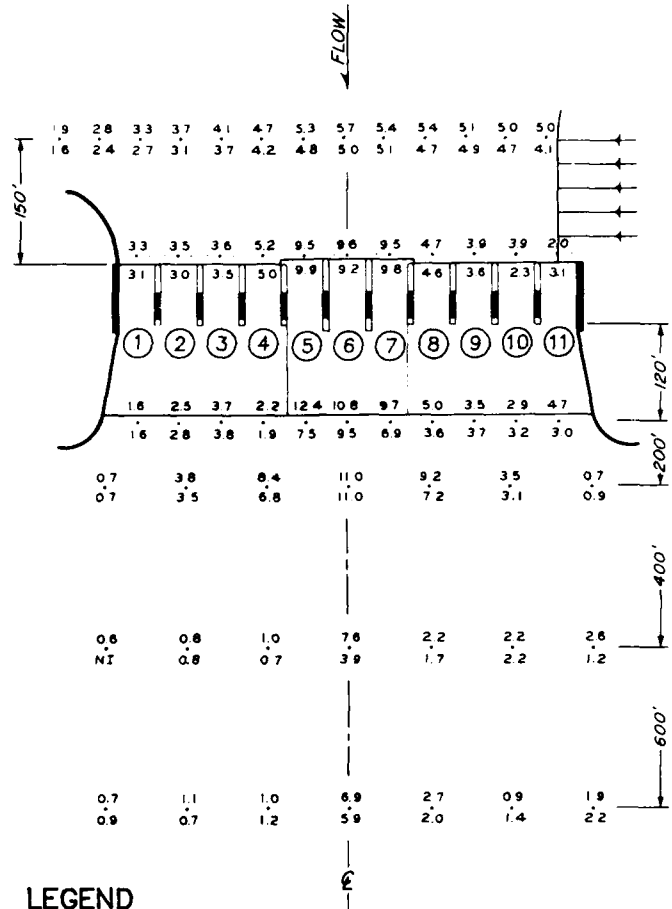

**LEGEND**

- 9.6 VELOCITY AT 0.6 DEPTH
- 5.3 VELOCITY AT BOTTOM DEPTH
- ② LOW-SILL STRUCTURE GATE NUMBER

NOTE: VELOCITIES ARE IN PROTOTYPE FEET PER SECOND

ELEVATIONS ARE IN FEET REFERRED TO NGVD

**STILLING BASIN REHABILITATION TESTS**

POINT VELOCITIES  
 BASE - ALL GATES OPEN

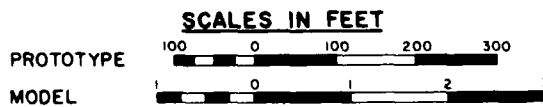

DISCHARGE 40,000 CFS  
 HEADWATER EL 16.3  
 TAILWATER EL 2.5

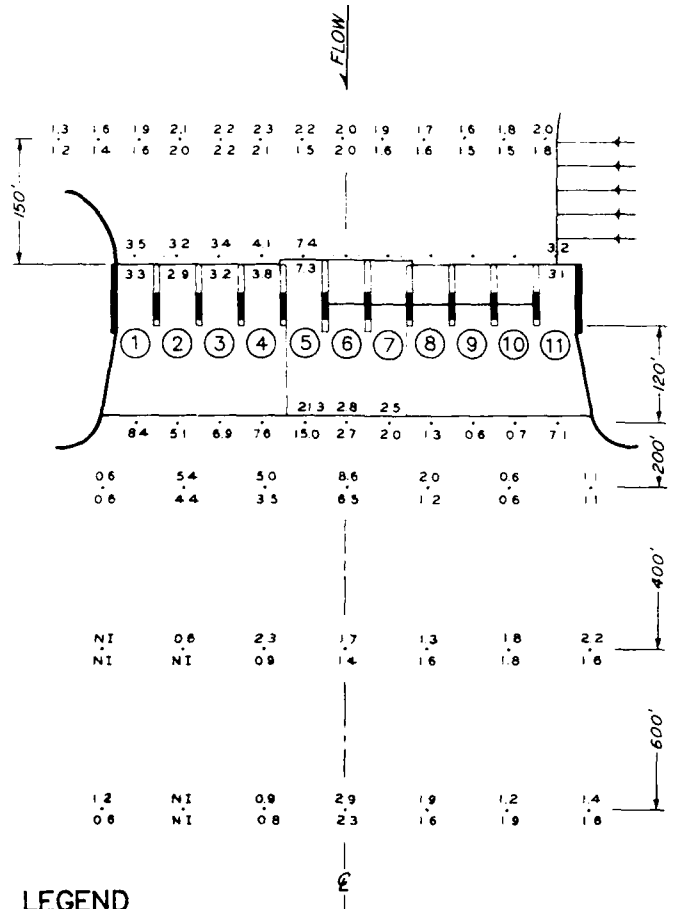

**LEGEND**

- 9.6 VELOCITY AT 0.6 DEPTH
- 5.3 VELOCITY AT BOTTOM DEPTH
- ② LOW-SILL STRUCTURE GATE NUMBER

NOTE: VELOCITIES ARE IN PROTOTYPE FEET PER SECOND

ELEVATIONS ARE IN FEET REFERRED TO NGVD

**SCALES IN FEET**

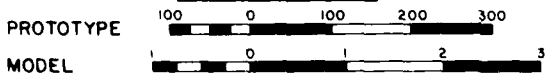

**STILLING BASIN REHABILITATION TESTS**

POINT VELOCITIES  
 GATES 6, 7, 8, 9, & 10 CLOSED

DISCHARGE 67,000 CFS  
 HEADWATER EL 15.8  
 TAILWATER EL 5.9

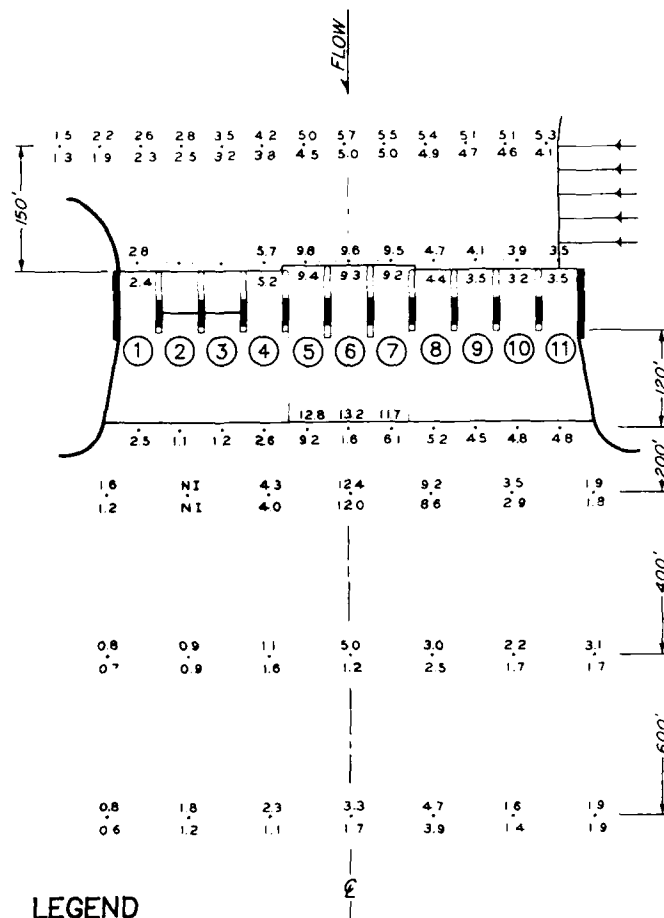

**LEGEND**

- 9.6 VELOCITY AT 0.6 DEPTH
- 5.3 VELOCITY AT BOTTOM DEPTH
- ② LOW-SILL STRUCTURE GATE NUMBER

NOTE: VELOCITIES ARE IN PROTOTYPE FEET PER SECOND

ELEVATIONS ARE IN FEET REFERRED TO NGVD

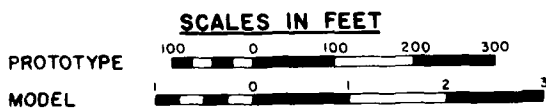

**STILLING BASIN  
 REHABILITATION TESTS**  
 POINT VELOCITIES  
 GATES 2 AND 3 CLOSED

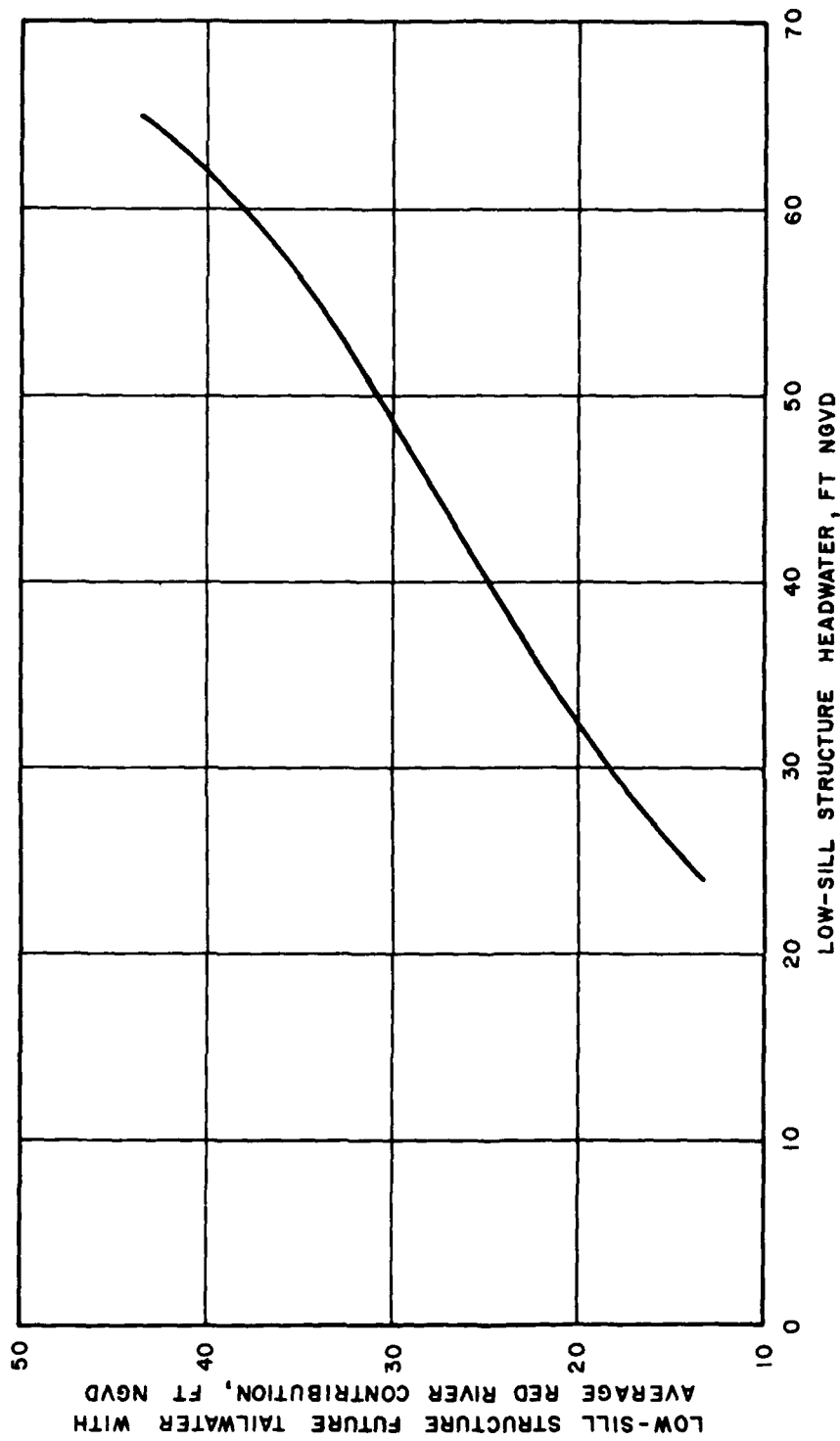

**FUTURE TAILWATER CONDITIONS**  
**SCOUR PROTECTION TESTS**

GATES 1-4 & 8-11 AT 1928 FT  
GATES 5-7 AT 2486 FT

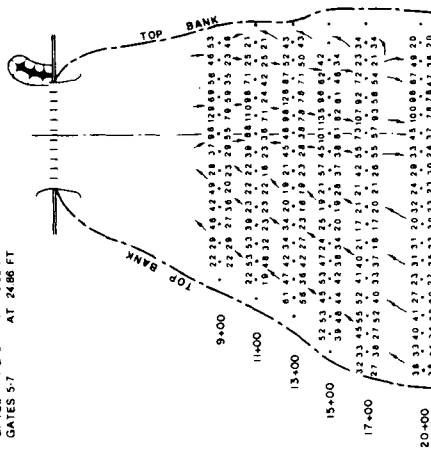

MISSISSIPPI DISCHARGE 1,006,000 CFS  
OLD RIVER DISCHARGE 302,000 CFS  
HEADWATER EL 48.0  
TAILWATER EL 29.5

GATES 1-4 & 8-11 AT 1928 FT  
GATES 5-7 AT 1465 FT

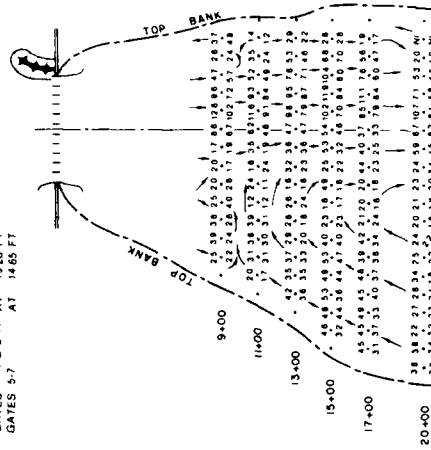

MISSISSIPPI DISCHARGE 1,150,000 CFS  
OLD RIVER DISCHARGE 310,000 CFS  
HEADWATER EL 52.0  
TAILWATER EL 31.8

**LEGEND**

- 4.4 VELOCITY OBTAINED AT 0.6 DEPTH
- 2.2 VELOCITY OBTAINED AT BOTTOM DEPTH
- ~ DIRECTION OF FLOW
- NI NO INDICATION OF VELOCITY

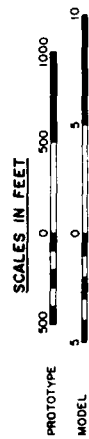

**OUTFLOW CHANNEL SCOUR PROTECTION**  
**POINT VELOCITIES**  
**48- AND 52-FT STAGES**

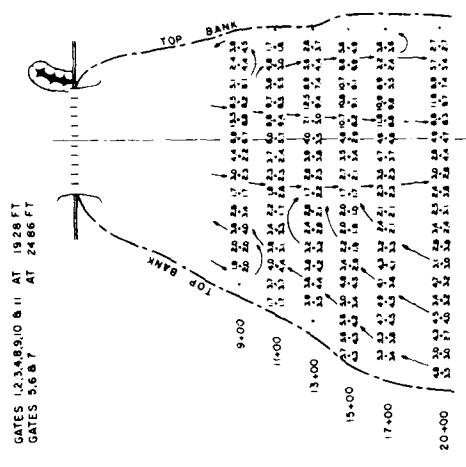
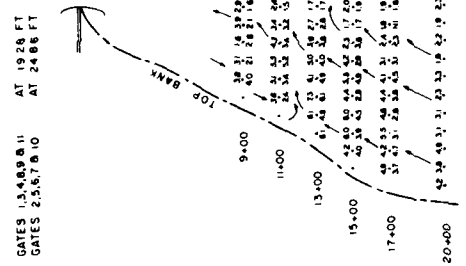
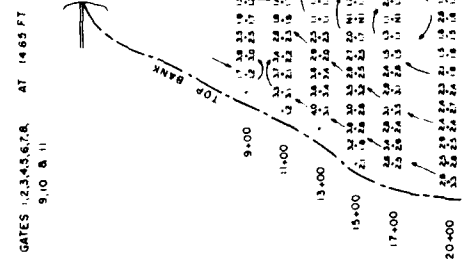

MAXIMUM RED RIVER DISCHARGE

MINIMUM RED RIVER DISCHARGE

AVERAGE RED RIVER DISCHARGE

**LEGEND**

- 4.4 VELOCITY OBTAINED AT 0.6 DEPTH
- 2.2 VELOCITY OBTAINED AT BOTTOM DEPTH
- ~ DIRECTION OF FLOW

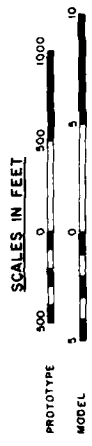

**OUTFLOW CHANNEL SCOUR PROTECTION**  
**POINT VELOCITIES**  
**RED RIVER DISCHARGES**

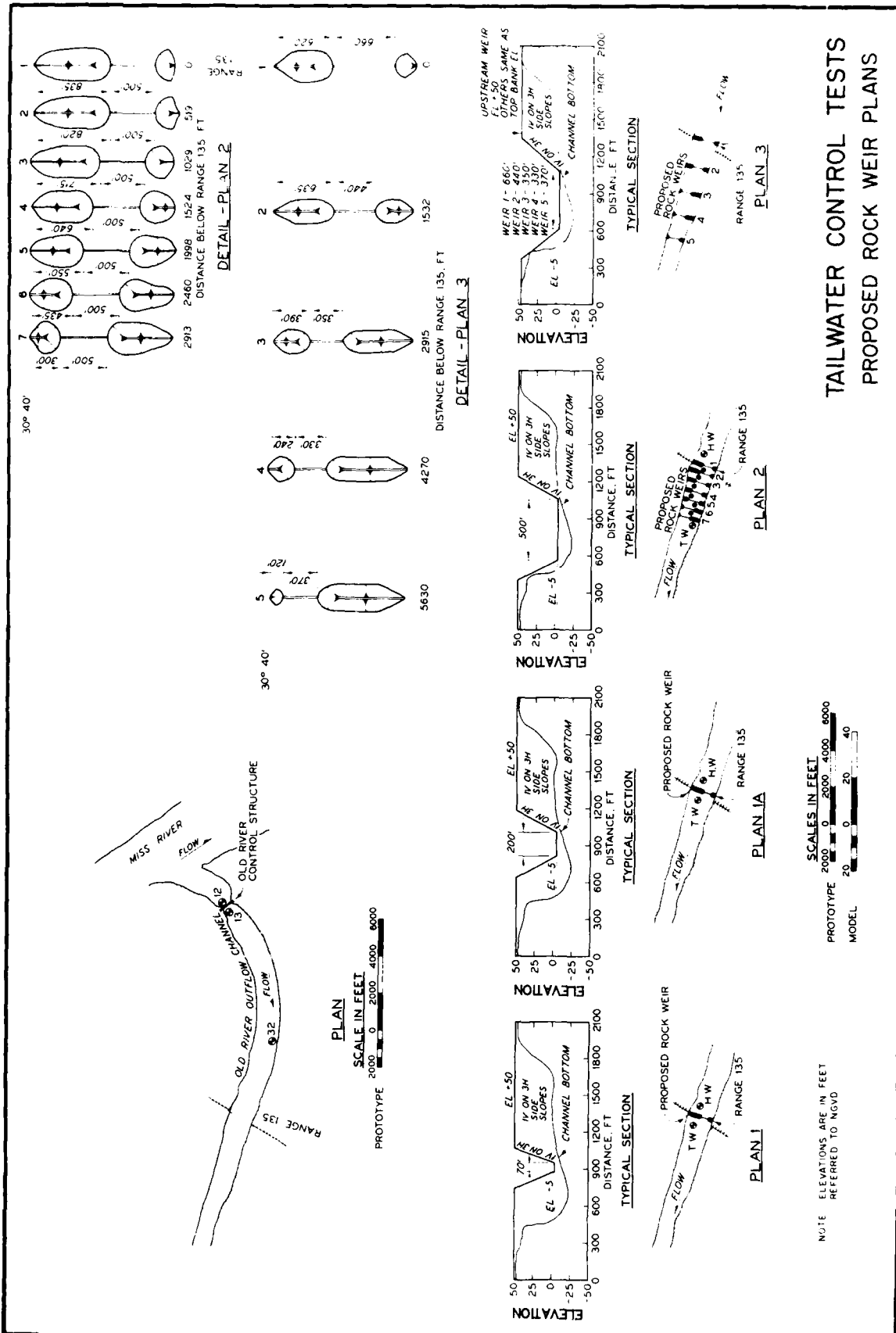

**TAILWATER CONTROL TESTS  
PROPOSED ROCK WEIR PLANS**

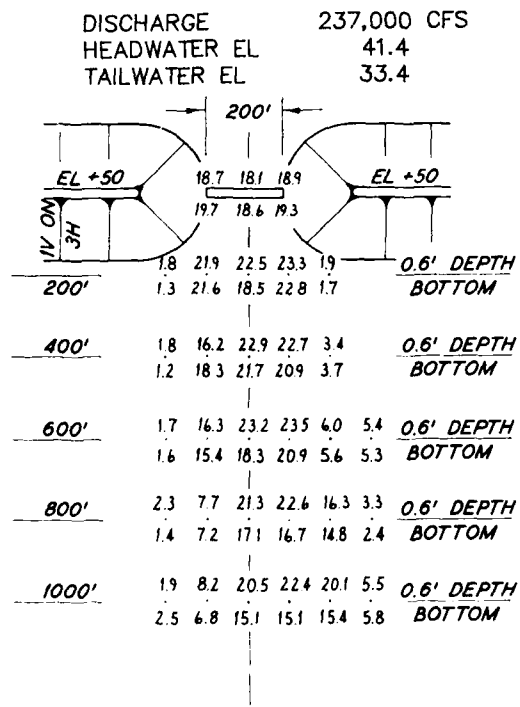
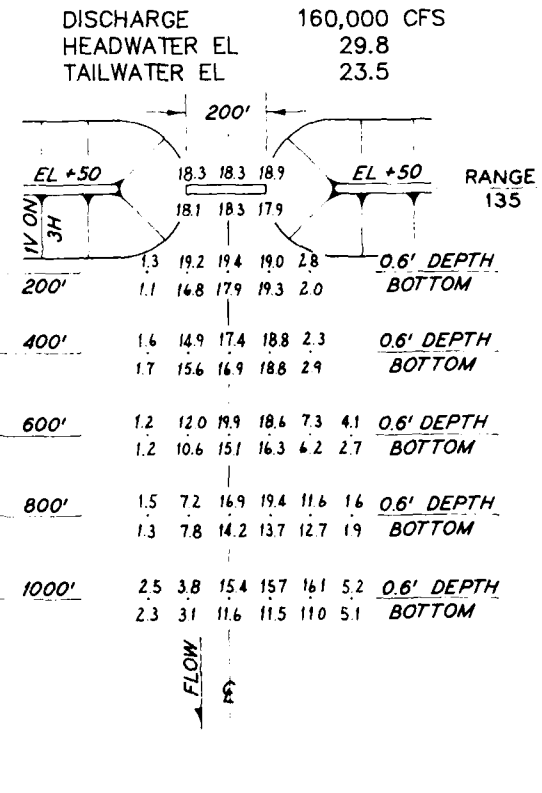
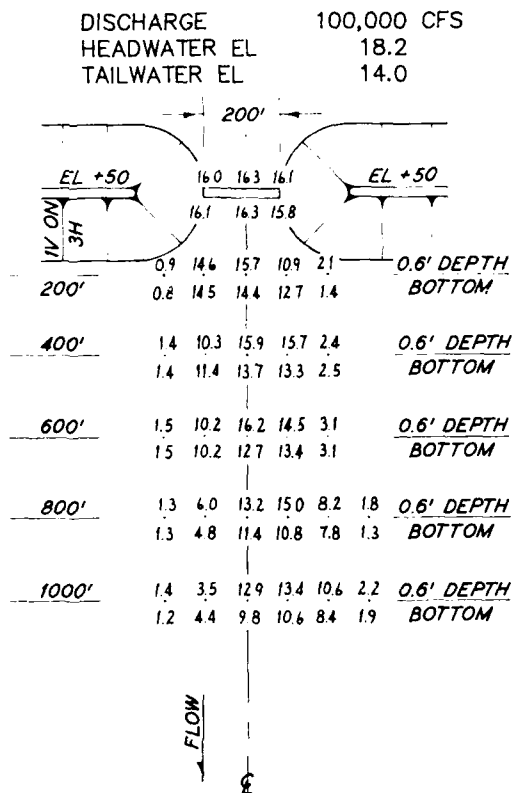

NOTE: VELOCITIES ARE IN PROTOTYPE FEET PER SECOND  
ELEVATIONS ARE IN FEET REFERRED TO NGVD

**TAILWATER CONTROL TESTS  
PLAN 1A  
VELOCITIES THROUGH AND  
BELOW WEIR**

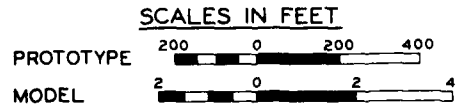

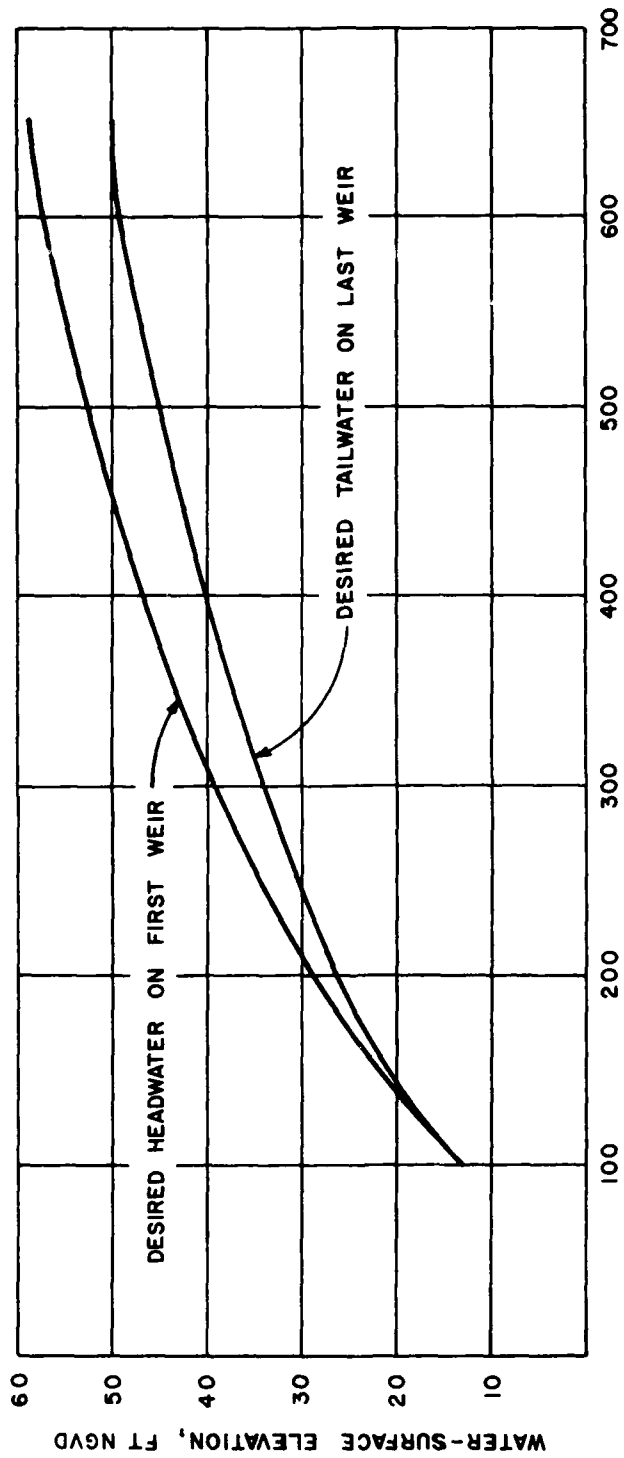

DISCHARGE THROUGH THE OLD RIVER CONTROL STRUCTURES, 1,000 CFS

DESIRED HEADWATER-TAILWATER RELATIONSHIP

ROCK WEIR PLANS 2 AND 3

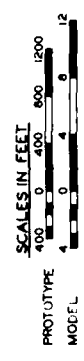
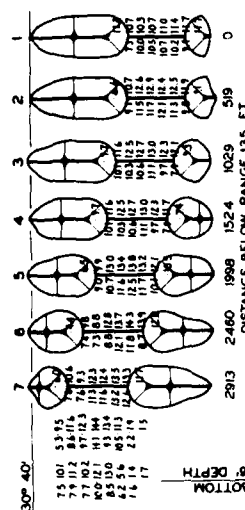
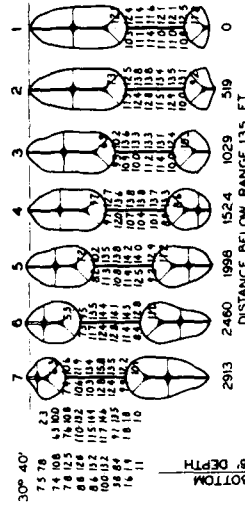
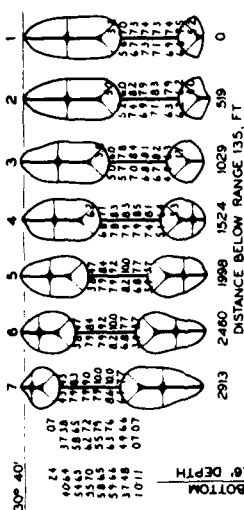
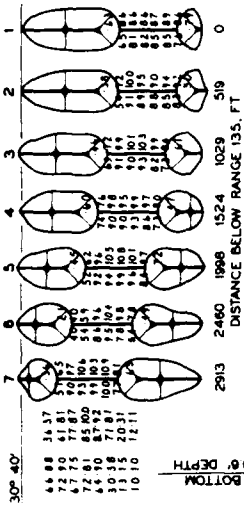
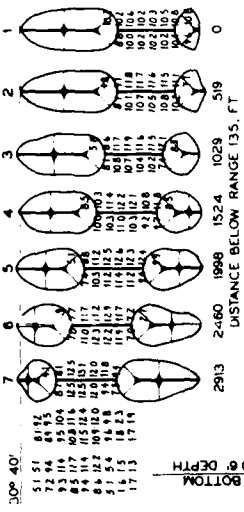

TAILWATER CONTROL TESTS  
 PLAN 2

NOTE: VELOCITIES ARE IN PROTOTYPE FEET PER SECOND  
 ELEVATIONS ARE IN FEET REFERRED TO NGVD

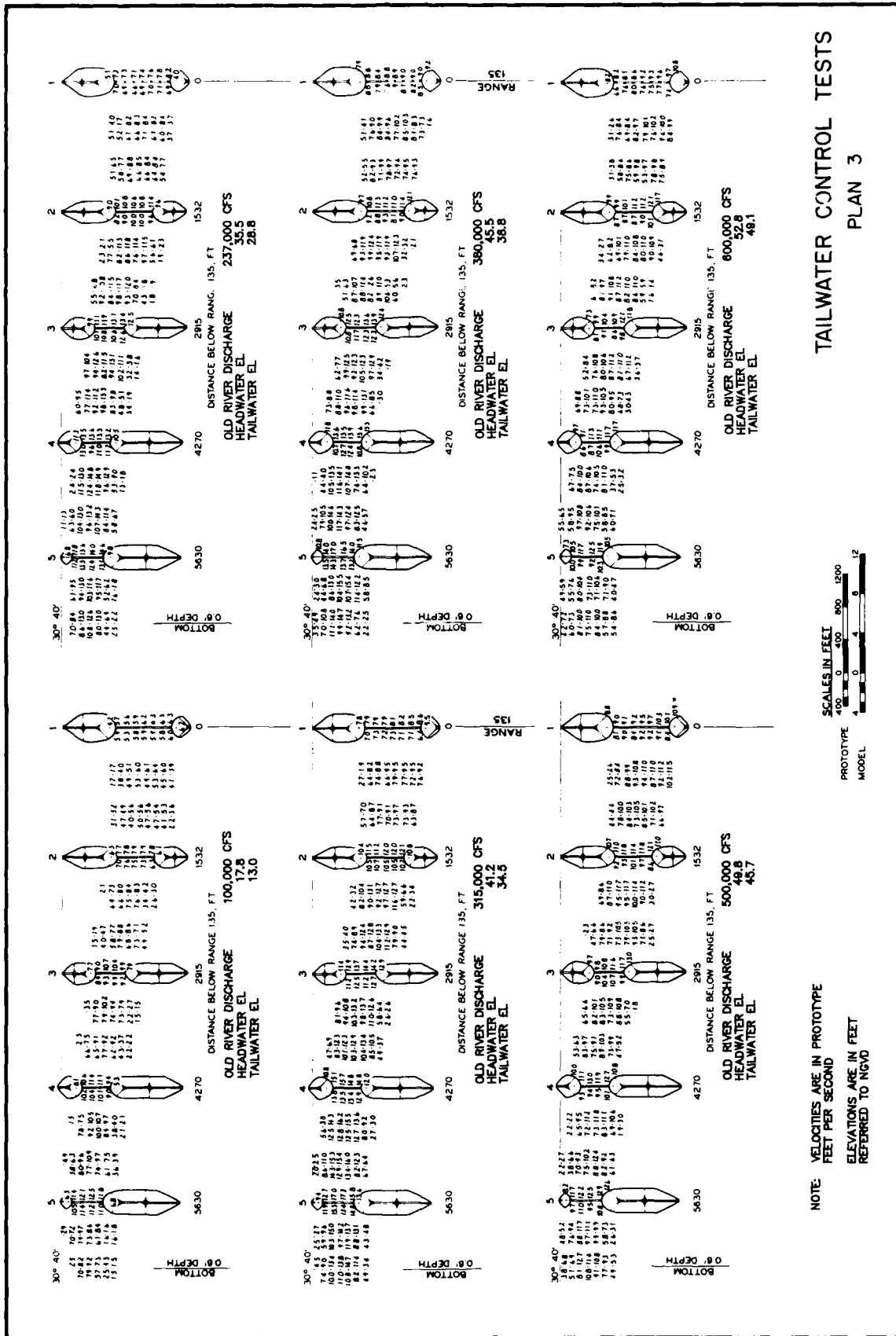

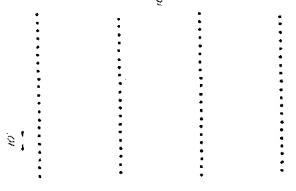

DETAIL - PILE SPACINGS  
SCALE IN FEET  
PROTOTYPE 40' 0" 40' 0"

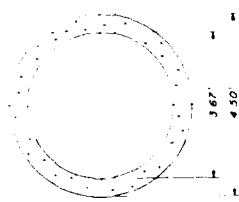

DETAIL - PILE CROSS-SECTION  
SCALE IN FEET  
PROTOTYPE 0 1 2

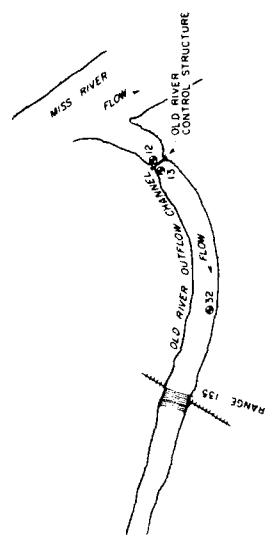

PLAN  
SCALE IN FEET  
PROTOTYPE 0 500 1000 2000

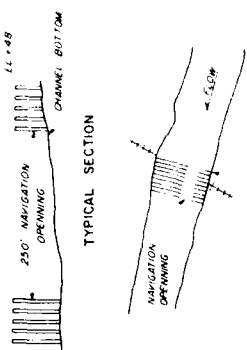

TYPICAL SECTION  
PLAN 6

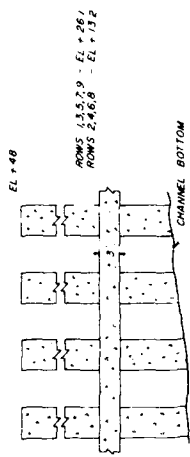

TYPICAL SECTION  
PLAN 5A

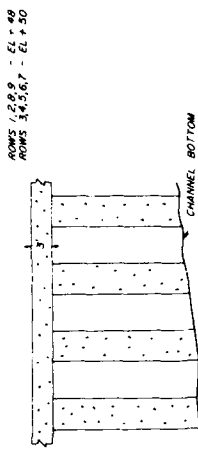

TYPICAL SECTION  
PLAN 5

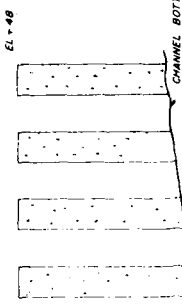

TYPICAL SECTION  
PLAN 4

TAILWATER CONTROL TESTS  
PROPOSED CONCRETE PILE PLANS

NOTE: ELEVATIONS ARE IN FEET  
REFERRED TO NGVD

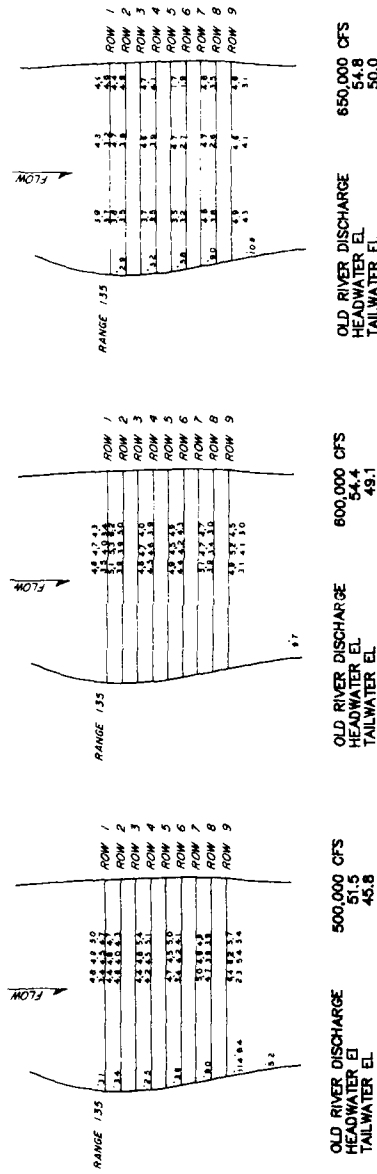
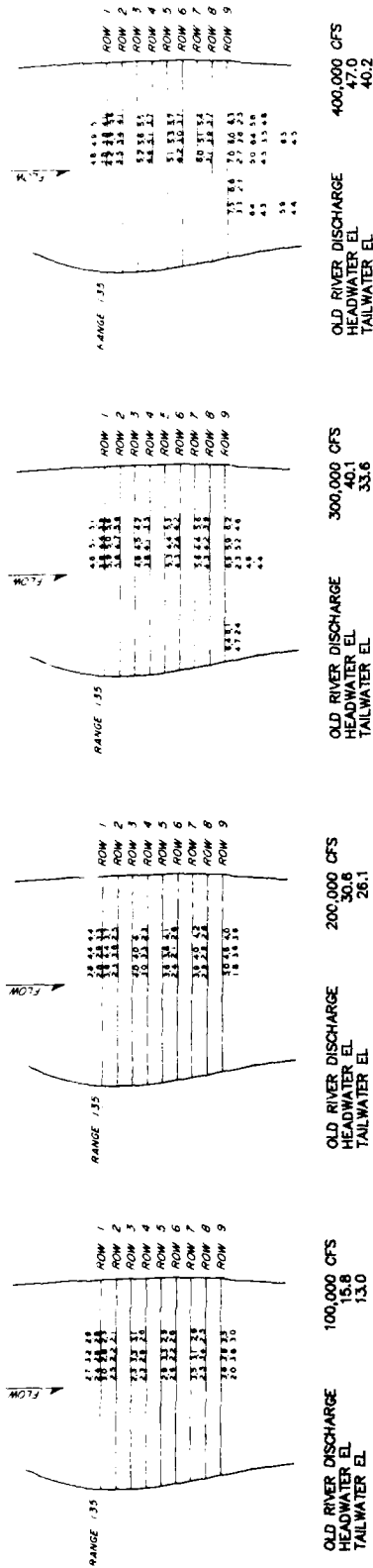

LEGEND

- 7.8 VELOCITY OBTAINED AT 0.6 DEPTH
- 5.6 VELOCITY OBTAINED AT BOTTOM DEPTH

NOTE: VELOCITIES ARE IN PROTOTYPE FEET PER SECOND  
ELEVATIONS ARE IN FEET REFERRED TO NGVD

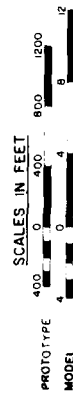

TAILWATER CONTROL TESTS  
PLAN 4

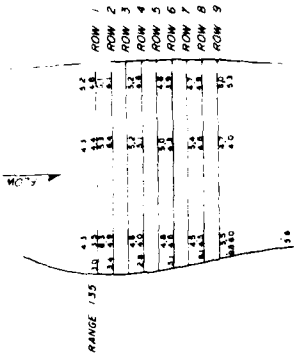

500,000 CFS  
 HEADWATER EL. 52.2  
 TAILWATER EL. 46.0

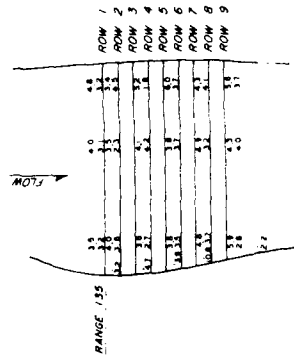

650,000 CFS  
 HEADWATER EL. 52.2  
 TAILWATER EL. 50.0

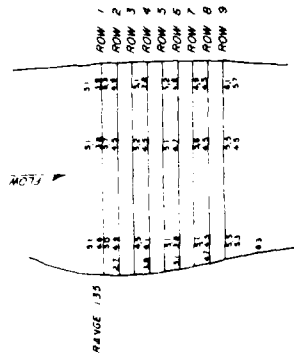

400,000 CFS  
 HEADWATER EL. 47.2  
 TAILWATER EL. 40.1

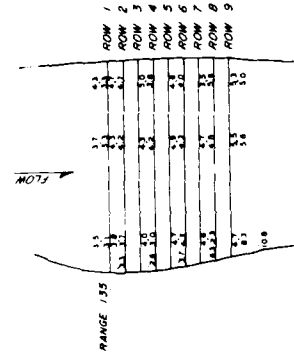

600,000 CFS  
 HEADWATER EL. 54.5  
 TAILWATER EL. 48.2

**LEGEND**

- 7.8 VELOCITY OBTAINED AT 0.6 DEPTH
- 5.6 VELOCITY OBTAINED AT BOTTOM DEPTH

NOTE: VELOCITIES ARE IN PROTOTYPE FEET PER SECOND  
 ELEVATIONS ARE IN FEET REFERRED TO NGVD

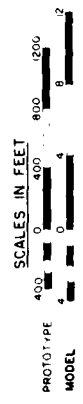

**TAILWATER CONTROL TESTS**  
**PLAN 5**

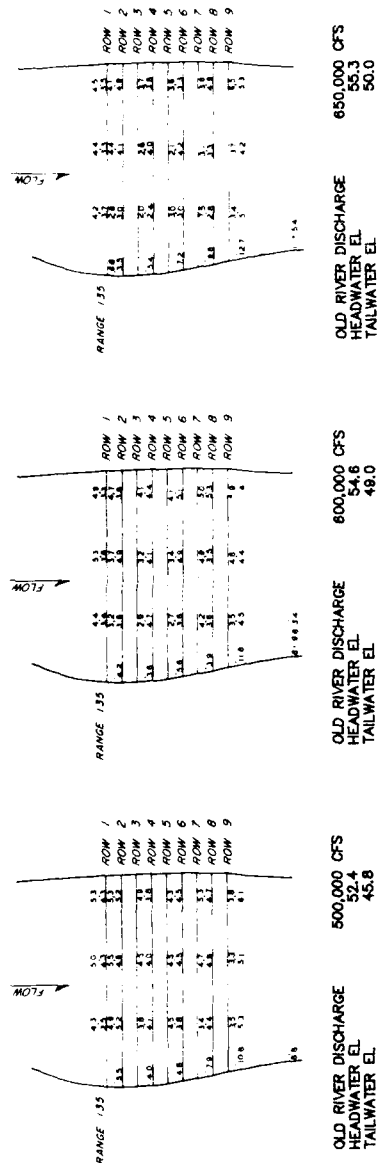
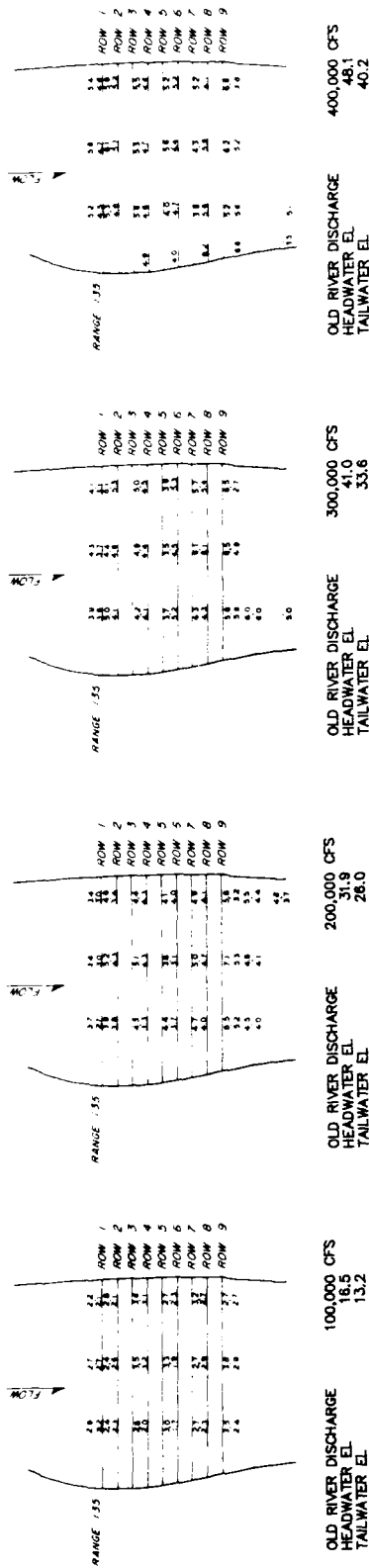

**LEGEND**

- 7.8 VELOCITY OBTAINED AT 0.6 DEPTH
- 5.6 VELOCITY OBTAINED AT BOTTOM DEPTH

NOTE: VELOCITIES ARE IN PROTOTYPE FEET PER SECOND  
ELEVATIONS ARE IN FEET REFERRED TO NGVD

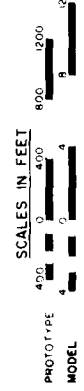

**TAILWATER CONTROL TESTS**  
PLAN 5A

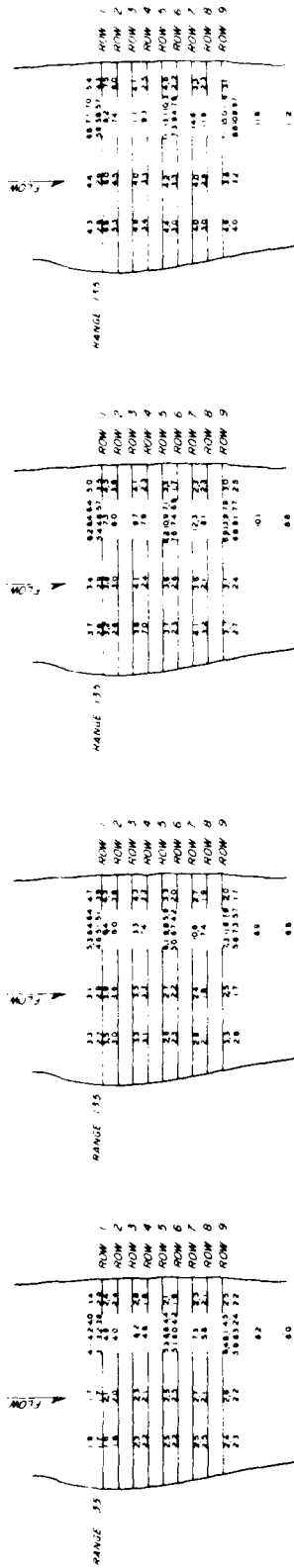

OLD RIVER DISCHARGE HEADWATER EL. TAILWATER EL.

100,000 CFS	14.7	13.0
200,000 CFS	29.1	26.1
300,000 CFS	36.8	33.6
400,000 CFS	44.3	40.2
500,000 CFS	54.1	50.0

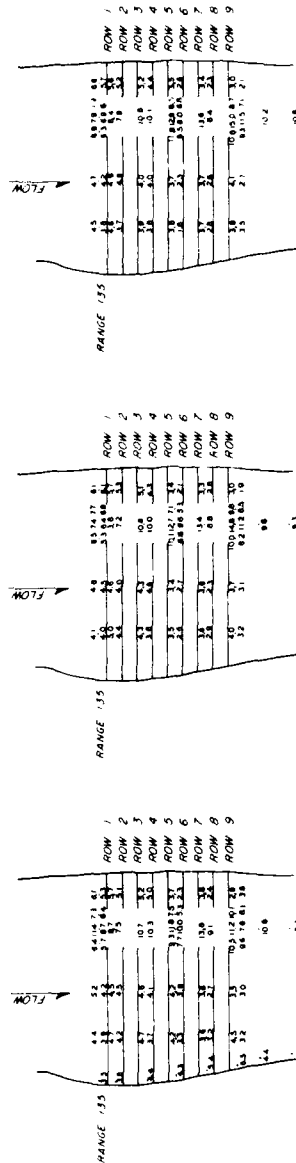

OLD RIVER DISCHARGE HEADWATER EL. TAILWATER EL.

600,000 CFS	52.9	49.1
650,000 CFS	54.1	50.0
700,000 CFS	55.1	51.0
750,000 CFS	56.1	52.0
800,000 CFS	57.1	53.0

**LEGEND**

- 7.8 VELOCITY OBTAINED AT 0.8 DEPTH
- 5.6 VELOCITY OBTAINED AT BOTTOM DEPTH

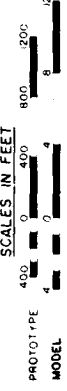

NOTE: VELOCITIES ARE IN PROTOTYPE FEET PER SECOND  
 ELEVATIONS ARE IN FEET REFERRED TO NGVD

**TAILWATER CONTROL TESTS**  
**PLAN 6**

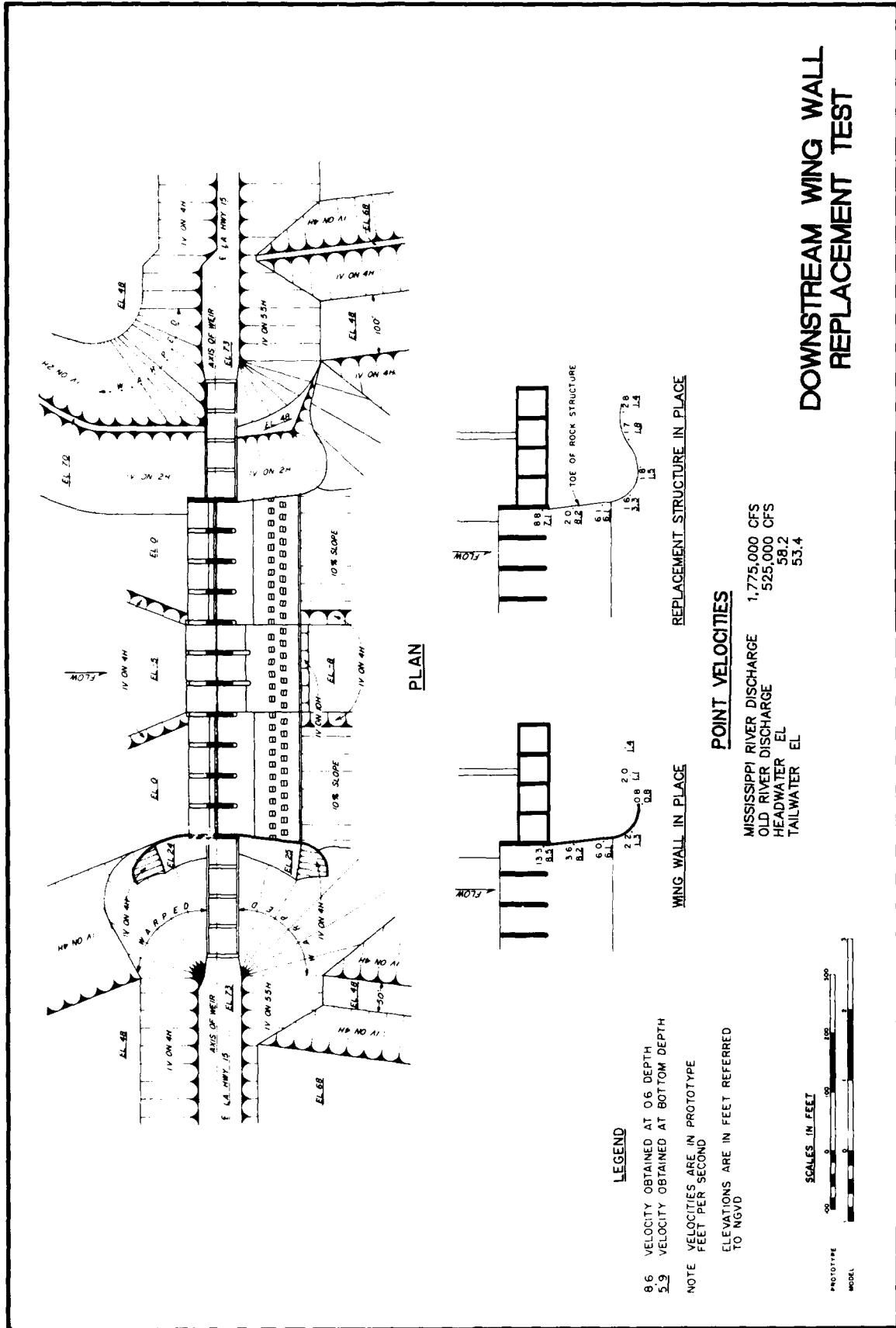

PLAN

**LEGEND**  
 8.6 VELOCITY OBTAINED AT 0.6 DEPTH  
 5.9 VELOCITY OBTAINED AT BOTTOM DEPTH  
 NOTE VELOCITIES ARE IN PROTOTYPE  
 FEET PER SECOND  
 ELEVATIONS ARE IN FEET REFERRED  
 TO NGVD

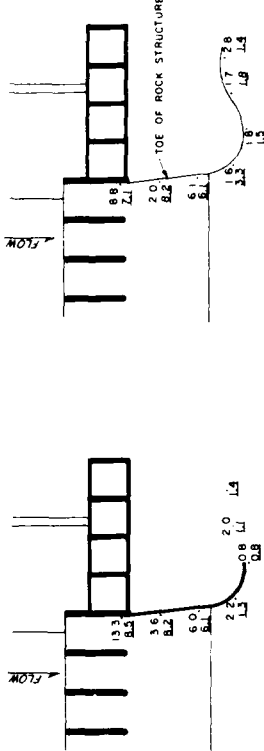

WING WALL IN PLACE

REPLACEMENT STRUCTURE IN PLACE

**POINT VELOCITIES**

MISSISSIPPI RIVER DISCHARGE	1,775,000 CFS
OLD RIVER DISCHARGE	525,000 CFS
HEADWATER EL	58.2
TAILWATER EL	53.4

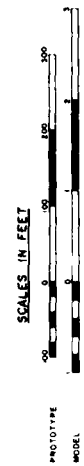

**DOWNSTREAM WING WALL  
 REPLACEMENT TEST**