

AD-A207 155

FINAL REPORT
February 1988

REPORT NO. EVT-48-87 ✓

MIL-STD-1660 TEST
OF UNITIZATION PROCEDURE
FOR ARMOR TILE, M1 AND M2,
PACKED IN WOODEN BOXES

SDTIC
ELECTE
APR 25 1989
E D

Prepared for:
U.S. Army Armament, Munitions
and Chemical Command
ATTN: SMCAR-ESK
Rock Island, IL 61299-7300

Distribution Unlimited

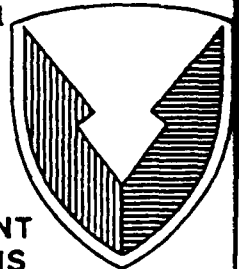

US ARMY
ARMAMENT
MUNITIONS
CHEMICAL COMMAND

US ARMY DEFENSE AMMUNITION
CENTER AND SCHOOL

EVALUATION DIVISION
SAVANNA, ILLINOIS 61074-9639

25 038

AVAILABILITY NOTICE

A copy of this report is furnished each attendee on automatic distribution. Additional copies or authority for reprinting may be obtained by written request from Director, U.S. Army Defense Ammunition Center and School.
ATTN: SMCAC-DEV, Savanna, IL 61074-9639.

DISTRIBUTION INSTRUCTIONS

Destroy this report when no longer needed. Do not return.

* * *

Citation of trade names in this report does not constitute an official endorsement.

* * *

The information contained herein will not be used for advertising purposes.

UNCLASSIFIED

SECURITY CLASSIFICATION OF THIS PAGE

REPORT DOCUMENTATION PAGE				Form Approved OMB No. 0704-0188	
1a. REPORT SECURITY CLASSIFICATION UNCLASSIFIED		1b. RESTRICTIVE MARKINGS			
2a. SECURITY CLASSIFICATION AUTHORITY		3. DISTRIBUTION/AVAILABILITY OF REPORT			
2b. DECLASSIFICATION/DOWNGRADING SCHEDULE		UNLIMITED			
4. PERFORMING ORGANIZATION REPORT NUMBER(S) EVT 48-87		5. MONITORING ORGANIZATION REPORT NUMBER(S)			
6a. NAME OF PERFORMING ORGANIZATION U.S. Army Defense Ammunition Center and School		6b. OFFICE SYMBOL (if applicable) SMCAC-DEV	7a. NAME OF MONITORING ORGANIZATION Storage and Outloading Division U.S. Army Defense Ammunition Center and School		
6c. ADDRESS (City, State, and ZIP Code) Savanna, IL 61074-9639		7b. ADDRESS (City, State, and ZIP Code) ATTN: SMCAC-DEO Savanna, IL 61074-9639			
8a. NAME OF FUNDING/SPONSORING ORGANIZATION U.S. Army Armament, Munitions and Chemical Command		8b. OFFICE SYMBOL (if applicable) SMCAR-ESK	9. PROCUREMENT INSTRUMENT IDENTIFICATION NUMBER		
8c. ADDRESS (City, State, and ZIP Code) Rock Island, IL 61299-7300		10. SOURCE OF FUNDING NUMBERS			
		PROGRAM ELEMENT NO.	PROJECT NO.	TASK NO.	WORK UNIT ACCESSION NO.
11. TITLE (Include Security Classification) MIL-STD-1660 Test of Unitization Procedure for Armor Tile, M1 and M2, Packed in Wooden Boxes					
12. PERSONAL AUTHOR(S) A. C. McIntosh, Jr.					
13a. TYPE OF REPORT FINAL		13b. TIME COVERED FROM _____ TO _____		14. DATE OF REPORT (Year, Month, Day) 1988 February	15. PAGE COUNT 29
16. SUPPLEMENTARY NOTATION					
17. COSATI CODES			18. SUBJECT TERMS (Continue on reverse if necessary and identify by block number)		
FIELD	GROUP	SUB-GROUP	MIL-STD-1660		
			Ammo Tile Ammunition		
			Unitization Test		
19. ABSTRACT (Continue on reverse if necessary and identify by block number)					
<p>The U.S. Army Defense Ammunition Center and School (USADACS), Evaluation Division (SMCAC-DEV), has been tasked by the Storage and Outloading Division (SMCAC-DEO) to test the armor tile palletization depicted in amended unitization procedures for armor tile, M1 and M2 packed two (M2) or three (M1) per wooden box, unitized 32 boxes per 35' X 45-1/2' pallet; approximate box size is 38' long X 13-1/4' wide X 4-9/16' high. The testing procedure used for this unitization is MIL-STD-1660 Design Criteria for Ammunition Unit Loads. The subject tests performed on this procedure were compression test, transportation simulation, edgewise rotational drop, inclined impact, and mechanical handling tests. The unitization satisfactorily met the requirements of MIL-STD-1660.</p>					
20. DISTRIBUTION/AVAILABILITY OF ABSTRACT <input checked="" type="checkbox"/> UNCLASSIFIED/UNLIMITED <input type="checkbox"/> SAME AS RPT. <input type="checkbox"/> DTIC USERS			21. ABSTRACT SECURITY CLASSIFICATION UNCLASSIFIED		
22a. NAME OF RESPONSIBLE INDIVIDUAL THOMAS J. MICHELS, Chief, Evaluation Division		22b. TELEPHONE (Include Area Code) AV 585-8928 (815)		22c. OFFICE SYMBOL SMCAC-DEV	

DD Form 1473, JUN 86

Previous editions are obsolete.

SECURITY CLASSIFICATION OF THIS PAGE
UNCLASSIFIED

U.S. ARMY DEFENSE AMMUNITION CENTER AND SCHOOL
 Evaluation Division
 Savanna, IL 61074-9639

EVT 48-87

MIL-STD-1660 TEST OF UNITIZATION PROCEDURE
 FOR ARMOR TILE, M1 AND M2, PACKED IN WOODEN BOXES

TABLE OF CONTENTS

PART		PAGE NO.
1.	INTRODUCTION	1-1
	A. Background	1-1
	B. Authority.	1-1
	C. Objective.	1-1
2.	ATTENDEES.	2-1
3.	TEST PROCEDURES.	3-1
4.	TEST EQUIPMENT	4-1
5.	TEST RESULTS	5-1
6.	CONCLUSIONS AND RECOMMENDATIONS	6-1
7.	PHOTOGRAPHS.	7-1
8.	UNITIZATION PROCEDURE	8-1

Accession For	
NTIS GRA&I	<input checked="" type="checkbox"/>
DTIC TAB	<input type="checkbox"/>
Unannounced	<input type="checkbox"/>
Justification	
By _____	
Distribution/	
Availability Codes	
Dist	Avail and/or Special
A-1	



PART 1

INTRODUCTION

A. BACKGROUND. The U.S. Army Defense Ammunition Center and School (USADACS), Evaluation Division (SMCAC-DEV) was tasked by the Storage and Outloading Division (SMCAC-DEO) to test a unitization procedure for Armor Tile packed in wooden boxes of approximately 38' long by 13-1/2' wide by 4-9/16' high in accordance with MIL-STD-1660.

B. AUTHORITY. This test was conducted in accordance with mission responsibilities delegated by the U.S. Army Armament, Munitions and Chemical Command (AMCCOM).

C. OBJECTIVE. The objective the tests identified in MIL-STD-1660 is to determine if subject unitization procedure for Armor Tile, as unitized, will satisfactorily meet the test requirements to assure safe handling and transport throughout the Army logistics system.

PART 2

ATTENDEES

Mr. A. C. McIntosh, Jr.
Test Engineer
AV 585-8989

U.S. Army Defense Ammunition Center and School
ATTN: SMCAC-DEV
Savanna, IL 61074-9639

Mr. David V. Valant
Electronics Technician
AV 585-8988

U.S. Army Defense Ammunition Center and School
ATTN: SMCAC-DEV
Savanna, IL 61074-9639

Ms. Laura Fieffer
Design Engineer
AV 585-8927

U.S. Army Defense Ammunition Center and School
ATTN: SMCAC-DEO
Savanna, IL 61074-9639

PART 3

TEST PROCEDURES

The test procedures outlined in this section are extracted from MIL-STD-1660, Design Criteria for Ammunition Unit Loads, 8 April 1977.

This standard identifies nine steps that a unitized load must undergo if it is considered to be acceptable. These tests are synopsized below:

1. STACKING TESTS. The unit load shall be loaded to simulate a stack of identical unit loads stacked 16 feet high, for a period of one hour. This stacking load is simulated by subjecting the unit load to a compression of weight equal to an equivalent 16-foot stacking height. The compression load is calculated in the following manner. The unit load weight is divided by the unit load height in inches and multiplied by 192. The resulting number is the equivalent compressive force of a 16-foot-high load.
2. REPETITIVE SHOCK TEST. The repetitive shock test shall be conducted in accordance with Method 5019, Federal Standard 101. The test procedure is as follows. The test specimen shall be placed on, but not fastened to, the platform. With the specimen in one position, vibrate the platform at 1/2-inch amplitude (1-inch double amplitude) starting at a frequency of about 3 cycles per second. Steadily increase the frequency until the package leaves the platform. The resonant frequency is achieved when a 1/16-inch-thick feeler may be momentarily slid freely between every point on the specimen in contact with the platform at some instance during the cycle or a platform acceleration achieves one plus or minus zero point one G. Midway into the testing period the specimen shall be rotated 90 degrees and the test continued for the duration. If failure occurs, the total time of vibration shall be two hours

if the specimen is tested in one position; and if tested in more than one position, the total time shall be three hours.

3. EDGEWISE DROP TEST. This test shall be conducted by using the procedures of Method 5008, Federal Standard 101. The procedure for the Edgewise Drop (Rotational) Test is as follows: The specimen shall be placed on its bottom with one end of the base of the container supported on a sill nominally 6 inches high. The height of the sill shall be increased if necessary to ensure that there will be no support for the base between the ends of the container when dropping takes place, but should not be high enough to cause the container to slide on the supports when the dropped end is raised for the drops. The unsupported end of the container shall then be raised and allowed to fall freely to the concrete, pavement, or similar underlying surface from a prescribed height. Unless otherwise specified, the height of drop for level A protection shall conform to the following tabulation.

GROSS WEIGHT NOT EXCEEDING	DIMENSIONS ON ANY EDGE NOT EXCEEDING	HEIGHT OF DROP LEVEL A PROTECTION
Pounds	Inches	Inches
600	72	36
3,000	no limit	24
no limit	no limit	12

4. MECHANICAL HANDLING WITH ATTACHMENTS. This test shall be conducted in accordance with Method 5011, Federal Standard 101 Sub-Part 6.3, Hoisting With Slings. Attach slings to the four hoisting arrangements. The length of the slings shall be such that, when lifting, they form angles between 20 and 25 degrees with a horizontal plane. Lift the specimen clear of the floor and hold it suspended for not less than two minutes. Observe for any

indications of inadequacies in this specimen. Record observations and let the specimen down. Repeat the previous procedure using three, two, alternate two, and one sling.

5. IMPACT TEST. This test shall be conducted by using the procedure of Method 5023, Incline-Impact Test of Federal Standard 101. The procedure for the Incline-Impact Test is as follows: The specimen shall be placed on the carriage with the surface or edge which is to be impacted projecting at least 2 inches beyond the front end of the carriage. The carriage shall be brought to a predetermined position on the incline and released. If it is desired to concentrate the impact on any particular position on the container, a 4x4 inch timber may be attached to the bumper in the desired position before the test. No part of the timber shall be struck by the carriage. The position of the container on the carriage and the sequence in which surfaces and edges are subjected to impacts may be at the option of the testing activity and will depend upon the objective of the tests. When the test is to determine satisfactory requirements for a container or pack and unless otherwise specified the specimen shall be subjected to one impact on each surface that has each dimension less than 9.5 feet. Unless otherwise specified, the velocity at time of impact shall be 7 feet per second.

PART 4

TEST EQUIPMENT

1. TEST SPECIMEN.
 - a. Drawing Number: 19-48-4221-20PA1009
 - b. Width: 38'
 - c. Length: 54'
 - d. Height: 44'
 - e. Weight: 2,508 lbs.
2. COMPRESSION TESTER.
 - a. Manufacturer: Ormond Scientific
 - b. Platform: 60 inches by 60 inches
 - c. Compression Limit: 50,000 pounds
 - d. Tension Limit: 50,000 pounds
3. TRANSPORTATION SIMULATOR.
 - a. Manufacturer: Gaines Laboratory
 - b. Capacity: 6,000 pound pallet
 - c. 1/2-inch Amplitude
 - d. Speed: 50 to 3000 cpm
 - e. Platform: 5 foot by 8 foot
4. INCLINED RAMP.
 - a. Manufacturer: Conbur Incline
 - b. Impact Tester
 - c. 10% Incline
 - d. 12-foot Incline
5. Forklift Rough Handling Course.

PART 5

TEST RESULTS

1. STACKING TEST.

Pallet Weight: 2,508 lbs.

Pallet Height: 44"

Test Load Weight: 10,900 lbs.

The subject pallet was loaded to 11,000 lbs. compression for a period of one hour. At the end of this period of time, the compressive load had decreased to 9,800 lbs. While in the compression tester, the unitization decreased 1/2" in overall height. When removed from the compression tester, irregular packing boxes allowed the load to resume its initial height of 44".

2. REPETITIVE SHOCK TEST. Subject pallet successfully passed the longitudinal transportation simulation test during a 90-minute test period. Rotating the pallet 90 degrees and subjecting it to a second 90-minute period in the transportation simulator caused no damage to the pallet or loosening of the strapping. In order to achieve a 1/16" clearance between the pallet and the transportation simulator bed, the equipment was operated at 180 rpm.

3. EDGEWISE DROP TEST. Each side of the pallet base was placed, in turn, on a beam displacing it 6" above the floor. The opposite side was raised to a height of 24" above the floor and then dropped. This process was repeated until the pallet had been dropped on all four sides. No damage occurred to the pallet during the edgewise rotational drop test.

4. MECHANICAL HANDLING TEST. The mechanical handling test was accomplished using a forklift. This occurred while moving the pallet between test stations and storage buildings over gravel roads. All forks were engaged in the fork pockets provided on the pallet. No damage or deflection of the specimen occurred that could cause damage to or displacement of the contents.

5. IMPACT TEST. The inclined impact test consisted of placing the test pallet on an inclined sled with 2' of the pallet projecting over the edge of the sled on the impact side. The sled was then raised approximately 8 ft. up the inclined ramp and allowed to accelerate and impact into a solid wall. This test was repeated once on each side of the pallet. This inclined impact did not use an optional bumper. No damage occurred to the unit load after impacting all four sides.

PART 6

CONCLUSIONS AND RECOMMENDATIONS

1. CONCLUSIONS. The unitization procedures for armor tile, M1 and M2, as depicted in the unitization procedure drawing 19-48-4221-20PA1009, as amended, satisfy the requirements of MIL-STD-1660 as tested in this report.
2. RECOMMENDATIONS. It is recommended that subject unitization procedures be implemented to the extent allowed for the handling, storage, and transport of armor tile identified.

PART 7
PHOTOGRAPHS

DEFENSE AMMUNITION CENTER AND SCHOOL - SAVANNA, IL

Photo No. 1. This photo shows the armor tile pallet in the compression tester.



DEFENSE AMMUNITION CENTER AND SCHOOL - SAVANNA, IL

Photo No. 2. This photo shows the armor tile pallet after being taken out of the compression tester. Note the indentations in the pallet strapping. This was caused by improper stacking of the pallet on top of the unitization. The compressive load has permanently deformed the 3/4" strapping, causing the tiedown straps to loosen.



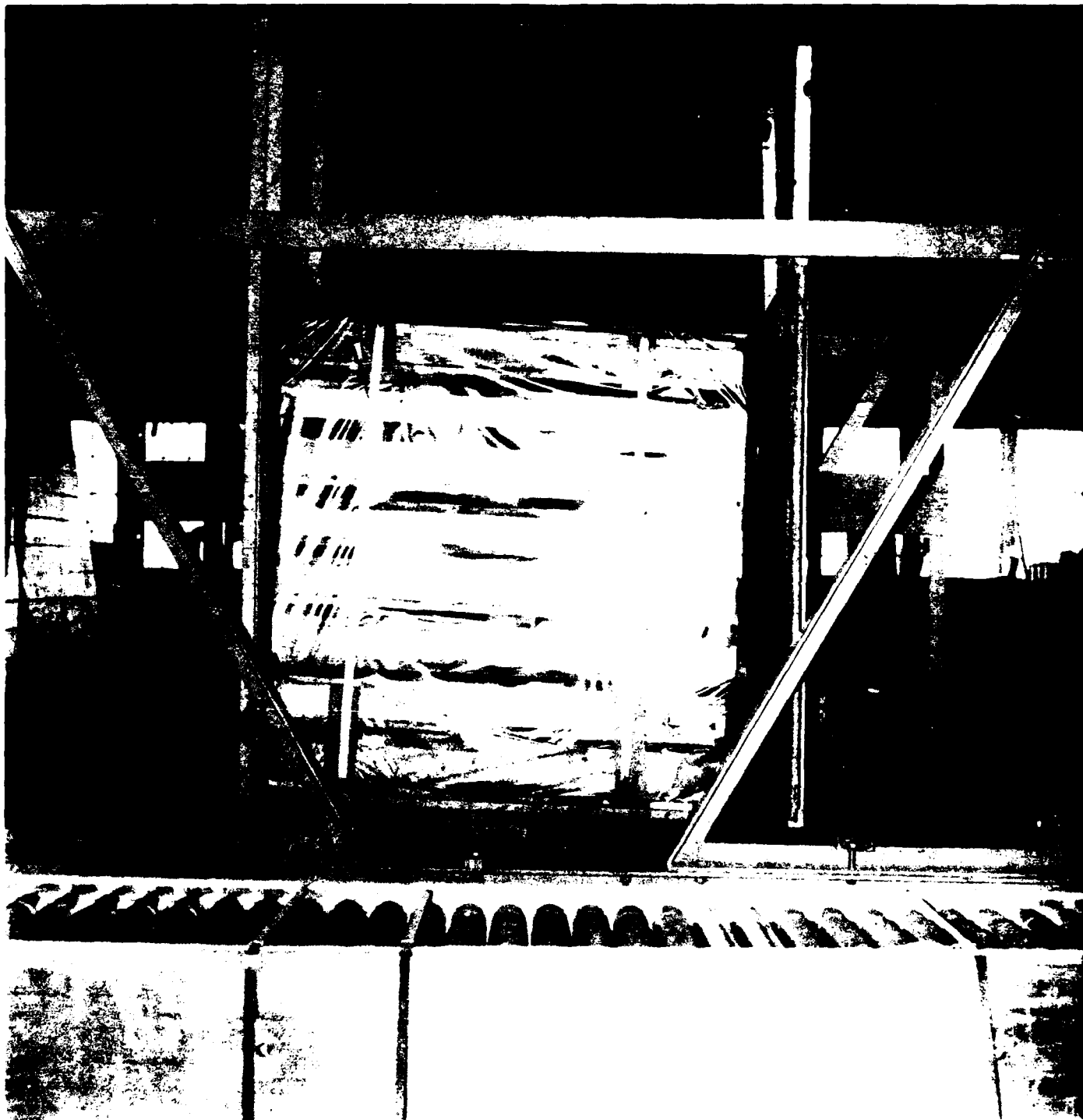

DEFENSE AMMUNITION CENTER AND SCHOOL - SAVANNA, IL

Photo No. 3. This photo shows the armor tile unit load on the transportation simulator. Plastic cover only used in this test to reduce dust from inert filler.

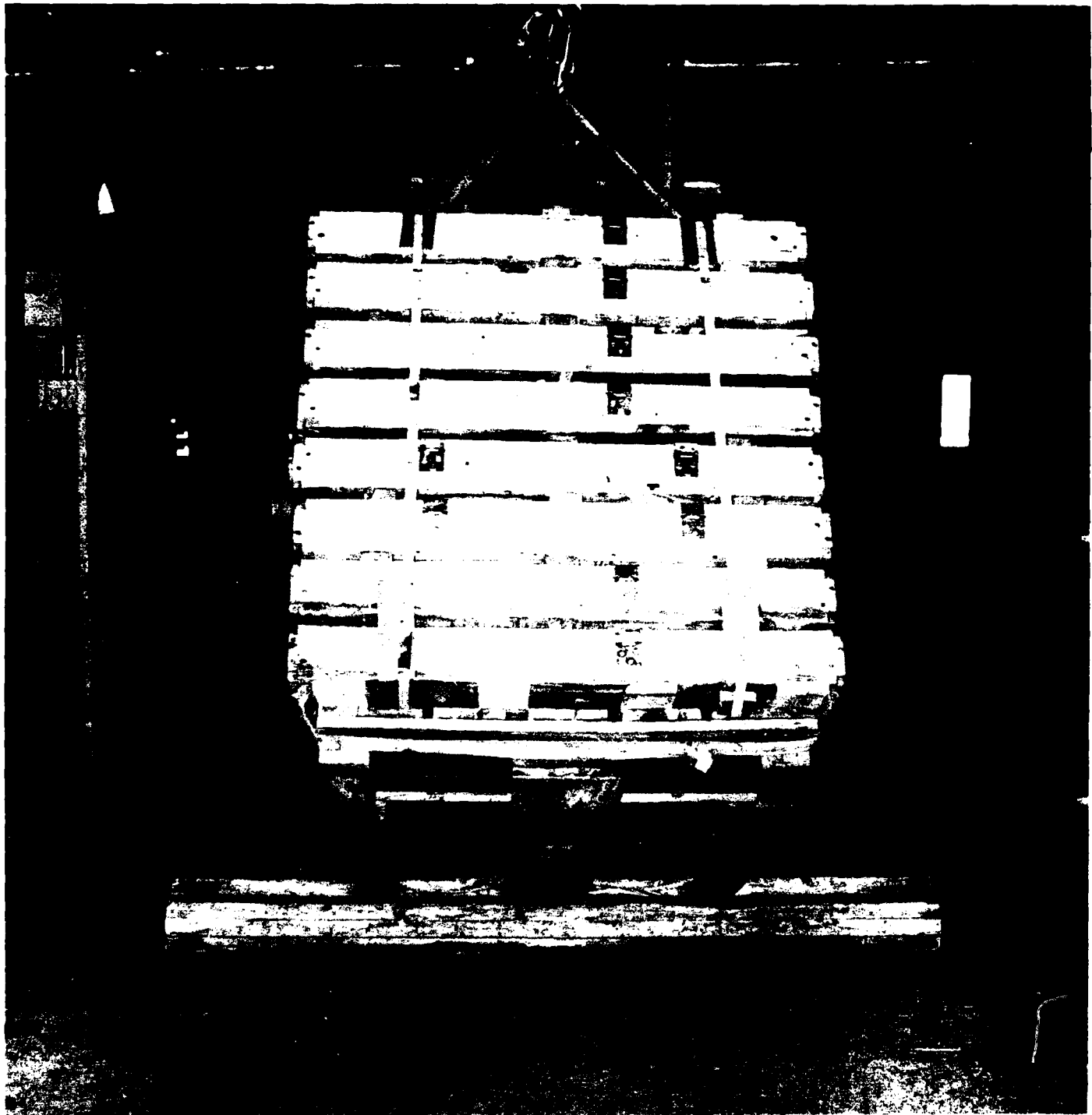

DEFENSE AMMUNITION CENTER AND SCHOOL - SAVANNA, IL

Photo No. 4. This photo shows the armor tile unit load ready for the first edgewise rotational drop.

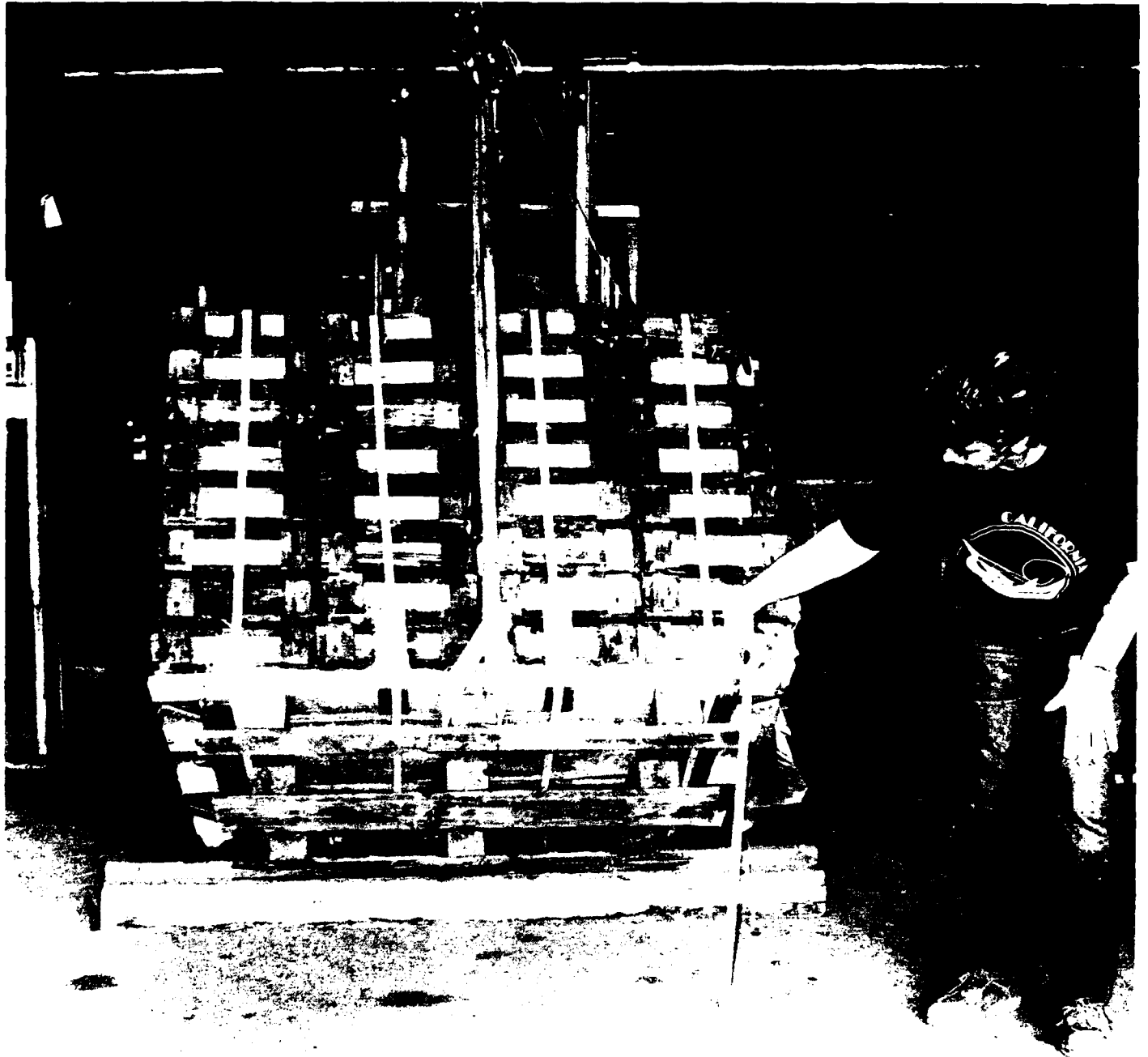

DEFENSE AMMUNITION CENTER AND SCHOOL - SAVANNA, IL

Photo No. 5. This photo shows the armor tile unit load ready for the second edgewise rotational drop.

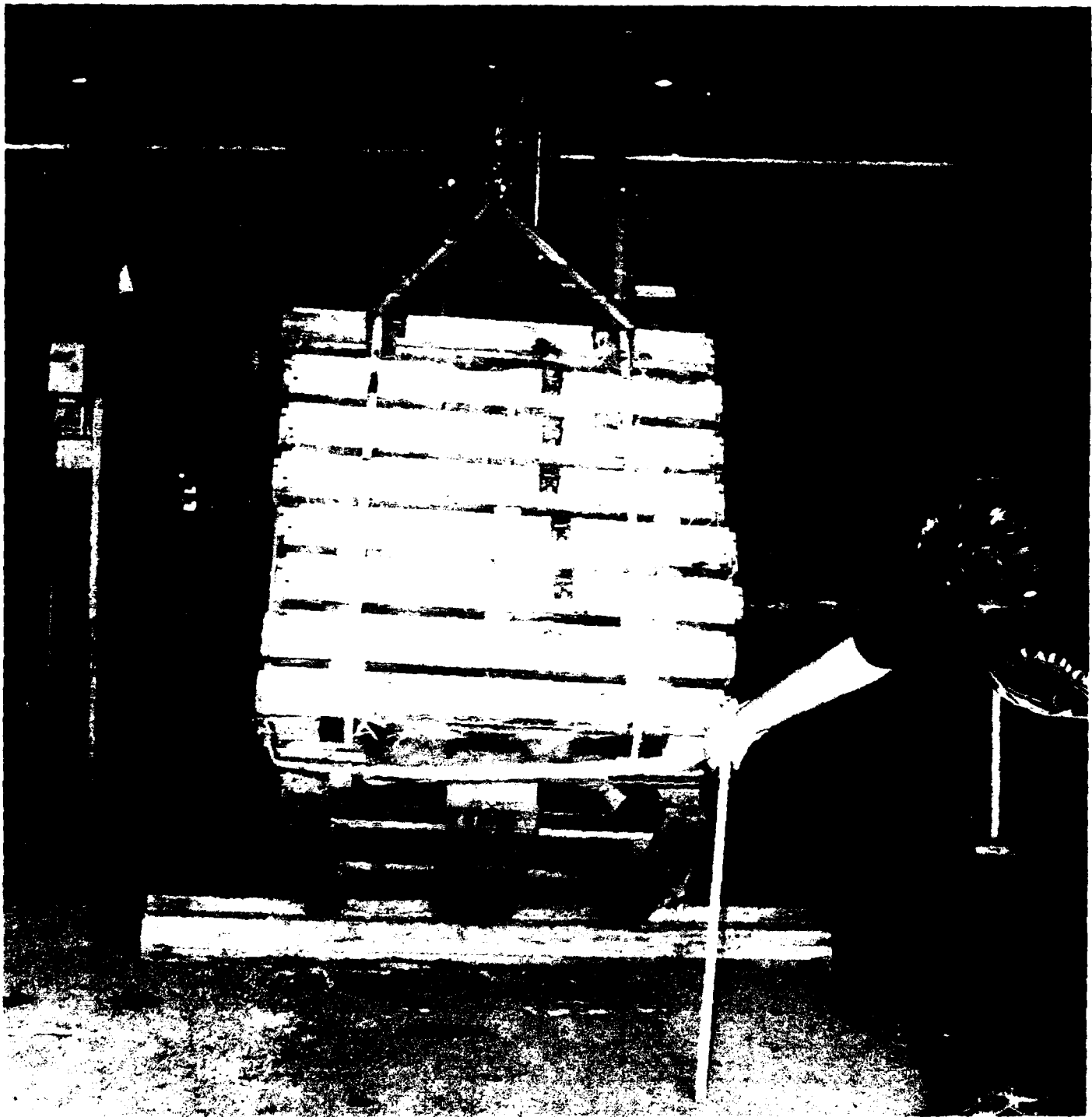

DEFENSE AMMUNITION CENTER AND SCHOOL - SAVANNA, IL

Photo No. 6. This photo shows the armor tile unit load ready for the third edgewise rotational drop.



DEFENSE AMMUNITION CENTER AND SCHOOL - SAVANNA, IL

Photo No. 7. This photo shows the armor tile unit load ready for the fourth edgewise rotation drop. Note the center skid on the left has cracked from the previous edgewise rotational drop.

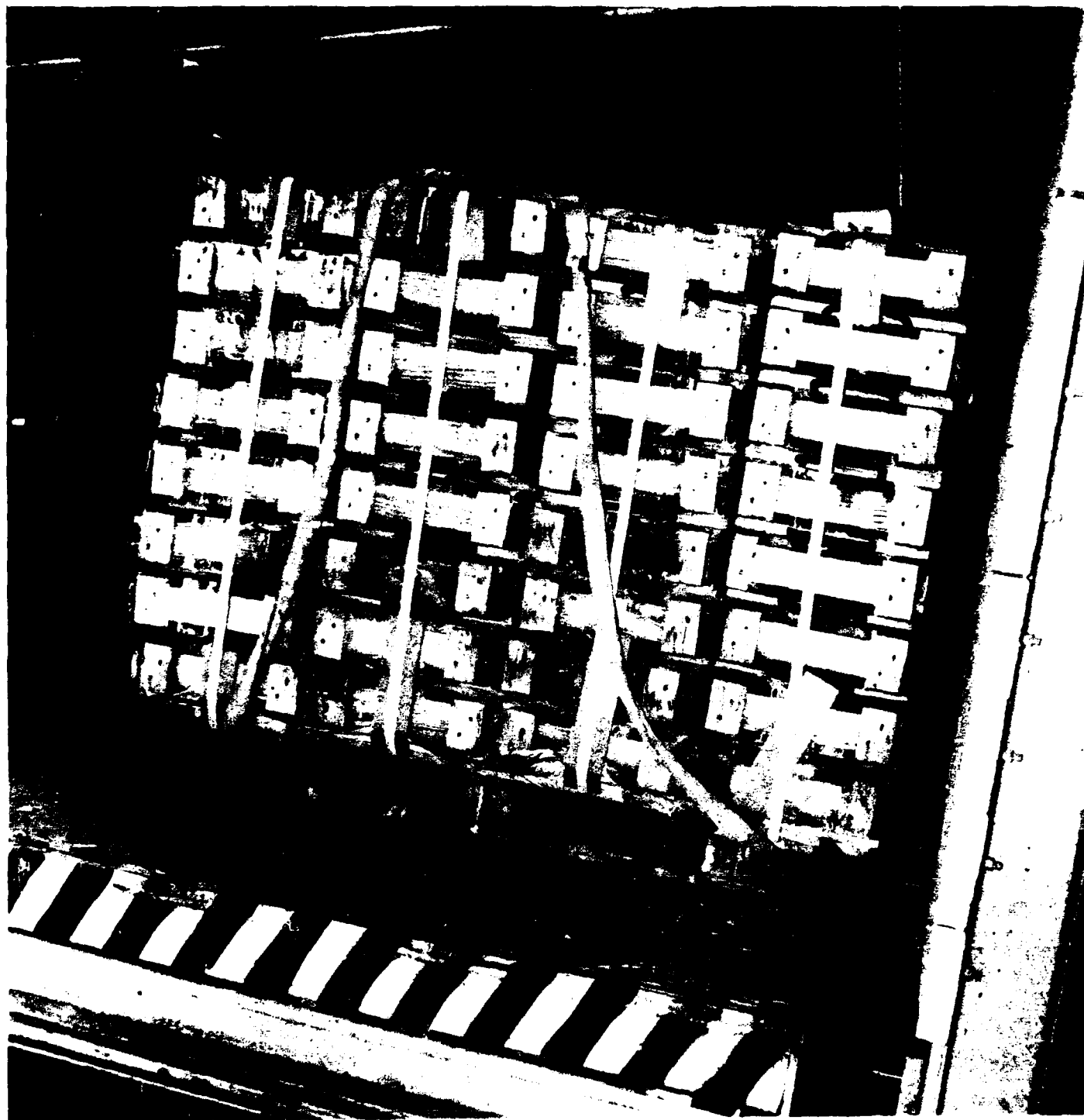

DEFENSE AMMUNITION CENTER AND SCHOOL - SAVANNA, IL

Photo No. 8. This photo shows the armor tile unit load after the first inclined impact.



DEFENSE AMMUNITION CENTER AND SCHOOL- SAVANNA, IL

Photo No. 9. This photo shows the armor tile unit load after the second inclined impact.



DEFENSE AMMUNITION CENTER AND SCHOOL - SAVANNA, IL

Photo No. 10. This photo shows the armor tile unit load after the third inclined impact. Note the slight loosening of the armor tile boxes in the first row.



DEFENSE AMMUNITION CENTER AND SCHOOL - SAVANNA, IL

Photo No. 11. This photo shows the armor tile unit load after impact on the fourth and last side.

PART 8.
UNITIZATION PROCEDURES

UNITIZATION PROCEDURES FOR ARMOR TILE, XMI AND XM2, PACKED 2 (XM2) OR 3 (XMI) PER WOODEN BOX, UNITIZED 32 BOXES PER 35" X 45-1/2" PALLET; APPROX BOX SIZE 38" L X 13-1/4" W X 4-9/16" H

PALLET UNIT DATA						
ITEMS INCLUDED		HAZARD CLASSIFICATION ^①				WEIGHT
NSN	DODIC	DOT CLASS	CG CLASS	QD CLASS	COMP GROUP	(LBS)
1375- 01-223-1413	ML91	A	IV	(04) 1.2	D	2,472
01-223-2918	ML92	A	IV	(04) 1.2	D	2,472

① HAZARD CLASSIFICATION DATA CONTAINED IN THE CHART TO THE LEFT IS FOR GUIDANCE AND INFORMATIONAL PURPOSES ONLY. VERIFICATION OF THE SPECIFIED DATA SHOULD BE MADE BY CONSULTING THE MOST RECENT JOINT HAZARD CLASSIFICATION SYSTEM LISTING OR OTHER APPROVED LISTING (S).

REVISION

REVISION NO. 1, DATED JUNE 1986, CONSISTS OF:
 ADDING ITEM BY NATIONAL STOCK NUMBER (NSN)
 TO "PALLET UNIT DATA" CHART.

REVISIONS				Date/Initial	Date/Initial	Date/Initial
1	JUN 86	N/A	N/A	LAF/WRF	LAF/WRF	LAF/WRF
				<small>APPROVED BY U.S. ARMY AMC, QUANTICO AND QUANTICO, VA</small> <small>APPROVED BY U.S. ARMY AMC, QUANTICO AND QUANTICO, VA</small> <small>U.S. ARMY AMC DRAWING</small> <small>MARCH 1986</small>		
CLASS	DIVISION	DRAWING	FILE			
19	48	4221	20PA 1009			

DO NOT SCALE

TIEDOWN STRAP, 3/4" X .035" OR .031" X 13'-6" LONG STEEL STRAPPING (4 REQD). SEE GENERAL NOTE "D" AT RIGHT.

LOAD STRAP, 3/4" X .035" OR .031" X 16'-0" LONG STEEL STRAPPING (2 REQD). SEE GENERAL NOTE "C" AT RIGHT.

SEAL FOR 3/4" STRAPPING (6 REQD, 1 PER STRAP). CRIMP EACH SEAL WITH TWO PAIR OF NOTCHES.

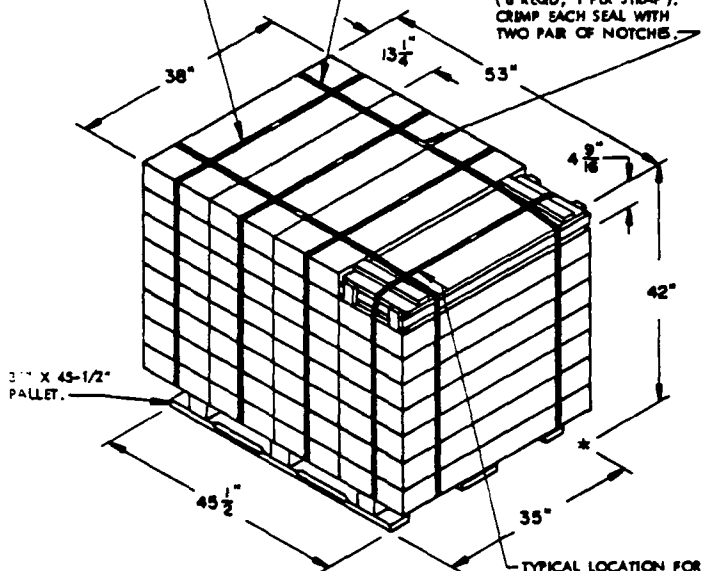

PALLET UNIT

SEE GENERAL NOTE "B" AT RIGHT.

32 BOXES OF ARMOR TILES (2 OR 3 PER BOX) ± 75 LBS	2,400 LBS (APPROX)
DUNNAGE	7 LBS
PALLET	65 LBS
TOTAL WEIGHT	2,472 LBS (APPROX)
CUBE	49.0 CU FT (APPROX)

BILL OF MATERIAL

PALLET, 35" X 45-1/2"	1 REQD	65 LBS
STEEL STRAPPING, 3/4"	86.00' REQD	6.14 LBS
SEAL FOR 3/4" STRAPPING	6 REQD	NIL

TIE PIECE, 1" X 4" X BOX WIDTH (2 REQD). NAIL TO LONGITUDINAL PIECES W/2-6d NAILS AT EACH END AND TO LATERAL PIECE W/2-6d NAILS.

VERTICAL PIECE, 2" X 4" X BOX HEIGHT MINUS 3/4" (4 REQD).

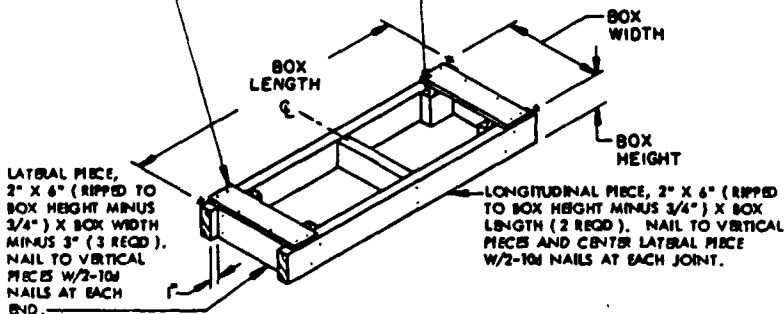

FILLER ASSEMBLY
(FOR MINUS ONE BOX)

GENERAL NOTES

- A. THIS DOCUMENT HAS BEEN PREPARED AND ISSUED IN ACCORDANCE WITH AR 740-1 AND AUGMENTS TM 743-200-1 (CHAPTER 5) AND CONFORMS TO MIL-STD-1660.
- B. DIMENSIONS, CUBE AND WEIGHT OF A PALLET UNIT WILL VARY SLIGHTLY DEPENDING UPON THE ACTUAL DIMENSIONS OF THE BOXES AND THE WEIGHT OF THE SPECIFIC ITEM BEING UNITIZED.
- C. THE LOAD STRAPS MAY BE THREADED THROUGH THE STRAP SLOTS OF A PALLET OR PRE-POSITIONED ON THE PALLET DECK PRIOR TO PLACING BOXES ON THE PALLET. LOAD STRAPS MUST BE TENSIONED AND SEALED PRIOR TO APPLICATION OF TIEDOWN STRAPS.
- D. INSTALL EACH TIEDOWN STRAP TO PASS UNDER THE DECK/STRINGER BOARDS OF THE PALLET AND TO BE LOCATED AS SHOWN. TIEDOWN STRAPS WILL NOT BE APPLIED UNTIL THE LOAD STRAPS HAVE BEEN TENSIONED AND SEALED.
- E. THE FOLLOWING AMC (DARCOM) DRAWINGS ARE APPLICABLE FOR OUTLOADING AND STORAGE OF THE ITEMS COVERED BY THIS APPENDIX.
MILVAN — DRAWING 19-48-166-15PA1002.
CARLOADING — DRAWING 19-48-4115-3PA1002.
TRUCKLOADING — DRAWING 19-48-4117-11PA1002.
STORAGE — DRAWING 19-48-4118-1-2-3-4-14-22PA1002.
- F. FOR METHOD OF SECURING A STRAP CUTTER TO THE PALLET UNIT, SEE DARCOM DRAWING 19-48-4127-20P1000.
- G. IF ITEMS COVERED HEREIN ARE UNITIZED PRIOR TO ISSUANCE OF THIS DRAWING, THE BOXES NEED NOT BE REUNITIZED SOLELY TO CONFORM TO THIS APPENDIX.
- H. WHEN APPLYING ANY STRAP, CARE MUST BE EXERCISED TO ASSURE THAT THE END OF THE STRAP ON THE UNDERSIDE OF THE JOINT EXTENDS AT LEAST 6" BEYOND THE SEAL. THIS EXTRA MINIMUM LENGTH OF STRAP IS REQUIRED TO PERMIT SUBSEQUENT TIGHTENING OF LOOSENED STRAPPING. RETENSIONING CAN BE ACCOMPLISHED WITHOUT REPLACING STRAPPING OR SPLICING STRAPPING THROUGH THE USE OF A FEEDWHEEL TENSIONING TOOL, MANUAL OR PNEUMATIC, AND THE APPLICATION OF ONE ADDITIONAL SEAL.
- J. ALL WOODEN DUNNAGE AND PALLETS MUST BE PRESERVATIVE TREATED WITH EITHER COPPER-8-QUINOLINOLATE OR ZINC NAPHTHENATE EMULSIFIABLE. PALLETS AND DUNNAGE ASSEMBLIES MUST BE ASSEMBLED PRIOR TO TREATMENT. THE LETTERS "PA" DENOTING PG56 (COPPER-8-QUINOLINOLATE) OR "PB" DENOTING M-GARD W530 (ZINC NAPHTHENATE EMULSIFIABLE) MUST BE APPLIED TO THE OUTER FACE OF THE CENTER POST ON THE 45-1/2" SIDES OF THE PALLET, IN LETTERS AT LEAST ONE-INCH HIGH.
- K. A PLUS OR MINUS 1/4" IS ALLOWED ON OVERALL DIMENSIONS OF ANY DUNNAGE ASSEMBLY. HOWEVER, SIMILAR PIECES IN AN ASSEMBLY MUST BE WITHIN 1/8" OF THE SAME DIMENSION.
- L. IN ORDER TO OBTAIN COMPACT (SOUND) UNITS, ALL STRAPS SHALL BE LOCATED IN PROPER ALIGNMENT AND TENSIONED UNTIL THEY CUT INTO THE EDGE OF THE PALLET DECK. AFTER TENSIONING, ALL STRAPS WILL BE SECURED USING ONE SEAL AND TWO PAIR OF NOTCHES.
- M. DIMENSIONAL LUMBER SPECIFIED THROUGHOUT THIS PROCEDURAL DRAWING IS OF NOMINAL SIZE UNLESS OTHERWISE SPECIFIED. FOR EXAMPLE, 1" X 4" MATERIAL IS ACTUALLY 3/4" THICK BY 3-1/2" WIDE AND 2" X 4" MATERIAL IS ACTUALLY 1-1/2" THICK BY 3-1/2" WIDE.

MATERIAL SPECIFICATIONS

PALLET	MIL SPEC MIL-P-15011; 4-WAY ENTRY, STYLE IA, TYPE I, CLASS 1, PRESERVATIVE TREATED. SEE GENERAL NOTE "J".
LUMBER	SEE TM 743-200-1 (DUNNAGE LUMBER) AND FED SPEC MM-L-757.
NAILS	FED SPEC FF-N-105; COMMON. ALT: ANNULAR-RING TYPE NAIL OR PALLET TYPE (MECHANICALLY DEFORMED) NAIL OF SAME SIZE.
STRAPPING, STEEL	FED SPEC QQ-5-781; CLASS 1, TYPE I OR II, HEAVY DUTY, FINISH B (GRADE 2), SIZE 3/4" X .035" OR .031".
SEAL, STRAP	FED SPEC QQ-5-781; TYPE D, STYLE I, II, OR III, CLASS H, FINISH B (GRADE 2).