

AD-A207 556

EVALUATION OF AN OPTICAL CORRELATOR AND MATCHED FILTER
MAKER. (U) ARMY MISSILE COMMAND REDSTONE ARSENAL AL
RESEARCH DIRECTORATE. J L STENSBY ET AL. 20 FEB 89

1/1

UNCLASSIFIED

AMSNI/TR-RD-RE-89-4 S81-AD-E951 331

F/G 9/5

ML

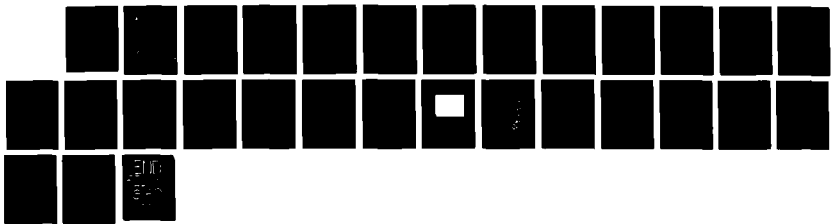

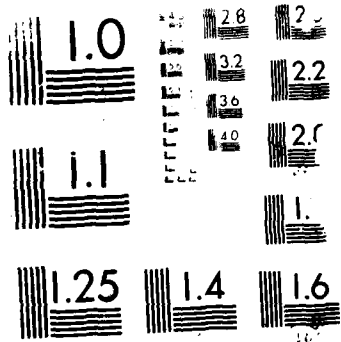

2

AD-A207 556



TECHNICAL REPORT RD-RE-89-4

EVALUATION OF AN OPTICAL CORRELATOR AND MATCHED FILTER MAKER

John L. Stensby
Charles R. Christensen
Research Directorate
Research, Development, and
Engineering Center

FEBRUARY 1989

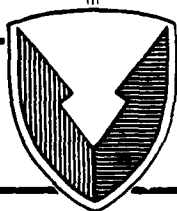

U.S. ARMY MISSILE COMMAND

Redstone Arsenal, Alabama 35898-5000

Cleared for public release; distribution is unlimited.

DTIC
ELECTE
APR 21 1989
S H D

89 4 21 028

DISPOSITION INSTRUCTIONS

**DESTROY THIS REPORT WHEN IT IS NO LONGER NEEDED. DO NOT
RETURN IT TO THE ORIGINATOR.**

DISCLAIMER

**THE FINDINGS IN THIS REPORT ARE NOT TO BE CONSTRUED AS AN
OFFICIAL DEPARTMENT OF THE ARMY POSITION UNLESS SO DESIG-
NATED BY OTHER AUTHORIZED DOCUMENTS.**

TRADE NAMES

**USE OF TRADE NAMES OR MANUFACTURERS IN THIS REPORT DOES
NOT CONSTITUTE AN OFFICIAL INDORSEMENT OR APPROVAL OF
THE USE OF SUCH COMMERCIAL HARDWARE OR SOFTWARE.**

UNCLASSIFIED

SECURITY CLASSIFICATION OF THIS PAGE

REPORT DOCUMENTATION PAGE				Form Approved OMB No 0704-0188 Exp Date Jun 30, 1986	
1a. REPORT SECURITY CLASSIFICATION UNCLASSIFIED		1b. RESTRICTIVE MARKINGS			
2a. SECURITY CLASSIFICATION AUTHORITY		3. DISTRIBUTION/AVAILABILITY OF REPORT Cleared for public release; distribution is unlimited.			
2b. DECLASSIFICATION/DOWNGRADING SCHEDULE					
4. PERFORMING ORGANIZATION REPORT NUMBER(S) TR-RD-RE-89-4		5. MONITORING ORGANIZATION REPORT NUMBER(S)			
6a. NAME OF PERFORMING ORGANIZATION Research Directorate RD&E Center	6b. OFFICE SYMBOL (if applicable) AMSMI-RD-RE	7a. NAME OF MONITORING ORGANIZATION			
6c. ADDRESS (City, State, and ZIP Code) Redstone Arsenal, AL 35898		7b. ADDRESS (City, State, and ZIP Code)			
8a. NAME OF FUNDING/SPONSORING ORGANIZATION	8b. OFFICE SYMBOL (if applicable)	9. PROCUREMENT INSTRUMENT IDENTIFICATION NUMBER			
8c. ADDRESS (City, State, and ZIP Code)		10. SOURCE OF FUNDING NUMBERS			
		PROGRAM ELEMENT NO.	PROJECT NO.	TASK NO.	WORK UNIT ACCESSION NO.
11. TITLE (Include Security Classification) EVALUATION OF AN OPTICAL CORRELATOR AND MATCHED FILTER MAKER					
12. PERSONAL AUTHOR(S) John L. Stensby and Charles R. Christensen					
13a. TYPE OF REPORT Final	13b. TIME COVERED FROM _____ TO _____	14. DATE OF REPORT (Year, Month, Day) 1989/February/28	15. PAGE COUNT 28		
16. SUPPLEMENTARY NOTATION					
17. COSATI CODES		18. SUBJECT TERMS (Continue on reverse if necessary and identify by block number)			
FIELD	GROUP	SUB-GROUP	Correlator, optical, coherent, diode laser, matched filter, array, multiple, compact		
19. ABSTRACT (Continue on reverse if necessary and identify by block number)					
<p>Experimental work with a compact, coherent, real-time optical correlator and a matched filter maker system is described. The system was designed and built by the technical staff of The Environmental Research Institute of Michigan. Attributes of the correlator included small size, the ability to correlate an input image with multiple references, and operation over a wide range of input light levels. The input scene enters the correlator by a system of lenses while the matched filters are prerecorded on a photographic plate that is inserted into the correlator. The correlator contains a miniature CCD television camera upon which the correlations are projected. The output of the camera is a standard composite video signal which can be displayed on a simple monitor. A match between the input scene and one of the stored filters is indicated by the appearance of a bright correlation spot on the output monitor.</p>					
20. DISTRIBUTION/AVAILABILITY OF ABSTRACT <input type="checkbox"/> UNCLASSIFIED/UNLIMITED <input checked="" type="checkbox"/> SAME AS RPT. <input type="checkbox"/> DTIC USERS		21. ABSTRACT SECURITY CLASSIFICATION UNCLASSIFIED			
22a. NAME OF RESPONSIBLE INDIVIDUAL Charles R. Christensen		22b. TELEPHONE (Include Area Code) 205-876-3820	22c. OFFICE SYMBOL AMSMI-RD-RE		

DD FORM 1473, 84 MAR

83 APR edition may be used until exhausted
All other editions are obsoleteSECURITY CLASSIFICATION OF THIS PAGE
UNCLASSIFIED

i/(ii Blank)

CONTENTS

	<u>Page</u>
I. INTRODUCTION.....	1
II. MATCHED FILTER MAKER.....	2
III. A COMPACT CORRELATOR.....	7
IV. EXPERIMENTAL RESULTS.....	14
V. CONCLUSIONS.....	20
REFERENCES.....	22



Accession For	
NTIS GRA&I	<input checked="" type="checkbox"/>
DTIC TAB	<input type="checkbox"/>
Unannounced	<input type="checkbox"/>
Justification	
By	
Distribution/	
Availability Codes	
	Avail and/or
Dist	Special
A-1	

I. INTRODUCTION

The cross correlation of two monochromatic images is a measure of their similarity. Let $s_1(x,y)$ and $s_2(x,y)$ denote the images; each function describes an image's magnitude and phase over the input aperture of the correlator. The cross correlation of s_1 and s_2 is defined as

$$g(x,y) = \int_{-\infty}^{\infty} \int_{-\infty}^{\infty} s_1^*(u,v) s_2(u+x,v+y) du dv. \quad (I-1)$$

In practical applications images are limited in spatial extent, and a finite domain of integration would suffice in (I-1). Generally speaking, the greater the similarity between s_1 and s_2 the greater the peak of g at $x = y = 0$. If s_2 is similar to a spatially shifted version of s_1 then g will exhibit a peak at a coordinate location indicative of the displacement between the images.

For what are mainly technological reasons, a direct implementation of (I-1) is not practical. A better approach for obtaining the cross correlation involves the Fourier transform operator \mathfrak{F} . It is easily shown that

$$g(x,y) = \mathfrak{F}^{-1} [S_1^* S_2] \quad (I-2)$$

where

$$S_1 = \mathfrak{F}[s_1] \quad (I-3)$$

$$S_2 = \mathfrak{F}[s_2].$$

The main reason (I-2) is a more practical implementation of the cross correlation operation is that the Fourier transform operation (and its inverse) and multiplication in the spatial frequency domain can be implemented optically. It is well known that if s_1 appears in the object plane of a converging lens then S_1 appears in its transform plane (the object plane lies one focal length in front of and the transform plane lies a focal length behind the lens). Also, the product $S_1 S_2^*$ can be formed by imaging S_1 on a transparency having an effective transmittance of S_2^* . Finally, a second lens can be placed after the transparency to take the inverse transform of the product.

These ideas are incorporated in a simple coherent optical correlator with schematic given by Figure 1. Input s_1 is actually a diffraction pattern which can be formed by passing collimated laser light through an input transparency of the image. The resulting far field diffraction pattern is focused by the Fourier transform lens onto the transparency containing the Fourier transform hologram made from image s_2 . What is effectively the product of the transforms appears at an angle off normal incidence to the hologram: the actual angle is determined during manufacture of the hologram. Finally, a second lens transforms the product back to form the correlation of s_1 and s_2 .

The simple ideas outlined above are developed below. Section II describes an apparatus used to manufacture the above-mentioned Fourier transform hologram. This device is referred to as the matched filter maker in what follows. Section III describes an optical correlator of unique design which is capable of performing multiple correlations simultaneously.

II. MATCHED FILTER MAKER

Figure 2 depicts a schematic of the matched filter maker. All components shown are mounted on (bolted to) an optical table. As described below, the major features of the filter maker include 1) an input image supplied by a standard television camera, 2) computer controlled self alignment, 3) computer controlled exposure sequencing, and 4) the ability to monitor the image passing through the system on an auxiliary television monitor.

The input image to the filter maker is captured on a standard television camera. The resulting signal is displayed on an enclosed TV projector complete with lens for writing the image on the input side of the liquid crystal light valve (LCLV). This arrangement provides greater flexibility and convenience than that provided by a system where the input image is focused directly on the LCLV. A diode laser within the system is used to read the image from the output side of the LCLV.

This laser diode has a nominal wavelength of 780 nanometers (nm) and

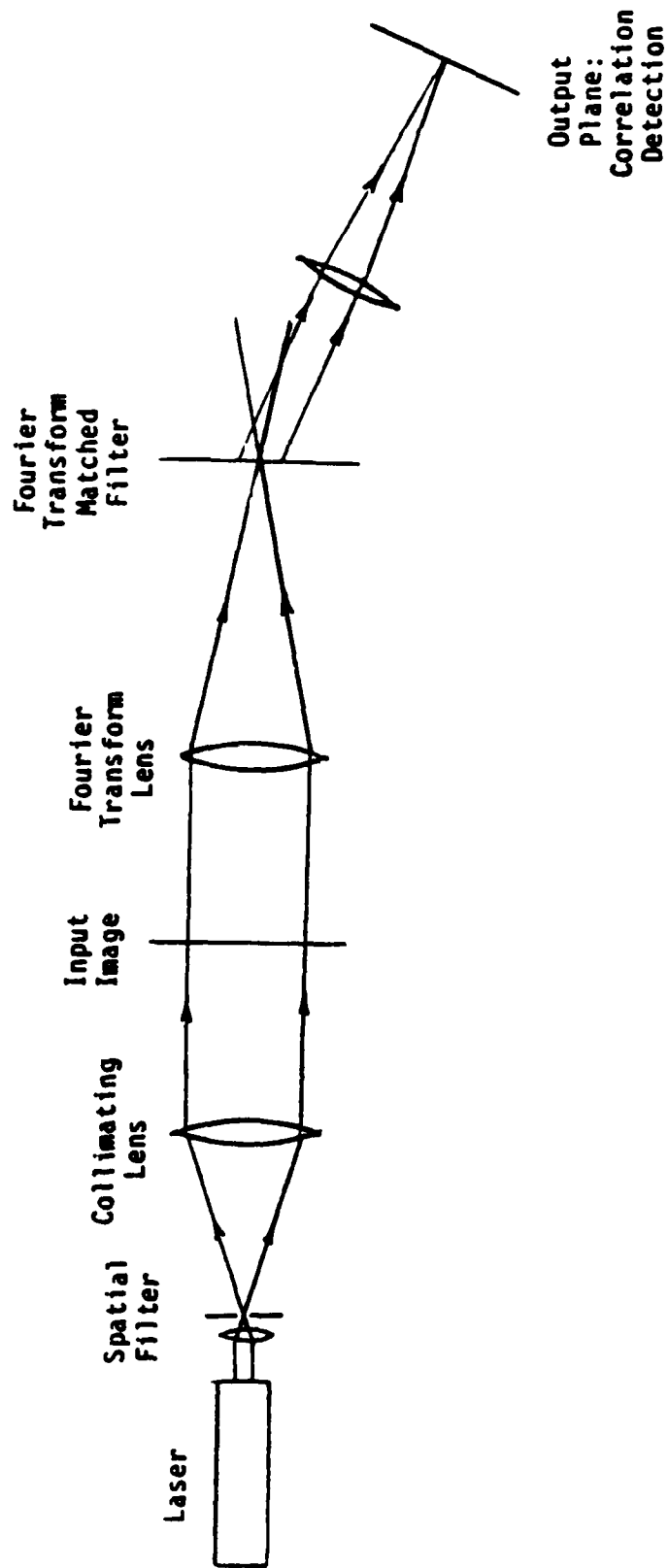

Figure 1. A simple coherent optical correlator.

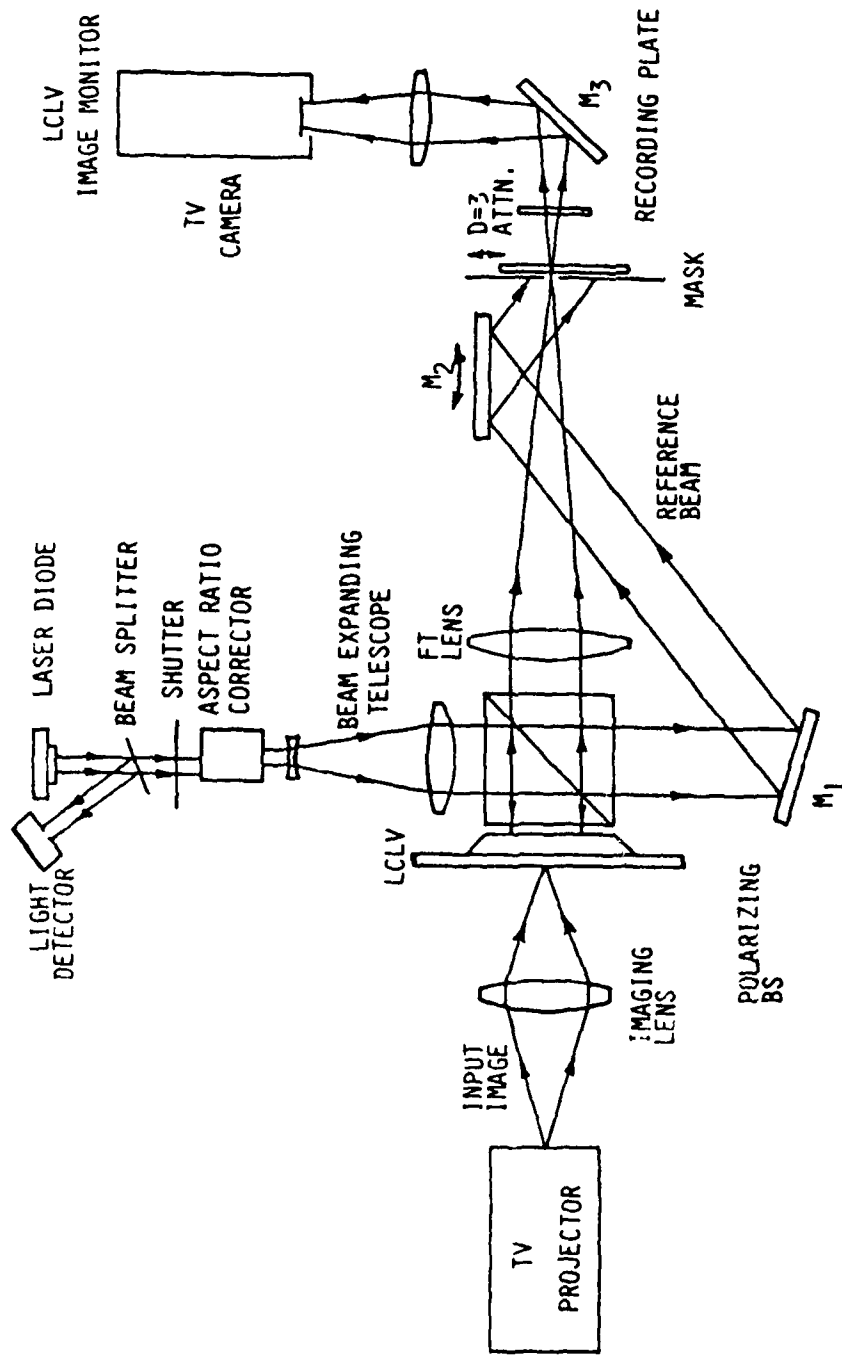

Figure 2. Schematic of matched filter maker.

50 milliwatts (mw) maximum output. The temperature of the diode is controlled by a thermo-electric cooler and feedback system. Also, the diode current is regulated, so that a constant output power can be maintained. Both diode temperature and output power are user adjustable. An electrically controlled shutter is used to turn the beam on and off. Finally, a lens is provided to correct for astigmatism in the diode's output.

The beam from the above-mentioned diode system is expanded and collimated before passing through a polarizing beam-splitter cube. This device splits the beam into polarized signal and reference components.

The signal component is reflected from the LCLV where it is modulated by the input image. The modulated signal beam is focused by the Fourier transform lens onto the filter plane where a shadow mask and matched filter assembly are located. This lens effectively projects the Fourier transform of the input image onto the filter plane. A lens for regeneration of the input image is positioned after the filter plane, and a small CCD television camera is provided to capture it. The camera's output can be displayed on a monitor and used by the operator as a guide when adjusting system parameters.

The reference component emanating from the beam splitter cube is directed by mirrors M_1 and M_2 onto the shadow mask. This mask allows only a small rectangular region of the filter plane to be illuminated by the reference energy. The above-mentioned Fourier transform is also projected within this rectangle. The interference pattern between transform and reference signals can be recorded on a photographic plate positioned in the filter plane. The exposure which results is known as a Fourier transform hologram, and it serves as a spatial frequency domain implementation of the classical matched filter for the input image. A precision mount located in the filter plane is provided. The mount accepts rigid stainless steel photographic plate holders which are held in place by small, powerful magnets. A glass photographic plate (2×2 inches) can be glued to each holder.

The photographic plate mount is located on a precision translation stage. The location of this stage within the two-dimensional filter plane is controllable by stepper

motors; the system has one micrometer positional resolution. Hence, the actual place of exposure on a photographic plate can be controlled, and exposures at multiple locations on a plate can be made. The signal energy always has a normal angle of incidence on the photographic plate independent of the location on the plate being exposed.

Mirror M_2 can be rotated about two axis by stepper motors. These degrees of freedom are used to adjust the direction from which the reference beam impinges on the filter plate mask when a matched filter is made. This direction is important when correlating the filter against a normal incidence image transform signal since the resulting correlation ray exits the filter in this same direction. That is, the correlation and reference beams appear to be co-axial. As discussed in Section III, when multiple filters are made on the same plate the associated reference directions are selected so that the correlation rays appear to be parallel.

The four stepper motors which control filter plate position and mirror M_2 orientation are driven by digital programmable controllers. An IBM PC serves as a user-interface to the system, and it commands the programmable controllers. The number of exposures, the location of the exposures, and the reference energy direction at an exposure are all under computer control. During normal operation of the filter maker these parameters are controlled by a Basic language program running on the PC which prompts the user for input in addition to reading data from disk. It is possible to make copies of the same hologram at different locations on the photographic plate, or if desired, use a different input image at each location.

A self calibration feature is built into the above-mentioned software. To use this feature an apparatus containing a quadrature photodetector cell is placed on the photographic plate mount. The photodetector's outputs are converted into a computer usable form by an analog-to-digital converter. The computer uses this data to establish an absolute positional reference for alignment purposes. This procedure is used to compensate for filter misalignment due to filter maker temperature changes and normal

wear.

The filter maker is to be used to make matched filters for use with the correlator described in Section III. To fully exploit the correlator the filter maker must be programmed to make 30 exposures on the photographic plate. The exposures are arranged in two 5 x 3 arrays as shown by Figure 3. The actual locations of the exposures on the plate are selected to match the point foci of the correlator as discussed in Section III. A design goal of the correlator was the ability to correlate simultaneously an input image with 30 matched filters on a single photographic plate exposed by the filter maker.

The filter maker itself can be used as a simple correlator to compare an input image displayed on the TV projector with a matched filter stored on a photographic plate. Just adjust the system so that the modulated (with the input image) signal beam is aligned with the matched filter, and move mirror M_3 so that it reflects the reference beam (passing through the filter plane) into the TV camera's field of view. Block the reference beam at M_1 (put a piece of black cardboard in front of this mirror), and observe the correlation on a monitor connected to the camera. This procedure should be used to test matched filters manufactured with the filter maker.

III. A COMPACT CORRELATOR

A small, compact correlator is described in this section. All correlator components, except for the imaging lens and power supply, are packaged into a cylinder 15cm in diameter and 30.5cm long. An adjustable focal length lens (35mm to 200mm) for imaging an input scene was used with the correlator. This adjustment could be used by the operator to effect a change of scale in the input image. An external power supply capable of supplying $\pm 12\text{VDC}$ at .2 amps and $+5\text{VDC}$ at 5 amps is required for operation of the correlator. Design goals for the correlator are listed in Table 1.

Figures 4 and 5 depict the correlator's basic layout. Figure 4 is used below to describe the path through the correlator taken by the laser light before it is modulated by

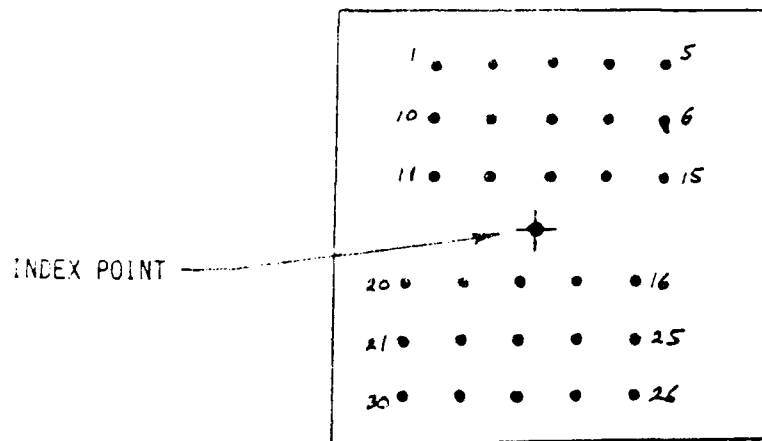

Figure 3. Diagram depicting the nominal exposure pattern of the filter maker and the point foci pattern of the correlator.

TABLE 1. A Listing of Correlator Design Specifications and Design Goals

Size:	15.3 cm diameter x 30.5 cm long
Weight (estimated):	15 lbs.
Number of filter positions:	30
Input:	direct imaging
Image brightness range (with attenuators):	dusk to full sunlight
Input image resolution:	8 lines/mm
Response time:	1 second
Internal laser diode light source:	
Power rating:	30 mw
Wavelength:	780 nm
Model:	Sharp LT024MF
Number of diodes:	2
Lens mount:	standard Nikon bayonet
Imaging lens:	35 to 200 mm focal length
Correlator output:	composite video signal
Power requirements:	+5V, 5 amp. ± 12V, 0.2 amp.
Power supply	
Input:	120V, 50 Hz
Controls:	Power On/Off Laser diode #1 On/Off Laser diode #2 On/Off

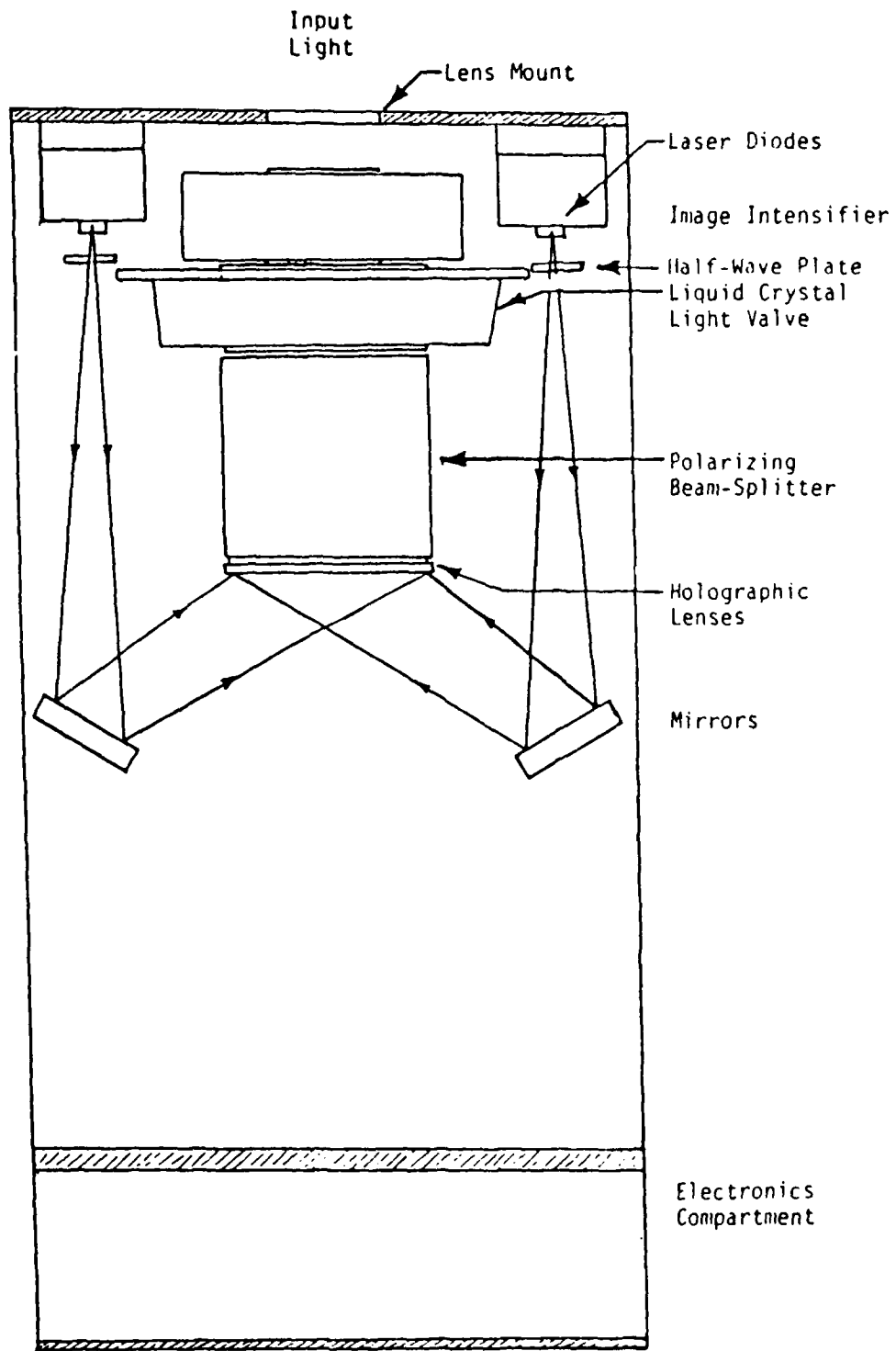

Figure 4. Correlator layout showing elements utilized before laser light modulation.

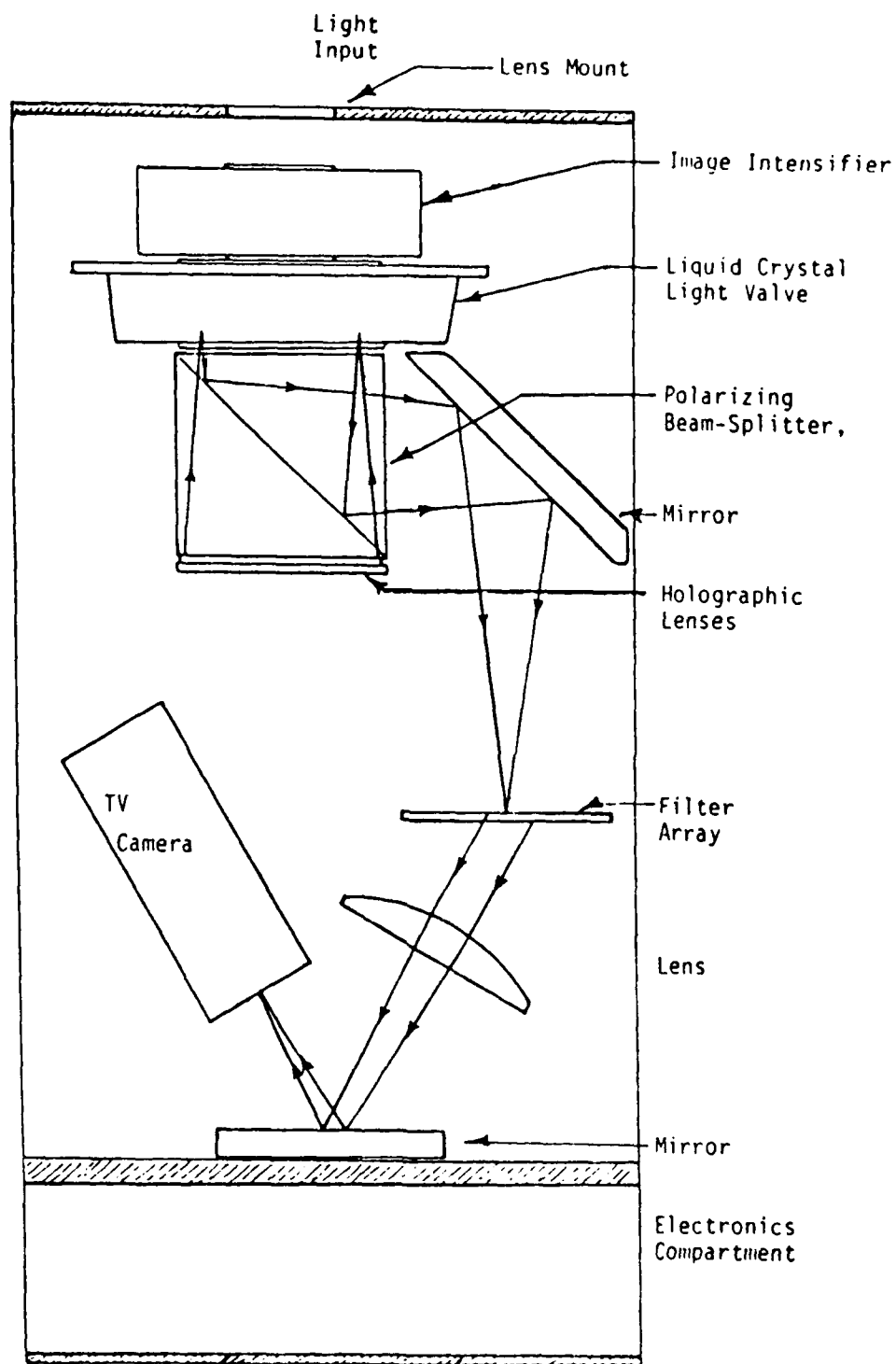

Figure 5. Correlator layout showing elements utilized after laser light modulation.

the LCLV. The path taken by the light after it is modulated is described by use of Figure 5.

The correlator's coherent light is supplied by two laser diodes as shown on Figure 4. Each diode has a nominal output of 30mw and a nominal wavelength of 780nm. The energy from each diode is directed towards an associated holographic optical element (HOE) lens doublet glued on one end of the polarizing beam splitter tube illustrated in Figure 4.

The detailed operation of the holographic lens is complicated, and it cannot be described fully here (see [1]). However, a macroscopic, systems-type description of lens operation can be given. In effect, each lens utilizes the energy from its diode (and only its one diode) to simulate 15 separate converging beams with all focal points positioned in a 3 x 5 array of points in a plane common to all 30 points (15 from each lens) as illustrated by Figure 3. The plane containing the point foci is labeled "Filter Array" in Figure 5. Furthermore, the 15 beams appear to have parallel axes. The two laser diodes in Figure 4 illuminate the stacked HOE and excite 30 converging beams (all axes appear to be parallel) with point foci in the filter array plane depicted on Figure 5.

The 30 point foci mentioned above have fixed positions on the correlator's filter array plane. These positions can be measured and programmed into the filter maker's computer. The goal of this procedure is to have the filter maker position its Fourier transform filters on the photographic filter plate at locations which agree with the correlator's point foci when this plate is inserted into the correlator and positioned on the filter array plane.

Each of the above-mentioned converging beams are reflected from and modulated by the LCLV. Figure 5 serves to illustrate the path taken by one of the beams; the remaining beams behave in a similar manner. Note that the point focus of the beam is on the filter array where it addresses one of the 30 matched filters recorded by the filter maker. The matched filter diffracts the beam and produces a correlation beam which is

directed towards the TV camera. This produces a bright spot on the screen of a monitor connected to the camera.

A design goal of the correlator was to have parallel correlation rays emanating from the 30 filter positions. This can be achieved by judiciously choosing the directions from which the reference beams come when they illuminate their filter positions during the sequenced exposure of the matched filter plate in the filter maker. As discussed in Section II, these reference beam directions are determined by the computer-controlled two degrees of freedom built into mirror M_2 (see Figure 2).

Each of the above-mentioned correlation beams consists of simple collimated light having no focusing power of its own. This is true because each matched filter was recorded with a collimated reference beam.

A simple glass lens is used to collect and focus the correlation rays emerging from the filter plane. This lens is illustrated on Figure 5, and it performs the inverse Fourier transform operation depicted by Equation (I-2). A design goal of the correlator was to have all correlation rays focus to the same location on the CCD element of the TV camera.

The correlator is capable of imaging targets illuminated by very low light levels. To achieve this capability a micro-channel plate image intensifier is mounted on the correlator's image input port (the intensifier tube is not shown on Figures 4 and 5). The gain of the image intensifier is approximately 1.5×10^4 .

Undesirable side effects which result from use of an image intensifier are a decrease in correlator temporal response and spatial resolution. The relatively low intensifier output brightness requires an LCLV bias setting that reduces its response time to about one second. Also, the intensifier lowers the correlator's resolution from a value established by the LCLV (~ 30 lines/millimeter) to approximately 8 l/mm.

IV. EXPERIMENTAL RESULTS

A major goal of the effort culminating in this report was to get the filter maker and correlator operational to the point where matched filters could be manufactured and correlations could be performed. This goal has been met; it is felt that experimental results have been obtained which are at the performance envelope of the system in its present configuration.

Matched filter arrays were recorded using a high contrast black on white 18 cycle (18 black spokes) sector star target as the input image. The same target was used for each filter in order to compare the performance of each element in the array. These filters were bleached with iodine to improve their efficiency.

As discussed in the section on correlator design, a single element, 50mm diameter, 100mm focal length lens was used for the inverse FT lens. Although the correlation spots could be detected using this lens they were extremely weak. A 16mm focal length, $f/1.4$ camera lens was used on the correlator's output camera to decrease the correlation spot size and increase the intensity. This lens also reduces the optical noise by improving light baffling and reducing the field of view of the camera.

Figure 6 depicts typical results obtained for one filter bank of the correlator. Fifteen correlation spots are clearly visible on the photograph. Image lighting and placement were adjusted to optimize the results obtained. The incident light level on the target was 15 foot candles (room light) to yield a target luminance of 2.7 foot lamberts. The correlator input lens was set at $f/22$. For most applications of this correlator the reference beam angles would be chosen during filter recording to make the spots coincide. However, for evaluation and demonstration of correlator performance the reference beam angles were chosen to display each individual filter.

A desktop computer with a TV frame grabber was used to digitize the correlator video output. Available software allowed any part of the image to be analyzed and plotted. Figure 7 depicts the fifteen correlation spots seen on the monitor. This plot was obtained

by windowing the area of interest in Figure 6 and copying it to disk. A three dimensional graphics program read this data and made the plot. Figure 8 depicts one of the brighter correlation spots.

Correlation on targets at low illumination levels was also demonstrated. The light incident on the sector star target was reduced to 0.5 foot candles and the target luminance was measured to be 7.8×10^{-2} foot lamberts. With the correlator input lens set at $f/3.8$ the correlation plane appeared similar to Figure 6 but with decreased correlation spot intensity. A three dimensional plot of one of the brighter correlation spots is shown in Figure 9.

Correlations were also obtained using aerial photographs, however the results were inferior to those achieved with the sector star pattern. The primary reason for this poor performance was that the combined resolution of the image intensifier-LCLV input system was unable to resolve the detail in the photographs.

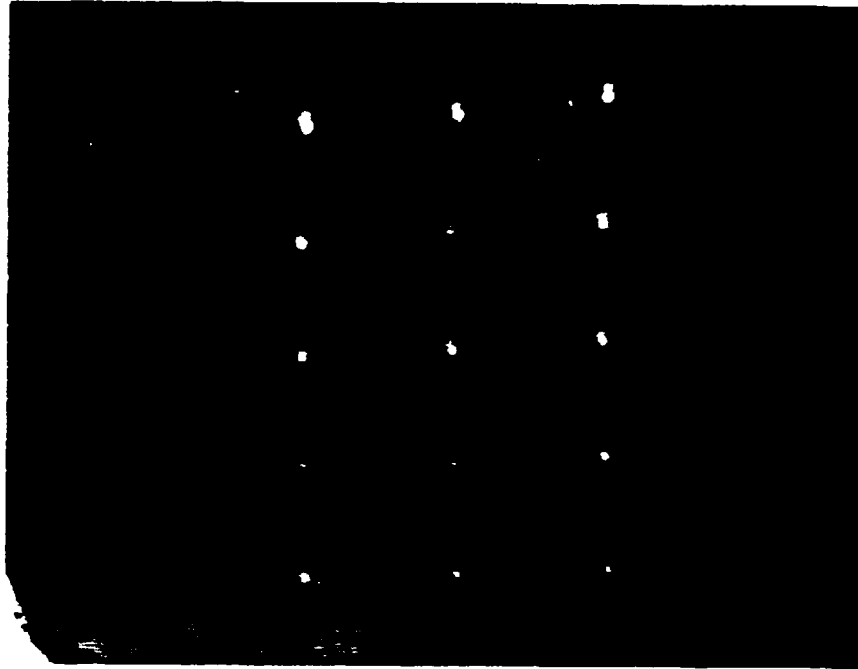

Figure 6. Results obtained from the correlator.
(An input image consisting of a simple radial spoke pattern was correlated with 15 identical matched filters constructed from the input image.)

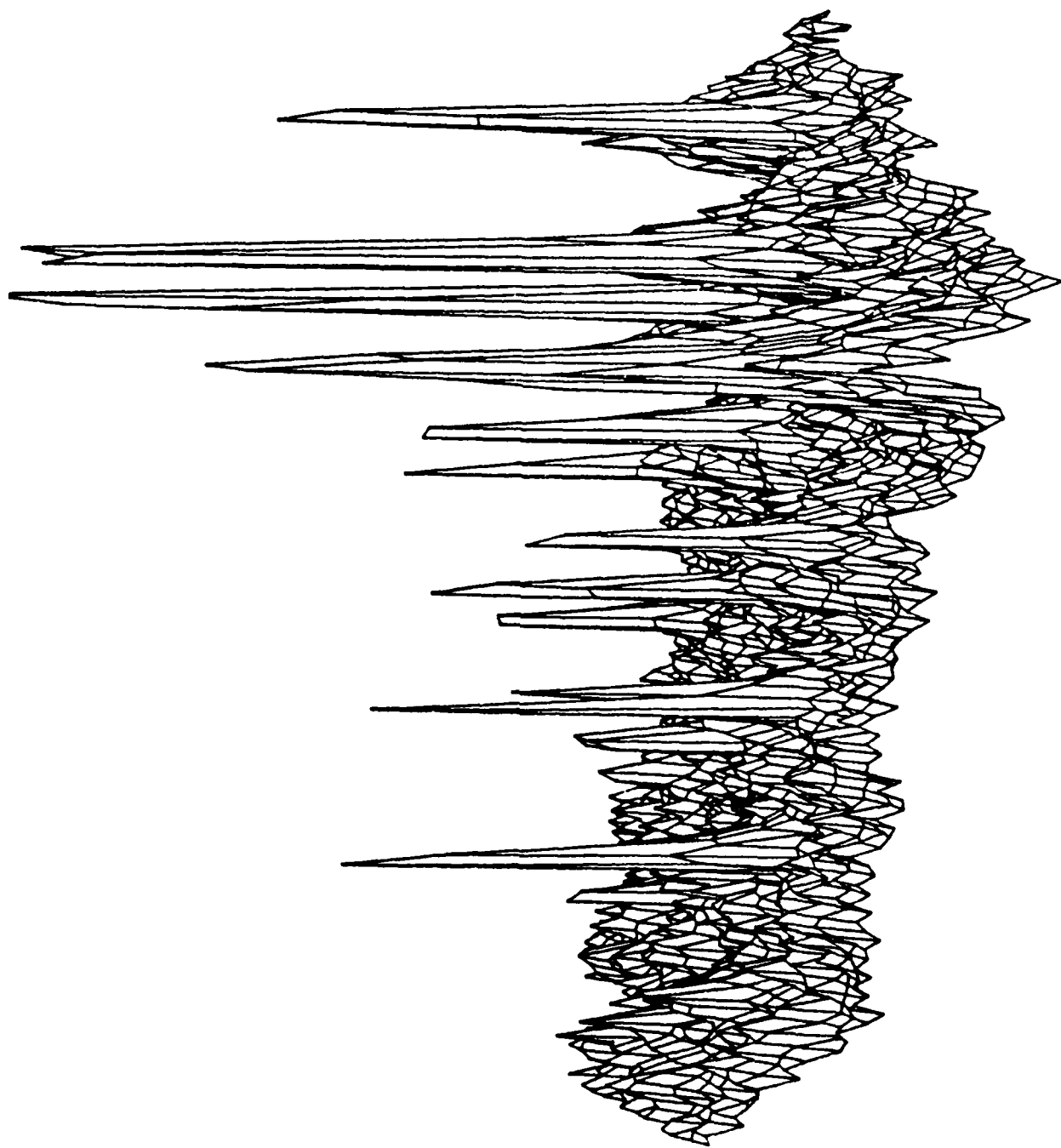

Figure 7. Three dimensional plot of the correlator output shown in Figure 6.

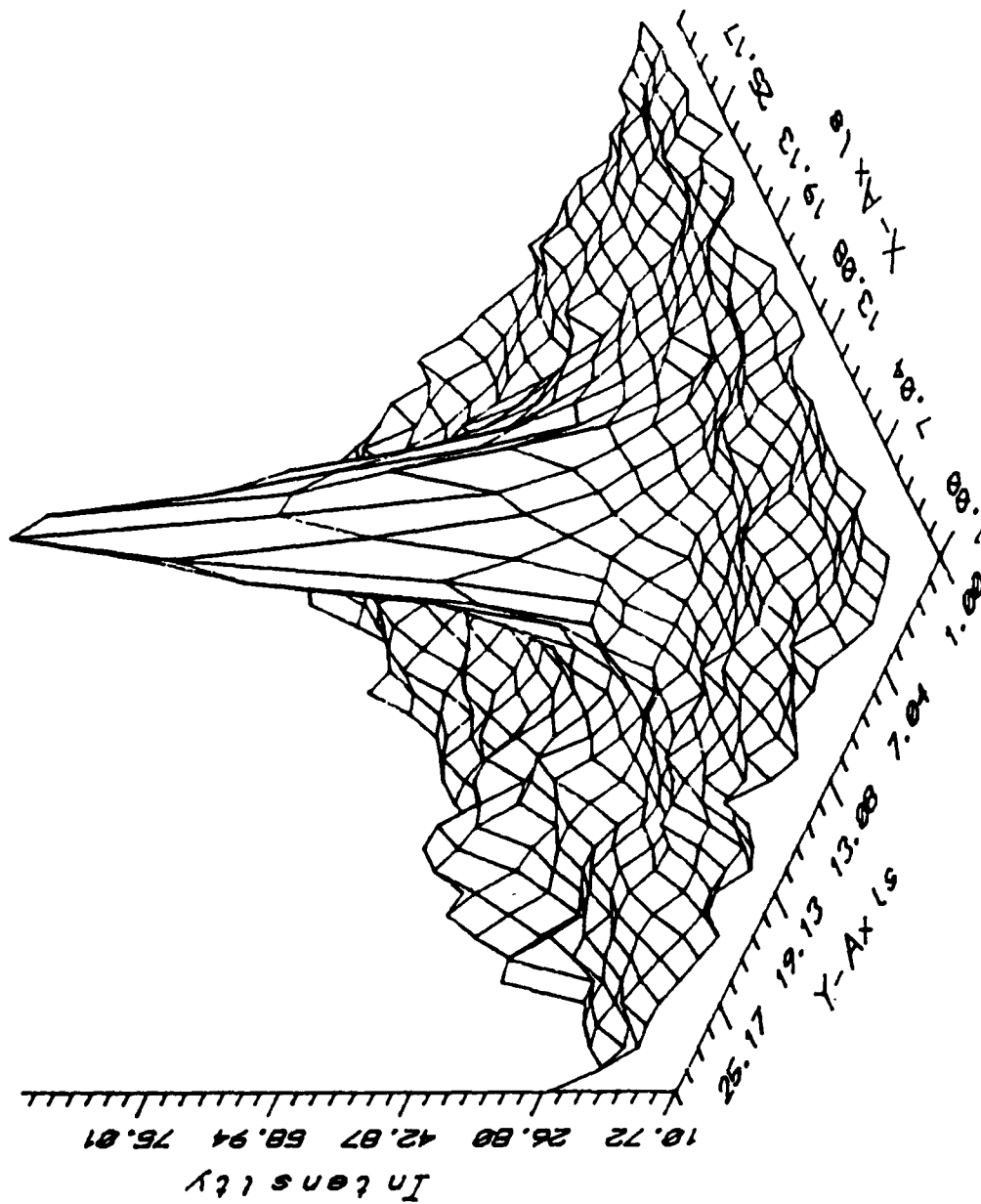

Figure 8. Three dimensional plot of one correlation spot.

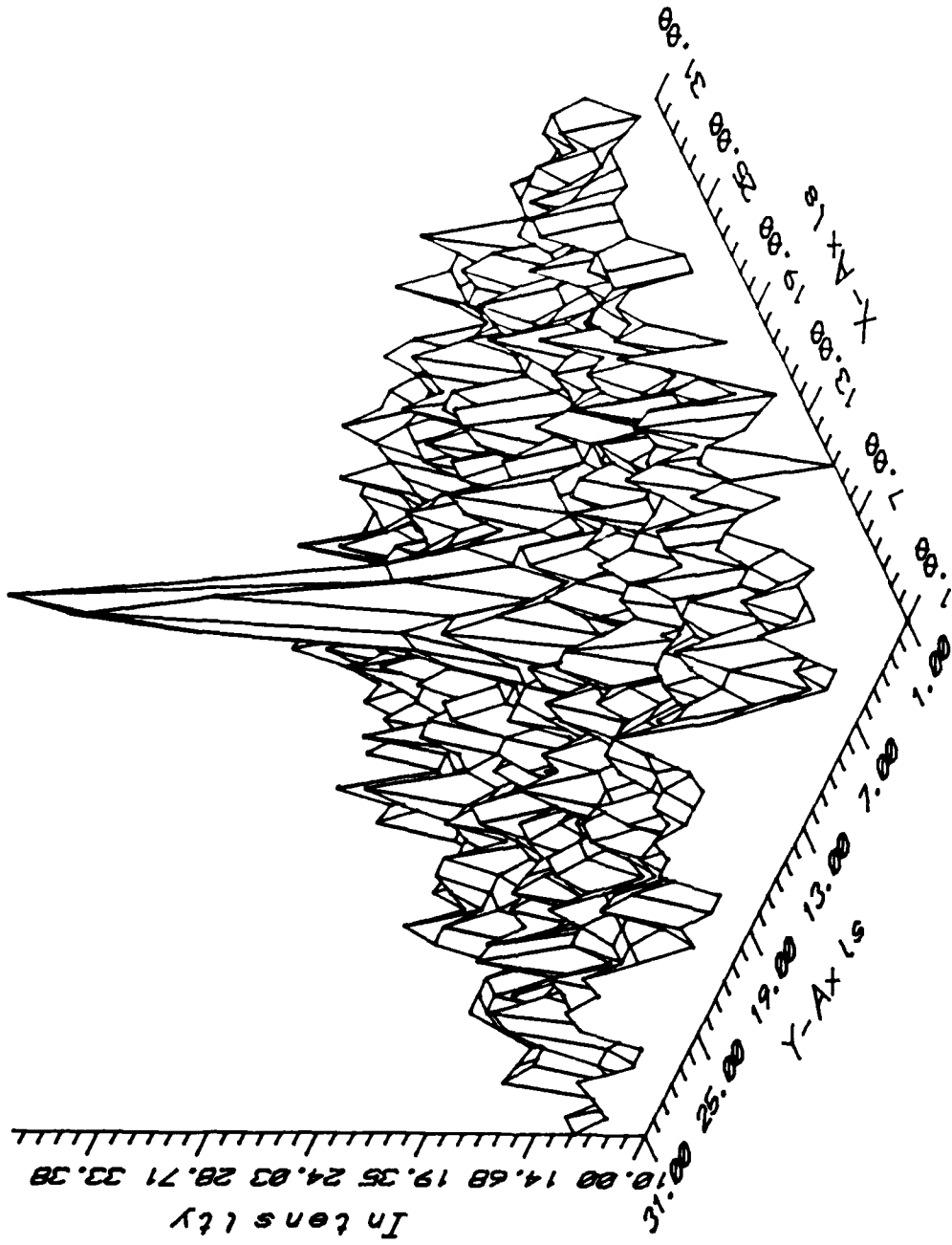

Figure 9. Plot of a correlation spot with the target illumination reduced to 0.5 foot candles.

V. CONCLUSIONS

A compact, coherent, real-time optical correlator and matched filter maker was described. The system was designed to perform multiple simultaneous correlations of an input image scene captured by an ordinary 35mm lens with up to 30 matched filters stored as Fourier transform holograms on a simple photographic glass plate. The correlator's output is a standard composite video signal which can be displayed on a simple monitor. The correlator was designed to work over a wide range of input light levels spanning full sunlight to dusk. The matched filter maker was designed to be computer controlled and to have a self calibration feature.

Experimental results obtained with the system were given. These included a photograph depicting the correlation of an image obtained from a standard radial spoke pattern with 15 identical matched filters manufactured from this image. Correlations were obtained over a wide range of incident light levels spanning full room light (15 foot candles and above) down to .5 foot candles.

Several problems encountered with the system were described. A thermal stability problem is summarized below. The most serious problem encountered involved the process of directing onto the correlator's TV camera the diffracted light from the matched filter plane (the so called "correlation rays"). This light has a very low irradiance; if it is not focused properly it will not be detected by the camera. A possible solution to this problem of low irradiance is to build focusing power into the correlation rays. This may be accomplished by using a focused reference in the manufacture of the matched filters. Unfortunately, a reference with different focal length would have to be used in the manufacture of each filter, and the process would not be trivial. An easier solution might be to increase the irradiance from the correlation process by increasing laser diode power output, or by improving matched filter efficiency.

Correlator alignment drift with changes in temperature is a problem. Significant temperature changes in the operating environment cause contraction/expansion of the

system and a degradation in optical alignment. For reliable, repeatable, long term operation the system should be operated in a constant temperature environment.

Several novel design concepts were incorporated into the correlator and filter maker discussed in this report. It is felt that the system represents an advancement in the state of the art of coherent optical correlator design.

REFERENCES

1. J. Upatnieks, J. Abshier, *Compact Coherent Optical Correlator System*, Report Number 190200-51-F, May, 1988. Environmental Research Institute of Michigan, Ann Arbor, MI.
2. P. Reif, A. Jacobson, W. Bleha, and J. Grinberg, *Hybrid Liquid Crystal Light Valve-Imaging Tube Devices for Optical Data Processing*, SPIE Vo.. 83, Optical Information Processing, p. 34-43, 1976.

	<u>No. of Copies</u>
Director U.S. Army Research Office ATTN: SLCRO-PH P.O. Box 12211 Research Triangle Park, NC 27709-2211	1
Director U.S. Army Research Office ATTN: SLCRO-ZC P.O. Box 12211 Research Triangle Park, NC 27709-2211	1
Headquarters Department of the Army ATTN: DAMA-ARR Washington, DC 20310-0632	1
Headquarters OUSDR&E ATTN: Dr. Ted Berlincourt The Pentagon Washington, DC 20310-0632	1
IIT Research Institute ATTN: GACIAC 10 W. 35th Street Chicago, IL 60616	1
U.S. Army Materiel System Analysis Activity ATTN: AMXSU-MP Aberdeen Proving Ground, MD 21005	1
Defense Advanced Research Projects Agency Defense Sciences Office Electronics Systems Division ATTN: Dr. John Neff 1400 Wilson Boulevard Arlington, VA 22209	1
Commander U.S. Army Foreign Science and Technology Center AIAST-RA 220 Seventh Street NE Charlottesville, VA 22901-5396	1

DIST-1

DISTRIBUTION (Continued)

	<u>Copies</u>
Commander U.S. Army Strategic Defense Command DASD-H-V P.O. Box 1500 Huntsville, AL 35807-3801	1
Director, URI University of Rochester College of Engineering and Applied Science The Institute of Optics Rochester, NY 14627	1
Director, JSOP University of Arizona Optical Science Center Tucson, AZ 85721	1
AMSMI-RD, Dr. McCorkle	1
Dr. Stephens	1
Dr. Rhoades	1
AMSMI-RD-RE, Dr. R. Hartman	1
AMSMI-RD-RE, Dr. J. Bennett	1
AMSMI-RD-RE-OP, Dr. Christensen	50
AMSMI-RD-CS-R	15
AMSMI-RD-CS-T	1
AMSMI-GC-IP, Mr. Bush	1

END
FILMED
6-89
DTIC