

2

TECHNICAL REPORT HL-89-5

DUTCH GULCH OUTLET WORKS COTTONWOOD CREEK, CALIFORNIA

Hydraulic Model Investigation

by

W. G. Davis

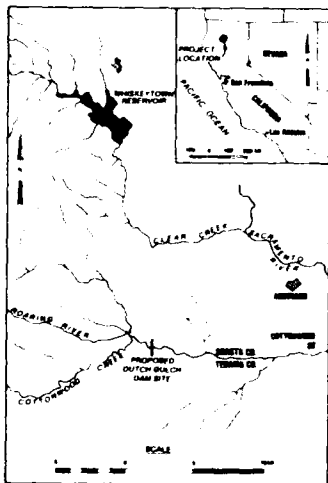
Hydraulics Laboratory

DEPARTMENT OF THE ARMY
Waterways Experiment Station, Corps of Engineers
PO Box 631, Vicksburg, Mississippi 39181-0631



US Army Corps
of Engineers

AD-A208 037



April 1989

Final Report

Approved For Public Release: Distribution Unlimited

DTIC
ELECTE
MAY 23 1989
S H D
Cb



Prepared for US Army Engineer District, Sacramento
Sacramento, California 95814-4794

050

Destroy this report when no longer needed. Do not return
it to the originator.

The findings in this report are not to be construed as an official
Department of the Army position unless so designated
by other authorized documents.

The contents of this report are not to be used for
advertising, publication, or promotional purposes.
Citation of trade names does not constitute an
official endorsement or approval of the use of
such commercial products.

Unclassified

SECURITY CLASSIFICATION OF THIS PAGE

REPORT DOCUMENTATION PAGE				Form Approved OMB No. 0704-0188	
1a. REPORT SECURITY CLASSIFICATION Unclassified		1b. RESTRICTIVE MARKINGS			
2a. SECURITY CLASSIFICATION AUTHORITY		3. DISTRIBUTION / AVAILABILITY OF REPORT			
2b. DECLASSIFICATION / DOWNGRADING SCHEDULE		Approved for public release; distribution unlimited.			
4. PERFORMING ORGANIZATION REPORT NUMBER(S) Technical Report HL-89-5		5. MONITORING ORGANIZATION REPORT NUMBER(S)			
6a. NAME OF PERFORMING ORGANIZATION USAEWES Hydraulics Laboratory	6b. OFFICE SYMBOL (if applicable) CEWES-HS-L	7a. NAME OF MONITORING ORGANIZATION			
6c. ADDRESS (City, State, and ZIP Code) PO Box 631 Vicksburg, MS 39181-0631		7b. ADDRESS (City, State, and ZIP Code)			
8a. NAME OF FUNDING / SPONSORING ORGANIZATION USAED, Sacramento	8b. OFFICE SYMBOL (if applicable)	9. PROCUREMENT INSTRUMENT IDENTIFICATION NUMBER			
8c. ADDRESS (City, State, and ZIP Code) 670 Capitol Mall Sacramento, CA 95814-4794		10. SOURCE OF FUNDING NUMBERS			
		PROGRAM ELEMENT NO.	PROJECT NO.	TASK NO.	WORK UNIT ACCESSION NO.
11. TITLE (Include Security Classification) Dutch Gulch Outlet Works, Cottonwood Creek, California; Hydraulic Model Investigation					
12. PERSONAL AUTHOR(S) Davis, W. G.					
13a. TYPE OF REPORT Final report	13b. TIME COVERED FROM _____ TO _____	14. DATE OF REPORT (Year, Month, Day) April 1989	15. PAGE COUNT 62		
16. SUPPLEMENTARY NOTATION Available from National Technical Information Service, 5285 Port Royal Road, Springfield, VA 22161.					
17. COSATI CODES			18. SUBJECT TERMS (Continue on reverse if necessary and identify by block number)		
FIELD	GROUP	SUB-GROUP	Dutch Gulch Dam Stilling basins		
			Hydraulic models		
			Outlet works		
19. ABSTRACT (Continue on reverse if necessary and identify by block number)					
<p>The intake structure of the proposed Dutch Gulch Dam will provide effective regulation of both flood-control and water quality releases. The model investigation of the outlet works for the proposed structure was concerned with verification and improvement of the hydraulic design of the intake structure, conduit, and stilling basin. The study was conducted in a 1:25-scale model of the outlet works, which reproduced a portion of the approach area, the intake structure, the outlet conduit, the hydraulic jump type stilling basin, and approximately 400 ft of exit channel. Pressure flow occurred in the turbine exit chamber for turbine releases greater than 600 cfs. Enlarging the exit chamber portal and streamlining the portal invert should result in greater turbine releases under partial flow conditions. The conduit experienced slug flow for a wide range of flood-control discharges, which created surges in the stilling basin and exit channel. The conduit was</p> <p style="text-align: right;">(Continued)</p>					
20. DISTRIBUTION / AVAILABILITY OF ABSTRACT <input checked="" type="checkbox"/> UNCLASSIFIED/UNLIMITED <input type="checkbox"/> SAME AS RPT <input type="checkbox"/> DTIC USERS			21. ABSTRACT SECURITY CLASSIFICATION Unclassified		
22a. NAME OF RESPONSIBLE INDIVIDUAL			22b. TELEPHONE (Include Area Code)	22c. OFFICE SYMBOL	

Unclassified

SECURITY CLASSIFICATION OF THIS PAGE

19. ABSTRACT (Continued).

vented, resulting in a significant reduction of the range of discharges for which slug flow occurred. Pressures were positive throughout the intake structure for all discharges observed. Performance of the original design exit channel was inadequate, resulting in significantly higher tailwaters than expected. As a result of model tests, changes were made in the design of the exit channel to pass the desired discharges. The stilling basin baffle piers were also modified in accordance with Engineer Manual 1110-2-1602, "Hydraulic Design of Reservoir Outlet Structures." Performance of the type 2 design exit channel and stilling basin provided adequate energy dissipation and flow conditions for all discharges (excluding slug flow) observed.

Unclassified

SECURITY CLASSIFICATION OF THIS PAGE

PREFACE

The model investigation reported herein was authorized by Headquarters, US Army Corps of Engineers, on 9 March 1984 at the request of the US Army Engineer District, Sacramento (SPK).

The study was conducted by personnel of the Hydraulics Laboratory, US Army Engineer Waterways Experiment Station (WES), during the period December 1984 to March 1987. All studies were conducted under the direction of Messrs. F. A. Herrmann, Jr., Chief of the Hydraulics Laboratory, and J. L. Grace, Jr., and G. A. Pickering, past and present Chiefs, respectively, of the Hydraulic Structures Division. The model components were constructed and assembled by Messrs. E. B. Williams and W. R. Landers, Engineering and Construction Services Division, WES. The tests were conducted by Messrs. W. G. Davis and M. P. Thomas, Locks and Conduits Branch, under the supervision of Messrs. G. A. Pickering and J. F. George, past and present Chiefs, respectively, of the Locks and Conduits Branch. This report was prepared by Mr. Davis and edited by Mrs. M. C. Gay, Information Technology Laboratory, WES.

During the course of the investigation, Mr. D. DiBuono of the US Army Engineer Division, South Pacific, and Messrs. H. Huff, C. Mifkovic, and S. Freitas of SPK visited WES to discuss model results and correlate these results with current design work.

COL Dwayne G. Lee, EN, is the Commander and Director of WES.
Dr. Robert W. Whalin is the Technical Director.



Accession For	
NTIS GRA&I	<input checked="" type="checkbox"/>
DTIC TAB	<input type="checkbox"/>
Unannounced	<input type="checkbox"/>
Justification	
By _____	
Distribution/	
Availability Codes	
Dist	Avail and/or Special
A-1	

CONTENTS

	<u>Page</u>
PREFACE.....	1
CONVERSION FACTORS, NON-SI TO SI (METRIC) UNITS OF MEASUREMENT.....	3
PART I: INTRODUCTION.....	5
The Prototype.....	5
Purpose and Scope of Model Investigation.....	6
PART II: THE MODEL.....	7
Description.....	7
Model Appurtenances.....	7
Design Considerations.....	7
Scale Relations.....	10
PART III: TESTS AND RESULTS.....	11
Flood-Control Conduit, Original Design.....	11
Water Quality Conduits	12
Turbine Releases.....	12
Stilling Basin.....	13
Shortened Flood-Control Conduit.....	14
PART IV: CONCLUSIONS AND RECOMMENDATIONS.....	15
TABLES 1-5	
PHOTOS 1-8	
PLATES 1-30	

CONVERSION FACTORS, NON-SI TO SI (METRIC)
UNITS OF MEASUREMENT

Non-SI units of measurement used in this report can be converted to SI (metric) units as follows:

<u>Multiply</u>	<u>By</u>	<u>To Obtain</u>
acres	4046.856	square metres
acre-feet	1,233.489	cubic metres
cubic feet	0.02831685	cubic metres
feet	0.3048	metres
feet of water (39.2° F)	2,988.98	pascals
miles (US statute)	1.609344	kilometres

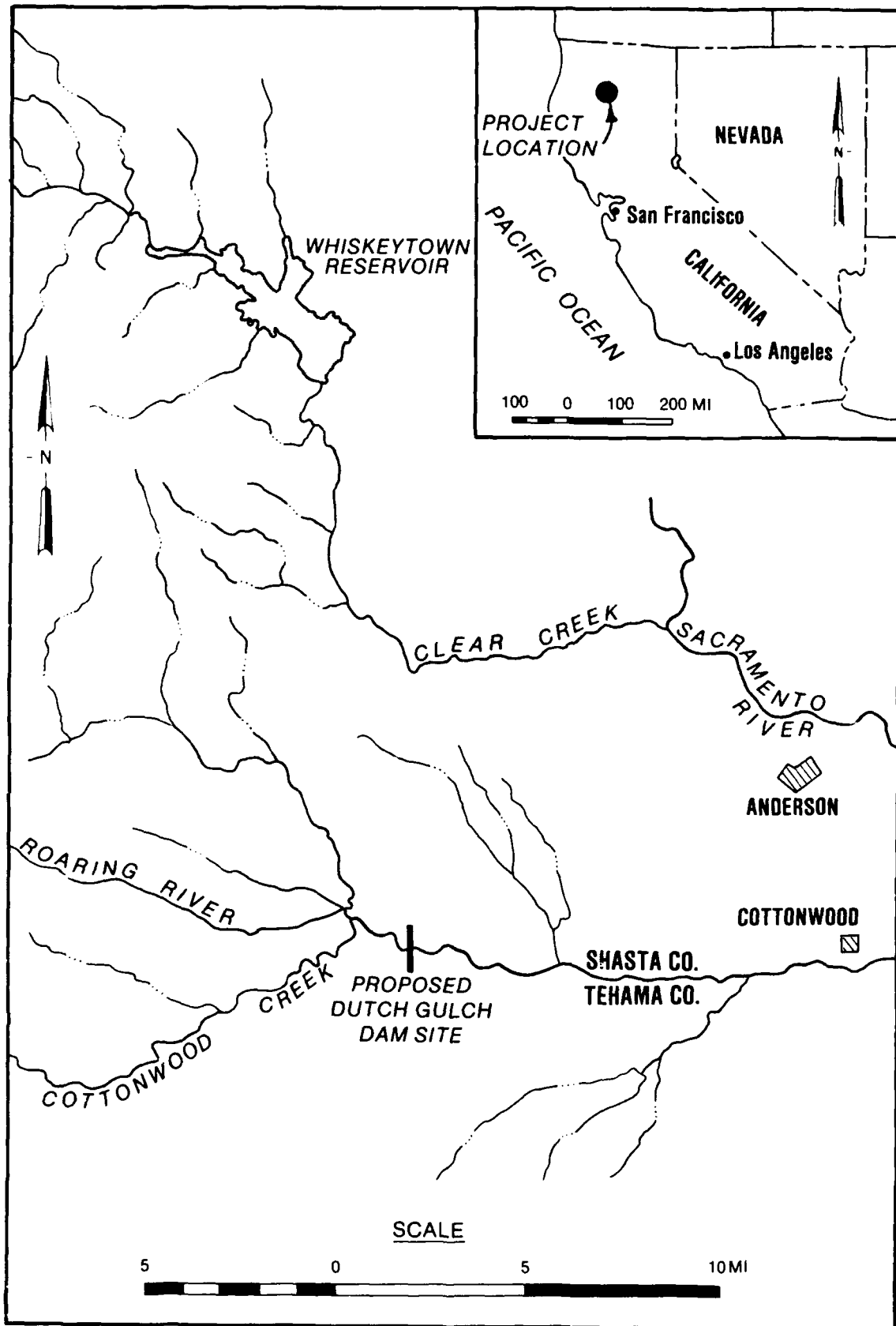


Figure 1. Project locations and vicinity map

DUTCH GULCH OUTLET WORKS, COTTONWOOD CREEK, CALIFORNIA

Hydraulic Model Investigation

PART 1: INTRODUCTION

The Prototype

1. Dutch Gulch Lake and outlet works, as proposed, would be located on the main stem of Cottonwood Creek about 11 miles* west of the town of Cottonwood, CA (Figure 1). The lake would store runoff from the north and middle forks of Cottonwood Creek with a storage capacity of 900,000 acre-ft, a surface area of 11,200 acres, a length of approximately 8 miles, and a maximum depth of 228 ft at gross pool elevation of 740 ft**.

2. The primary functions of Dutch Gulch Lake would be to provide flood control, municipal and industrial water supply, recreation, and fish and wildlife enhancement.

3. The outlet works, located adjacent to the right abutment, would consist of an approach channel, intake structure, control tower, conduit transition, conduit, stilling basin, and exit channel. A general plan of the project is shown in Plate 1. The single 14-ft-diam conduit, 1,424 ft long, will be constructed of concrete of the cut-and-cover type. Two 6.5- by 14-ft flood-control passages controlled by hydraulically operated slide gates will provide operational regulation. The control tower will be of the multiple-level intake type with dual wet wells to provide for temperature control of downstream releases. Three turbines are incorporated into the structure for future power generation. Units 1 and 2 are horizontal Francis turbines connected to the right wet well, and Unit 3 is a vertical Francis turbine connected to the left wet well. Each wet well is provided with a bypass conduit which can operate in conjunction with the turbine units or separately if the turbines are inoperable to achieve the design water quality discharge of 1,200 cfs. The turbines would also be operated during flood-control releases.

* A table of factors for converting non-SI units of measurement to SI (metric) units is found on page 3.

** All elevations (el) cited herein are in feet referred to the National Geodetic Vertical Datum (NGVD).

Details of the intake structure are shown in Plate 2. Energy dissipation of the conduit discharge will be accomplished in a conventional hydraulic jump type stilling basin and outflow returned to Cottonwood Creek through a riprap-lined exit channel. Details of the outlet works stilling basin are shown in Plate 3.

Purpose and Scope of Model Investigation

4. A model study was considered necessary to evaluate the hydraulic performance of the intake structure, transition, conduit, stilling basin, and exit channel and to develop modifications to provide satisfactory performance for the range of discharges expected. Specifically the model study was to determine the following:

- a. Discharge rating curves for flood-control and water quality releases.
- b. Adequacy of stilling basin performance throughout the full range of releases.
- c. Flow conditions in the turbine exit chamber for combined turbine releases.
- d. Slug flow characteristics for flood-control and turbine releases.
- e. Flow conditions and pressures throughout the intake structure and conduit for the full range of releases.

PART II: THE MODEL

Description

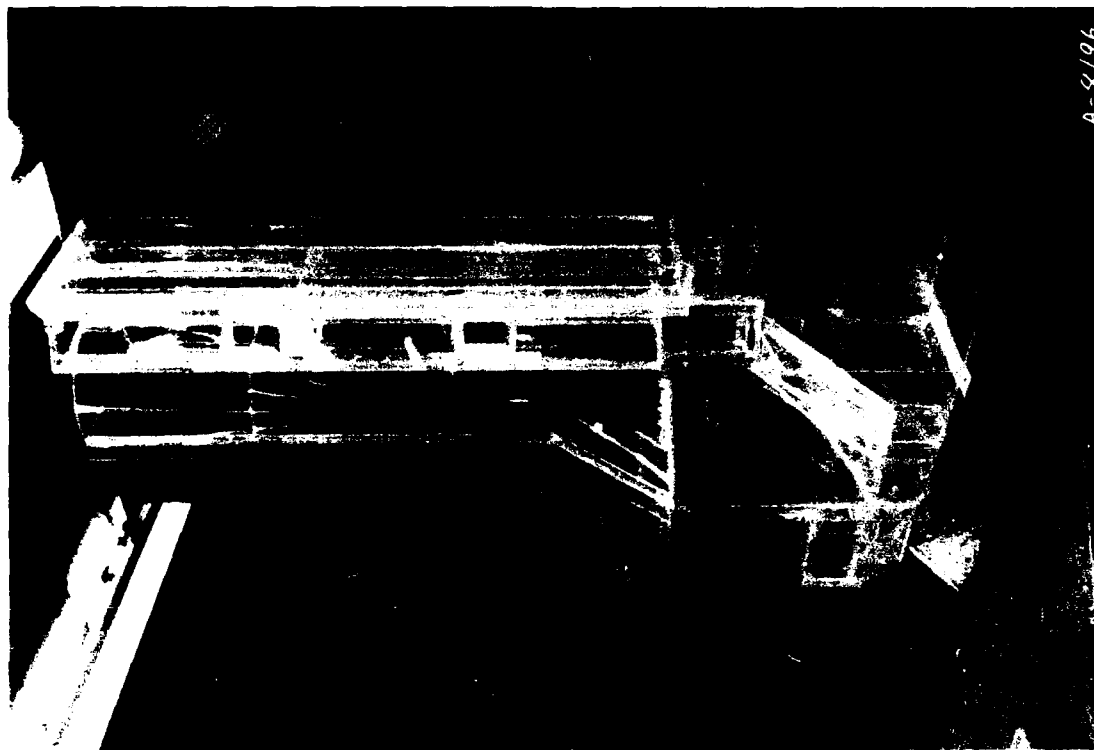
5. The 1:25-scale model reproduced a 250- by 250-ft area of the reservoir, the intake structure, the entire length of conduit, the stilling basin, and about 400 ft of the exit channel (Figures 2 and 3, Plates 1-3). The intake tower, transition, and conduit were constructed of transparent plastic. The headbay box was constructed of wood and waterproofed with a fiberglass liner. Steel rods were used for reinforcement. Approach topography was constructed of plastic-coated plywood. The outlet works stilling basin was constructed of plastic-coated plywood, and the parabolic-shaped trajectory was fabricated from sheet metal and mortar. The exit channel was molded in sand and cement mortar to sheet metal templates.

Model Appurtenances

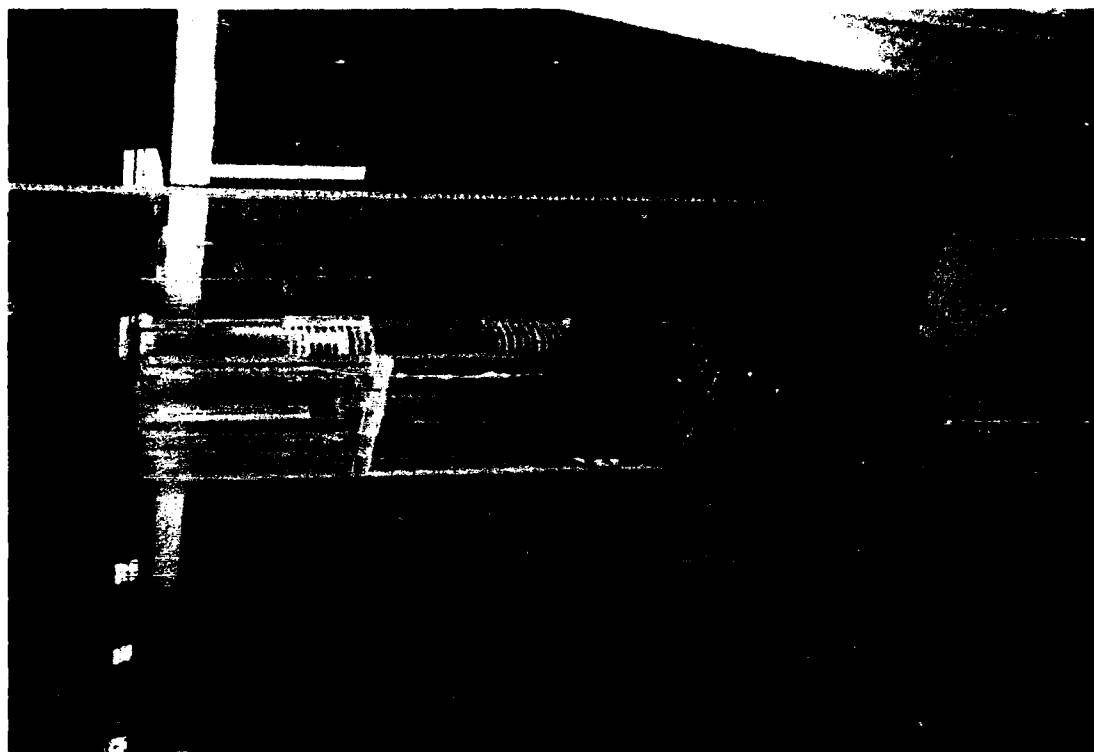
6. Water used in the operation of the model was supplied by a circulating system. Discharges in the model were measured with venturi meters installed in the flow lines and were baffled when entering the model. Water-surface elevations were measured with point gages. Velocities were measured with propeller type meters mounted to permit measurement of flow from any direction and at any depth. Piezometers were installed throughout the model for measurement of average pressures. The tailwater in the lower end of the model was maintained at the desired depth by means of an adjustable tailgate. Different designs, along with various flow conditions, were recorded photographically.

Design Considerations

7. In the design of the model, geometric similitude was preserved between model and prototype by means of an undistorted scale ratio. It is not possible to satisfy the requirements of both the Reynolds and Froude criteria for complete similitude when water is used in the model. Since water is the fluid in the prototype, hydraulic similitude between the model and prototype was based on the Froude relations; and the Reynolds number of the flow in the



a. Prior to installation



b. Installed in model

Figure 2. Intake structure

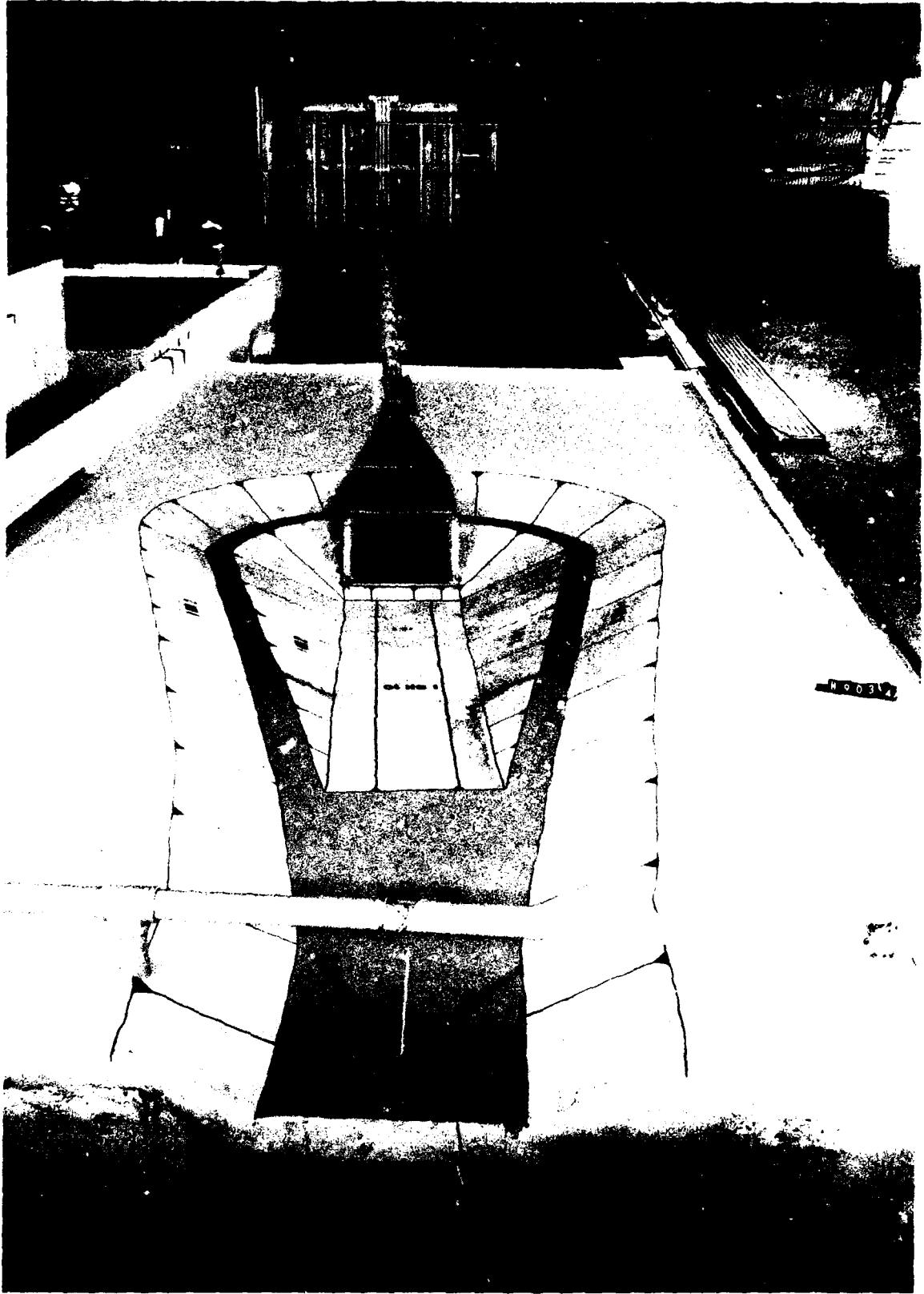


Figure 3. Conduit, stilling basin, and exit channel
looking upstream

model was lower than that of the prototype. Making a valid study of flow conditions in the outlet works required that the hydraulic grade line be simulated accurately in the model and that the entire length of conduit be reproduced to study slug flow. Therefore the resistance coefficient of the model must equal that of the prototype, thus dictating a model scale of 1:25.

Scale Relations

8. The accepted equations of hydraulic similitude, based on the Froude criteria, were used to express mathematical relations between the dimensions and hydraulic quantities of the model and prototype. General relations for the transference of model data to prototype equivalents are presented in the following tabulation:

<u>Characteristic</u>	<u>Dimension*</u>	<u>Scale Relations Model:Prototype</u>
Length	L_r	1:25
Area	$A_r = L_r^2$	1:625
Velocity	$V_r = L_r^{1/2}$	1:5
Discharge	$Q_r = L_r^{5/2}$	1:3,125
Volume	$V_r = L_r^3$	1:15,625
Weight	$W_r = L_r^3$	1:15,625
Time	$T_r = L_r^{1/2}$	1:5

* Dimensions are in terms of length.

Measurements in the model of discharges, water-surface elevations, and velocities can be transferred quantitatively from model to prototype by means of these scale relations.

PART III: TESTS AND RESULTS

Flood-Control Conduit, Original Design

9. The model conduit was constructed to simulate a value of 0.002 ft for the absolute roughness K of the conduit wall. The conduit was designed for a discharge of 10,000 cfs at pool el 725.0. Discharge rating curves were developed for the flood-control passages with flows ranging up to 10,600 cfs and pool elevations ranging from 578 to 748 (Plates 4 and 5). Satisfactory flow conditions were observed in the conduit for partial and full pipe flow. However, at intermediate discharges, air entrained immediately downstream from the service gates formed moving pockets of air, known as slug flow, in the downstream portion of the conduit (Photo 1). The conduit experienced slug flow for a range of gate openings and discharges for both single and dual gate operations with flood-control discharges (Plates 4 and 5). Slug flow conditions that were observed created excessive turbulence and surges in the stilling basin that extended into the exit channel, as shown in Photo 2.

10. Pressures measured throughout the flood-control facilities with the design discharge of 10,000 cfs were positive (Table 1). Piezometer locations are shown in Plate 6. Observations also indicated that pressures were positive with either of the service gates fully open with a reservoir pool at el 725.0 (Table 2).

11. It should be noted that the air vents for the flood-control and water quality service gates in the model were constructed as separate conduits. As originally designed, the air vents were interconnected just above the plenum at approximately el 535.0. Engineer Manual (EM) 1110-2-1602* states that "interconnected air vents (one main vertical stem manifolded to vent more than one gate) should be avoided; but if they are necessary, the connections should be above the maximum possible elevation of the pressure grade line at the air vent exit opening to prevent crossflow of water." The maximum elevation of the pressure grade line at the air vent exit opening observed in the model was 650.0.

* Office, Chief of Engineers, US Army. 1980 (15 Oct). "Hydraulic Design of Reservoir Outlet Works," EM 1110-2-1602, US Government Printing Office, Washington, DC.

Water Quality Conduits

12. The two water quality conduits were designed for a combined partial gate discharge of 1,200 cfs at pool el 745, with 750 cfs through the 3.25-ft-square conduit and 450 cfs through the 3.0-ft-square conduit. Discharge rating curves were also developed for the water quality bypass conduits with flows ranging from partial to full gate opening (Plates 7 and 8). Flow conditions in the vicinity of the transition section just downstream of the intake structure with a combined water quality discharge of 1,200 cfs are shown in Photo 3. The impact of these high-velocity jets on the conduit invert were of concern relative to the placement of construction joints in the prototype; therefore, the points of impact for a range of water quality discharges are given in the following tabulation:

<u>Discharge, cfs</u>		<u>Total</u>	<u>Area of Impact, sta</u>	
<u>3.0- by</u> <u>3.0-ft</u> <u>Conduit</u>	<u>3.25- by</u> <u>3.25-ft</u> <u>Conduit</u>		<u>Initial</u>	<u>Secondary</u>
150	450	600	22+60-22+95	--
300	600	900	22+70-23+00	23+35-23+55
450	750	1,200	22+75-23+05	23+45-23+60

Note: Stations given are for the original design conduit.
To obtain stations for shortened conduit (see paragraph 17), add 45 ft.

13. Observation of design flow conditions through the water quality bypass conduits revealed positive pressures throughout (Table 3).

Turbine Releases

14. At pool el 745, units 1 and 2 would have a combined release capability of 420 cfs and unit 3 would have a release capability of 750 cfs. The turbines would discharge into a common exit chamber. Satisfactory flow conditions were observed in the turbine exit chamber for turbine releases of 600 cfs and less. However, the turbine exit chamber became pressurized for turbine releases greater than 600 cfs. Photo 4 and Plate 2 show flow passages in the vicinity of the turbine exit chamber. Flow conditions with the combined discharge of 1,170 cfs from the three turbines are shown in Photo 5. Slug

flow was present for certain combinations of flood-control and turbine discharges. This flow could cause pressure fluctuations in the draft tube, which could result in surging in the turbines. The ranges of gate openings (flood control) and discharges for combinations of flood-control and turbine releases experiencing slug flow are shown in Plates 9-12. With turbine releases and flood-control discharges, slug flow occurred over a wider range of discharges than with flood-control discharges only. Also, the range of discharges for which slug flow occurred was broader with releases from all three turbines than with releases from turbine unit 3 only. This could be due to the added turbulence created by the differences between the flow velocities of the flood-control and turbine releases and the amount of water released by the turbines. Pressure measurements in the turbine exit chamber recorded with various turbine and combinations of turbine and flood-control releases are shown in Table 4. By enlarging the exit chamber portal and streamlining the portal invert, it is possible that greater turbine discharges could be released under partial flow conditions.

Stilling Basin

15. The stilling basin as originally designed (Plate 3) required certain modifications before basic data such as water-surface profiles and photographs of flow conditions were recorded. These modifications included removing the one-half-sized baffle piers located against the basin sidewalls and interchanging the two rows of baffle piers as suggested in EM 1110-2-1602.* Also, initial tests indicated that the exit channel was not adequate and yielded significantly higher tailwater elevations than expected. The exit channel was redesigned by the US Army Engineer District, Sacramento, and the model was modified to reproduce the tailwater elevations for the new exit channel configuration (type 2 exit channel, Plate 13). The bottom width of the channel was increased from 60 to 90 ft and the invert slope was increased from 0.00 ft/ft to 0.0004 ft/ft. The length of the 1V on 10H adverse slope downstream of the end sill was reduced from 280 to 240 ft, resulting in lowering the exit channel invert by 4 ft, yielding the type 2 design exit channel.

16. With the proper tailwater elevation reproduced, satisfactory flow

* Office, Chief of Engineers, US Army, op. cit.

conditions were observed in the stilling basin for all flood-control discharges (excluding slug flow) observed. Water-surface profiles recorded in the stilling basin and velocities measured over the end sill with flood-control discharges of 1,000, 5,000, and 10,000 cfs are presented in Plates 14-16, respectively. Flow conditions and water-surface elevations for the same discharges are provided in Photo 6 and Table 5. Even though adequate energy dissipation occurred in the stilling basin with the range of tailwater elevations observed, higher exit velocities will occur if the tailwater elevation is several feet lower than design conditions. Flow conditions with a discharge of 10,000 cfs and tailwater elevations approximately 5 ft lower and 5 ft higher than expected are shown in Photo 7.

Shortened Flood-Control Conduit

17. After an evaluation of the dam by the Sacramento District, it was decided that steeper dam embankment slopes should be used, thereby reducing the required length of conduit. Modifications to the conduit included reducing the length by 268.19 ft and steepening the invert slope from 0.00421 ft/ft to 0.00517 ft/ft (Plate 17).

18. The ranges of gate openings (flood control) and discharges measured for combinations of flood-control and turbine releases for which slug flow occurred are shown in Plates 18-23. For comparison, presented with these data are the ranges of slug flow determined with the original length conduit. The discharge range for which slug flows occurred was shifted to higher discharges by shortening and steepening the conduit.

19. In an effort to reduce or eliminate slug flow conditions, the shortened conduit was vented (Plate 24). The ranges of slug flow were significantly reduced for all combinations of flood-control and turbine releases tested (Plates 25-30). Photo 8 shows flow conditions in the vicinity of the escape vent with the conduit experiencing slug flow farther downstream. The escape vent should be the same diameter as the conduit at their intersection, and the connection of the air vent to the conduit should cover the full width of the conduit. Tests to determine a minimum size escape vent indicated that the 14-ft-diam vent could be narrowed to a 5-ft-diam vent at a higher elevation without influencing its effectiveness in reducing the ranges of slug flow.

PART IV: CONCLUSIONS AND RECOMMENDATIONS

20. The results of the model investigation indicated the desirability of modifying certain elements of the outlet works for Dutch Gulch Dam as originally designed to provide adequate energy dissipation in the stilling basin, to reduce the wide range of discharges for which slug flow occurred, and to provide for a pressure-free turbine exit chamber.

21. Pressures were positive throughout the intake structure and conduit for all discharges observed.

22. The original design conduit (1,424 ft long, 14 ft in diameter) experienced slug flow over a wide range of controlled flow, which created excessive surges in the stilling basin and exit channel. The conduit length was reduced by 268.19 ft and the invert slope steepened from 0.00421 ft/ft to 0.00517 ft/ft due to design changes of the dam embankment slopes. This change shifted the discharge range in which slug flow occurred to higher discharges. By venting the shortened conduit, the range of flood-control discharges for which slug flow occurred was significantly reduced. Procedures should be adopted to limit the operation of flood-control discharges to avoid those ranges that cause slug flow; for example, see ranges presented in Plates 25-30. Slug flow could be eliminated by using a larger conduit to maintain partial flow conditions for all discharges.

23. Pressure flow occurred in the turbine exit chamber for turbine releases greater than 600 cfs. By enlarging the exit chamber portal and streamlining the portal invert, it is possible that greater turbine discharges could be released under partial flow conditions.

24. The original design stilling basin was modified by removing the one-half-sized baffle piers located against the basin sidewalls and interchanging the two rows of baffle piers in accordance with recommendations in EM 1110-2-1602.* The original design exit channel was found to be inadequate and yielded significantly higher tailwaters than expected. The exit channel was modified as discussed in paragraph 15 and shown in Plate 13. The type 2 design exit channel provided adequate depths of tailwater for good energy dissipation in the stilling basin.

* Office, Chief of Engineers, US Army, op. cit.

Table 1

Average Pressures in Flood-Control Conduit, Type 1 (Original) Design
Discharge 10,000 cfs, Pool El 725.0, Dual Gate Operation

<u>Piezometer</u>		<u>Pressure ft of water</u>	<u>Piezometer</u>		<u>Pressure ft of water</u>
<u>No.</u>	<u>El</u>		<u>No.</u>	<u>El</u>	
9	532.50	139.4	24	538.99	158.7
10	532.50	137.4	29	518.5	111.5
11	532.50	135.8	30	518.5	122.0
12	532.50	136.3	31	518.5	104.3
13	532.50	136.5	32	517.95	80.5
14	532.67	130.5	33	517.43	70.9
15	533.20	136.0	34	516.90	61.8
16	534.17	130.3	35	516.37	54.4
17	535.79	142.9	36	515.85	46.5
18	538.99	158.7	37	515.32	39.3
19	532.50	140.5	38	514.80	33.4
20	532.67	135.7	39	514.27	23.3
21	533.20	137.0	40	513.74	15.0
22	534.17	140.0	41	497.33	127.5
23	535.79	144.5	42	507.92	116.9

Table 2

Average Pressures in Flood-Control Conduit, Type 1 (Original) Design
Discharge 7,900 cfs, Pool El 725.0, Single Gate Operation

<u>Piezometer</u>		<u>Pressure ft of water</u>	<u>Piezometer</u>		<u>Pressure ft of water</u>
<u>No.</u>	<u>El</u>		<u>No.</u>	<u>El</u>	
9	532.50	64.5	31	518.50	25.5
10	532.50	60.5	32	517.95	69.1
11	532.50	57.0	33	517.43	61.6
12	532.50	56.5	34	516.90	53.1
13	532.50	57.0	35	516.37	47.6
14	532.67	43.3	36	515.85	41.2
15	533.20	58.2	37	515.32	35.7
16	534.17	45.8	38	514.80	31.2
17	535.79	78.6	39	514.27	26.2
18	538.99	124.0	40	513.74	21.1
29	518.50	3.5	41	497.33	27.7
30	518.50	5.5	42	507.92	17.1

Table 3

Average Pressures in Water Quality Bypass Conduits, Type 1 (Original)
Design, Pool El 745, Design Discharge 1,200 cfs

<u>General Location</u>	<u>Piezometer</u>		<u>Pressure ft of water</u>
	<u>No.</u>	<u>El</u>	
3.25- by 3.25-ft conduit, discharge 750 cfs	1	540.69	94.0
	2	536.86	97.6
	3	534.37	97.6
	4	532.50	89.5
3.0- by 3.0-ft conduit, discharge 450 cfs	5	540.44	149.6
	6	536.61	141.4
	7	534.12	139.4
	8	532.50	141.5
Left wet well	25	533.00	210.0
	26	533.00	210.0
Right wet well	27	533.00	210.2
	28	533.00	210.2

Table 4

Average Pressures in Turbine Exit Chamber, Type 1 (Original) Design

<u>Pool El</u>	<u>Turbine Discharge cfs</u>	<u>Flood- Control Discharge cfs</u>	<u>Average Pressure ft of water</u>		<u>Fluctuation About the Average ft of water</u>
			<u>Floor</u>	<u>Roof</u>	
745	1,170	--	37.5	5.5	±0.9
	650	--	30.7	0.5	±0.5
	600	--	30.2	--	±0.5
	550	--	29.9	--	±0.3
725	500	9,800	151.7	121.5	±2.5
	--	10,000	127.5	97.3	±2.0
	--	7,900	27.7	--	±0.5

Table 5
Water-Surface Elevations in Stilling Basin

<u>Sta</u>	<u>Water-Surface El</u>		
	<u>Left Side</u>	<u>Center Line</u>	<u>Right Side</u>
<u>1,000-cfs Discharge</u>			
37+08.54	520.5	520.4	520.5
37+25.00	520.4	520.5	520.4
37+50.00	517.4	517.4	517.4
37+75.00	513.8	514.2	514.0
37+95.00	510.3	510.4	510.4
38+00.00	510.9	510.7	510.8
38+25.00	512.5	512.7	512.5
38+50.00	513.0	512.9	513.0
39+00.00	512.9	512.8	512.8
39+76.89	512.7	512.7	512.7
<u>5,000-cfs Discharge</u>			
37+08.54	521.7	521.4	522.1
37+25.00	521.7	521.9	521.5
37+50.00	519.5	521.0	519.7
37+15.00	516.4	516.4	516.7
38+00.00	511.6	511.2	511.5
38+07.00	511.9	512.5	511.5
38+25.00	514.7	514.6	514.5
38+50.00	515.6	515.8	515.8
39+00.00	518.5	518.5	518.6
39+50.00	519.9	518.7	518.8
39+76.89	518.7	518.5	518.8
<u>10,000-cfs Discharge</u>			
37+08.54	524.6	526.9	524.3
37+25.00	524.4	527.0	523.8
37+50.00	522.7	524.2	522.7
37+75.00	519.5	519.8	519.5
38+00.00	513.5	513.8	513.6
38+25.00	511.5	511.5	511.5
38+50.00	513.7	514.5	514.5
38+75.00	514.5	514.0	514.5
39+00.00	517.0	517.0	517.0
39+25.00	519.8	519.5	519.8
39+50.00	523.1	523.3	523.1
39+76.89	523.1	522.4	523.1

Note: Sides of basin are referenced to downstream direction.
Stations given are for the original design conduit.

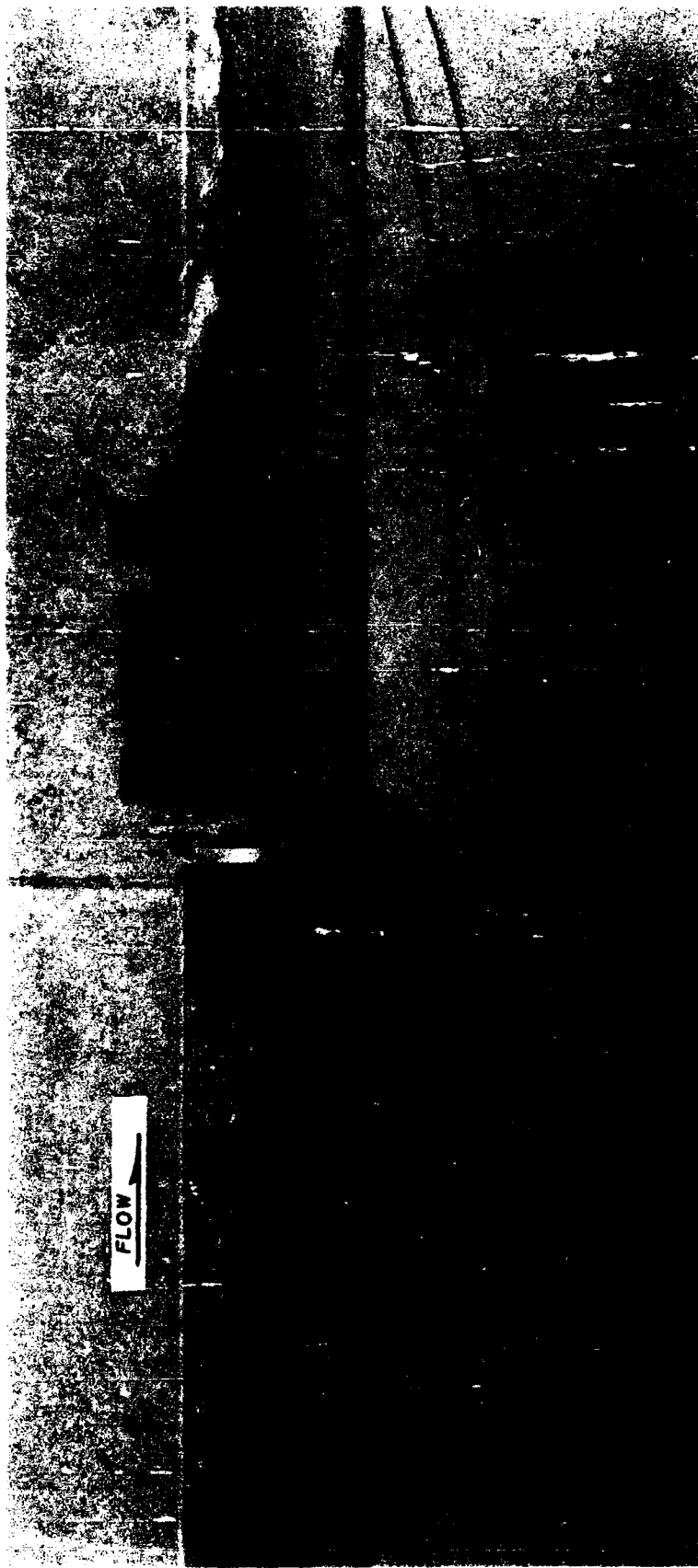
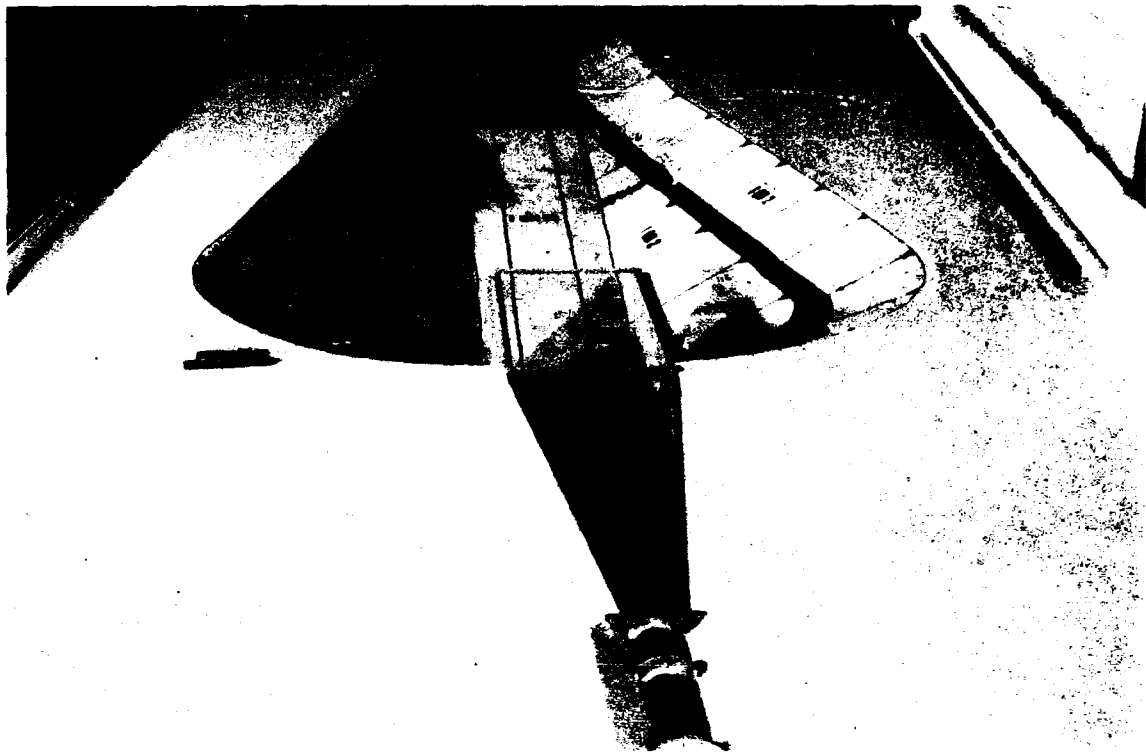


Photo 1. Slug flow in original design conduit with 8,000-cfs discharge and pool el 740



a. Dry bed



b. Slug flow, discharge
8,000 cfs

Photo 2. Stilling basin and exit channel, original design

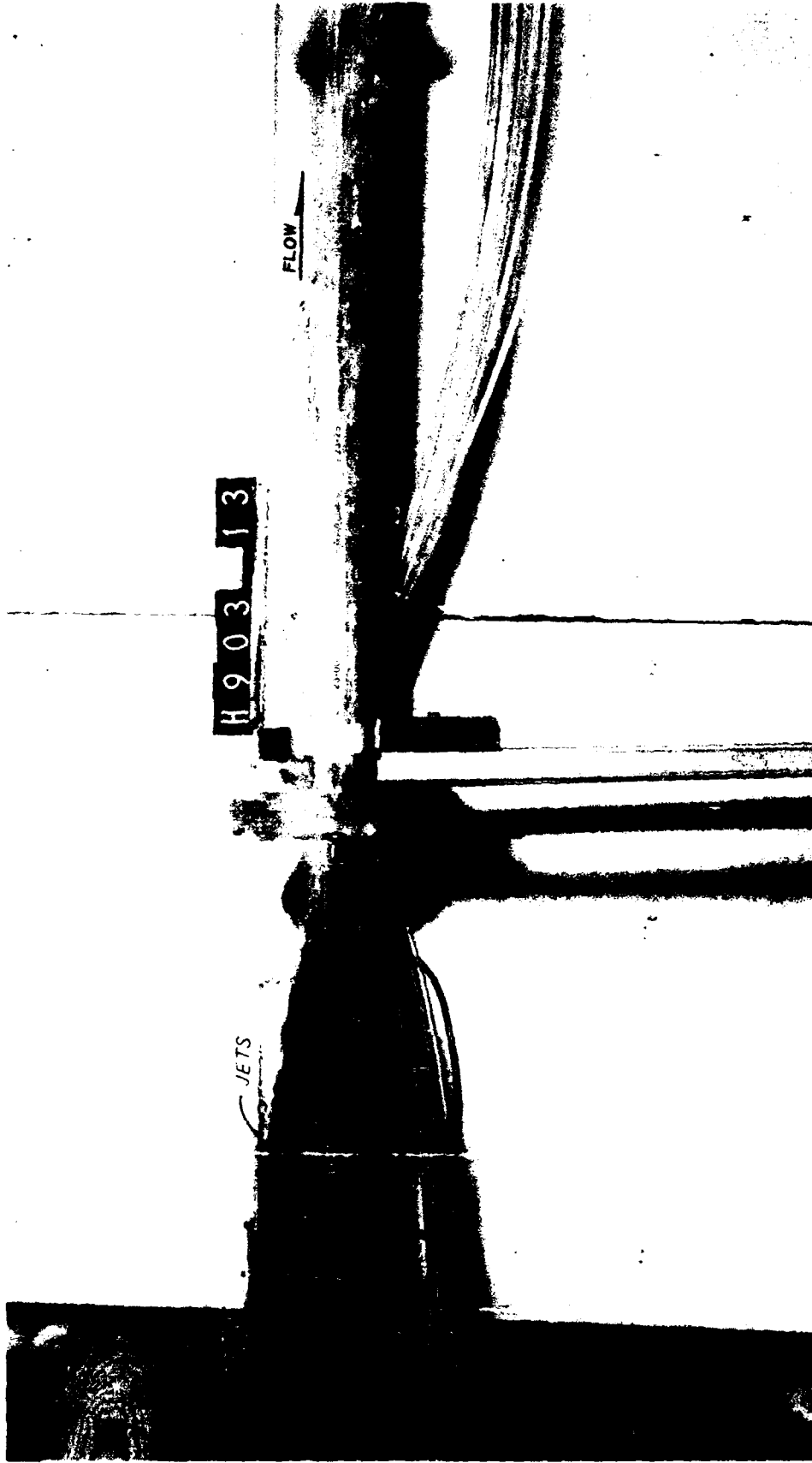
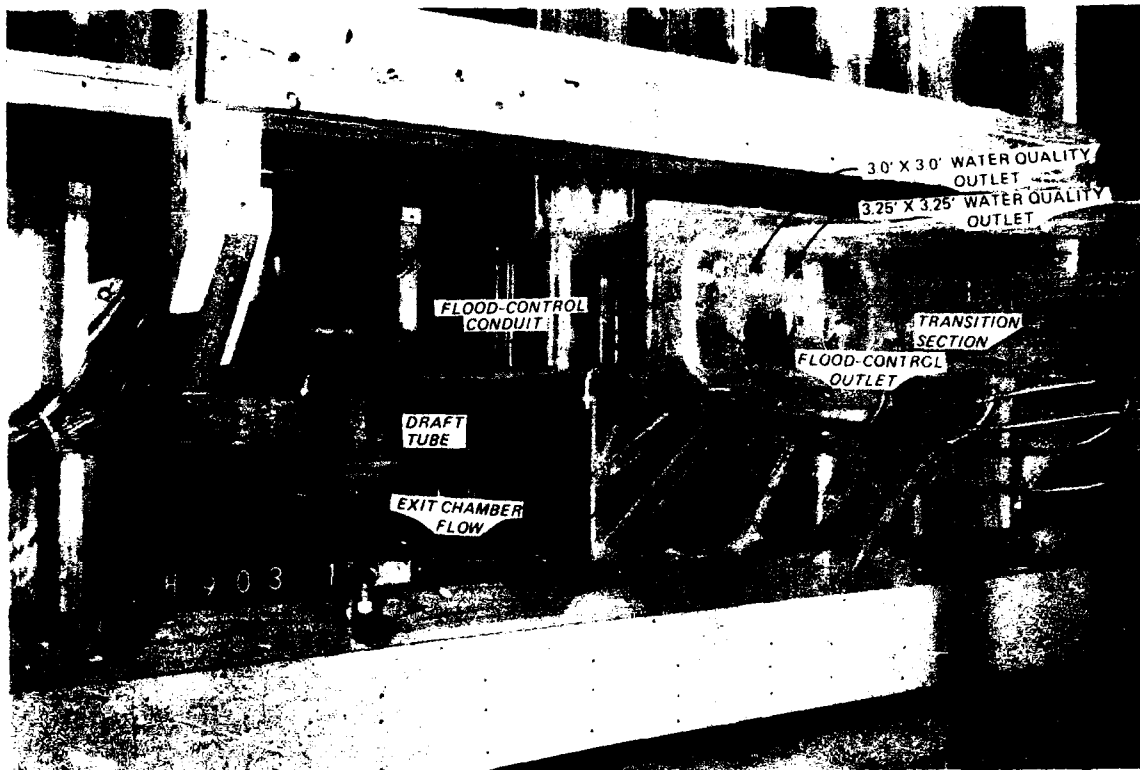
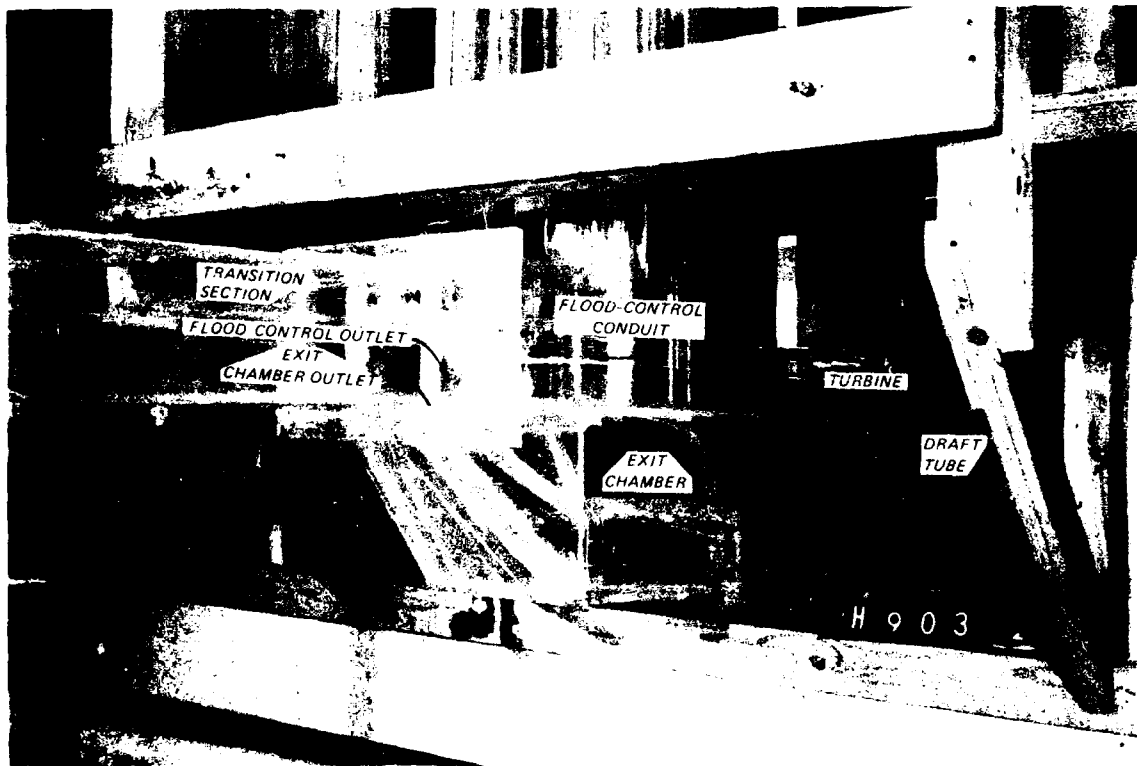


Photo 3. Design water quality discharge of 1,200 cfs, 3.0- by 3.0-ft conduit with a discharge of 450 cfs, 3.25- by 3.25-ft conduit with a discharge of 750 cfs, pool el 725.0



a. Right side looking upstream

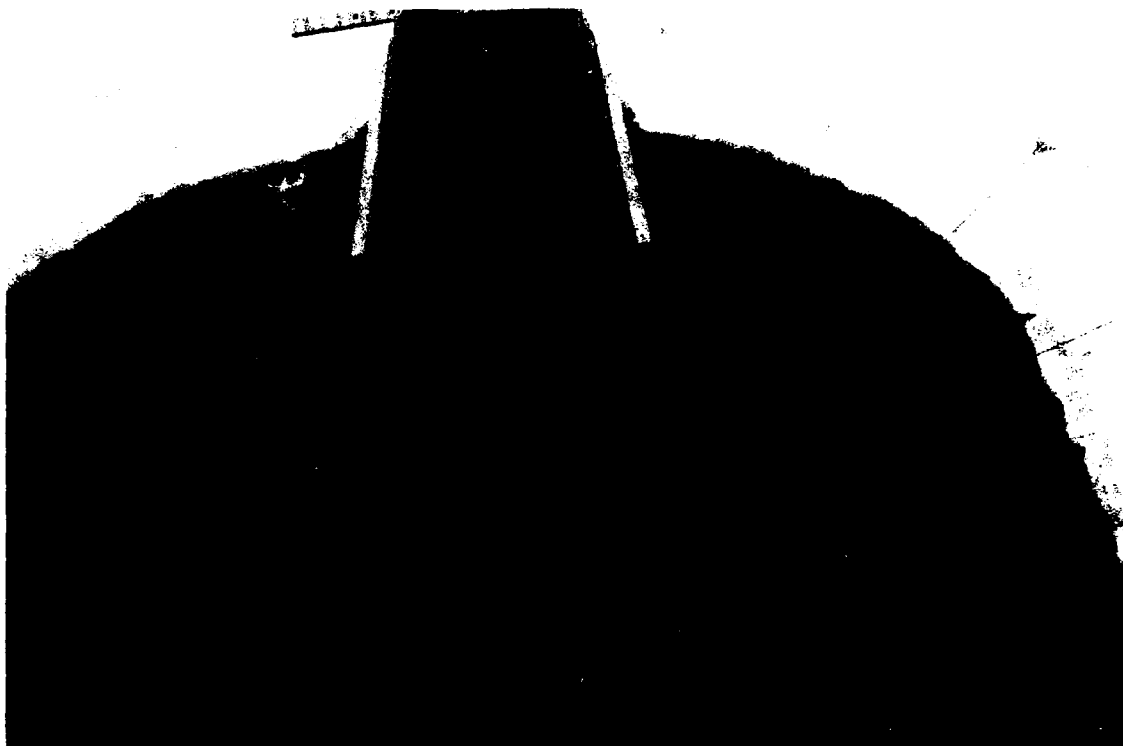


b. Left side looking upstream

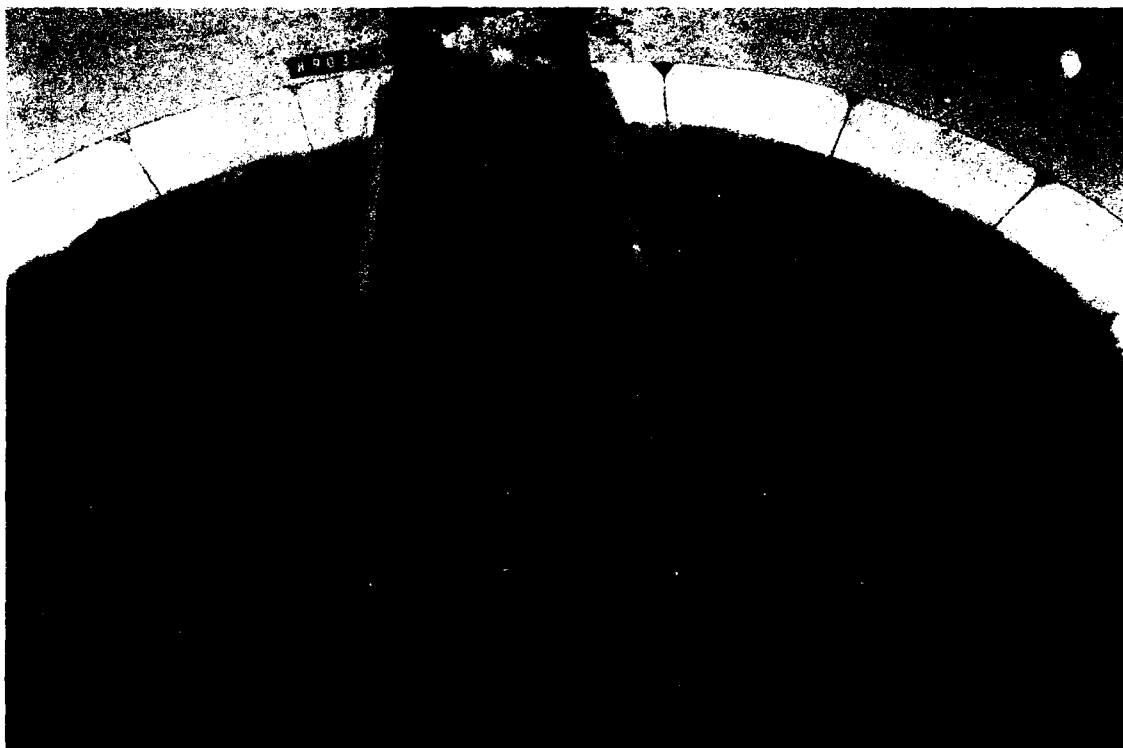
Photo 4. Flow passages into conduit transition section



Photo 5. Design turbine discharge of 1,170 cfs (unit 1, 120 cfs; unit 2, 300 cfs; unit 3, 750 cfs),
pool el 745

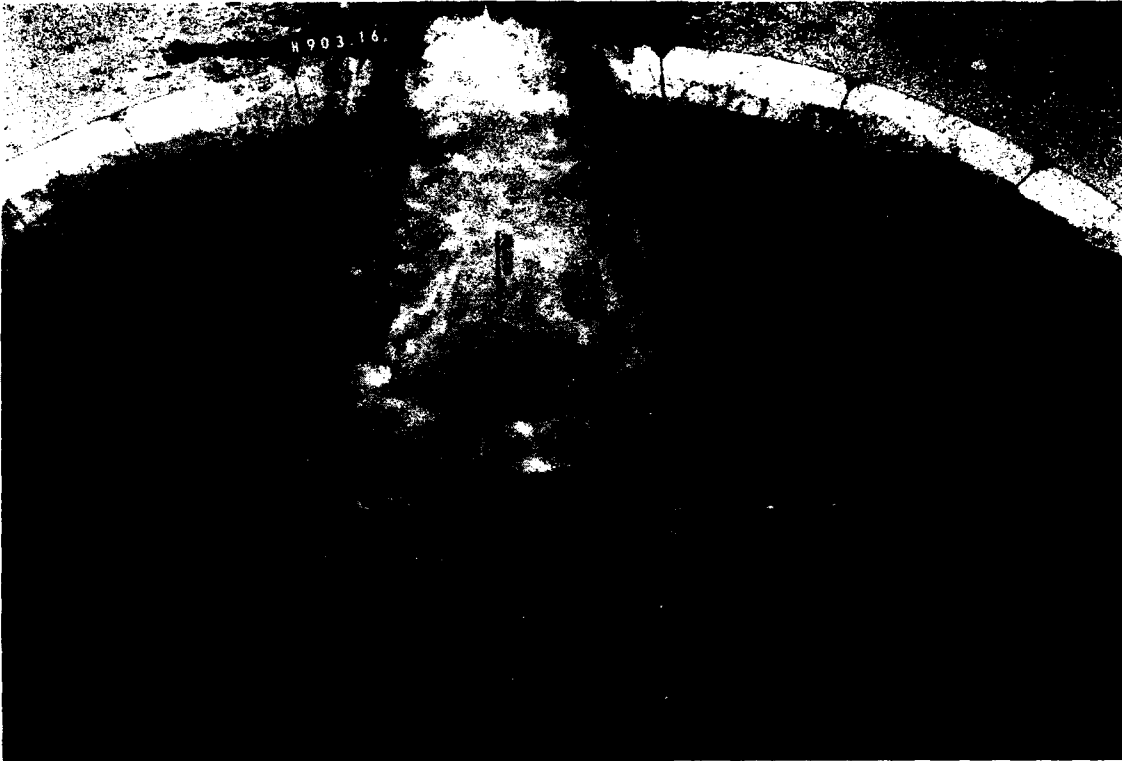


a. Discharge 1,000 cfs, tailwater el 512.7



b. Discharge 5,000 cfs, tailwater el 518.3

Photo 6. Flow conditions in stilling basin,
type 2 exit channel (Continued)



c. Discharge 10,000 cfs, tailwater el 522.2

Photo 6. (Concluded)



a. Tailwater el 517.0

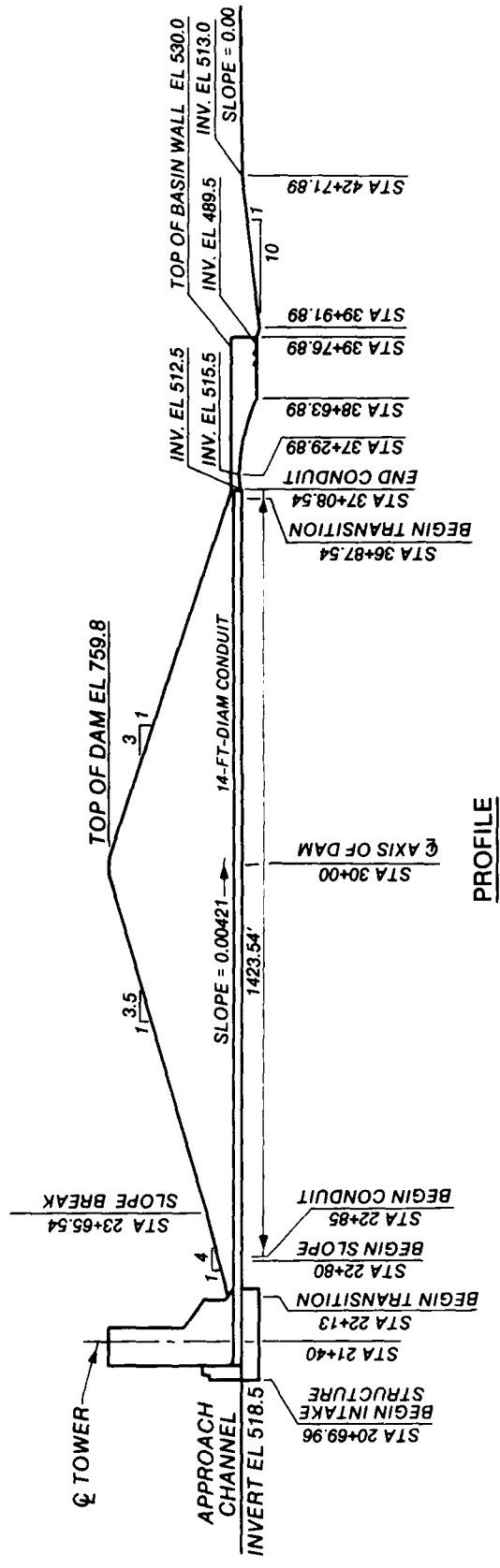
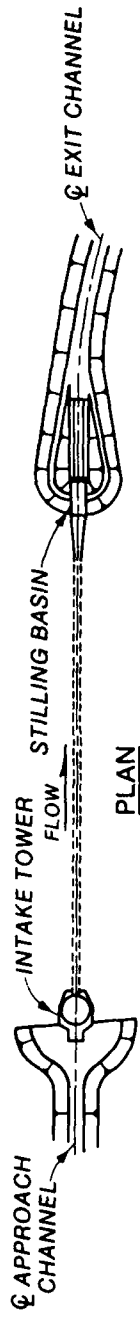


b. Tailwater el 527.0

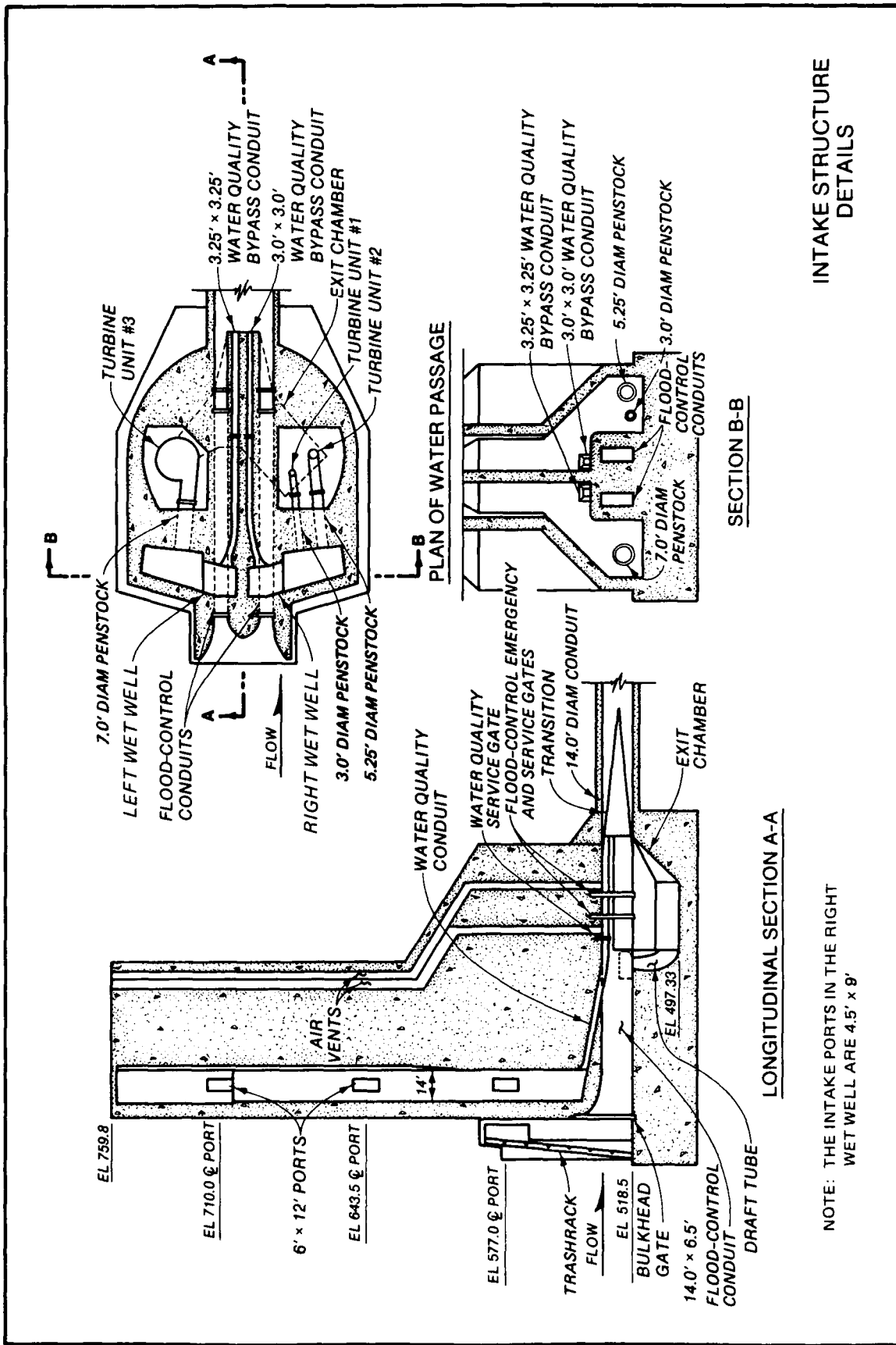
Photo 7. Flow conditions in stilling basin, type 2 exit channel,
discharge 10,000 cfs

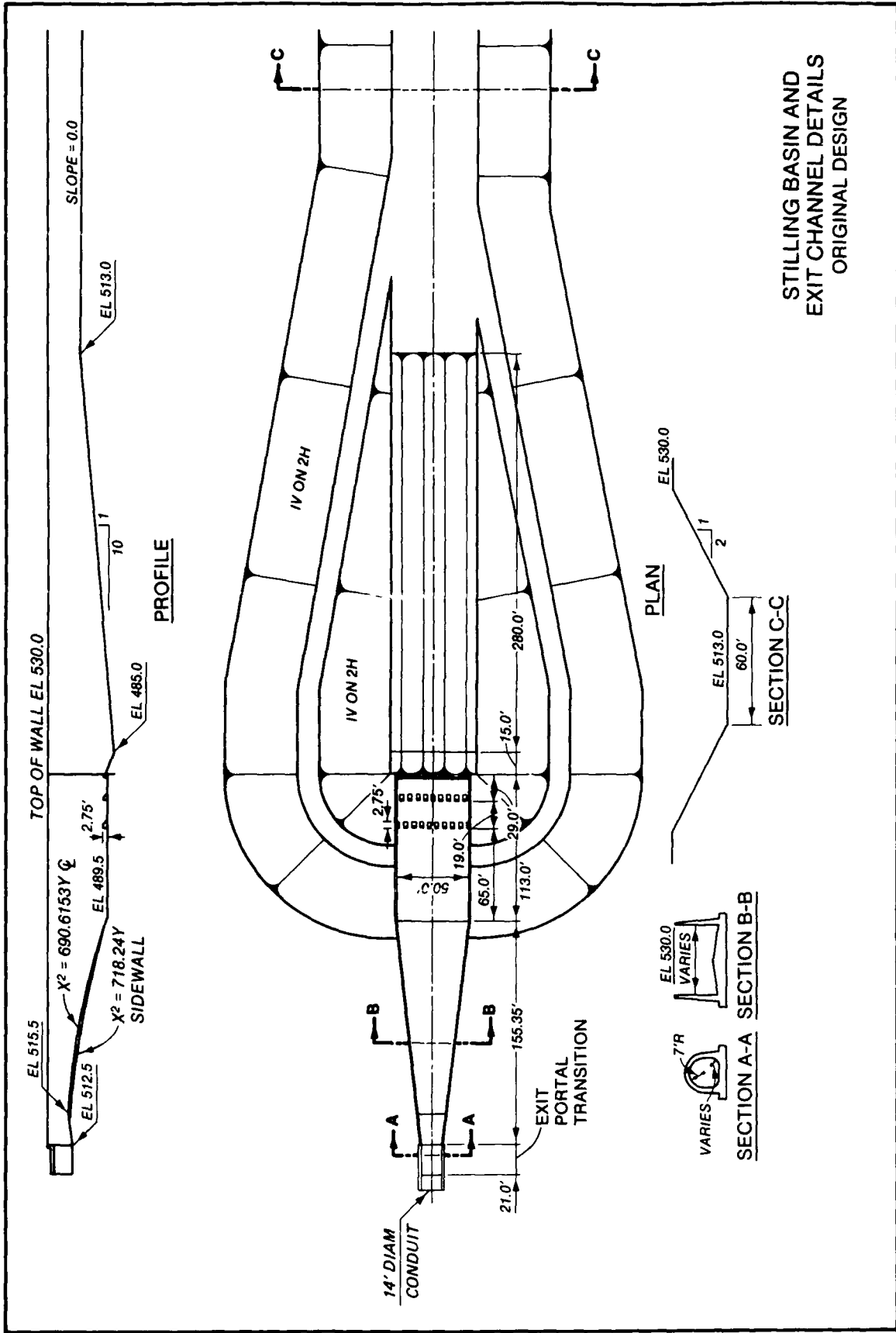


Photo 8. Flow conditions in the vicinity of the escape vent, discharge 8,250 cfs

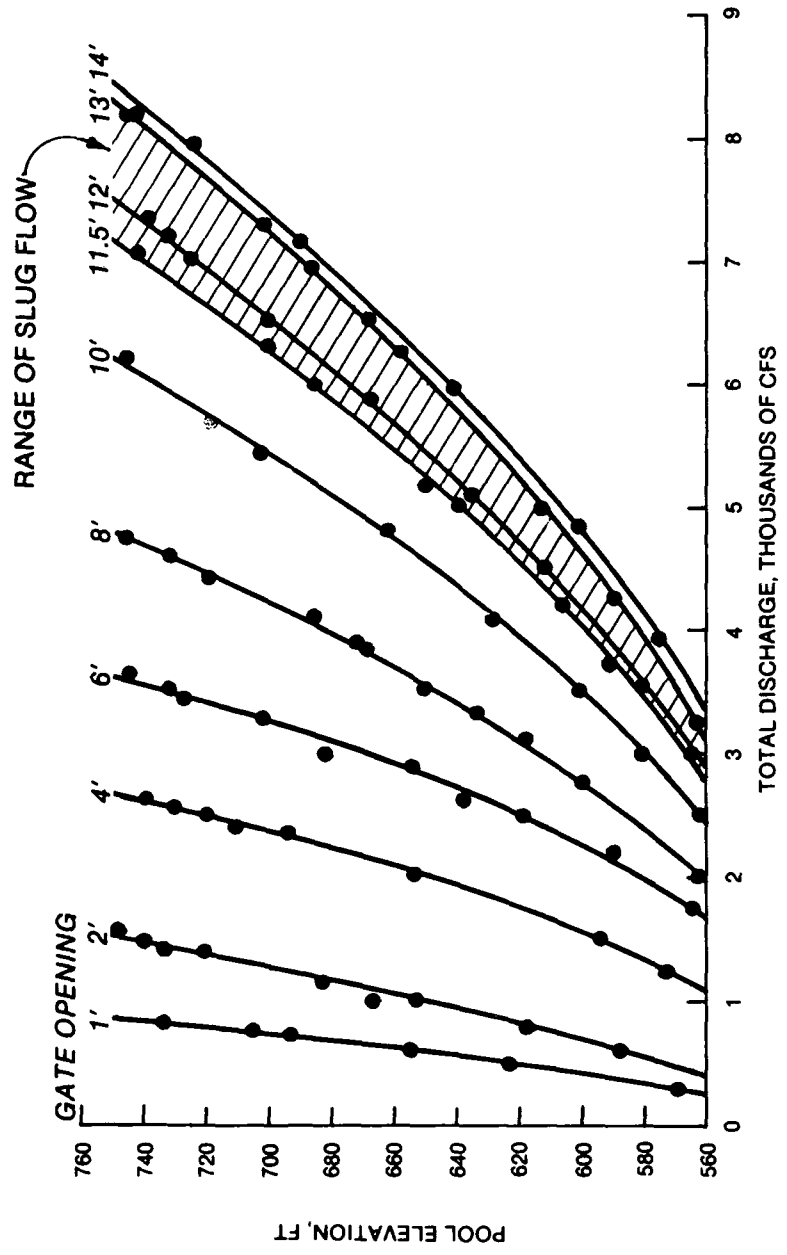


GENERAL PLAN AND PROFILE
ORIGINAL DESIGN



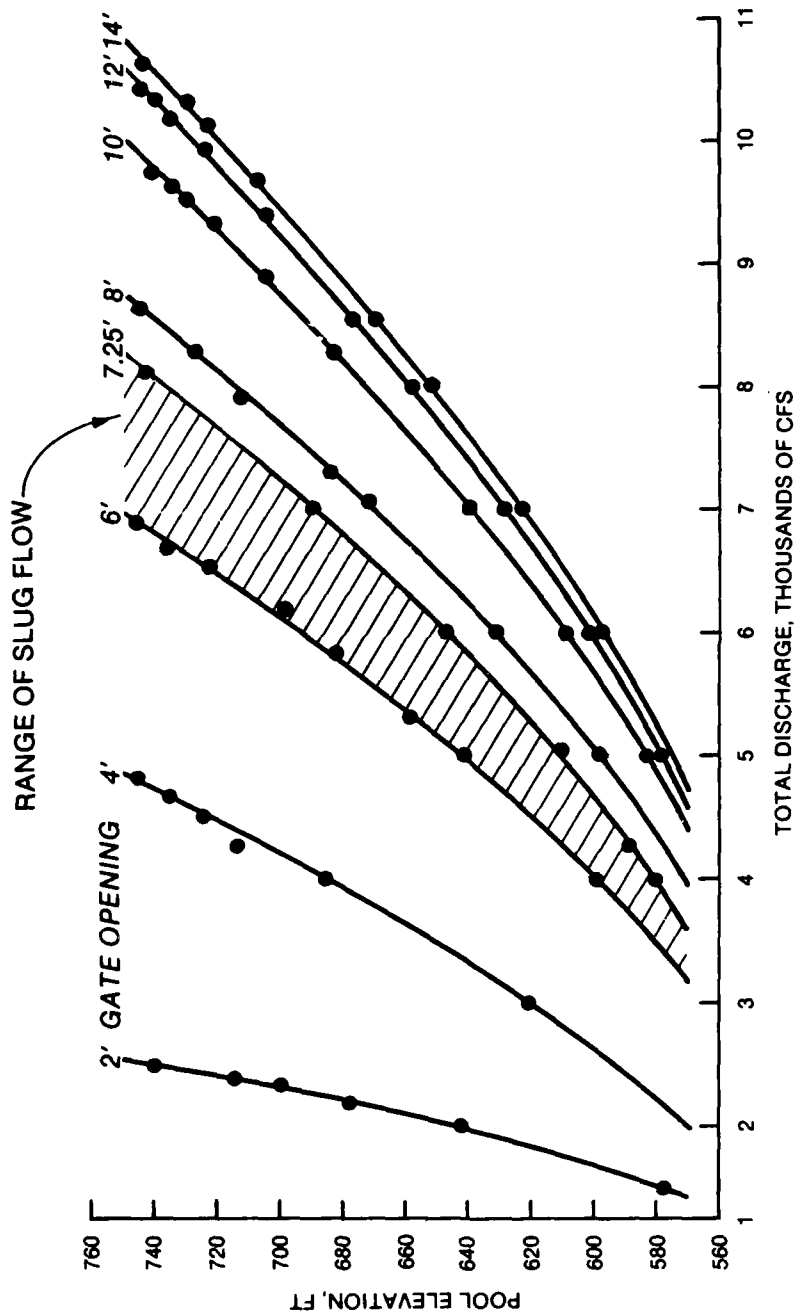


STILLING BASIN AND
EXIT CHANNEL DETAILS
ORIGINAL DESIGN

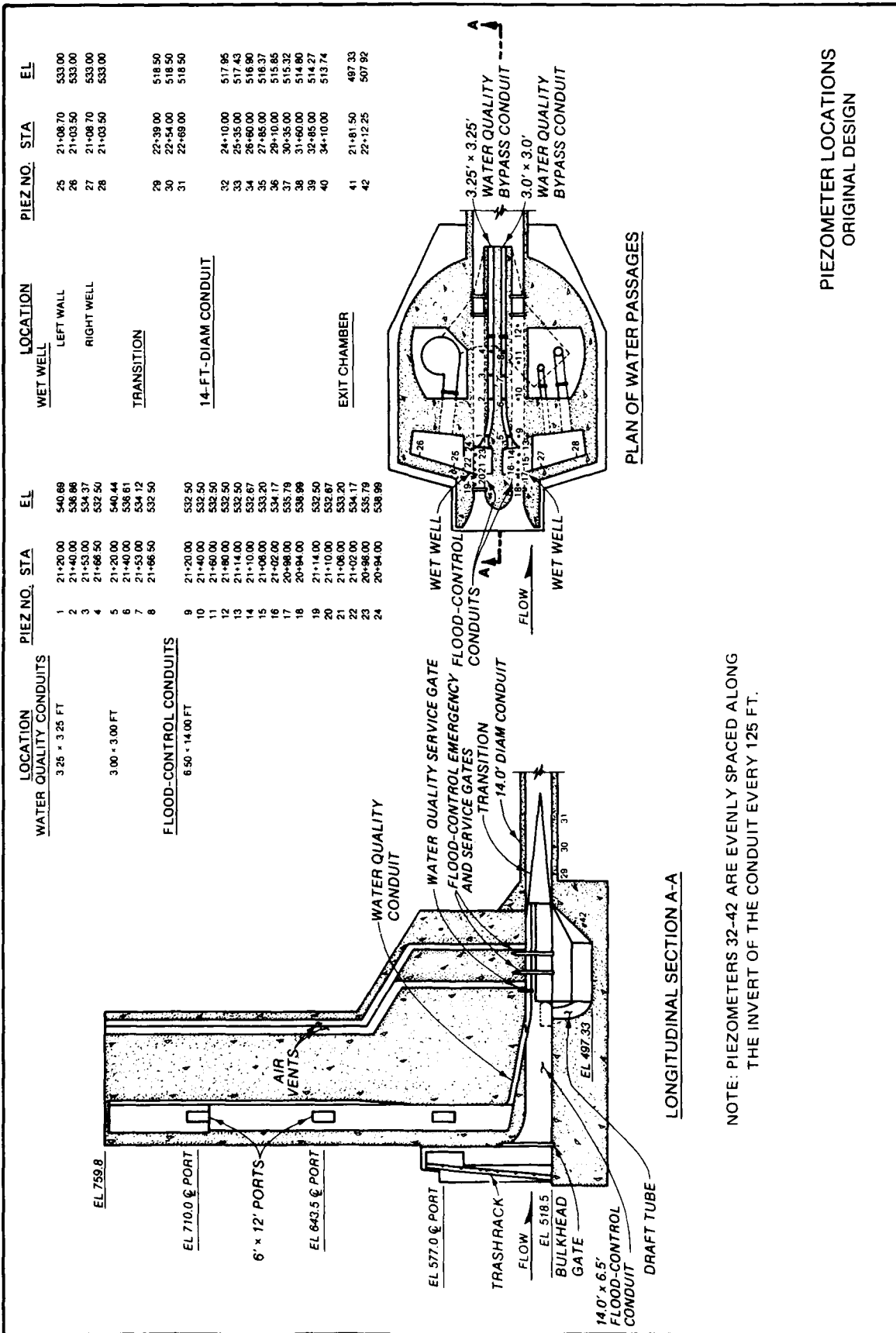


DISCHARGE RATING CURVES
 FLOOD-CONTROL FLOW
 SINGLE GATE OPERATION
 ORIGINAL CONDUIT

PLATE 4

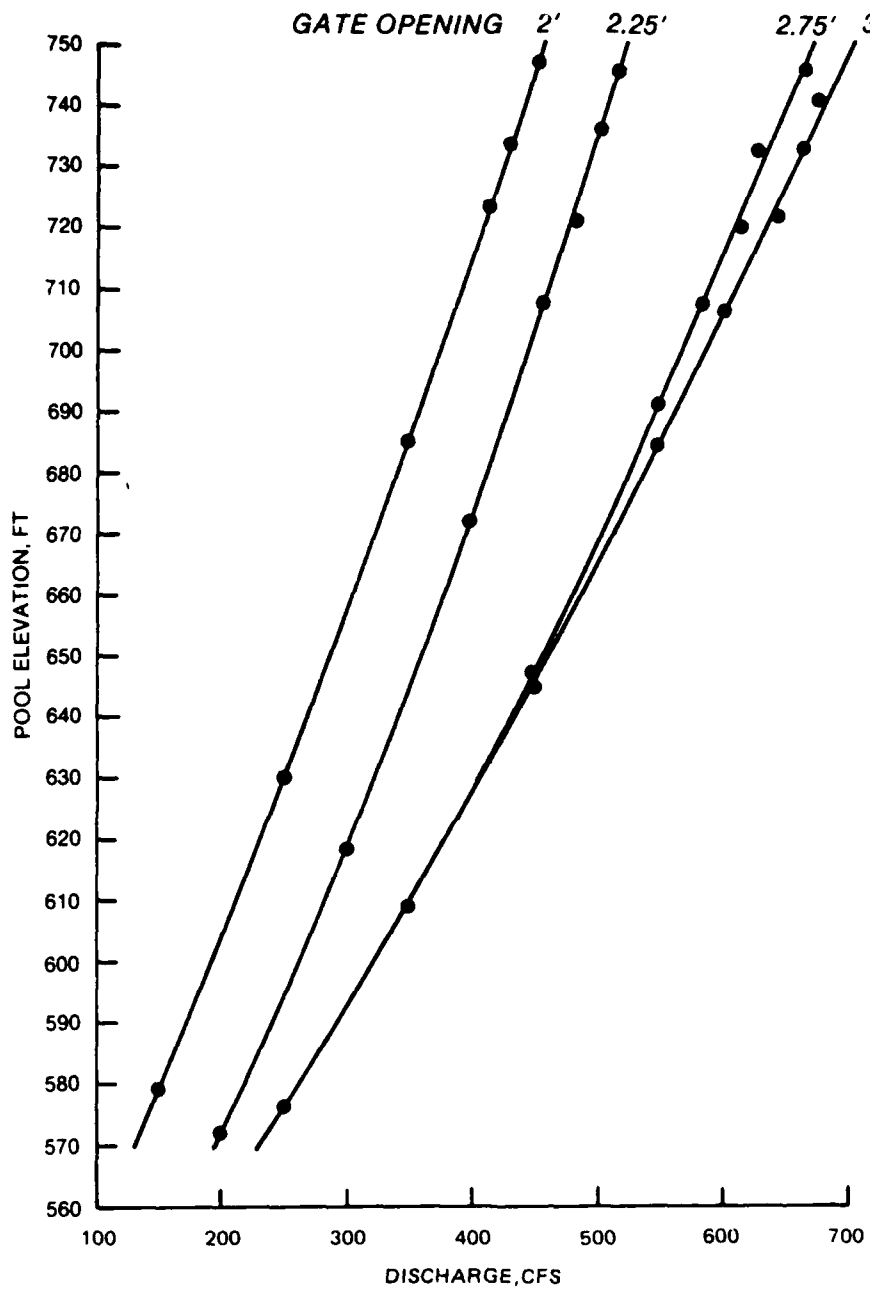


DISCHARGE RATING CURVES
 FLOOD-CONTROL FLOW
 DUAL GATE OPERATION
 ORIGINAL CONDUIT

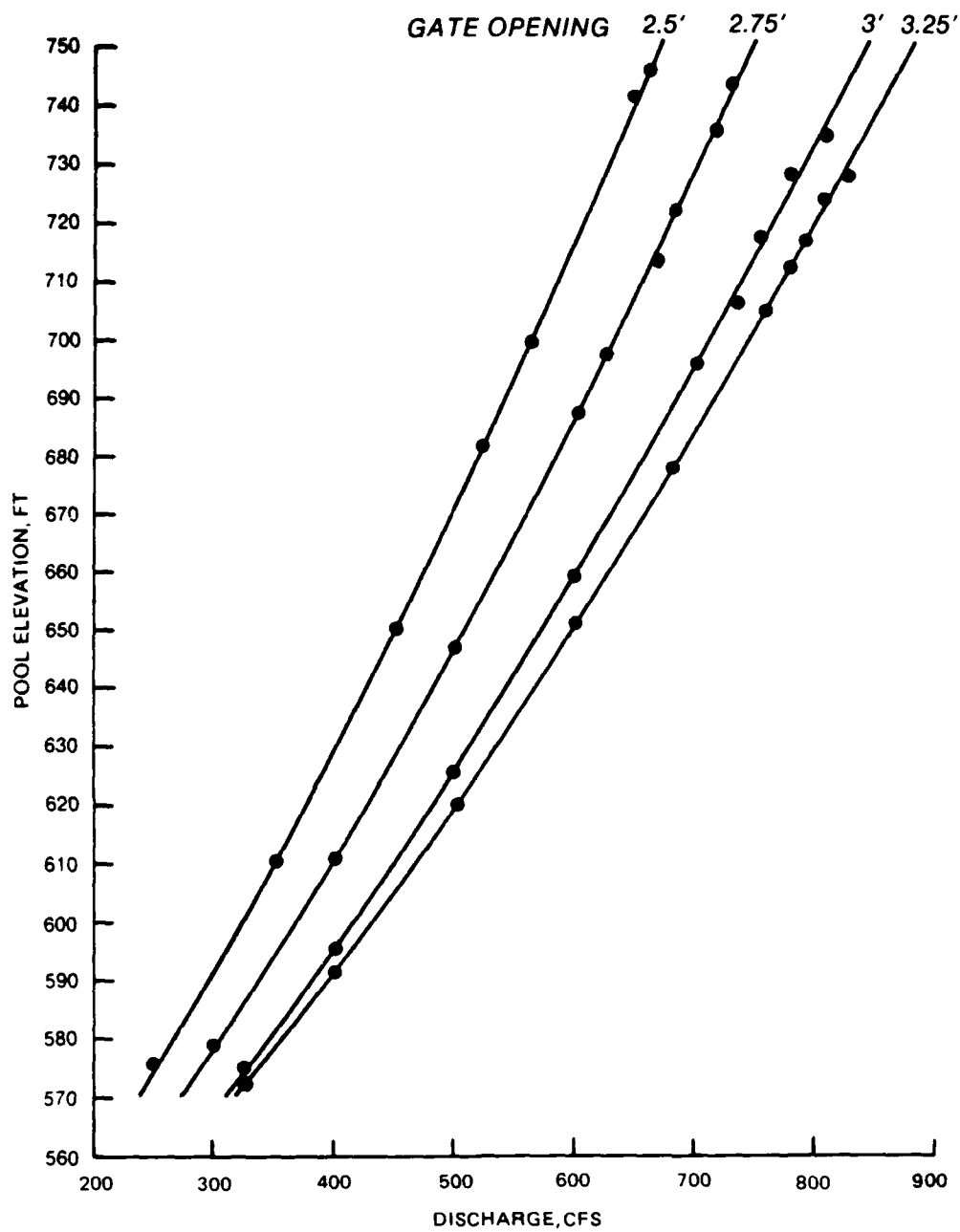


PIEZ. NO.	STA	EL	LOCATION	PIEZ. NO.	STA	EL
WATER QUALITY CONDUITS						
3.25' x 3.25' FT						
1	21+20.00	540.89	LEFT WALL	25	21+08.70	533.00
2	21+40.00	536.86		26	21+03.50	533.00
3	21+53.00	534.37		27	21+08.70	533.00
4	21+66.50	532.50		28	21+03.50	533.00
3.00' x 3.00' FT						
5	21+20.00	540.44	RIGHT WALL	29	22+39.00	518.50
6	21+40.00	536.61		30	22+54.00	518.50
7	21+53.00	534.12		31	22+69.00	518.50
8	21+66.50	532.50				
FLOOD-CONTROL CONDUITS						
6.50' x 14.00' FT						
9	21+20.00	532.50	14-FT-DIAM CONDUIT	32	24+10.00	517.95
10	21+40.00	532.50		33	25+35.00	517.43
11	21+60.00	532.50		34	26+60.00	516.90
12	21+80.00	532.50		35	27+85.00	516.37
13	21+14.00	532.87		36	29+10.00	515.85
14	21+10.00	532.87		37	30+35.00	515.32
15	21+08.00	533.20		38	31+60.00	514.79
16	21+02.00	534.17		39	32+85.00	514.27
17	20+98.00	533.79		40	34+10.00	513.74
18	20+94.00	536.96				
EXIT CHAMBER						
19	21+14.00	532.50		41	21+81.50	487.33
20	21+10.00	532.87		42	22+12.25	507.92
21	21+06.00	533.20				
22	21+02.00	534.17				
23	20+96.00	535.79				
24	20+94.00	538.99				

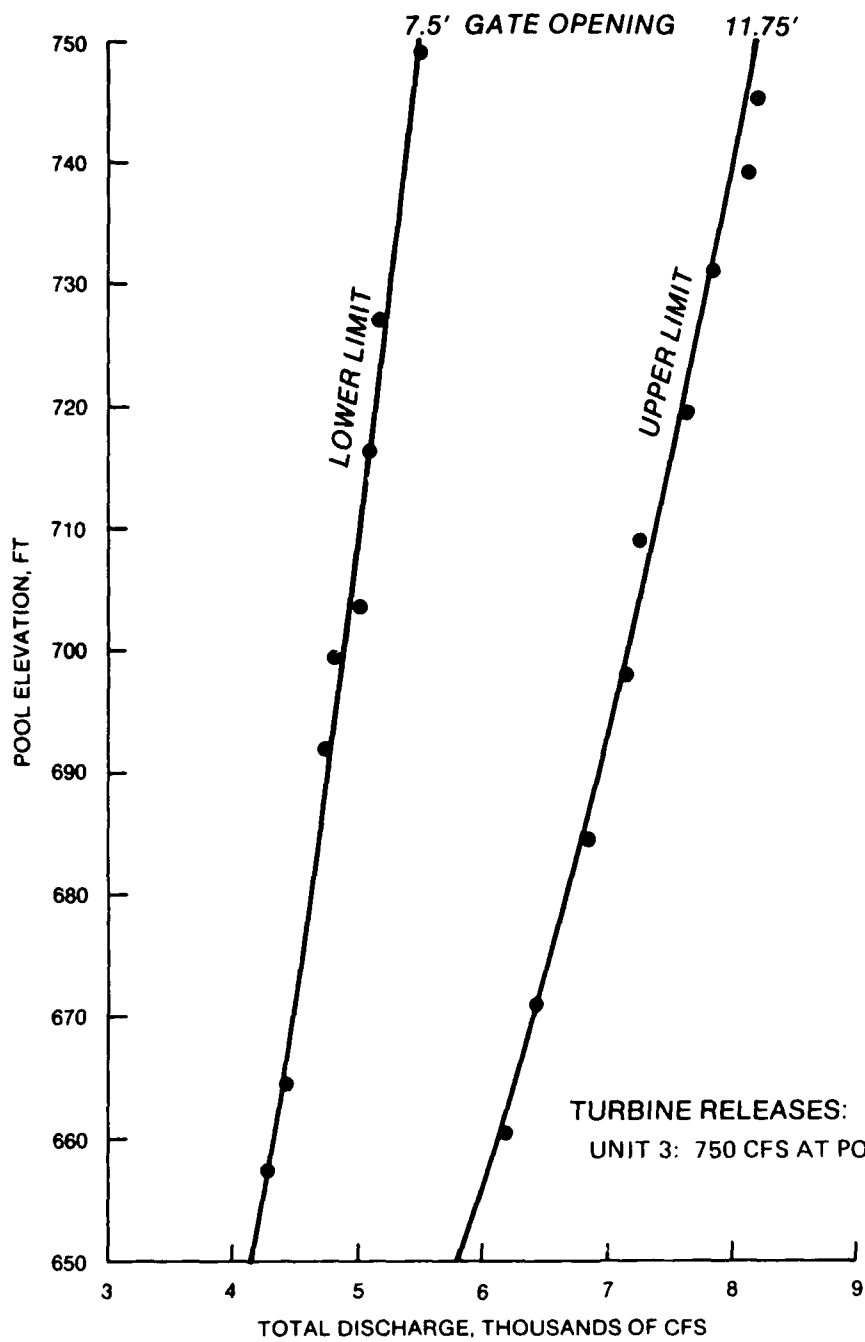
PIEZOMETER LOCATIONS
ORIGINAL DESIGN



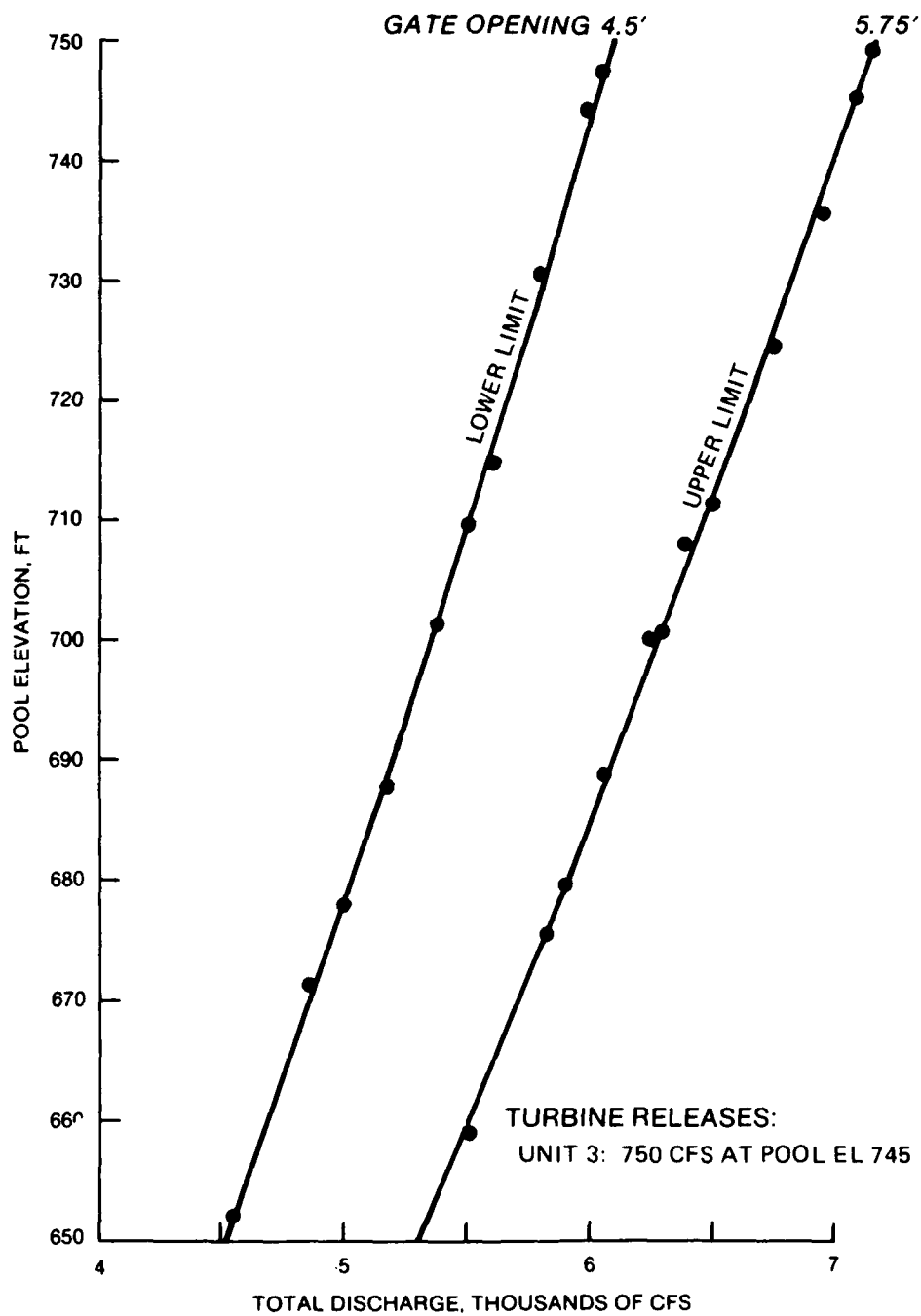
DISCHARGE RATING CURVES
 WATER QUALITY FLOW
 3.0- by 3.0-FT CONDUIT



DISCHARGE RATING CURVES
 WATER QUALITY FLOW
 3.25- by 3.25-FT CONDUIT

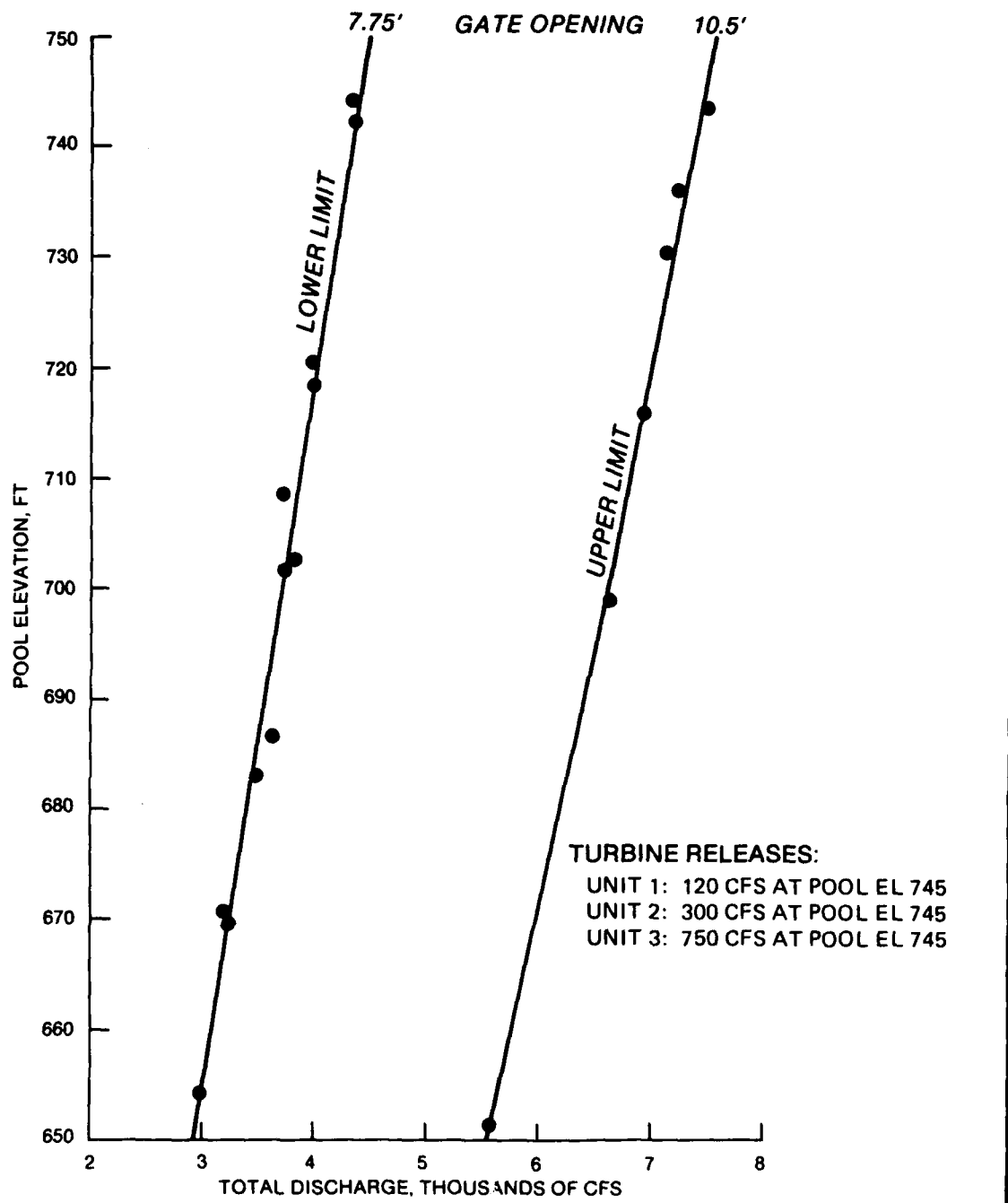


LIMITS OF SLUG FLOW
 COMBINED FLOOD-CONTROL AND
 TURBINE RELEASES
 FLOOD CONTROL WITH SINGLE GATE OPERATION
 ORIGINAL CONDUIT
 TURBINE UNIT 3

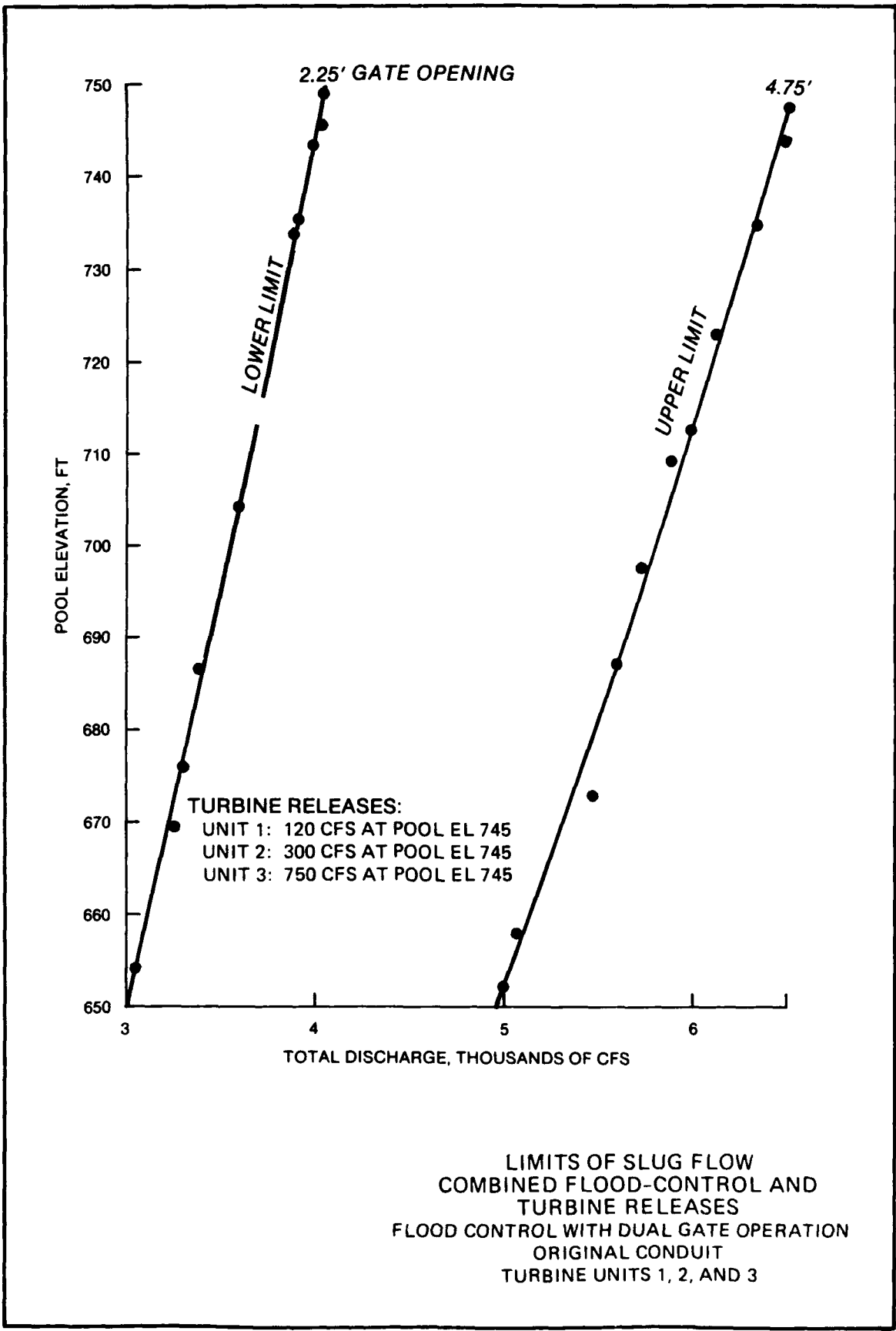


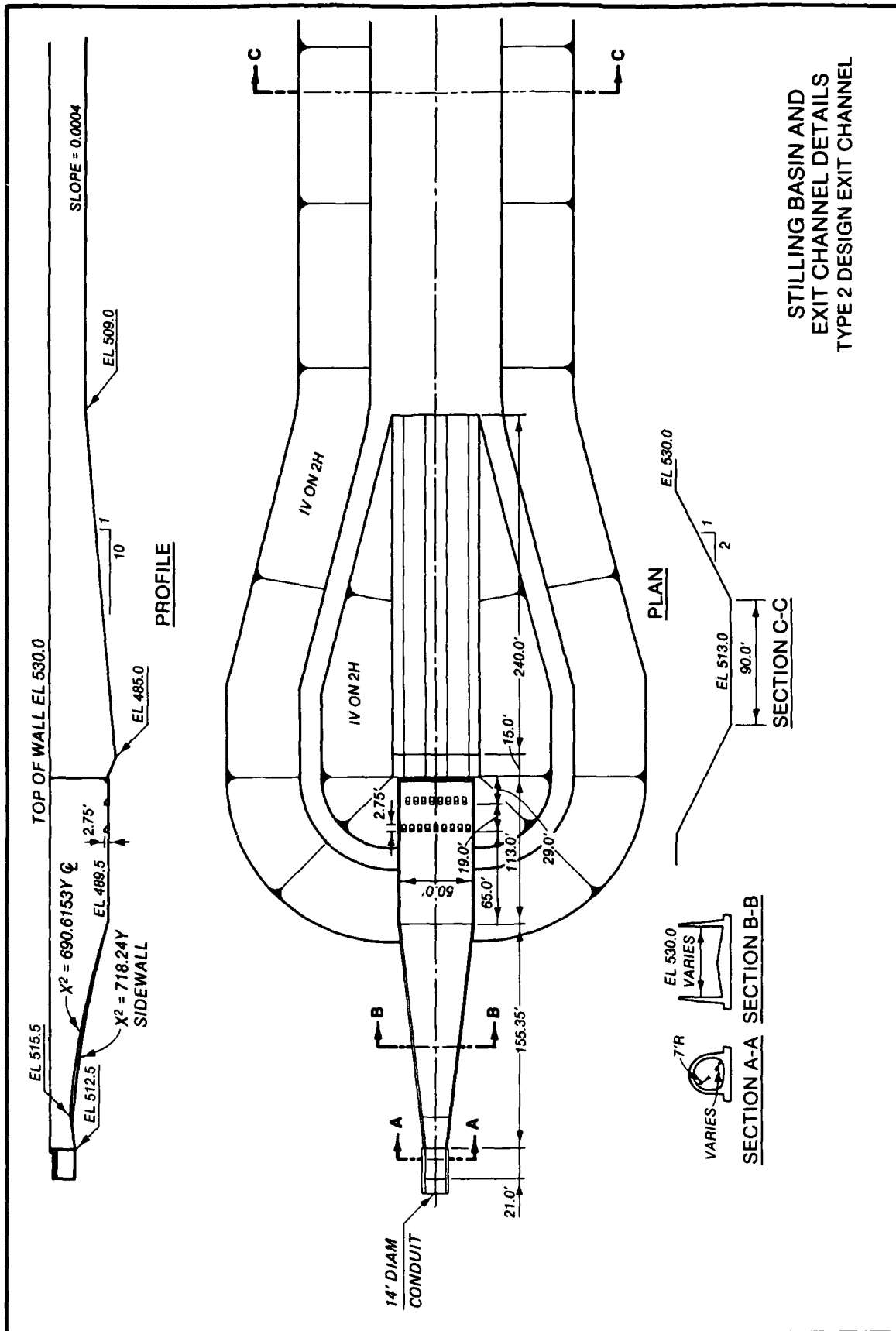
TURBINE RELEASES:
 UNIT 3: 750 CFS AT POOL EL 745

LIMITS OF SLUG FLOW
 COMBINED FLOOD-CONTROL AND
 TURBINE RELEASES
 FLOOD CONTROL WITH DUAL GATE OPERATION
 ORIGINAL CONDUIT
 TURBINE UNIT 3



LIMITS OF SLUG FLOW
 COMBINED FLOOD-CONTROL AND
 TURBINE RELEASES
 FLOOD CONTROL WITH SINGLE GATE OPERATION
 ORIGINAL CONDUIT
 TURBINE UNITS 1, 2, AND 3





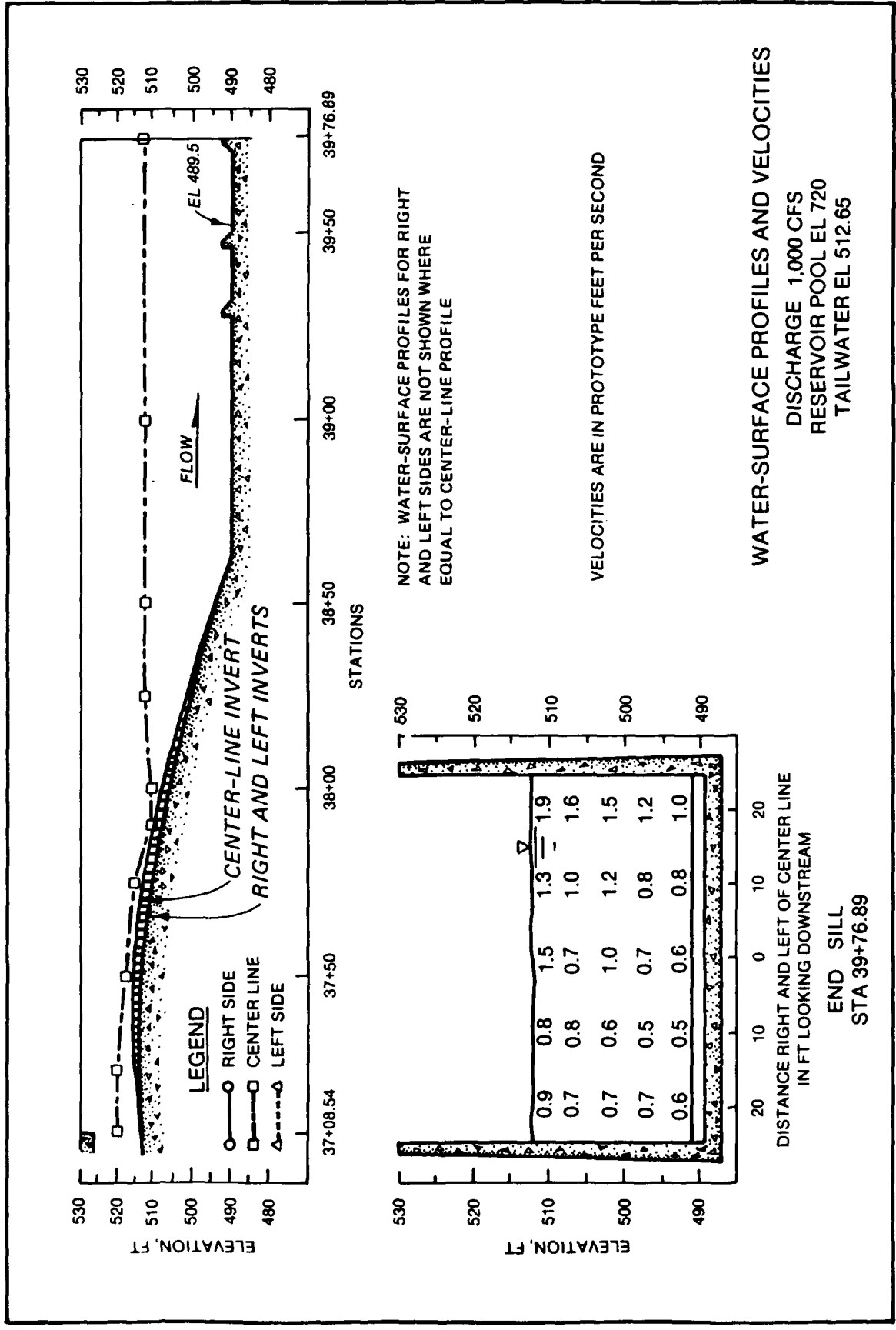
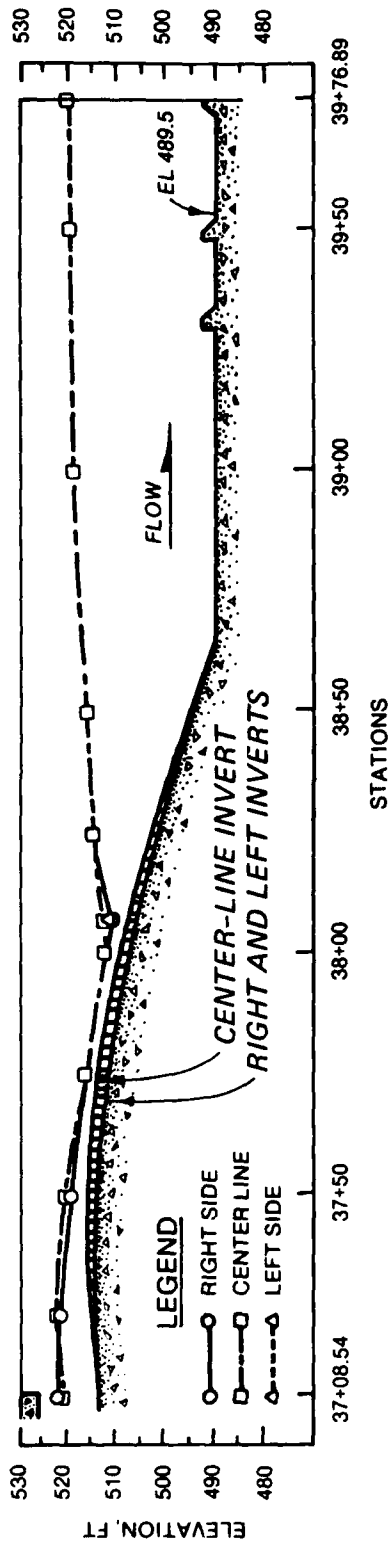
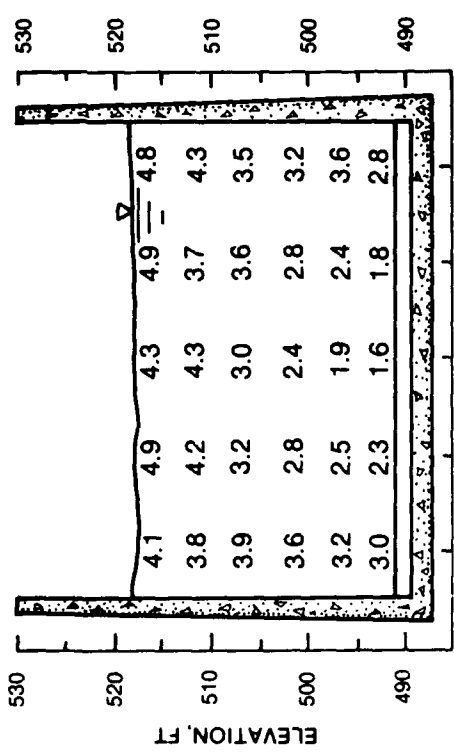


PLATE 14



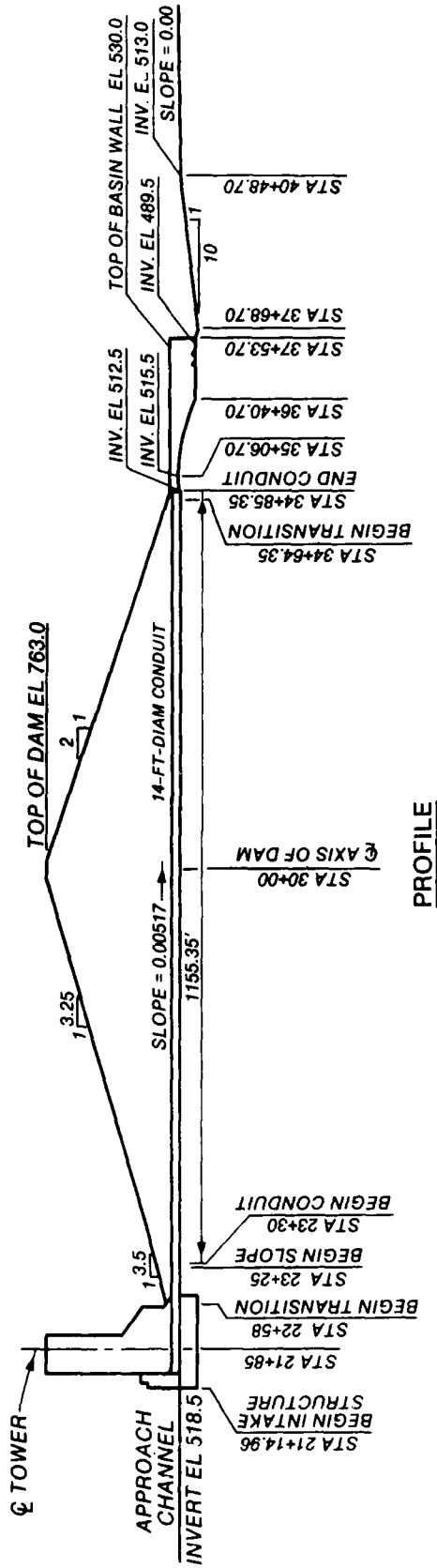
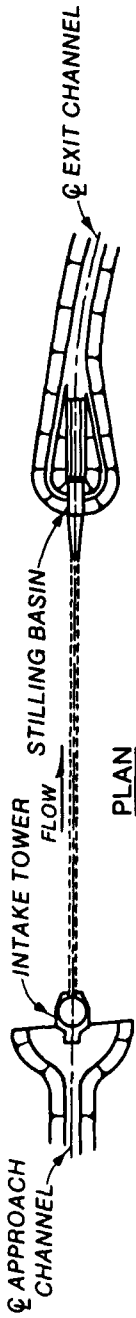
NOTE: WATER-SURFACE PROFILES FOR RIGHT AND LEFT SIDES ARE NOT SHOWN WHERE EQUAL TO CENTER-LINE PROFILE

VELOCITIES ARE IN PROTOTYPE FEET PER SECOND

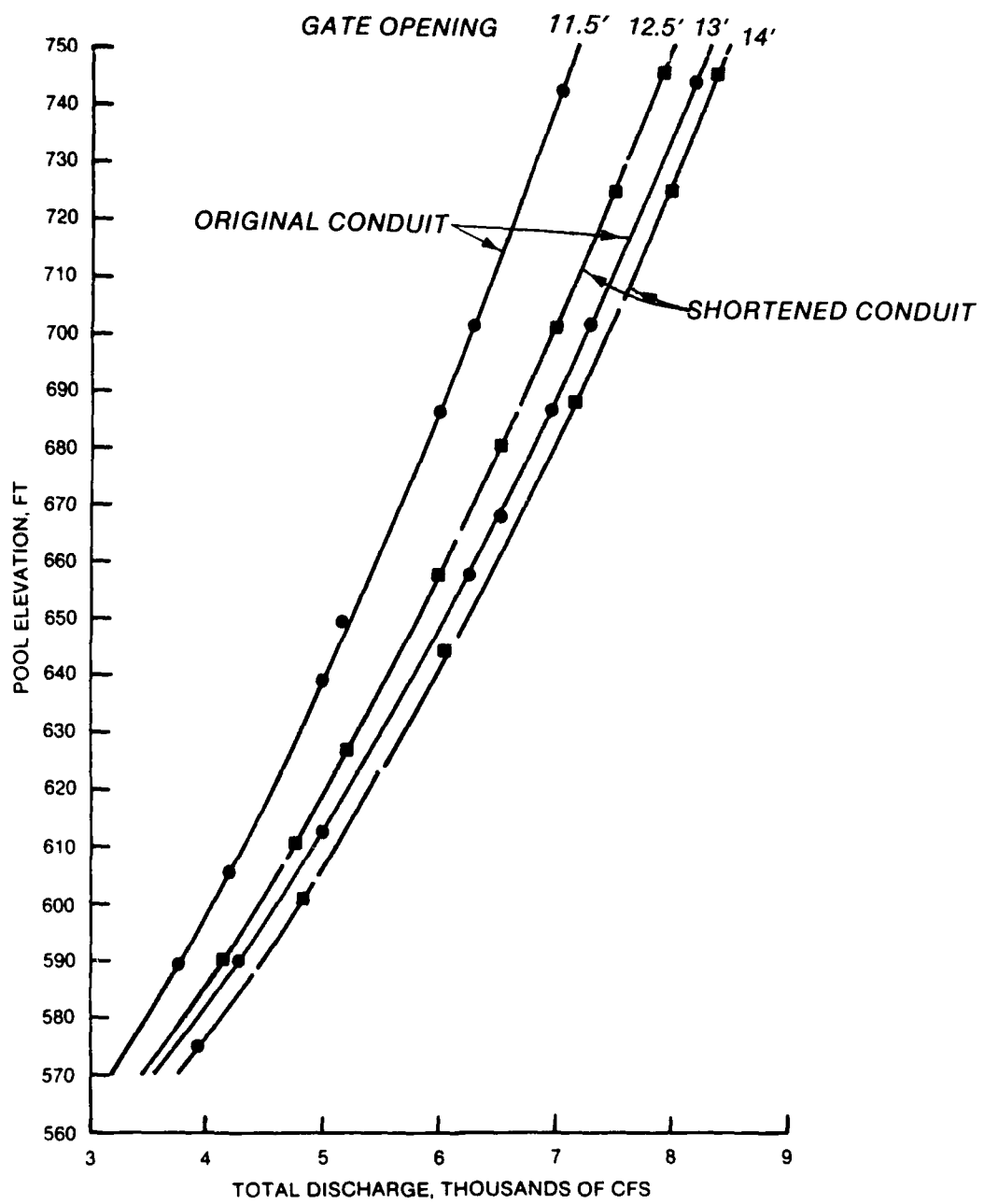


WATER-SURFACE PROFILES AND VELOCITIES
DISCHARGE 5,000 CFS
RESERVOIR POOL EL 720
TAILWATER EL 518.33

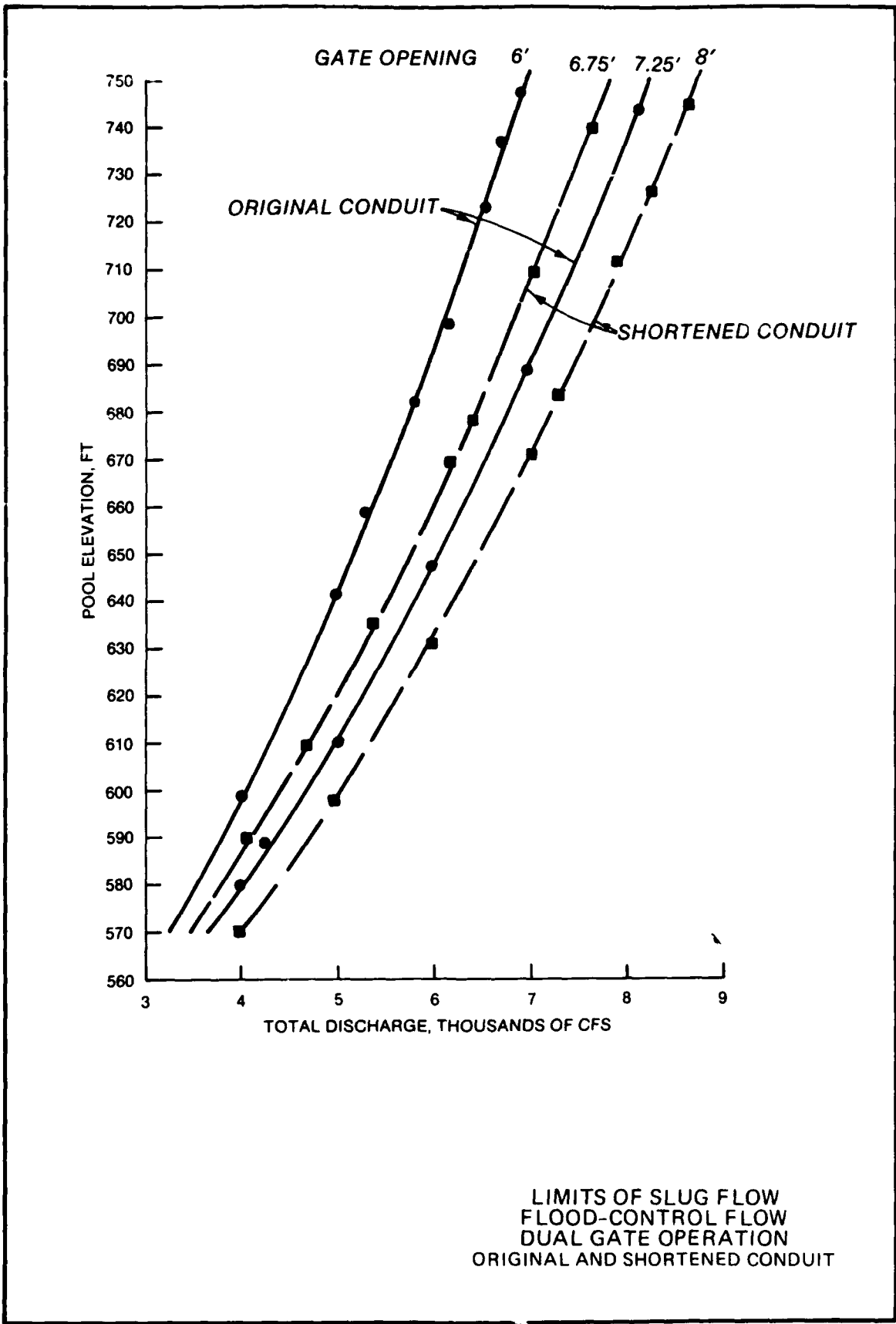
END SILL
STA 39+76.89

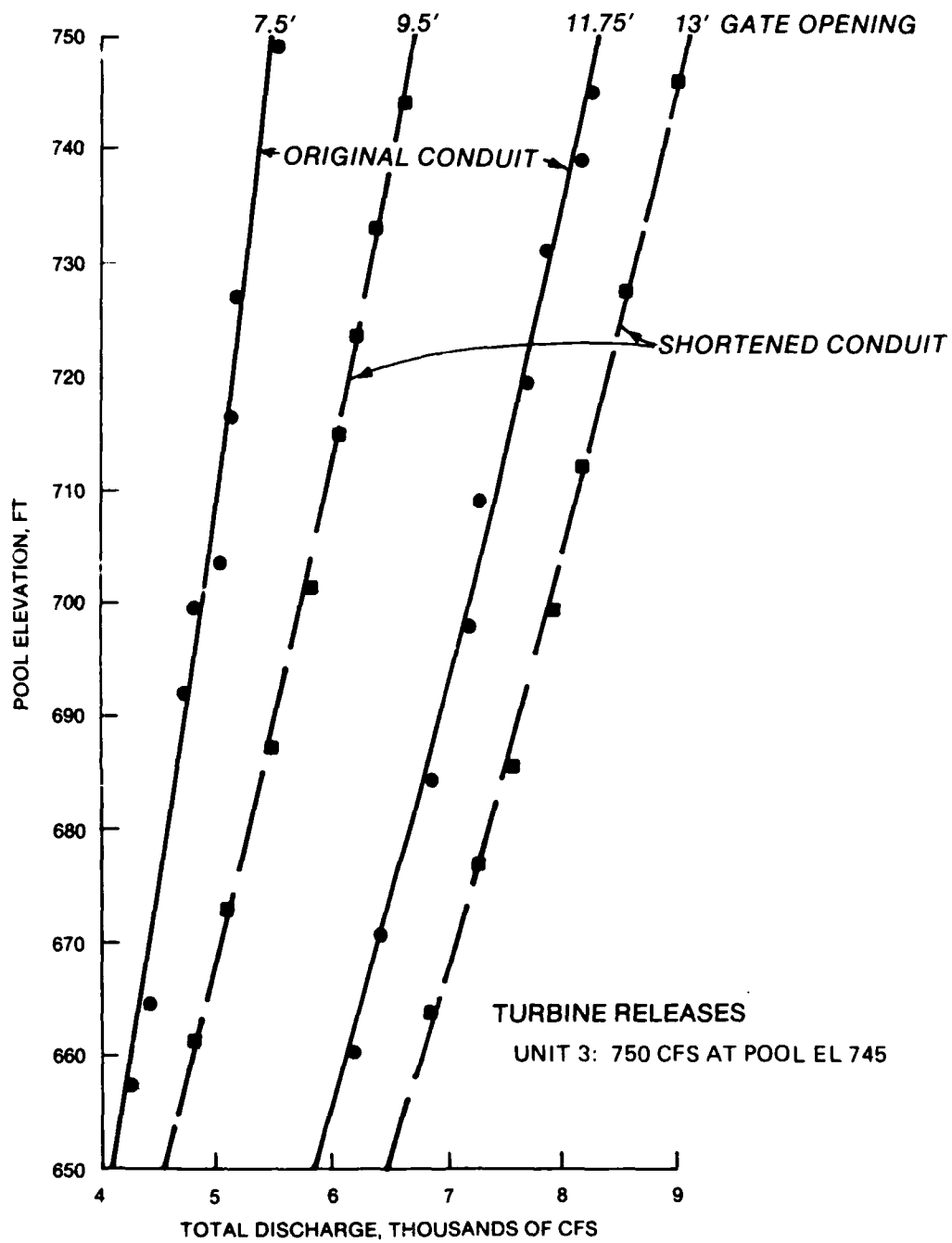


GENERAL PLAN AND PROFILE
 SHORTENED CONDUIT

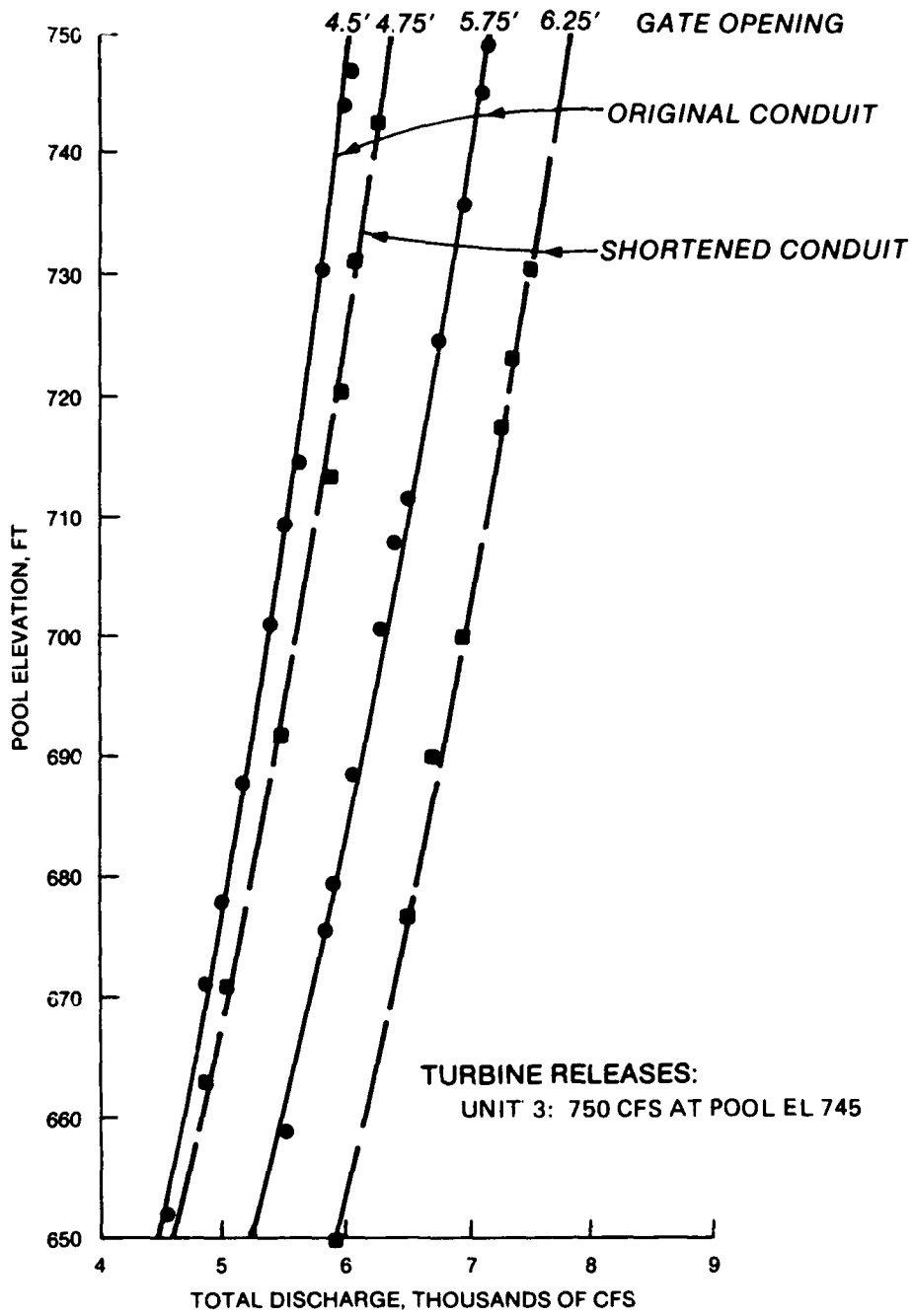


LIMITS OF SLUG FLOW
 FLOOD-CONTROL FLOW
 SINGLE GATE OPERATION
 ORIGINAL AND SHORTENED CONDUIT



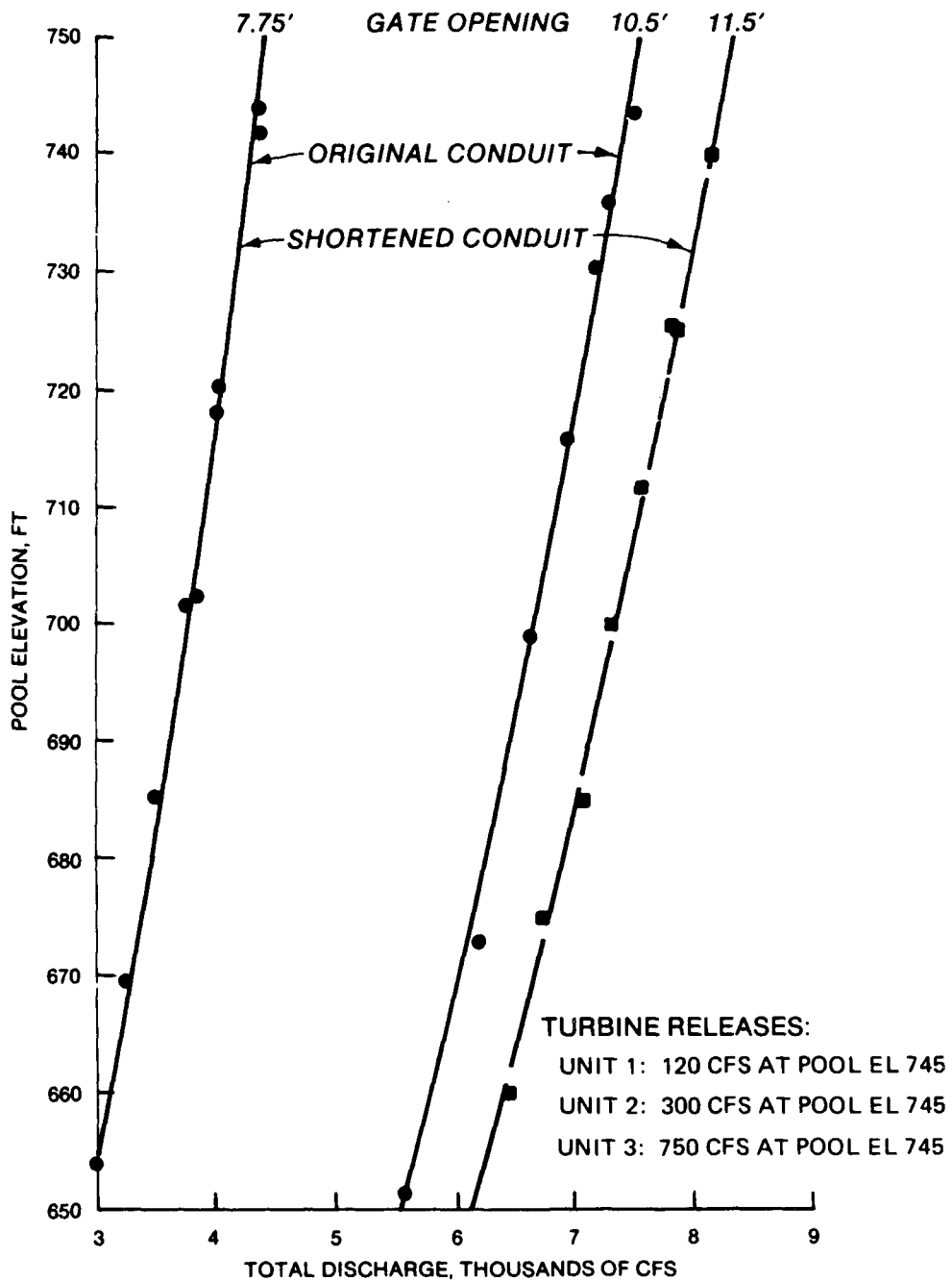


LIMITS OF SLUG FLOW
 COMBINED FLOOD-CONTROL AND
 TURBINE RELEASES
 FLOOD CONTROL WITH SINGLE GATE OPERATION
 ORIGINAL AND SHORTENED CONDUIT
 TURBINE UNIT 3

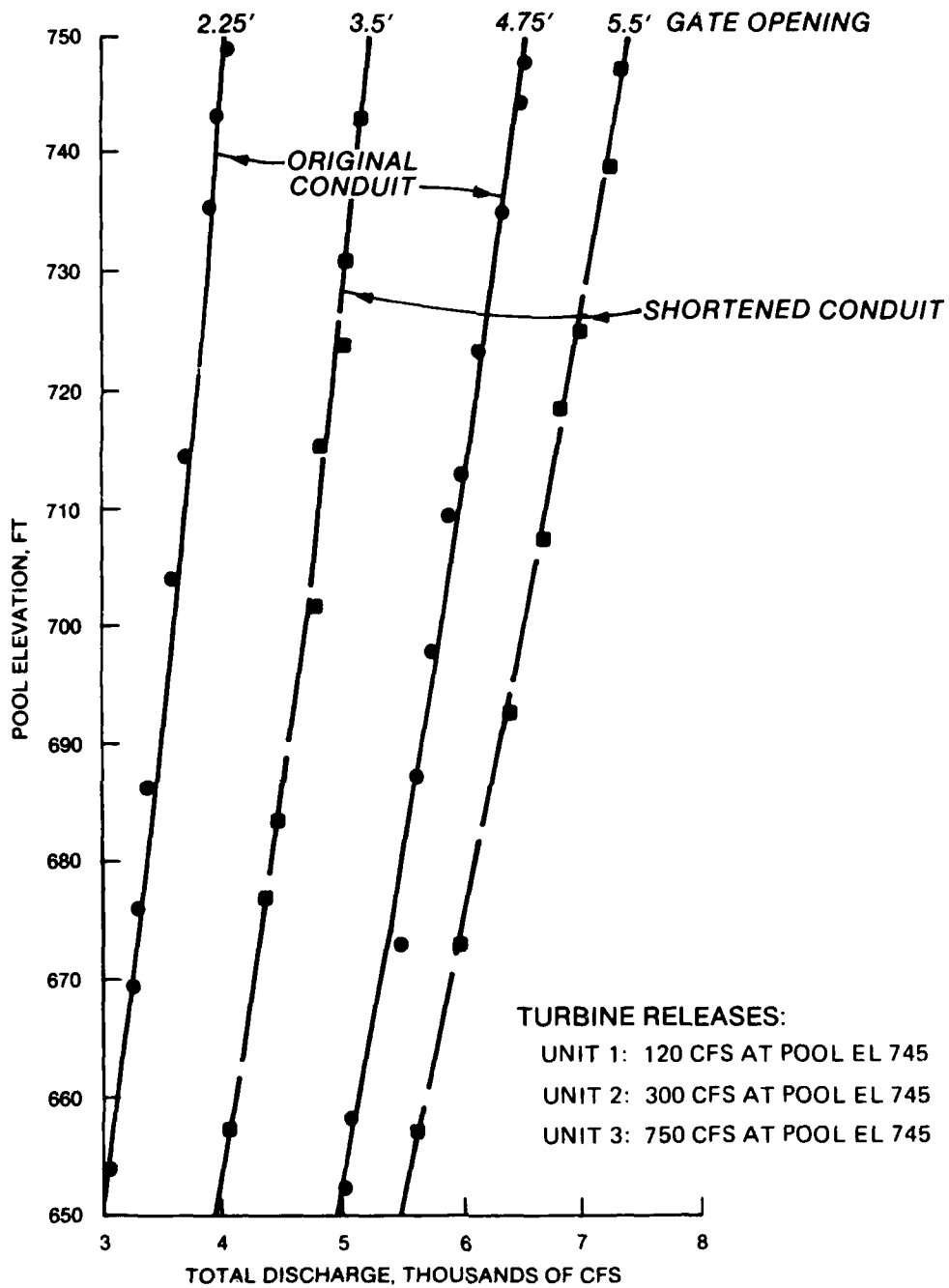


TURBINE RELEASES:
 UNIT 3: 750 CFS AT POOL EL 745

LIMITS OF SLUG FLOW
 COMBINED FLOOD-CONTROL AND
 TURBINE RELEASES
 FLOOD CONTROL WITH DUAL GATE OPERATION
 ORIGINAL AND SHORTENED CONDUIT
 TURBINE UNIT 3



LIMITS OF SLUG FLOW
 COMBINED FLOOD-CONTROL AND
 TURBINE RELEASES
 FLOOD CONTROL WITH
 SINGLE GATE OPERATION
 ORIGINAL AND SHORTENED CONDUIT
 TURBINE UNITS 1, 2, AND 3



TURBINE RELEASES:
 UNIT 1: 120 CFS AT POOL EL 745
 UNIT 2: 300 CFS AT POOL EL 745
 UNIT 3: 750 CFS AT POOL EL 745

LIMITS OF SLUG FLOW
 COMBINED FLOOD-CONTROL AND
 TURBINE RELEASES

FLOOD CONTROL WITH DUAL GATE OPERATION
 ORIGINAL AND SHORTENED CONDUIT
 TURBINE UNITS 1, 2, AND 3

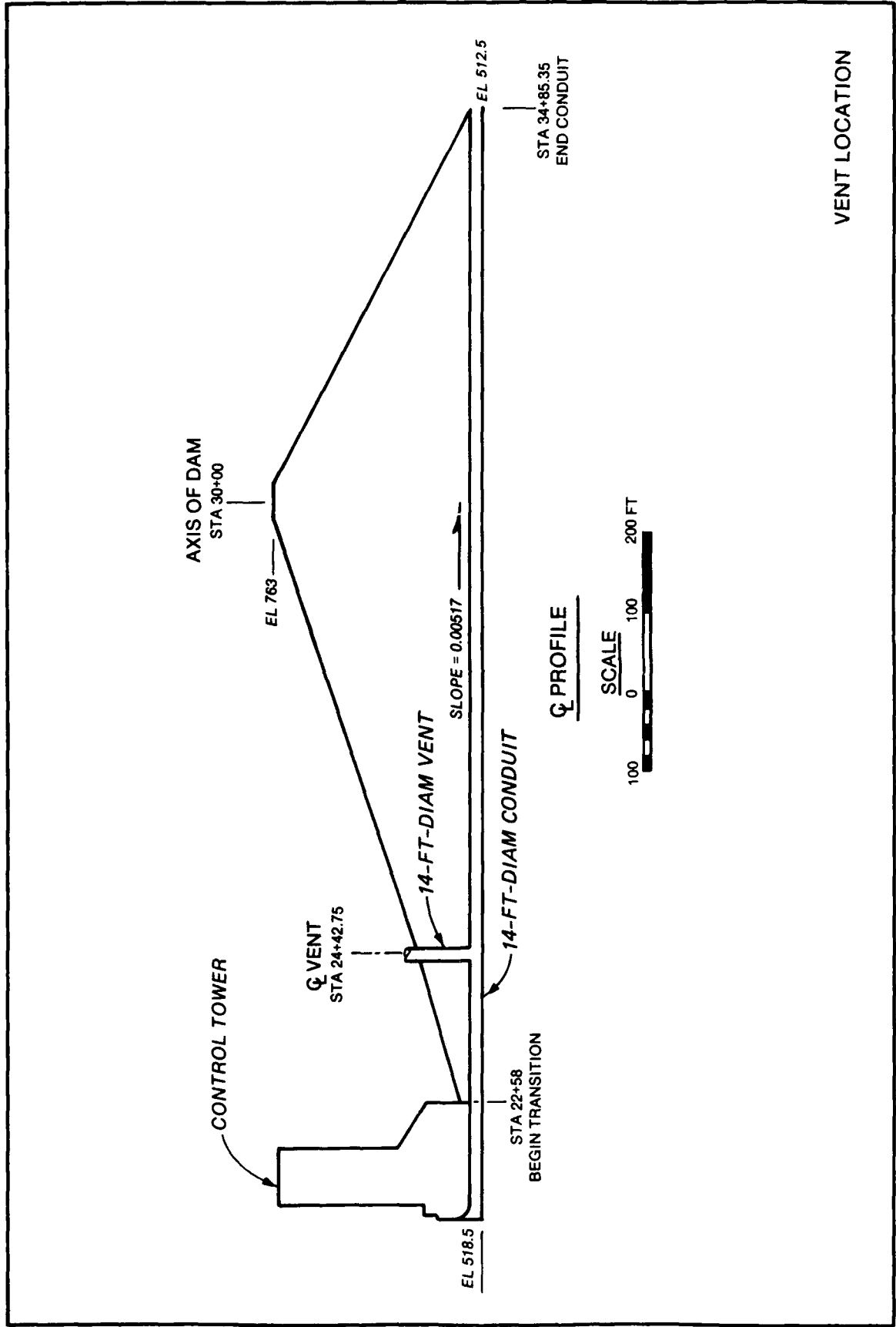
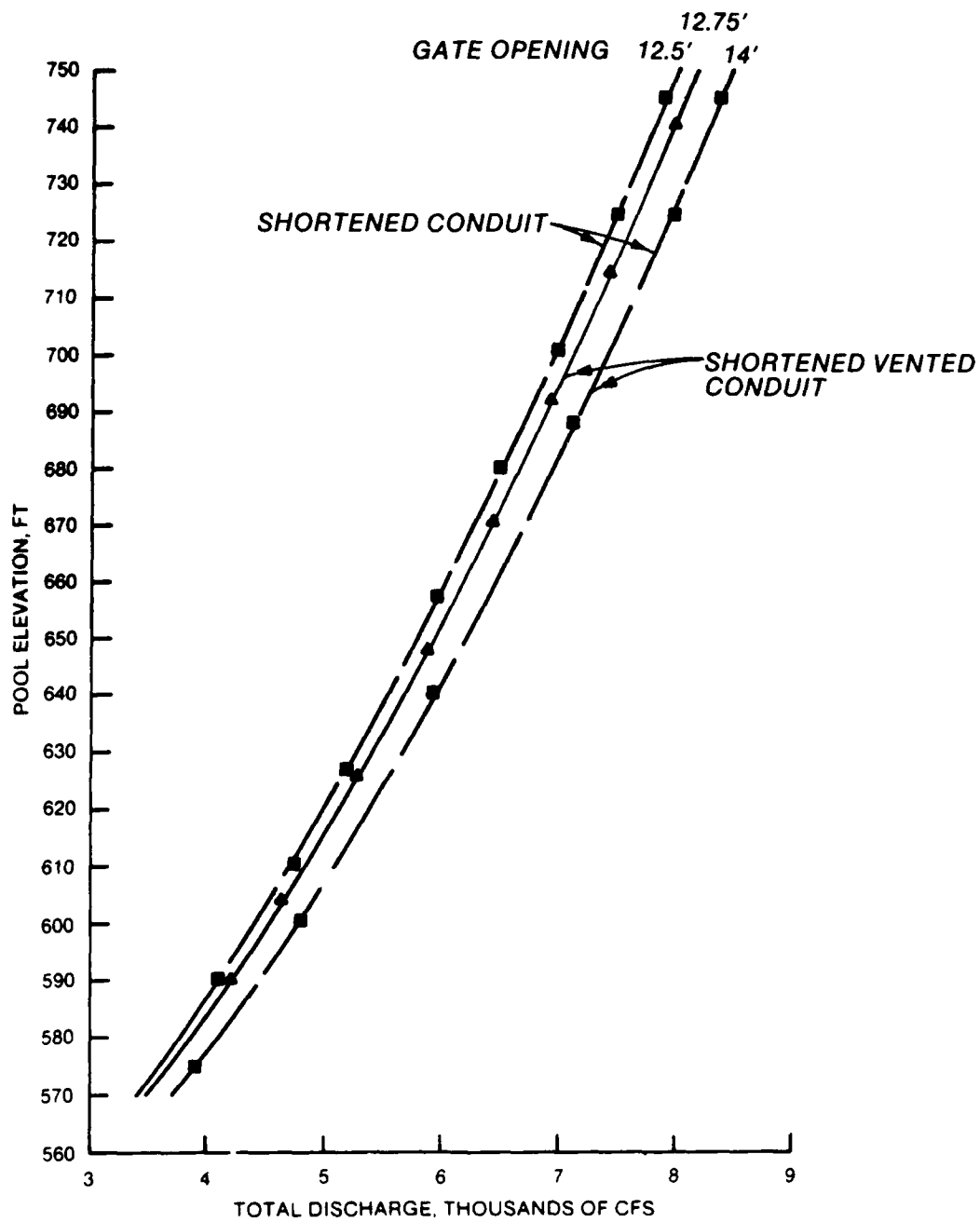
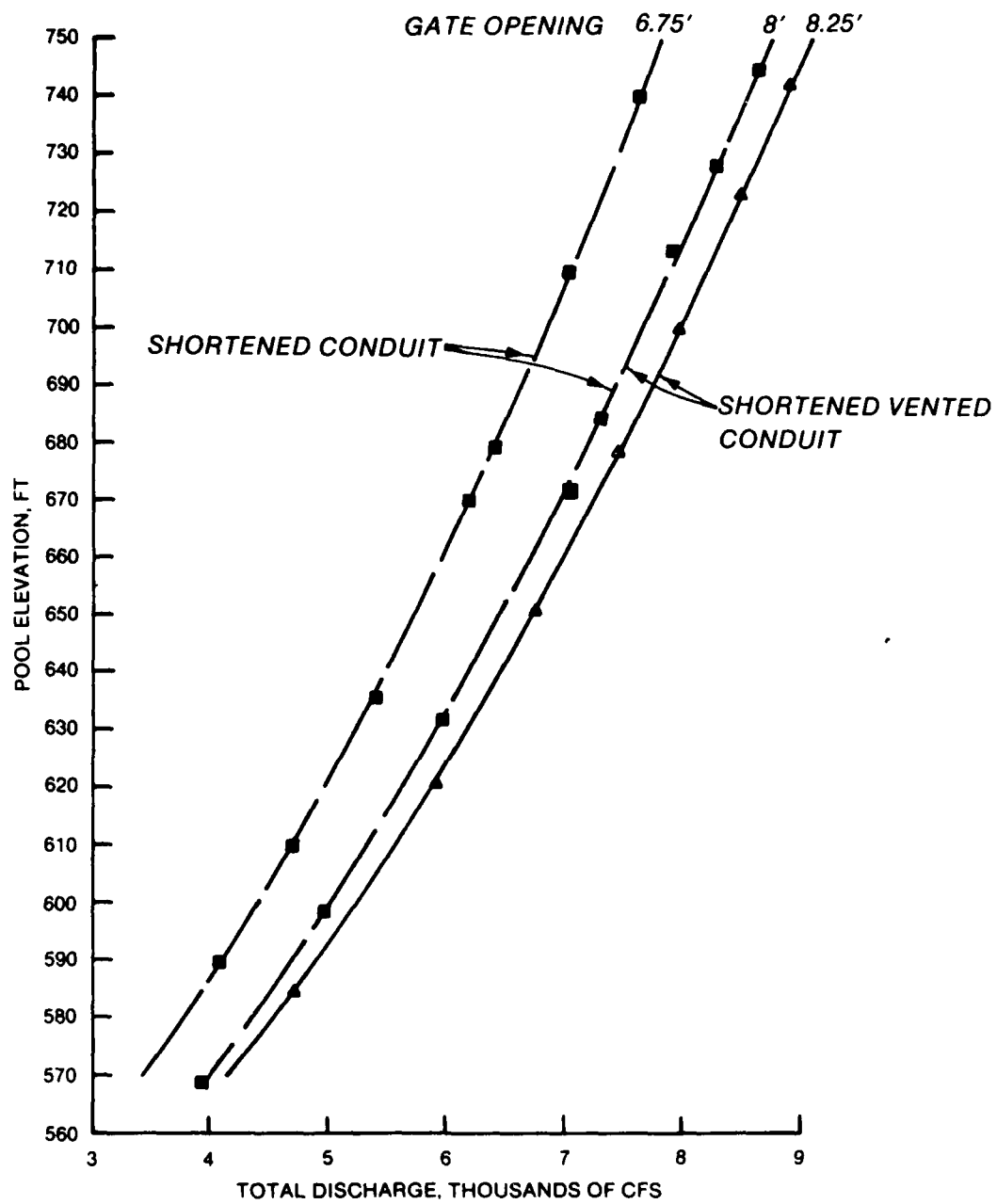


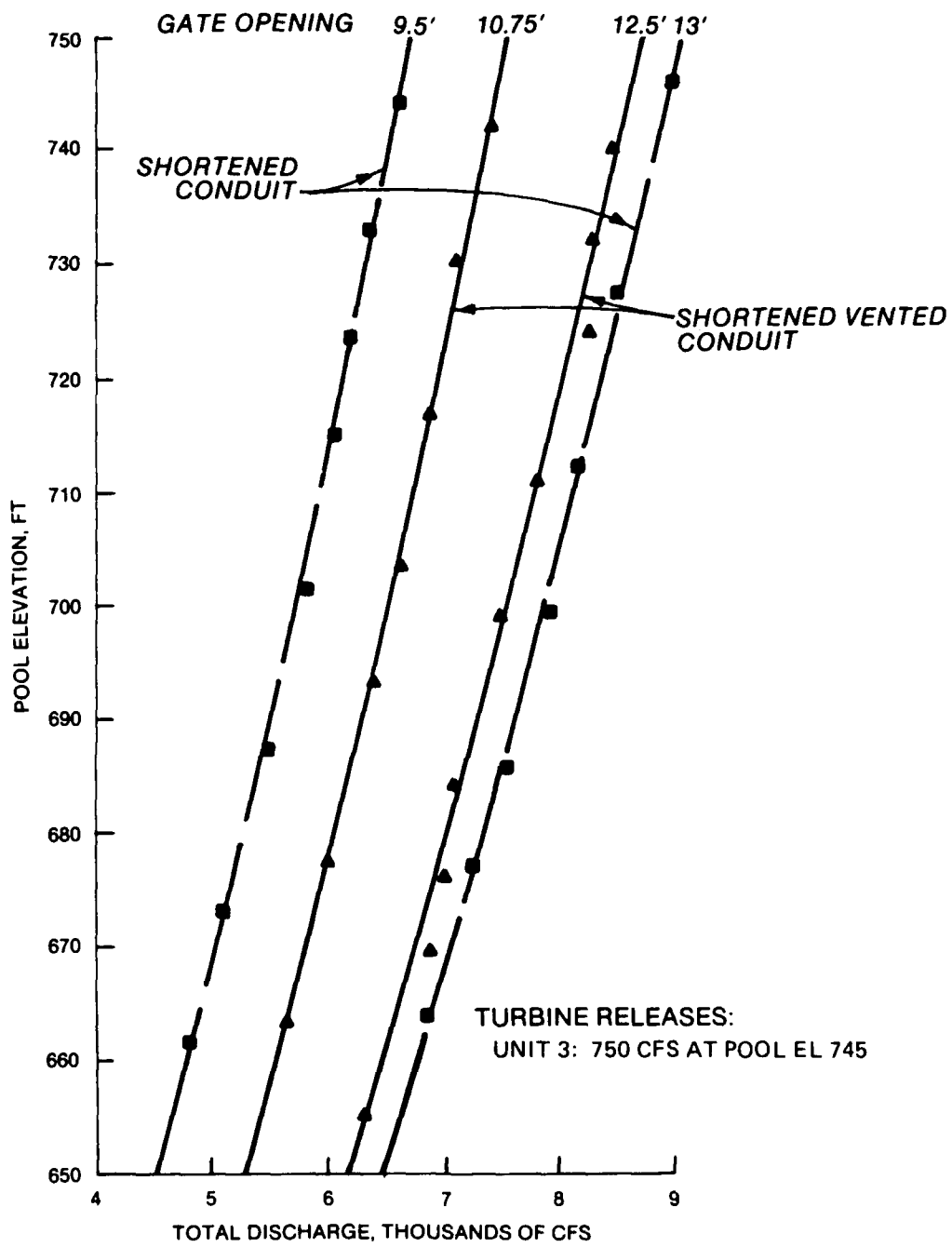
PLATE 24



LIMITS OF SLUG FLOW
 FLOOD-CONTROL FLOW
 SINGLE GATE OPERATION
 SHORTENED AND SHORTENED VENTED CONDUIT



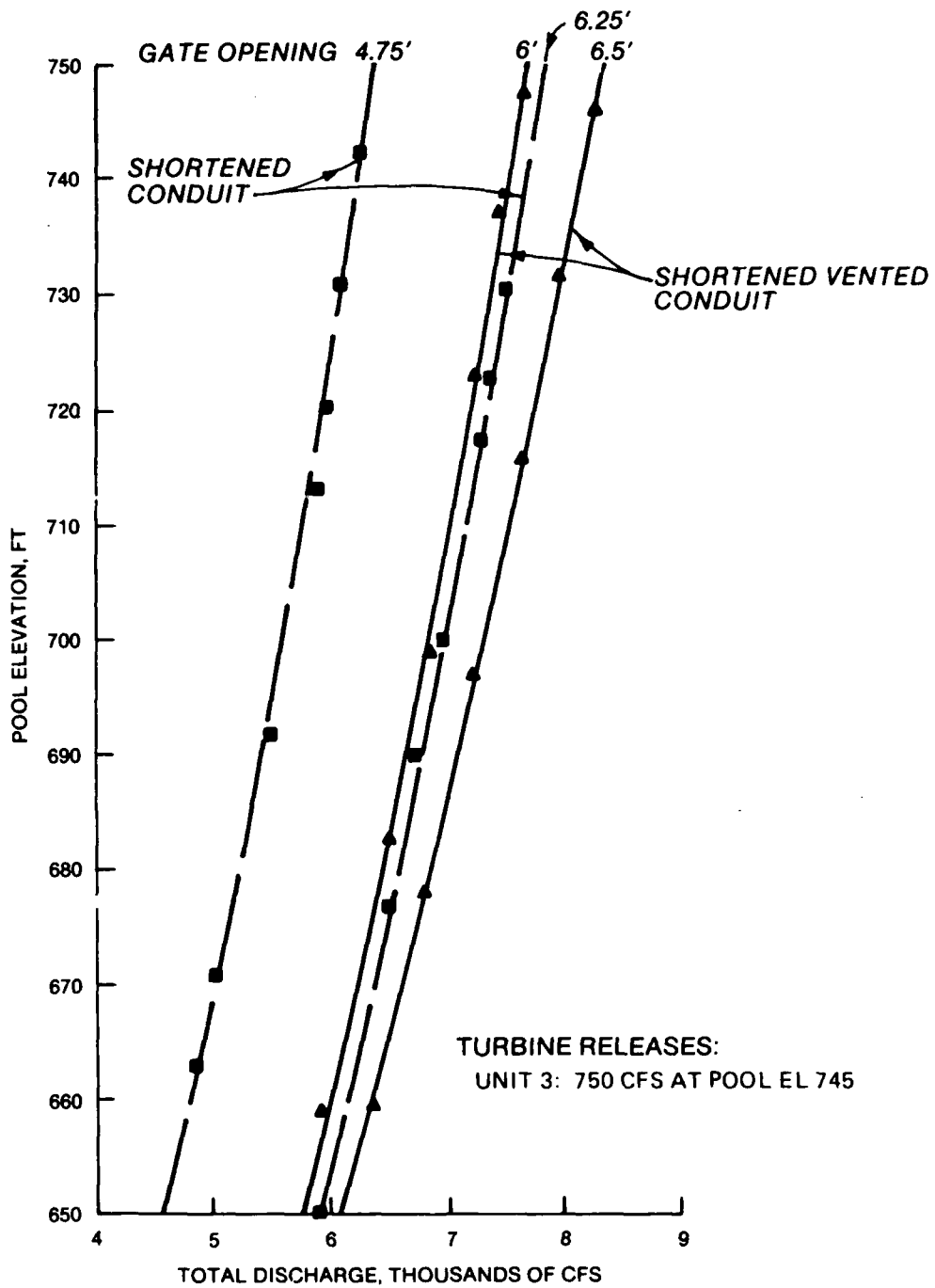
LIMITS OF SLUG FLOW
 FLOOD-CONTROL FLOW
 DUAL GATE OPERATION
 SHORTENED AND SHORTENED VENTED CONDUIT



TURBINE RELEASES:
UNIT 3: 750 CFS AT POOL EL 745

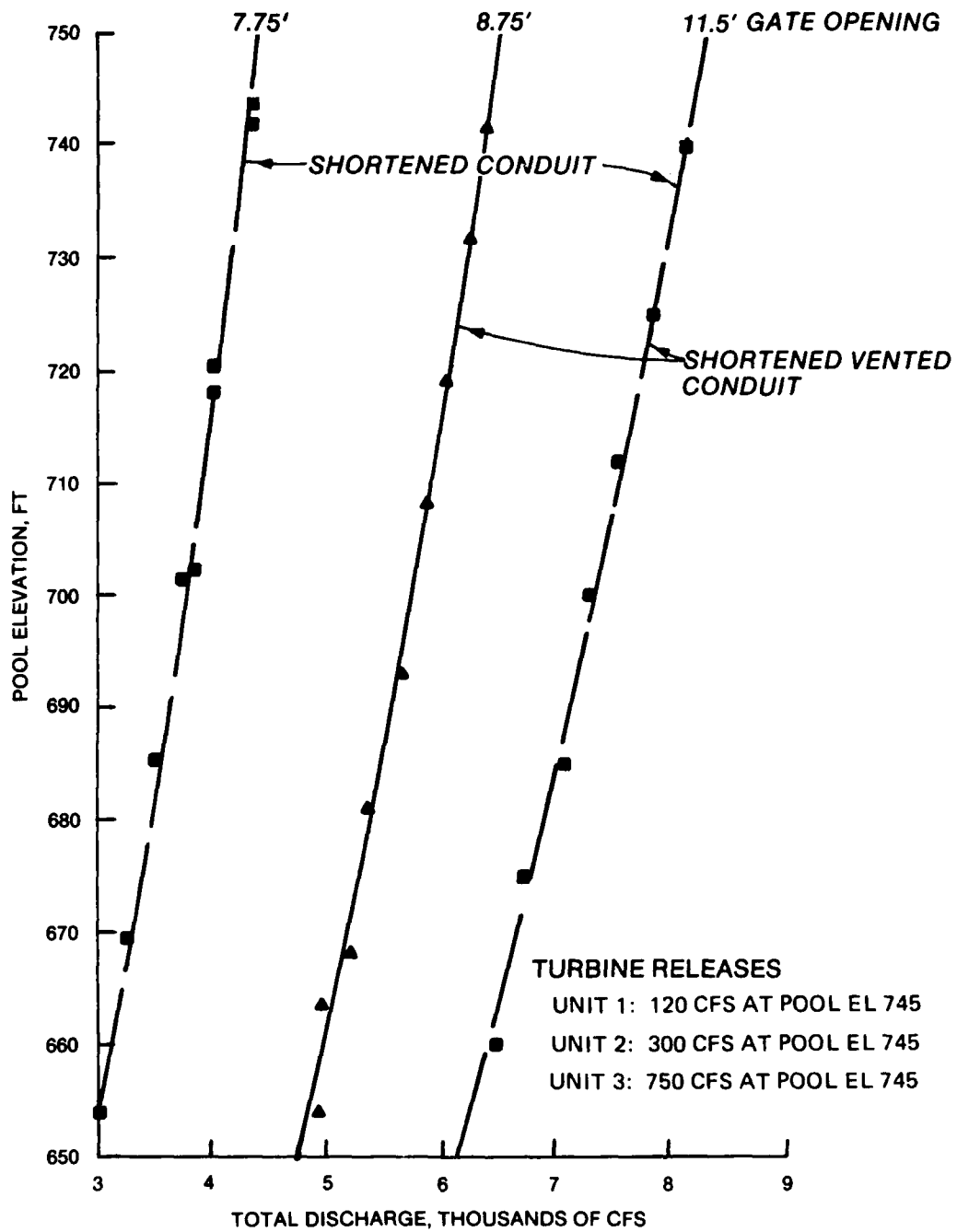
LIMITS OF SLUG FLOW
COMBINED FLOOD-CONTROL AND
TURBINE RELEASES

FLOOD CONTROL WITH SINGLE GATE OPERATION
SHORTENED AND SHORTENED VENTED CONDUIT
TURBINE UNIT 3



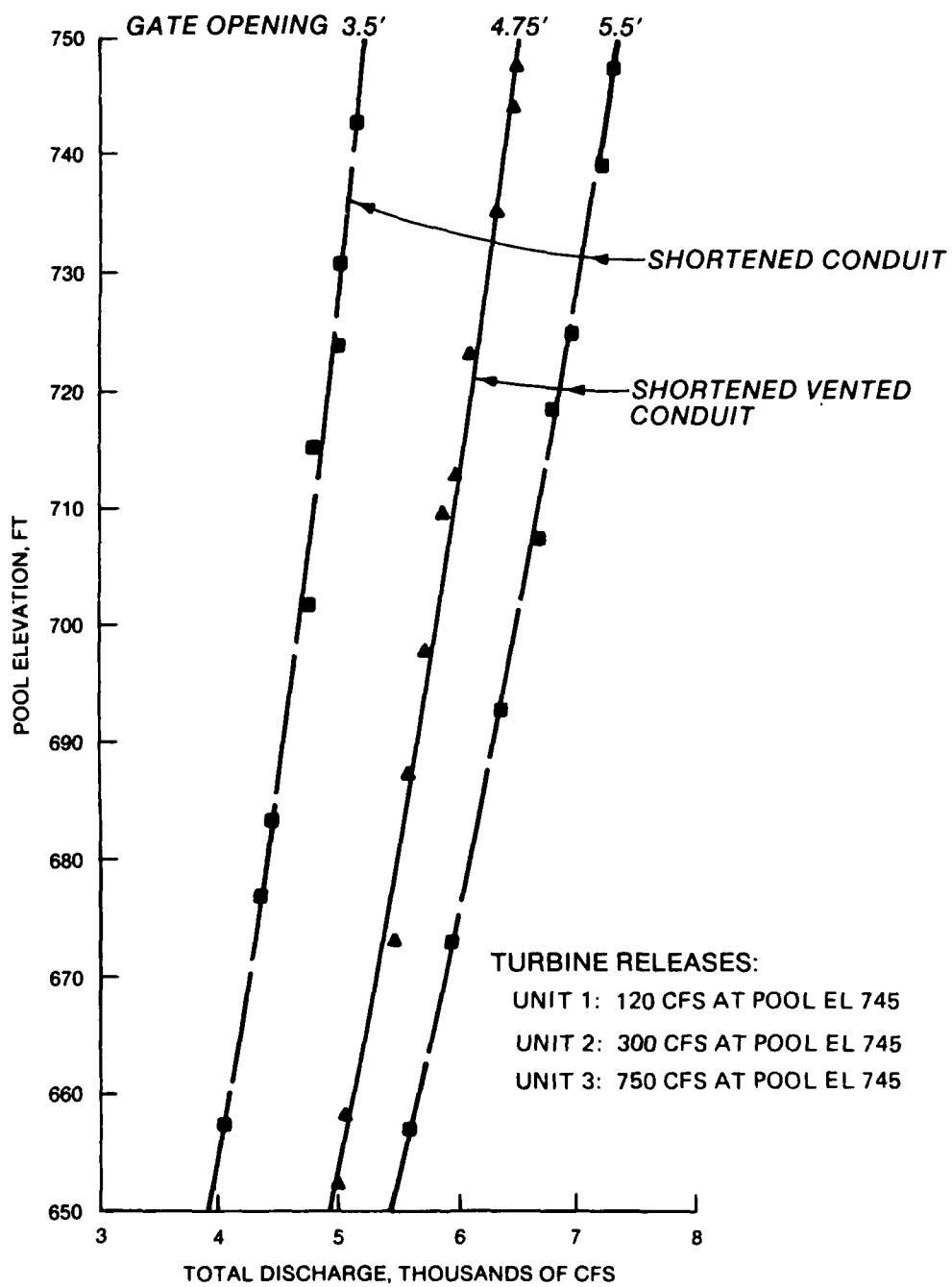
LIMITS OF SLUG FLOW
 COMBINED FLOOD-CONTROL AND
 TURBINE RELEASES

FLOOD CONTROL WITH DUAL GATE OPERATION
 SHORTENED AND SHORTENED VENTED CONDUIT
 TURBINE UNIT 3



LIMITS OF SLUG FLOW
 COMBINED FLOOD-CONTROL AND
 TURBINE RELEASES

FLOOD CONTROL WITH SINGLE GATE OPERATION
 SHORTENED AND SHORTENED VENTED CONDUIT
 TURBINE UNITS 1, 2, AND 3



LIMITS OF SLUG FLOW
 COMBINED FLOOD-CONTROL AND
 TURBINE RELEASES

FLOOD CONTROL WITH DUAL GATE OPERATION
 SHORTENED AND SHORTENED VENTED CONDUIT
 TURBINE UNITS 1, 2, AND 3